

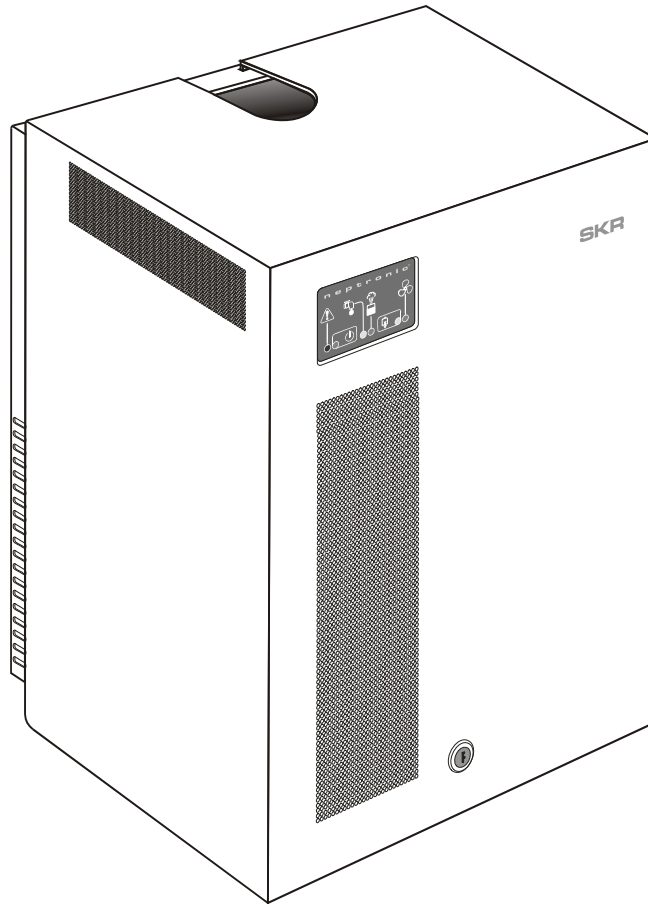

neptronic®

SKR series ***Steam Humidifier – Kit N*** (Patent Pending)



Installation instructions
& user manual
READ AND SAVE THESE INSTRUCTIONS

SKR-N – ENG/111012



Foreword

- A. These installation instructions and operation manual have been developed to facilitate the installation and the operation of the **SKR** series steam humidifier. The strict application of these instructions will ensure the conformity of your installation and operation as per manufacturer's recommendations.
- B. The application of these instructions is one of the conditions for the application of the warranty.
- C. The application of these instructions does not ensure at any time conformity to procedures, regulation or local codes, regarding electrical installation and connection to local water supply.
- D. This product has been declared to conform to applicable Canadian and American safety standards and directives and bear the CSA (c) & (us) mark. The certificate of conformity CSA is available upon request to the manufacturer.
- E. © 2011: All right reserved, this document cannot be reproduced totally or partially by any means whether, electronic, mechanical, photocopy, recording or other, without prior written authorization of National Environmental Products Ltd.

Manufacturer Presentation

National Environmental Products Ltd. (NEP) is the owner of the Neptronic® brand.
NEP develops, manufactures and services a complete line of:

- Steam humidifiers,
- Humidistat among the most precise and the most reliable on the market,
- Actuators to regulate air damper or valves,
- Electric heaters,
- Thermostats and other control peripherals used to control HVAC equipment.

For more information about our products, visit our web site at www.neptronic.com

Each Neptronic® product benefits from over 35 years of experience of our qualified staff.

From the inspiration to realization, innovation has been the standard in design. As the result of this dedication, NEP Ltd. owns several patents, notably the ENERDRIVE system and the AFEC system.

Manufacturing is conducted on the premises of our modern 80,000 sq.ft. (8 000m²) facility in Montreal, Canada.

Our quality system is built on the ISO 9001 model.

Our vision "**A Customer for Life**" is realized by listening our customers' needs and by supplying them with products, which exceed their expectations in quality, functionality and durability.

National Environmental Products Ltd.

Tel. (Toll free in North America): 1 800 361-2308

Tel.: (1) (514) 333-1433

Fax: (1) (514) 333-3163

Fax Customer service: (514) 333-1091

Business hours: Monday to Friday, 8:00am to 5:00pm (Eastern time)



Table of contents

Foreword & Manufacturer Presentation.....i

1. Presentation.....2

 1.1. Description of accessories supplied with the humidifier.....2

 1.2. Humidifier overview2

 1.3. Numbering system.....2

2. Definition.....3

 2.1. Evaporation chamber3

3. Characteristics3

4. Mechanical installation.....4

 4.1. General recommendations4

 4.2. Positioning.....4

 4.3. Wall mounting.....4

5. Steam output connection5

 5.1. Typical installation5

 5.2. General recommendations5

 5.3. Recommendations for steam distribution piping6

 5.4. Recommendations for the location of the steam dispersion tube6

6. Plumbing connections.....7

 6.1. Water supply.....7

 6.2. Drain connections.....8

7. Power supply connections9

8. Control diagrams10

 8.1. ON/OFF Humidifier (standard)10

 8.2. Modulating Humidifier11

9. Control panel display12

10. Description of the control PC Board.....13

 10.1. P.C. Board for ON/OFF Humidifier (standard).....13

 10.2. P.C. Board for Modulating Humidifier14

11. Start up procedure15

12. Description of operation of the SKR.....15

13. Shut-down procedure.....16

14. Maintenance.....16

 14.1. General16

 14.2. Evaporation chamber cleaning16

15. Exploded View and Bill of Material.....18

 15.1. Exploded view18

 15.2. Bill of Material18

16. Types of alarm19

17. Troubleshooting guide.....20

18. Electrical diagram.....21

 18.1. ON/OFF Humidifier (standard).....21

 18.2. Modulating Humidifier22

 18.3. Modulating humidifier with HRO2023

 18.4. Modulating humidifier with HRO20 and SHR10 or SHC80.....23

General condition of sales & warranty.....24



1. Presentation

Thank you for choosing a Neptronic® product. You have purchased the best and the most robust humidifier in its category

1.1. Description of accessories supplied with the humidifier

- 1 steam dispersion tube.
- 1 length of flexible steam hose.
- 2 adjustable collars to attach the steam hose to the steam outlet.
- 1 female fitting and a braided hose to connect the water supply.
- For **modulating humidifier** only: 1 resistor 500 Ohms.

1.2. Humidifier overview

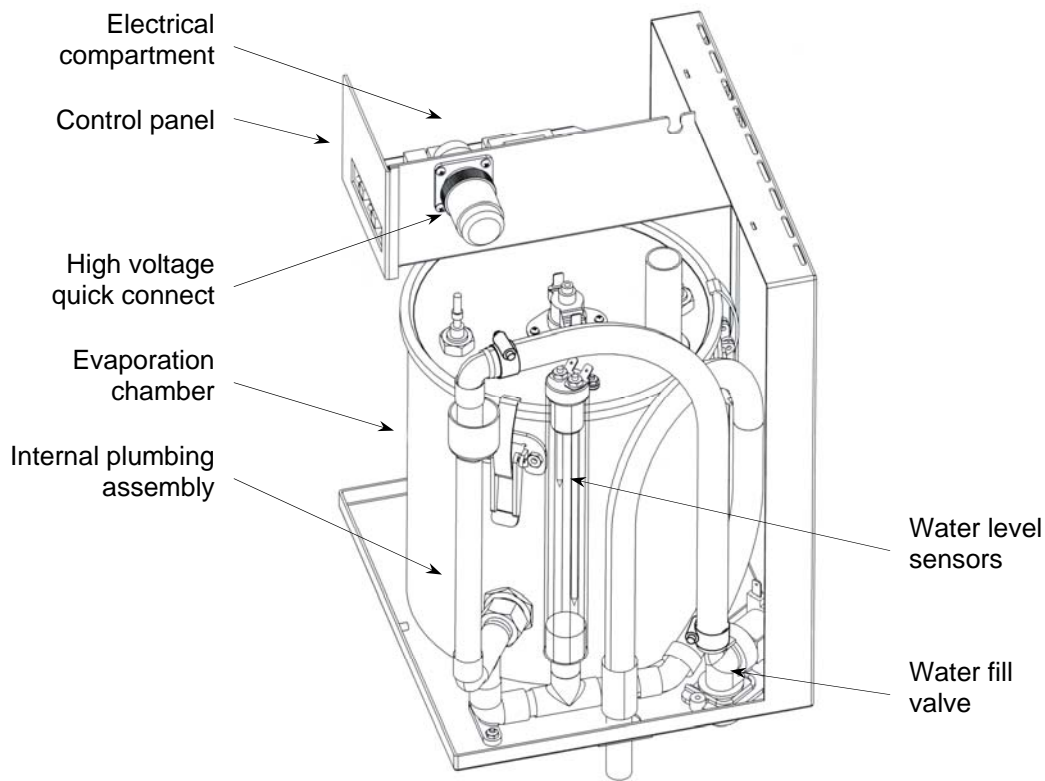

(Fig. 1)

1.3. Numbering system

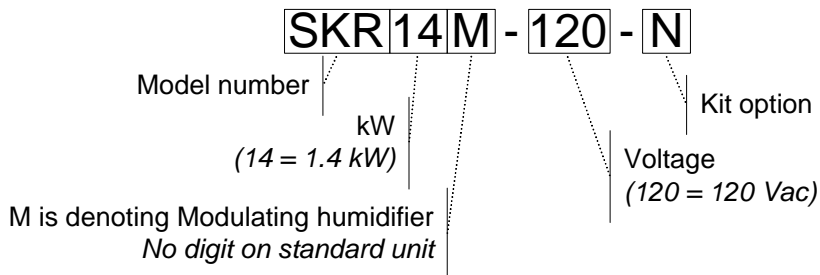



2. Definition

2.1. Evaporation chamber

Assembly including the stainless steel cylinder and a cover equipped with an electric element.

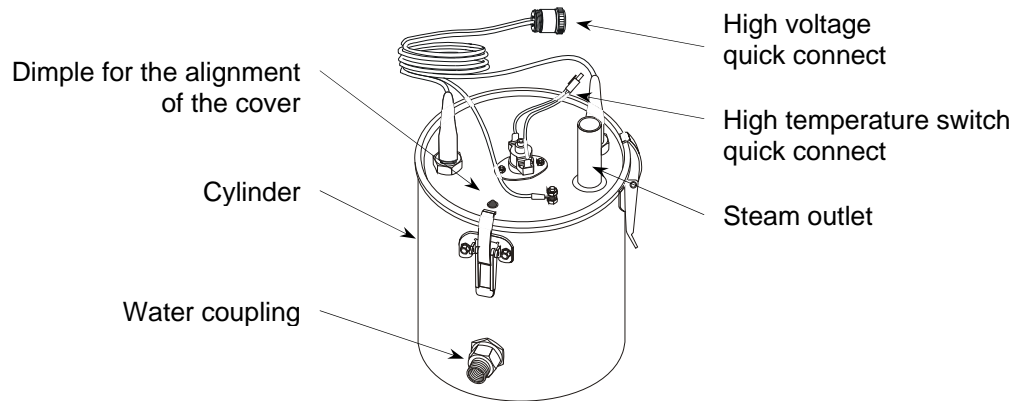

(Fig. 2)

3. Characteristics

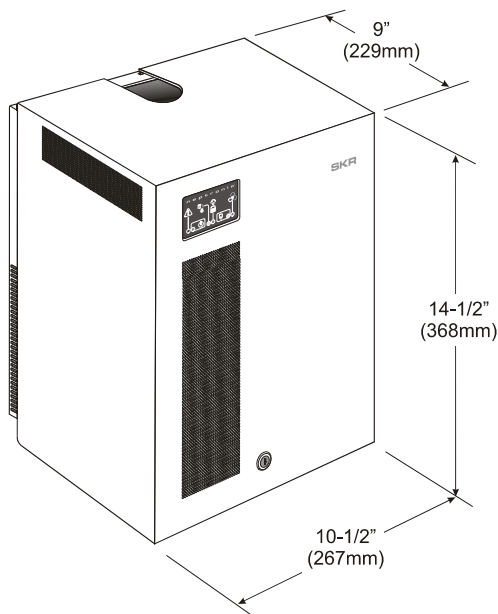

(Fig. 3)

Model	Capacity Lb/hr (kg/hr)	Electrical Requirements			Steam outlet diameter in (mm)	Weight lb (kg)	
		Voltage (V)	Current (A)	Power (KW)		Empty	With water
SKR-14 <i>CASA</i>	4.5 (2.05)	120	12	1.4	7/8" (22)	22 (10)	35 (16)
SKR-25 <i>VILLA</i>	7.5 (3.41)	240	11	2.5	7/8" (22)	22 (10)	35 (16)
SKR-30 <i>CHATEAU</i>	9 (4.1)	240	13	3.0	1-3/8" (35)	22 (10)	35 (16)
SKR-40 <i>BELVEDERE</i>	12 (5.45)	240	17	4.0	1-3/8" (35)	22 (10)	35 (16)



4. Mechanical installation

4.1. General recommendations

- **CAUTION: RISK OF ELECTRIC SHOCK. DISCONNECT THE HUMIDIFIER FROM THE ELECTRIC SUPPLY BEFORE PROCEEDING TO THE MECHANICAL INSTALLATION.**
- **IMPORTANT:** Mechanical installation should conform to Local and National Codes.
- Location: Plan a location which is easy to access in order to permit a proper inspection and servicing of the humidifier.
Do not install humidifier where failure of the appliance could cause damage to the building structure or to costly equipment.
This location should be well ventilated; the ambient temperature should not exceed 85°F (30°C).
- The maximum distance between the humidifier and the steam dispersion tube in the ventilation duct should not exceed 6 feet (1.8m) (maximum length of the steam hose).

4.2. Positioning

- The front panel and the left side (electrical compartment) should be accessible in order to permit easy servicing of the humidifier. Leave a clearance of 36" (0.91m) from the front panel, 12" (0,30m) from the left side, 6" (0.15m) from the right side and 8" (0.20m) above the humidifier.
- The **SKR** humidifier should be mounted 39" to 47po (1 to 1,2m) above floor for the installation of water supply, drain piping and electrical connections.

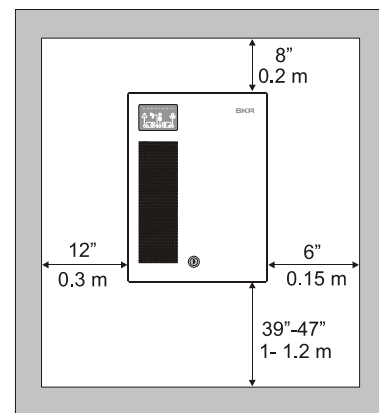

(Fig. 4)

4.3. Wall mounting

- **IMPORTANT:**
 1. Risk of malfunction. The humidifier must be level.
 2. Risk of overheating. Do not block the ventilation openings located on the top, front, sides and rear of the cabinet.
- Check the solidity of the chosen support or wall (bricks, concrete, stud partition wall, etc) on which the humidifier will be mounted (see page 3 for the weight of the unit).
- Use the keyholes located on the back panel of the humidifier.
- Drill holes for the upper anchors (holes with eyelets) into the support or wall as per dimensions specified in the table (fig.5). The hole dimensions (diameter and depth) should be in accordance with the recommendations of the chosen anchors.
- If necessary, install bolt anchors.
- Insert the 2 screws (holes with eyelet) of a minimum diameter of 1/4" (6mm) (screws are not supplied).
Leave a clearance between screw heads and wall in order to permit the mounting of the humidifier.
- Hang the humidifier on the 2 screws.
- When the humidifier is positioned on the screws, tighten the screws to secure the humidifier.

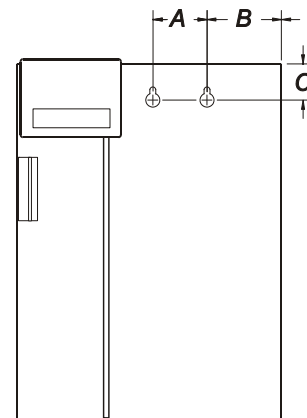

(Fig. 5)
Front view

Model	Dimensions (mm)		
	A	B	C
SKR	2" (51)	3.06" (78)	1.44" (37)



5. Steam output connection

5.1. Typical installation

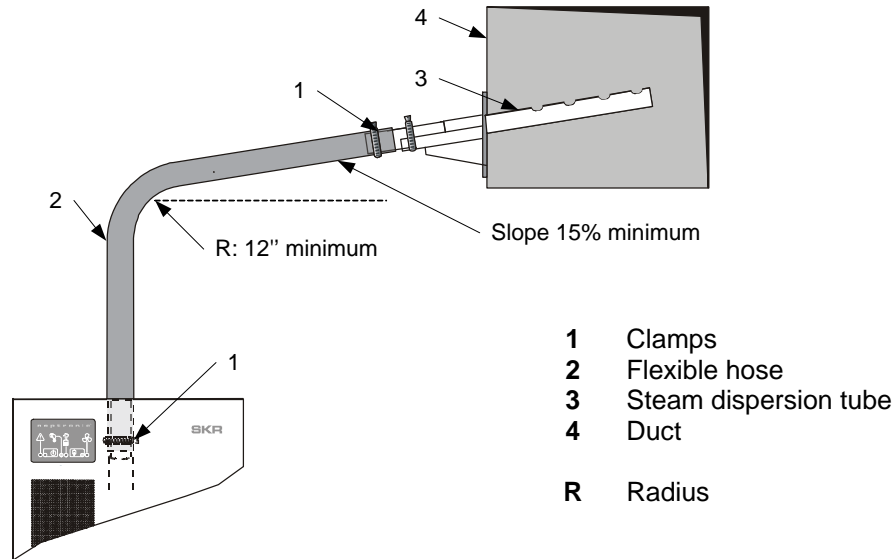

(Fig. 6)

5.2. General recommendations

Follow these general installation rules in order to avoid any condensation accumulation which can cause severe water accumulation in the duct or a humidifier malfunction.

IMPORTANT: Risk of malfunction. Avoid kinks, sags and areas where condensate can become trapped.

- a) **The slope of the steam hose (rigid or flexible) should not be less than 15%** (7 horizontal lengths for 1 vertical length) in order to ensure continuous drainage of condensation back to humidifier or to a steam trap.
- b) **The lowest point of any steam hose or rigid pipe must be the humidifier (fig.7b).** If the humidifier cannot be the lowest point of the piping, install a steam trap(s) (S Type) at the lowest point(s) of the steam supply piping (fig.7c). This trap should have a minimum height of 3" (76mm).
- c) **Total length of the steam hose or rigid pipe should not exceed 6 feet (1,8 meters).** Longer runs will result in added condensation losses and may result in system malfunction. Minimum radius of any change of direction should be 12" (307mm). A maximum of 2 long radius elbows (12") are to be used on the steam distribution line.
- d) Whenever using rigid copper pipe, use insulation to diminish condensate build up.

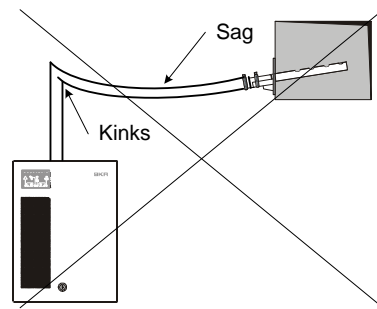

(Fig. 7a)

Incorrect installation

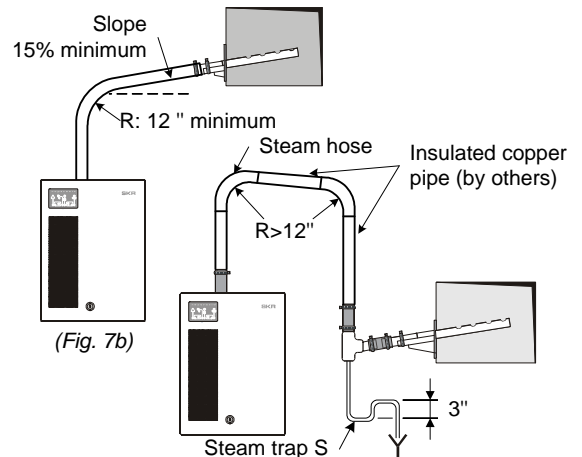

(Fig. 7b)

(Fig. 7c)

Correct installations



5.3. Recommendations for steam distribution piping

Model	Steam outlet		Steam dispersion tube	MAXIMUM allowable duct static pressure at dispersion tube location in. water (Pa)
	Qty	Diameter in (mm)	Length in (mm)	
SKR-14 / 25	1	7/8" (22)	9" (229)	0.5" (125)
SKR-30 / 40	1	1-3/8" (35)	14" (356)	0.5" (125)

IMPORTANT: RISK OF MALFUNCTION. THE STATIC PRESSURE AT THE DISPERSION TUBE LOCATION SHOULD NOT BE GREATER THAN 0.5" (125 Pa) DURING OPERATION. FAILURE TO DO SO WILL VOID THE WARRANTY.

For a higher static pressure, use the Neptronic® SK300 commercial series humidifier.

5.4. Recommendations for the location of the steam dispersion tube

- **IMPORTANT: Risk of malfunction.**
 1. Do not split the steam output piping to supply more than one duct.
 2. Do not reduce the diameter of the steam hose or piping. Hose and piping diameter must be the same as the diameter of the humidifier steam outlet.
- Provide a **minimum of 18" (460mm) of straight duct**, without obstructions or elbows, downstream of the dispersion tube.
- Select an accessible location in the supply air duct.
- For the **SKR-14 & 25**, use a template and drill a 1-1/2" (38mm) hole in the supply air duct for the installation of the of 7/8" diameter dispersion tube.
- For the **SKR-30 & 40**, use a template and drill a 2" (51mm) hole of in the supply air duct for the installation of the of 1-3/8" diameter dispersion tube.
- Secure the dispersion tube bracket to the duct using sheet metal screws (not included).
- In a vertical duct installation the holes of the dispersion pipe should be aligned with the air flow (see fig. 8d & 8e below).

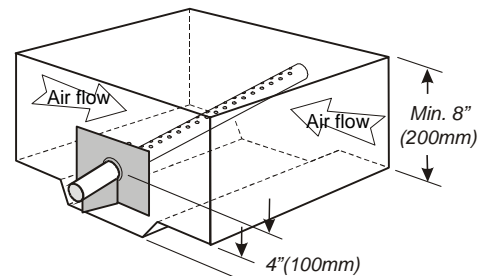

(Fig. 8a)
Horizontal duct with a minimum height of 8" (200mm)

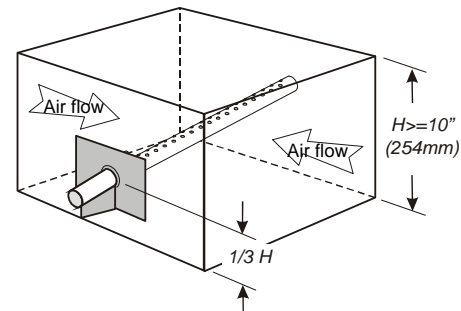

(Fig. 8b)
Horizontal duct with a minimum height of 10" (254mm)

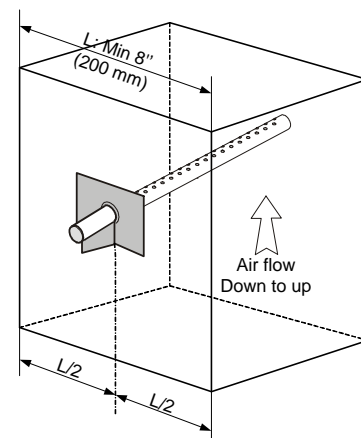

(Fig. 8c)
Mounting of the dispersion tube in a vertical duct

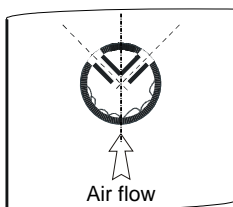

(Fig. 8d)
Alignment of dispersion pipe in a vertical duct for the SKR-14/25

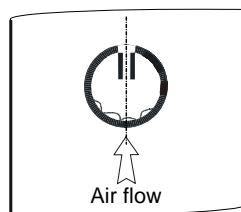

(Fig. 8e)
Alignment of dispersion pipe in a vertical duct for the SKR-30/40



6. Plumbing connections

The **SKR** humidifier can operate with soft or hard water. Therefore, for normal operation, no pre-treatment of water is necessary.

IMPORTANT: Plumbing installation should conform to Local and National Codes.

6.1. Water supply

- Water inlet specifications:
 - ✓ **IMPORTANT: Risk of malfunction, do not use demineralized water.**
 - ✓ Inlet water pressure: 15 to 70 psig (1 to 4,8 bars)
IMPORTANT: Risk of malfunction. Do not reduce water supply flow.
 - ✓ Maximum temperature: 85°F (30°C)
 - ✓ 3/8" (10mm) standard copper supply water connection
- To facilitate servicing, a shut off valve (not supplied) should be installed in the water supply line, close to the humidifier.
- It is recommended to install a standard strainer in the water supply line.
- If required, an air chamber made of copper pipe (see fig. 9) will absorb hydraulic shock, avoiding water hammer, when the fill valve closes. There are other standard types of air chambers commercially available.

Please follow the steps below:

- Connect 3/8" (10mm) copper pipe to the 3/8" (10mm) braided hose (supplied).
- Hand tighten the swivel top 3/4" (20mm) fitting to the male threaded valve connection.
IMPORTANT: Risk of damage to the valve, do not use wrench to tighten swivel.

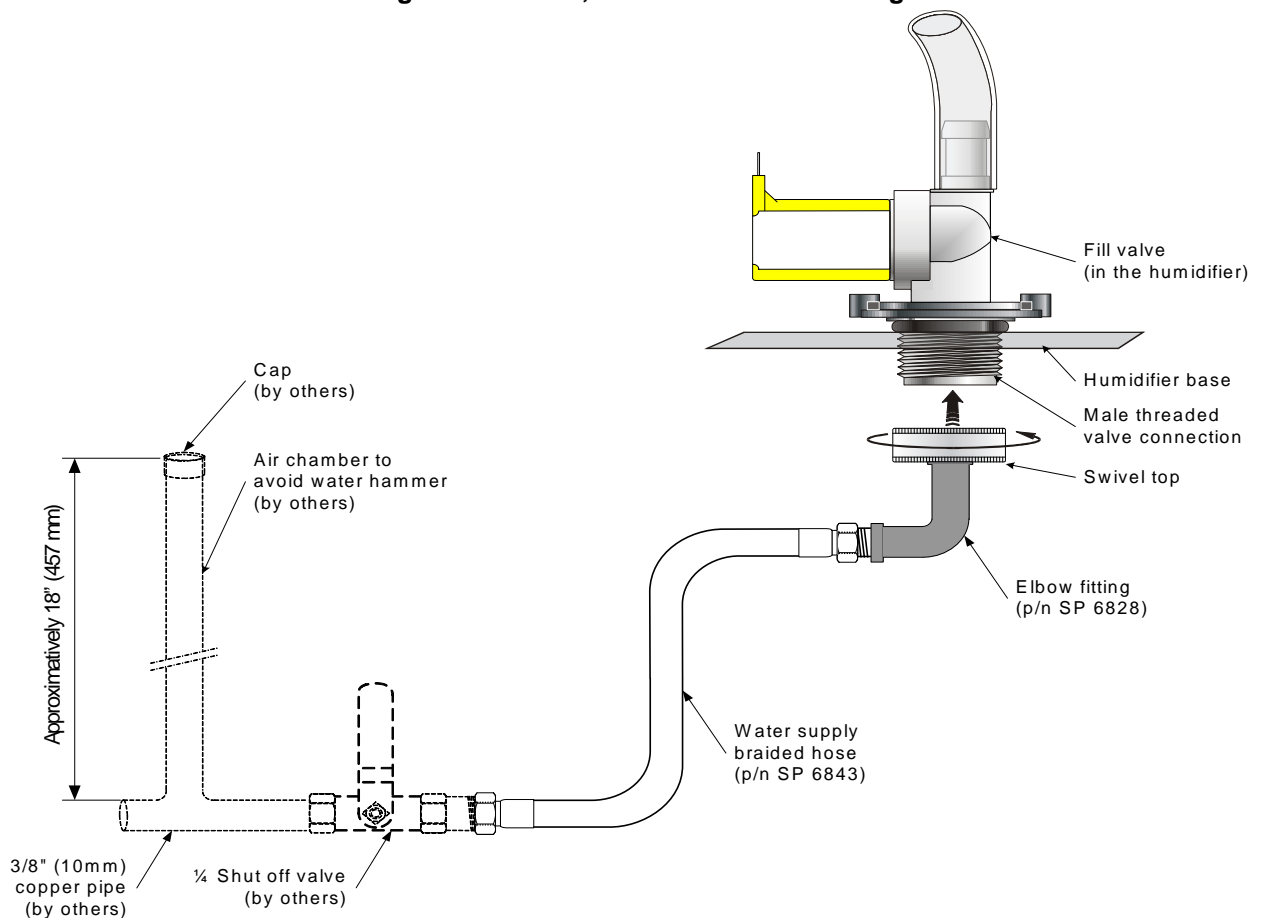

(Fig. 9)



6.2. Drain connections

- **IMPORTANT: No external drain traps are required.**
- Drain outlet specification:
 - ✓ Main drain 1/2" (13mm) standard copper (evaporation chamber).
 - ✓ Pan drain 1/2" (13mm) standard copper.
 - ✓ Water drain temperature: 140°F (60°C).
- **Two pipes minimum 1" (25mm)** (by others) must be inserted over the humidifier outlet pipes (fig.10). This will create a critical air gap at the drain connections.
NOTE: This air gap is critical for normal drain siphon operation.

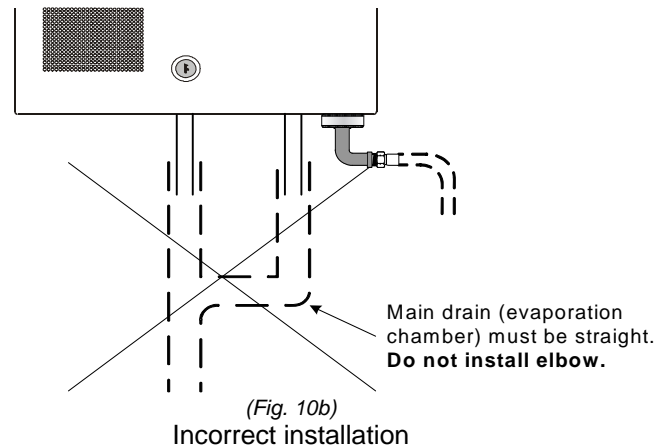
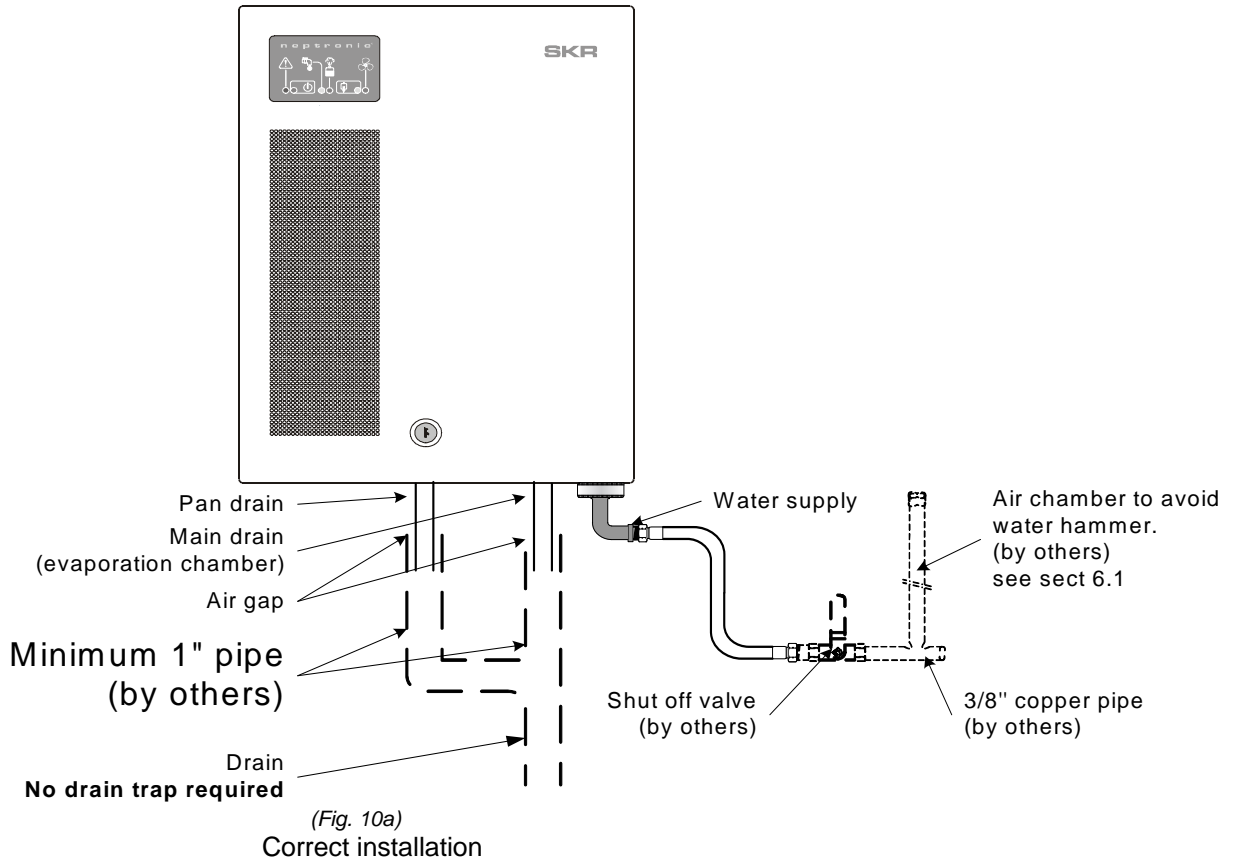



7. Power supply connections

- **CAUTION:**
 1. **RISK OF ELECTRIC SHOCK, TURN OFF POWER AT THE EXTERNAL BREAKER/FUSED DISCONNECT BEFORE PROCEEDING TO THE POWER SUPPLY CONNECTION.**
 2. **To reduce the risk of electric shock, do not connect to a circuit operating at more than 150V to ground.**
- **IMPORTANT:** The wiring to the humidifier should be done by a qualified electrician and conform to procedures, regulations and local codes.
- Ensure that the voltage required by the humidifier is the same as the available power supply.
- Ensure that the size of the wire conductors is appropriate for the current required by the humidifier.
- A dedicated external breaker/fused disconnect must be installed.
- The ground conductor must be equipped with ring terminal and be connected the indicated location (fig.11).
- Use coppers conductors only.
- Ensure that each terminal connection is properly secured.
- Install the supplied strain relief bushing at the bottom of the electrical compartment for of the supply cable.

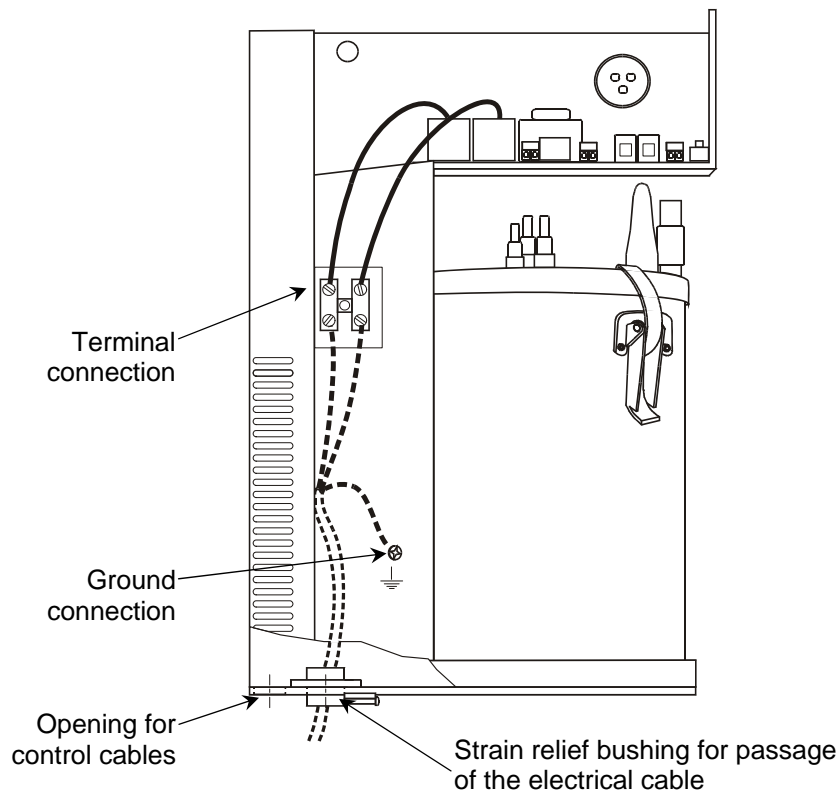

(Fig. 11)
Left side view



8. Control diagrams

IMPORTANT:

- 1 - Risk of malfunction. Do not supply power from external source to control terminals TB4 and TB5. These terminals are powered by the humidifier.
- 2 - Maximum length of each control cable is 250 feet (76m).

8.1. ON/OFF Humidifier (standard)

- ✓ Wire humidistat or Building Automation System signal to close on humidity drop below set point.
- ✓ Wire airflow switch to close when sensing air flow and open when no air flow is sensed.
- ✓ Wire high limit humidistat to close on drop in humidity and to open when set point is reached.

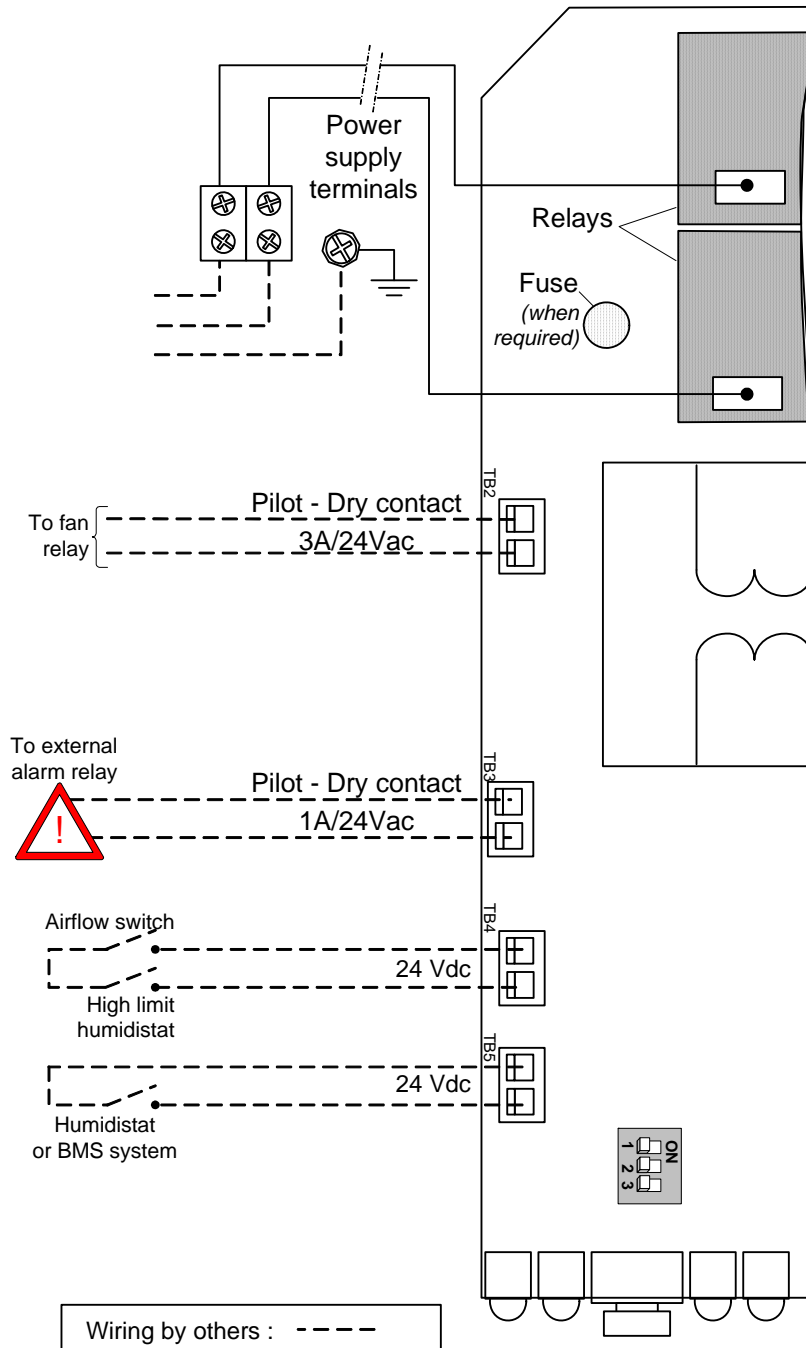

(Fig. 12a)



8.2. Modulating Humidifier

- ✓ Wire humidistat or Building Automation System signal to modulate steam output.
- ✓ Wire airflow switch to close when sensing air flow and open when no air flow is sensed.
- ✓ Wire high limit humidistat to close on drop in humidity and to open when set point is reached.
- ✓ Wire external cut-out, if required, to remotely switch off humidifier.

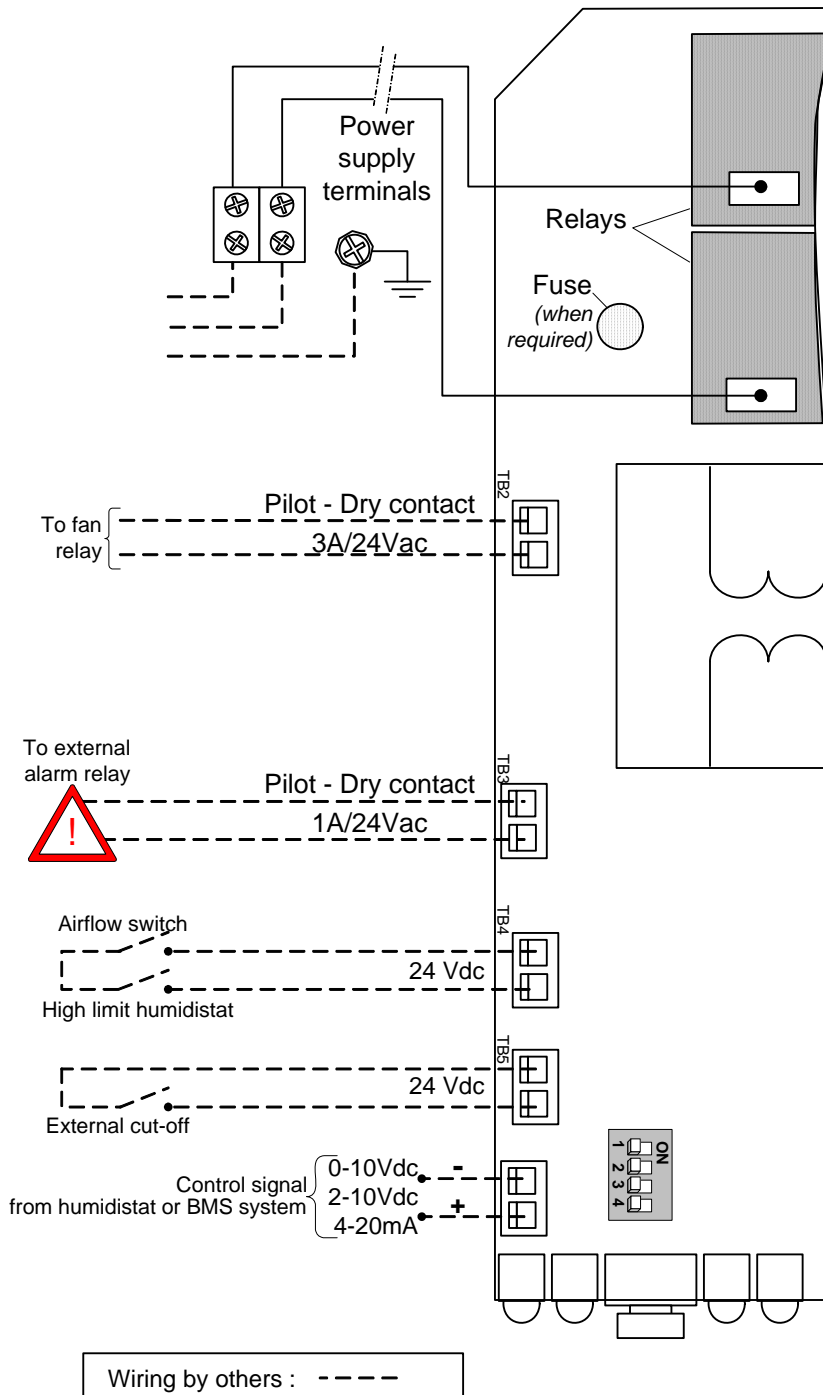

(Fig. 12b)

9. Control panel display



(Fig. 13)
Front panel



"ALARM" Indicator (red)

⊃○⊂ flashing	One or more abnormal conditions exist. (see section 16-Types of alarm)
⊃○⊂	Maintenance is required, the humidifier is OFF.
○	Normal operation.



"POWER" Push button and Indicator (green)

⊃○⊂	The push button is in the ON position.
⊃○⊂ slow flashing	The push button is in the OFF position and the humidifier is powered. (1 flash every 15 seconds).
○	Humidifier is not supplied with electric power.



"FILL" Indicator (yellow)

⊃○⊂	Water supply valve is open.
○	Water supply valve is closed.



"STEAM" Indicator (green)

⊃○⊂	Humidifier is producing steam at 100% capacity
⊃○⊂ flashing	Modulating humidifier only: Humidifier is modulating steam output according to the demand. Frequency of flashing is in proportion to the percentage of steam output.
○	Humidifier is not producing steam.



"DRAIN" Push button and Indicator (yellow)

⊃○⊂	Humidifier is in automatic or manual drain mode. <i>Press "DRAIN" push button to stop an on-going drain cycle.</i>
○	Drain mode is off.



"FAN" Indicator (green)

⊃○⊂	The contact to activate the ventilation system fan is closed.
○	The contact to activate the ventilation system fan is open.



10. Description of the control PC Board

The Printed Circuit Board is equipped with an advanced microprocessor, which controls all humidifier functions.

10.1. P.C. Board for ON/OFF Humidifier (standard)

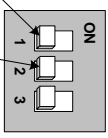
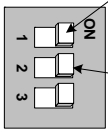
TB2	Dry contact (TB2) to connect to fan relay in order to activate the ventilation system fan on call for humidity (3amp, 24Vac).
TB3	Dry contact (TB3) for remote alarm annunciation (1amp, 24Vac).
TB4	Terminal to connect the airflow proving switch and the high limit humidistat (see fig.12a)
TB5	Terminal to connect the humidistat or Building Automation System (see fig.12a).
DS1	<p>Dip switches (DS1) setting:</p> <p>Drain every 2 hours of operation</p> <p>"Service required" alarm appear after 750 hours of operation</p>  <p>Drain every 6 hours of operation</p> <p>"Service required" alarm appear after 1500 hours of operation</p>  <p>(Fig 14b)</p> <p>Dip switch setting</p> <p>DS1-3 : Dip switch is not used</p> <p>Note: Depending on the local water conditions, service of the humidifier may be required prior to the "service required" alarm setting (see section 14, Maintenance).</p>

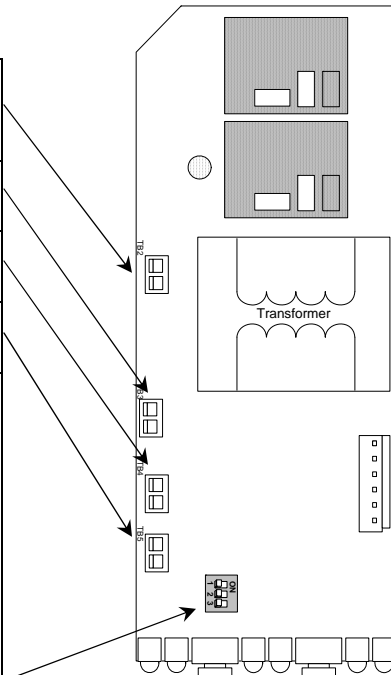

(Fig. 14a)
Top view

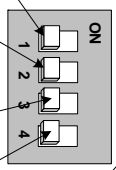
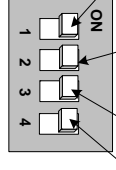

10.2. P.C. Board for Modulating Humidifier

TB2	Dry contact (TB2) to connect to fan relay in order to activate the ventilation system fan on call for humidity (3amp, 24Vac).
TB3	Dry contact (TB3) for remote alarm annunciation (1amp, 24Vac).
TB4	Terminal to connect the airflow proving switch and the high limit humidistat (see fig.12a)
TB5	Terminal to connect humidifier external cut-off.
TB6	Terminal to connect the humidistat or Building Automation System (see fig. 12b)
DS1	<p>Dip switches (DS1) setting:</p> <p>Drain every 2 hours of operation</p> <p>"Service required" alarm appear after 750 hours of operation</p> <p>No function attributed</p> <p>2-10 VDC control demand signal</p>  <p>Drain every 6 hours of operation</p> <p>"Service required" alarm appear after 1500 hours of operation</p> <p>No function attributed</p> <p>0-10 VDC control demand signal</p>  <p>(Fig 15b) Dip switch setting</p> <p>DS1-3 : Dip switch is not used</p> <p>DS1-4: For 4-20mA input signal, set the dip switch to the OFF position and connect the supplied 500 ohm resistor between the + and – of the terminal block TB6.</p> <p>Note: Depending on the local water conditions, service of the humidifier may be required prior to the "service required" alarm setting (see section 14, Maintenance).</p>

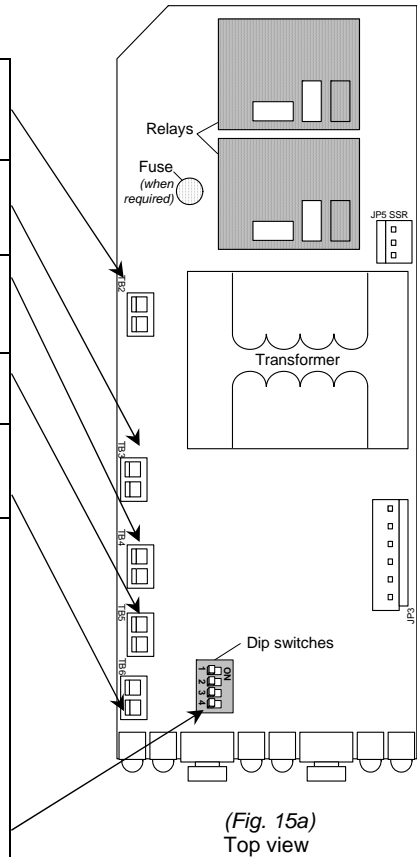



11. Start up procedure

Follow this start-up procedure to avoid improper system operation:

1. Ensure that steam distribution, electrical and plumbing connections have been done in accordance with the instructions in this manual.
 - a) Remove the humidifier cover.

CAUTION: RISK OF ELECTRIC SHOCK, ENSURE THAT THE POWER IS TURNED OFF BEFORE REMOVING THE COVER.
 - b) Ensure that the control wiring has been made in accordance with the instructions in this manual.
 - c) Ensure that dip switches (section 10, DS1) are correctly set.
 - d) Verify that the drain connections are connected to an open main drain of sufficient diameter.
 - e) Re-install the humidifier cover.
2. Open the water shut off valve (external to the humidifier).
3. Turn on the power to the humidifier at the breaker/fused disconnect. The "POWER" indicator, located on the control panel, will flash.
4. Press the "POWER" push button located on the control panel. The "POWER" indicator will stay on continuously.
5. Perform a manual cleaning cycle:
 - a) The fill cycle is activated automatically when the evaporation chamber does not contain water.
 - b) When the "FILL" indicator is off, press the "DRAIN" push button.
 - c) The "DRAIN" indicator will come on and the water will drain from the evaporation chamber.
 - d) The evaporation chamber will fill with water and drain again.
 - e) When the "DRAIN" indicator turns off, press on the "POWER" push button.
 - f) Repeat steps "b" through "e" one more time to ensure proper cleaning of the evaporation chamber.
6. Your humidifier is now fully operational. No other action is necessary; your SKR humidifier will produce steam upon demand from control(s).

12. Description of operation of the SKR

- Press the "POWER" push button (if the indicator is flashing) to start the humidifier ("POWER" indicator will light continuously). If the evaporation chamber does not contain water, the fill cycle is activated automatically ("FILL" indicator is on).
- If there is no demand from the humidity controller, the humidifier is in a standby mode ("STEAM" indicator is off).
- On a demand of humidity, the contact to activate the ventilation system fan closes ("FAN" indicator is on) and the relays close to power the electric element in the evaporation chamber ("STEAM" indicator is on).
- The water in the evaporation chamber will start to boil and evaporate. The steam is released through the opening in the cover of the evaporation chamber. The steam will travel in the flexible steam hose and disperse inside the supply duct through the steam dispersion tube.
- During the evaporation sequence, a certain amount of water is evaporated. The water supply valve will open to replenish the water in the evaporation chamber.
- Depending on the selected drain period (section 10, fig.16b, DS1-1), the water in the evaporation chamber will be drained ("DRAIN" indicator is on) to renew the water and to evacuate the minerals inside the evaporation chamber.
- The SKR operates at full capacity until the programmed humidity level set point is reached. When the set point is reached, the humidifier will revert to standby mode. The contact to activate the ventilation system fan (section 10, fig.16a, TB-2) will remain closed for a period of four minutes after steam production has stopped.
- When the humidity level is below the set point, the humidifier will produce steam again. If there is no humidity demand for a period of more than 72 hours, the humidifier will drain the water from the evaporation chambers automatically and go into standby mode



13. Shut-down procedure

During seasonal shut down, the humidifier should be placed out of service.

1. Press "**DRAIN**" push button to empty the water from the evaporation chamber, the "**DRAIN**" indicator will be on.
2. Once the cycle has ended, the "**DRAIN**" indicator will turn off. Close the shut off valve (external to the humidifier) on the water supply line.
3. Open the main power breaker/fused disconnect switch to the humidifier.

14. Maintenance

14.1. General

- **IMPORTANT:** Failure to perform the required periodic maintenance will void the warranty.
- The required cleaning frequency can vary from every 2 months to once a year depending on local water conditions.
- The **SKR** humidifier is equipped with an internal operating hour counter and a "service required" alarm. Depending on the local water conditions, service of the humidifier may be required prior to the "service required" alarm setting (section 10, DS1-2).
- The routine service is a cleaning of the evaporation chamber.

14.2. Evaporation chamber cleaning

CAUTION: RISK OF BURN. THE EVAPORATION CHAMBER AND ITS CONTENTS CAN BE EXTREMELY HOT, CHECK TEMPERATURE BEFORE HANDLING.

1. Cooling down and draining of the evaporation chamber.

- a) Press "**DRAIN**" push button on the control panel. The humidifier will initiate a drain cycle. The "**DRAIN**" indicator will turn on.
- b) The "**DRAIN**" indicator is on and the water is drained from the evaporation chamber.
- c) The evaporation chamber will refill with water and drain again.
- d) When the "**DRAIN**" indicator turns off, the "**POWER**" indicator will begin to flash.
- e) Check the temperature of the evaporation chamber. If it is cool enough go to step #2 below, otherwise repeat draining of the evaporation chamber (step #1) until is cold enough.

2. Shut down of the electrical supply.

CAUTION: RISK OF ELECTRIC SHOCK, TURN OFF POWER AT THE EXTERNAL BREAKER/FUSED DISCONNECT BEFORE SERVICING.

- a) Remove the cover of the **SKR** Humidifier.

3. Disconnecting the heating element.

- a) Unscrew the high voltage quick connect (see fig.2), located on the right side of the electrical compartment.

4. Disconnecting the high temperature switch.

- a) Disconnect the high temperature switch quick connect (see fig.2).

5. Disconnecting the steam hose and the water pipe.

- a) Loosen clamp on the steam hose connection.
- b) Remove the steam hose from the top of the evaporation chamber.
- c) Unscrew the water piping coupling located on the lower right hand side of the evaporation chamber.

6. Removing the evaporation chamber.

- a) Remove the evaporation chamber from the humidifier cabinet.



7. Opening the evaporation chamber.

- a) Unfasten the 3 latches located around the evaporation chamber.

Caution: Risk of injury, latches are tight. It is recommended to use pliers or a screwdriver to unfasten the latches.

- b) Remove the cover from the evaporation chamber.
- c) Do not misplace the gasket located between the cover and the cylinder.

8. Cleaning the evaporation chamber.

- a) Pour out any remaining water and scale from the bottom of the evaporation chamber
- b) Clean out the remaining scale, use a non-metallic brush and water. Some vinegar or any weak acid for cleaning stainless steel may be required.

IMPORTANT: The use of wire brush or any non-recommended acid will void the warranty.

- c) If the amount of scale to be removed is significant, the service required alarm setting and/or the drain rate (section 10, DS1) may be set too high for the local water conditions. Too much scale may impair the normal operation of the humidifier or damage it. In this case, increase the frequency of maintenance as necessary.

9. Cleaning the electric element and cover.

- a) The cover of the evaporation chamber and element will, in general, not require cleaning. However, if cleaning is required, proceed as per the cleaning of the evaporation chamber.

IMPORTANT: The use of wire brush or any non-recommended acid will void the warranty.

10. Checking the gasket

- a) Check the gasket. The gasket should not be cracked.
The gasket must be replaced a minimum at every second maintenance of the evaporation chamber or after one year of operation. Replace more frequently if required.

11. Reassembling the evaporation chamber.

- a) Rinse out the cylinder and the cover with water.
- b) Place the gasket inside the cover before installing the cover on the evaporation chamber.
- c) Align the dimple on the cover with the latch located nearest to the water drain/fill coupling (fig.2).
- d) Tighten the three latches around the cover.
- e) Replace the evaporation chamber in the humidifier.
- f) Tighten the water drain/fill coupling.
- g) Replace the steam hose on the outlet of the evaporation chamber and secure steam hose with the clamp.
- h) Reconnect the high temperature switch connector and the high voltage connector of the heating element.

CAUTION: RISK OF OVERHEAT AND FIRE, MAKE SURE THE HIGH VOLTAGE CONNECTOR IS PROPERLY LOCKED.

- i) Replace the cover on to the humidifier and lock it.

12. Start-up of the humidifier.

- a) Close the main power breaker/fused disconnect switch to the humidifier.

Reset of the operating hours to zero: Press "POWER" push button to turn OFF the humidifier, if necessary, then press and hold the "POWER" and "DRAIN" push buttons for ten seconds (section 16-Types of alarm, Reset).

- b) Press the "POWER" push button. The "POWER" indicator on the control panel will light.
- c) The humidifier will go into a fill cycle; the "FILL" indicator will be on.
- d) If there is a humidity demand, the humidifier will produce steam.



15. Exploded View and Bill of Material

15.1. Exploded view

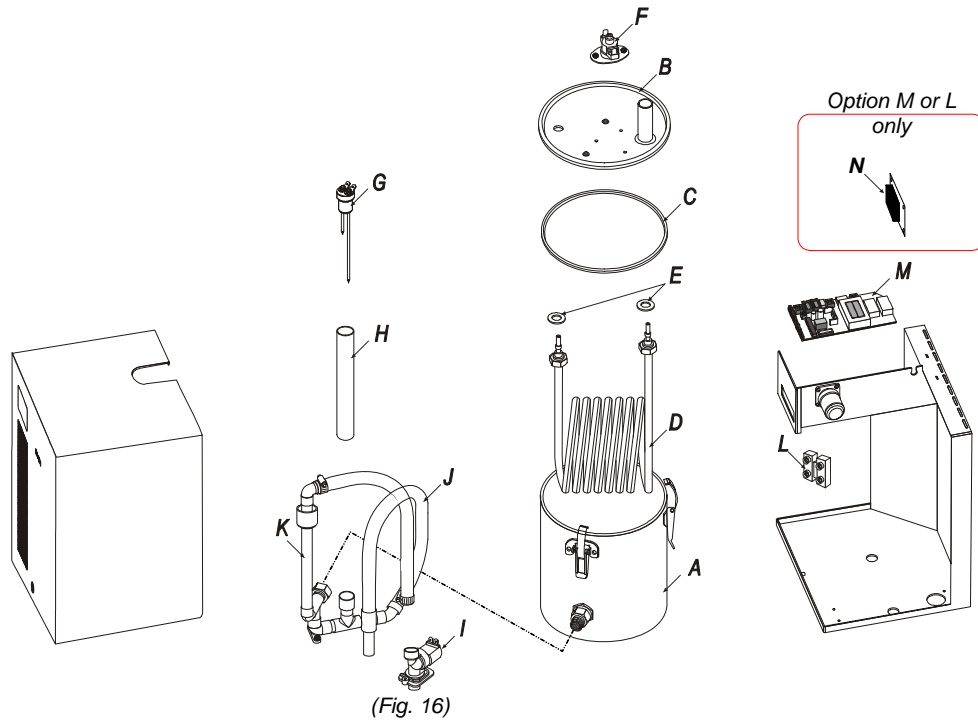

15.2. Bill of Material

Item	Description	Model	Part number
A	Evaporation chamber cylinder	SKR-14 / 25 / 30 / 40	SW SKRCONT-ASSY
B	Evaporation chamber cover	SKR-14 / 25	SP 9011
		SKR-30 / 40	SP 9012-M
C	Evaporation chamber gasket	SKR-14 / 25 / 30 / 40	SP 9030
D	Heating element	SKR-14	SE 5990
		SKR-25	SE 5991
		SKR-30	SE 5992
		SKR-40	SE 5993
E	Heating element gasket	SKR-14 / 25 / 30 / 40	SP 1005
F	High temperature switch	SKR-14 / 25 / 30 / 40	SP 3035
G	Water level sensor assembly	SKR-14 / 25 / 30 / 40	SW SKRLEV-ASSY
H	Water level sensor tube	SKR-14 / 25 / 30 / 40	SP 1025
I	Water fill valve	SKR-14 / 25 / 30 / 40	SP 6004
J	Drain pipe assembly	SKR-14 / 25 / 30 / 40	SW SKRDRAIN-ASSY
K	Main plumbing assembly	SKR-14 / 25 / 30 / 40	SW SKRPIPE-ASSY
L	Terminal block	SKR-14 / 25 / 30 / 40	SP 9046
M	Main PC board – ON/OFF	SKR-14	NW SKR120MAIN-NSS
		SKR-25 / 30 / 40	NW SKR240MAIN-NSS
	Main PC board – Modulating	SKR-14M	NW SKR120-M-NSS
		SKR-25M / 30M / 40M	NW SKR240-M-NSS
N	SKR-TRIAC PC board (option M)	SKR-14M / 25M / 30M	NW SKRET-2SS
		SKR-40M	NW SKRET-3SS
	SKR-TRIAC PC board (option L or ML)	SKR-14 / 25 / 30	NW SKRL-2SS
		SKR-40	NW SKRL-3SS



16. Types of alarm

CAUTION: RISK OF ELECTRIC SHOCK, POWER MUST BE TURNED OFF AT THE EXTERNAL BREAKER/FUSED DISCONNECT BEFORE REMOVING THE COVER OF THE HUMIDIFIER.

- **IMPORTANT:** A corrective action must be taken before doing a reset.
- The alarm contact (normally open) will close when there is an alarm.

ALARM Indicator	Condition	Consequences	Corrective actions	Reset
Service required 1. Flashing continuously	Operating hours exceeded the service required alarm hour setting (DS1-2)	Alarm. No interruption of the operation of the humidifier	Proceed to a service (See section 14-Maintenance)	<ul style="list-style-type: none"> • Press the "POWER" push button to turn OFF the humidifier (if necessary). • Press and hold "DRAIN" and "POWER" push buttons simultaneously for ten seconds. These two indicators will turn on after the ten seconds. Release the push buttons.
Service required 2. Indicator is continuously on <i>(SKR Humidifier shut off)</i>	Operating hours exceeded by more than 50 hours the service required alarm setting (DS1-2)	Alarm. The operation of the humidifier is interrupted	Proceed to a service See section 14-Maintenance)	<ul style="list-style-type: none"> • Press the reset button on the high temperature switch device located on the evaporation chamber cover.
High temperature 2 flashes + pause	Temperature in the evaporation chamber exceeded the preset temperature of the high temperature switch	Alarm. The operation of the humidifier is interrupted	<ul style="list-style-type: none"> • Check that the static pressure inside the duct at the steam dispersion tube does not exceed 0.5" W.G. (125Pa). • Check that the steam hose is not blocked or kinked. • Check that the water connection on the evaporation chamber is not blocked. 	<ul style="list-style-type: none"> • Press on the DRAIN push button
Drainage 3 flashes + pause	Drainage sequence is not correct	Alarm. The operation of the humidifier is interrupted	<ul style="list-style-type: none"> • Check that the water connection to the evaporation chamber is not blocked. • Check that the drain piping is not blocked. 	<ul style="list-style-type: none"> • Check that the shut off valve installed on the supply water line is open. • Verify the operation of the fill valve. • Check that the fill valve strainer and the external strainer are not blocked.
Fill 4 flashes + pause	Time to fill the evaporation chamber exceeded the preset time in the microprocessor	Alarm. The power to the heating element is interrupted	<ul style="list-style-type: none"> • Check that the sensors are properly connected. • Check that the sensors are clean. 	<ul style="list-style-type: none"> • Check that the main power breaker or fused disconnect switch is closed
Level sensors 5 flashes + pause	The level sensors do not detect the water level correctly	Alarm. The operation of the humidifier is interrupted	<ul style="list-style-type: none"> • Check that the sensors are properly connected. • Check that the sensors are clean. 	<ul style="list-style-type: none"> • Check that the main power breaker or fused disconnect switch is closed
Power Not flashing	The unit is not powered	–	<ul style="list-style-type: none"> • Check that the main power breaker or fused disconnect switch is closed 	<ul style="list-style-type: none"> • Check that the main power breaker or fused disconnect switch is closed

17. Troubleshooting guide

Problem	Causes	Corrective actions
<p>The humidifier does not operate (no alarm)</p>	<ul style="list-style-type: none"> • The humidifier is not powered. • Airflow is not detected by the airflow proving switch. • Ventilation system fan is not operating. • The airflow proving switch is not detected or not operational. • The high limit duct humidistat is not operational (if available). 	<ul style="list-style-type: none"> • Check for the main power supply and fuses. • Check that the sensor tube is connected properly inside the duct and to the airflow switch. • Check that the airflow switch and the high limit duct humidistat (if available) are located properly. • Check the fan operation.
<p>The humidifier does not operate (alarm indicator flashing)</p>	<ul style="list-style-type: none"> • Check the alarm indicator to determine the cause 	<ul style="list-style-type: none"> • See section 16-Types of alarm to correct the situation
<p>The duct downstream of the dispersion tube is wet</p>	<ul style="list-style-type: none"> • The installation of the steam dispersion tube is incorrect. • The capacity of the humidifier is too high. • The high limit humidistat is not installed properly or is defective (if available). 	<ul style="list-style-type: none"> • Check if the steam dispersion tube is installed correctly. • Install a high limit duct humidistat if required. • Verify the installation and the operation of the high limit duct humidistat (if available).
<p>Water accumulation under the humidifier</p>	<ul style="list-style-type: none"> • The drain pipes are leaking, are obstructed or the slope is incorrect. • A drain trap is installed on the drain line. • The water supply connection is leaking. • The installation of the flexible steam hose is incorrect. • Evaporation chamber is leaking steam. 	<ul style="list-style-type: none"> • Check all the couplings and drains under the unit. • Remove all drain traps. • Check water supply circuit. • Check that the clamp on the steam hose is properly tightened on the steam outlet of the evaporation chamber. • Check the condition of the evaporation chamber gasket inside the evaporation cover.



18. Electrical diagram

18.1. ON/OFF Humidifier (standard)

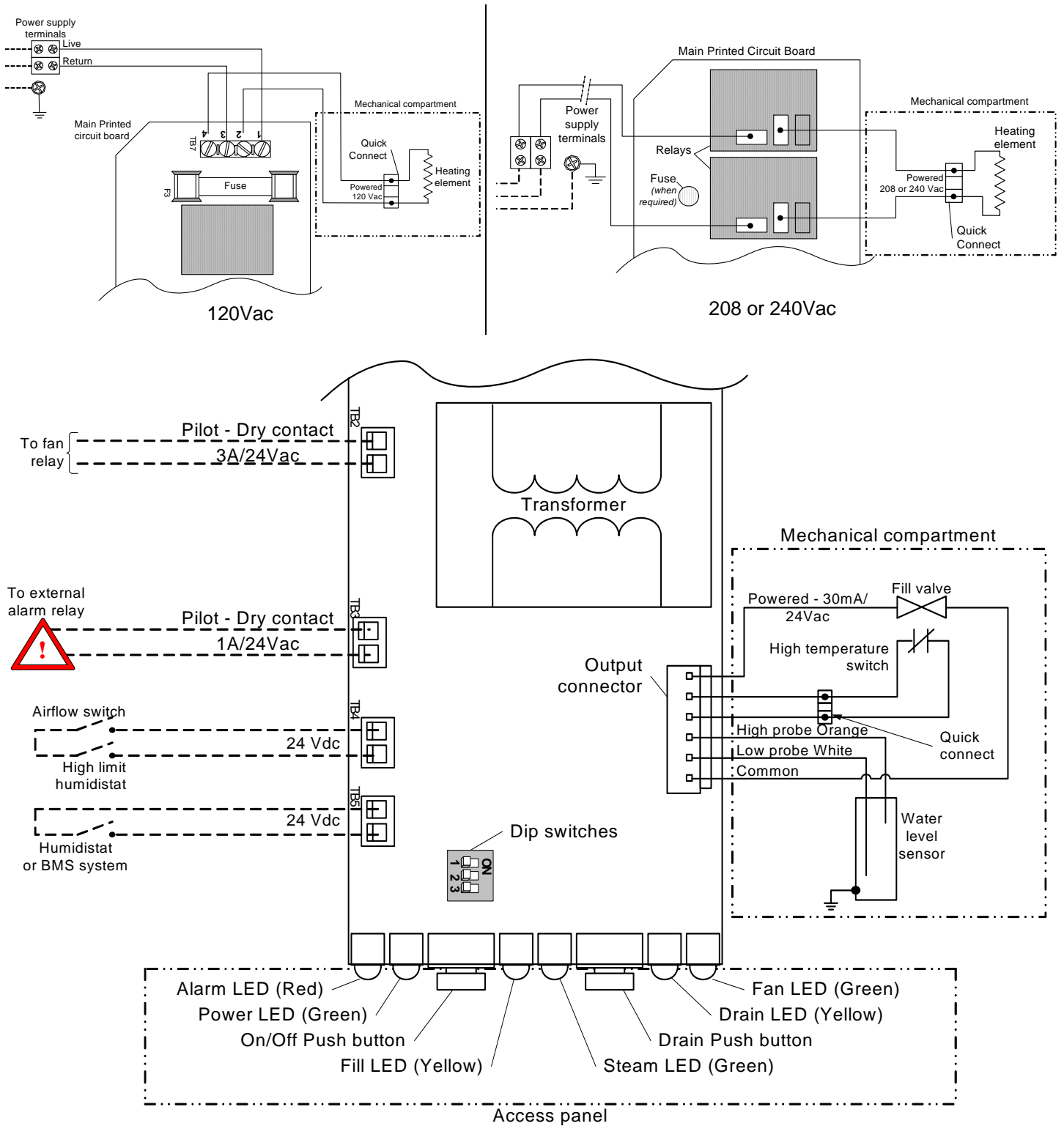

(Fig. 17a)



18.2. Modulating Humidifier

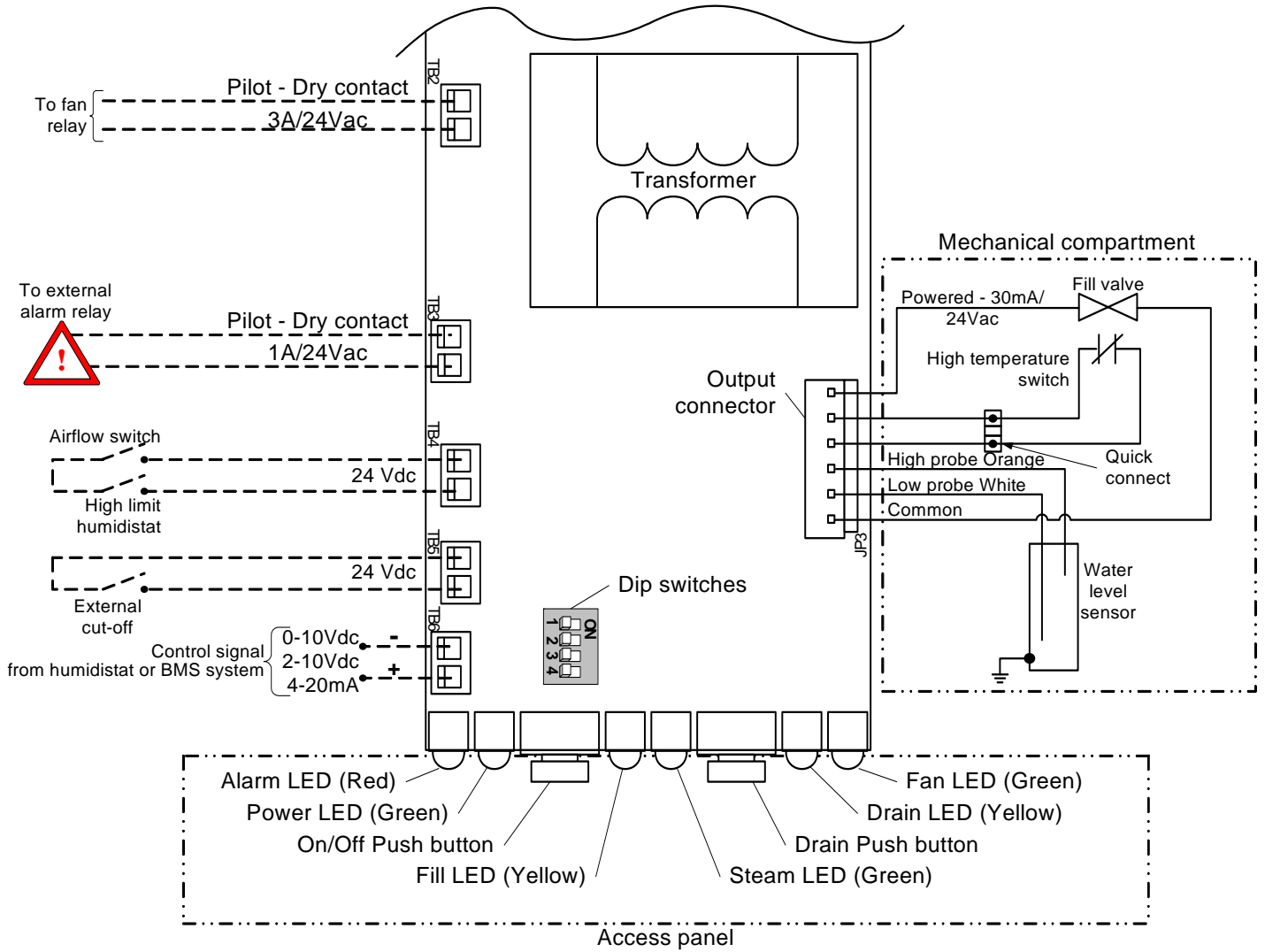
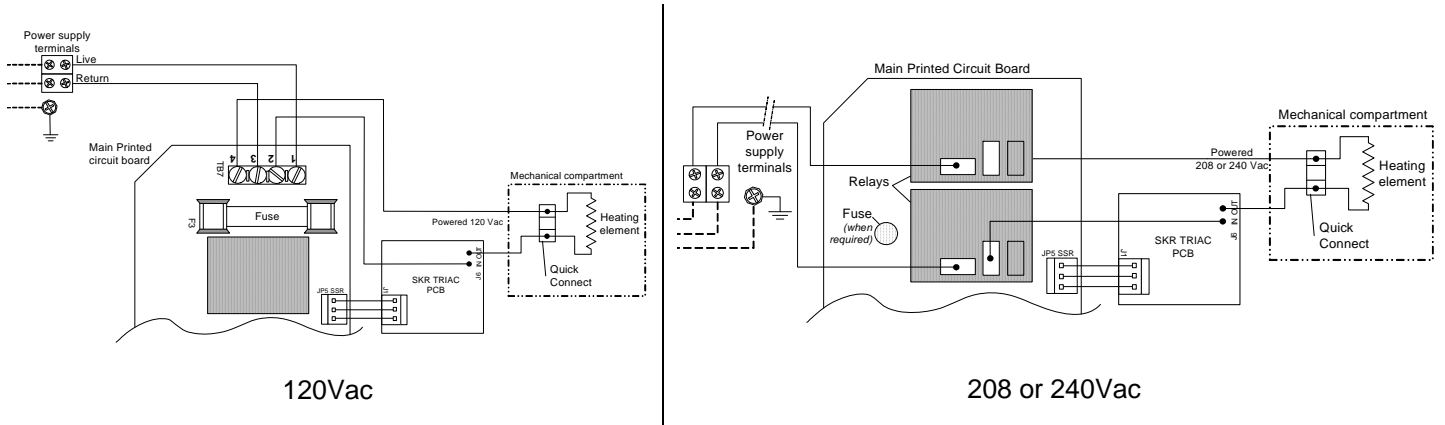

(Fig. 17b)



18.3. Modulating humidifier with HRO20

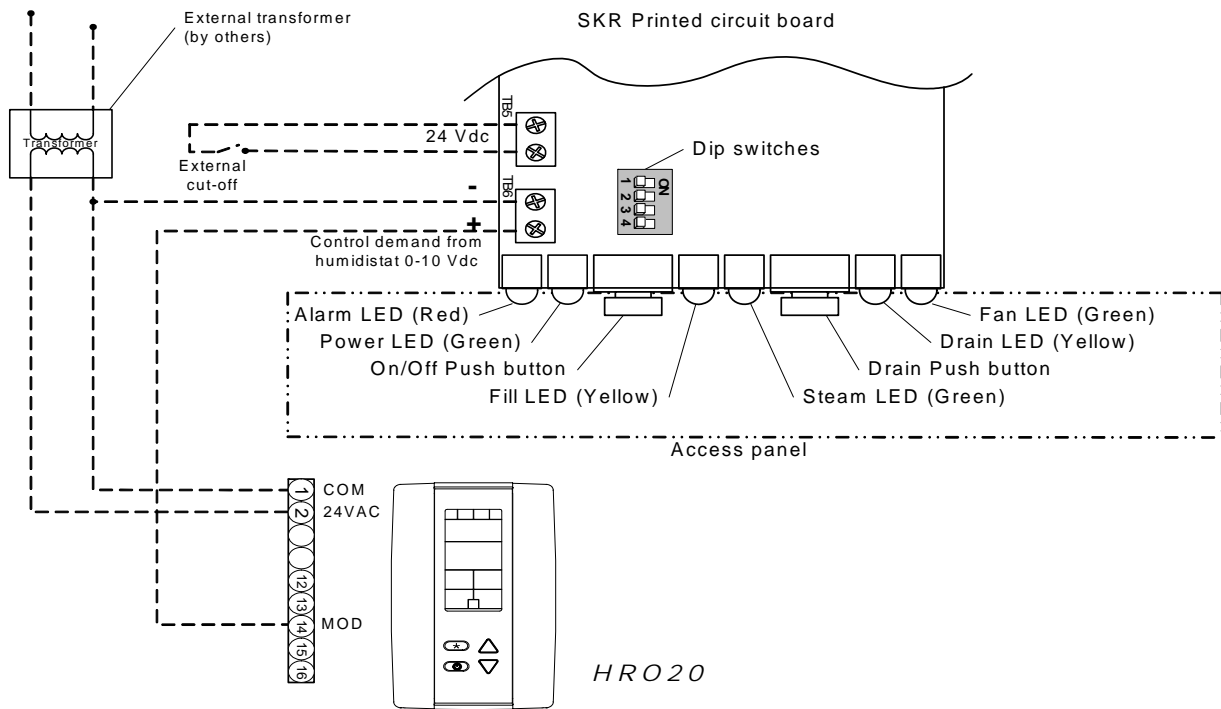

(Fig. 17c)

18.4. Modulating humidifier with HRO20 and SHR10 or SHC80

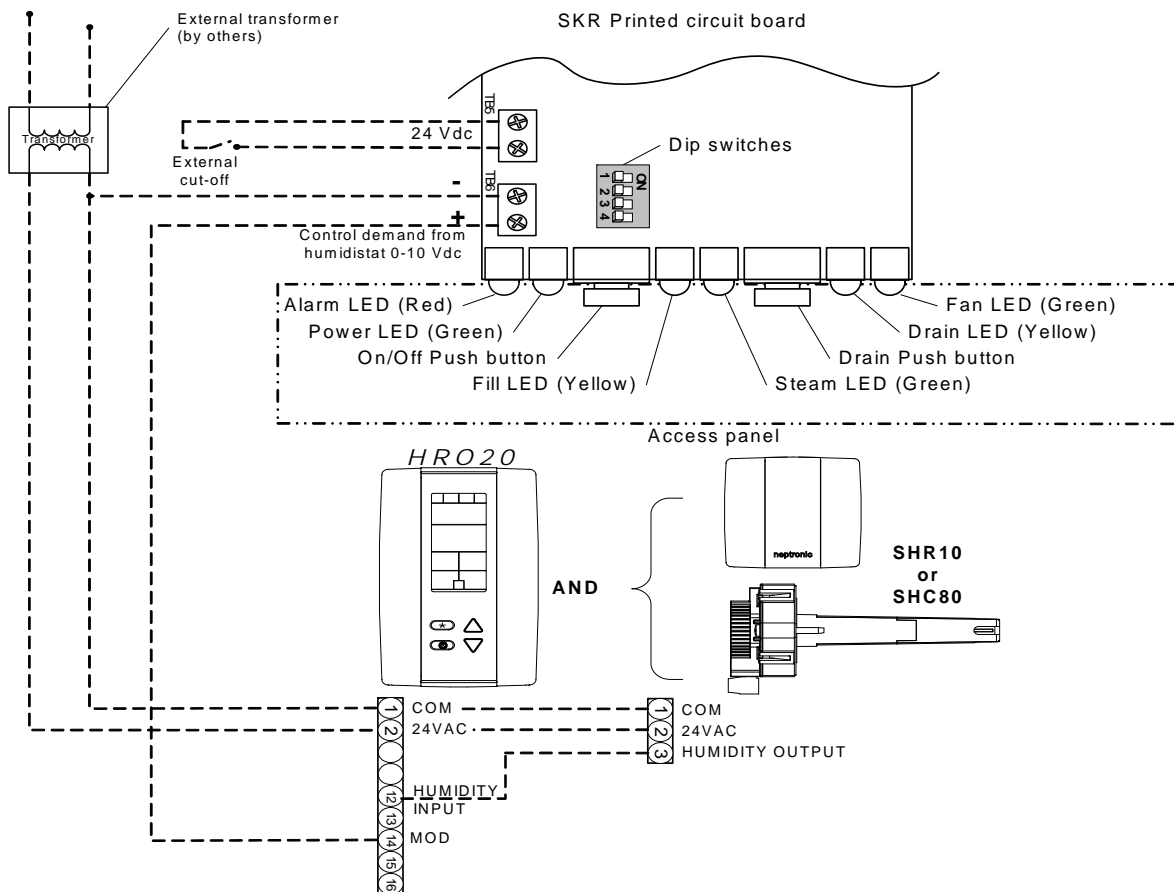

(Fig. 17d)



1. General

Unless otherwise arranged, in writing, the acceptance of the Order Confirmation by the purchaser includes acceptance of the "General Conditions of Sale and Warranty" of National Environmental Products, Ltd hereafter referred to as NEP.

2. Incoterms

The international rules for interpretation of trade terms "Incoterms" as defined by the ICC Incoterms publication no. 460 from 1990, shall apply to the commercial terms used herein.

3. Confirmation of Order

- NEP shall not be deemed to have accepted an order until written "Order Confirmation" from NEP is issued to the purchaser.
- It is the responsibility of the purchaser to verify that all information concerning his/her order is correct and to notify NEP in writing, of any discrepancy prior to the order being shipped. In the event of a change or correction to an existing order, a second "Order Confirmation" will be issued by NEP.

4. Price

- Our prices are net, Ex-works Montreal in U.S. Currency, unless stated otherwise.
- Minimum orders shall be \$50.00 minimum.
- Shipping and Handling charges are \$5.00 minimum per order unless the shipment is billed to the purchaser's account or shipped freight collect.
- NEP reserves the right to adjust accepted prices in the event of alterations in rates of exchange, variations in costs of materials, changes in wages, interference on the part of the Government or similar conditions over which NEP has no control.

5. Payments terms

- Major credit cards, C.O.D., Prepayment.
- For open account, invoices are payable within 30 days from the date of invoice without no deduction, unless specify otherwise.
- An interest charge of 2% per month will be included on all overdue payments.
- No new order will be process if invoices are not paid within 45 days.

6. Transfer of ownership

The goods shall remain the property of NEP until the full payment for the goods has been received by NEP.

7. Delivery terms

- Shipments are Ex-works **400 Lebeau, St Laurent, Quebec, H4N 1R6, CANADA** unless notified otherwise.
- Unless special instructions, the order will be delivery in the way which NEP deems best without guaranteeing this to be the cheapest way of transport.
- For International Order, a written designation naming the freight forwarding agent is required and will remain in effect until notified otherwise.
- Any discrepancy, damage or breakage should be reported in writing both to NEP and to the Carrier within 5 working days from the receipt date.

8. Risk

From the moment of delivery, the purchaser shall bear all risks for the goods and NEP shall not be responsible for loss and damage incurred during transportation.

9. Delivery time

- Delivery time is stated approximately and depends on the product ordered, please allow a minimum of:
 - a) 2 weeks for processing North American order.
 - b) 6 weeks for processing International order.
- We will make every effort to adhere to our delivery promises, but will not accept order or contract cancellation or any liability for any direct or indirect losses that may arise for any reason whatsoever as a result of our failure to adhere to such promises.

10. Return of good

- Goods received by the purchaser cannot be returned unless a completed "R.M.A. Form" (Return Material Authorization Form) has been issued by NEP's **Customer Service**.
- Any returned goods must be sent to NEP 400 Lebeau, St Laurent, Quebec, H4N 1R6, CANADA, unless stated otherwise by the R.M.A. Form, accompanied with the completed "R.M.A. Form", the **R.M.A. number** shall be prominently displayed on the shipping box. Unauthorized returns will be refused.
- Any returned goods must be sent freight prepaid. Any goods that come to us freight collect will be refused and returned to sender unless previously agreed to by us in writing on the "R.M.A. Form".
- Goods returned for credit shall be in condition for resale in the original box and properly packaged. Units, accessories or components that have been installed are not returnable and not refundable. Credit is subject to an overhead charge of 30% of the invoice plus shipping & handling if returned within 30 days of the invoice date and 50% from 30 to 60 days.
- Non standard product (SK units with special feature), Multisteam manifolds and any DI unit are not returnable and not refundable.

11. Warranty

- Provided that the terms of payment are observed, the purchaser is offered a warranty of **24 months** from the original purchase date of delivery for any NEP's **standard product**, provided the equipment has been properly installed and operated in accordance with NEP instructions.
- The warranty covers faulty manufacture, design and/or defective materials and is limited to the equipment and components. The warranty shall cease to be valid in the event of misapplication, incorrect installation, **improper maintenance** or any other incorrect uses or misuse of the product.
- For the SK series, the warranty furthermore ceases to be valid if the user disconnects or removes any electronic or mechanical components prior disconnecting the input power. NEP assumes no responsibility for repairs made on equipment, unless performed by NEP's authorized personnel.
- The defective product or component shall be returned in accordance with the paragraph 10 (Returns of goods) as described in this document.
- NEP agrees under the warranty to repair or replace (at the discretion of NEP) such standard product or component, which upon examination by NEP are found to be defective.
- Product or component replaced or repaired under warranty will be sent back to the purchaser, standard freight paid by NEP
- Expenses in connection with traveling time, dismantling and mounting shall not be paid by NEP
- Guarantee for products or components sold but not manufactured by NEP, is only given to the same extent as given to NEP, however, not exceeding the normal NEP warranty.
- Parts used for repairs are warranted for the balance of the term of the warranty on the original humidifier or 90 days, whichever is longer.
- Any repair made, after the original warranty period, at the NEP facilities are warranted for 1 month from the date of repair.

12. Proper law and jurisdiction

This contract is and shall be deemed to have been made in the province of Quebec, CANADA, and shall in all respects, be governed by the province of Quebec laws.