

U220 User Manual

1. Preface

Thank you for purchasing the Gsou U220 portable stereo Bluetooth® speaker. Please take the time to follow the instructions in this user manual carefully. If you have any questions , please call our national service hotline: 400-0985-400

2. Warnings and Cautions

1. To reduce the risk of fire or electric shock, be sure the electrical circuits are not overloaded.
2. To reduce the risk of electronic shock, be sure not plug the adapter with wet hands.
3. Unplug the power cable if your device is smoking or abnormal and seek professional help from your nearest service center, be sure not detach the device yourself.
4. To reduce the risk of fire or electric shock, do not expose this product to rain or moisture. Liquids can cause a failure and/or a fire hazard.
5. In order to prevent a short circuit , the power cable and audio cable should not be twisted or dragged in case of short circuit.
6. Do not place the speaker near any open flame sources, such as lighted candles.
7. The safety temperature of Lithium Battery should not exceed 80°C

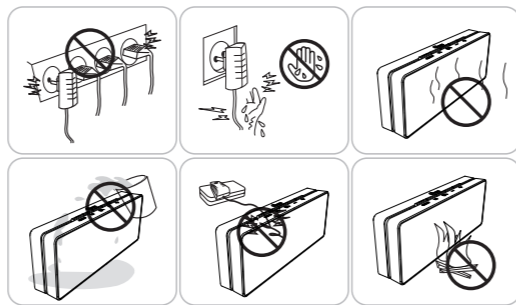

3. Standard Accessories

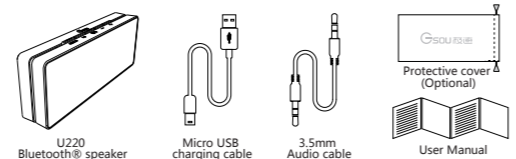

4. Structure Introduction

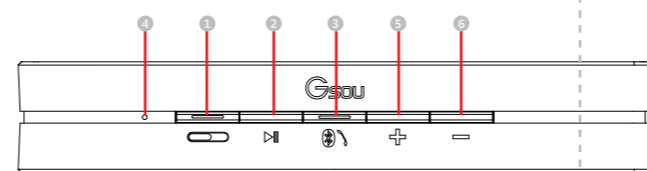

- ① Power on / Off : Red light flashes means your speaker needs to be charged , Red indicator is on when charging , and off when fully charged .
- ② Play / Pause button
- ③ Bluetooth status indicator , Answer/reject call
 1. Blue indicator flashes : Indicates that device is waiting for a connection
 2. Blue indicator remains steadily on : Indicates that device is connected to an Aux in devices
 3. Short press the hand free key to answer an incoming call and short press it again to hang up!
- ④ Mic
- ⑤ Previous / next track , Volume Up / down : short press is for next track , long press is for increasing volume
- ⑥ Previous / next track , Volume Up / down : short press is for previous track , long press is for decreasing volume
- ⑦ AUX in Jack : Connect the U220 with your PC, MP3/mp4 player, Tablet, Mobile and other playback devices with 3.5mm jack by audio cable and U220 will disconnect the Bluetooth® automatically
- ⑧ Reset Button : If the speaker is unresponsive, use 1.0mm pin or probe to press reset button .
- ⑨ DC IN

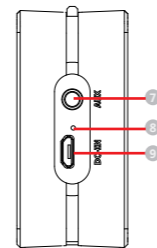

5. Structure Introduction

Blue indicator flashes	status of waiting for connecting
Blue indicator remains steadily on	connected to Bluetooth® source or connected to aux in devices
Low power indicator flashes	battery voltage lower than 3.3V , Red light flashes means your speaker needs to be charged
Red charging indicator light	Red indicator is on when charging , and off when fully charged .

6. Operation steps

1. How to connect your U220 with Bluetooth-enabled playback devices?

- ① Be sure your speaker battery has sufficient power.
- ② Turn on your speaker and it will be in Bluetooth mode automatically and ready for connecting. The blue indicator flashes
- ③ Open the Bluetooth® on your mobile, search the "Gsou U220" device and connect to it. No password is needed for most of Bluetooth playback devices, but due to varying Bluetooth versions, sometimes, you need to

- input the default password "0000" (four zero) if required.
- ④ Blue light remains steadily on to indicate successfully connected.
- ⑤ Run the music player of your mobile, and enjoy the loud but clear sound from your U220.
- ⑥ You need to disconnect the previous pairing Bluetooth® device , then other mobiles can be available

2. How to connect the U220 with your notebook PC by Bluetooth® (1) connecting to a Bluetooth® enabled notebook.

- ① Start your notebook, and search for the Bluetooth® device by "Start—Setting—Control Panel" .
 - ② Start the Bluetooth® searching function of your notebook, blue light flashes when searching the Audio-in devices.
 - ③ Blue indicator light remains steadily on after connecting successfully.
- (2) Connecting to a notebook without Bluetooth® function.
- Please buy a Bluetooth® adaptor separately. We suggest an adaptor with Bluetooth version 4.0 for the high quality audio experience. After installing please start the Bluetooth® from the "Control Panel" or the shortcut on your pc desktop, please search for connecting, and the instruction steps are the same as the first case.

3. How to play music via AUX-in?

- ① Make sure your speaker power on
- ② Your U220 comes with a standard 3.5mm Aux in jack for connecting with other non-Bluetooth audio devices, eg mobile phones, mp3/mp4 players, pc, tablet pc and etc.
- ③ Your speaker will disconnect the Bluetooth®, switches to the external source play, as the external source of AUX-in mode is prior
- ④ Have connected the AUX model before you use the speaker , needs switch to other play mode . Please short press M key , turn the present mode to the other you wanted .
- ⑤ Long press the Volume Up / Down to operate your speaker

4. NFC power on/pairing. (Make sure your mobile phone has NFC function.)

- ① Press the power button to switch on
- ② Start your NFC from the settings area of your phone.
- ③ Tap your mobile phone to NFC area of the speaker. Your speaker will power on automatically. The indicator will flash.
- ④ Five seconds later, tap your mobile to the NFC area again to activate NFC pairing. Choose yes when your speaker mobile shows: Pairing with

Bluetooth" ?

- ⑤ Your mobile phone will indicate "Paired with Gsou U220" , you can now enjoy wireless music.
- ⑥ Tap your mobile phone to the NFC area again to disconnect Bluetooth.

7. How to charge

Using a USB cable to connect to a computer or buy USB charger

8. Specifications

Bluetooth version	4.0
Bluetooth profiles	A2DP,AVRCP,HFP,SPB,BAS,DIS,FMP,HRP,HRS,HTP,HTS,IAS,LSS
Working distance	about 33 feet
Loudspeaker	ø45mm 4Ω / 5W
Frequency response	100HZ - 20KHZ
RMS	5W x 2CH
Sensitivity	80db
S/N ratio	≥ 60db
Distortion	≤ 0.4%
Battery	Built-in 1000mAh rechargeable lithium battery
Working voltage	3.7V-4.2V
Charging voltage	DC 5V /1A
Charging current	400-500mA
Size	L160*W60*H28 mm
Net Weight	276g

9. Trouble shooting and FAQ

1. Bluetooth Pairing and Connecting

- Pairing occurs when two Bluetooth® devices communicate with each other and establish a Connection .
- Connecting occurs when two Bluetooth ® devices are matched and ready to share data .
- The two devices can be shared under the connecting status , pairing speaker can not work .

2. Your mobile search the Gsou U220, but the speaker it' s not playing

- Make sure your speaker is in the Bluetooth mode
- Remove the speaker from the other pairing device then pair the mobile and the speaker again
- Make sure you have connected the two devices

3. After Installing the USB Bluetooth adapter on the PC , the PC still can not connect with the speaker

- Make sure your Bluetooth adapter is functioning properly .
- On the PC , right-click on the Bluetooth icon and select the option to add a new connection or device , which will make the computer search for available Bluetooth devices .

- Make sure your use " Bluetooth AV audio" instead of " Realtek HD audio output" on your PC
- Restart your PC and search for connections again
- Turn your Bluetooth speaker off and back on

4. Audio is intermittent after establishing a Bluetooth connection

- Make sure your music file is not of poor quality
- Please make sure there is no barrier between the two devices, e.g. Metal objects , walls and other obstacles .
- Move your Bluetooth device and /or Gsou U220 speaker from any device that generates electromagnetic interference, such as another Bluetooth device, cordless phone, microwave oven or wireless router.

* Kindly Reminder

1. In order to save electricity and protect the environment, the loudspeaker supports Intelligent sleep mode when the power is on. If the speaker still has not connected automatically within 15 minutes , please restart your speaker .
2. Compatibility: This speaker is compatible with most major brands and models of Bluetooth mobile phones. However, there may be a few individual Bluetooth mobile phones with which it is not compatible. If you experience any compatibility issues with this speaker, please call our customer service hotline for help.

10. Limited Warranty

Your Gsou U220 Bluetooth® speaker is covered by a limited warranty. It is backed by 1 year performance warranty against any manufacturing defects in material or workmanship from the date of original purchase. This warranty entitles the purchaser to get the product repaired or replaced under the following conditions:

- **The warranty applies to the original purchaser, Proof of original purchase is required**
- **The warranty does not cover the damage caused by misuse, abuse or improper storage.**
- **In no event shall Gsou be responsible for any direct, incidental, consequential or other damages of any kind.**

11. Statement

The Gsou trademark and logo are registered trademarks of Gsou Technology (Shenzhen)Co.,Ltd. All Rights Reserved. All other trademarks, logos or service marks are the property of their respective owners.

Contact Us

Gsou Technology (Shenzhen)Co.,LTD
 Add:14c, Block A, First World plaza, No.7002 West Hongli Road, Futian District, Shenzhen, China.
 Tel: 0086-755-8326 6570 Fax:0086-755-8325 5400
 E-mail: sales@gsou.cn
 Website: www.gsoutech.com