

MIDI SYSTEM CONTROL

Fx-25 MKII



MANUAL



CONTENTS :

Foreword

Warranty

Functions - p.5

1 - Front Panel - p.6

1.1- Button functions in user mode - p.7

1.2- Button functions in PROGRAM mode (2nd) - p.8

2 - Rear Panel - p.9

3 - MIDI connection- p.10

4 - Important Notes - p.11

5 - Menu Fx-25 BLOCK DIAGRAM- p.12

6 - INITIAL START - p.13

7 - MIDI MENU - str.14

7.1 - assigning midi cc commands to s1-s12 (s13-s27) pedal 1, pedal 2 - p.15

7.2 - menu switch s1-s12 (s13-s27) - p.17

7.3 - menu pedal 1 / pedal 2 - p.18

8 - SYSTEM MENU - p.19

8.1 - Expression pedal calibration - p.20

8.2 - Expanders - p.22

8.3 - Firmware Version- p.23

8.4 - TAP TEMPO button activation- p.24

8.5 - Quick Program button activation S1-S12 - p.25

8.6 - PRESET NAMES activation - p.26

9 - EDIT SONG & PRESET MENU - str.28

9.1 - BANK NAME edit - p.28

9.2 - BANK PRESET edit - p.30

9.3 - Program Change command edit for given PRESETS - p.33

9.4 - Direct Access button configuration for given PRESETS - p.35

9.5 - Virtual expression pedal configuration for given PRESETS - p.37

9.6 - Real expression pedal configuration for given PRESETS - p.39

10 - SET SONG MENU - str.41

10.1 - SET LIST choice - p.41

11 - COPY - p.42

11.1 - Copy Bank - p.42

11.2 - Copy Bank - p.43

12 - CABLES - p.44

13 - Installation drivers USB FX-25 - p.45

14 - Fx-25 Programmer - p.54

15 - Update Firmware - p.58

Foreword

Congratulations on buying your midi controller model: Fx-25. Before you, lies the most advanced MIDI controller available on the market, able to communicate with almost every MIDI system and allowing you to program 384 effects options (64 BANK/ SONG x 6 PRESET) to a system which it has been connected to.

The controller communicates through CC commands (control change) and PC (program change) over 16 different polyphonic channels.

Your controller has been modified to the maximum extent, through innovative electronic solutions and usability design features, resulting in a comfortable and responsive feel. Additionally the controller can be instantly programmed by an included USB cable.

Please use Your device according to the technical specifications and our operation suggestions.

THANK YOU FOR READING THROUGH THIS INSTRUCTION MANUAL

BEST WISHES

**MARK L Custom Guitar Electronics
Ul.Stokrotki 12
80-732
Gdańsk
POLSKA
Tel . 506150803
WEB : www.marklcustom.com
Email : info@marklcustom.com**

WARRANTY TERMS AND CONDITIONS

1. The Warranty is limited to production defects and/or faulty components.
2. The Warranty expires 24 months after the date of purchase.
3. The Warranty does not cover the following:
 - Defects caused by shipping and handling.
 - Defects caused by improper usage, product abuse, product neglect, usage not according to the manual or safety precautions.
 - Mechanical damage and defects caused by the former.
 - Defects and malfunctions caused by fire, flood, lightning strike or any other natural disaster, acts of war or social turbulence, corrosion, rust, staining, short circuits, wrong Voltage, wear or any other 'outside' element.
 - Service, improvements or modifications performed by someone other than the Manufacturer of the device.
4. In cases not regulated by the above Warranty Terms and Conditions, appropriate Civil Code regulations apply.

MARK L Custom Guitar Electronics

FUNCTIONS

- **Send PC (Program Change) & CC (Control Change),**
- **64 banks/songs, each one containing 6 presets or 9 presets with expander**
- **6 preset switches (blue LED) 9 preset with expander,**
- **One PRESET can send 74 midi commands**
(2 x 27 CC, 16 PC, 2 exp. pedals, 2 virtual exp. pedals)
- **27 direct access switches (momentary or latch) for CC commands** (12 on foot & 15 virtual or 27 with expander 1st & expander 2nd),
- **Every direct access switch can send 2 midi CC on 2 different channels**
(1-16)
- **Quick SAVE button** (press and hold 2nd to store your settings),
- **Two (global and per preset) expression pedal port,**
- **Two (per preset) virtual expression pedal,**
- **Bank UP& DOWN switches - scroll through banks/songs without activating presets,**
- **Direct access switches assignable up to 7 groups**
- **7 set lists,**
- **Heavy-duty stomp switches, CARLING TYPE**
- **Expression pedal port calibration,**
- **Expander port (expander 1st & expander 2nd),**
- **Software upgrades & editing software for your PC/Mac via USB2.0,**
- **Easy copying presets, banks/songs, set lists,**
- **Easy naming presets/songs, set lists, midi channels, direct access switches and more,**
- **Individual configuration for direct access switches to operate as latching type or momentary type,**
- **TAP TEMPO MODE for switch (S5, S6, S11, S12) momentary or latch – preset change won't mess up in your tempo stored in effect processors,**
- **Sends 127 Midi Program Change Commands on 16 separate user defined Midi channels,**
- **Standard (5-pin) MIDI IN and MIDI OUT jack,**
- **Heavy-duty RACK LINK connection (midi out & power),**
- **Powered by 9-12VAC/800mA adapter ,**
- **External power OUT 9VDC/200mA for WAH and Tuner,**
- **Aluminum enclosure,**
- **Size: W630 mm x D285mm x H85mm x L 40mm**

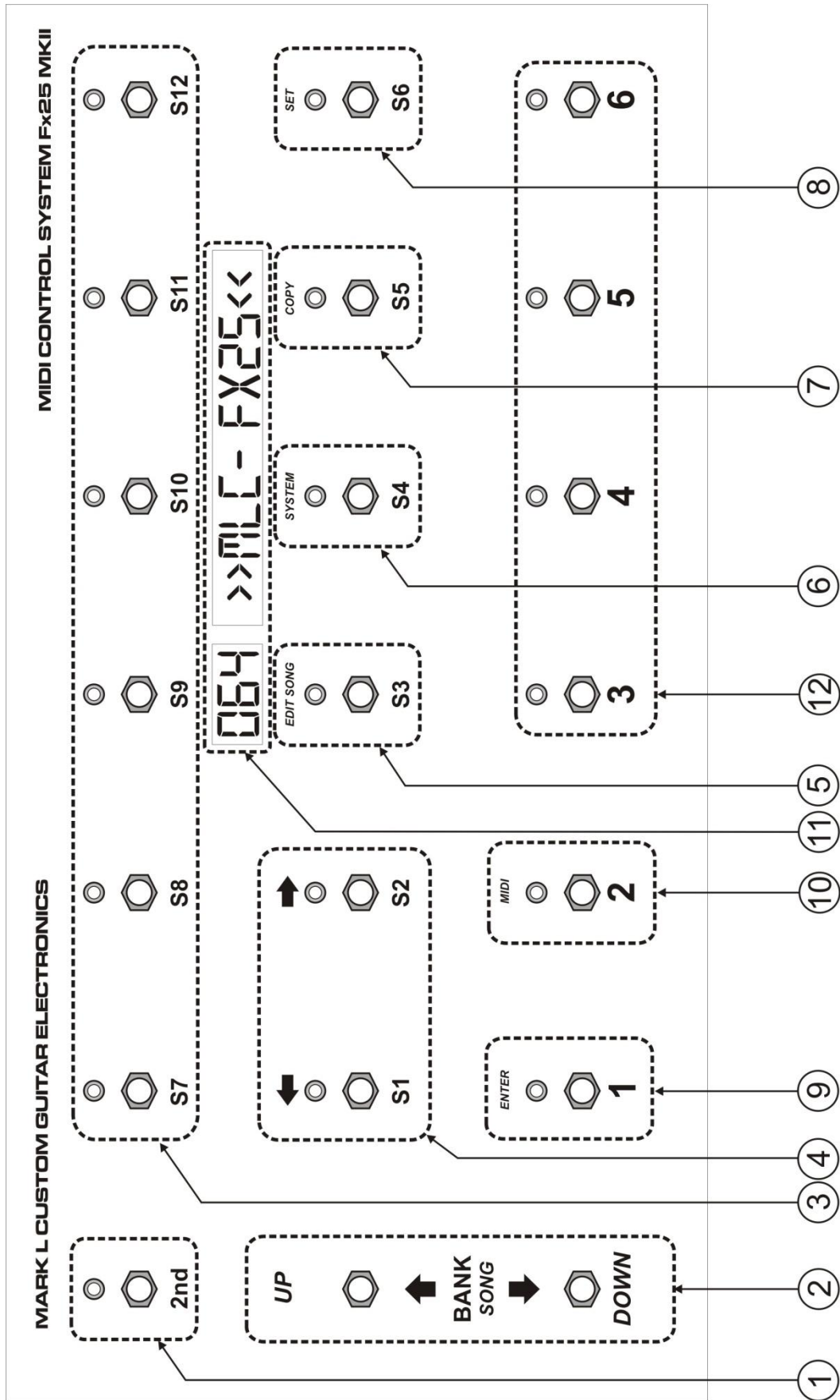

Front Panel

Numbers in brackets correspond to numbers on page 6.

2nd/SAVE(1) switch :

- This switch changes functions of all buttons found on the controller which have an additional description located above. These options are for Function Edit.
- **2nd** button activates Edit mode, a blue light above signals its readiness
- Disabling of this feature will move the controller into standard mode, as in of sending previously programmed commands directly to our system
- By pressing and holding the button for 3-4 seconds, configuration **Quick Save** of Direct Access buttons (S1-S12/S1-S27) will take place. This action is signaled by an intermittent blue light above the 2nd button.

1.1- Button functions in user mode:

2nd/SAVE (1)

- **1**(9)- preset nr.1 call up
- **2**(9)- preset nr.2 call up
- **3**(10)- preset nr.3 call up
- **4**(10)- preset nr.4 call up
- **5**(10)- preset nr.5 call up
- **6**(10)- preset nr.6S call up
- **S1-S2**(4),**S3**(5),**S4**(6),**S5**(7),**S6**(8),**S7-S12**(3) –
Direct Access buttons used for sending previously programmed MIDI Control Change (CC) commands

Arrow Up „↑” and Arrow Down „↓” **BANK / SONG** (2)

These buttons are used when switching over between BANK numbers and SONG titles.

An UP/DOWN long press allows for quick access to a distant BANKS (Scroll)

1.2- Button functions In Edit mode (2nd)

- LEFT arrow „←”(BACK) and RIGHT arrow „→”S2(4)
used for left/right navigation on the 15-digit LED display or for function Accept/Change
- **EDIT SONG S3(5)**
Enters Preset/Song Edit mode
- **SYSTEM S4(6)**
Enters SYSTEM menu
- **COPY S5(7)**
Enters Copy mode
- **SET S6(8)**
Enters SET menu
- **ENTER 1(9)**
Used for accepting changes, moving through the MENU etc..
MIDI 2(9)
Enters MIDI menu
- Arrow UP „↑” and arrow down „↓” BANK/SONG (2)

The functions of these buttons are used for switching over between bank numbers, song titles, preset numbers, editing command numbers and function changes.
An UP/DOWN button long press, allows for quick access to distant functions (Scroll)

- **DISPLAY(11)**

The controller is equipped with an alphanumeric 15 digit display showing:
Bank Numbers, Song Titles, Preset Names; In program mode: midi command numbers, button function numbers and system status

Rear Panel

Factory no up : 00402011

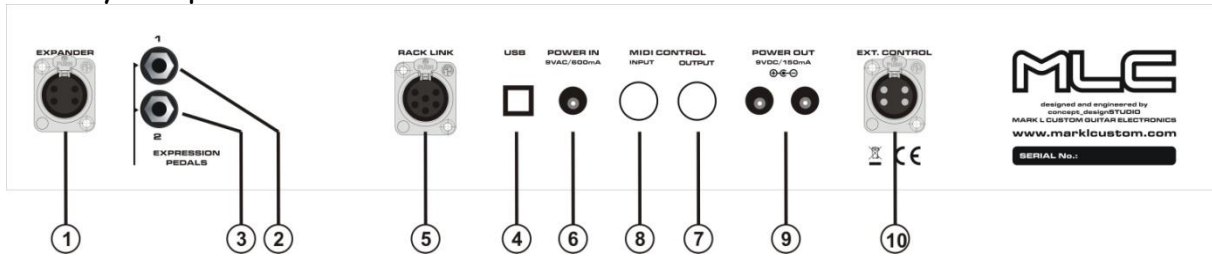

1 - EXPANDER XLR OUT used for plugging in additional expanders (EXPANDER 1st and 2nd)

PIN 1 : 5VDC +
PIN 2 : 5VDC -
PIN 3 : DATA + (13)
PIN 4 : DATA - (17)

2 - P1 standard ¼" stereo jack used for plugging in an external **expression pedal**
Tip - pedal input **Ring** - pedal output **Sleeve** - ground

3 - P2 standard ¼" stereo jack used for plugging in an external **expression pedal**
Tip - pedal input **Ring** - pedal output **Sleeve** - ground

4 - USB connector used for PC/MIDI communication with the FX-25 system

5 - RACK LINK XLR connector used for SYSTEM INTERFACE communication

For more information please contact Mark L Custom

Pin insertion :

PIN 1 : in 9VAC or 12VAC/ min800mA for power FX-25

PIN 2 : in 9VAC or 12VAC/ min800mA for power FX-25

PIN 5 : MIDI OUT +

PIN 4 : MIDI OUT -

PIN 3 : in 12VAC/200mA for converter 9VDC power OUT

PIN 6 : in 12VAC/200mA for converter 9VDC power OUT

6 - POWER IN 2,5mm x 5,5mm Power supply, 9VAC or 12VAC/800mA

7 - MIDI OUT 5-pin standard size MIDI DIN connector, used for communication and exterior power supply of our FX-25 from any MIDI system. A comfortable way of supplying the system with power through pins 1 and 2

8 - MIDI IN

9 - 9VDC POWER OUT standard power 9VDC (max 200mA) for WAH and TUNER (powered via RACK LINK pin 3 and 6)

10 - EXTERNAL CONTROL

MIDI Connection

All exterior MIDI devices can be connected to the Fx-25 MIDI OUT via a standard MIDI DIN 5 cable. If a system uses countless MIDI devices, they can also be connected serially by a MIDI THRU receptacle.

The cable linking the controller and the first device cannot be longer than 15 meters, otherwise delays or signal distortions may be encountered. If need be, cables exceeding 15 meters in length may be used together with a MIDI THRU BOX.

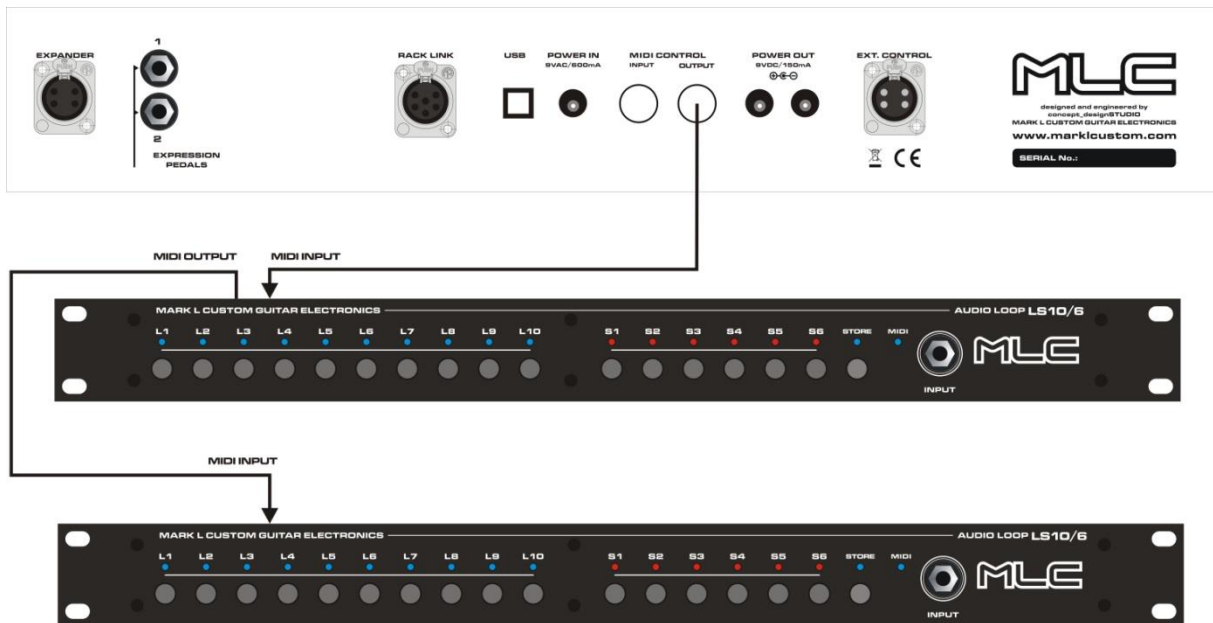

4- Important notes

The Fx-25 controller operates in a **BANK/SONG** mode, meaning 64 banks represent 64 songs. To each song 6 presets – or 6 different settings – are assigned for every device paired to the system.

PRESET

Each given preset can send up to 16 PC (Program Change) commands, 27 CC (Control Change) commands, 4 expression pedals (2 virtual and 2 real) over 16 MIDI channels simultaneously.

BANK

UP/DOWN buttons are used for changing **BANKS** while pressing the **PRESET** buttons (1-6) stores all preprogrammed configurations.

S1-S12 DIRECT ACCESS SWITCH

S1-S12 buttons send MIDI CC commands. They operate as **DIRECT ACCESS** to effects or functions without interfering with **PRESET** setting, thus, any given effect or function can be easily switched on or off.

In order for the S1-S12 buttons to send MIDI CC commands they must be preprogrammed to do so. (see **MIDI MENU**)

QUICK SAVE of DIRECT ACCESS S1-S12 buttons

For every **PRESET 1-6** a various button configuration **S1-S12** can be assigned. Choose a **PRESET** and select any given **DIRECT ACCESS S1-S12** button configuration. To select, press and hold the **2nd** button for 3-4 seconds. After successful configuration save, the **BLUE LED** indicator will flash above **2nd**.

5- Menu FX-25

Short Block Diagram

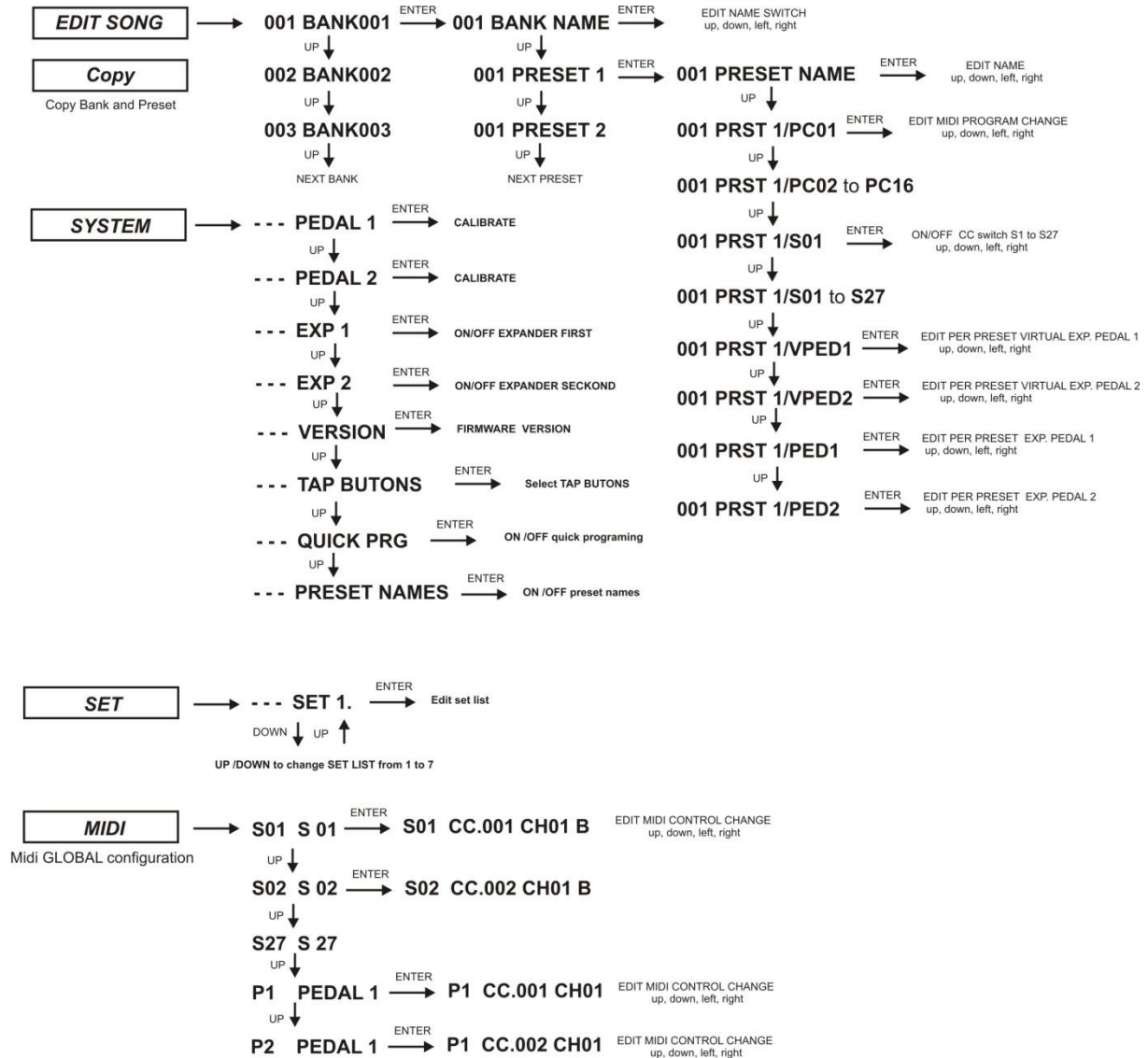

6- INITIAL START

1. Connect the controller and the system or device You wish to control by a MIDI cable to MIDI OUT.
2. If expression pedals are to be used, connect them BEFORE powering up the device.
3. Supply the device with 9VAC power.
4. After powering up, the display will read START TEXT.



After 5 seconds, the controller will move into standard operation mode and will wait for a bank or preset choice (this is indicated by a flashing BANK number)

5. Program Control Change (CC) commands for your pedals and devices (see **MIDI EDIT**)
6. Set and calibrate the expression pedals (see **SYSTEM**)
7. Program PC (Program Change) commands You wish to send (see **SONG EDIT**)
8. Change BANK names and PRESET names (see **SONG EDIT**)

YOUR FX-25 CONTROLLER IS READY TO WORK

7-MIDI Menu

For the controller to send appropriate MIDI CC commands, You should **GLOBALLY** assign them to **S1-S12 (S13-S27)** buttons and to expression pedals. They will be the main **GLOBAL** settings.

Each button (S1-S27) sends 128 MIDI CC commands (0-127) over 16 channels, so with the help of our controller we can send 2x12 (27) previously assigned commands over various channels. MIDI CC commands in guitar systems are usually used to turn on or off any number of devices as well as for expression pedals and functions such as **TAP TEMPO**

The FX-25 sends **128 MIDI CC** commands (**0-127**) over 16 channels. Thanks to this controller **12 (27)** previously assigned commands can be sent over different channels. In guitar systems MIDI CC commands are usually used for turning on or off of our devices in the system as well as for expression pedal operation and **TAP TEMPO**.

S01	S 01 # CC1
S01	S 01 # CC2
S02	S 01 # CC1
S02	S 01 # CC2
P1	PEDAL 1
P2	PEDAL 2

CC button choice:

Each of the **S-1-S27** buttons can send 2 different MIDI CC commands over 2 MIDI channel. The first main MIDI command of each button (S1-S27) is CC1. Select S01 # CC1 and define the first number of the command (0-127), MIDI channel (1-16) and the basic function of the button, namely whether it has to be **STABLE (LATCH)** or temporary (**MOM**) and to which group of buttons does it have to belong (1-7)

7.1 ASSIGNING MIDI CC COMMANDS TO S1-S12 (S13-S27) PEDAL 1, PEDAL 2

- Enter Edit mode by holding the **2nd** button
- The display will read **MENU**



- 2nd is a function which reverses the meanings of the buttons on the controller

so:

PRESET 1 is now **ENTER**

PRESET 2 is now **MIDI** menu

S1 is now a **LEFT** cursor (**BACK**)

S2 is now a **RIGHT** cursor

S3 is **EDIT SONG/BANK**

S4 is **SYSTEM**

S5 is **COPY**

S6 is **SET**

BANK UP & DOWN are **UP/DOWN** cursors

Choose a button or expression pedal which You wish to edit (S1-S12), PEDAL1 – PEDAL2 and press ENTER (preset 1) The display should read the button or expression pedal menu.

- Enter the MIDI MENU by pressing **MIDI button** ‘ (preset 2)
- The display will read MENU Control Change for 1 of 12 Direct Access buttons.



UP/DOWN buttons move between S1 to S12 and PEDAL 1, PEDAL 2.

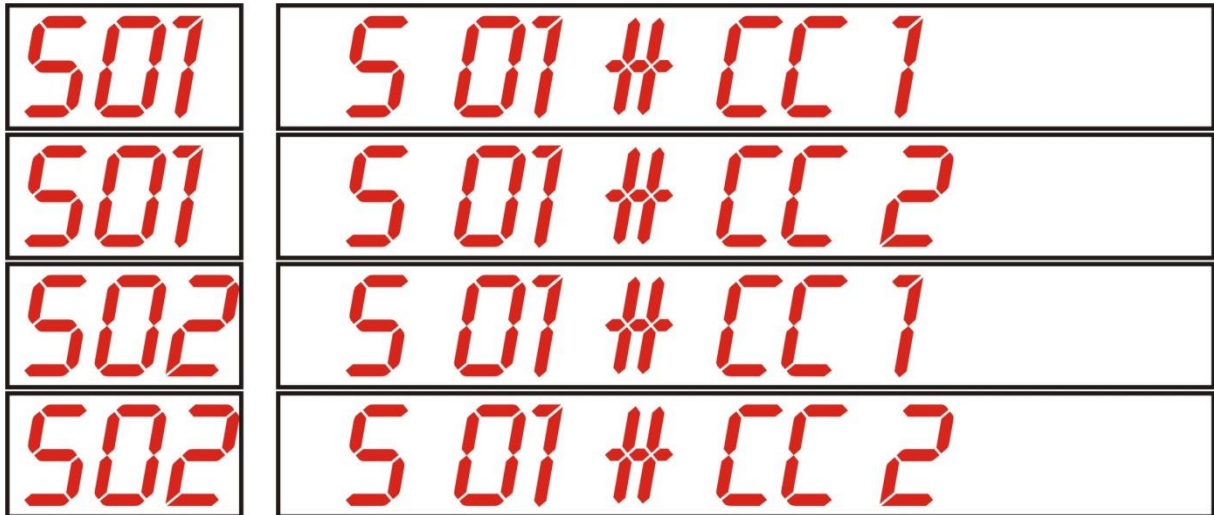

UP/DOWN

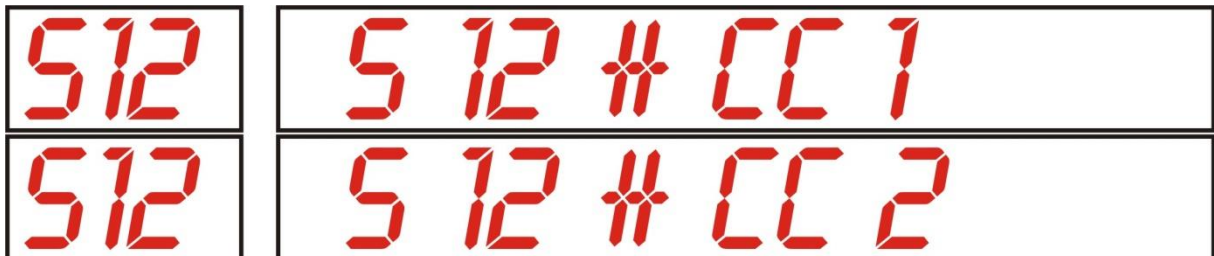

UP/DOWN

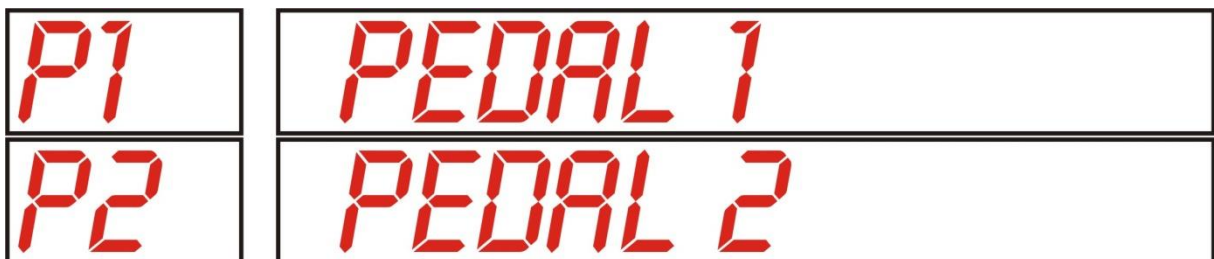

7.2 MENU SWITCH S1-S12 (S13-S27)

Each of the buttons S1-S12 (S13-S27) has an option of sending 2 different MIDI CC commands.

Buttons S01 # CC1 are used to assign the first MAIN CC function as well as the TYPE and GROUP option.

Buttons S01 # CC2 are used to assign only the second CC command.

MENU S01 #CC1:



MENU S01 #CC2:



If there is no need for sending two different MIDI commands, select OFF in the #CC2 menu.

- S01** - button nr.1
- CC.011** - command number MIDI CC 11
- CH01** - channel number MIDI CH 01
- >>** - next page
- <<** - previous page
- LATCH** - button type LATCH (stable) MOM (temporary)
- GRP--** - group number - - (off) or (1-7)

By moving left (S1), right (S2) you will move the cursor (DOT on the screen) between:

- CC Control Change command
- button type
- group

7.3 MENU PEDAL 1 / PEDAL 2

The Fx-25 can globally assign 2 different expression pedal parameters



Expression pedals available on the market:

LINE- standard expression pedal

LOGARITHMIC-standard volume pedal

Due to the fact that they have various operating characteristics, in the FX-25 you may choose any available expression pedal type.

By pressing UP/DOWN you may choose the needed expression pedal type.

TYPE LIN – LINE PEDAL

TYPE LOG – LOGARITHMIC PEDAL

TYPE SWITCH – EXTERNAL SWITCH F.E., TAP TEMPO

In this way we have assigned All MIDI CC commands for our quick-access buttons (s1-S12) and expression pedals (PEDAL1,PEDAL2)

IN ORDER TO EXIT EDIT MODE PRESS 2ND BUTTON. Now the controller is ready to send Control Change commands.

8-SYSTEM Menu

In the SYSTEM menu the following functions are available:

- Expression PEDAL 1 and 2 calibration
- Additional expanders (real and virtual) EXP1, EXP2
- Firmware VERSION
- Tap Tempo for each TAP BUTTON
- QUICK PRG on/off for quick programming
- PRESET NAMES on/off

SYSTEM MENU

- - -	PEDAL 1
- - -	PEDAL 2
- - -	EXP 1
- - -	EXP 2
- - -	VERSION
- - -	TAP BUTONS
- - -	PRESET NAMES

8.1 expression pedal calibration

Resistance for expression pedals – 50kOhm to 500kOhm

- **With the device turned off, plug the expression pedals in to ports P1-P2 also please check cable connection for your pedal (page 44)**
- **Power up the device**
- By pressing the **2nd** button, enter EDIT mode
- The display will read **MENU**



- 2nd is a function reversing the meaning of the buttons found on the controller

so:

PRESET 1 is now **ENTER**

PRESET 2 is now **MIDI** menu

S1 is now a left cursor **LEFT (BACK)**

S2 is now a right cursor **RIGHT**

S3 is **EDIT SONG/BANK**

S4 is **SYSTEM**

S5 is **COPY**

S6 is **SET**

BANK UP & DOWN is cursor **UP / DOWN**

(**PEDAL 1 > PEDAL 2 > EXP 1 > EXP 2 > VERSION > TAP BUTONS > QUICK PRG > PRESET NAMES**)

- Enter the **SYSTEM MENU** by pressing **SYSTEM (S4)** button, the display will read **PEDAL1**, 1 of 2 expression pedals



By pressing **ENTER MENU**, **PEDAL 1** will be activated

- Now, the device will move into the calibration menu



- Press **ENTER** (preset 1)



- Set the lower position on the expression pedal and press **ENTER** (Preset 1)
- Next, by pressing **UP** move to the maximum expression pedal setting and press **ENTER** (preset1). Set the expression pedal to the highest setting.
The display will read the number 4000 (The last digit is subject to change)



- press **ENTER (PRESET 1)** to confirm
- Next, by pressing **UP** move to expression pedal **TEST** and confirm by pressing **ENTER** (Preset 1)



- The display will now read **TEST**. To check whether CC VALUE commands (0-127) change fluidly, move the pedal through its lowest and highest positions.

-Confirm by pressing **ENTER** (Preset 1) and then press **LEFT (BACK)** button to move back into the **SYSTEM MENU**

IN ORDER TO CALIBRATE PEDAL 2, FOLLOW THE ABOVE MENTIONED STEPS ACCORDINGLY.

8.2 EXPANDERS

REAL EXPANDERS

The controller can be expanded by 3 presets (7-9) and 15 additional DIRECT ACCESS buttons (S13-S27).

In order to do so, the FC25 must be equipped with 1 or 2 additional auxiliary expanders:

EXPANDER 1st – 3 presets and 6 Direct Access buttons

EXPANDER 2nd – 9 Direct Access buttons

Of course FX25 can use with 1st expander or 2nd expander or both expanders.

VIRTUAL EXPANDERS

The controller may also operate without auxiliary real expanders, the functions of buttons S13 – S27 are then available through the MIDI menu and may be activated through EDIT BANK/SONG or by a computer program.

Additional preset functions are in this case unavailable.

ADDITIONAL EXPANDER ACTIVATION

- By pressing **2nd** enter the **EDIT** mode
- The display will now read **MENU**

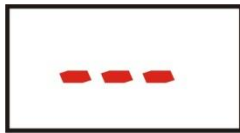

- Enter the SYSTEM MENU by pressing the **SYSTEM (S4)** button, the display will now read **PEDAL1**.
- By pressing **UP**, move to **EXP1** menu box.



- press **ENTER** to confirm (Preset1)
- The display will read that expander 1 is turned off



- In order to activate expression pedal 1, press **UP/DOWN**. The display will read **ON**.

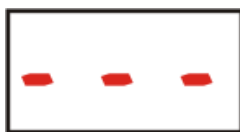

- Now we have successfully activated 3 additional presets and 6 DIRECT ACCESS BUTTONS S13-S18

In order to activate EXP2 follow the abovementioned instructions.

8.3 FIRMWARE VERSION

The Fx-25 has been equipped with a USB port , used for communicating with a PC . Thanks to this, the firmware on the controller can be updated to a newer version available on www.marklcustom.com

To check your firmware version:

- Enter EDIT mode by pressing **2nd**
- The display will read **MENU**



- Enter SYSTEM MENU by pressing **SYSTEM (S4)**. The display will read **PEDAL1**
- By pressing **UP** move into **VERSION**.



- Confirm by pressing **ENTER (Preset1)**



- The display will now read the current firmware version
- By pressing **LEFT (BACK)** move into main **SYSTEM** menu

8.4 TAP TEMPO BUTTON ACTIVATION

We can choose from 1 of 4 buttons (S5,S6,S11,S12) to control TAP-TEMPO.

If TAP-TEMPO will be used, it should be chosen in the TAP BUTTONS menu as 1 of 4 buttons.

This function allows for the omission of the buttons used for TAP TEMPO while changing PRESETS. If this option is not selected, while using TAP TEMPO, changing of any presets will result in the change in tempo, thus changing the timing we want to achieve.

To set the TAP BUTTONS on the controller:

- Enter EDIT mode by pressing 2nd.
- The display will read **MENU**



- By pressing **SYSTEM (S4)** enter the SYSTEM MENU, the display will read PEDAL 1
- By pressing **UP** move into **TAP BUTTONS** menu.



Confirm by pressing **ENTER** (Preset1)



- By pressing **UP**, choose which of the buttons (S5,S6,S11,S12) shall be **TAP TEMPO**
- Confirm by pressing **ENTER** (Preset1)
- The display will read that **TAPS5** is turned **OFF**



- To activate, press **UP/DOWN** to change its status to **ON**.



- By pressing **LEFT** (**BACK**) twice, move into main system **MENU**

To activate other S buttons, follow the abovementioned instructions

8.5 DIRECT ACCESS BUTTON Quick PRG ACTIVATION S1-S12

- The QUICK PRG function is by default turned on.

- Enter EDIT mode by pressing **2nd**
- The display will read **MENU**



- Enter **SYSTEM MENU** by pressing **SYSTEM S4** button, the display will read **PEDAL 1**
- By pressing **UP** move into **QUICK PRG**



- confirm by pressing **ENTER** (preset 1)



- Because this function is by default turned on, to turn it off change its status to **OFF** by pressing the **UP/DOWN** button.



- By pressing **LEFT (BACK)** move into main **SYSTEM MENU**

8.6 PRESET NAMES ACTIVATION

PRESET NAMES function allows us not only to assign **BANK/SONG** names but also to name **PRESETS** . In standard user operation mode select **UP/DOWN** to choose the appropriate **BANK/SONG**, then activate the given preset 1-6. After this the display will read the **BANK** number and the previously assigned preset name.

Turn the controller into standard operating mode. Choose **UP/DOWN** and a given bank number (1-64) fe. **BANK.SONG 2**



-Then, activate any preset (1-6), Fe. **PRESET 3**



- The display will read: Active **BANK 002** and **PRESET 3**

PRESET NAMES function is by default turned **ON**

- Enter **EDIT** mode by pressing **2nd**
- The display will now read **MENU**



- Enter **SYSTEM MENU** by pressing **SYSTEM (S4)**, the display will now read **PEDAL 1** na wyświetlaczu pojawia sie **PEDAL 1**,
- By pressing **UP** move to **PRESET NAMES** menu.



- confirm by pressing **ENTER** (preset 1)



- Because this function is by default turned ON, to deactivate press **UP/DOWN** to change the status to **OFF**.



- By pressing **LEFT (BACK)** move into main **SYSTEM MENU**

9-EDIT SONG & PRESET Menu

IN EDIT SONG the following functions are available:

- BANK NAME
- PRESET NAME
- MIDI Program Change EDIT for given presets
- MIDI Control Change EDIT for expression pedals assigned to given presets

Here, all **NAMES OF BANKS/SONGS** (1-64) and **PRESETS** (1-6) can be edited as well as **PROGRAM CHANGE (PC)** commands assigned to our processors and devices and **CONTROL CHANGE** preset (1-6) commands for real **PEDAL1**, **PEDAL2** and virtual **VPED1**, **VPED2** expression pedals.

9.1 BANK NAMES EDITING

The Fx-25 has 64 BANK/SONG built in, functioning both as a song and as a bank.

Each bank (1-64) can be described using the 15 digit LED display to make navigation much cleaner and easier. Therefore, it can easily be seen what lies under a given bank.

- enter EDIT mode by pressing **2nd**
- The display will read **MENU**



- 2nd is a function which reverses the meanings of the buttons on the controller
so:

- PRESET 1** is now **ENTER**
- PRESET 2** is now **MIDI** menu
- S1** is now **LEFT** cursor (**BACK**)
- S2** is now **PRAWO** cursor
- S3** is **EDIT SONG/BANK**
- S4** is **SYSTEM**
- S5** is **COPY**
- S6** is **SET**
- BANK UP & DOWN** is now **UP/DOWN** cursor

(BANK 001-064), (BANK NAME >PRESET 1-6), (PRST 1 / NAME > PC01-16 > S1-12 > VPED1>VPED2 > PED1> PED2)

- Enter **EDIT SONG** menu by selecting **EDIT SONG** (S3), the display will now read **BANK 001**.



- By pressing **UP/DOWN** we move through banks 001-064 which we want to edit.
- Confirm by pressing **ENTER** (PRESET1)



- Now we are in the bank name and PRESET EDIT MENU. If editing a bank name confirm by pressing **ENTER** (Preset1)



- Now we find ourselves in the BANK NAME Edit menu. To edit use:
S1 is LEFT (BACK) cursor
S2 is RIGHT

The cursor is a dot at the bottom of each sign.

BANK UP/DOWN is the **UP/DOWN** cursor, **used for selecting the appropriate letter, number or sign.**

In order to Edit a Word, by using the cursor (dot) choose and appropriate sign on the LED display.

- Confirm by pressing **ENTER** (preset1) or by **LEFT** (BACK) button we move into **BANK NAME** and **PRESET EDIT MENU**

9.2 BANK & PRESET EDIT

Each bank has **6 presets** assigned, under which the following functions are present:

-Program Change commands **1-6**

ON/OFF buttons **S1-S12**

Control Change commands for virtual expression pedals **VPED1, VPED2**

Control Change commands for real expression pedals **PED1, PED2**

PRESET EDIT MENU in a given BANK



UP/DOWN



ENTER



UP/DOWN



UP/DOWN



- Enter EDIT mode by Pressing **2nd**
- The display will read **MENU**



- Enter **EDIT SONG MENU** by pressing **EDIT SONG (S3)** button
- The display will read **BANK 001**



- By pressing **UP/DOWN** we move through banks 001-064 in which **PRESETS** we want to edit

- confirm by pressing **ENTER** (preset 1)



- By pressing **UP/DOWN** move to **PRESET 1-6** menu. Fe. **PRESET 3**



- Confirm by pressing **ENTER** (preset 1)



- We are now in the **PRESET** name menu, if we wish to edit the name confirm by pressing **ENTER** (Preset1) and follow the instructions for **BANK EDIT** on p. 29 and 30
- By pressing **UP/DOWN** we move to the main **PRESET** menu

PRESET 3 MAIN MENU (scroll UP/DOWN)

001	PRST3 / NAME
-----	--------------

001	PRST3 / PC01
-----	--------------

001	PRST3 / PC16
-----	--------------

001	PRST3 / S01
-----	-------------

001	PRST3 / S27
-----	-------------

001	PRST3 / VPED01
-----	----------------

001	PRST3 / VPED02
-----	----------------

001	PRST3 / PED 1
-----	---------------

001	PRST3 / PED 2
-----	---------------

9.3 Program Change commands EDIT for given PRESETS

Each **PRESET** 1-6 can send 16 different Program Change commands over 16 different MIDI channels

In order to assign 1 from 16 PC commands for a 9 PRESET:

- Enter EDIT mode by pressing **2nd**
- The display will read **MENU**



- Enter **EDIT SONG MENU** by pressing **EDIT SONG (S3)** button, the display will now read **BANK 001**



- By pressing **UP/DOWN** we move through banks 001-064, in which we want to **EDIT PRESETS**.
- Confirm by pressing **ENTER** (Preset1)



- By pressing **UP/DOWN** move to **PRESET 1-6** menu. Fe. **PRESET3**



- Confirm by pressing **ENTER** (Preset1)



- By pressing **UP/DOWN** move into PC 01-16 MENU



- PRST 1-9/ PC01 to Program Change for MIDI CHANNEL 1
- PRST 1-9/ PC02 to Program Change for MIDI CHANNEL 2
- PRST 1-9/ PC03 to Program Change for MIDI CHANNEL 3
- PRST 1-9/ PC04 to Program Change for MIDI CHANNEL 4
- PRST 1-9/ PC05 to Program Change for MIDI CHANNEL 5
- PRST 1-9/ PC06 to Program Change for MIDI CHANNEL 6
- PRST 1-9/ PC07 to Program Change for MIDI CHANNEL 7
- PRST 1-9/ PC08 to Program Change for MIDI CHANNEL 8
- PRST 1-9/ PC09 to Program Change for MIDI CHANNEL 9
- PRST 1-9/ PC10 to Program Change for MIDI CHANNEL 10
- PRST 1-9/ PC11 to Program Change for MIDI CHANNEL 11
- PRST 1-9/ PC12 to Program Change for MIDI CHANNEL 12
- PRST 1-9/ PC13 to Program Change for MIDI CHANNEL 13
- PRST 1-9/ PC14 to Program Change for MIDI CHANNEL 14
- PRST 1-9/ PC15 to Program Change for MIDI CHANNEL 15
- PRST 1-9/ PC16 to Program Change for MIDI CHANNEL 16

- Confirm by pressing **ENTER** (Preset1)



-PC Program Change commands (UP/DOWN)

-Confirm by pressing **ENTER** (Preset 1)

-MIDI PC command Has been saved

In order to edit next commands, follow the abovementioned instructions.

9.4 S1-S12 button CONFIGURATION for given PRESETS

12 previously programmed DIRECT ACCESS S1-S12 buttons can be assigned to any given PRESET 1-6. (DIRECT ACCESS button configuration p. 16)

The easiest way of saving a given configuration of S1-S12 buttons is by choosing the PRESET 1-6 then choosing the S1-S12 buttons and pressing 2nd button for 3-4 seconds.

Configuration save will be confirmed by a flashing blue LED above the 2nd button

S1-S12 configuration through EDIT MENU

- Enter EDIT mode by pressing 2nd
- The display will read MENU



- Enter EDIT SONG MENU by pressing EDIT SONG (S3), the display will now read BANK 001.



- By pressing UP/DOWN we move through BANKS 001-064 in which we wish to edit PRESETS
- Confirm by pressing ENTER (preset 1)



- By pressing UP/DOWN move to PRESET 1-6 menu fe. PRESET 3



- Confirm be pressing ENTER (preset 1).



- By pressing **UP/DOWN** move to S01 to S12 menu
- confirm by pressing **ENTER** (preset 1).



- Because **S1** is by default turned off, to activate it press **UP/DOWN** changing its status from **OFF** to **ON**.

This is useful mainly when it comes to virtual button activation for given presets. If we do not possess additional expanders we will not be able to QUICK SAVE (see page 36).

9.5 Virtual expression pedal CONFIGURATION for given PRESETS

One interesting feature found on the Fx-25, is the ability to assign each of the presets 1-6 to any virtual expression pedal.
Most often, this function is used to define the appropriate constant volume level of a chosen processor due to the fact that virtual pedals send control change commands between the values of 0-127.

VPED 1, VPED 2 Configuration

- Enter EDIT mode by pressing **2nd**
- The display will read **MENU**



- Enter **EDIT SONG MENU** by pressing the **EDIT SONG (S3)** button, the display will read **BANK 001**.



- By pressing **UP/DOWN** we move through **BANKs 001-064** in which we want to edit **PRESETS**.
- Confirm by pressing **ENTER** (Preset1)



- By pressing **UP/DOWN** move into **PRESET 1-6** menu Fe. Preset 3



- Confirm by pressing **ENTER** (Preset 1)



- By pressing **UP/DOWN** move into S01 to S12 menu
- Confirm by pressing **ENTER** (preset 1)



- Confirm by pressing **ENTER** (preset 1)



- By pressing **UP/DOWN** choose the appropriate CC command. Move the cursor using the **RIGHT (S2)** button to the MIDI channel selection (**UP/DOWN**)



- Next move the cursor to the next 'page' by pressing **RIGHT (S2)**



- By pressing **UP/DOWN** choose the appropriate VALUE (0-127)
- Confirm by pressing **ENTER** (preset 1)
- By pressing 2nd exit **EDIT** mode

9.6 Expression PEDAL1, PEDAL2 configuration for given PRESETS

Another interesting feature on the Fx-25 is the ability to assign any expression pedal to any PRESET 1-6. In this case for each preset, the expression pedal may be used with a different device or function in the system.

If the pedal is not assigned to a given preset, then its settings will be GLOBAL (p. 14)

PED 1, PED 2 CONFIGURATION

- Enter EDIT mode, by pressing **2nd**
- The display will read **MENU**



- Enter EDIT SONG MENU by pressing EDIT SONG (S3), the display will read BANK 001



- By pressing **UP/DOWN** move through BANKS 001-064 in which You want to edit **PRESETS**.
- Confirm by pressing **ENTER** (preset 1)



- By pressing **UP/DOWN** move to **PRESET 1-6** menu fe. **PRESET 3**



- Confirm by pressing **ENTER** (preset 1)



The image shows a digital display with two sections. The left section is a small square box containing the number '001'. The right section is a larger rectangular box containing the text 'PRST 3 / NAME' in a red, seven-segment font.

- By pressing **UP/DOWN** move to PED 1. PED 2 menu.
- Confirm by pressing **ENTER** (preset 1)



The image shows a digital display with two sections. The left section is a small square box containing the number '001'. The right section is a larger rectangular box containing the text 'PRST 3 / PED 1' in a red, seven-segment font.

- Confirm by pressing **ENTER** (preset 1)



The image shows a digital display with two sections. The left section is a small square box containing the number '001'. The right section is a larger rectangular box containing the text 'CC OFF' in a red, seven-segment font.

By pressing **UP/DOWN** select the appropriate CC command by pressing **RIGHT (S2)** and move the cursor to the MIDI CHANNEL choice (UP/DOWN)



The image shows a digital display with two sections. The left section is a small square box containing the number '001'. The right section is a larger rectangular box containing the text 'CC 015 CH01' in a red, seven-segment font.

- Confirm by pressing **ENTER** (preset 1)
- Exit EDIT mode by pressing 2nd.

10-SET LIST Menu

In the SET SONG menu we can edit 8 set lists, meaning we can have 8 different combinations of our songs.

The basic set list SET DEFAULT, is a list of tracks done in the beginning during EDITING SONGS. (EDIT SONG).

Set Default is impossible to edit because these are factory settings. **Set lists 1-7 can be edited by any given song sequence displayed in banks 1-64**

EDIT function is available only from FX25 Programmer

10. SET LIST choice

- Enter EDIT mode by pressing **2nd**
- The display will read **MENU**



- Enter **SET MENU** by pressing **SET (S6)**



- By pressing **UP/DOWN** choose **SET1 – SET7**
- By pressing **2nd** exit the **SET** menu

11 - COPY

The Fx-25 is also equipped with a COPY function. One may COPY whole BANKS as well as chosen PRESETS from given BANKS. So **PRESET 3** from **BANK 34** can be copied to **PRESET 1 BANK 1**

11.1 COPY BANK



- Enter EDIT SONG MENU by pressing EDIT SONG (S3), the display will read BANK 001



-Enter COPY



- By pressing UP/DOWN choose **BANK 001 – BANK 064**

- Confirm by pressing **ENTER** (preset 1)

11.2 COPY PRESET



-Enter EDIT SONG MENU by pressing EDIT SONG (S3), the display will read BANK 001



-Enter BANK



- By pressing **UP/DOWN** choose **PRESET 1 – PRESET 6**

-Enter COPY



↑ ↑ ↑ ↑
Bank no. Preset no. Copy to Copy to
Bank no. Preset no.

- By pressing **UP/DOWN** choose BANK next **PRESET 1 – PRESET 6**

- Confirm by pressing **ENTER** (preset 1)

12-CABLES

If You wish to use expression pedals P1-P2 with the Fx-25, cables you use will be very important. Below is a diagram showing how such as cable must be made.

P1 & P2 is a JACK STEREO 6,5mm

- Tip** - pedal input
- Ring** - pedal output
- Sleeve** - ground

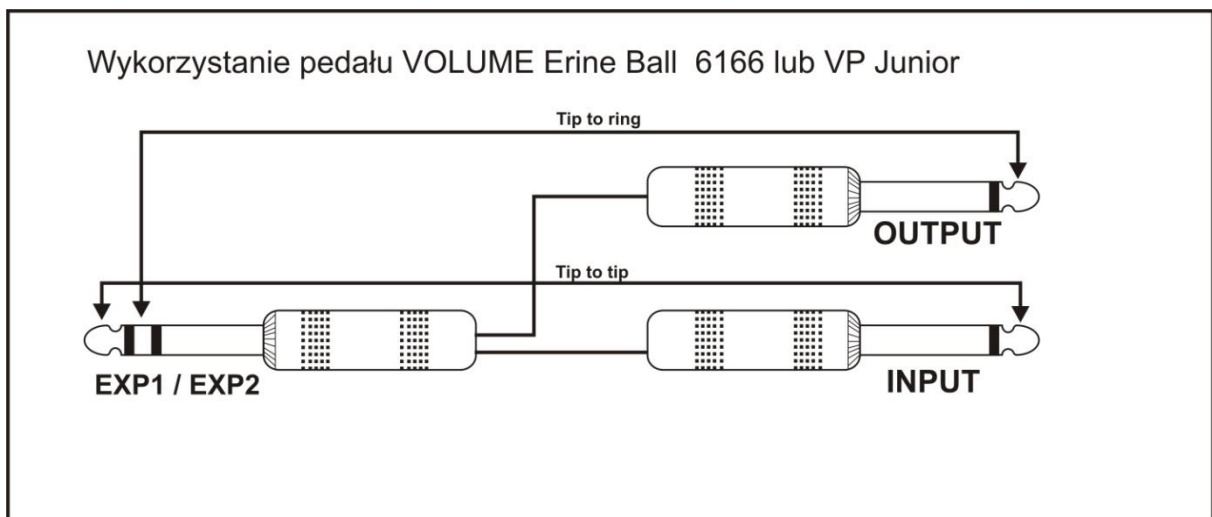

An exterior switch Fe. TAP TEMPO

If You want to use port P1 or P2 for TAP TEMPO, in the CALIBRATION SETTINGS You must change the expression pedal **TYPE** to **SWITCH**

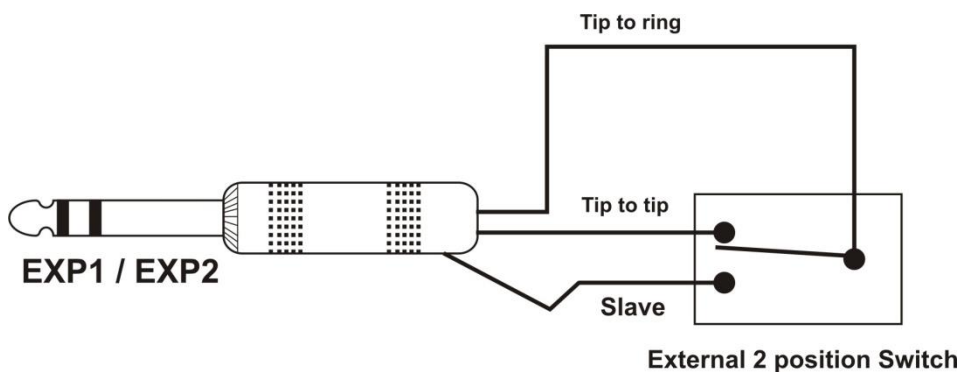

13-Fx-25 USB installation drivers

In order to Edit or update the firmware on the controller, use the included Fx-25 program

Supported operating systems: MAC, WIN XP, VISTA ,WIN 7, WIN 8

To connect the device with the computer:

1. Connect the controller with the included USB cable.
2. A 'New Device Found' window will appear.



3. Later on, proceed with driver installation. Select "not this time" for Windows Update.

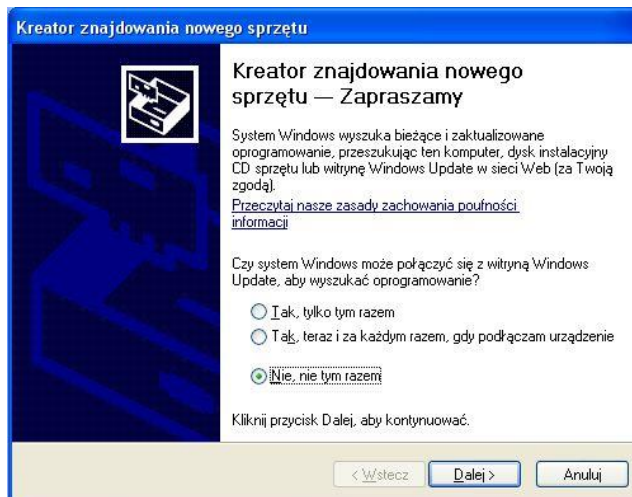

4. Select "Next" (auto install).

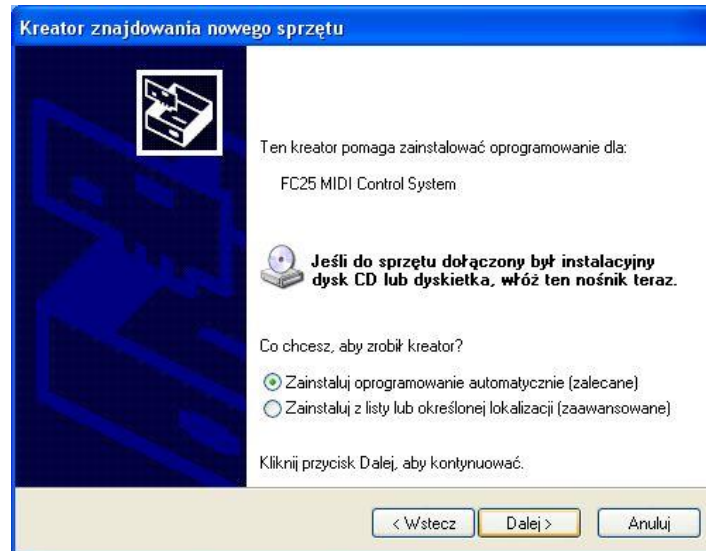

5. Choose "Install from the list of programs" (ADVANCED).

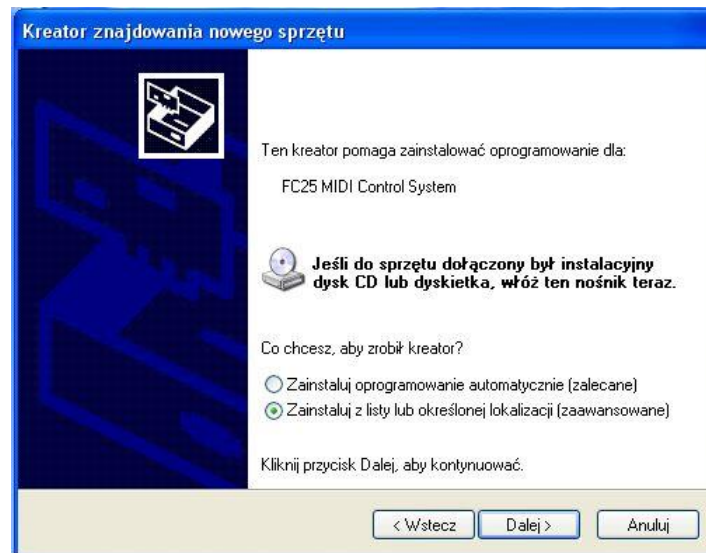

6. Choose “search” and give the location of the driver f.e. cd-rom.

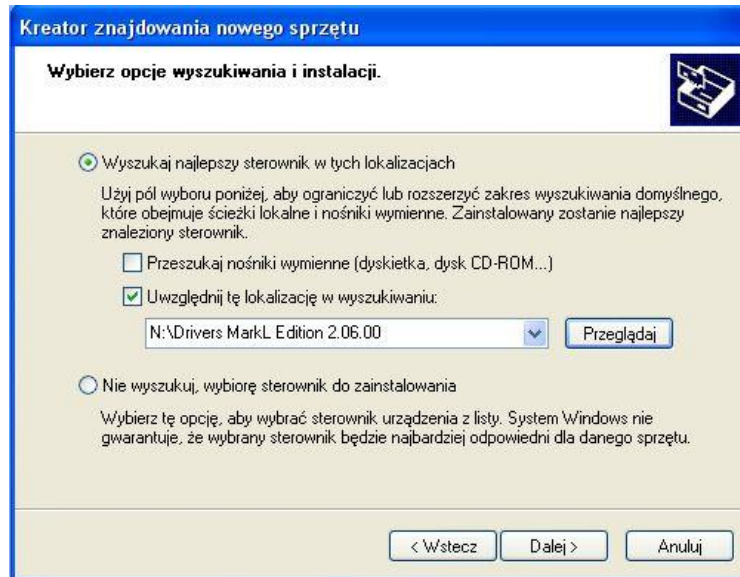

7. The install wizard will now begin searching.

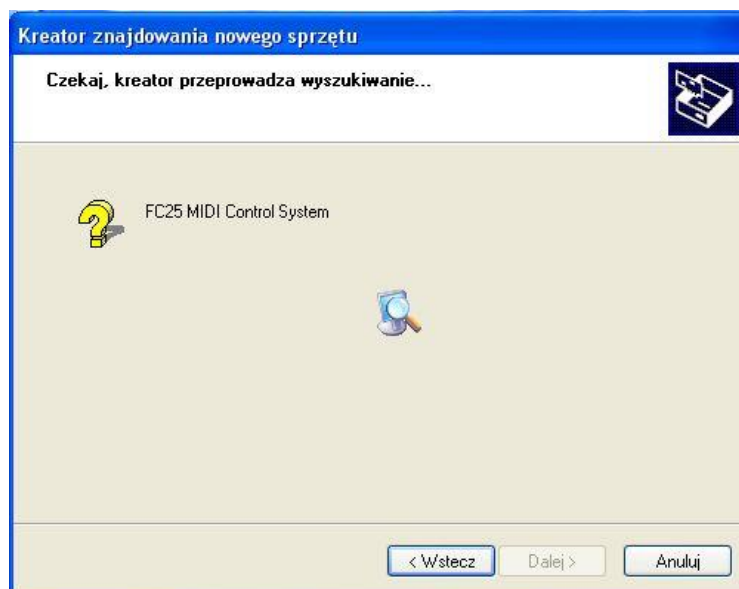

8. Select “Continue”

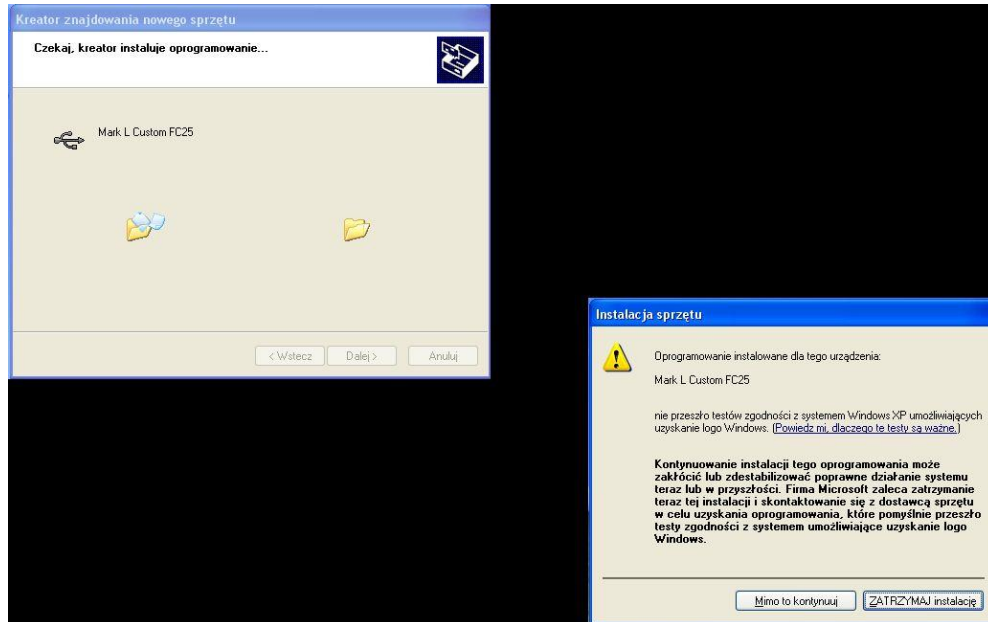

9. The device has been successfully found and installed

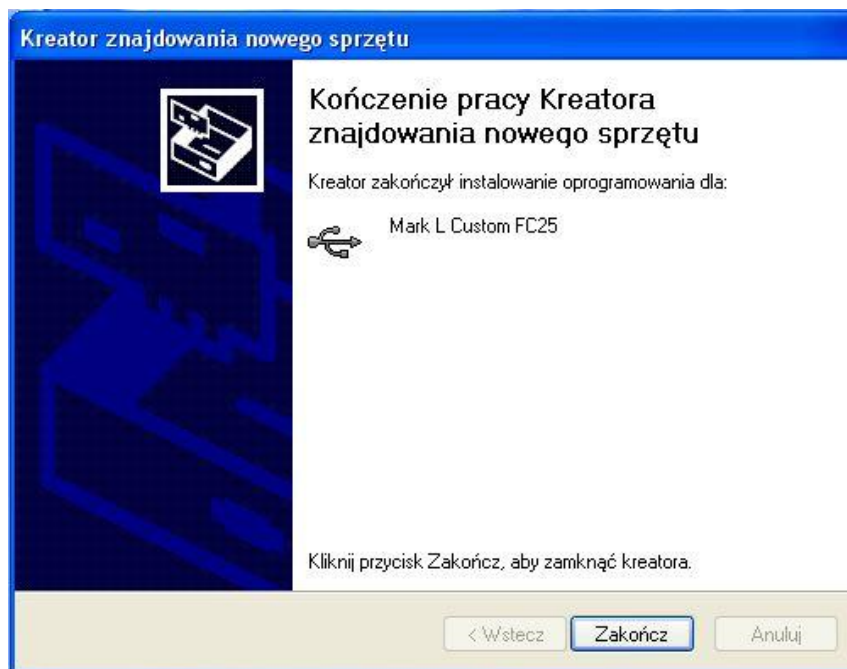

14-Fx-25 Programmer

1. Before running the Fx25 Programmer software, press 2nd button on the Fx-25 Controller and enter the Fx-25 MENU after please launch FX25 Programmer. **This is critical for the computer to communicate with the controller.**
2. Open the PORT tab and select the AUTO DETECT.

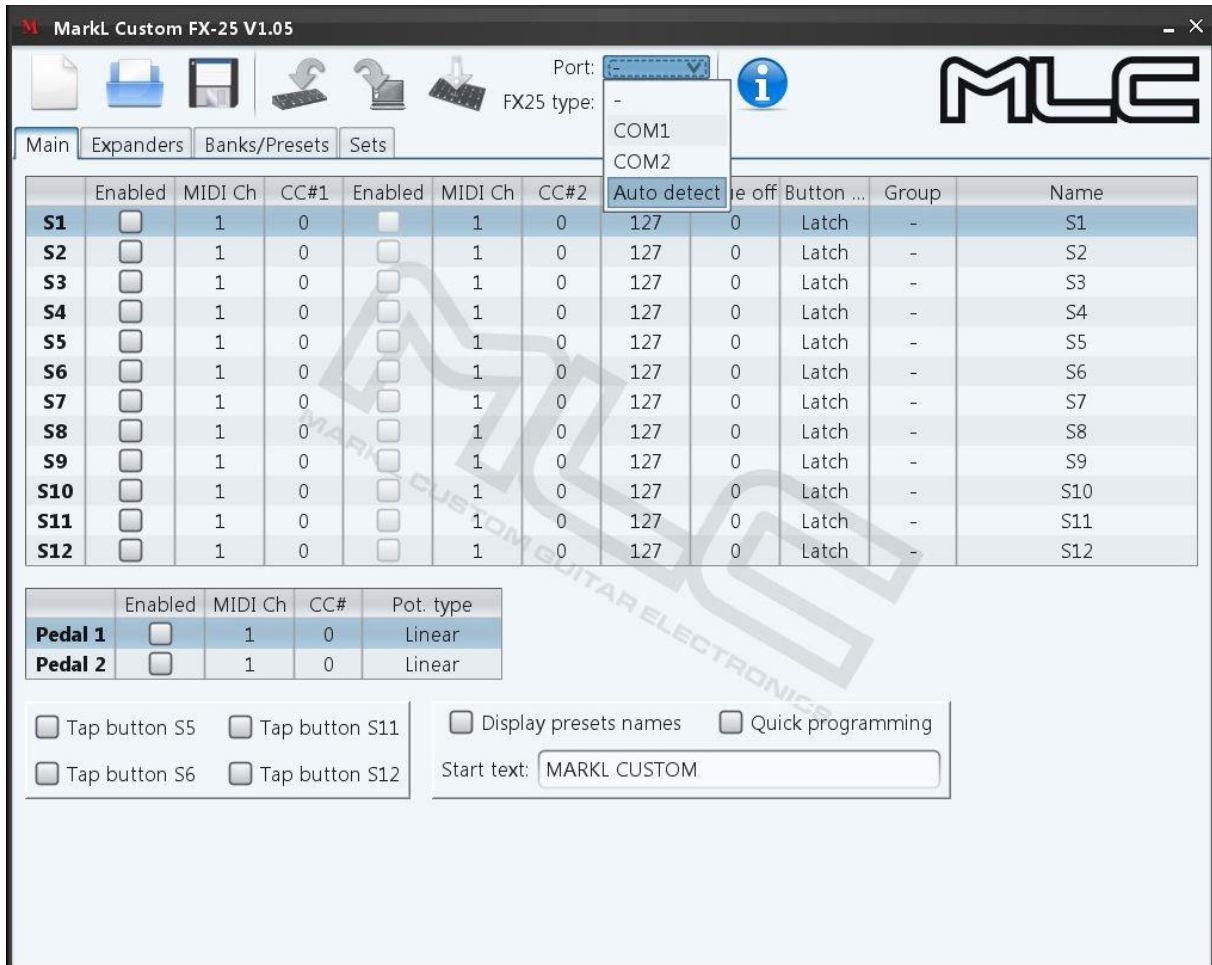

3. When your controller was found please select RECEIVE CONFIG
 - The program will now extract the last saved configuration from the FX-25.**IT IS STRONGLY ADVISED TO RECEIVE THE CONFIGURATION FROM THE CONTROLLER FIRST, IN ORDER NOT TO LOSE PREVIOUSLY SAVED SETTINGS**

4. If the configuration is successfully read....

5. We can now move to EDITING ☺

6. Set the quick access buttons S1-S12 and/or virtual expanders to increase the number of buttons to S27.

7. In the MAIN menu You can change the MIDI channel, CC command number, effect description, expression pedal global settings and TAP TEMPO buttons. Additionally You can change the Start-Up text.

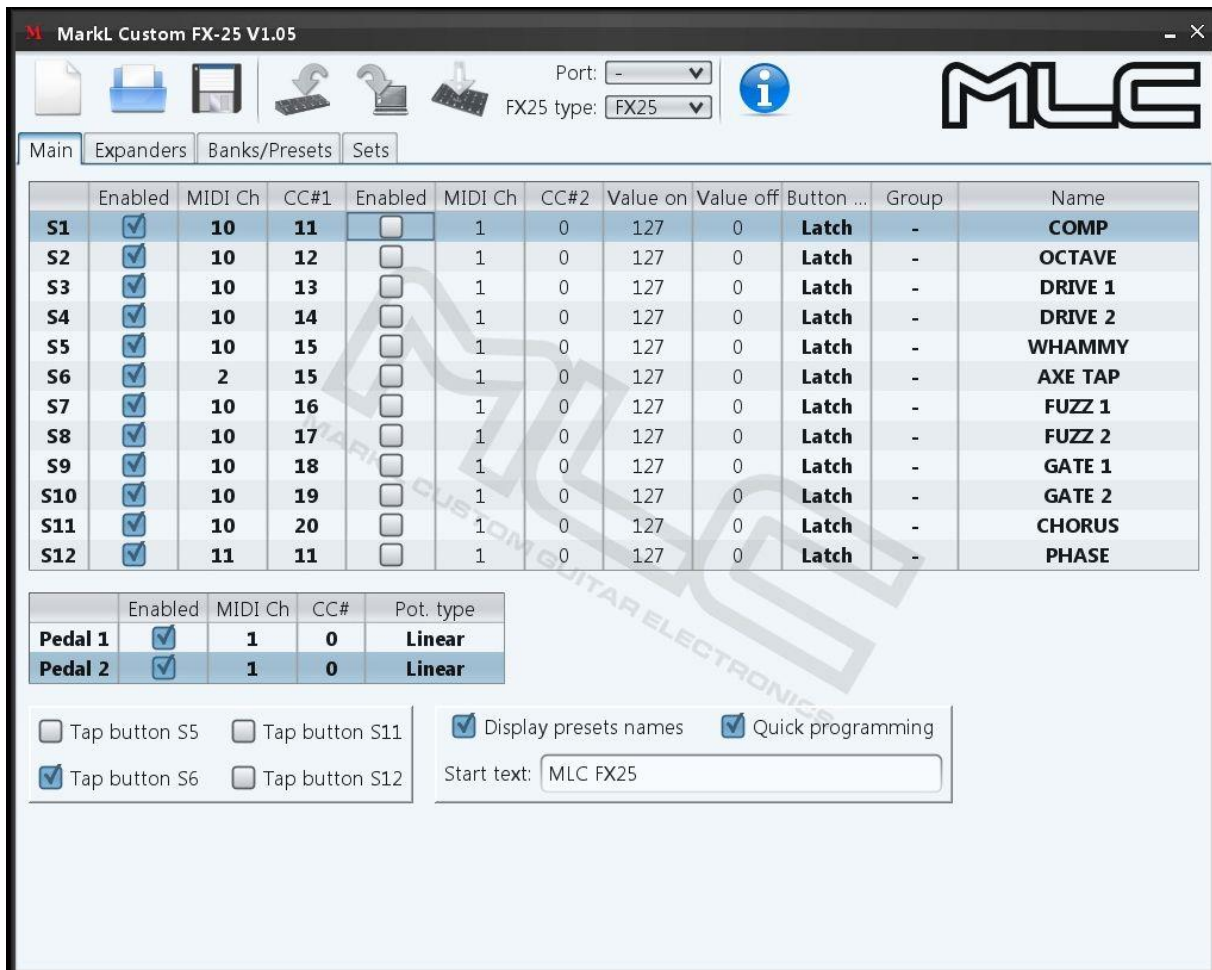

MIDI SYSTEM CONTROL Fx-25 INSTRUCTION MANUAL
PAGE 51

MarkL Custom FX-25 V1.05

Port: -
FX25 type: FX25

Main Expanders Banks/Presets Sets

Expander #1

	Enabled	MIDI Ch	CC#1	Enabled	MIDI Ch	CC#2	Value on	Value off	Button ...	Group	Name
S13	<input checked="" type="checkbox"/>	11	12	<input type="checkbox"/>	1	0	127	0	Latch	-	FLANGER
S14	<input checked="" type="checkbox"/>	11	13	<input type="checkbox"/>	1	0	127	0	Latch	-	PHASE 2
S15	<input checked="" type="checkbox"/>	11	14	<input type="checkbox"/>	1	0	127	0	Latch	-	BOOST 1
S16	<input checked="" type="checkbox"/>	11	15	<input type="checkbox"/>	1	0	127	0	Latch	-	BOOST 2
S17	<input checked="" type="checkbox"/>	11	16	<input type="checkbox"/>	1	0	127	0	Latch	-	DRY
S18	<input checked="" type="checkbox"/>	11	17	<input type="checkbox"/>	1	0	127	0	Latch	-	TUN/MUTE

Expander #2

	Enabled	MIDI Ch	CC#1	Enabled	MIDI Ch	CC#2	Value on	Value off	Button ...	Group	Name
S19	<input checked="" type="checkbox"/>	11	18	<input type="checkbox"/>	1	0	127	0	Latch	-	AXE FX
S20	<input checked="" type="checkbox"/>	11	19	<input type="checkbox"/>	1	0	127	0	Latch	-	S20TC 22
S21	<input checked="" type="checkbox"/>	11	20	<input type="checkbox"/>	1	0	127	0	Latch	-	LEXICON
S22	<input checked="" type="checkbox"/>	12	11	<input type="checkbox"/>	1	0	127	0	Latch	1	AMP 1
S23	<input checked="" type="checkbox"/>	12	12	<input type="checkbox"/>	1	0	127	0	Latch	1	AMP 2
S24	<input checked="" type="checkbox"/>	12	13	<input type="checkbox"/>	1	0	127	0	Latch	1	AMP 3
S25	<input checked="" type="checkbox"/>	10	21	<input checked="" type="checkbox"/>	4	0	127	0	Latch	2	AMP CH1
S26	<input checked="" type="checkbox"/>	10	22	<input checked="" type="checkbox"/>	4	0	127	0	Latch	2	AMP CH2
S27	<input checked="" type="checkbox"/>	10	23	<input checked="" type="checkbox"/>	4	0	127	0	Latch	2	AMP CH3

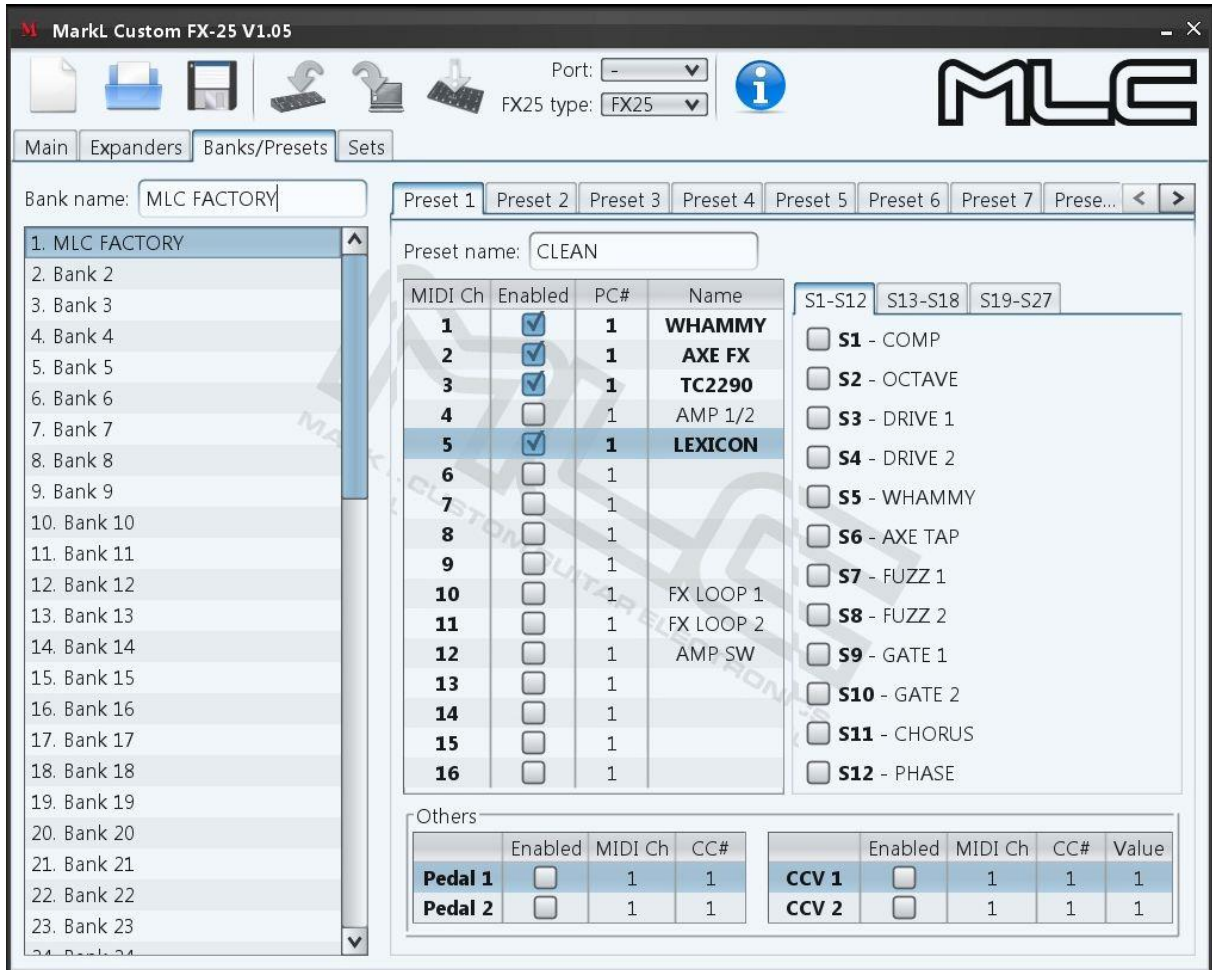

8. In the Banks tab set the PC Program Change commands, effects on-off, expression pedals. Every preset can be fine-tuned separately.

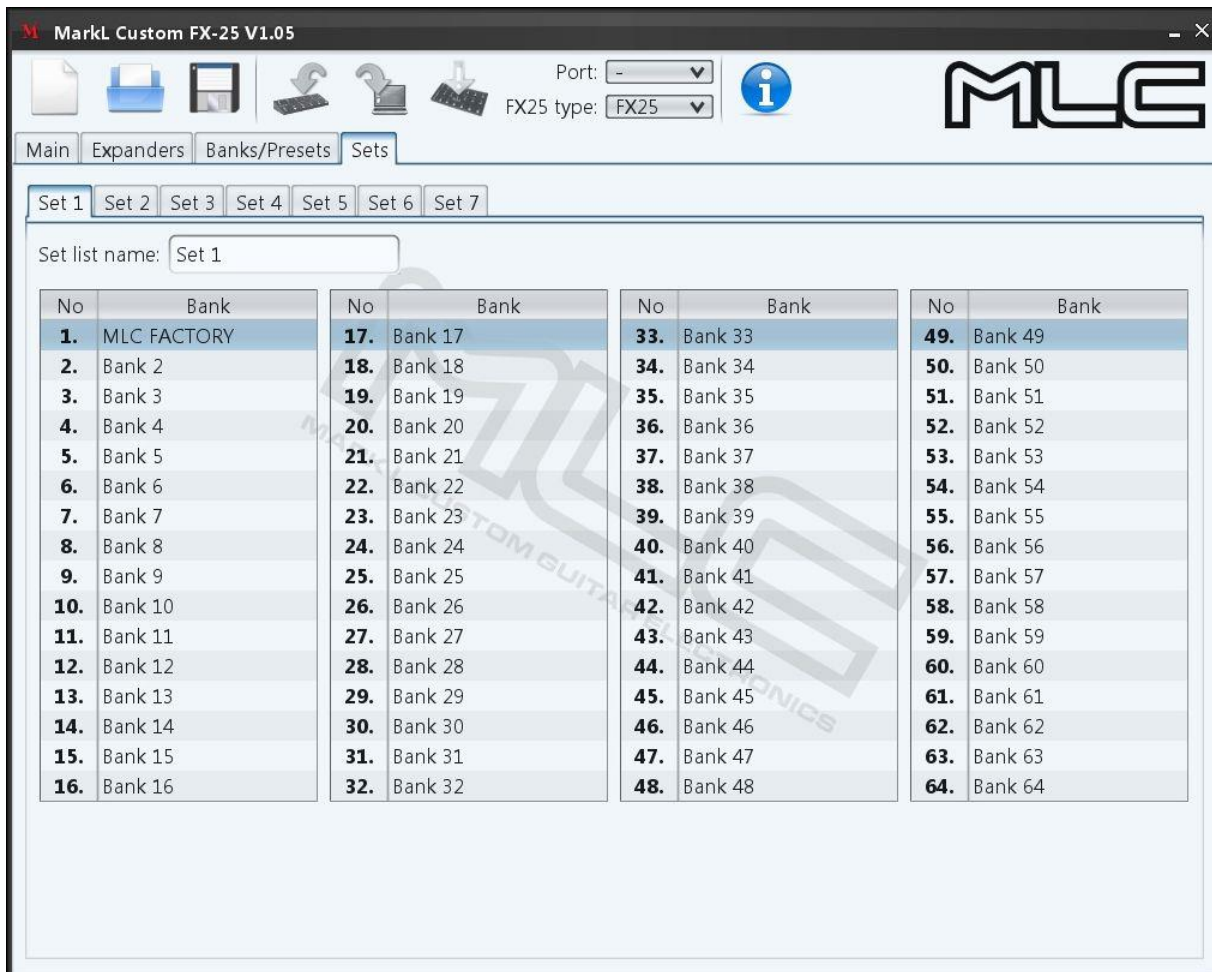

9. In the SET LISTS tab, You can mix banks/songs, while leaving the effects setting unchanged.

10. If You finish editing, send it to the FX-25.

13. After sending the configuration click “OK”

14. Exit the program mode on the controller by pressing 2nd. The FX-25 is now ready to *rock’n’roll*.

15- Firmware Update

In order to update the FIRMWARE on our FX-25, connect to a computer and visit www.marklcustom.com/products/fc-25.html to download the most up-to-date firmware. Any and all system settings will be saved, but it is advised to make a back-up copy.

1. Before launching the FX-25 Programmer editing software, the Controller must be put into MENU mode by pressing 2nd. This will allow the computer to connect to the controller.
2. Open the COMMUNICATION tab and select the COM port, which has been previously assigned to the controller.
3. Select UPDATE FIRMWARE
4. Open the file from the location in which it has been saved, f.e. FC25_v2.04.frm

IT IS VERY IMPORTANT NOT TO CHOOSE ANY FILE OTHER THAN .FRM AS THIS MAY PERMANENTLY DAMAGE THE CONTROLLER

5. On the screen You will see “file being sent to the controller”, the FX-25 Controller display will show the progress bar and the alpha display may show various unimportant symbols.
6. The update has successfully finished. Automatically, the controller re-enters program mode and then standby.