

Automatic Airless Spray Guns

311053E

Part No. 288048

For airless spraying of paints and coatings.

Part No. 288554

For sealant streaming applications.

4000 psi (28 MPa, 280 bar) Maximum Working Fluid Pressure

Mounting manifolds must be ordered separately. Refer to Parts section.



Important Safety Instructions

Read all warnings and instructions in this manual.
Save these instructions.

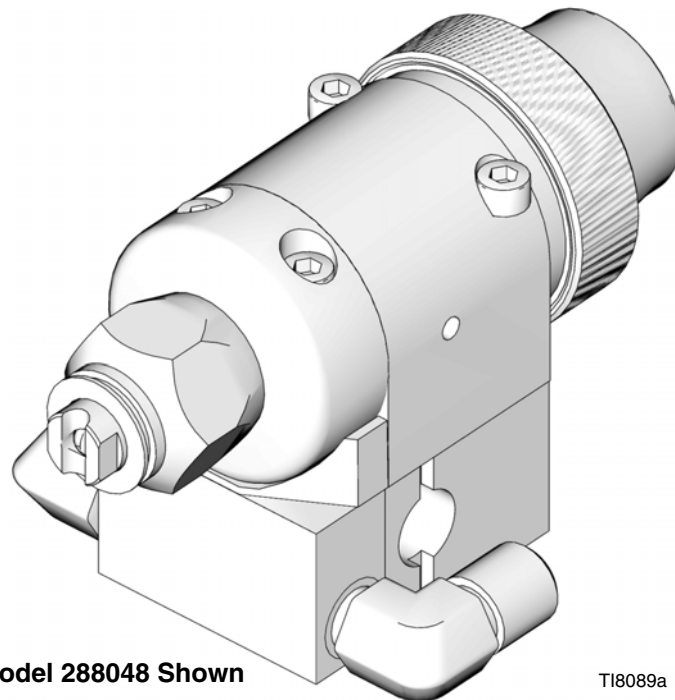

Model 288048 Shown

T18089a

Contents

Related Manuals	2	Troubleshooting	14
Warnings	3	General Troubleshooting	14
Installation	5	Spray Pattern Troubleshooting	16
Ventilate Spray Booth	5	Service	17
Configure Gun and Manifold	5	Disassembly	17
Install Air Fittings	6	Reassembly	19
Ground System	6	Parts	20
Mount Gun	7	GG0 Series Tip Selection Charts	24
Setup	8	Sealer Application Tip and Air Cap	
Air Line and Accessory Recommendations	8	Selection Charts	25
Fluid Line and Accessory Recommendations	8	Shower Tip	25
Flush Spray Gun	10	Streaming Tips	25
Install Spray Tip	10	Single Orifice Fan Pattern Spray Tips	25
Adjust Spray Pattern	10	Accessories	26
Adjust a Streaming Tip	10	Dimensions	27
Operation	11	Mounting Hole Layout	28
Pressure Relief Procedure	11	Technical Data	29
Apply the Fluid	11	Graco Standard Warranty	30
Daily Gun Care	12	Graco Information	30
General System Maintenance	13		
Daily Cleaning Procedure	13		
Daily Flushing Procedure	13		

Related Manuals





The Automatic Airless Spray Guns manual is available in the following languages. See the following chart for specific language and part number.





Manual	Language
311053	English
311665	Chinese
311666	Danish
311667	Dutch
311668	Finnish
311669	French
311670	German
311671	Italian

Manual	Language
311672	Japanese
311673	Korean
311674	Norwegian
311675	Polish
311676	Russian
311677	Spanish
311678	Swedish

Warnings

The following warnings are for the setup, use, grounding, maintenance, and repair of this equipment. The exclamation point symbol alerts you to a general warning and the hazard symbol refers to procedure-specific risk. Refer back to these warnings. Additional, product-specific warnings may be found throughout the body of this manual where applicable.

 WARNING	
	<p>EQUIPMENT MISUSE HAZARD</p> <p>Misuse can cause death or serious injury.</p> <ul style="list-style-type: none"> • Do not operate the unit when fatigued or under the influence of drugs or alcohol. • Do not exceed the maximum working pressure or temperature rating of the lowest rated system component. See Technical Data in all equipment manuals. • Use fluids and solvents that are compatible with equipment wetted parts. See Technical Data in all equipment manuals. Read fluid and solvent manufacturer's warnings. For complete information about your material, request MSDS forms from distributor or retailer. • Check equipment daily. Repair or replace worn or damaged parts immediately with genuine manufacturer's replacement parts only. • Do not alter or modify equipment. • Use equipment only for its intended purpose. Call your distributor for information. • Route hoses and cables away from traffic areas, sharp edges, moving parts, and hot surfaces. • Do not kink or over bend hoses or use hoses to pull equipment. • Keep children and animals away from work area. • Comply with all applicable safety regulations.
 	<p>SKIN INJECTION HAZARD</p> <p>High-pressure fluid from gun, hose leaks, or ruptured components will pierce skin. This may look like just a cut, but it is a serious injury that can result in amputation. Get immediate surgical treatment.</p> <ul style="list-style-type: none"> • Do not point gun at anyone or at any part of the body. • Do not put your hand over the spray tip. • Do not stop or deflect leaks with your hand, body, glove, or rag. • Follow Pressure Relief Procedure in this manual, when you stop spraying and before cleaning, checking, or servicing equipment.
	<p>FIRE AND EXPLOSION HAZARD</p> <p>Flammable fumes, such as solvent and paint fumes, in work area can ignite or explode. To help prevent fire and explosion:</p> <ul style="list-style-type: none"> • Use equipment only in well ventilated area. • Eliminate all ignition sources; such as pilot lights, cigarettes, portable electric lamps, and plastic drop cloths (potential static arc). • Keep work area free of debris, including solvent, rags and gasoline. • Do not plug or unplug power cords, or turn power or light switches on or off when flammable fumes are present. • Ground all equipment in the work area. See Grounding instructions. • Use only grounded hoses. • Hold gun firmly to side of grounded pail when triggering into pail. • If there is static sparking or you feel a shock, stop operation immediately. Do not use equipment until you identify and correct the problem. • Keep a working fire extinguisher in the work area.

 WARNING	
	<p>PRESSURIZED EQUIPMENT HAZARD</p> <p>Fluid from the gun/dispense valve, leaks, or ruptured components can splash in the eyes or on skin and cause serious injury.</p> <ul style="list-style-type: none"> • Follow Pressure Relief Procedure in this manual, when you stop spraying and before cleaning, checking, or servicing equipment. • Tighten all fluid connections before operating the equipment. • Check hoses, tubes, and couplings daily. Replace worn or damaged parts immediately.
	<p>TOXIC FLUID OR FUMES HAZARD</p> <p>Toxic fluids or fumes can cause serious injury or death if splashed in the eyes or on skin, inhaled, or swallowed.</p> <ul style="list-style-type: none"> • Read MSDS's to know the specific hazards of the fluids you are using. • Store hazardous fluid in approved containers, and dispose of it according to applicable guidelines.
	<p>PERSONAL PROTECTIVE EQUIPMENT</p> <p>You must wear appropriate protective equipment when operating, servicing, or when in the operating area of the equipment to help protect you from serious injury, including eye injury, inhalation of toxic fumes, burns, and hearing loss. This equipment includes but is not limited to:</p> <ul style="list-style-type: none"> • Protective eyewear • Clothing and respirator as recommended by the fluid and solvent manufacturer • Gloves • Hearing protection

Installation

Ventilate Spray Booth



 Check and follow all National, State, and Local codes regarding air exhaust velocity requirements.

Check and follow all local safety and fire codes.

Configure Gun and Manifold

(Order manifold separately. See **Accessories**, page 26.)

Manifolds 241161 and 241162

The gun is supplied with an internal fluid plug (4). See FIG. 1. To use the gun in a circulating system, remove the internal plug. In a non-circulating system, leave the plug in place to minimize flush time.

Circulating System

1. Apply anti-seize lubricant 222955 to the threads and mating faces of the manifold (102) and the elbows (107), supplied unassembled.
2. Install the elbows (107) in both fluid ports of the manifold (102).
3. Connect the fluid supply line to one elbow and the fluid return line to the other. The manifold fluid ports are reversible.

Non-circulating System:

1. Apply anti-seize lubricant 222955 to the threads and mating faces of manifold (102), plug (109), and elbow (107), supplied unassembled.
2. Install an elbow (107) in one fluid port of the manifold (102), and a plug (109) in the other port.
3. Install the internal plug (4) in the gun fluid port on the same side as the manifold plug.
4. Connect the fluid supply line to the manifold elbow (107). See FIG. 1.
5. Install the gun on the manifold, using the four screws (14). Start the threads of all four screws, and tighten the front two screws first, and then tighten the back two screws to 65 in-lb (7.3 N•m).

 Remove when used in circulating systems.

 Replace with an elbow (107) when used in circulating systems.

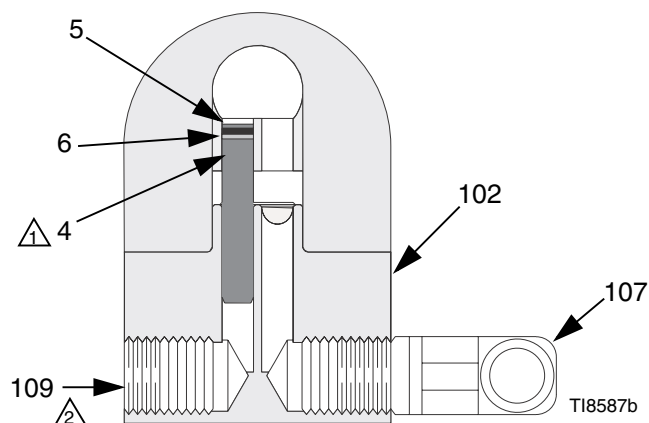

FIG. 1: Non-Circulating Setup (Cutaway View)

Install Air Fittings

1. Install 1/4 in. tube fitting into the cylinder (CYL) air port.
2. Install plugs into the atomization (ATOM) air port and the fan (FAN) air port.

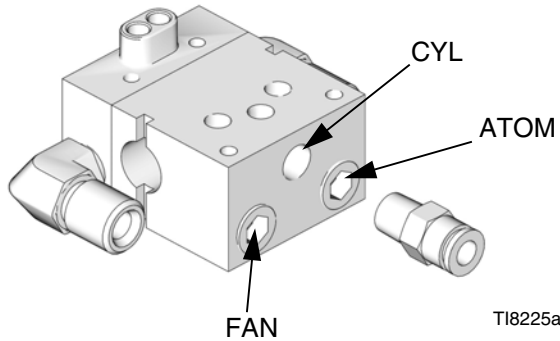
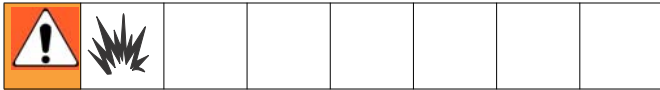

FIG. 2: Air Fittings

Ground System



The following grounding instructions are minimum requirements for a system. Your system may include other equipment or objects that must be grounded. Check your local electrical code for detailed grounding instructions for your area and type of equipment. Your system must be connected to a true earth ground.

Ground Pump

Ground the pump by connecting a ground wire and clamp between the fluid supply and a true earth ground as instructed in your separate pump instruction manual.

Ground Air Compressors and Hydraulic Power Supplies

Ground them according to the manufacturer recommendations.

Ground Air, Fluid, and Hydraulic Hoses Connected to Pump

Use only electrically conductive hoses with a maximum of 100 ft (30.5 m) combined hose length to ensure grounding continuity. Check the electrical resistance of your air and fluid hoses at least once a week. If the total resistance to ground exceeds 25 megohms, replace the hose immediately.

 Use a meter that is capable of measuring resistance at this level.

Ground Spray Gun

Ground the spray gun by connecting it to a properly grounded fluid hose and pump.

Ground Fluid Supply Container

Ground the fluid supply container according to local code.

Ground Object Being Sprayed

Ground the object being sprayed according to local code.

Ground Solvent Pails

Ground all solvent pails that are used with flushing according to local code. Use only metal pails, which are conductive. Do not place the pail on a non-conductive surface, such as paper or cardboard, which interrupts the grounding continuity.

Mount Gun

Reciprocating Arm Rod Mount

Manifolds 241161 and 241162

To mount the gun on a reciprocating arm rod [0.5 in. (13 mm) diameter maximum]:

1. Insert the mounting bar (A) through the hole in the manifold as shown in FIG. 3.

 Use the 1/8 in. alignment pin (P) to assist in orienting the gun.

2. Secure the gun to the bar by tightening the mounting screw (B).
3. Ensure the tip of the gun is 8 to 10 in. (150 to 200 mm) from the surface of the object being sprayed.

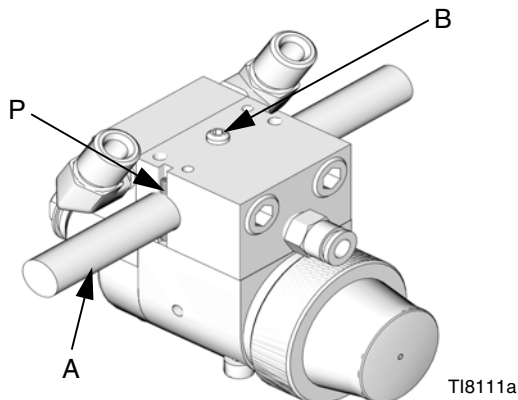

TI8111a

FIG. 3: Reciprocating Arm Mount

Stationary Support Mount

All Manifolds

To mount the gun on a stationary support (refer to FIG. 4. and **Mounting Hole Layout**, page 28):

1. Attach the gun to the support with two M5 x 0.8 cap-screws (C). The screws must be long enough to engage the threaded holes in the gun manifold to a depth of 1/4 in. (6 mm).
2. Ensure the tip of the gun is 8 to 10 in. (150 to 200 mm) from the surface of the object being sprayed.

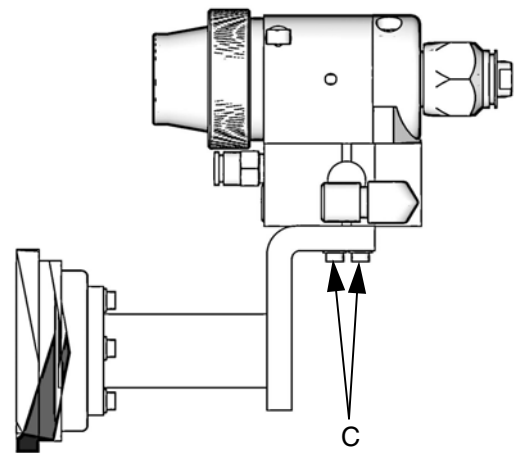

TI8112a

FIG. 4: Stationary Support Mount



Setup

Air Line and Accessory Recommendations

1. Install an air pressure regulator on the gun cylinder air supply line.

A minimum of 70 psi (0.49 MPa, 4.9 bar) air pressure must be supplied to the cylinder for proper operation. Air pressure opens the valve, a spring closes the valve. A three-way air valve, which exhausts cylinder air, is required.

2. Install a bleed-type air shutoff valve on the main air line. Install an additional bleed-type valve on each pump air supply line, downstream of the pump air regulator, to relieve air trapped between this valve and the pump after the air regulator is shut off.



						
---	---	--	--	--	--	--

The bleed-type air shutoff valve is required in your system to relieve air trapped between this valve and the pump after the air regulator is closed. Trapped air can cause the pump to cycle unexpectedly, which could result in serious injury.

3. Install a bleed-type air shutoff valve on the gun air cylinder supply line, downstream of the air regulator, to shut off air to the gun cylinder. Connect the air supply line to the gun cylinder air inlet (C). See Fig. 4.

 The cylinder air inlet accepts 1/4 in. (6.3 mm) O.D. tubing.

Fluid Line and Accessory Recommendations

						
---	---	--	--	--	--	--

- A fluid drain valve(s) is required in your system to assist in relieving fluid pressure in the displacement pump, hose and gun; triggering the gun to relieve pressure may not be sufficient.
- A fluid pressure regulator must be installed in the system if the pump's maximum working pressure exceeds the gun's maximum fluid working pressure (see the front cover).

1. Install a fluid filter and drain valve(s) close to the pump's fluid outlet.
2. Install a fluid pressure regulator to control fluid pressure to the gun.

 Some applications require fine-tuned control of fluid pressure. You can control fluid pressure more accurately with a fluid pressure regulator than by regulating the air pressure to the pump.

3. Install a fluid shutoff valve to shut off the fluid supply to the gun.
4. For paint spray applications, install an in-line fluid filter, part no. 210500, on the gun fluid inlet (F) to avoid clogging the spray tip with particles from the fluid. See Fig. 4.
5. Connect the electrically conductive fluid hose to the gun fluid inlet (F) or optional in-line filter.

Manifolds 288219 and 288220

6. In a circulating system, connect an electrically conductive fluid hose to the gun fluid outlet (G).

In a non-circulating system, remove the gun fluid outlet fitting (G) and plug the outlet port with the pipe plug (109) supplied.

KEY

- C Cylinder Air Inlet: accepts 1/4 in. (6.3 mm) O.D. tubing
- F Fluid Inlet: 1/4-18 nptf or #5 JIC (1/2-20 unf)
- G Fluid Outlet (circulating gun only): 1/4-18 nptf or #5 JIC (1/2-20 unf)

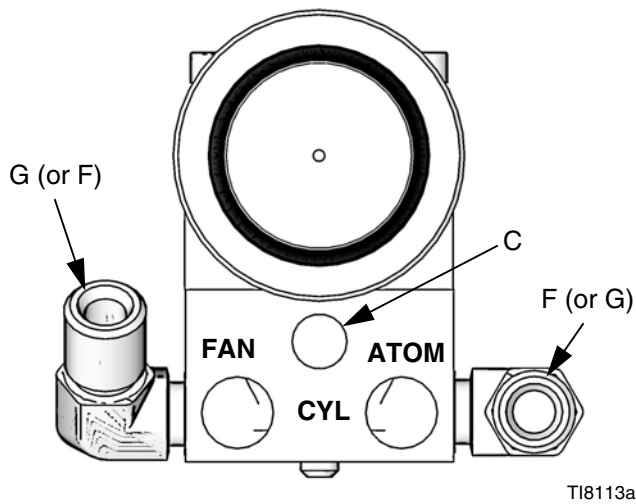

FIG. 5

Manifold 244930

7. This manifold is equipped with passages for circulating water to maintain the temperature of the gun. Ports provided are:

- Side water inlet, 1/4 npt(f)
- Top water outlets, 1/8 npt(f)
- Side RTD sensor, 1/8 npt(f)

See **Accessories**, page 26, for available fittings and sensors.

KEY

- L Water Outlet: 1/8 npt(f)
- M Air Inlet (to open valve): 1/8 npt(f)
- N Fluid Inlet: 3/8(f)
- P Water Inlet: 1/4 npt(f)

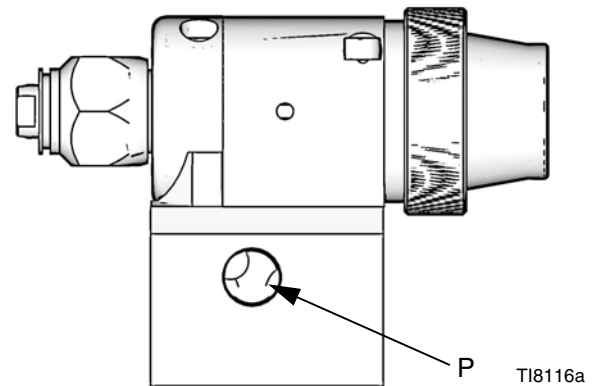
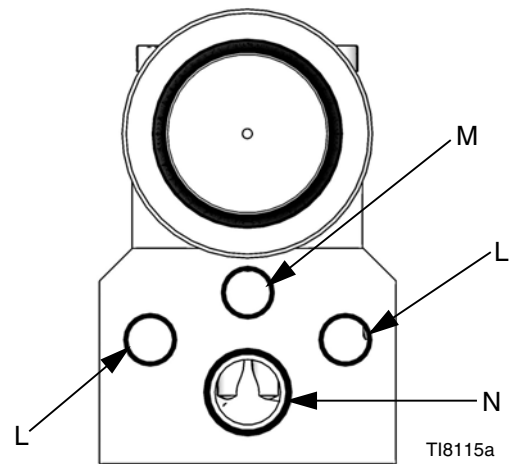
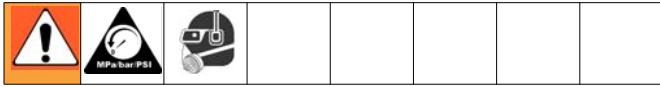

FIG. 6

Flush Spray Gun



Before running any paint through the spray gun:

1. Flush the gun with a solvent that is compatible with the fluid to be sprayed, using the lowest possible fluid pressure and grounded metal container.
2. Perform **Pressure Relief Procedure**; see page 11.

Install Spray Tip



1. Perform **Pressure Relief Procedure**; see page 11.
2. Install the spray tip (H) and the gasket (J) in the tip retainer nut (K). Screw the assembly firmly onto the gun. Tighten the assembly with a wrench. See Fig. 7.

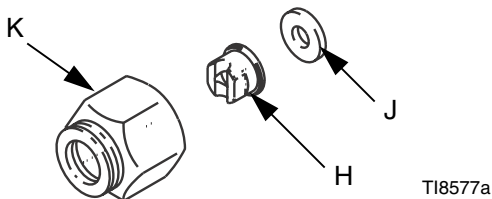

FIG. 7: Install Spray Tip

Gaskets are included with Streaming Tips 270XXX or Fan Tips 182XXX.

Adjust Spray Pattern



1. To adjust the spray pattern direction with fan tips, orient the slot in the tip horizontally for a horizontal pattern and vertically for a vertical pattern. See Fig. 7.
2. Start the pump. Adjust the fluid pressure until the spray is completely atomized. Use the lowest pressure necessary to get the desired results. Higher pressure may not improve the spray pattern and will cause premature tip wear and pump wear.
3. The spray tip orifice and spray pattern angle determines the coverage and size of pattern. When more coverage is needed, follow the **Pressure Relief Procedure**, page 11, and install a larger spray tip rather than increasing fluid pressure.

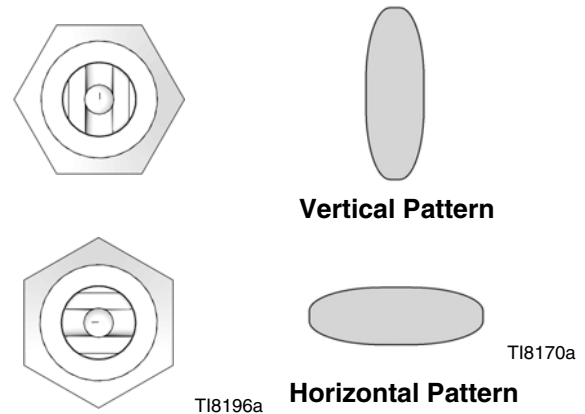

FIG. 8: Spray Pattern

Adjust a Streaming Tip

Select a tip that will supply a stream at the required flow rate at the lowest pressure.

Operation

Pressure Relief Procedure



1. Shut off the power to the pump.
2. Turn off the air and fluid supply to the gun.
3. Close the bleed-type master air valve (required in the system).
4. Trigger the gun into a grounded metal waste container to relieve the fluid pressure.

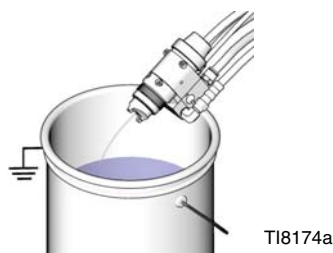

FIG. 9: Pressure Relief

5. Open the pump drain valve (required in the system) to help relieve fluid pressure in the displacement pump. In addition, open the drain valve connected to the fluid pressure gauge (in a system with fluid regulation) to help relieve fluid pressure in the hose and gun. Triggering the gun to relieve pressure may not be sufficient. Have a container ready to catch the drainage.
6. Leave the drain valve(s) open until you are ready to spray again.
7. If you suspect that the spray tip or hose is completely clogged or that pressure has not been fully relieved after following the steps above, very slowly loosen the hose end coupling and relieve pressure gradually, then loosen the coupling completely. Now clear the tip or hose obstruction.

Apply the Fluid

Adjust the system control device, if it is automatic, so the gun starts spraying just before meeting the workpiece and stops as soon as the workpiece has passed. Keep the gun a consistent distance, 8 to 10 in. (200 to 250 mm), from the surface of the object being sprayed.

To achieve best results when applying fluid:

- Keep gun perpendicular and 8 to 10 inches (200 to 250 mm) from object being sprayed.
- Use smooth, parallel strokes across surface to be sprayed with 50% overlap. See FIG. 10.

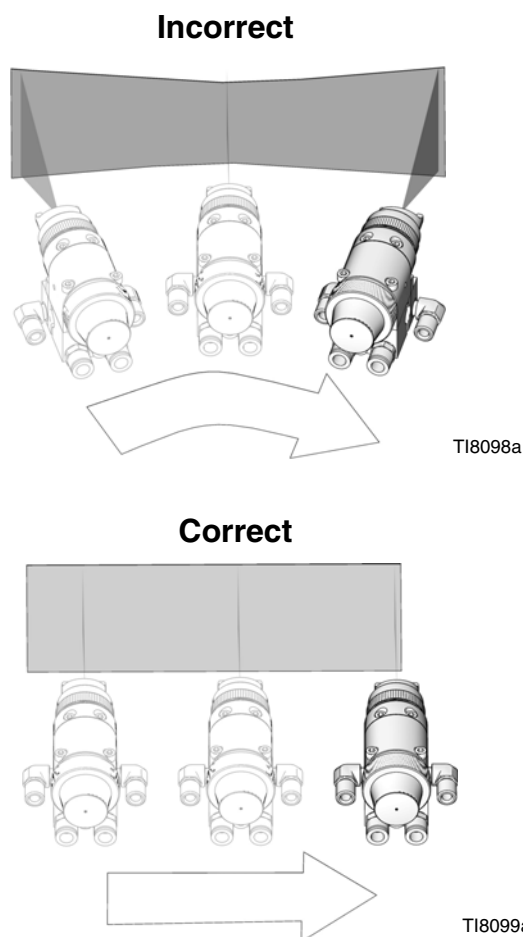

FIG. 10: Correct Spray Method

Daily Gun Care



CAUTION

Methylene chloride with formic or propionic acid is not recommended as a flushing or cleaning solvent with this gun as it will damage aluminum and nylon components.

CAUTION

Solvent left in gun air passages could result in a poor quality paint finish. Do not use any cleaning method which may allow solvent into the gun air passages.

Do not point the gun up while cleaning it.

Do not wipe the gun with a cloth soaked in solvent; ring out the excess.



T18100a



T14827a

Do not immerse the gun in solvent.



T18101a

General System Maintenance

- Perform **Pressure Relief Procedure**, page 11.
- Clean the fluid and air line filters daily.
- Check for any fluid leakage from the gun and fluid hoses. Tighten fittings or replace equipment as needed.
- Flush the gun before changing colors and whenever you are done operating the gun.

Daily Cleaning Procedure

CAUTION

This gun is not adjustable. To ensure proper shutoff, screw the piston cap (18) onto the housing (1) until it bottoms out.

 Clean the front of the tip frequently during the day to help reduce buildup.

1. Follow **Pressure Relief Procedure**, page 11.
2. Clean the outside of the gun with a soft cloth dampened with compatible solvent.
3. To avoid damaging the spray tip, clean it with a compatible solvent and soft brush.
4. If using an in-line filter, remove and clean it thoroughly in a compatible solvent.
5. Clean the system's fluid filter and air line filter.

Daily Flushing Procedure



To reduce the risk of serious injury, including splashing fluid in the eyes or on the skin, or static electric discharge when flushing:

- Ensure that the entire system, including flushing pails, are properly grounded.
- Remove the spray tip.
- Maintain metal to metal contact between the gun and the flushing pail.
- Use the lowest possible pressure.

 Flush the pump and gun before the fluid can dry in it.

If it is available, the flushing procedure provided in the pump or sprayer manual should be used instead of this procedure.

1. Follow **Pressure Relief Procedure**, page 11.
2. Remove the spray tip. Clean the parts.
3. Supply a compatible solvent to the gun fluid inlet.
4. Start the pump and operate it at its lowest pressure.
5. Trigger the gun into a grounded metal waste container until all the material is removed from the gun passages.

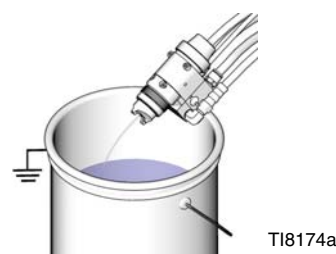



FIG. 11

6. Follow **Pressure Relief Procedure**, page 11.
7. Disconnect the solvent supply.

Troubleshooting



 Check all possible remedies in the troubleshooting charts before disassembling the gun.

Some improper patterns are caused by the improper balance between air and fluid. Refer to **Spray Pattern Troubleshooting**, page 16.

General Troubleshooting

Problem	Cause	Solution
Fluid leakage through venting holes.	Worn o-rings or packings on needle assembly (12).	Replace o-rings or needle assembly.
Air leakage through venting hole.	Worn o-ring (23).	Check and replace as needed.
Air leakage from back of gun.	Worn o-rings (22, 23).	Replace o-rings.
Fluid leakage from front of gun.	Fluid needle (12) is dirty, worn, or damaged Dirty or worn seat (10, 41). Spray tip seal is leaking. Seat (10, 41) is insufficiently tightened or gasket (11) is missing or worn from multiple uses.	Clean or replace fluid needle. Clean or replace the seat (10, 41) and gasket (11). The gasket must be replaced whenever you remove the seat from the gun. Tighten nut (7) or replace spray tip gasket (8). Tighten seat (10, 41) and replace gasket (11). The gasket must be replaced whenever you remove the seat from the gun.

Problem	Cause	Solution
Fluid needle will not trigger	<p>Loose or missing fluid needle stop (17) or setscrew (16).</p> <p>Broken fluid needle (12).</p> <p>Air leaking around piston (21).</p> <p>Swollen piston o-ring (22).</p> <p>Insufficient air pressure on the trigger.</p> <p>Spray tip (9) is plugged.</p> <p>Plug (4) is in the incorrect fluid port.</p>	<p>Replace stop (17) or tighten setscrew (16).</p> <p>Replace fluid needle (12).</p> <p>Replace o-ring (22) or piston assembly (21).</p> <p>Replace o-ring (22). Do not immerse piston in solvent.</p> <p>Increase the air pressure or clean the air line.</p> <p>Clean the spray tip (9).</p> <p>Move the plug to the fluid port consistent with manifold plumbing, unless you are using the gun in a circulating system. If you are, all fluid ports should be open, both inside the gun and on the manifold.</p>
Fluid does not shut off.	<p>Piston cap (18) not fully tightened.</p> <p>Spring (19) not in place.</p> <p>Swollen piston o-ring (22).</p>	<p>Tighten piston cap until it bottoms out.</p> <p>Check spring position.</p> <p>Replace o-ring. Do not immerse piston in solvent</p>

Spray Pattern Troubleshooting

Problem	Cause	Solution
Fluttering spray.	Insufficient fluid supply. Air in paint supply line.	Adjust fluid regulator or fill fluid supply tank. Check, tighten siphon hose connections, bleed air from paint line.
Spitting spray.	Worn seat (10, 41) or needle (12) ball. Dirty spray tip (9). Swollen piston o-ring (22).	Inspect seat and needle for wear. Replace if necessary. The gasket (11) must be replaced whenever you remove the seat from the gun. Clean. Replace o-ring. Do not immerse piston in solvent.
Irregular pattern.	Fluid build-up or spray tip partially plugged.	Clean spray tip; see Daily Gun Care , page 12.
Air cap loosening. (Sealant gun only)	Air cap (18) not properly tightened. Gasket (38) worn.	Tighten. See Reassembly , page 19, step 13. Replace gasket.

Service



 Follow the Service Notes in Figs. 8 and 9 when reassembling the gun.

Gun repair kits are available. See page 18. Reference numbers marked with an asterisk (*) in the service procedures are included with the 288171 Air Seal Repair Kit. Reference numbers marked with a symbol (†) in the service procedures are included with the 288137 Fluid Repair Kit.

Disassembly

1. Follow **Pressure Relief Procedure**, page 11.
2. Unscrew the four screws (14) and remove the gun from the manifold.
3. Unscrew the tip retainer nut (7). Remove the spray tip (9) and gasket (8). See Figs. 8 and 9.
4. Remove the cap (18) from the piston housing (1). Remove the springs (20 and 19).
5. Using the supplied wrench (34), loosen the fluid needle setscrew (16). Remove the needle stop (17).
6. Remove the seat (10, 41).

CAUTION

Be sure to keep the needle straight when removing it from the gun. If the needle is bent it must be replaced.

7. Pull the needle assembly (12) straight out the front of the gun. Remove the o-rings (31) from the fluid needle (12).
8. Remove the gasket (11).

CAUTION

Install a new gasket (11) whenever you remove the seat (10, 41) from the gun. Failure to install a new gasket may result in fluid leaking into the air chamber.

9. Remove the piston. Using a pliers, pull the piston (21) out of the piston housing (1).
10. If necessary, unscrew the two screws (15) holding the fluid housing (2) to the piston housing (1). If worn, remove the gasket (13) from the bottom of the piston housing.

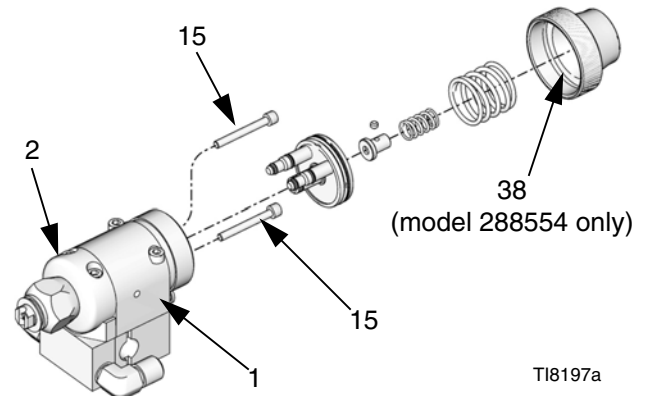
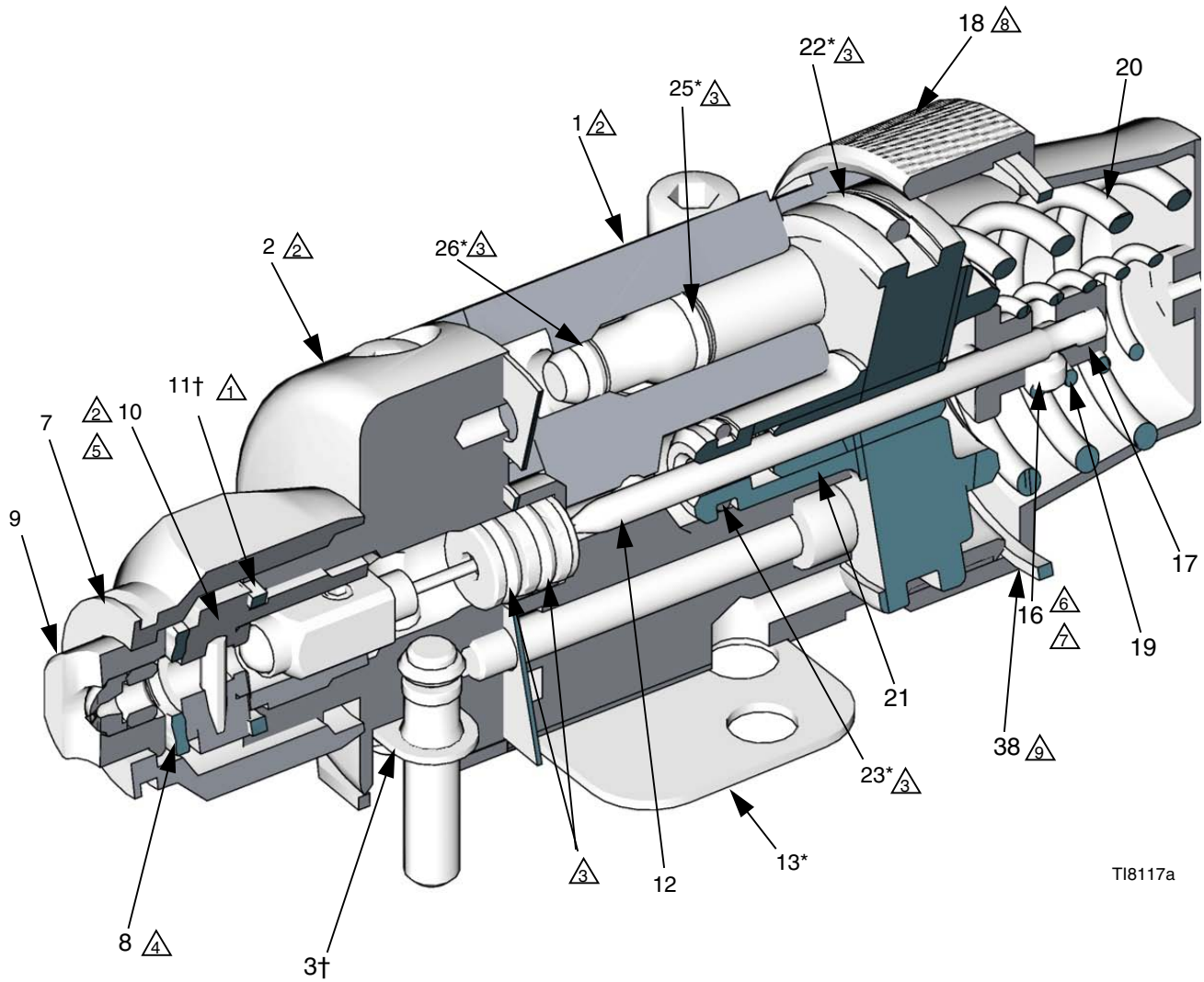

FIG. 12

T18197a

11. Remove the large o-ring (22) from the piston and the smaller o-ring (23) from the piston shaft. Remove the two o-rings (25, 26) from each of the piston stems. Check that the stems are solidly in place. If they are loose, replace the entire piston assembly (21).
12. Perform the following applicable step:
 - *Non-circulating Paint Guns:* Remove the fluid outlet port plug (4) and gasket (3) from the fluid housing (2). Remove the o-ring (5) and backup (6) from the plug.
 - *Circulating Paint Guns:* Remove the gasket (3) from the fluid housing (2).
 - *Sealant Gun:* Remove the gasket (3).
13. Clean all parts and replace any worn parts. When assembling, lubricate the threads with anti-seize lubricant.



TI8117a

SERVICE NOTES:

- △1 Seat gasket (11) must be replaced if seat (10) is removed or replaced to avoid fluid leakage
- △2 Lubricate threads with anti-seize lubricant
- △3 Lubricate with light-weight oil
- △4 Do not lubricate
- △5 Torque to 20-25 ft-lb (27-34 N•m)
- △6 Apply semi-permanent anaerobic sealant
- △7 Torque to 4-5 in-lb (0.45-0.56 N•m)
- △8 Tighten cap (18) until it bottoms out
- △9 Model 288554 only

FIG. 13

Reassembly

1. Perform the following applicable step:
 - *Non-circulating Paint Guns:* Lubricate the backup (6) and o-ring (5) and install them on the fluid outlet port plug (4). Install the plug in the fluid outlet port of the fluid housing (2). See FIG. 13. Reinstall the gasket (3).
 - *Circulating Paint Guns:* Reinstall the gasket (3) in the fluid housing (2).
 - *Sealant Gun:* Reinstall gasket (3).
2. Install the o-rings (22*, 23*) on the piston (21). Install two o-rings (25*, 26*) on each of the piston stems. Lubricate all the o-rings, the piston, and the piston stems.
3. Install the fluid housing (2) on the piston housing (1) with the gasket in place.
4. Reinstall the two screws (15) to secure the piston housing to the fluid housing (2). Torque to 30 in-lb (3.4 N•m).
5. Insert the piston (21) into the piston housing (1).
6. Remove the protective paper from the sticky side of the gasket (13*) and adhere the gasket to the bottom of the piston housing (1), making sure the three holes in the gasket are properly aligned with the matching holes in the housing.

CAUTION
Install a new gasket (11) whenever you remove the seat (10, 41) from the gun. Failure to install a new gasket may result in fluid leaking into the air chamber.

7. Install the o-rings (31) on the fluid needle assembly (12). Lubricate with light weight oil.

CAUTION
Be sure to keep the needle straight when installing it in the piston housing. If the needle is bent it must be replaced.

8. Insert the needle assembly (12) into the front of the fluid housing (2). Push it straight back through the piston.
9. Install a new gasket (11) in the fluid housing (2).
10. Lubricate the threads of the seat (10, 41). Screw it into the fluid housing (2) and torque to 20-25 ft-lb (27-34 N•m).
11. Install the needle stop (17) on the needle. Coat the setscrew (16) with semi-permanent anaerobic sealant and install the screw into the needle stop. Torque to 4-5 in-lb (0.45-0.56 N•m). Pull on the needle to make sure it seats fully.
12. Install the springs (19, 20).
13. Lubricate the threads of the piston housing (1). Screw the cap (18) onto the housing until it bottoms out.
14. *Model 288554 only:* Hand tighten cap (18) until it engages gasket (38). Then tighten cap a half turn more to ensure cap will not loosen during operation.
15. Do not lubricate the gasket (8). Install the spray tip (9) and gasket (8) in the tip retainer nut (7). Screw the assembly firmly onto the gun. Tighten the assembly with a wrench, but do not exceed 5 ft-lb (6.8 N•m) for model 233670 gun.
16. Reinstall the gun on the manifold with the four screws (14). Torque to 65 in-lb (7.3 N•m).

Parts

Model 288048

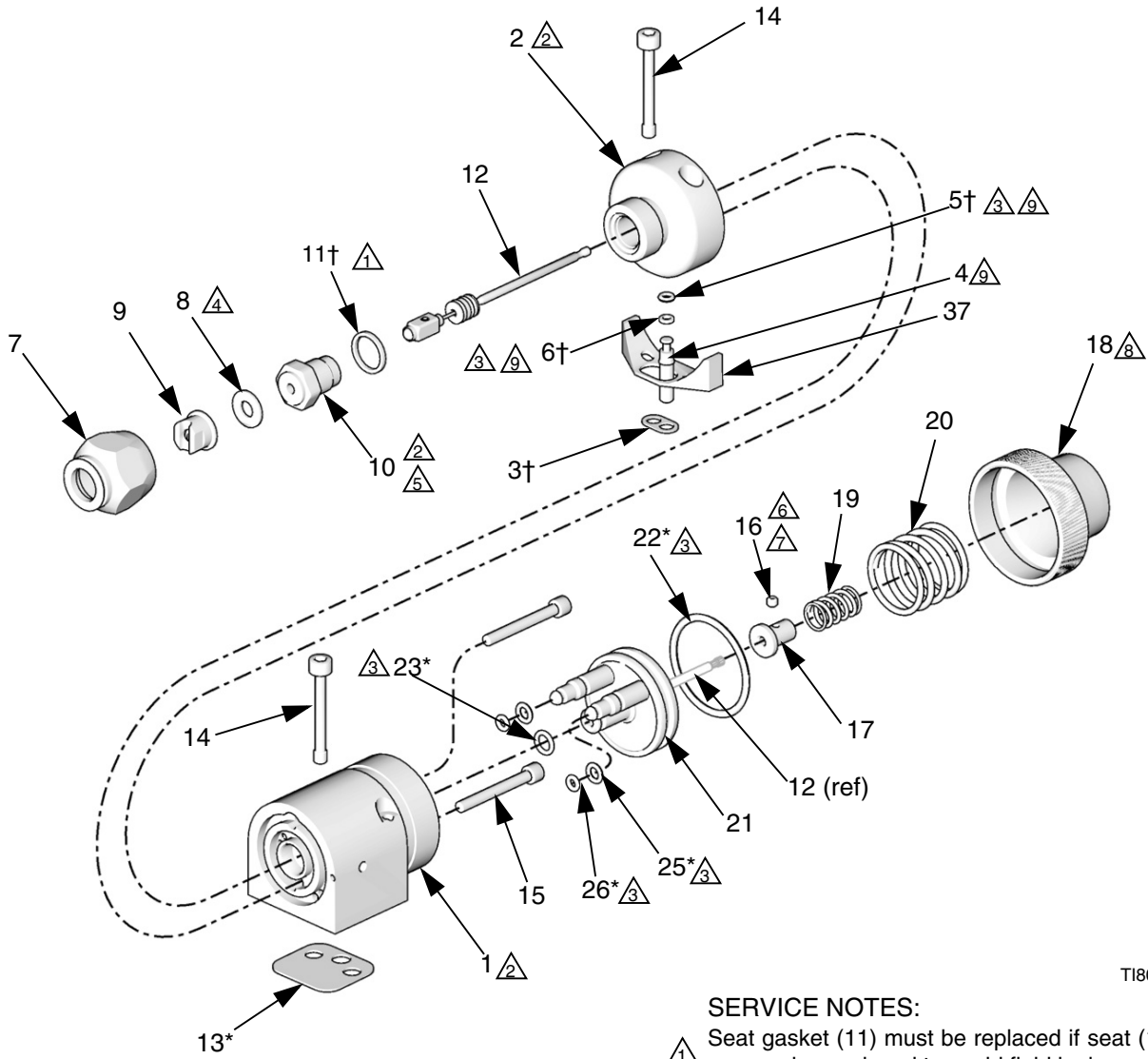

T18090a

SERVICE NOTES:

- △1 Seat gasket (11) must be replaced if seat (10) is removed or replaced to avoid fluid leakage
- △2 Lubricate threads with anti-seize lubricant
- △3 Lubricate with light-weight oil
- △4 Do not lubricate
- △5 Torque to 20-25 ft-lb (27-34 N•m)
- △6 Apply semi-permanent anaerobic sealant
- △7 Torque to 4-5 in-lb (0.45-0.56 N•m)
- △8 Tighten cap (18) until it bottoms out
- △9 Used on non-circulating guns only

FIG. 14

Model 288554

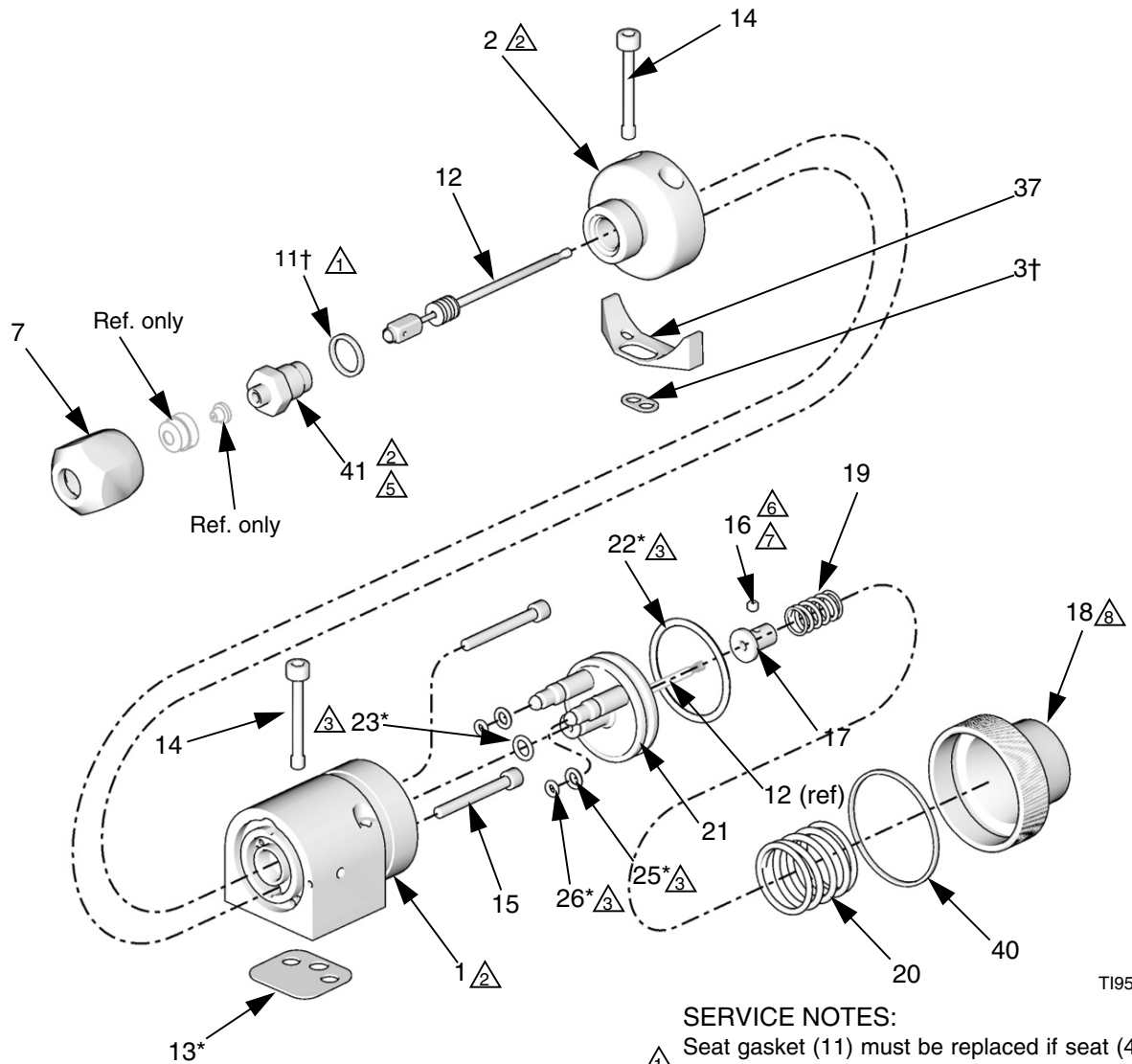

TI9523a

SERVICE NOTES:

- ⚠ Seat gasket (11) must be replaced if seat (41) is removed or replaced to avoid fluid leakage
- ② Lubricate threads with anti-seize lubricant
- ③ Lubricate with light-weight oil
- ④ Do not lubricate
- ⑤ Torque to 20-25 ft-lb (27-34 N•m)
- ⑥ Apply semi-permanent anaerobic sealant
- ⑦ Torque to 4-5 in-lb (0.45-0.56 N•m)
- ⑧ Tighten cap (18) until it bottoms out
- ⑨ Used on non-circulating guns only

FIG. 15

Parts

Ref. No.	Part No.	Description	Qty.	Ref. No.	Part No.	Description	Qty.
				19✓		SPRING, compression	1
					❖114138		
					◆120696		
1		BODY	1				
2		HOUSING, fluid	1	20✓	114139	SPRING, compression	1
3†★	288200	GASKET, fluid, acetal homopolymer, pack of 10	2	21	240895	PISTON, assy	1
4❖	192687	PLUG, fluid, internal, SST	1	22*	115066	PACKING, o-ring, fluoroelastomer	1
5†❖	114244	PACKING, o-ring, fluoroelastomer	1	23*	111450	PACKING, o-ring, fluoroelastomer	1
6†❖	114340	RING, back-up, PTFE	1	25*	112319	PACKING, o-ring, fluoroelastomer	2
7		NUT, retainer	1	26*	111504	PACKING, o-ring, fluoroelastomer	2
	❖171602			34	114141	WRENCH, hex (not shown)	1
	◆198391			37	15H702	INSERT, plastic	1
8	166969	GASKET, non-metallic	1	40◆	15K097	GASKET, piston cap	1
9✓❖	GG0xxx	TIP (see GG0 Series Tip Selection Charts , page 24)	1	41◆	233671	SEAT, airless	1
10✓❖	288196	DIFFUSER, seat, 3/16 in. ball	1				
11†	189970	GASKET, diffuser/valve	1				
12✓		NEEDLE, cartridge, assy.	1				
	❖288195						
	◆253886						
13*	114134	GASKET, polyethylene, bottom	1				
14	15H317	SCREW, mounting manifold (M5)	4				
15	15H318	SCREW, SHCS	2				
16	114137	SCREW, set, 6-32, 1/8 in. long	1				
17	192452	STOP, needle, SST	1				
18	192453	CAP, piston	1				

* Parts included in Air Seal Repair Kit 288171 (purchase separately). The kit includes some parts that are not used on this gun.

† Parts included in Fluid Seal Repair Kit 239896 (purchase separately).

★ An extra gasket (3) is included as a spare.

✓ Keep these spare parts on hand to reduce down time.

❖ Model 288048 only.

◆ Model 288554 only.

Part No. 241161
North America Manifold

Part No. 241162
International Manifold

Ref.

No.	Part No.	Description	Qty.
101	192441	MANIFOLD, air	1
102	192442	MANIFOLD, fluid	1
103	120388	FITTING, tube, air inlet; 1/4 in. OD tube x 1/8 npt(m)	1
105	114246	SCREW, set; 5/16;0.437 in. long	1
107	114342❖	ELBOW, fluid, male; 1/4 nptf(mbe); SST	2
	114247◆	ELBOW, fluid, male; #5 JIC x 1/4 - 18 npt	
109	101970	PLUG, pipe, SST; 1/4-18 ptf, supplied to plug fluid outlet port in non-circulating applications	3
110	120453	SCREW, M3 x 18	1

❖ Part No. 241161 only.

◆ Part No. 241162 only.

⚠ Apply anti-seize lubricant (222955) to threads and mating faces of manifold and any fittings and/or plugs used in fluid ports.

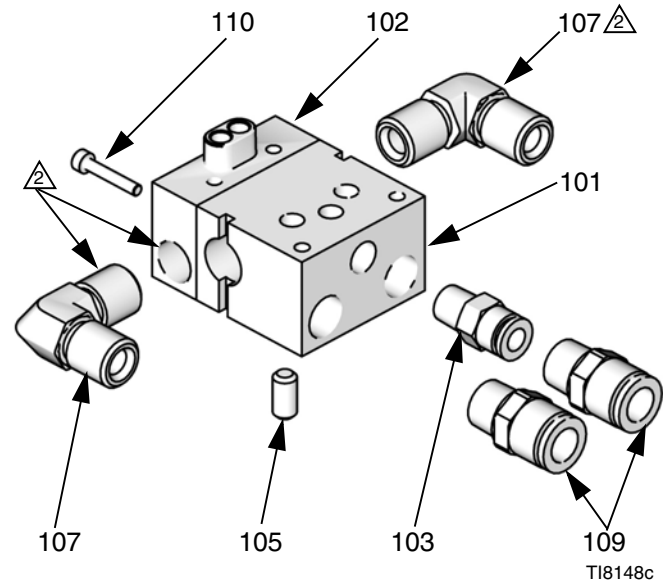

FIG. 16: North America and International Manifold

Part No. 244930

High Flow Ambient or Temperature Conditioned Manifold for streaming or spraying.

Ref.

No.	Part No.	Description	Qty.
201	198325	MANIFOLD, aluminum	1
202	110208	PLUG, 1/8 npt, SST	3

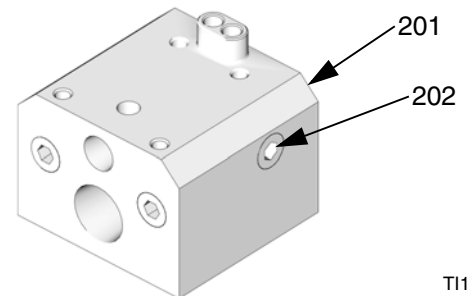

FIG. 17: Part No. 244930

GG0 Series Tip Selection Charts

GG0 Series Spray Tips

Orifice Size in. (mm)	* Fluid Output oz/min (lpm) at 600 psi (4.1 MPa, 41 bar)	Maximum Pattern Width at 12 in. (300 mm)								
		2 to 2.5 (50)	4 to 4.5 (100)	6 to 6.5 (150)	8 to 8.5 (200)	10 to 10.5 (250)	12 to 13 (300)	14 to 15 (350)	16 to 17 (400)	18 to 19 (450)
0.007 (0.178)	.053 (0.20)	107		307						
0.009 (0.229)	.087 (0.33)	109	209	309						
0.011 (0.279)	0.13 (0.49)	111	211	311	411	511	611			
0.013 (0.330)	0.18 (0.69)		213	313	413	513	613	713		
0.015 (0.381)	0.24 (0.91)	115	215	315	415	515	615	715	815	
0.017 (0.432)	0.31 (1.17)	117	217	317	417	517	617	717	817	917
0.019 (0.483)	0.39 (1.47)		219	319	419	519	619	719	819	
0.021 (0.533)	0.47 (1.79)		221	321	421	521	621	721	821	921
0.023 (0.584)	0.57 (2.15)			323	423	523	623	723	823	923
0.025 (0.635)	0.67 (2.54)			325	425	525	625	725	825	925
0.027 (0.686)	0.78 (2.96)			327	427	527	627	727	827	927
0.029 (0.737)	0.90 (3.42)				429	529	629	729		
0.031 (0.787)	1.03 (3.90)			331	431	531	631	731		931
0.033 (0.838)	1.17 (4.42)				433	533	633	733		
0.035 (0.889)	1.31 (4.98)			335	435	535	635	735		
0.037 (0.940)	1.47 (5.56)							737		
0.039 (0.991)	1.63 (6.18)					539	639			
0.041 (1.041)	1.80 (6.83)					541			841	
0.043 (1.092)	1.99 (7.51)					543	643			
0.045 (1.143)	2.17 (8.23)					545				
0.047 (1.197)	2.37 (8.98)					547		749		
0.049 (1.245)	2.58 (9.76)					553				
0.053 (1.35)	3.02 (11.4)						655			
0.055 (1.40)	3.25 (12.3)									

Sealer Application Tip and Air Cap Selection Charts

Shower Tip

No. of Orifices	Orifice Size <i>in. (mm)</i>	Part. No.
6	0.021 (0.533)	C08224

Streaming Tips

Orifice Size <i>in. (mm)</i>	Part. No.	Orifice Size <i>in. (mm)</i>	Part. No.
0.025 (0.635)	270025	0.039 (0.991)	270037
0.027 (0.686)	270027	0.041 (1.041)	270039
0.029 (0.736)	270029	0.043 (1.092)	270041
0.031 (0.787)	270031	0.045 (1.143)	270043
0.035 (0.889)	270035	0.057 (1.448)	270059

Single Orifice Fan Pattern Spray Tips

Orifice Size <i>in. (mm)</i>	Fan Width at 12 in. (300 mm) <i>in. (mm)</i>	Part No.
0.021 (0.533)	8-10 (200-250)	182421
	10-12 (250-300)	182521
	12-14 (300-350)	182621
	14-16 (350-400)	182721
	16-18 (400-460)	182821
0.023 (0.527)	8-10 (200-250)	182423
	10-12 (250-300)	182523
	12-14 (300-350)	182623
	14-16 (350-400)	182723
	16-18 (400-460)	182823
0.025 (0.635)	8-10 (200-250)	182425
	10-12 (250-300)	182525
	12-14 (300-350)	182625
	14-16 (350-400)	182725
	16-18 (400-460)	182825
0.027 (0.686)	8-10(200-250)	182427
	12-14 (300-350)	182627

Orifice Size <i>in. (mm)</i>	Fan Width at 12 in. (300 mm) <i>in. (mm)</i>	Part No.
0.029 (0.736)	8-10 (200-250)	182429
	12-14 (300-350)	182629
	16-18 (400-460)	182726
0.031 (0.787)	8-10 (200-250)	182431
	12-14 (300-350)	182631
	16-18 (400-460)	182831
0.035 (0.889)	8-10 (200-250)	182435
	10-12(250-300)	182535
	12-14 (300-350)	182635
0.039 (0.991)	8-10 (200-250)	182439
	10-12(250-300)	182539
	12-14 (300-350)	182639
0.043 (1.041)	8-10 (200-250)	182443
	10-12(250-300)	182543
	12-14 (300-350)	182643
	18-20 (450-500)	182643
0.047 (1.194)	18-20 (450-500)	182947

Accessories

Gun Manifolds

Order separately; not included with gun.
(See **Parts**, page 22.)

Part No. 241161
North America Manifold

Part No. 241162
International Manifold

Part No. 244930
High Flow Ambient or Temperature Conditioned Manifold for streaming or spraying.

Grounding Clamp and Wire 222011

High Pressure Ball Valves, Fluoroelastomer Seals

5000 psi (34 MPa, 345 bar) Maximum Working Pressure
Can be used as fluid drain valve.

Part No.	Description
210657	1/2 npt(m)
210658	3/8 npt(m)
210659	3/8 x 1/4 npt(m)

Bleed-type Master Air Valve

300 psi (2.1 MPa, 21 bar) Maximum Working Pressure
Relieves air trapped in the air line between the pump air inlet and this valve when closed.

Part No.	Description
107141	3/4 npt(m x f) inlet and outlet
107142	1/2 npt(m x f) inlet and outlet

Gasket Filter

Gasket filter 288201, package of 10. Small filter can be installed in the inlet gasket (3) for added filtration.

Tube Fittings for Air or Water

250 psi (1.7 MPa, 17 bar) Maximum Working Pressure
160° F (71° C) temperature rating

Part No.	Length
104172	1/8 npt(m) x 1/4 OD tube
597151	1/8 npt(m) x 1/4 OD tube, 90° elbow (swivel)

Brush 101892

For cleaning the gun.

In-line Fluid Filter 210500

5000 psi (35 MPa, 350 bar) Maximum Working Pressure

100 mesh. Fits onto the gun's fluid connector. 1/4-18 npsm. Includes the parts shown below.

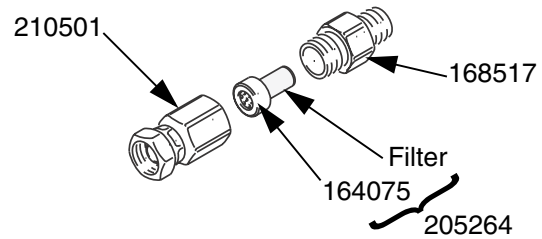

FIG. 18: In-line Fluid Filter

Needle/Diffuser Options

Needles must be used only with the specified seat to guarantee proper seating and life.

- Standard viscosity/standard flow
 - Fluid Needle 288195, 3/16 in. carbide ball
 - Seat 288196
- Acid catalyzed materials/very low viscosity materials
 - Fluid Needle 241468, 3/16 in. plastic ball
 - Seat 288196

Temperature Sensor and Cable

For temperature conditioned manifold

Part No.	Length
198457	RTD Sensor, 100 ohm, 1/8 npt(m) with 3 pin Picofast connector
198458	RTD cable, 6 ft. (1.83 m) Flex cable to St. Clair connector

Dimensions

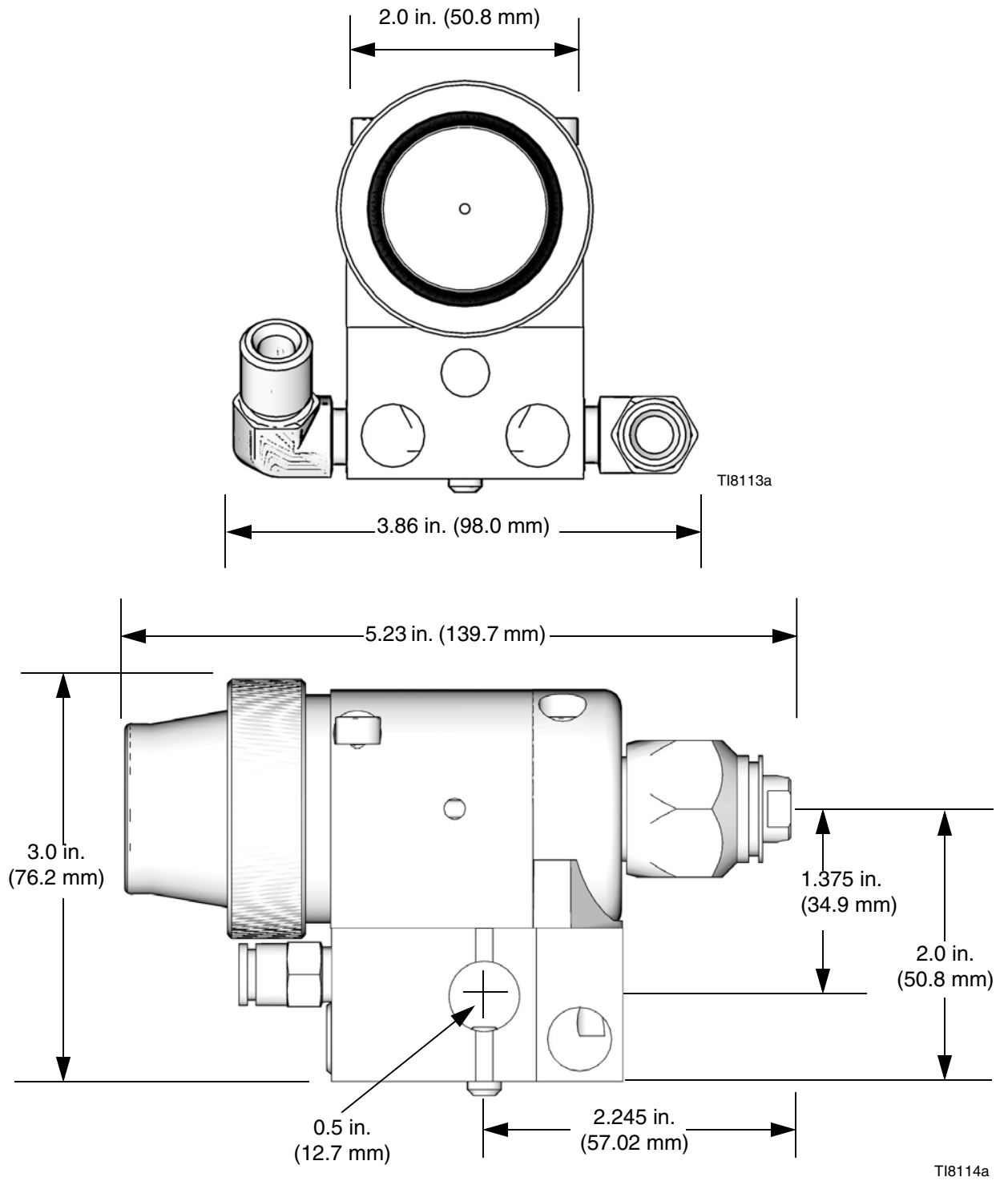

FIG. 19

Mounting Hole Layout

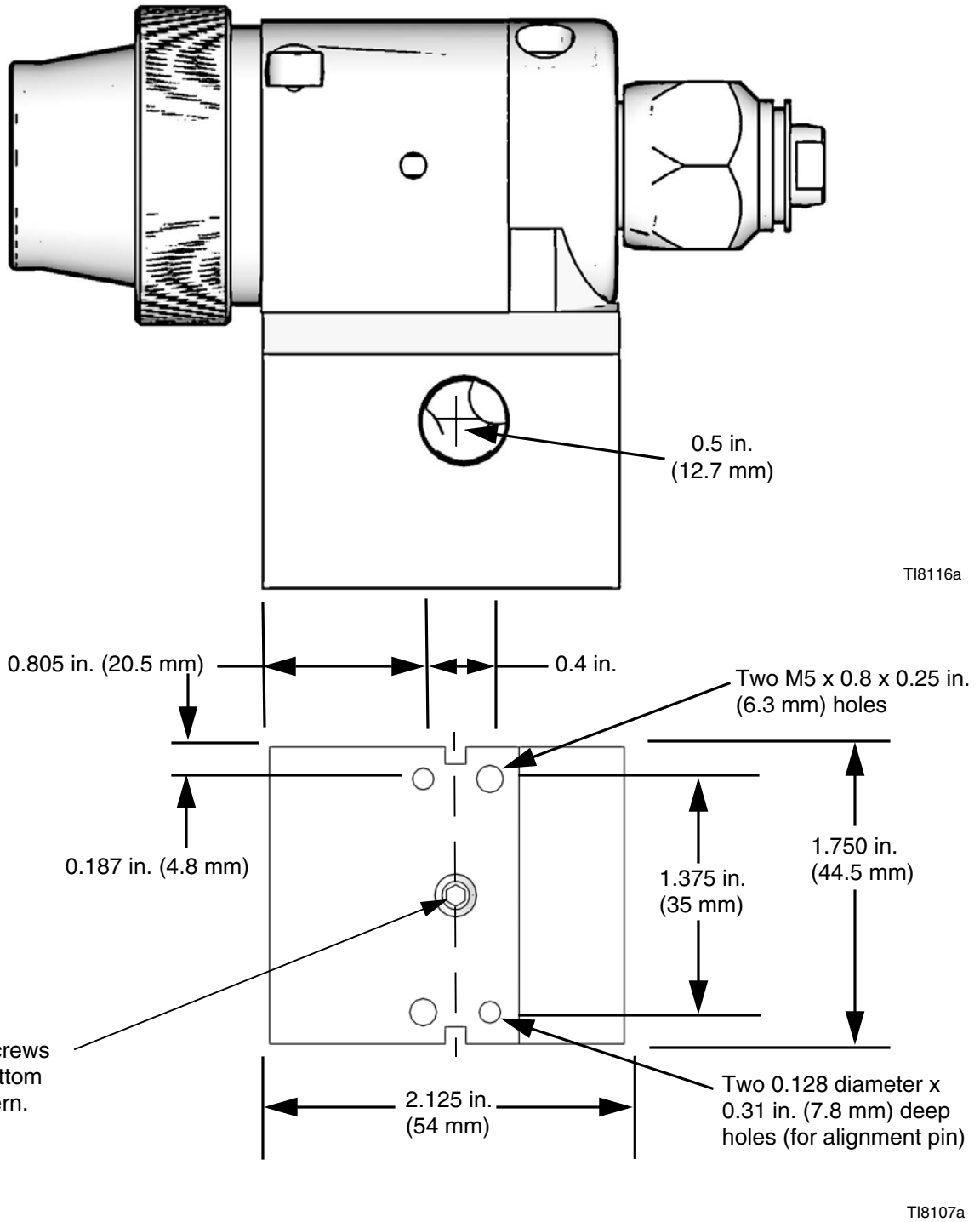

FIG. 20: Manifold Mounting Hole Layout

Technical Data

Maximum Working Fluid Pressure	4000 psi (28 MPa, 280 bar)
Maximum Working Air Pressure	100 psi (0.7 MPa, 7 bar)
Maximum Working Fluid Temperature	120° F (49° C): paint applications 140° F (60° C): non-flammable sealant applications
Minimum Air Cylinder Actuation Pressure	70 psi (0.49 MPa, 4.9 bar)
Weight	1.2 lbs (895 g)
Wetted Parts	Stainless Steel, Carbide, Ultra High Molecular Weight Polyethylene, Acetal, PEEK, Chemically Resistant Fluoro-elastomer, PTFE

Triggering Speed

These values apply to a new gun with a 6 ft (1.8 m), 1/4 in. (6.3 mm) OD cylinder air line and a 0.019 in. tip. These values will vary slightly with use and with variations in equipment.

Cylinder Air Pressure psi (kPa, bar)	Fluid Pressure psi (kPa, bar)	msec to fully open	msec to fully close
70 (0.49, 4.9)	600 (4.2, 42)	51	72
70 (0.49, 4.9)	1800 (12.4, 124)	56	73
70 (0.49, 4.9)	4000 (28, 280)	69	73

Sound Pressure Levels (dBa)

Sound pressure measured 3.28 ft (1 m) from equipment.

Input Fluid Pressures	
1500 psi (10.5 MPa, 105 bar)	4000 psi (28 MPa, 276 bar)
79.0 dB(A)	86.6 dB(A)

Sound Power Levels (dBa)

Sound power measured per ISO-9641-2.

Input Fluid Pressures	
1500 psi (10.5 MPa, 105 bar)	4000 psi (28 MPa, 276 bar)
75.7 dB(A)	86.3 dB(A)

Graco Standard Warranty

Graco warrants all equipment referenced in this document which is manufactured by Graco and bearing its name to be free from defects in material and workmanship on the date of sale to the original purchaser for use. With the exception of any special, extended, or limited warranty published by Graco, Graco will, for a period of twelve months from the date of sale, repair or replace any part of the equipment determined by Graco to be defective. This warranty applies only when the equipment is installed, operated and maintained in accordance with Graco's written recommendations.

This warranty does not cover, and Graco shall not be liable for general wear and tear, or any malfunction, damage or wear caused by faulty installation, misapplication, abrasion, corrosion, inadequate or improper maintenance, negligence, accident, tampering, or substitution of non-Graco component parts. Nor shall Graco be liable for malfunction, damage or wear caused by the incompatibility of Graco equipment with structures, accessories, equipment or materials not supplied by Graco, or the improper design, manufacture, installation, operation or maintenance of structures, accessories, equipment or materials not supplied by Graco.

This warranty is conditioned upon the prepaid return of the equipment claimed to be defective to an authorized Graco distributor for verification of the claimed defect. If the claimed defect is verified, Graco will repair or replace free of charge any defective parts. The equipment will be returned to the original purchaser transportation prepaid. If inspection of the equipment does not disclose any defect in material or workmanship, repairs will be made at a reasonable charge, which charges may include the costs of parts, labor, and transportation.

THIS WARRANTY IS EXCLUSIVE, AND IS IN LIEU OF ANY OTHER WARRANTIES, EXPRESS OR IMPLIED, INCLUDING BUT NOT LIMITED TO WARRANTY OF MERCHANTABILITY OR WARRANTY OF FITNESS FOR A PARTICULAR PURPOSE.

Graco's sole obligation and buyer's sole remedy for any breach of warranty shall be as set forth above. The buyer agrees that no other remedy (including, but not limited to, incidental or consequential damages for lost profits, lost sales, injury to person or property, or any other incidental or consequential loss) shall be available. Any action for breach of warranty must be brought within two (2) years of the date of sale.

GRACO MAKES NO WARRANTY, AND DISCLAIMS ALL IMPLIED WARRANTIES OF MERCHANTABILITY AND FITNESS FOR A PARTICULAR PURPOSE, IN CONNECTION WITH ACCESSORIES, EQUIPMENT, MATERIALS OR COMPONENTS SOLD BUT NOT MANUFACTURED BY GRACO. These items sold, but not manufactured by Graco (such as electric motors, switches, hose, etc.), are subject to the warranty, if any, of their manufacturer. Graco will provide purchaser with reasonable assistance in making any claim for breach of these warranties.

In no event will Graco be liable for indirect, incidental, special or consequential damages resulting from Graco supplying equipment hereunder, or the furnishing, performance, or use of any products or other goods sold hereto, whether due to a breach of contract, breach of warranty, the negligence of Graco, or otherwise.

FOR GRACO CANADA CUSTOMERS

The Parties acknowledge that they have required that the present document, as well as all documents, notices and legal proceedings entered into, given or instituted pursuant hereto or relating directly or indirectly hereto, be drawn up in English. Les parties reconnaissent avoir convenu que la rédaction du présente document sera en Anglais, ainsi que tous documents, avis et procédures judiciaires exécutés, donnés ou intentés, à la suite de ou en rapport, directement ou indirectement, avec les procédures concernées.

Graco Information

For the latest information about Graco products, visit www.graco.com.

TO PLACE AN ORDER, contact your Graco distributor or call to identify the nearest distributor.

Phone: 612-623-6928 or **Toll Free:** 1-800-533-9655, **Fax:** 612-378-3590

*All written and visual data contained in this document reflects the latest product information available at the time of publication.
Graco reserves the right to make changes at any time without notice.*

This manual contains English. MM 311053

Graco Headquarters: Minneapolis

International Offices: Belgium, China, Japan, Korea

GRACO INC. P.O. BOX 1441 MINNEAPOLIS, MN 55440-1441

Copyright 2006, Graco Inc. is registered to ISO 9001

www.graco.com

Revised 08/2009