

SNOOPER

SAFETY ALERT SYSTEMS

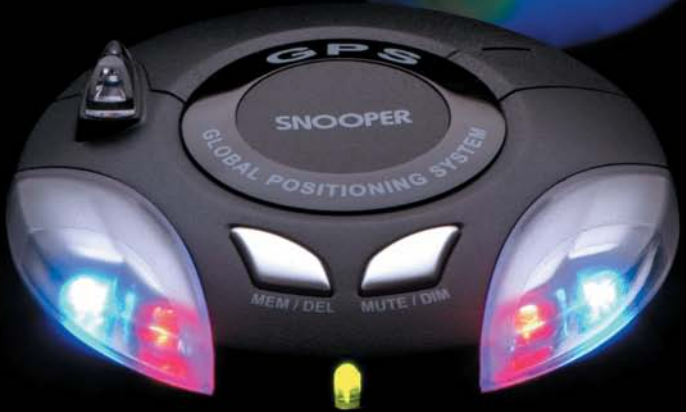
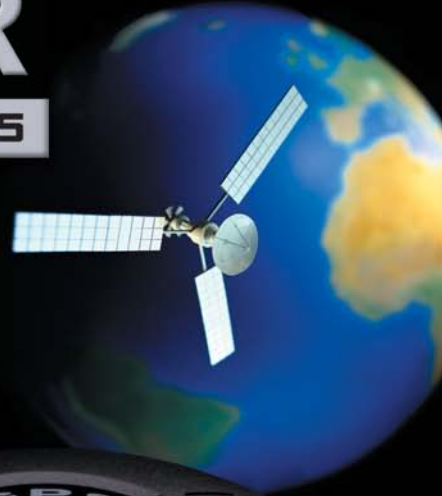

S2
neo

with built-in laser

USER MANUAL

[GO TO CONTENTS](#)

SNOOPER
SAFETY ALERT SYSTEMS

Drive
Safely with
a Snooper
GPS
system



Contents

CONTENTS

Page

- 3 Introduction
- 4 Components
- 5 Features
- 6 Registering and unlocking your S2
- 7 Downloading
- 8 Installation S2
- 13 Operating Instructions
- 13 Starting up
- 13 Mute button
- 13 Setting brightness
- 14 Adjusting the volume
- 14 Adding and deleting your own locations
- 15 Alert patterns
- 17 Troubleshooting
- 18 Specifications
- 18 Accessories & Price List
- 19 Service under Warranty

IMPORTANT - READ FIRST - IMPORTANT

Your Snooper S2 comes with a database of cameras pre-loaded. However you must register your S2 to receive an unlock code before you are able to use the device. Please note that the database on the device will have been downloaded at the time of production so may not be 100% accurate at the time of purchase. To ensure that your S2 works affectively we recommend that you download it as soon as possible after purchase.

See 'Registering your Snooper S2' for further details

Introduction

Congratulations on buying a Snooper Safety Alert System.

This user manual aims to provide you with installation and user instructions for the S2 neo GPS location device.

Utilising the very latest Global Positioning Satellite (GPS) technology, Snooper have created the S2 neo which has been specially designed to help you drive safely within the confines of today's speed limits, by alerting you quickly and easily to the presence of Police speed traps, often located at Accident Blackspots, electronically indicating potentially dangerous and hazardous situations.

The geographical co-ordinates of all 'fixed' speed monitoring systems and many officially designated accident 'hotspots' have been stored on a database that is constantly monitored and up-dated by our data collection team, ensuring that you are alerted to every potentially hazardous stretch of road or danger spot. The S2 connects quickly and easily to your PC so that you can download the database in a matter of minutes. Please note that a certain level of System Software is required on your PC, see the section on System Software in this manual for further details. Once the database has been downloaded your S2 compares your position using it's built-in GPS antenna, with the position of every known 'fixed' speed monitoring system and accident 'hotspot' alerting you both audibly and visually via a loud piezo beeper and a LED display ensuring your highest concentration at all times. In addition the S2 comes complete with a built-in laser detector, which has been designed to detect all types of laser speed monitoring systems often used in danger spots where 'Fixed' systems cannot be easily utilised, thus ensuring that you will be alerted to each and every speed monitoring system and accident hotspot whether Fixed or Mobile.

Drive Safely with Snooper!

The Snooper S2 has been designed and manufactured to help enhance road safety and is in no way a license to speed nor has it been designed as a substitute for concentration. Driving within the speed limit whilst carefully observing current road conditions is essential.

Components

S2 NEO

The following components come as standard with your Snooper S2 NEO:-

- 1 x S2 system
- 1 x Windscreen suction cup bracket
- 2 x Hook & loop fastener
- 1 x Coiled power lead with cigarette lighter socket adaptor
- 1 x 2m Straight hard wire lead
- 1 x USB - PC connecting cable
- 1 x CD Rom - Download Software & USB Driver



PLEASE NOTE

Due to our desire to continually improve our products specification may change without notice.

Features

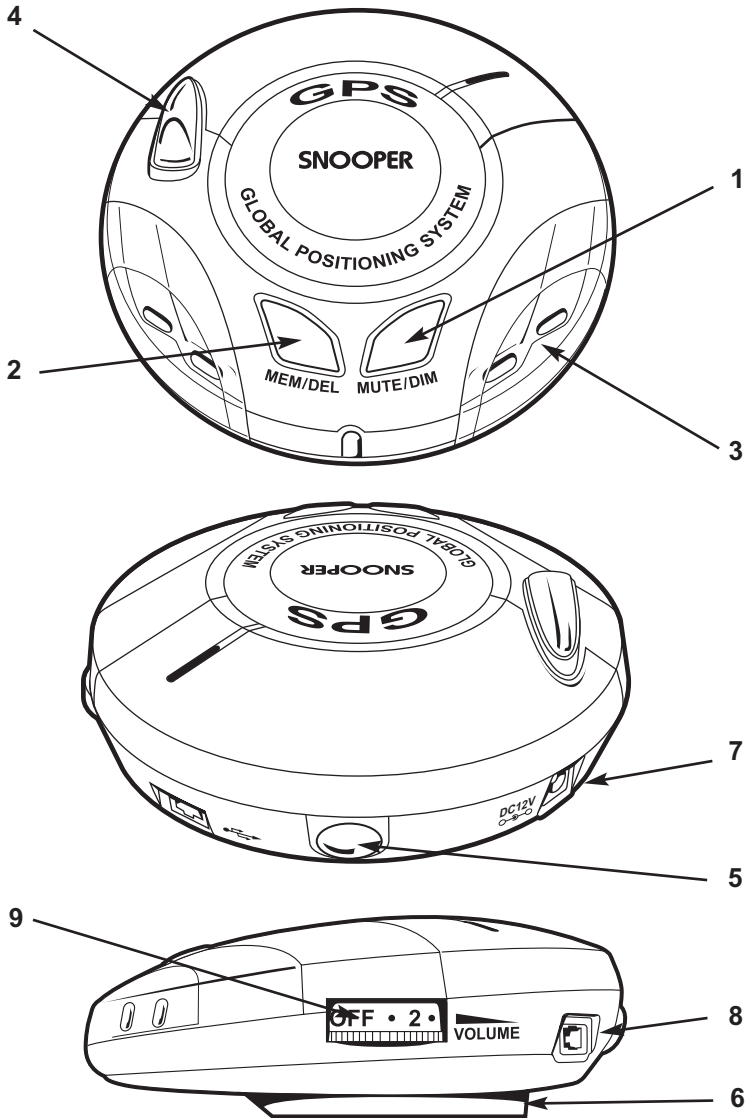

- | | |
|------------------------|---------------------------------|
| 1 Mute/Dim Button | 6 Bracket Mounting Slot |
| 2 Memory/Delete Button | 7 12v Power Input Socket |
| 3 LED Display | 8 USB Socket |
| 4 360° Laser Prism | 9 Power On/Off & Volume Control |
| 5 Rear Laser Sensor | |

Registration & Unlocking

IMPORTANT PLEASE READ BEFORE USING YOUR SNOOPER S2!

Registering your Snooper S2

The database built into your Snooper S2 is populated with the latest database available during production. However you will need to register your S2 to receive a unique unlock code before you can use the device. Please note that the database may not be 100% accurate due to the time elapsed between production and you receiving your S2. Therefore it is recommended that you perform a download as soon as possible to ensure that your S2 works as affectively as possible.

There are four ways of registering your unit as follows:-

Register On-line

Go to the official Snooper website www.s2neo.co.uk and register on-line. Your unit should be activated and your unlock code supplied within one hour of registration.

By Telephone

Contact us by telephone on 0870 787 0700. Your unit should be activated and your unlock code supplied within 1 hour of registration.

By Fax or Post

Fill out the registration form included with your S2 and fax it to 0870 787 1700. Your unit should be activated within 1 hour.

If you would like to register by post send the completed registration form to us at:-

**Performance Products Ltd
Clever House, Sarus Court, Manor Park, Runcorn, WA7 1UL**

If you register by post your unit should be activated within 24 hours of our receipt of your completed registration form.

If you register by post or fax please indicate how you would like us to supply your unlock code i.e. by return fax or post and the details where you would like it sending.

Unlocking your Snooper S2

After you have registered your unit you will be supplied with a unique unlock code. You then need to enter the number into your device using the following method:-

For example if your unlock code is 48.

1. Power up your S2 whilst holding down the MUTE/DIM button. This will put the S2 into the unlock mode.
2. As the unlock code is 48, you need to first enter the number 4 and then the number 8. Therefore press the MEM/DEL button 4 times and then press the MUTE/DIM button to confirm the entry. Next press the MEM/DEL button 8 times and again press the MUTE/DIM button to confirm the entry.

If your S2 is locked the two outer red LED's will flash every 3 seconds. Once you have successfully entered the two digits your S2 will enter the standby mode with the central red LED flashing every second to indicate it is searching for satellite lock.

Downloading

Performing a download is simple but first of all you will have to install the downloading and USB driver software on to your PC by using the CD Rom included with this product.

Installing the S2 Download & USB Driver Software

Put the CD into an available CD drive and double click on the PP S2 Set Up icon and follow the on screen instructions.

Once the the S2 download and USB driver software has been installed, double click on the S2 download software icon that should now have appeared on your desk top and follow the on-screen instructions carefully. Connect the USB cable to a spare comport on your computer, connecting the opposite end of the lead to the USB socket marked on your S2. Next switch your S2 on by turning the on/off volume control towards you. Follow the on-screen instructions until you reach the screen featuring the 'Start Update' button and click on it to begin the download procedure. The download will run automatically whilst the PC on-screen display will keep you informed of it's progress.

As there are constant additions to our location database you will need to perform regular downloads. The frequency with which you do this is entirely up to you, but we recommend that higher mileage drivers often driving on unfamiliar roads, download once or twice a week whereas lower mileage drivers perform a download once or twice a month.

Please note that you will need to register your Snooper S2 before you can perform any downloads.

Having problems?

If you find you are having problems either installing the S2 download software or downloading your S2, please visit www.snooperneo.co.uk and click on 'Troubleshooting' where the latest Help information can be found. Also check the 'Download Software' section on the same site as there may be a more recent, improved version of the S2 download software available which may solve any problems you are currently experiencing.

Installation

Once you have performed a download it is time to install the Snooper S2 into your vehicle. The most important aspects of this installation are ensuring that the Snooper S2 is positioned in such a way that it has a clear view of the sky whilst ensuring that the device is situated so that it does not interfere with the vehicles controls and does not jeopardise either the passengers or drivers safety.

For best results mount the S2 on to the vehicles dashboard so that the top of the unit has a clear view of the sky. Some vehicles including Renault, Citroen and Peugeot may come with a 'Heat reflective' or 'Comfort' front windscreen which may affect the performance of the built-in GPS antenna, although the S2 will work effectively in vehicles with a 'heated' windscreen. In these situations you will need to purchase a re-radiating antenna which can be positioned on the rear parcel shelf. Contact Performance Products or your local dealer for further information. In both cases the unit or extension antenna should be positioned so that it has a clear view of the sky directly above. When positioning your Snooper S2 ensure that it is located in such a way that you can easily view the LED display without having to take your eyes from the road ahead and so that you can reach the controls safely.

Please also be aware that you will need to be able to remove the device to perform downloads. Once you have found a suitable location for your S2 secure it in place with the 'Hook and loop' fastener or suction cup bracket provided, remembering to clean the area where the fastener or bracket is going to be positioned thoroughly before hand to ensure a good contact.

More in depth mounting instructions are provided below.

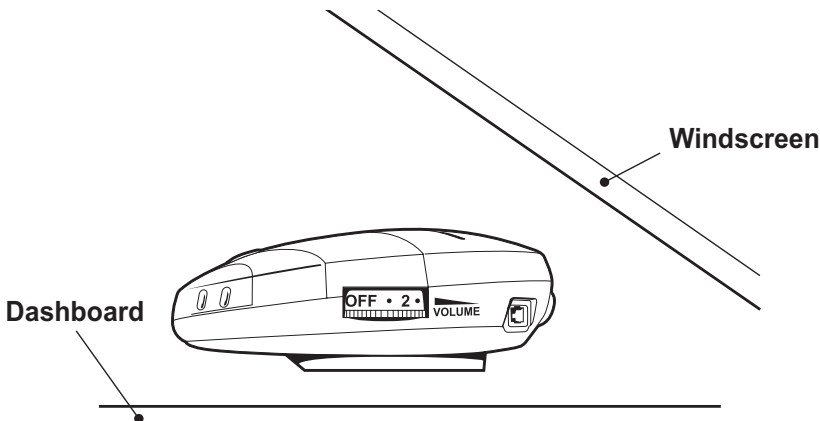

PLEASE NOTE: Be careful to choose a location that does not block the drivers view or where it might endanger the driver or passengers should your vehicle suddenly come to a stop or be involved in an accident.

Installing your Snooper S2 using the Hook and Loop fastener

The Snooper S2 can be installed anywhere on the dashboard as long as the built-in GPS antenna has a clear view of the sky and you can easily see the LED display and operate the controls safely. You will also need to be sure that you can connect the power connection cable. Your S2 can be installed easily with the hook and loop fastener if you have a sufficiently flat area on your dashboard. Follow these instructions to mount the control panel in this way.

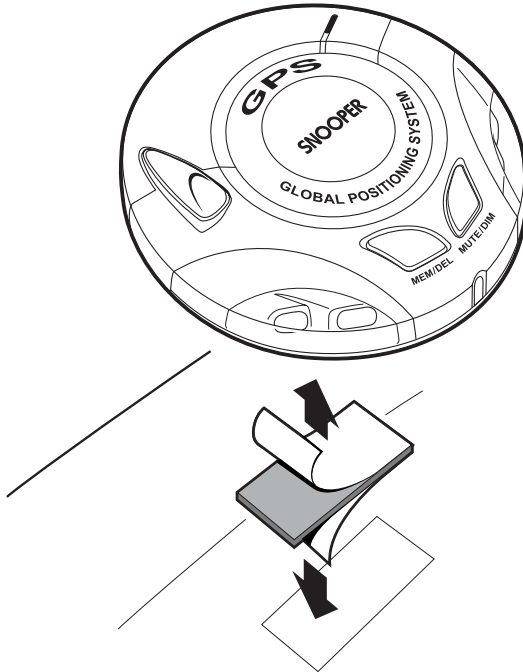

- Use a damp cloth to thoroughly clean the bottom of the S2 and the area where you intend to mount your unit.
- With the two parts of the Hook and Loop fastener still fastened together, peel the backing tape from the softer 'Loop' side of the fastener and apply it to the bottom of the unit.
- Next remove the backing tape from the 'Hook' side of the fastener, again whilst the two parts are still fastened and position the unit onto the desired area. If possible leave the Hook and Loop fastener for 24hrs to adhere properly before using regularly.
- Finally plug the smaller plug on one end of the power cable into the socket marked DC12V on the back of the S2 and plug the larger plug into the cigarette lighter socket of your vehicle. Your Snooper S2 is now ready for use. For further information please read the section on Power Connection on page 10.

Installing your Snooper S2 using the Windscreen Suction Cup bracket

If you prefer you can mount your S2 to the inside of your vehicles windscreen using the suction cup bracket provided. Simply select a position within the windscreen so that the top of the unit has a clear view of the sky, remembering that you need to connect the power connection cable as well as ensuring that you can read the LED display and reach the controls safely.

Follow these instructions to mount the unit in this way

- Install the suction cups onto the bracket by fitting them into it's holes.
- Clean the area where you wish to position the bracket thoroughly with a good quality glass cleaner.
- Carefully bend the bracket so that when it is mounted on to the windscreen with the S2 attached, the Control Panel is facing in the desired direction so that you can easily see the LED display and safely operate the controls.
- Slide the S2 onto the bracket until it is secure and the unit is positioned in as horizontal a position as possible.
- To remove the S2 simply slide the unit off the bracket from the front.

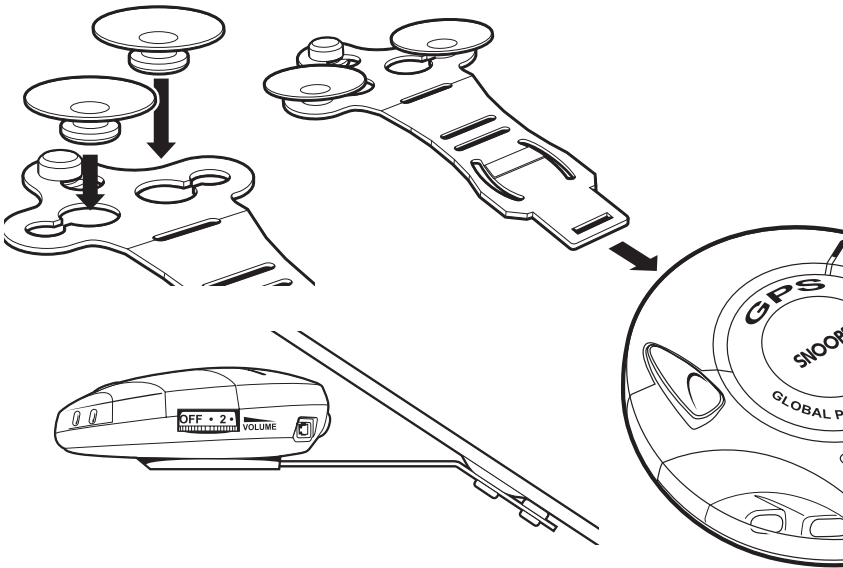

- Finally plug the smaller plug on one end of the power cable into the socket marked DC12V on the back of the S2 and plug the larger plug into the cigarette lighter socket of your vehicle. Your Snooper S2 is now ready for use. For further information please read the section on Power Connection on page 11.

Power Connection

Using the cigarette lighter socket

The S2 comes with a power cable designed to plug into your vehicles cigarette lighter socket. Take the lead and plug the smaller end into the DC 12v input socket on the back of the S2 and the cigarette lighter adaptor in your vehicles cigarette lighter socket.

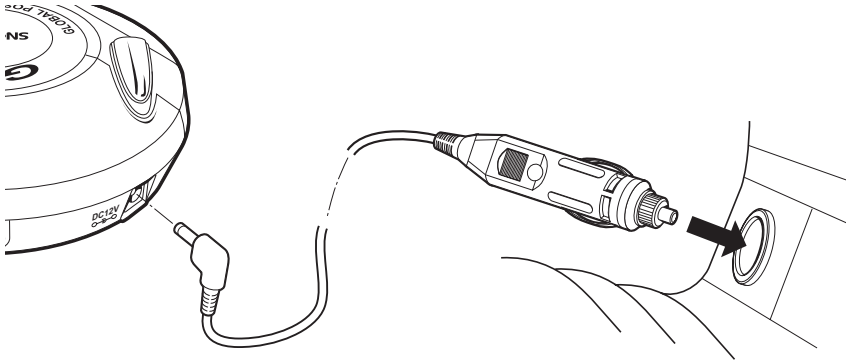

Please Note: Do not leave your S2 plugged into the cigarette lighter socket when you start your vehicle. The cigarette lighter socket is prone to power surges when the vehicle is started that may damage your unit. If the device does not power up please check that the cigarette lighter socket is clean of any debris, remembering not to insert any metal objects into the socket, check that the cigarette lighter adaptor is inserted all the way into the socket and to check that the fuse in the cigarette lighter adaptor is operational. If your S2 will still not power up, please check that the cigarette lighter in your vehicle is functioning correctly.

Replacing the Fuse

If the detector stops operating, the fuse in the cigarette lighter plug might be blown. If it has blown, follow these steps to replace it with a 2 amp, 5 x 20mm, fast acting fuse.

Caution: Using a fuse that does not meet these ratings or defeating fuse protection can damage your detector, the power cable, or the vehicles electrical system.

1. Grasp the ring near the tip of the cigarette lighter plug, then carefully unscrew the ring by turning it counterclockwise.

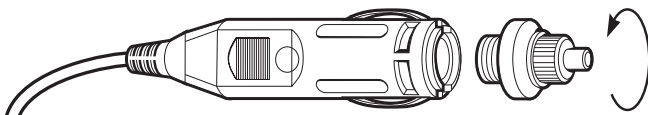

Caution: If you must use pliers to loosen the ring, be careful not to crush the tip. Never use pliers or other tools to retighten the ring on the cigarette lighter plug.

2. Pull the ring straight out, then remove the metal tip, spring and old fuse.

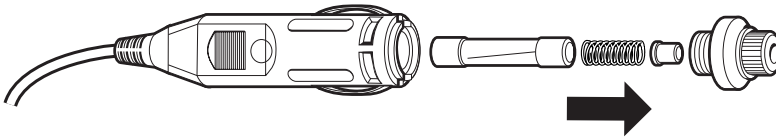

3. Check the fuse to see if it has blown. If it has, replace it.

4. Replace the metal tip and spring inside the ring, then place the fuse inside the cigarette lighter plug and screw the ring back onto the plug. Make sure the metal tip is visible when you reassemble the cigarette lighter plug.

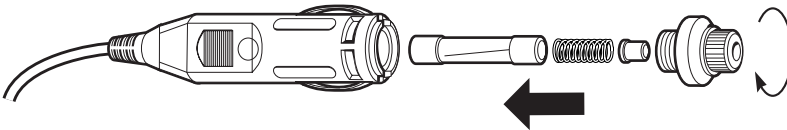

Direct connecting/hard wiring your S2 neo

You can power your Snooper S2 by wiring it directly to your vehicles 12v electrical system using the 'Hard Wire' cable supplied as standard with your unit. Firstly connect the positive side of the cable (Red) to a 12v switched live. This is a live that is On when the ignition is On and Off when the ignition is Off. The negative side of the lead should be connected to a negative ground, so can be attached to any metal portion of the vehicles frame. Next plug the small adaptor on the other end of the lead into the DC 12V input socket on the back of the unit.

Important: If you are unfamiliar with this procedure, please consult a professional auto electrician

Operating Instructions

Starting Up

After you have successfully installed your S2 it is time to perform the first start up. Firstly make sure your vehicle is parked in as open a space as possible, clear of tall trees and buildings so that the built-in GPS antenna has a clear view of the sky above. Next power the unit up by turning the on/off/volume towards you. The S2 will go through a brief self test procedure and the central red LED will then flash indicating that the unit is searching for satellite connection. The S2 needs to acquire a minimum of 4 satellites to work effectively, once this has been achieved the LED will turn green and will stop flashing. Once the solid green LED is displayed your S2 is ready for use and will now automatically alert you of any locations stored in it's database as well as laser alerts.

As the GPS engine and antenna have never been used before, the first 'Cold' start up could take somewhere between 5 - 30mins. Once initialised, subsequent start ups will take as little as 3 mins.

1. Mute Button

If during an alert you decide that you would like to mute it, simply press the 'Mute' button briefly. The LED s will continue to display a visual alert but no sound will be heard. After you have travelled out of range of the location the device will automatically reset so that next time you encounter a location you will receive both audible and visual alerts as normal.

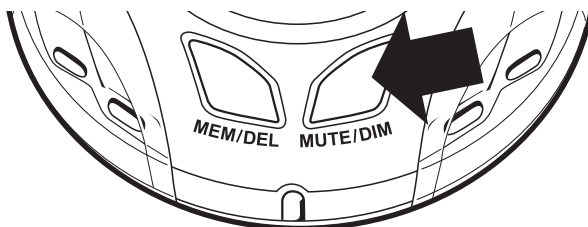

2. Setting Brightness

You can adjust the brightness of the display on your S2 by pressing the MUTE/DIM button when the unit is not detecting or locating a signal. There are 2 levels of brightness to choose from bright or dimmed.

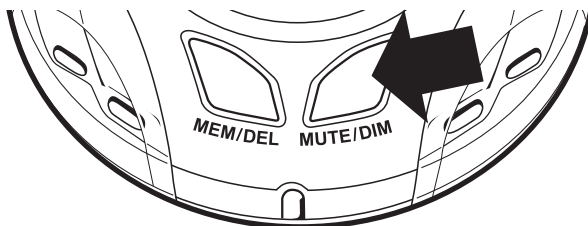

3. Adjusting the volume

The S2 has an adjustable volume for controlling the loudness of the audible alert. To increase the volume simply turn the volume control on the right hand side of the device, towards you. To decrease the volume of the alert turn the volume control away from you.

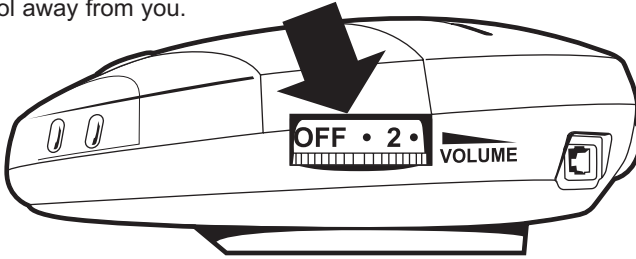

4. Adding your own locations

It is possible to add your own personal locations to your Snooper S2. To add a new location make sure you are stationary and parked in a safe, legal manner then press the 'MEM/DEL' button (see below) for approximately 2 seconds. It is possible to store up to 99 of your own co-ordinates. When your S2 detects one of your own co-ordinates the led display and bleeper will alert you in the normal way at pre-set distance of 300m.

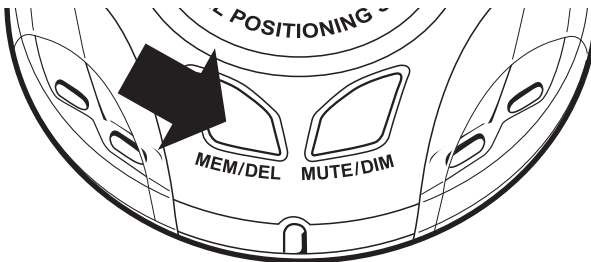

5. Deleting your own locations

There are two ways to delete locations you have saved and stored yourself. You can delete them independently by pressing and holding the MEM/DEL button for approximately 2 seconds whilst you are at that particular location and receiving a User Saved alert. Secondly you can delete all your saved locations at the same time by pressing and holding the MEM/DEL button and the MUTE/DIM button together as you power the unit up. Finally power your s2 off and then on again Once a user location has been deleted it cannot be recovered except by re-plotting it.

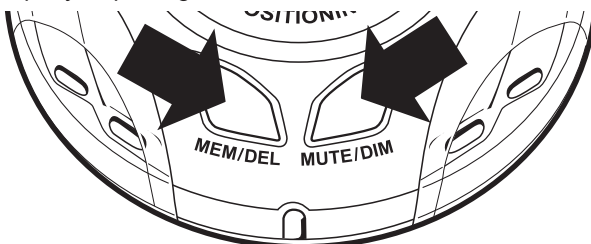

6. Alert Patterns

Laser Alerts

The S2 incorporates a built-in laser detector. As laser often requires instant action the device simply gives you a loud audible alert whilst the display will flash all 4 LED's simultaneously.

If you would like to Mute a Laser alert, simply press the 'Mute' button at any time during the alarm.

Gatso & Truvelo Safety Cameras

As you approach the Safety Camera the unit will begin to emit an audible alert and as you get closer to the camera the 'Beeping' will quicken. There are 2 different tones, one to indicate that you are above the posted speed limit and one to indicate you are below it. At the same time the display will flash either the two red LED's if you are above the posted speed limit or the two blue LED's if you are below the posted speed limit. Please note that this is just a guide and you should ensure you are aware of the speed limit at all times.

If you would like to change the alert to a visual alert only press the 'Mute' button during the alert to temporarily turn off the sound.

SPECs Safety Camera Systems

Due to the fact that the SPECs camera incorporates a series of cameras that monitor you over a fixed distance, a different alert pattern has been devised to ensure that your concentration is maintained throughout the danger zone. If you are approaching the first camera in the SPECs system your S2 will begin it's alert at 500m and will begin to beep. Once you have passed the camera the unit will then emit an audible alert every five seconds to remind you that you are still within the SPECs system. If after 20 seconds you do not pass another camera, for instance if you have turned off the motorway without passing the last camera in the SPECs series the alert will automatically 'Time out' and the alert will finish. Whilst travelling through a SPECs system however, your Snooper S2 will provide both an audible and visual alert 250m before each camera plus will alert every 5 seconds between them until you reach the last camera in the SPECs sequence.

Please note that if you join a road in the middle of a SPECs system you will automatically get a visual and audible alert, 250m before the first camera that you pass.

If you would like to change the alert to a visual alert only press the 'Mute' button during the alert to temporarily turn off the sound .

Auto mute

please note that after 5 seconds the audible alert will automatically be reduced to approximately half volume

7. Autorange & Pre-Alert

The S2 incorporates a new feature called Autorange. Autorange simply selects the correct alert distance to each camera detected depending on the speed limit of the road the camera is situated on. The different alert distances are shown below.

Detection distances for High Risk Zones, Gatso & Truvelo Cameras

Speed Limit	Pre-Alert
20 or 30mph	200m
40mph	250m
50mph	300m
60mph	400m
70mph	500m

SPECs: When locating a SPECs camera system the S2 will give 500m warning of the first camera and then 250m of every other camera in the sequence.

User Saved Co-ordinates. The S2 will automatically give you 300m advanced warning of any User Saved Co-ordinates in it's memory.

Please Note - Your Snooper S2 will give a visual warning only, if you are travelling below 10mph.

Troubleshooting

The unit cannot be switched on

Check that the cigarette lighter adaptor is well inserted into the cigarette lighter socket and that the cigarette light socket is functioning properly. Check that the lighter socket is clean and free from debris. Also check that the fuse in the cigarette lighter adaptor is functioning correctly. If you are using the hardwire connection check that you have secured a good earth and that you have taken the 12v feed from a 12v supply that is live on ignition. Also check that the in-line fuse is operating correctly.

The unit cannot acquire satellites

Check that the S2's built-in GPS antenna has a clear view of the sky above. If this is the first time you have powered up your Snooper S2 please remember that the first 'cold' start may take between 15-30 minutes to acquire sufficient satellites for operation. Disconnect and re-connect the power to the unit and start the power up procedure again.

The satellite signal temporarily or permanently drops out

This may happen temporarily in areas where there are a significant number of tall buildings or trees or whilst driving through a tunnel. The signal should only be lost for a few seconds and quickly reacquired. Check that the device has not moved and that the built-in GPS antenna still has a good clear view of the sky above. Very occasionally you may experience bad satellite coverage that may lead to you losing a signal. This should last no longer than a few short minutes.

The device does not appear to respond to Police speed monitoring systems

Have you performed a download recently? If not perform a fresh download to ensure that you have all the latest co-ordinates stored on your device.

Specification

Dimensions

Width - 90mm
Depth - 90mm
Height - 33mm

Laser

Optical 360 degree sensor
Receiver Type - Pulsed Laser Signal receiver
Detector Type - Digital Signal Processed Pulse Width Discriminator
Opto Sensor - High Speed Photo Diode Detector
Spectral Response - 800 - 1,100nm

GPS

Receiving Method - 12 Channels parallel
Receiving Frequency - 1575.42Mhz +/- 1Mhz, C/A code
Cold Start - 15mins(Typ) At normal temperature
Warm Start - 45secs(Typ) At normal temperature
Hot Start - 15secs(Typ) At normal temperature

Snooper Accessories & Price List

The following accessories are available from your local Snooper dealer.
For further details please contact our technical help line on 0870 787 0700.

Remote GPS re-radiating extension antenna.....	£69.95
Coiled power lead with cigarette lighter adaptor.....	£12.95
2m Straight power lead with cigarette lighter adaptor.....	£12.95
2m Straight hard wire lead.....	£12.95
Windscreen mounting bracket.....	£12.95
Hook & loop fastener.....	£2.95
USB- PC connection lead.....	£12.95
1-3 Lighter socket extension.....	£7.95
25ml anti-static LCD display cleaner & protector.....	£7.95
12v power supply.....	£12.95

Service Under Warranty

- 1 To obtain service during the two year warranty period, return your unit, postage paid by Special Delivery and in suitable packaging to:

**Performance Products Ltd,
Clever House,
Sarus Court,
Manor Park,
Runcorn,
WA7 1UL**

**Tel: 0870 787 0700
Fax: 0870 787 1700**

- 2 Enclose the following information:
 - (a) Your name, return address and description of the problem.
 - (b) A telephone number where you can be reached during business hours.
 - (c) Proof of purchase.

SNOOPER

SAFETY ALERT SYSTEMS



PERFORMANCEPRODUCTS

Cleaver House, Sarus Court,
Stuart Road, Manor Park, Runcorn WA7 1UL
Tel: 0870 78 70 700 Fax: 0870 78 71 700
www.performanceproducts.co.uk