

# PRO-FORM<sup>®</sup>

## 1195 ZLT

### USER'S MANUAL

Model No. PETL84909.0

Serial No. \_\_\_\_\_

Write the serial number in the space above for reference.

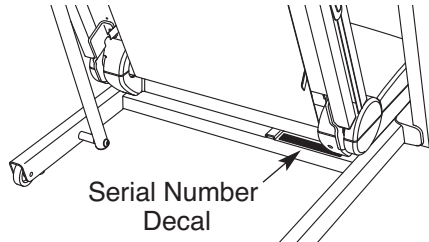

### QUESTIONS?

If you have questions, or if there are missing parts, please contact us:

Call: 08457 089 009

From Ireland: 053 92 36102

E-mail: Visit [www.iconsupport.eu](http://www.iconsupport.eu)

Write:

ICON Health & Fitness, Ltd.  
c/o HI Group PLC, Express Way  
Whitwood, West Yorkshire  
WF10 5QJ  
UK

In Australia:

Please contact the store where you purchased this product.

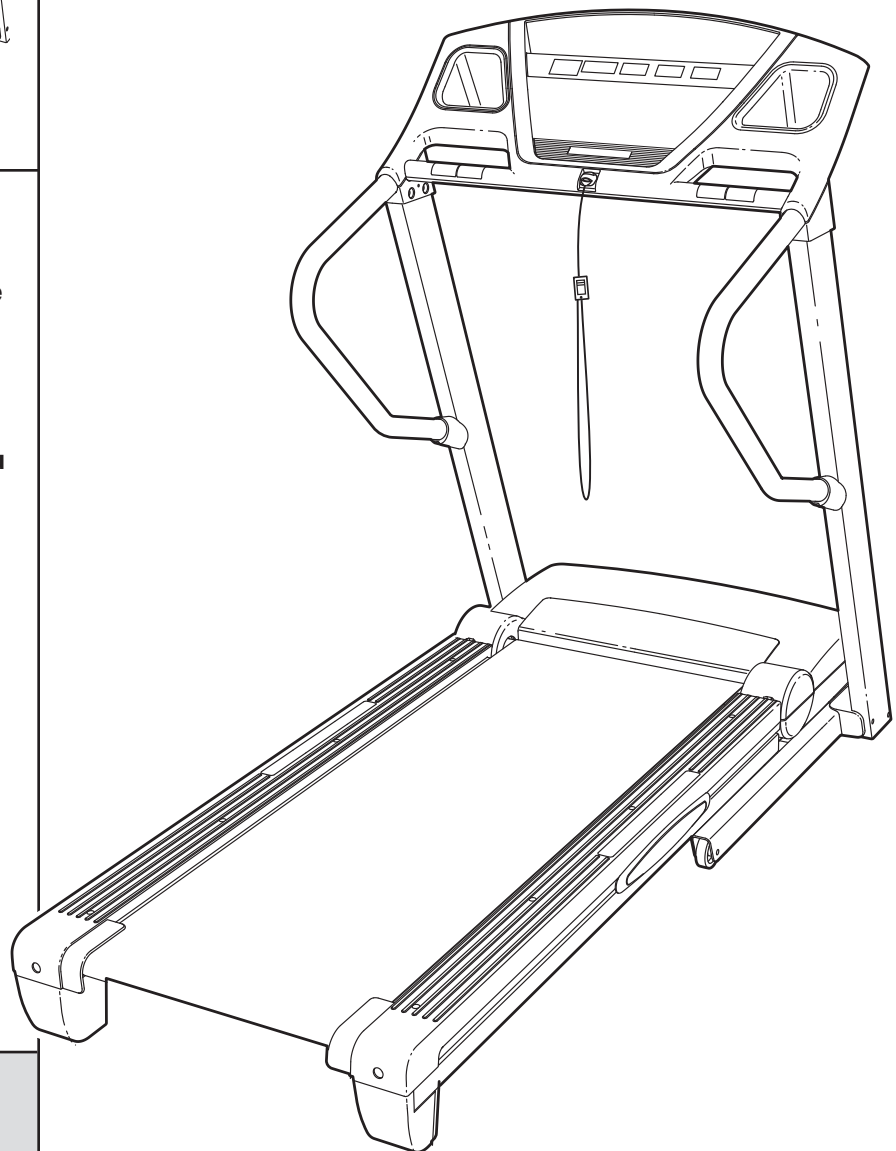

### ⚠ CAUTION

Read all precautions and instructions in this manual before using this equipment. Save this manual for future reference.

# TABLE OF CONTENTS



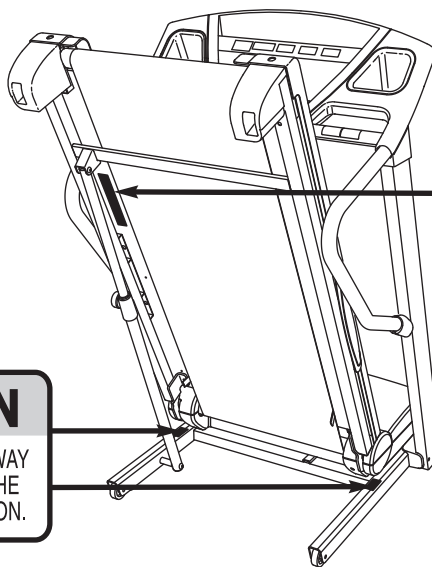

WARNING DECAL PLACEMENT .....	.2
IMPORTANT PRECAUTIONS .....	.3
BEFORE YOU BEGIN .....	.5
ASSEMBLY .....	.6
OPERATION AND ADJUSTMENT .....	.14
HOW TO FOLD AND MOVE THE TREADMILL .....	.20
TROUBLESHOOTING .....	.22
EXERCISE GUIDELINES .....	.25
PART LIST .....	.26
EXPLODED DRAWING .....	.28
ORDERING REPLACEMENT PARTS .....	.Back Cover
RECYCLING INFORMATION .....	.Back Cover

## WARNING DECAL PLACEMENT

This drawing shows the locations of the warning decals. **If a decal is missing or illegible, call the telephone number on the front cover of this manual and request a free replacement decal. Apply the decal in the location shown.** Note: The decals may not be shown at actual size.



**▲WARNING:**  
Protect yourself and others from risk of serious injury. Read the user's manual and :

-  •Stand only on the side rails when starting or stopping treadmill.
- Change speed in small increments.
- Hold handrails to prevent falling, and always wear the safety clip while operating treadmill.
- Stop if you feel faint, dizzy, or short of breath.
- Fully engage storage latch before treadmill is moved or stored.
- Reduce incline to its lowest level before folding treadmill into storage position.
-  •Never allow children on or around treadmill.
- Remove key when not in use.
-  •Keep clothing, fingers, and hair away from moving belt.
- Never try to adjust or fix the belt while it is moving.
-  •Always wear athletic shoes while operating treadmill.

# IMPORTANT PRECAUTIONS

**⚠ WARNING:** To reduce the risk of serious injury, read all important precautions and instructions in this manual and all warnings on your treadmill before using your treadmill. ICON assumes no responsibility for personal injury or property damage sustained by or through the use of this product.

1. Before beginning any exercise program, consult your physician. This is especially important for persons over age 35 or persons with pre-existing health problems.
2. It is the responsibility of the owner to ensure that all users of this treadmill are adequately informed of all warnings and precautions.
3. Use the treadmill only as described.
4. Place the treadmill on a level surface, with at least 8 ft. (2.4 m) of clearance behind it and 2 ft. (0.6 m) on each side. Do not place the treadmill on any surface that blocks air openings. To protect the floor or carpet from damage, place a mat under the treadmill.
5. Keep the treadmill indoors, away from moisture and dust. Do not put the treadmill in a garage or covered patio, or near water.
6. Do not operate the treadmill where aerosol products are used or where oxygen is being administered.
7. Keep children under age 12 and pets away from the treadmill at all times.
8. The treadmill should be used only by persons weighing 300 lbs. (136 kg) or less.
9. Never allow more than one person on the treadmill at a time.
10. Wear appropriate exercise clothes when using the treadmill. Do not wear loose clothes that could become caught in the treadmill. Athletic support clothes are recommended for both men and women. *Always wear athletic shoes. Never use the treadmill with bare feet, wearing only stockings, or in sandals.*
11. When connecting the power cord (see page 14), plug the power cord into an earthed circuit. No other appliance should be on the same circuit. When replacing the fuse in the power cord adapter, insert an ASTA-approved BS1362, 13-amp fuse into the fuse carrier.
12. If an extension cord is needed, use only a 3-conductor, 14-gauge (1 mm<sup>2</sup>) cord that is no longer than 5 ft. (1.5 m).
13. Keep the power cord away from heated surfaces.
14. Never move the walking belt while the power is turned off. Do not operate the treadmill if the power cord or plug is damaged, or if the treadmill is not working properly. (See TROUBLESHOOTING on page 22 if the treadmill is not working properly.)
15. Read, understand, and test the emergency stop procedure before using the treadmill (see HOW TO TURN ON THE POWER on page 16).
16. Never start the treadmill while you are standing on the walking belt. Always hold the handrails while using the treadmill.
17. The treadmill is capable of high speeds. Adjust the speed in small increments to avoid sudden jumps in speed.
18. The pulse sensor is not a medical device. Various factors, including the user's movement, may affect the accuracy of heart rate readings. The pulse sensor is intended only as an exercise aid in determining heart rate trends in general.

19. Never leave the treadmill unattended while it is running. Always remove the key, unplug the power cord, and switch the reset/off circuit breaker to the off position when the treadmill is not in use. (See the drawing on page 5 for the location of the circuit breaker.)
20. Do not attempt to raise, lower, or move the treadmill until it is properly assembled. (See ASSEMBLY on page 6, and HOW TO FOLD AND MOVE THE TREADMILL on page 20.) You must be able to safely lift 45 lbs. (20 kg) to raise, lower, or move the treadmill.
21. When folding or moving the treadmill, make sure that the storage latch is holding the frame securely in the storage position.
22. Never insert any object into any opening on the treadmill.
23. Inspect and properly tighten all parts of the treadmill regularly.
24. **DANGER:** Always unplug the power cord immediately after use, before cleaning the treadmill, and before performing the maintenance and adjustment procedures described in this manual. Never remove the motor hood unless instructed to do so by an authorized service representative. Servicing other than the procedures in this manual should be performed by an authorized service representative only.
25. This treadmill is intended for in-home use only. Do not use this treadmill in a commercial, rental, or institutional setting.
26. Over exercising may result in serious injury or death. If you feel faint or if you experience pain while exercising, stop immediately and cool down.

**SAVE THESE INSTRUCTIONS**

# BEFORE YOU BEGIN

Thank you for selecting the revolutionary PROFORM® 1195 ZLT treadmill. The 1195 ZLT treadmill offers an impressive selection of features designed to make your workouts at home more enjoyable and effective. And when you're not exercising, the unique treadmill can be folded up, requiring less than half the floor space of other treadmills.

**For your benefit, read this manual carefully before using the treadmill.** If you have questions after read-

ing this manual, please see the front cover of this manual. To help us assist you, please note the product model number and serial number before contacting us. The model number and the location of the serial number decal are shown on the front cover of this manual.

Before reading further, please review the drawing below and familiarize yourself with the labeled parts.

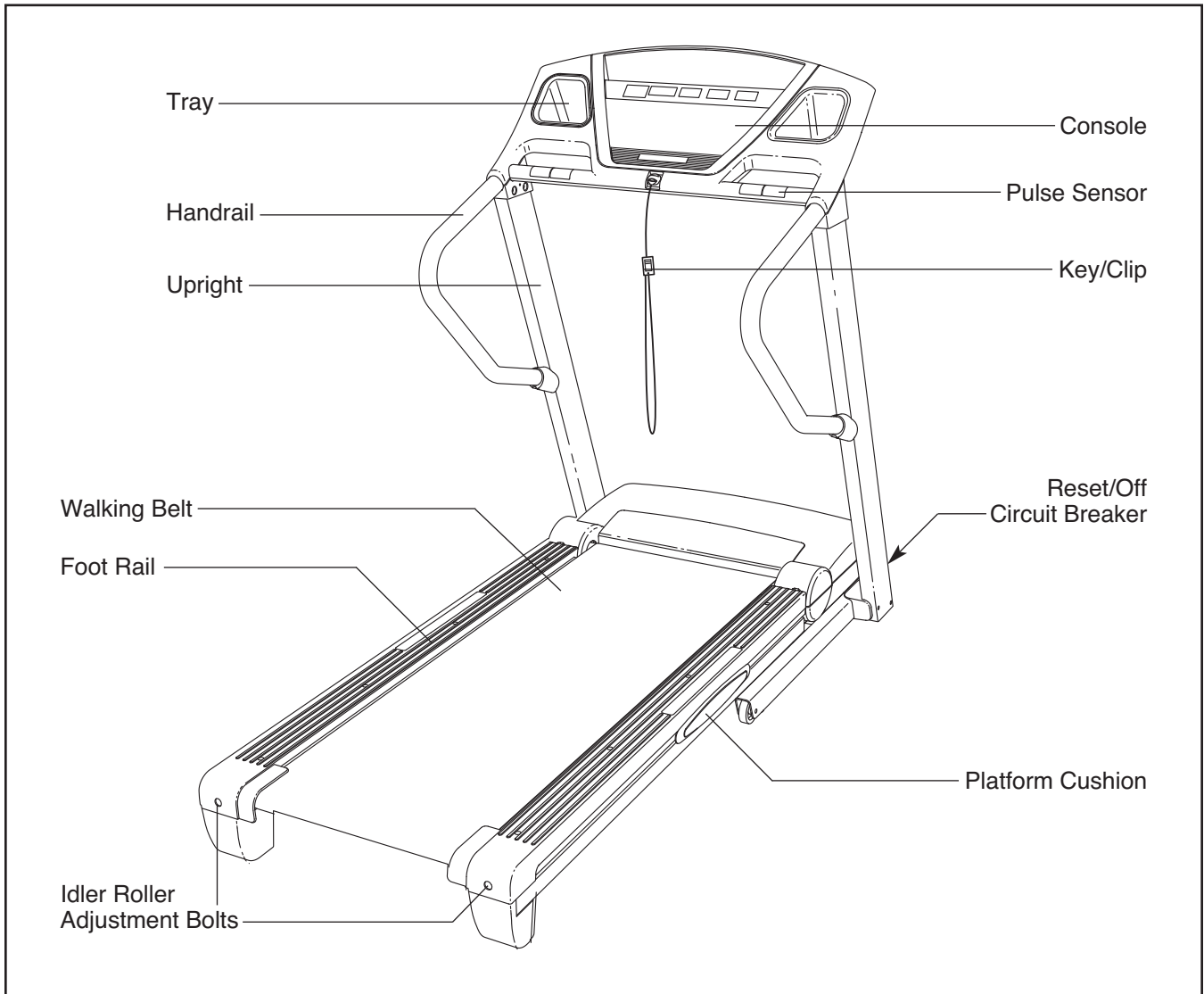

# ASSEMBLY

**Assembly requires two persons.** Set the treadmill in a cleared area and remove all packing materials. **Do not dispose of the packing materials until assembly is completed.** Note: The underside of the treadmill walking belt is coated with high-performance lubricant. During shipping, some lubricant may be transferred to the top of the walking belt or the shipping carton. This is normal and does not affect treadmill performance. If there is lubricant on top of the walking belt, simply wipe off the lubricant with a soft cloth and a mild, non-abrasive cleaner.

**Assembly requires the included hex keys  and your own Phillips screwdriver , adjustable wrench , needlenose pliers , and scissors .**

Use the drawings below to identify the assembly hardware. The number in parentheses below each drawing is the key number of the part, from the PART LIST near the end of this manual. The number after the parentheses is the quantity needed for assembly. **Note: If a part is not in the hardware kit, check to see if it is preattached to one of the parts to be assembled. To avoid damaging plastic parts, do not use power tools for assembly. Extra hardware may be included.**

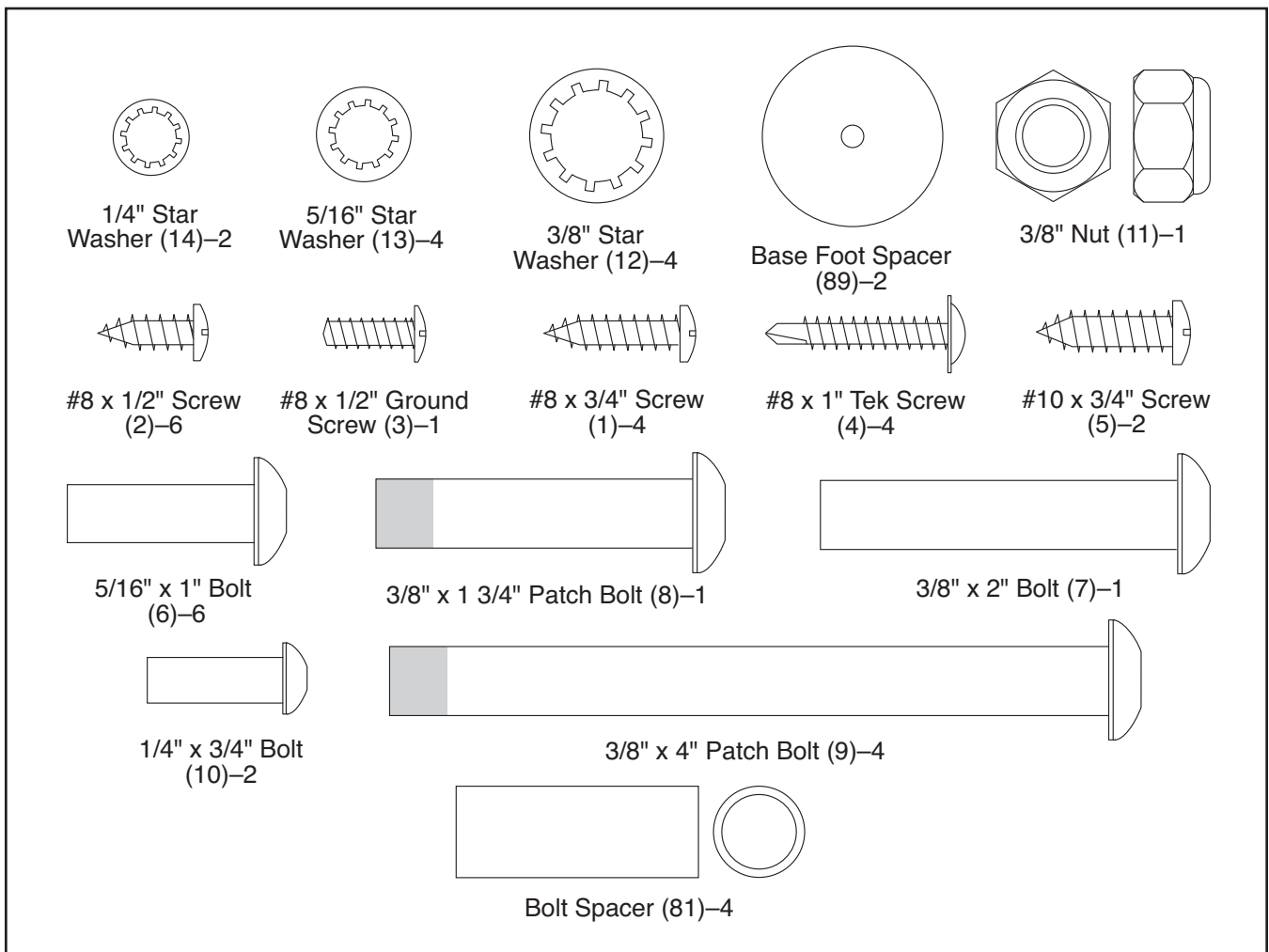

1. **Make sure that the power cord is unplugged.**

Remove the 3/8" Nut (11), the 3/8" x 2" Bolt (7), and the shipping bracket (C) from the Base (87). Remove the shipping bracket from the other side of the treadmill. Discard the shipping brackets. **Save the Nuts and the Bolts for steps 3 and 6.**

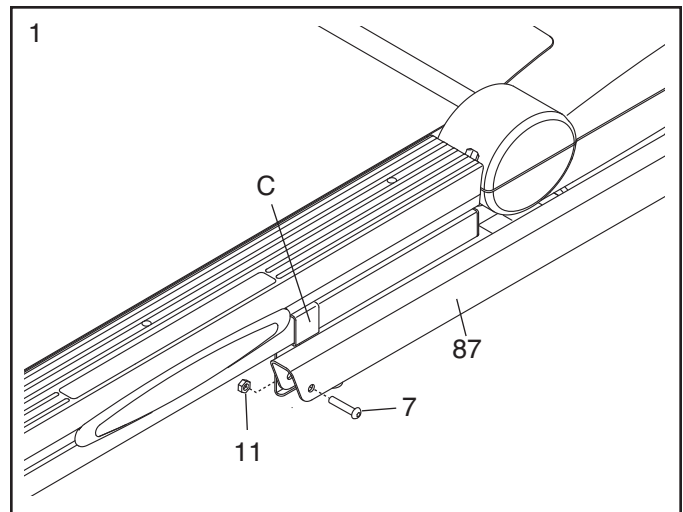

2. With the help of a second person, carefully tip the treadmill onto its left side. Partially fold the Frame (51) so that the treadmill is more stable; **do not fully fold the Frame yet.**

Remove and discard the indicated bolts (A) and the shipping bracket (B).

Cut the shipping tie securing the Upright Wire (79) to the Base (87). Locate the plastic tie in the indicated hole in the Base, and use the tie to pull the Upright Wire out of the hole.

Attach two Base Feet (84) to the Base (87) in the locations shown with two #8 x 1" Tek Screws (4) and two Base Foot Spacers (89).

Then, attach the other two Base Feet (84) with two #8 x 1" Tek Screws (4).

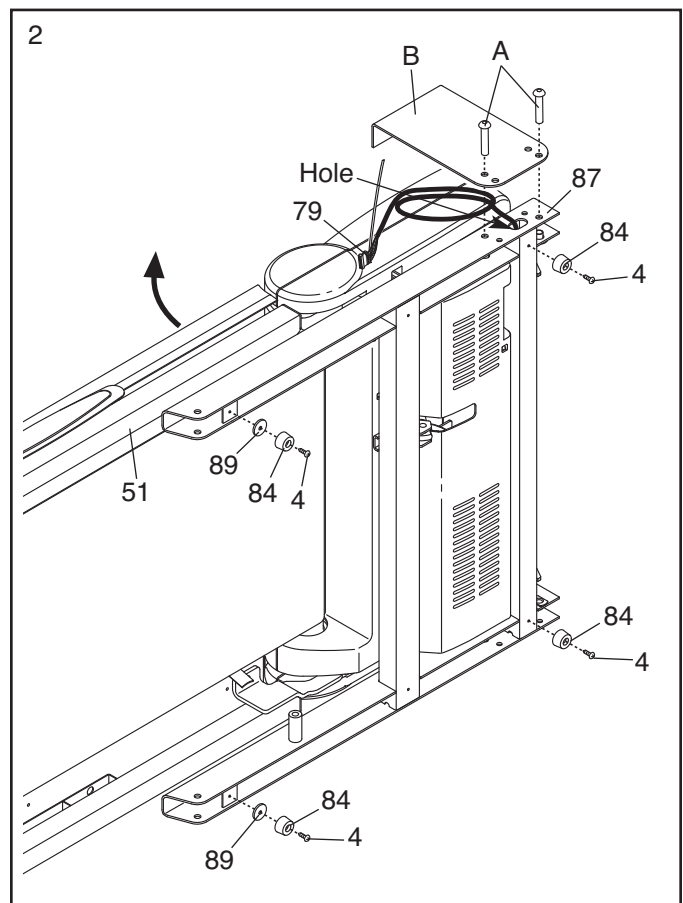

- Attach a Wheel (88) to the Base (87) with a 3/8" x 2" Bolt (7) and a 3/8" Nut (11). **Do not over-tighten the Nut; the Wheel must turn freely.**

Press a Base Cap (83) into the Base (87).

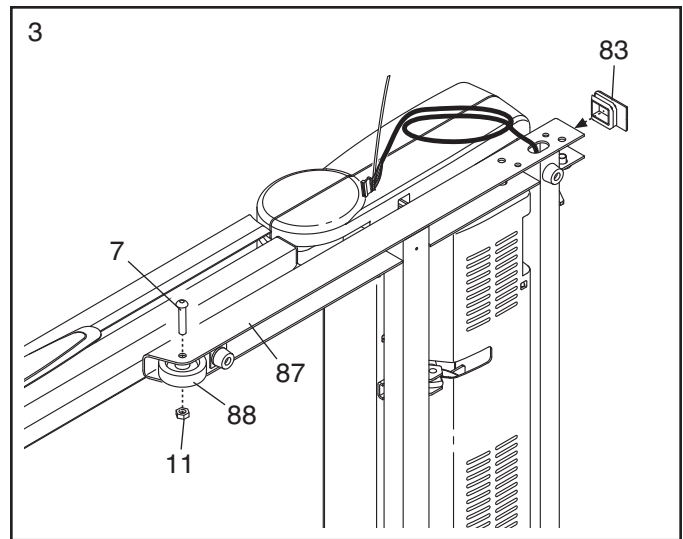

- Identify the Right Upright (80) and the Right Upright Spacer (82), which are marked with "Right" stickers.

Insert the Upright Wire (79) through the Right Upright Spacer (82) as shown. Set the Right Upright Spacer on the Base (87).

Have a second person hold the Right Upright (80) near the Base (87). **See the inset drawing.** Tie the wire tie in the Right Upright securely around the end of the Upright Wire (79). Then, pull the other end of the wire tie until the Upright Wire is routed completely through the Right Upright.

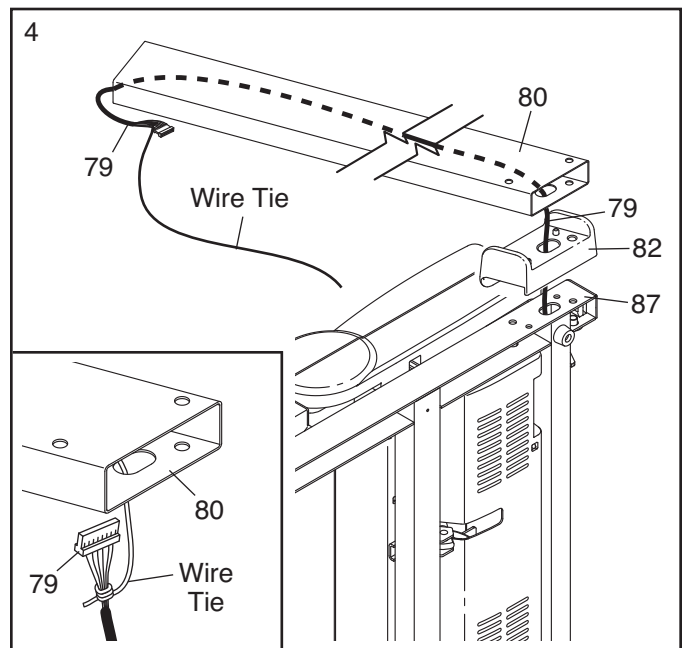

- Hold a Bolt Spacer (81) inside the lower end of the Right Upright (80). Insert a 3/8" x 4" Patch Bolt (9) with a 3/8" Star Washer (12) into the Right Upright and the Bolt Spacer. **Repeat this step with a second Bolt Spacer (81), 3/8" x 4" Patch Bolt (9), and 3/8" Star Washer (12).**

Hold the Right Upright (80) against the Right Upright Spacer (82). **Be careful not to pinch the Upright Wire (79).** Tighten the 3/8" x 4" Patch Bolts (9) until the heads of the Patch Bolts touch the Upright; **do not fully tighten the Patch Bolts yet.**

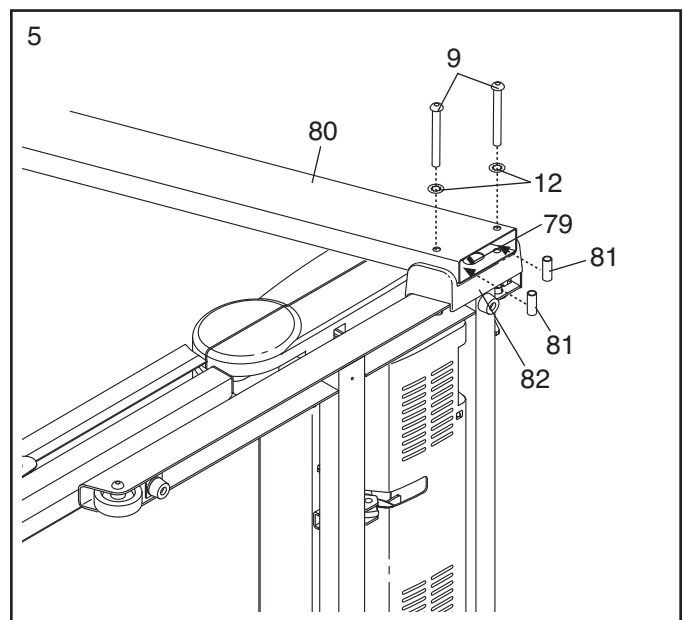



6. With the help of a second person, carefully tip the treadmill onto its right side. Partially fold the Frame (51) so that the treadmill is more stable; **do not fully fold the Frame yet.**

Remove and discard the indicated bolts (A) and the shipping bracket (B).

Attach a Wheel (88) to the Base (87) with a  $\frac{3}{8}$ " x 2" Bolt (7) and a  $\frac{3}{8}$ " Nut (11). **Do not over-tighten the Nut; the Wheel must turn freely.**

Press a Base Cap (83) into the Base (87).

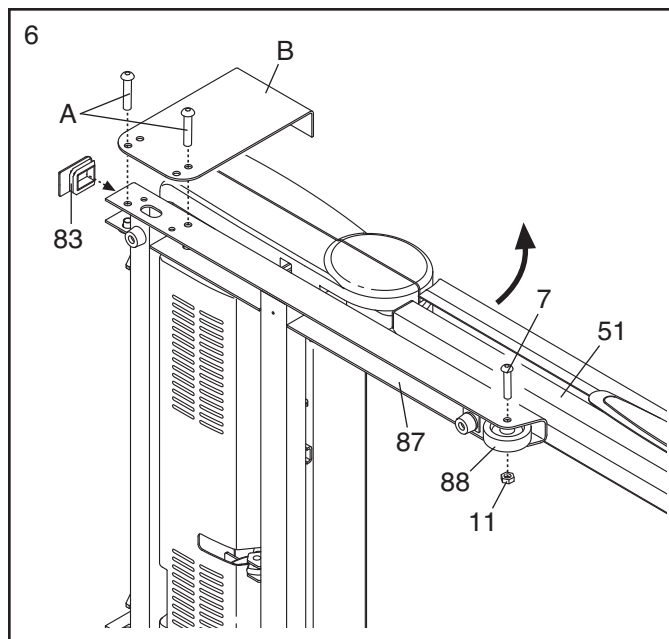

7. Hold a Bolt Spacer (81) inside the lower end of the Left Upright (75). Insert a  $\frac{3}{8}$ " x 4" Patch Bolt (9) with a  $\frac{3}{8}$ " Star Washer (12) into the Left Upright and the Bolt Spacer. **Repeat this step with a second Bolt Spacer (81),  $\frac{3}{8}$ " x 4" Patch Bolt (9), and  $\frac{3}{8}$ " Star Washer (12).**

Hold the Left Upright Spacer (86) and the Left Upright (75) against the Base (87). Tighten the  $\frac{3}{8}$ " x 4" Patch Bolts (9) until the heads of the Patch Bolts touch the Upright; **do not fully tighten the Patch Bolts yet.**

With the help of a second person, tip the treadmill so that the Base (87) is flat on the floor.

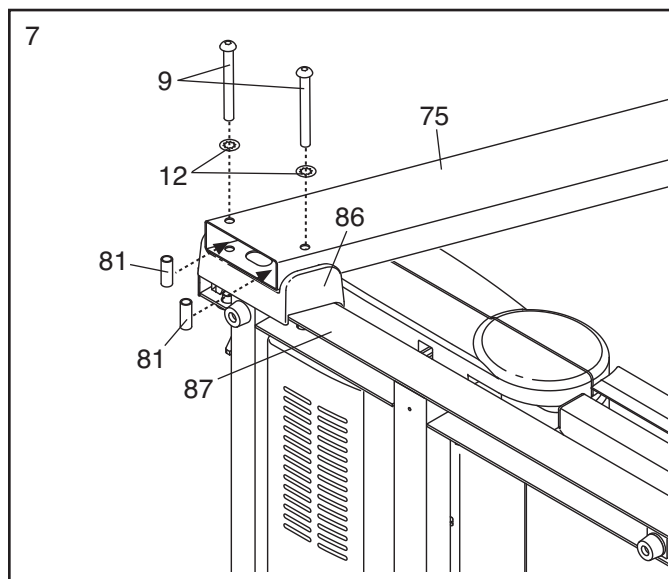

8. Slide the Left Handrail Spacer (74) and the Right Handrail Spacer (78) onto the top of the Left Upright (75) and the Right Upright (80).

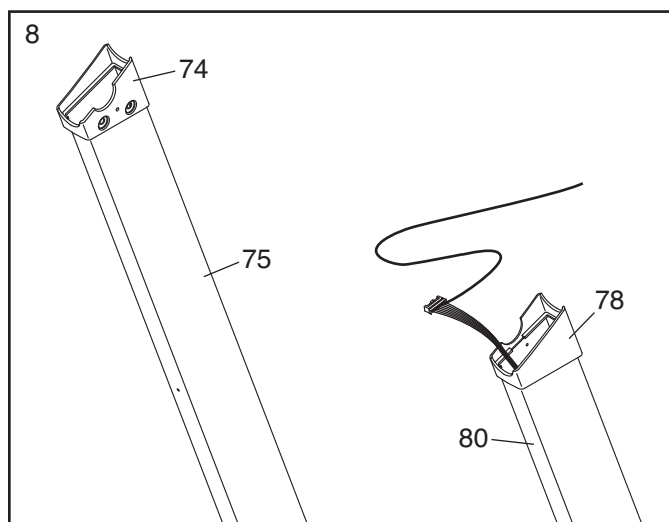

9. Insert the end of the Upright Wire (79) into the bottom of the Right Handrail (104) and pull it out of the hole in the side of the Right Handrail.

Slide the Handrail Caps (105) onto the lower ends of the Right Handrail (104) and the Left Handrail (107). Then, insert the brackets on the Handrails into the tops of the Uprights (75, 80).

Remove the wire tie from the Upright Wire (79).

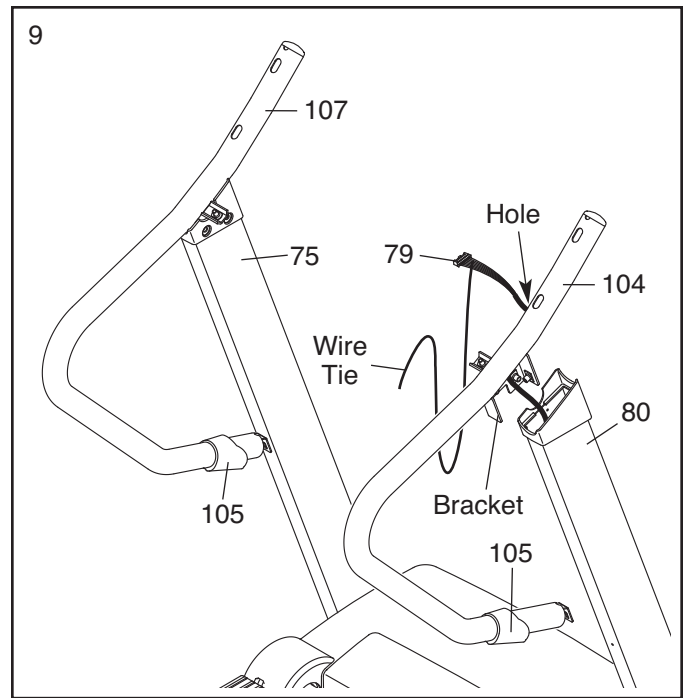

10. Attach the Right Handrail (104) and the Left Handrail (107) with six 5/16" x 1" Bolts (6) and four 5/16" Star Washers (13) as shown. **Do not fully tighten the Bolts yet.**

Slide the Handrail Caps (105) away from the Uprights (75, 80). Attach the lower end of each Handrail (104, 107) to the Upright with a #10 x 3/4" Screw (5).

Orient the Handrail Caps (105) as shown. Attach a Handrail Cap to each Handrail (104, 107) with a #8 x 1/2" Screw (2).

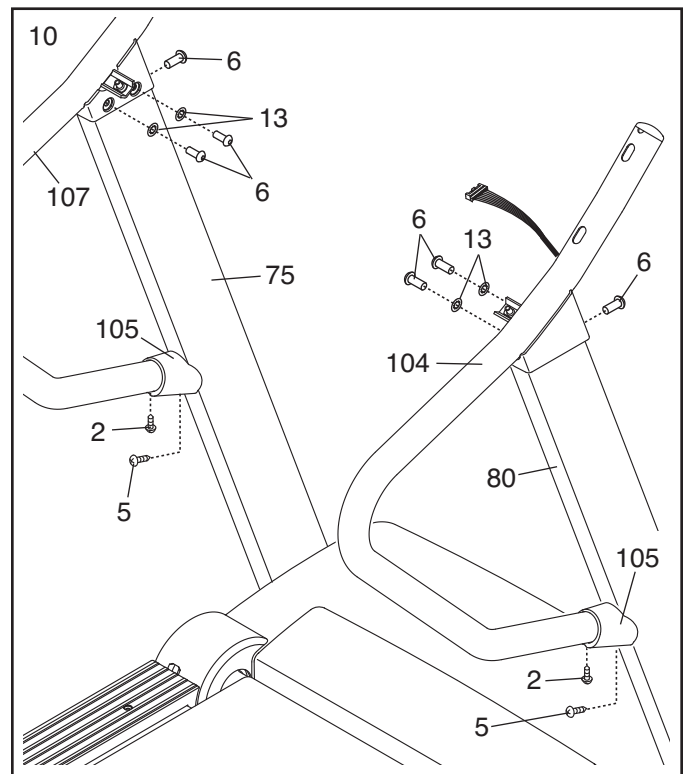

11. Set the console assembly face down on a soft surface to avoid scratching the console assembly.

Remove the two #8 x 1/2" Screws (2) from the Crossbar (106), and then remove the Crossbar. **Save the Crossbar and the two Screws for steps 12 and 15.**

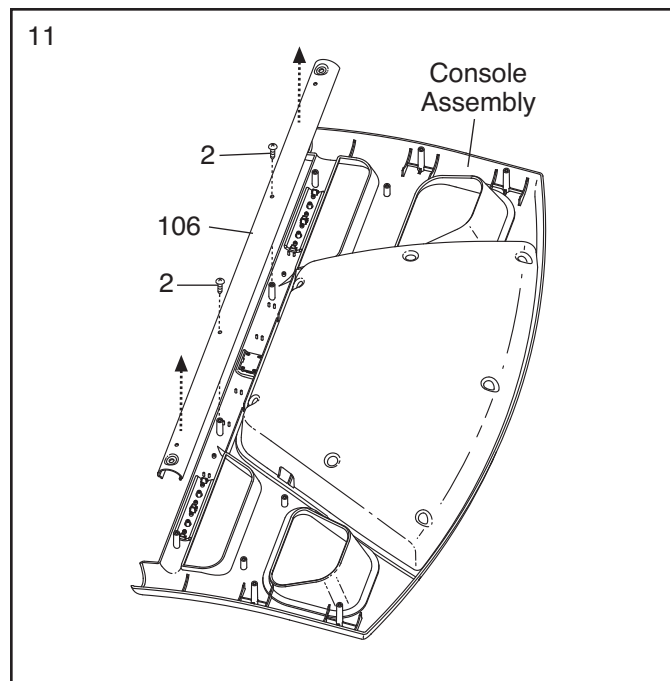

12. Attach the Crossbar (106) to the Right and Left Handrails (104, 107) with two 1/4" x 3/4" Bolts (10) and two 1/4" Star Washers (14). **Do not tighten the Bolts yet.**

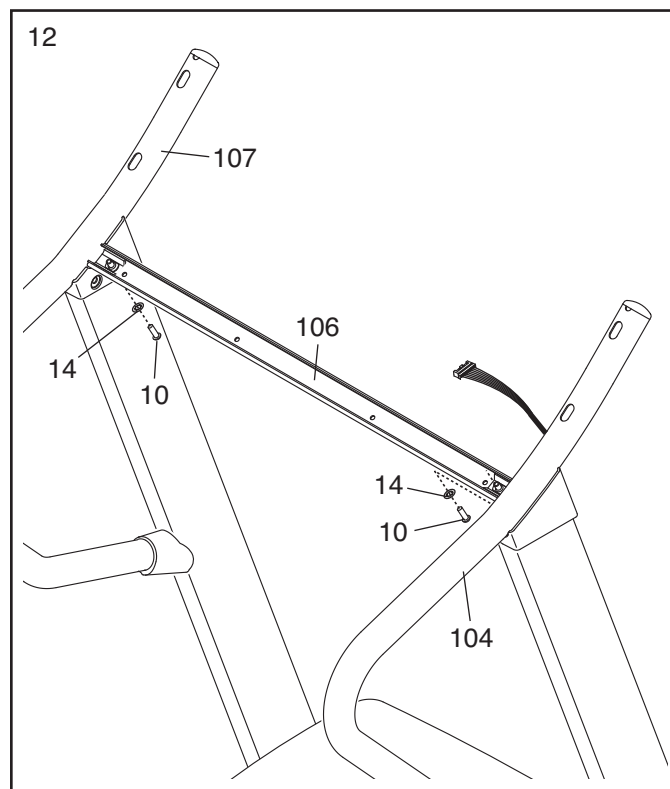

13. Have a second person hold the console assembly near the Right Handrail (104) and the Left Handrail (not shown). Connect the Upright Wire (79) to the console wire. **See the inset drawing. The connectors should slide together easily and snap into place.** If they do not, turn one connector and try again. **IF THE CONNECTORS ARE NOT CONNECTED PROPERLY, THE CONSOLE MAY BE DAMAGED WHEN YOU TURN ON THE POWER.**

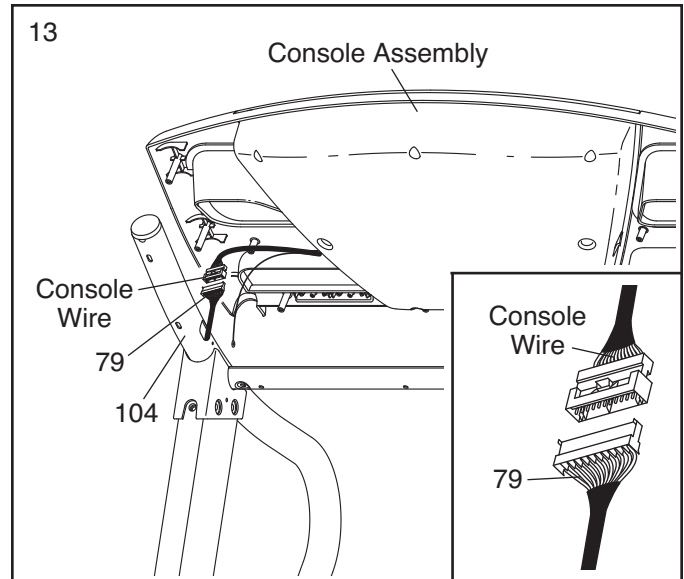

14. Attach the ground wire from the console assembly to the Right Handrail (104) with a #8 x 1/2" Ground Screw (3). **Note: It may be difficult to turn the Ground Screw.**

Set the console assembly on the Right Handrail (104) and the Left Handrail (not shown). **Be careful not to pinch the wires.** Insert the connectors and the excess wire into the Right Handrail.

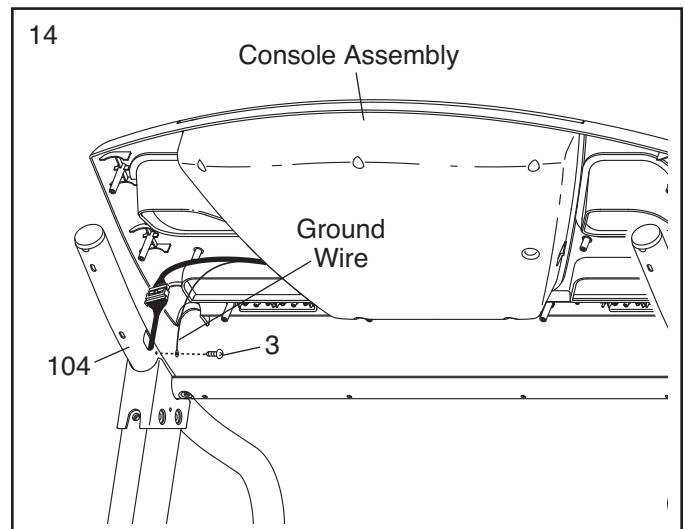

15. Attach the console assembly to the Right and Left Handrails (104, 107) and the Crossbar (106) with four #8 x 3/4" Screws (1) and four #8 x 1/2" Screws (2). **Start all eight Screws before tightening any of them.** Note: Use the two #8 x 1/2" Screws that you removed in step 10.

Tighten the six 5/16" x 1" Bolts (6) (only three are shown).

Tighten the two 1/4" x 3/4" Bolts (10) (only one is shown).

**See assembly steps 5 and 7.** Firmly tighten the four 3/8" x 4" Patch Bolts (9).

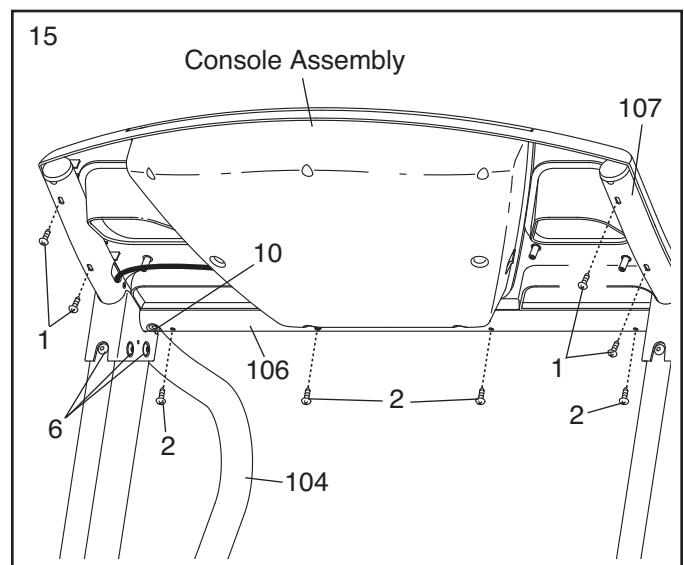

16. If necessary, press the Left Tray (94) and the Right Tray (103) into the Console Back (98).

Tighten a #8 x 1/2" Screw (2) into each Handrail Spacer (74, 78).

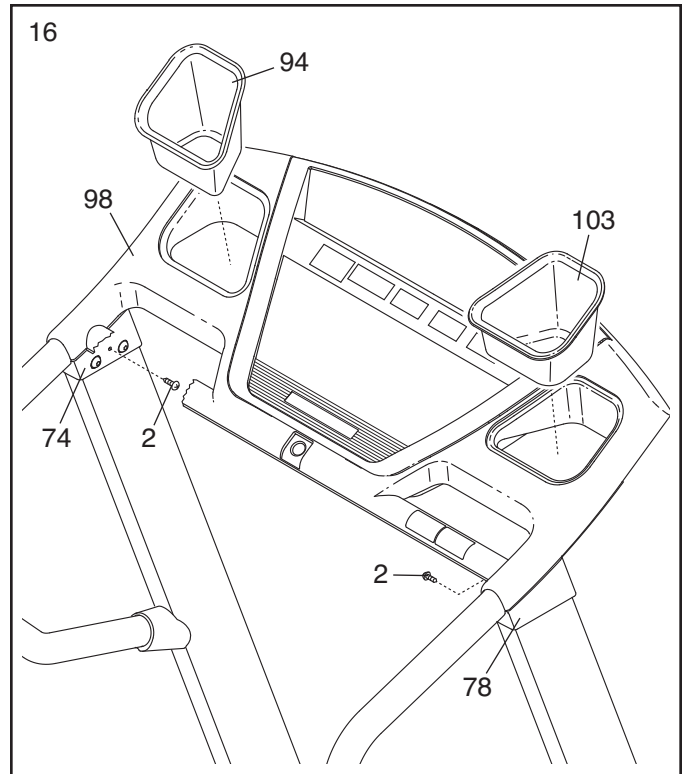

17. Raise the Frame (51) to the position shown. **Have a second person hold the Frame until this step is completed.**

Orient the Storage Latch (48) so that the large barrel and the latch knob are oriented as shown.

Attach the upper end of the Storage Latch (48) to the bracket on the Frame (51) with a 3/8" x 2" Bolt (7) and a 3/8" Nut (11).

Attach the lower end of the Storage Latch (48) to the Base (87) with a 3/8" x 1 3/4" Patch Bolt (8). Note: It may be necessary to move the Frame (51) back and forth to align the Storage Latch with the Base.

Lower the Frame (51) (see HOW TO LOWER THE TREADMILL FOR USE on page 21).

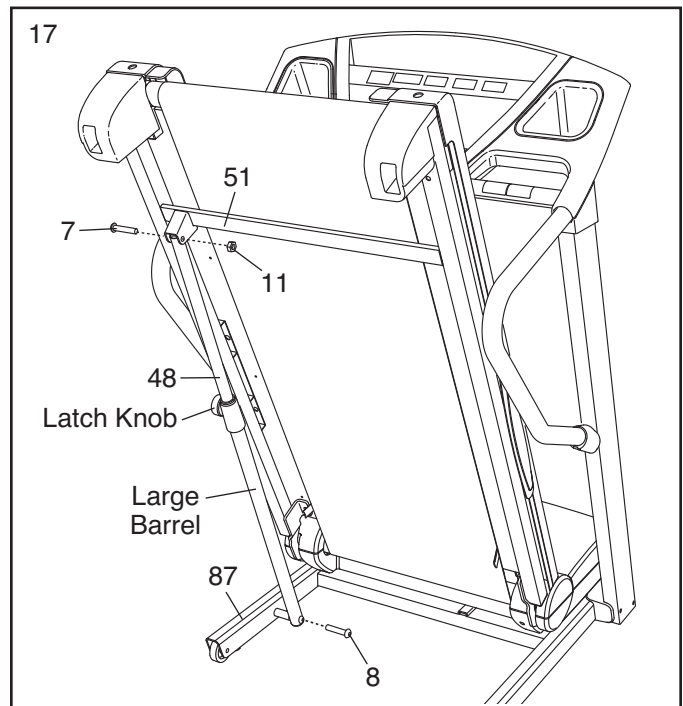

18. **Make sure that all parts are properly tightened before you use the treadmill.** If there are sheets of plastic on the treadmill decals, remove the plastic. To protect the floor or carpet, place a mat under the treadmill. Note: Extra hardware may be included. Keep the included hex keys in a secure place; one of the hex keys is used to adjust the walking belt (see pages 23 and 24).

# OPERATION AND ADJUSTMENT

## THE PRE-LUBRICATED WALKING BELT

Your treadmill features a walking belt coated with high-performance lubricant. **IMPORTANT: Never apply silicone spray or other substances to the walking belt or the walking platform. Such substances will deteriorate the walking belt and cause excessive wear.**

## HOW TO PLUG IN THE POWER CORD

**This product must be earthed.** If it should malfunction or break down, earthing provides a path of least resistance for electric current to reduce the risk of electric shock. This product is equipped with a power cord having an equipment-earthing conductor and an earthing plug. **IMPORTANT: If the power cord is damaged, it must be replaced with a manufacturer-recommended power cord.**

**⚠ DANGER:** Improper connection of the equipment-earthing conductor can result in an increased risk of electric shock. Check with a qualified electrician or serviceman if you are in doubt as to whether the product is properly earthed. Do not modify the plug provided with the product—if it will not fit the outlet, have a proper outlet installed by a qualified electrician.

Follow the steps below to plug in the power cord.

1. Plug the indicated end of the power cord into the socket on the treadmill.

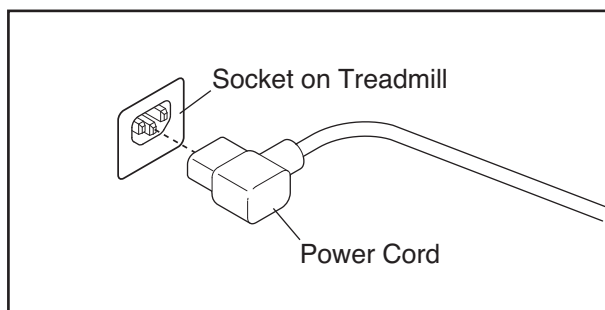

2. If you are plugging in the power cord in Australia, go to step 3.

If you are plugging in the power cord in the UK, first press the pins on the power cord into the metal clips in the adapter as shown. Close the adapter cover over the end of the power cord and tighten the screw in the adapter. **IMPORTANT: Make sure that the screw is tightened into the adapter cover.** Then, go to step 3.

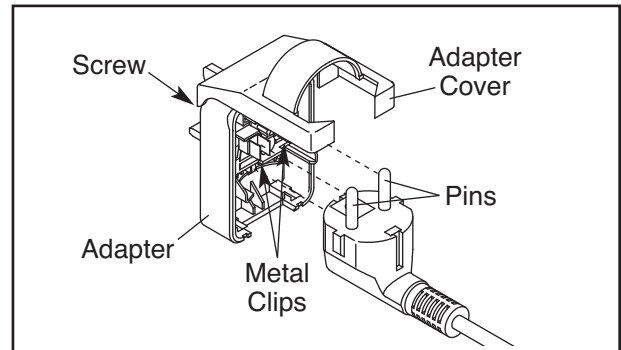

3. Plug the power cord into an appropriate outlet that is properly installed and earthed in accordance with all local codes and ordinances.

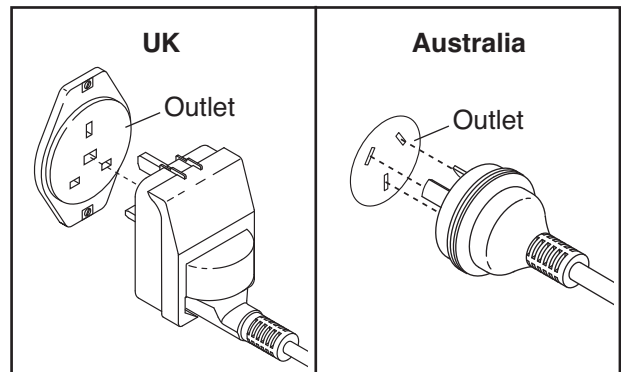

## CONSOLE DIAGRAM

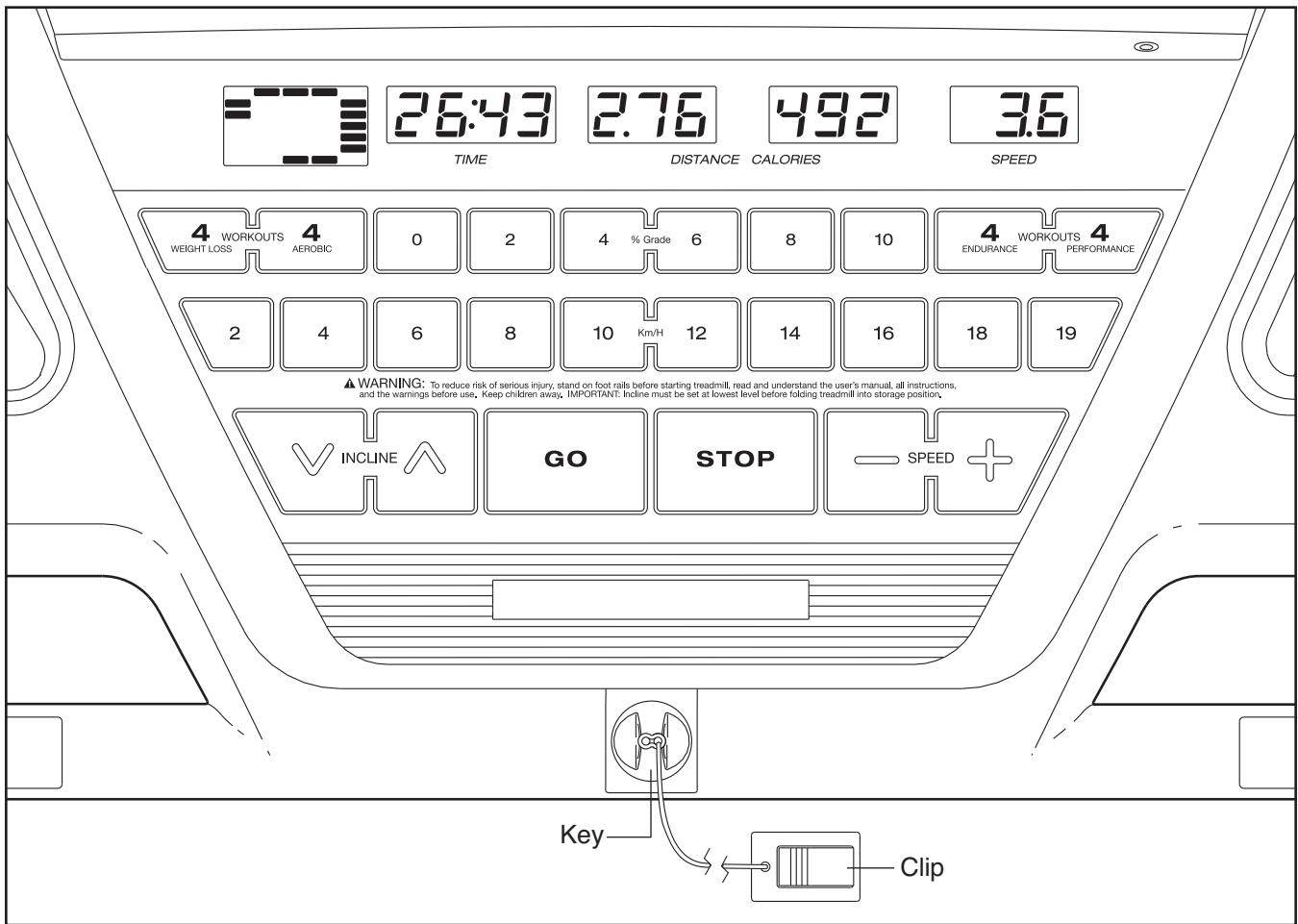

### FEATURES OF THE CONSOLE

The treadmill console offers an impressive array of features designed to make your workouts more effective and enjoyable.

When the manual mode of the console is selected, you can change the speed and incline of the treadmill with the touch of a button. As you exercise, the console will display instant exercise feedback. You can even measure your heart rate using the handgrip pulse sensor or the optional chest pulse sensor (see page 19).

In addition, the console offers sixteen preset workouts—four weight loss workouts, four aerobic workouts, four endurance workouts, and four performance workouts. Each workout automatically controls the speed and incline of the treadmill as it guides you through an effective exercise session.

You can even listen to your favorite workout music or audio books with the console's premium stereo sound system while you get in shape.

**To turn on the power**, see page 16. **To use the manual mode**, see page 16. **To use a preset workout**, see page 18. **To use the information mode**, see page 19. **To use the stereo sound system**, see page 19.

**IMPORTANT: If there is a sheet of plastic on the console, remove the plastic. To prevent damage to the walking platform, wear clean athletic shoes while using the treadmill. The first time the treadmill is used, observe the alignment of the walking belt, and center the walking belt if necessary (see page 24).**

Note: The console can display speed and distance in either kilometers or miles. To find out which unit of measurement is selected or to change the unit of measurement, see THE INFORMATION MODE on page 19. For simplicity, all instructions in this section refer to kilometers.

## HOW TO TURN ON THE POWER

**IMPORTANT:** If the treadmill has been exposed to cold temperatures, allow it to warm to room temperature before turning on the power. If you do not do this, you may damage the console displays or other electrical components.

Plug in the power cord (see page 14). Next, locate the reset/off circuit breaker on the treadmill frame near the power cord. Switch the circuit breaker to the reset position.

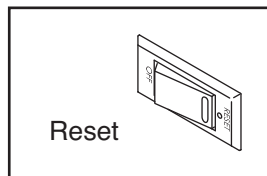

**IMPORTANT:** The console features a display demo mode, designed to be used if the treadmill is displayed in a store. If the displays light as soon as you plug in the power cord and switch the reset/off circuit breaker to the reset position, the demo mode is turned on. To turn off the demo mode, hold down the Stop button for a few seconds. If the displays remain lit, see THE INFORMATION MODE on page 19 to turn off the demo mode.

Next, stand on the foot rails of the treadmill. Find the clip attached to the key (see the drawing on page 15) and slide the clip onto the waistband of your clothes. Then, insert the key into the console. After a moment, the displays will light. **IMPORTANT:** In an emergency situation, the key can be pulled from the console, causing the walking belt to slow to a stop. Test the clip by carefully taking a few steps backward; if the key is not pulled from the console, adjust the position of the clip.

## HOW TO USE THE MANUAL MODE

### 1. Insert the key into the console.

See HOW TO TURN ON THE POWER at the left.

### 2. Select the manual mode.

When the key is inserted, the manual mode will be selected and a track will appear in the matrix. If a preset workout has been selected, remove the key and then reinsert it.

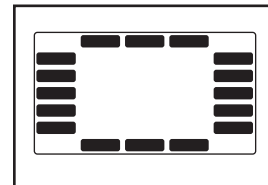

### 3. Start the walking belt.

To start the walking belt, press the Go button, the Speed increase button, or one of the speed buttons numbered 2 through 19.

If you press the Go button or the Speed increase button, the walking belt will begin to move at 2 Km/H. As you exercise, change the speed of the walking belt as desired by pressing the Speed increase and decrease buttons. Each time you press one of the buttons, the speed setting will change by 0.1 Km/H; if you hold down the button, the speed setting will change in increments of 0.5 Km/H. Note: After you press the buttons, it may take a moment for the walking belt to reach the selected speed setting.

If you press one of the numbered speed buttons, the walking belt will gradually change speed until it reaches the selected speed setting.

To stop the walking belt, press the Stop button. To restart the walking belt, press the Go button, the Speed increase button, or one of the speed buttons numbered 2 through 19.



**4. Change the incline of the treadmill as desired.**

To change the incline of the treadmill, press the Incline increase and decrease buttons or one of the numbered incline buttons. Each time you press the Incline increase or decrease button, the incline will change by 0.5 percent. If you press one of the numbered incline buttons, the treadmill will adjust to the selected incline setting. Note: After you press the buttons, it may take a moment for the treadmill to reach the selected incline setting.

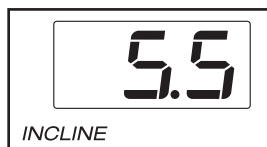

**5. Monitor your progress with the matrix and the displays.**

**The matrix**—When the manual mode is selected, the display will show a track that represents 1/4 mile (402 meters). As you exercise, the indicators around the track will light in succession until the entire track is lit. The track will then darken and the indicators will again begin to light in succession.

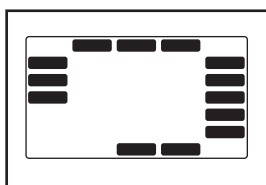

**Time display**—When the manual mode is selected, this display will show the elapsed time. When a workout is selected, the display will show the time remaining in the workout rather than the elapsed time.



**Distance/Incline display**—This display shows the distance that you have walked or run. This display will also show the incline setting for several seconds, each time the incline changes.



**Calories/Pulse display**—This display shows the approximate number of calories you have burned. The display will also show your heart rate when you use the handgrip pulse sensor.



**Speed display**—This display shows the speed of the walking belt.

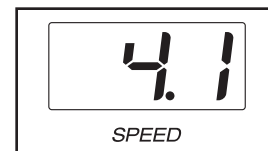

To reset the displays, press the Stop button, remove the key, and then reinsert the key.

**6. Measure your heart rate if desired.**

**Note: If you use the handgrip pulse sensor and the optional chest pulse sensor at the same time, the console will not display your heart rate accurately.** For information on the optional chest pulse sensor, see page 19.

Before using the handgrip pulse sensor, first remove the sheets of plastic from the metal contacts. In addition, make sure that your hands are clean.

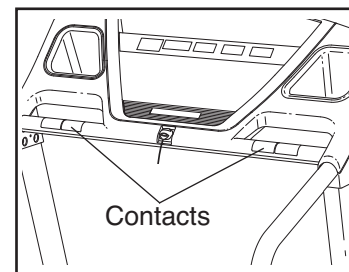

To use the handgrip pulse sensor, **stand on the foot rails** and hold the metal contacts for approximately 10 seconds. **Avoid moving your hands.** When your pulse is detected, your heart rate will be shown. **For the most accurate heart rate reading, continue to hold the contacts for about 15 seconds.**

**7. When you are finished exercising, remove the key from the console.**

Step onto the foot rails, press the Stop button, and **adjust the incline of the treadmill to the lowest setting. The incline must be at the lowest setting or you may damage the treadmill when you fold it to the storage position.** Next, remove the key from the console and put it in a secure place.

When you are finished using the treadmill, switch the reset/off circuit breaker to the off position and unplug the power cord. **IMPORTANT: If you do not do this, the treadmill's electrical components may wear prematurely.**

## HOW TO USE A PRESET WORKOUT

### 1. Insert the key into the console.

See HOW TO TURN ON THE POWER on page 16.

### 2. Select a preset workout.

To select a preset workout, press the Weight Loss, Aerobic, Endurance, or Performance button repeatedly.

When a preset workout is selected, the workout time will appear in the Time display, the minimum speed setting of the workout will appear in the Distance/Incline display, the maximum speed setting will appear in the Calories/Pulse display, and the name of the workout will appear in the Speed display. In addition, a profile of the speed settings of the workout will scroll across the matrix.



### 3. Start the walking belt.

Press the Go button to start the workout. A moment after you press the button, the treadmill will automatically adjust to the first speed and incline settings of the workout. Hold the handrails and begin walking.

Each workout is divided into one-minute segments. One speed setting and one incline setting are programmed for each segment. Note: The same speed setting and/or incline setting may be programmed for consecutive segments.

During the workout, the profile will show your progress. The flashing segment of the profile represents the current segment of the workout. The height of the flashing segment indicates the speed setting for the current segment. At the end of each segment, a series of tones will sound and the next

segment of the profile will begin to flash. If a different speed or incline setting is programmed for the next segment, the speed or incline setting will flash in the display to alert you. The treadmill will then automatically adjust to the new speed or incline setting.

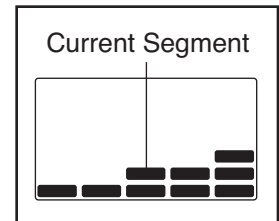

The workout will continue in this way until the last segment of the profile flashes in the display and the last segment ends. The walking belt will then slow to a stop.

If the speed or incline setting is too high or too low at any time during the workout, you can manually override the setting by pressing the Speed or Incline buttons; **however, when the next segment of the workout begins, the treadmill will automatically adjust to the speed and incline settings for the next segment.**

To stop the workout at any time, press the Stop button. To restart the workout, press the Go button. The walking belt will begin to move at 2 Km/H. When the next segment of the workout begins, the treadmill will automatically adjust to the speed and incline settings for the next segment.

### 4. Monitor your progress with the matrix and the displays.

See step 5 on page 17.

### 5. Measure your heart rate if desired.

See step 6 on page 17.

### 6. When you are finished exercising, remove the key from the console.

See step 7 on page 17.

## THE INFORMATION MODE

The console features an information mode that keeps track of the total number of hours that the treadmill has been used and the total distance that the walking belt has moved. The information mode also allows you to switch the measurement system from miles to kilometers and to turn on and turn off the display demo mode.

To select the information mode, hold down the Stop button while inserting the key into the console and then release the Stop button. When the information mode is selected, the following information will be shown:

The Time display will show the total number of hours the treadmill has been used.



The Distance/Incline display will show the total number of kilometers (or miles) that the walking belt has moved.



An “M” for metric kilometers or an “E” for English miles will appear in the Calories/Pulse display. Press the Speed increase button to change the unit of measurement if desired.

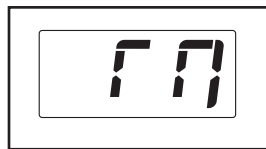

The console features a display demo mode, designed to be used if the treadmill is displayed in a store. While the demo mode is turned on, the console will function normally when you plug in the power cord, switch the reset/off circuit breaker to the reset position, and insert the key into the console. However, when you remove the key, the displays will remain lit, although the buttons will not function. If the demo mode is turned on, a “d” will appear in the Speed display while the information mode is selected. To turn on or turn off the demo mode, press the Speed decrease button.

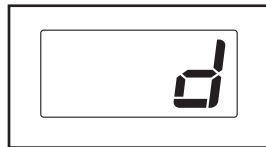

To exit the information mode, remove the key from the console.

## HOW TO USE THE STEREO SOUND SYSTEM

To play music or audio books through the console’s stereo speakers, you must connect your MP3 player, CD player, or other personal audio player to the console through the audio jack.

To use the audio jack, locate the audio wire and plug it into the audio jack near the speakers. Then, plug the audio wire into a jack on your MP3 player, CD player, or other personal audio player. **Make sure that the audio wire is fully plugged in.**

Next, press the Play button on your MP3 player, CD player, or other personal audio player.

If you are using a personal CD player and the CD skips, set the CD player on the floor or another flat surface instead of on the console.

## THE OPTIONAL CHEST PULSE SENSOR

An optional chest pulse sensor offers hands-free operation as it tracks your heart rate during your workouts. **To purchase the optional chest pulse sensor, call the telephone number on the front cover of this manual.**

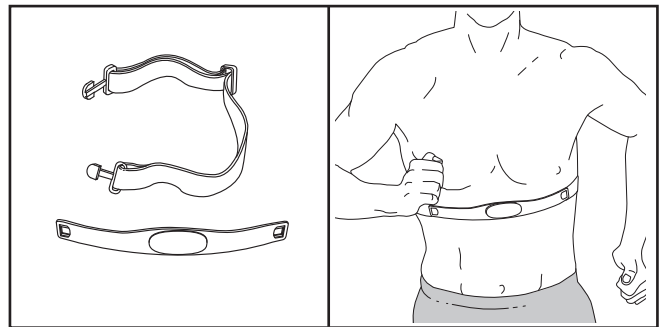

# HOW TO FOLD AND MOVE THE TREADMILL

## HOW TO FOLD THE TREADMILL FOR STORAGE

Before folding the treadmill, adjust the incline to the lowest position. If you do not do this, you may damage the treadmill when you fold it. Remove the key and unplug the power cord. **CAUTION:** You must be able to safely lift 45 lbs. (20 kg) to raise, lower, or move the treadmill.

1. Hold the metal frame firmly in the location shown by the arrow at the right. **CAUTION:** To decrease the possibility of injury, do not lift the frame by the plastic foot rails. Make sure to bend your legs and keep your back straight as you raise the frame. Raise the frame about halfway to the vertical position.
2. Raise the frame until the latch knob locks into the storage position. **Make sure that the latch knob is locked in the storage position.**

To protect the floor or carpet from damage, place a mat under the treadmill. Keep the treadmill out of direct sunlight. Do not leave the treadmill in the storage position in temperatures above 85° F (30° C).

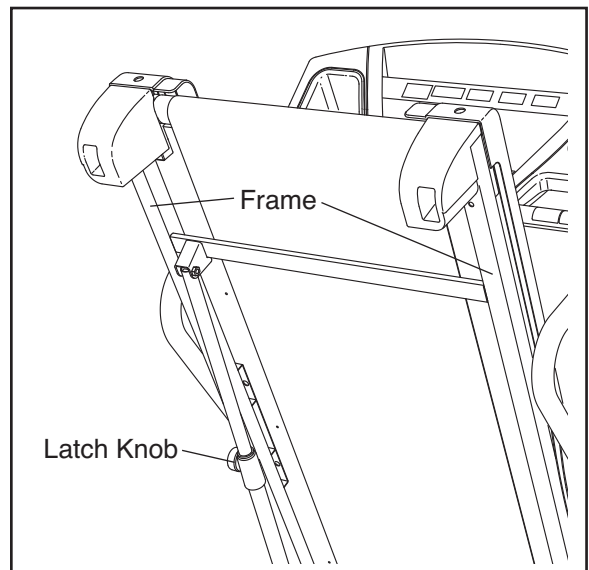
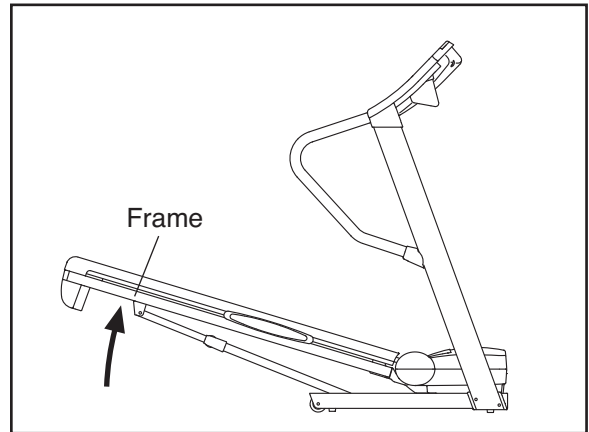

## HOW TO MOVE THE TREADMILL

Before moving the treadmill, convert the treadmill to the storage position as described above. **Make sure that the latch knob is locked in the storage position.**

1. Hold a handrail and the frame and place one foot against one of the wheels. Do not pull back on the frame.
2. Tip the treadmill back until it rolls freely on the wheels. Carefully move the treadmill to the desired location. **Never move the treadmill without tipping it back. To reduce the risk of injury, use extreme caution while moving the treadmill. Do not attempt to move the treadmill over an uneven surface.**
3. Place one foot against a wheel, and carefully lower the treadmill until it is resting in the storage position.

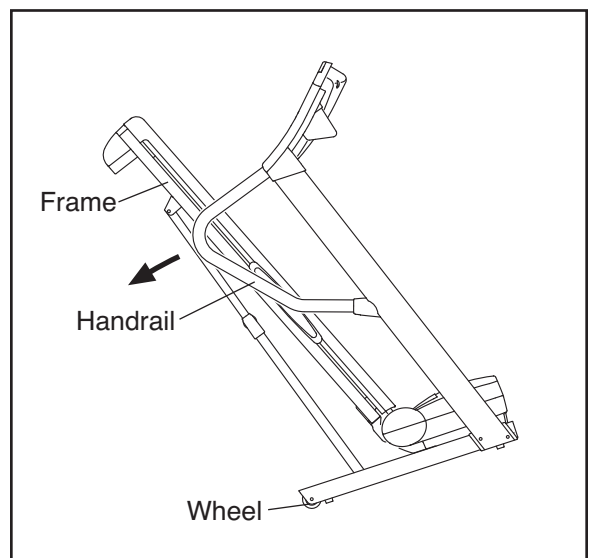

## HOW TO LOWER THE TREADMILL FOR USE

1. Hold the upper end of the treadmill with your right hand. Pull the latch knob to the left and hold it. It may be necessary to push the frame forward as you pull the knob to the left. Pivot the frame downward and release the latch knob.

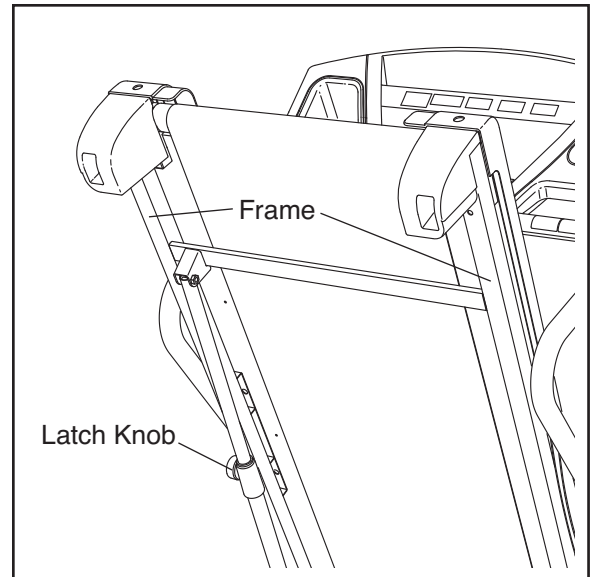

2. Hold the metal frame firmly with both hands and lower it to the floor. **CAUTION: Do not grip only the plastic foot rails or drop the frame to the floor. Bend your legs and keep your back straight.**

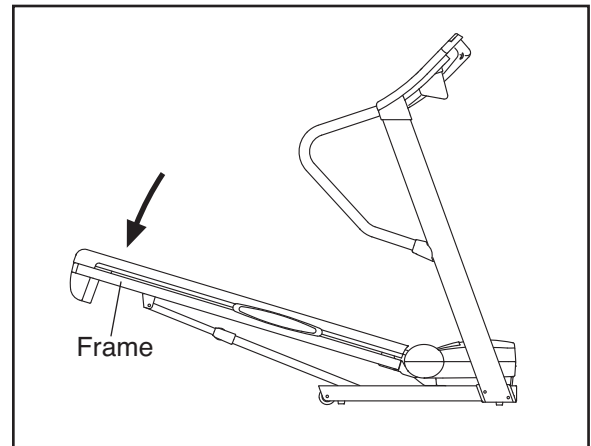

# TROUBLESHOOTING

Most treadmill problems can be solved by following the simple steps below. Find the symptom that applies, and follow the steps listed. If further assistance is needed, see the front cover of this manual.

## PROBLEM: The power does not turn on

**SOLUTION:** a. Make sure that the power cord is plugged into a properly earthed outlet. (See page 14.) If an extension cord is needed, use only a 3-conductor, 14-gauge (1 mm<sup>2</sup>) cord that is no longer than 5 ft. (1.5 m).

b. After the power cord has been plugged in, make sure that the key is inserted into the console.

c. Check the reset/off circuit breaker located on the treadmill frame near the power cord. If the switch protrudes as shown, the circuit breaker has tripped. To reset the circuit breaker, wait for five minutes and then press the switch back in.

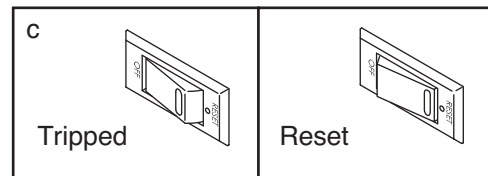

## PROBLEM: The power turns off during use

**SOLUTION:** a. Check the reset/off circuit breaker (see the drawing above). If the circuit breaker has tripped, wait for five minutes and then press the switch back in.

b. Make sure that the power cord is plugged in. If the power cord is plugged in, unplug it, wait for five minutes, and then plug it back in.

c. Remove the key from the console. Reinsert the key into the console.

d. If the treadmill still will not run, please see the front cover of this manual.

## PROBLEM: The console displays remain lit when you remove the key from the console

**SOLUTION:** a. The console features a display demo mode, designed to be used if the treadmill is displayed in a store. If the displays remain lit when you remove the key, the demo mode is turned on. To turn off the demo mode, hold down the Stop button for a few seconds. If the displays are still lit, see THE INFORMATION MODE on page 19 to turn off the demo mode.

## PROBLEM: The displays of the console do not function properly

**SOLUTION:** a. Remove the key from the console and **UNPLUG THE POWER CORD**. With the help of a second person, carefully tip down the Uprights (75, 80). There may be three #8 x 2" Screws (16) in the bottom of the Belly Pan (73). If there are, remove them. Note: A Phillips screwdriver with a shaft at least 5 in. (13 cm) long is required.

Then, raise the Uprights (75, 80).

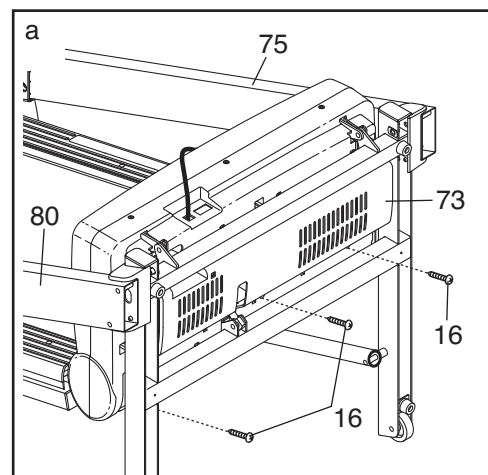

Remove the three #8 x 3/4" Screws (1) and carefully pivot the Motor Hood (60) off.

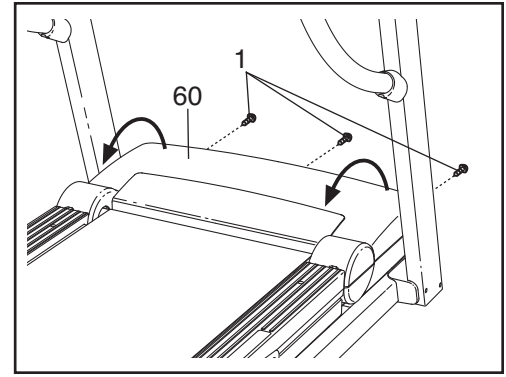

Locate the Reed Switch (71) and the Magnet (45) on the left side of the Pulley (46). Turn the Pulley until the Magnet is aligned with the Reed Switch. **Make sure that the gap between the Magnet and the Reed Switch is about 1/8 in. (3 mm).** If necessary, loosen the 3/4" Screw (17), move the Reed Switch slightly, and then retighten the Screw. Reattach the Motor Hood (not shown). Reattach the #8 x 2" Screws (not shown) if necessary. Run the treadmill for a few minutes to check for a correct speed reading.

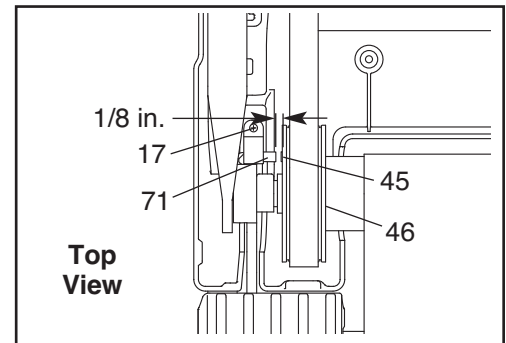

**PROBLEM: The incline of the treadmill does not change correctly**

**SOLUTION:** a. With the key in the console, press one of the Incline buttons. **While the incline is changing, remove the key.** After a few seconds, re-insert the key. The treadmill will automatically rise to the maximum incline level and then return to the minimum level. This will recalibrate the incline system.

**PROBLEM: The walking belt slows when walked on**

**SOLUTION:** a. If an extension cord is needed, use only a 3-conductor, 14-gauge (1 mm<sup>2</sup>) cord that is no longer than 5 ft. (1.5 m).

b. If the walking belt is overtightened, treadmill performance may decrease and the walking belt may become damaged. Remove the key and **UNPLUG THE POWER CORD.** Using the hex key, turn both idler roller bolts counterclockwise, 1/4 of a turn. When the walking belt is properly tightened, you should be able to lift each edge of the walking belt 2 to 3 in. (5 to 7 cm) off the walking platform. Be careful to keep the walking belt centered. Then, plug in the power cord, insert the key, and run the treadmill for a few minutes. Repeat until the walking belt is properly tightened.

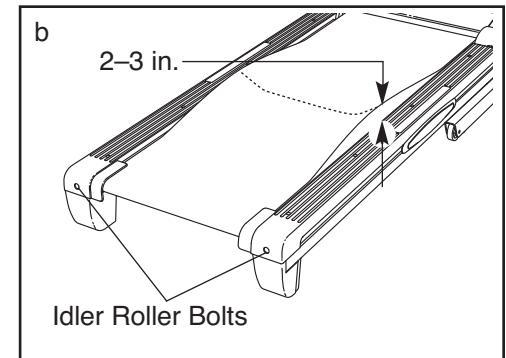

c. If the walking belt still slows when walked on, see the front cover of this manual.

**PROBLEM: The walking belt is off-center or slips when walked on**

**SOLUTION:** a. **If the walking belt is off-center**, first remove the key and **UNPLUG THE POWER CORD**. **If the walking belt has shifted to the left**, use the hex key to turn the left idler roller bolt clockwise 1/2 of a turn; **if the walking belt has shifted to the right**, turn the bolt counterclockwise 1/2 of a turn. Be careful not to overtighten the walking belt. Then, plug in the power cord, insert the key, and run the treadmill for a few minutes. Repeat until the walking belt is centered.

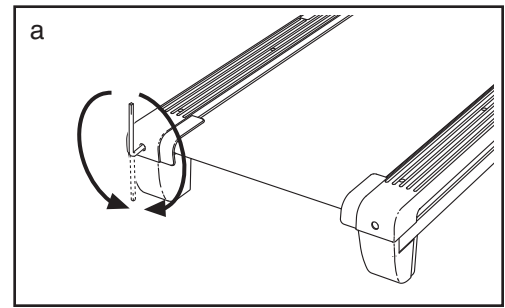

b. **If the walking belt slips when walked on**, first remove the key and **UNPLUG THE POWER CORD**. Using the hex key, turn both idler roller bolts clockwise, 1/4 of a turn. When the walking belt is correctly tightened, you should be able to lift each edge of the walking belt 2 to 3 in. (5 to 7 cm) off the walking platform. Be careful to keep the walking belt centered. Then, plug in the power cord, insert the key, and carefully walk on the treadmill for a few minutes. Repeat until the walking belt is properly tightened.

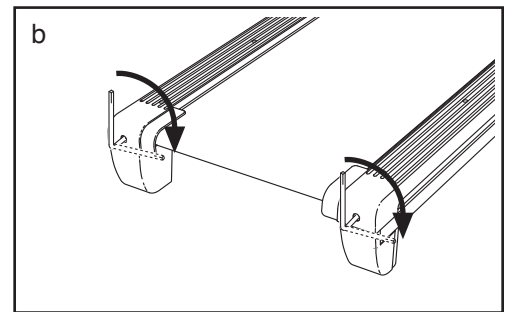



# EXERCISE GUIDELINES

**⚠️ WARNING:** Before beginning this or any exercise program, consult your physician. This is especially important for persons over age 35 or persons with pre-existing health problems.

The pulse sensor is not a medical device. Various factors may affect the accuracy of heart rate readings. The pulse sensor is intended only as an exercise aid in determining heart rate trends in general.

These guidelines will help you to plan your exercise program. For detailed exercise information, obtain a reputable book or consult your physician. Remember, proper nutrition and adequate rest are essential for successful results.

## EXERCISE INTENSITY

Whether your goal is to burn fat or to strengthen your cardiovascular system, exercising at the proper intensity is the key to achieving results. You can use your heart rate as a guide to find the proper intensity level. The chart below shows recommended heart rates for fat burning and aerobic exercise.

165	155	145	140	130	125	115	♥
145	138	130	125	118	110	103	♥
125	120	115	110	105	95	90	♥
<hr/>							
20	30	40	50	60	70	80	

To find the proper intensity level, find your age at the bottom of the chart (ages are rounded off to the nearest ten years). The three numbers listed above your age define your “training zone.” The lowest number is the heart rate for fat burning, the middle number is the heart rate for maximum fat burning, and the highest number is the heart rate for aerobic exercise.

**Burning Fat**—To burn fat effectively, you must exercise at a low intensity level for a sustained period of time. During the first few minutes of exercise, your body uses *carbohydrate calories* for energy. Only after the first few minutes of exercise does your body begin to use stored *fat calories* for energy. If your goal is to burn fat, adjust the intensity of your exercise until your heart rate is near the lowest number in your training zone. For maximum fat burning, exercise with your heart rate near the middle number in your training zone.

**Aerobic Exercise**—If your goal is to strengthen your cardiovascular system, you must perform aerobic exercise, which is activity that requires large amounts of oxygen for prolonged periods of time. For aerobic exercise, adjust the intensity of your exercise until your heart rate is near the highest number in your training zone.

## WORKOUT GUIDELINES

**Warming Up**—Start with 5 to 10 minutes of stretching and light exercise. A warm-up increases your body temperature, heart rate, and circulation in preparation for exercise.

**Training Zone Exercise**—Exercise for 20 to 30 minutes with your heart rate in your training zone. (During the first few weeks of your exercise program, do not keep your heart rate in your training zone for longer than 20 minutes.) Breathe regularly and deeply as you exercise—never hold your breath.

**Cooling Down**—Finish with 5 to 10 minutes of stretching. Stretching increases the flexibility of your muscles and helps to prevent post-exercise problems.

## EXERCISE FREQUENCY

To maintain or improve your condition, complete three workouts each week, with at least one day of rest between workouts. After a few months of regular exercise, you may complete up to five workouts each week, if desired. Remember, the key to success is to make exercise a regular and enjoyable part of your everyday life.

# PART LIST—Model No. PETL84909.0

R0310A

To locate the parts listed below, see the EXPLODED DRAWING near the end of this manual.

Key No.	Qty.	Description	Key No.	Qty.	Description
1	17	#8 x 3/4" Screw	51	1	Frame
2	9	#8 x 1/2" Screw	52	1	Left Rear Foot
3	1	#8 x 1/2" Ground Screw	53	1	Idler Roller Ground Wire
4	4	#8 x 1" Tek Screw	54	1	Right Rear Foot
5	2	#10 x 3/4" Screw	55	1	Idler Roller
6	6	5/16" x 1" Bolt	56	2	Idler Roller Bracket
7	3	3/8" x 2" Bolt	57	1	5/32" Hex Key
8	1	3/8" x 1 3/4" Patch Bolt	58	1	Hex Key
9	4	3/8" x 4" Patch Bolt	59	1	Hood Accent
10	2	1/4" x 3/4" Bolt	60	1	Motor Hood
11	3	3/8" Nut	61	1	Lift Frame
12	4	3/8" Star Washer	62	1	Lift Frame Ground Wire
13	4	5/16" Star Washer	63	3	Wire Tie
14	2	1/4" Star Washer	64	1	Drive Belt
15	5	#8 x 3/4" Tek Screw	65	1	Drive Motor
16	3	#8 x 2" Screw	66	1	Controller Ground Wire
17	9	3/4" Screw	67	1	Power Cord
18	2	5/16" x 1 1/2" Bolt	68	1	Power Cord Adapter
19	2	5/16" x 3 5/8" Bolt	69	1	Reset/Off Circuit Breaker
20	2	3/8" x 1" Bolt	70	1	Controller
21	2	Idler Roller Bolt	71	1	Reed Switch
22	1	3/8" x 1 3/4" Incline Bolt	72	1	Reed Switch Clamp
23	1	3/8" x 1 1/2" Bolt	73	1	Belly Pan
24	2	3/8" x 3/4" Bolt	74	1	Left Handrail Spacer
25	15	#8 x 1/2" Bright Screw	75	1	Left Upright
26	8	#12 x 1 1/4" Screw	76	1	Incline Motor
27	2	Motor Bolt	77	1	Incline Motor Spacer
28	4	Belt Guide Screw	78	1	Right Handrail Spacer
29	2	1/4" Washer	79	1	Upright Wire
30	2	1/4" Split Washer	80	1	Right Upright
31	4	3/8" Jam Nut	81	4	Bolt Spacer
32	4	5/16" Flange Nut	82	1	Right Upright Spacer
33	3	Hood Clip	83	2	Base Cap
34	6	#3 x 1/4" Screw	84	4	Base Foot
35	2	Foot Rail Decal	85	2	Caution Decal
36	1	Left Foot Rail	86	1	Left Upright Spacer
37	1	Warning Decal	87	1	Base
38	2	Platform Cushion	88	2	Wheel
39	1	Walking Platform	89	2	Base Foot Spacer
40	1	Walking Belt	90	2	15 1/2" Wire Tie
41	2	Belt Guide	91	6	Releasable Tie
42	2	Frame Cap	92	6	8" Tie
43	2	Frame Spacer	93	1	Key/Clip
44	1	1/4" x 1" Bolt	94	1	Left Tray
45	1	Magnet	95	1	Audio Wire
46	1	Drive Roller/Pulley	96	1	Console
47	1	Transformer	97	3	Wire Tie
48	1	Storage Latch	98	1	Console Back
49	1	Filter	99	4	Pulse Plate
50	1	Right Foot Rail	100	2	Upper Handrail Cap

Key No.	Qty.	Description	Key No.	Qty.	Description
101	1	Key Plate	109	1	Incline Motor Wire
102	6	Console Clamp	110	1	Electronics Bracket
103	1	Right Tray	111	2	Motor Bushing
104	1	Right Handrail	112	1	Motor Plate
105	2	Handrail Cap	113	1	Receptacle
106	1	Crossbar	114	1	Access Door
107	1	Left Handrail	*	–	User's Manual
108	2	#8 x 1 1/2" Screw			

Note: Specifications are subject to change without notice. For information about ordering replacement parts, see the back cover of this manual. \*These parts are not illustrated.

# EXPLODED DRAWING A—Model No. PETL84909.0

R0310A

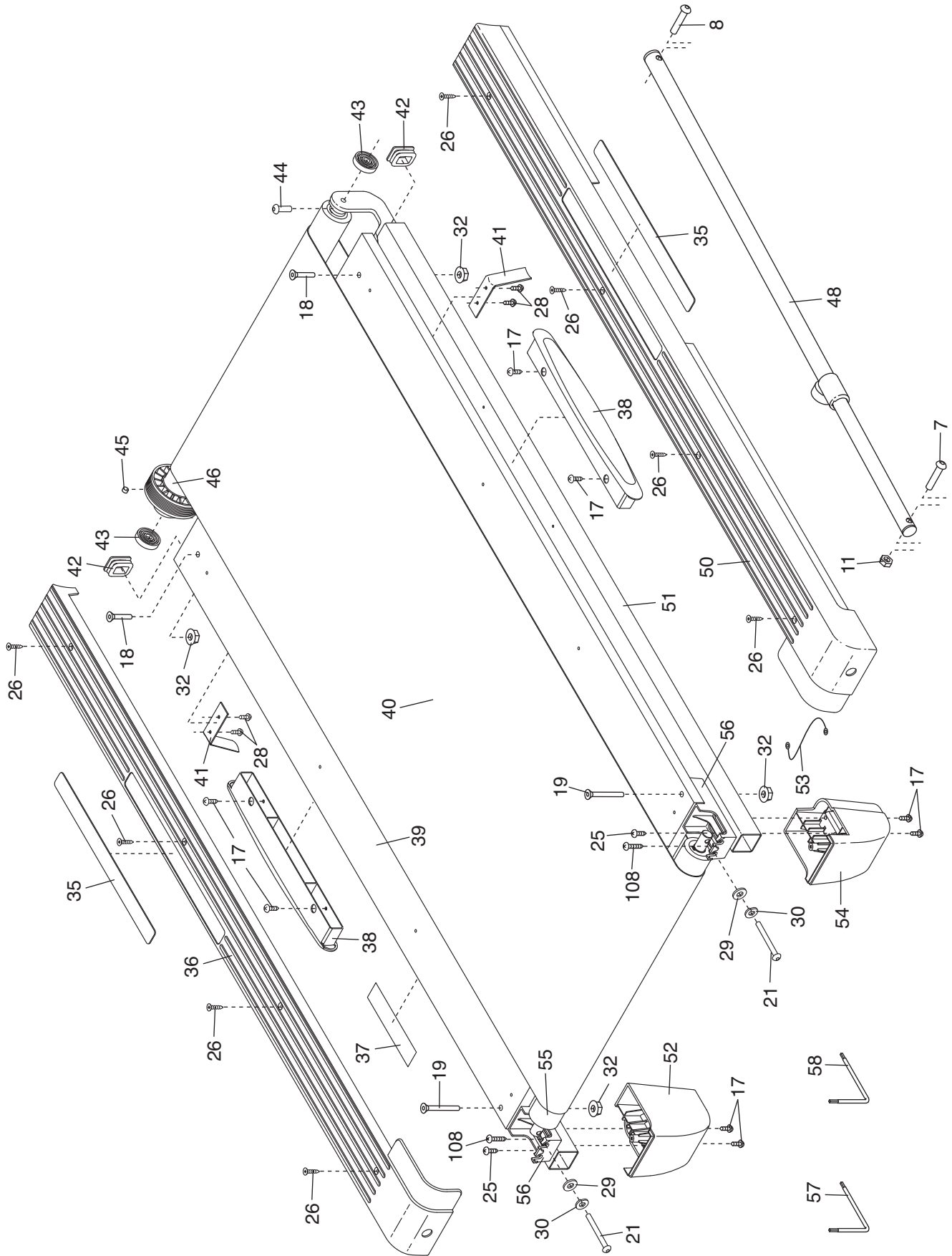

# EXPLODED DRAWING B—Model No. PETL84909.0

R0310A

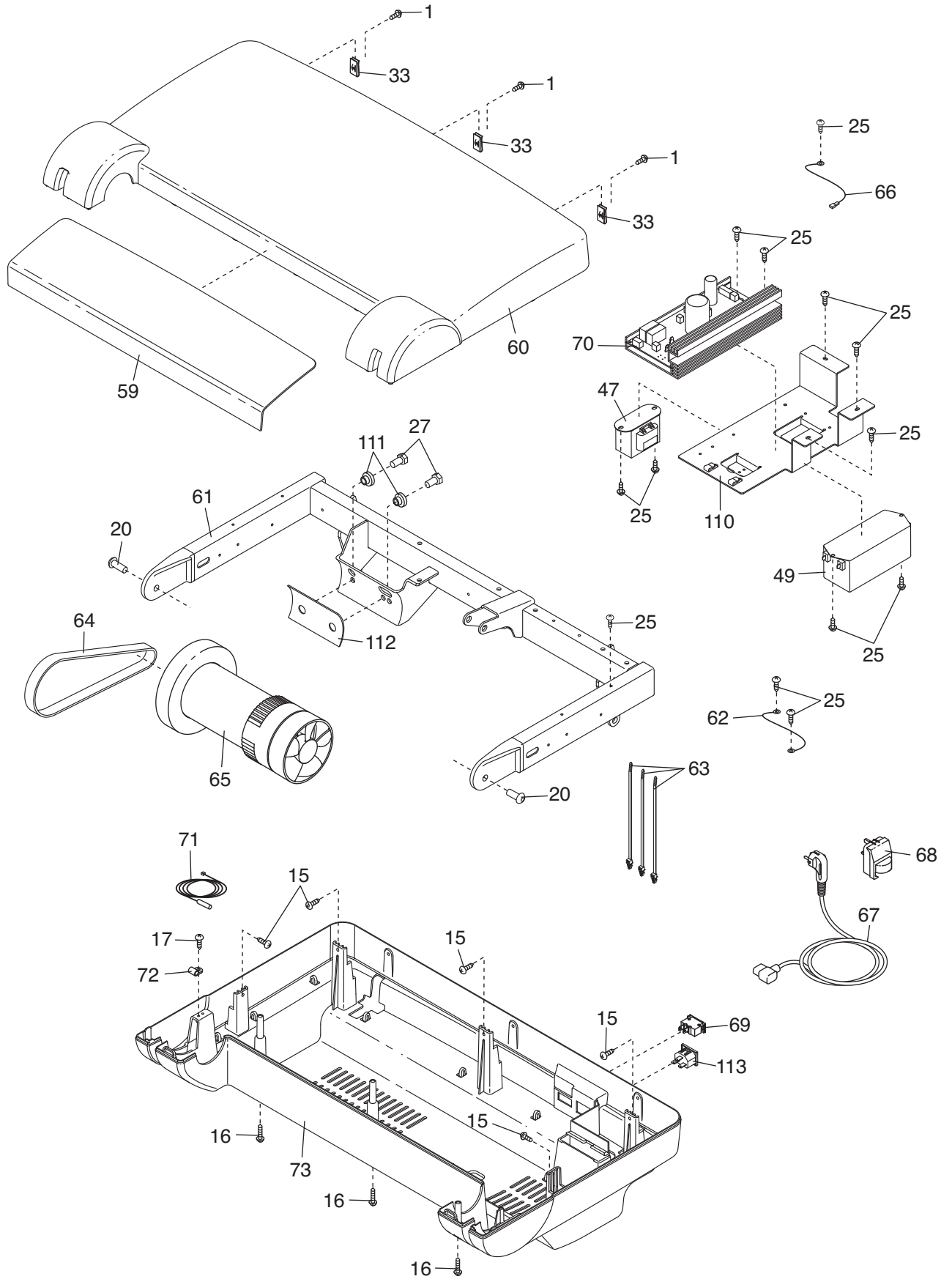

# EXPLODED DRAWING C—Model No. PETL84909.0

R0310A

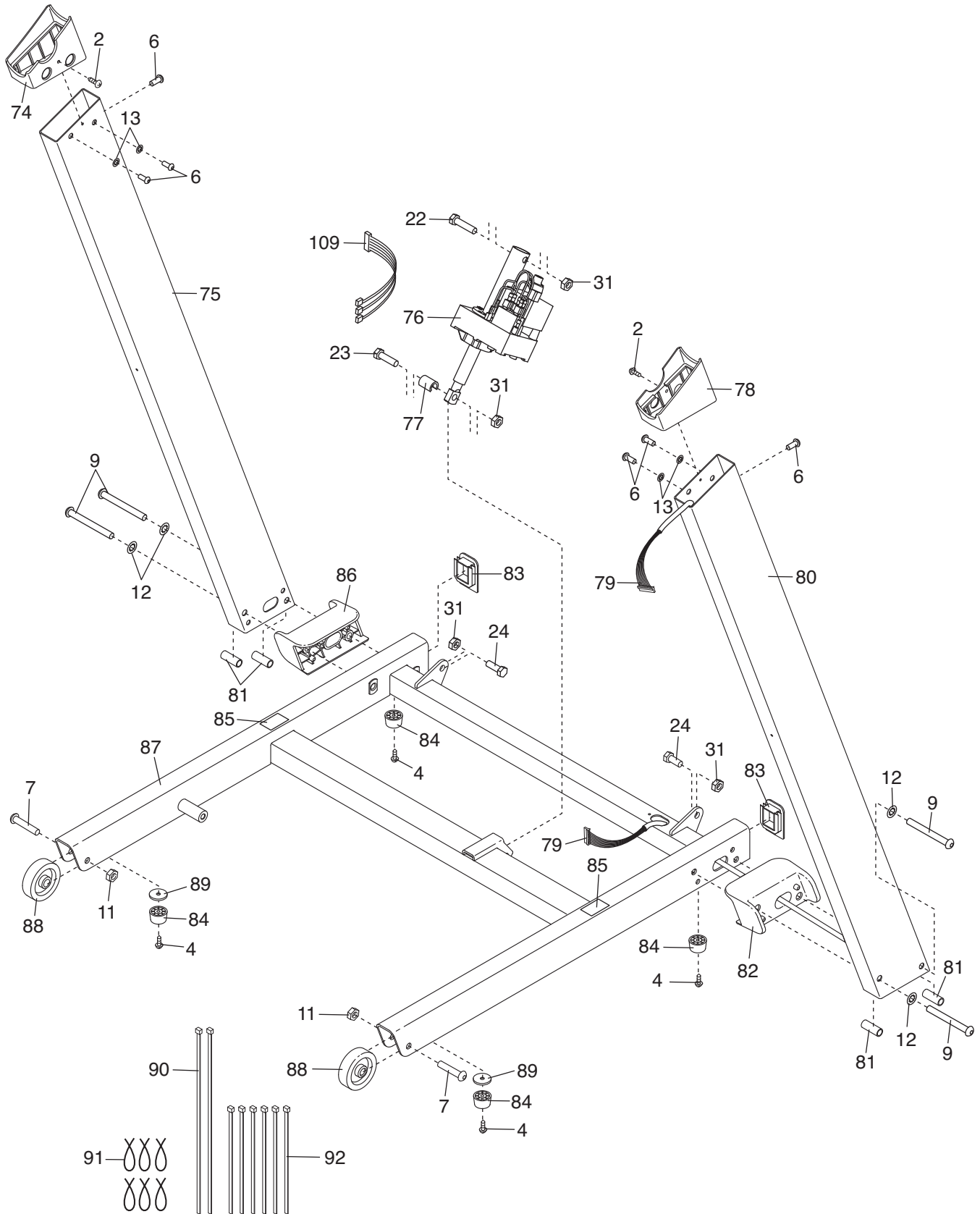

# EXPLODED DRAWING D—Model No. PETL84909.0

R0310A

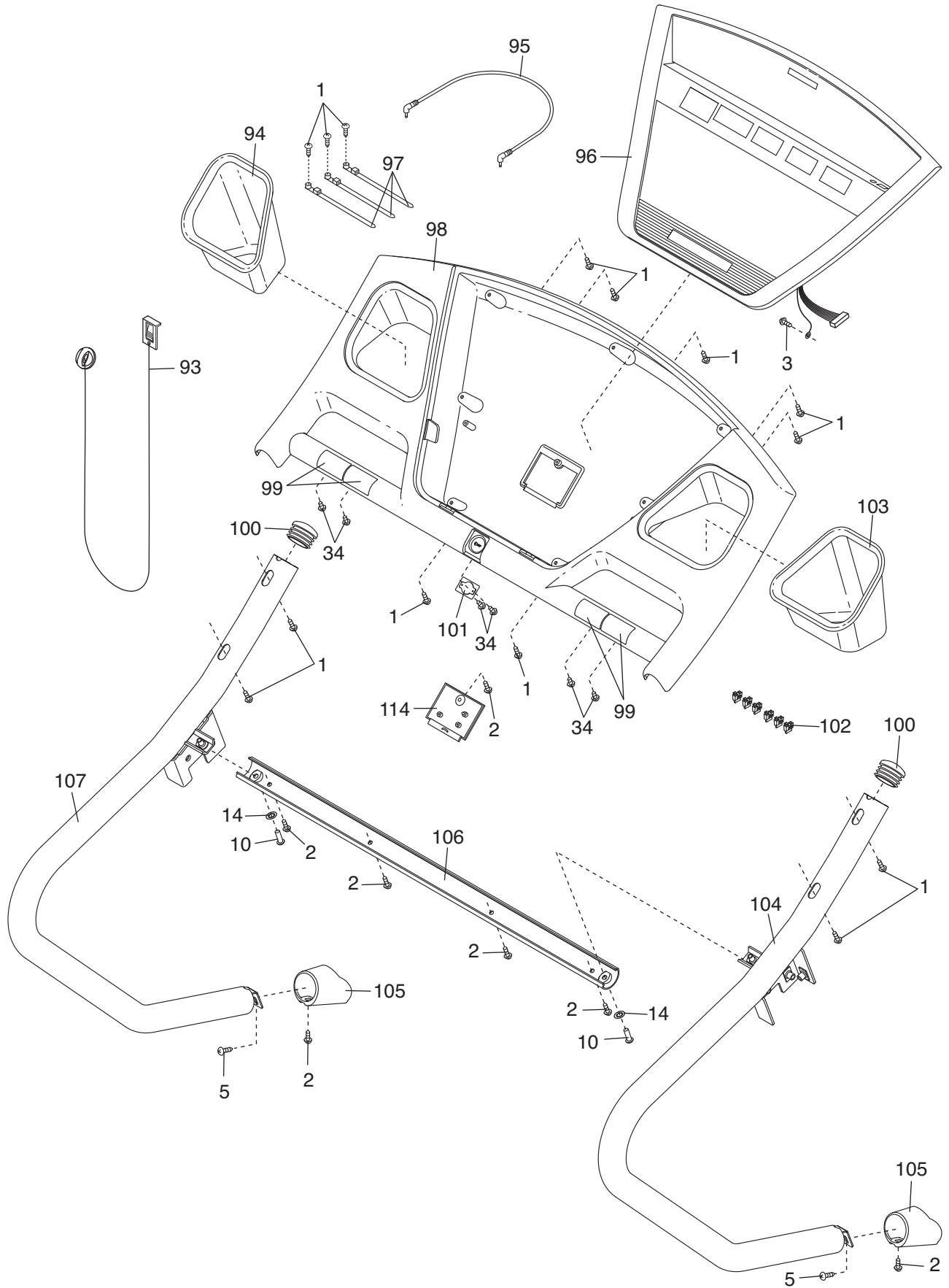

---

## ORDERING REPLACEMENT PARTS

To order replacement parts, please see the front cover of this manual. To help us assist you, be prepared to provide the following information when contacting us:

- the model number and serial number of the product (see the front cover of this manual)
- the name of the product (see the front cover of this manual)
- the key number and description of the replacement part(s) (see the PART LIST and the EXPLODED DRAWING near the end of this manual)

---

## RECYCLING INFORMATION

**This electronic product must not be disposed of in municipal waste. To preserve the environment, this product must be recycled after its useful life as required by law.**

Please use recycling facilities that are authorized to collect this type of waste in your area. In doing so, you will help to conserve natural resources and improve European standards of environmental protection. If you require more information about safe and correct disposal methods, please contact your local city office or the establishment where you purchased this product.

