

EN

USERMANUAL

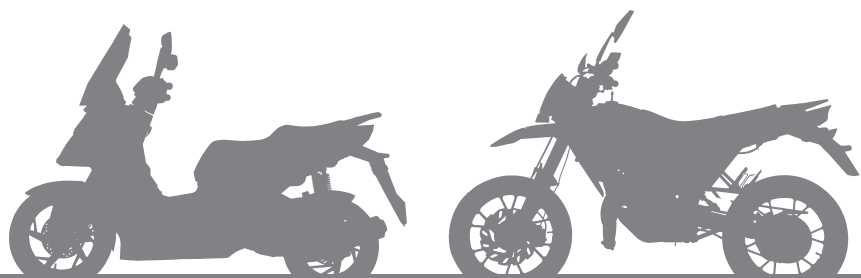

mod.# J68

IMPORTANT MANUAL INFORMATION

Congratulations on your purchase of the motorcycle. This model is the result of a vast experience in the production of fine sporting, touring and racing machines. It represents the high degree of craftsmanship and reliability that have made us to one of the leaders in these fields.

This manual will give you an understanding of the operation, inspection, and basic maintenance of this motorcycle. If you have any questions concerning the operation or maintenance of your motorcycle, please consult a dealer.

The design and manufacture of this motorcycle fully comply with the emissions standards for clean air applicable at the date of manufacture. We have met these standards without reducing the performance or economy of operation of the motorcycle. To maintain these high standards, it is important that you and your dealer pay close attention to the recommended maintenance schedules and operating instructions contained within this manual.

IMPORTANT MANUAL INFORMATIONS

Particularly important information is distinguished in this manual by the following notations:

⚠ WARNING Failure to follow **WARNING** instructions could result in severe injury or death of the motorcycle operator a bystander or a person inspecting or repairing the motorcycle.

CAUTION A **CAUTION** indicates special precautions that must be taken to avoid damage to the motorcycle.
NOTE: A NOTE provides key information to make procedures easier or clearer.

NOTE:

- Please always put the manual with the vehicle for maintenance and service records.
- This manual contains important vehicle information. However the producer will continually improve this product and the design and the quality that lead to difference between the manual and the current version of the vehicle.

If you have any questions concerning this manual please consult your dealer.

⚠ WARNING

FOR YOUR OWN SAFETY PLEASE READ THIS MANUAL CAREFULLY BEFORE YOU DRIVE THIS MOTORCYCLE. ONLY OPERATE THE MOTORCYCLE WHEN YOU HAVE BEEN COMPLETELY AWARE OF ADEQUATE KNOWLEDGE OF CONTROLS AND OPERATION AND FEATURES AND YOU HAVE BEEN TRAINED IN SAFETY AND PROPER RIDING TECHNIQUES. PERIODIC INSPECTIONS AND MAINTENANCE AND GOOD DRIVING SKILLS WILL ENSURE YOUR SAFETY DRIVING AND INCREASE THE PRODUCT RELIABILITY OF THIS MOTORCYCLE.

**Product and specifications are subject to change without notice.*

IMPORTANT MANUAL INFORMATION

DEALER
STAMP HERE

TABLE OF CONTENTS

SAFETY INFORMATION	6	PRE-OPERATIONCHECKS	22	ECU	32
Other Safe driving points.....	9	Pre-operation check list	23	Adjust the idling.....	32
Location of labels	10			Checking the throttle cable free play.....	32
DESCRIPTION	11	OPERATION AND IMPORTANT RIDING POINTS	24	Clutch adjustment.....	33
Left view	11	Starting the engine	24	Tires.....	33
Right view.....	12	Stop the engine	24	Tire inspection.....	33
Operation instruments	13	Shifting and riding.....	24	Cast wheels.....	34
		Acceleration and deceleration.....	25	Front brake	34
INSTRUMENT AND CONTROL FUNCTIONS	14	Engine break-in	25	Front brake adjustment	35
Main switch/steering lock.....	14	Inspection Information.....	26	Rear brake adjustment.....	35
Indicator and warning lights	15	Parking	26	Brake pads.....	36
Handlebar switches	17			Front and rear brake brake fluid..	36
Front brake lever	18	CHECKING/ MAINTAINING SERVICE INTERVALS	27	Lubricating of the cables.....	37
Rear brake pedal	18	Periodic maintenance chart.....	28	Front forke.....	37
Fuel/ Fuel Tank	18	Spark plug.....	30	Steering.....	37
Seat.....	19	Airfilter.....	30	Wheel bearings.....	38
Engine oil.....	20	Oil drain pipe.....	30	Adjusting the chain tension	38
Sidesstand.....	21	Coolant inspection.....	31	Shock absorber.....	38
Catalytic converter.....	21	Bleeding the coolant system.....	31	Battery.....	39
				Fuses.....	40

TABLE OF CONTENTS

Replacing headlight bulb.....	41
Front and rear turnsignal lamp....	41
Tail/brake and license plate lamp...	
.....	41
Injection system.....	41
Fuel pump.....	41
Fuel filter.....	42
TROUBLESHOOTING.....	42
Troubleshooting chart.....	43
CLEAN AND STORAGE.....	45
Clean.....	45
Storage.....	46
SPECIFICATIONS.....	47
WIRING DIAGRAM.....	48
WARRANTY INFORMATION.....	49
SERVICE PLAN	50

SAFETY INFORMATION

THIS MOTORCYCLE IS A TWO WHEEL ON ROAD VEHICLE.

BEFORE YOU USE THE VEHICLE THE FIRST TIME PLEASE READ THIS MANUAL CAREFULLY IN ORDER TO FAMILIARIZE YOURSELF WITH YOUR NEW MOTORCYCLE.

THE USER OF THIS MOTORCYCLE SHOULD BE/ SHOULD HAVE:

- **WELL TRAINED AND FAMILIAR TO ALL THE ASPECTS OF MOTORCYCLE OPERATION ESPECIALLY THE OPERATION OF THIS MODEL.**

- **FULLY INSTRUCTED IN THE MAINTENANCE REQUIREMENTS THAT NOTED IN THIS MANUAL.**

- **OBTAIN A QUALIFIED TRAINING & LEGAL LICENSE FOR OPERATING OF THIS VEHICLE.**

- **A WELL AND PROFESSIONAL MAINTENANCE AND CERTIFICATED REPAIR SHOP TO ACQUIRE GOOD MECHANICAL CONDITIONS OF VEHICLE.**

Safe riding

- To check your vehicle before each ride is one of the key points to prevent an accident.
- please follow the maximum loads limited of operator and passenger.
- Most of accidents on the motorists are caused by automobile drivers who “failure to recognize out the vehicle” and caused mobile/motorcycle accidents.

Therefore making yourself conspicuous in the public will be very effective in preventing this kind of accidents

Therefore

- Wear a brightly colored protective suits/jacket.
- Operate the turning signals before turning and slow down the speed approaching and pass through the intersection.
- Keep proper distance with Motorists, and make them aware of your location.
- Know your skills and limits.
- Never lend your motorcycle to others who not qualified for riding it.
- Always follow the legal speed limit on the motorcycle and traffic law.

SAFETY INFORMATION

- The posture of operator and passenger is important for proper control. Properly riding posture can keep motorcycle in balance while riding.
- Operators should sit up right with two hands on the handle bar and feet on the floorboard while driving.
- Passengers should make sure that she/ he can firmly hold grip at operator and with feet on footrest.
- Driving after drinking alcohol or drug consumption or influencing medicaments is strictly prohibited.
- This motorcycle is designed for on road use only. It is not suitable for off road use.

Protective clothing

Proper/adequate clothing will keep yourself safe from potential accidents:

- Always wear an approved helmet with face shield to protect your eyes.
- The wearing of proper jacket, shoes, gloves reduce the degree of injury from unexpected accident.
- Never wear loose fitting clothes, otherwise they could catch on the control levers or wheels and can cause injury or accidents.
- Never touch the engine or exhaust system during or after driving as they become very hot and can cause burns. Always wear protective clothing that covers your legs, ankles, and feet.

Modifications

Modifications on the motorcycle which have not been approved by the producer or the removal of original parts may result in an unsafe vehicle condition and entail severe accidents and injuries. Not approved modifications make your motorcycle illegal.

Loading and accessories

The adding loading of accessories or cargo on to your motorcycle will influence the steering & balance of the vehicle. It may cause an accident so please be extremely carefully and consider the limitation when you equip it with accessories. Here are some guidelines referring loading cargo or adding accessories to your motorcycle.

SAFETY INFORMATION

Loading

The total weight of the operator the passenger the accessories and the cargo may not exceed the maximum load limit.

**Maximum payload
(do not include the vehicle):
150 kg**

When loading within this weight limit keep the following in mind:

- Cargo and accessory weight should be kept as low and close to the motorcycle as possible. Make sure to distribute the weight as evenly as possible on both sides of the motorcycle to minimize imbalance or instability.

- Make sure that accessories and cargo are securely attached to motorcycle.
- Never attach any large or heavy items to the handlebar the front fork or the front fender. Such items can create unstable handling or a slow steering response.

Accessories

Original accessories have been specifically designed for use on this motorcycle. Keep the following guidelines in mind, when mounting accessories.

- Never install accessories or carry cargo that would influence the ground clearance the suspension limit the steering or obscure lights and reflectors.
- Accessories on the handle bar will influence the steering of the motorcycle. If you install accessories please keep it light in weight.

- When you equip the motorcycle with electrical accessories please consult a qualified dealer to make sure that the items will not exceed the capacity of the electrical system. Unproven items or poor installation may cause a dangerous loss of electricity or short circuit or cable fire.

Gasoline and exhaust gas

- GASOLINE IS HIGHLY FLAMMABLE
- Always turn off the engine when refueling.
- Take care not to spill any gasoline on the engine or exhaust system when refueling.
- Do not smoke or use mobile phone while refueling.
- Never start the engine or let it run for any length of time in a closed area.

The exhaust fumes are poisonous and may cause loss of consciousness and death within a short time.

- Always turn the engine off before leaving the motorcycle and remove the key from the main switch. When parking the motorcycle please note the following:

- In case of swallowing any gasoline or gasoline getting into your eyes please consult a doctor immediately. Keep away the gasoline from your skin.

- The engine and exhaust system remain hot. Therefore park the motorcycle in a place where pedestrians or children are not likely to touch these hot areas.

- Do not park the motorcycle on a slope or a soft ground otherwise it can fall over.

- Do not park the motorcycle close to open or camp fire.

- Pay attention to the environment. Gasoline is not environmentally friendly.

Other safe driving points

- Turn the signal before making turns.

- When raining or driving across slippery area keep your speed slow. Take care while braking to avoid slipping or even fall down.

- Be careful when passing parked cars. Inattention to other road users can cause accidents.

Location of labels

You will find two different labels and the engine number on the vehicle.

The anti tampering plate (1) is located under the seat bench.

The VIN number plate (2) is located on the right side of the steering head tube.



The engine number (3) is stamped into the left engine cover.



Left view

1. Front wheel
2. Front brake caliper
3. Front turn signal light
4. Battery
5. Rear turn signal light
6. Rear wheel
7. Chain tensioner
8. Air filter element
9. Shift pedal



Right view

- 10. Tail/brake light
- 11. Muffler
- 12. Fuel tank cap
- 13. Seat
- 14. Spark plug
- 15. Rear view mirror
- 16. Headlight
- 17. Rear brake pedal



Operation instruments

- 18. Clutch lever
- 19. Left handlebar switches
- 20. Speedometer unit
- 21. Main switch/steering
- 22. Right handlebar switches
- 23. Throttle grip
- 24. Front brake lever

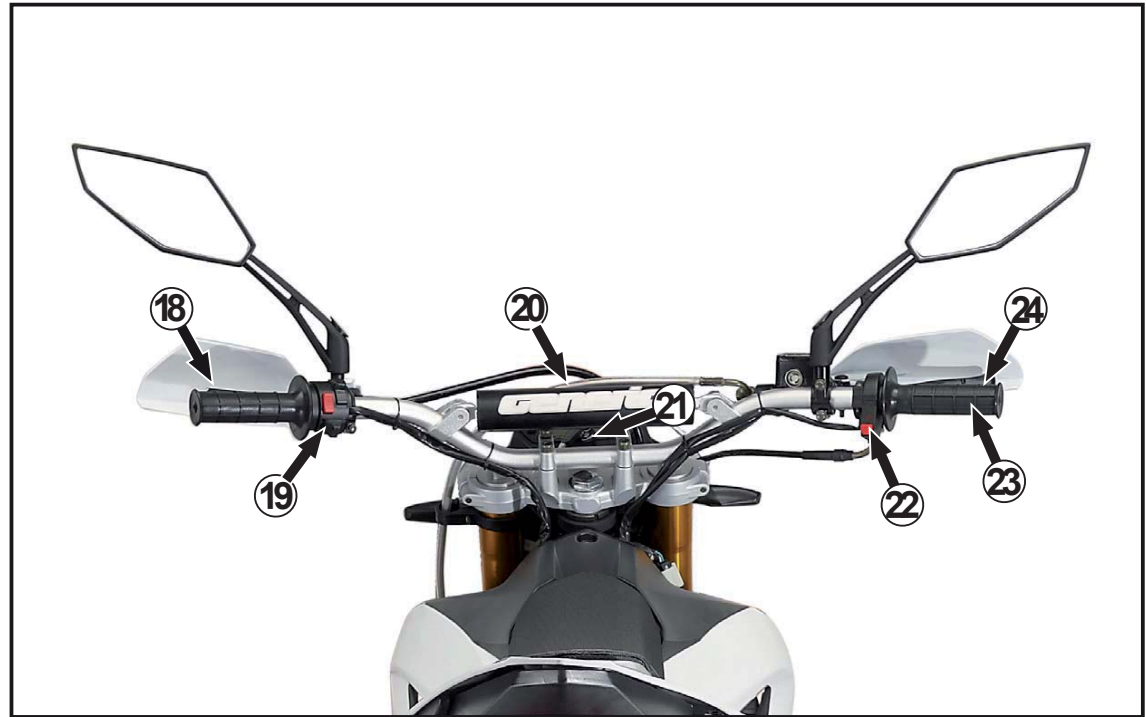

Main switch/steering lock



The main switch/steering lock controls the ignition and lighting systems and is used to lock the steering.

ON “”

All electrical circuits are supplied with power, and the engine can be started. The key cannot be removed.



OFF “”

The electrical systems are off. The key can be removed.

LOCK “”

The steering is locked, and the electrical systems are off. The key can be removed.





To lock the steering

1. Turn the handlebars all the way to the left.
2. Turn the key in from the “” position, and then turn it to “” while still pushing it.
3. Remove the key.

To unlock the steering

Push the key in, and then turn it to “” while still pushing it.

WARNING

Never turn the key to “” or “” while the vehicle is moving. Otherwise the electrical systems will be switched off which may result in loss of control or an accident. Make sure that the vehicle is stopped before turning the key to “” or “”.

OPERATION INSTRUMENTS

Indicator and warning lights









Speedometer

Display unit: km/h or mp/h



1. Display - Range: 0-199km/h or 0-124mp/h

Indicator lights

- 2. Neutral light **N** - Green
- 3. High beam light  - Blue
- 4. Direction light  - Green
- 5. Oil alarm  - Red
- 6. Temp. alarm  - Red
- 7. EOBD  - Orange

1. After the first 500km the oil alarm  will come on to remind for the first oil change.

Press the adjust button for 3 sec and the alarm light will turn off. After every 1000 km it will come again to remind checking the oil level.

2. In the normal condition when you switch on the ignition the EOBD  light will go on and after starting the engine some seconds later it will disappear. If there is (are) diagnostic trouble(s) after starting the engine the EOBD  will appear and blink in different diagnostic trouble codes. On the display you'll see the DTC Code. (DTC 1 - 1 failure, DTC 2- 2 failures,). Please contact a dealer as soon as possible to check the vehicle.

8. Odometer and trip meter

Odometer: Display range: 0-99999km or mile

Trip meter: Display range:

0-999.9km or mile

Display unit is 0,1km or mile.

9. Fuel meter

Display range is 6 levels. When the fuel is below the first bar, it will blink to remind for refuel.

10. RPM meter

The display range is 0-12000 rpm with minimum of 200 rpm.

Select button

Press the Select button less than 3 sec. to change the display colour from blue to orange and vice versa. Press the Select button more than 3 sec. the unit change between km/h and miles.

Adjust button

Press the Adjust button once to switch between ODO, TRIP, and CLOCK mode.

OPERATION INSTRUMENTS

1. Adjust button function instruction

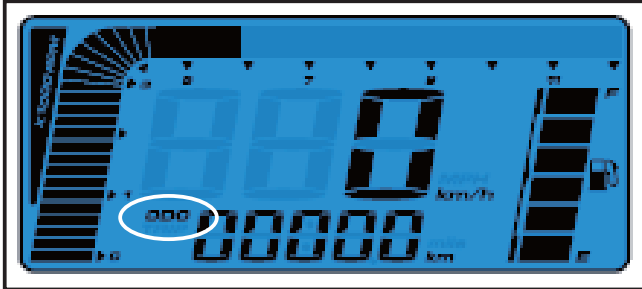

1.The main screen

In the main screen press the adjust button once to switch the function from odometer to trip.

When the odometer display range is over the Max it starts at zero. When the display range of trip meter is over the Max it will also start at zero automatically but it can also be reset manually by holding the adjust button for 3 sec under the trip screen.

In the main screen press and hold the adjust button for 3 sec to switch from km to mile.



2.The trip screen

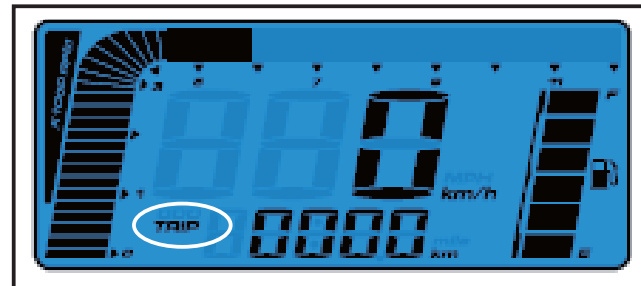

In trip screen press the adjust button once to switch from trip to clock. Press and hold the adjust for 3 sec to reset the trip.



3. The clock screen

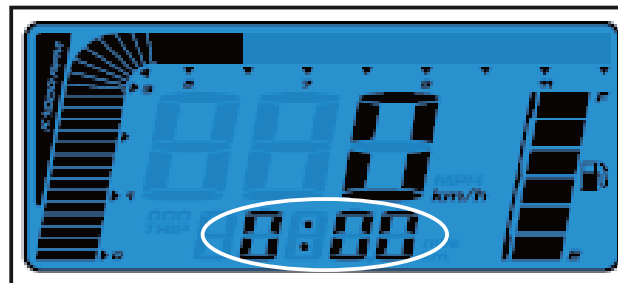

In clock screen press the adjust button once to switch from clock to the main screen.

4. Select button function instruction

In main screen press and hold the select button for 3 sec to switch the backlight color.

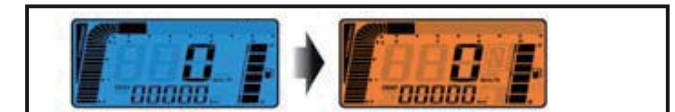

5. Enter the clock settings

In main screen press and hold the select and the adjust button for 3 sec to enter the clock settings.

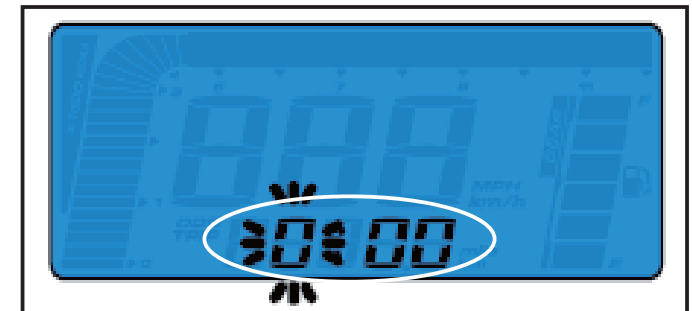

Example: You want to set the hour to 14h press the adjust button to choose the hour you want to set.



Example: You want to set the minute to 14:05 press the select button to enter the minute settings.





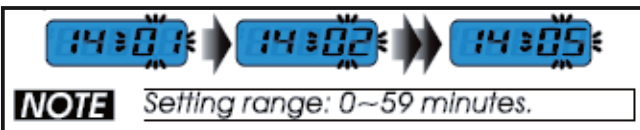



Then press the adjust button to choose the minute you want to set.

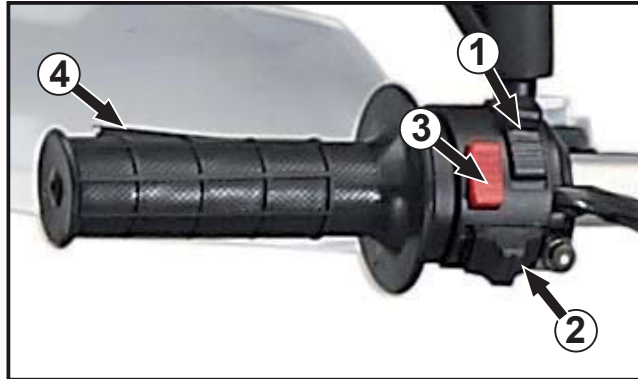

After the settings are done press the select button to store your settings and get back to the main screen.

Handlebar switches



1.  Light signal
-  Low beam switch
-  High beam switch
2.  Turn signal switch
3.  Horn switch
4.  Clutch lever

1. Light signal

When the switch is in the low beam position move the switch upwards to use the light signal. The switch will automatically return to the low beam position.

1. High/low beam switch

When the switch is in the low beam position move the switch downwards to use the high beam light. The switch will not return automatically to the low beam position.

2. Turn signal switch

Move the switch from the center position to the right to activate the right flasher light or move the switch to the left to activate the left flasher light. The switch will not return automatically to the center position.

3. Horn switch

The horn is sounded with this button.

4. Clutch lever

The clutch lever is fitted on the left side of the handle bar.

OPERATION INSTRUMENTS

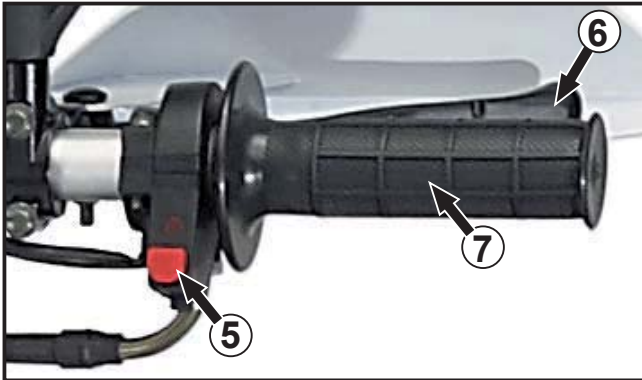

5.  Starter switch

5. Starter switch

Use the starter switch to operate the electric starter.

6. Hand/ front brake lever

The hand brake lever is fitted on the right side of the handle bar and refers to the front brake.

7. Throttle grip

The throttle grip can be used for the acceleration and the deceleration of the vehicle.

Rear/ foot brake pedal

The rear brake pedal is located on the right side of the vehicle and refers to the rear brake. Press down the brake pedal to activate the rear brake.



Shift pedal

The shift pedal is located on the left side of the engine. The position of the gears is shown in the illustration. The „N“ neutral gear is located between the first and the second gear.

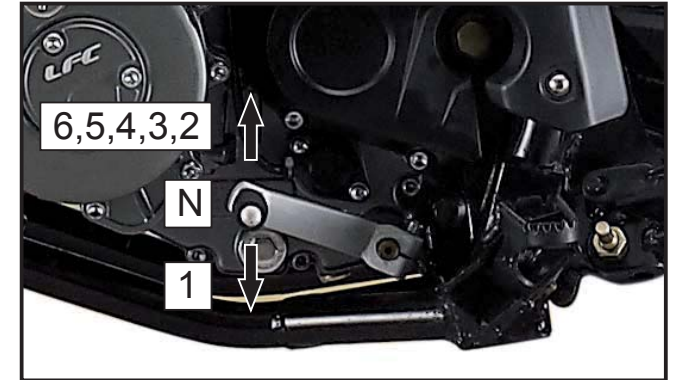

Fuel tank/ filler cap

The fuel tank and the filler cap are located under the seat bench. To reach the filler cap you must release the seatbench.



OPERATION INSTRUMENTS

Fuel/ fuel tank

Make sure that there is all the time sufficient fuel in the tank. To refuel the vehicle open the filler cap counterclockwise. Fill the fuel tank until the bottom of the filler tube. Do not overfill the fuel tank otherwise it may overflow.

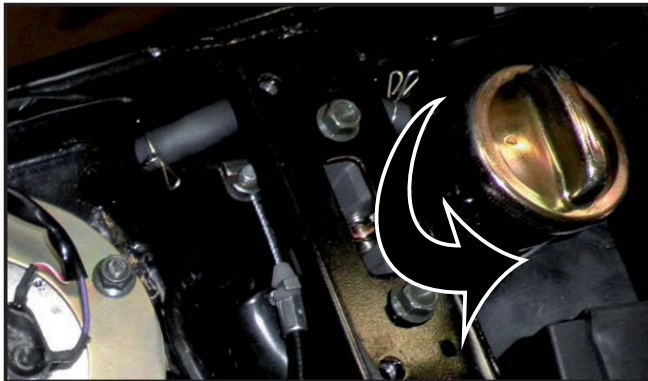

**Recommended fuel:
Unleaded gasoline
95 Octane or higher
Fuel tank capacity: 7.5 L ± 0.2L**

⚠ WARNING

It is not recommended to use E10 fuel. This can damage the engine and fuel system.

Immediately wipe off spilled fuel with a clean and dry soft cloth because fuel may destroy painted surfaces or plastic parts.

In case of swallow any gasoline or gasoline get into your eyes please consult a doctor immediately. Keep away the gasoline from your skin.

Seat

1. To open the seat
 - a) Place the motorcycle on the stand.

- b) Insert the key into the seat lock and then turn it clockwise to open.
- c) Now you can release the seat bench.



2. To close the seat
 - a) Fold the seat down and then push it down to lock it in place.
 - b) Remove the key from the seat-lock.

⚠ WARNING

Make sure that the seat is properly secured before riding.

OPERATION INSTRUMENTS

Engine oil

The oil level should be measured between the upper and the lower limit on the inspection glass (1) on the right side of the engine. To check the engine oil place the motorcycle in an upright position on a level surface.



Open the oil fill cap (2) to fill the recommended oil to the level between the upper and the lower limit. If the engine is cold the oil level should be visible near the lower level. If the engine is warm the level

should be visible at the upper limit. Add engine oil if necessary.

Recommended engine oil:
SAE 10W-40
Castrol Power 1 4T 10W-40
Capacity is 1.2L

⚠ WARNING

Never attempt to remove the oil fill cap just after high speed operation. The heated oil could spout out. Wait until the oil cools down.

Engine oil replacement

1. Start the engine and warm it up for several minutes.
2. Place the vehicle on even surface and hold it in upright position.
3. Place a suitable container under the engine.
4. Remove the oil drain bolt (3) and



clean the magnet from chips.

5. Remove the 3 screws (4) of the oil filter cover. Depollute the old Filter.

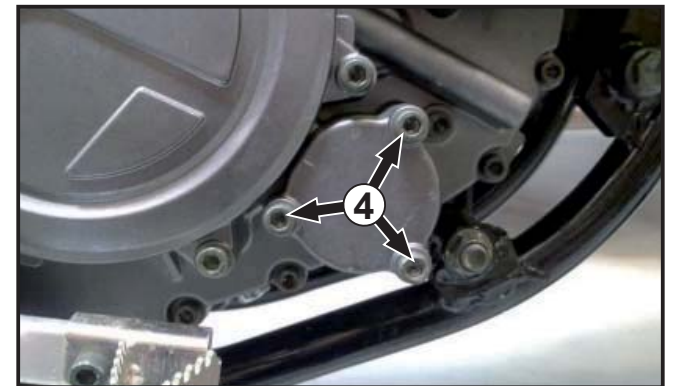

6. Remove the the oil strainer (5) screw. Blow up the strainer.

OPERATION INSTRUMENTS

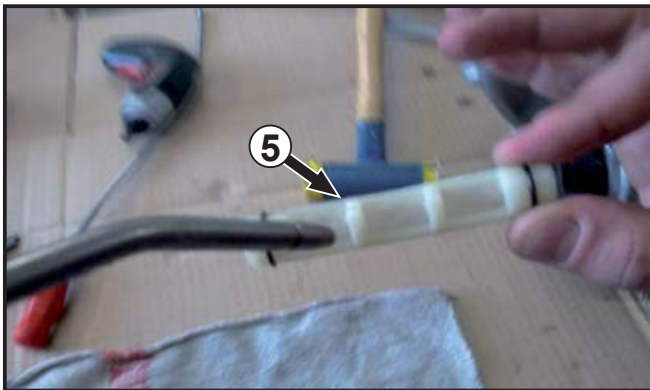
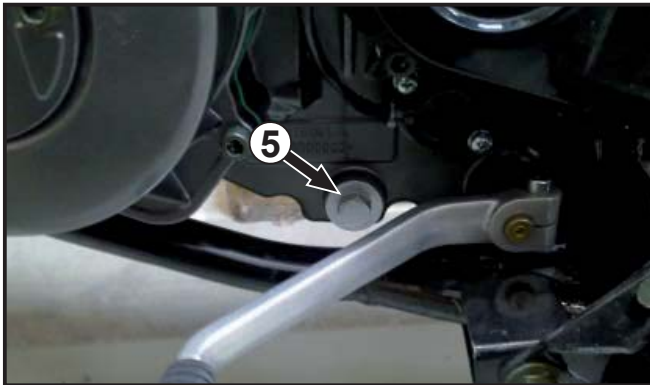

7. Assemble a new oil filter
8. Install the 3 cover screws again.
Use a new gasket
9. Install the oil strainer (5) with the screw again.
10. Install the oil drain bolt (3) with a new copper washer.
11. Refill engine oil: 1,2L

12. Install the oil filler cap (2).
13. Check the oil level

Side stand

The side stand is located on the left side of the frame.



Lower it with your foot while holding the motorcycle upright. The side stands is equipped with a auto-rebound system. To raise the side stand bring the motorcycle in a upright position. Pay attention to your legs when the side stand is soaring.

⚠ WARNING

Make sure that your motorcycle park stable. Please avoid to park the motorcycle on a precipitous or soft ground.

Catalytic converter

This model is equipped with a catalytic converter in the exhaust system.

⚠ WARNING

The exhaust system is hot after driving. Make sure that the exhaust system has cooled down before doing any maintenance work.

The following precautions must be observed to prevent a fire hazard or other damages.

- Never park the vehicle near grass or other materials that easily burn.
- Do not allow the engine to idle too long.
- Do not touch the exhaust after driving.

PRE-OPERATION CHECK

The condition of a vehicle is in the owner's responsibility. Vital components can start to deteriorate quickly and unexpectedly even if the vehicle remains unused (for example as a result of exposure to the elements). Any damage or fluid leakage or loss of tire air pressure can have serious consequences. Therefore it is very important to check the following points before each ride.

NOTE:

The pre-operation check should be made each time the vehicle is used. Such an inspection can be accomplished in a very short time and guarantee more safety.

WARNING

If any item in the pre-operation check list is not working properly have the vehicle fixed at an authorized dealer before operate it. If it failed to be corrected by yourself please contact your retailer.

PRE-OPERATION CHECK

Pre-operation check list

- Fuel**
 - Check the fuel level in the fuel tank.
 - Refill fuel if it is necessary.
 - Check the fuel line for leakage.
- Final transmission**
 - Check vehicle for oil leakage.
- Front brake**
 - Check operation.
 - If the brake feels soft or spongy have a dealer to check the system.
 - Check brake pads for wear and replace it if it is necessary.
 - Check the fluid level in reservoir and add brake fluid to if it is necessary.
 - Check hydraulic system for leakage.
- Brake lever**
 - Make sure that it works/operates smoothly.
 - Lubricate the lever pivoting points if necessary.
- Throttle grip**
 - Make sure that operation is smooth.
 - Check cable free play.
 - Lubricate cable and grip housing.
- Wheels and tires**
 - Check for damage.
 - Check tire condition and tread depth.
 - Check air pressure.
- Chasis fasteners**
 - Make sure that all nuts and bolts and screws are properly tightened.
 - Tighten it if it is necessary.
- Instruments and lights**
 - Check operation.

OPERATION AND IMPORTANT POINTS

Starting the engine

1. Turn on the ignition
2. Switch the gear to N - neutral
3. Actuating one of the brakes
4. Operate the starter button without accelerating
5. Let the side stand raise up

⚠ WARNING

Do not start the engine and allow it to idle in a closed room. Exhaust fumes are poisonous and can cause loss of consciousness and death. Provide always adequate ventilation while the engine is running.

CAUTION

- Maximum period for continuous starting is 5 seconds. Wait at least 5 seconds before trying it again.
- Don't ride your motorcycle with full load and don't over-rev the engine while it is cold as the piston warms up faster than the water will cool the cylinder.

- Always keep in mind that the engine should be warmed up with medium R.P.M. and small load.

Stop the Engine

1. Reduce the throttle to 0 position.
2. Pull the clutch lever
3. Switch the gear to N - neutral
4. Operate the brakes
5. After the vehicle is stopped turn off the ignition.

CAUTION

Before starting off allow the engine to warm up otherwise the spark plug and engine can be damaged early.

Starting off

1. Pull the clutch lever
2. Shift the engine to the first gear
3. Slowly release the clutch lever and open the throttle at the same time.

Shifting and riding

a) Shifting gears upwards

1. Release the throttle
2. Pull the clutch lever
3. Lift the gear lever upwards to change to the higher gears.
4. Slowly release the clutch lever and open the throttle at the same time.

b) Shifting gears downwards

1. Release the throttle
2. Operate the brakes and reduce the speed to a appropriate speed.
2. Pull the clutch lever
3. Lift the gear lever downwards to change to the lower gears.
4. Slowly release the clutch lever and open the throttle at the same time.

⚠ WARNING

Always switch one gear only, otherwise the transmission can be damaged.

OPERATION AND IMPORTANT POINTS

Acceleration and deceleration

The speed can be adjusted by opening and closing the throttle. To increase the speed turn the throttle grip in direction (a). To reduce the speed turn the throttle grip in direction (b).

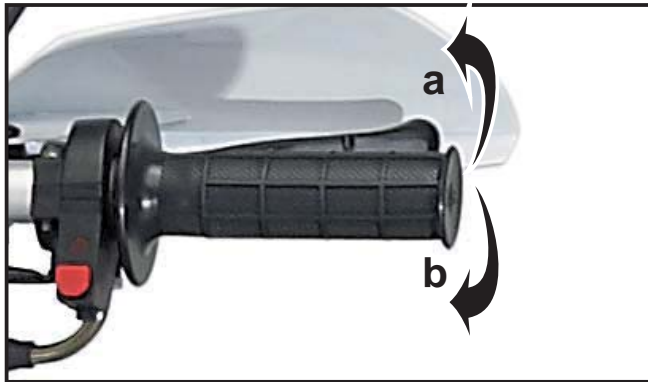

Braking

1. Release the throttle.
2. Apply the front and rear brake at the same time.
3. Apply the clutch lever gradually increasing the pressure.

⚠ WARNING

- **Avoid hard or sudden braking (especially when cornering) otherwise the motorcycle may skid.**
- **Railroad crossings, street-car rails, iron plates on road construction sites, and manhole covers become extremely slippery when wet. Therefore slow down when approaching such areas and cross them with caution.**
- **Keep in mind that braking on a wet road is much more difficult.**
- **Ride downhill slowly because braking downhill can be very difficult.**
- **When you brake, the brake discs, brake pads and the brake fluid heat up. The hotter these parts get, the weaker the braking effect. In extreme cases the entire braking system might malfunction.**
- **Take time to become familiar with the braking system.**

Engine break-in period

For the first 1500km driving do not rev the engine or make it exceed 80% of the maximum speed in any gear. It is recommended not to drive the motorcycle at full throttle.

Gear \ Distance	Speed limit (km/h)					
	1.	2.	3.	4.	5.	6.
0 - 300km	10	24	30	35	40	45
300 - 600km	15	30	35	40	45	50
600 - 1000km	15	30	40	45	50	60
1000 - 1500km	15	35	45	50	60	70

Top speed for the running-in period of the motorcycle

OPERATION AND IMPORTANT POINTS

Do not keep the engine run at the same speed long time during the running-in period. Often change it because it is helpful for the running-in of parts. During the running-in period it is necessary to put load on each part of the engine to guarantee complete coordination but do not over load the engine. Avoid also running the engine always at low speed.

During the running-in the engine always works at low speed the parts will get not in good condition. Accelerate the engine in any gear but do not exceed the suggested limit. Do not accelerate the motorcycle to full throttle during the running-in period.

First inspection and routine maintenance

The inspection immediately after the first 1000 km is the most important one. This inspection shall be done comprehensively. Every fastening piece shall be refastened and the engine oil must be replaced.

CAUTION

After the first 1000 km the final engine oil and the oil filter must be changed, the oil sieve and the oil drain bolt must be cleaned.

If any engine problem occur during the running-in period immediately consult your dealer to check the vehicle.

Parking

1. Reduce the throttle to 0 position.
2. Pull the clutch lever
3. Switch the gear to N - neutral
4. Operate the brakes
5. After the vehicle is stopped turn off the ignition.
6. Lower the side stand with your foot while holding the motorcycle upright. Remove the key from the main switch.

⚠ WARNING

The exhaust system is hot after driving. Make sure that the exhaust system has cooled down before doing any maintenance work. The following precautions must be observed to prevent a fire hazard or other damages.

- **Never park the vehicle near grass or other materials that easily burn.**
- **Do not allow the engine to idle too long.**
- **Do not touch the exhaust after driving.**

CHECKING/ MAINTAINING SERVICE INTERVALS

The Safety and condition of motorcycle depend on a correct maintenance, periodic inspection, adjustment, lubrication and cleaning. The following contents help the operator to complete this tasks.

During the warranty period all repair and recommended service inspections have to be done by an authorized dealer.

WARNING

Not authorized manipulation on the motorcycle leads to the loss of warranty.

If you are not familiar with maintenance work have a dealer to do it for you.

The vehicle has to be checked for rust constantly. The owner is responsible for rust prevention. The drive chain must be cleaned and lubricated regularly.

The airfilter needs more frequent service if you ride in unusually wet or dusty area.

CHECKING/ MAINTAINING SERVICE INTERVALS

The inspection intervals are required, otherwise, no guarantee can be granted		1000 km or 1. month	4000 km or 6. month	7000 km or 12. month	10000 km or 18. month	13000 km or 24. month
PART	TO DO					
Air filter	clean/ exchange	✓	✓	E	✓	✓
Wheels, rims	Control	✓	✓	✓	✓	✓
Tires	Control/ tire pressure		✓	✓	✓	✓
Wheel bearing	Control/ exchange		✓	✓	✓	✓
Steering bearing	Control/ clean/ lubricate	✓	✓	✓	lubricate	✓
Screws Coverparts	Control/ tighten		✓	✓	✓	✓
Brake system	Control/ clean/ exchange		✓	✓	✓	✓
Main stand	Control/ clean/ lubricate		✓	✓	✓	✓
Front forke	Control		✓	✓	✓	✓
Rear suspension	Control		✓	✓	✓	✓
Oil filter	Clean	E		✓		✓
Engine oil	Control/ exchange	E	✓	E	✓	E
Valves (Engine)	Control/ adjust	✓	✓	✓	✓	✓
Transmission oil	Exchange	EE		E		
Variomatic belt	Control/ exchange		✓	E	✓	
Fly wheels	Control/ exchange		✓	E	✓	
Driven chain/ sprokets	Control/ clean/ exchange	✓	✓	✓	✓	✓
Clutch	Control	✓	✓	✓	✓	✓

CHECKING/ MAINTAINING SERVICE INTERVALS

Cable/ bowden	Control/ clean/ lubricate	✓	✓	✓	✓	✓
Throttle	Control/ adjust/ lubricate		✓	✓	✓	✓
Lights/ switches	Control/ adjust	✓	✓	✓	✓	✓
Fuel line/ fuel filter	Control/ exchange		✓	E	✓	✓
Idle speed	Control/ adjust	✓	✓	✓	✓	✓
Exhaust system	Control/ tighten		✓	✓	✓	✓
Coolant	Control	✓	✓	✓	✓	✓

Important Information

- Brake lines have to be exchanged at least every 4 years.
- Brake liquid has to be exchanged at least every 2 years.
- Starting at 13000 km the maintenance should be done every 3000 km or annually.
- The vehicle must be constantly checked for rust. The owner himself is responsible for rust protection.
- The drive chain must be cleaned and lubricated regularly.
- The air filter needs more frequently service If you ride in unusually wet or dirty area.

Recommended Supplies and maintenance products:

Fuel: Unleaded gasoline - 95 Octane or higher

Engine oil: SAE 10W-40 - Castrol Power 1 4T - Capacity is 1.2L

Coolant: Castrol Motorcycle coolant

Brake fluid: DOT 4 - Castrol Motorcycle brake fluid

Multi-purpose lubricant: Castrol Motorcycle DWF

Chain Spray: Castrol chain spray O-R

Spark plug

The spark plug is an important engine component which is easy to check. Since heat and deposits will cause any spark plug to slowly erode the spark plug should be removed and checked in accordance with the periodic maintenance and lubrication chart. In addition the condition of the spark plug can reveal the condition of the engine.

Spark plug type: CR8ES
Tightening torque: 10 - 15Nm
Spark plug gap: 0.6 - 0.7mm

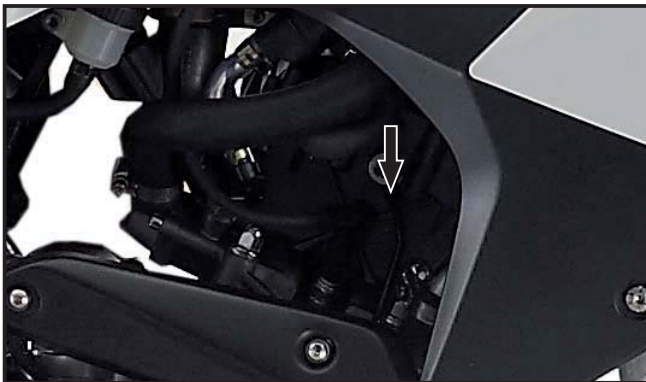

Air filter

The air filter element (1) should be cleaned and replaced regarding the service intervals. Clean the air filter element more frequently if you are riding in unusually wet or dusty areas.

1. Open the seat bench.
2. Remove the left and right front coverparts.
3. Dismantle the screw of the air box cover.
4. Remove the air filter element.
5. Blow out the air filter carefully with compressed air.
5. Reassemble in reverse order.



⚠ WARNING

Never install a wet air filter element this will damage the engine. If the air filter can not be dry cleaned use special cleaner from the dealer or replace the air filter.

Oil drain pipe

It should be checked regularly if needs drain oil.

To drain the oil as follow:

1. Put a suitable container below the oil drain pipe.
2. Loosen the clamp and move it upward.
3. Pull out the drain plug and drain the oil.
5. Insert the drain plug and move down the clamp to fasten.



CHECKING/ MAINTAINING

Coolant inspection

Before starting the engine, place the bike on a level place and hold it in an upright position, then open the cap of the radiator to inspect the coolant level.

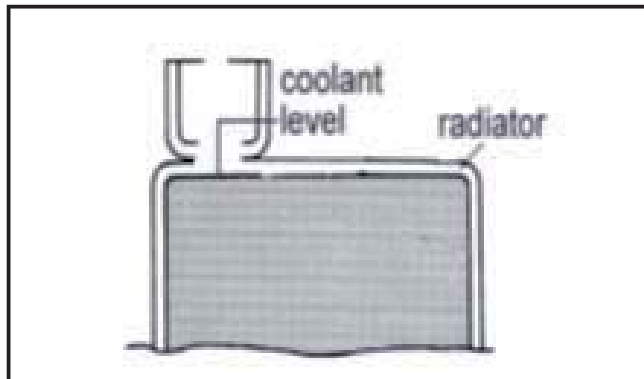

From the left side you can inspect the level of the expansion tank.

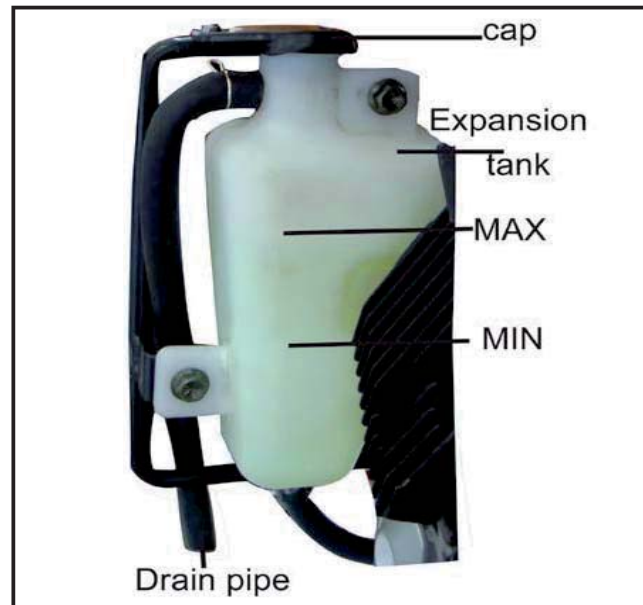

⚠ WARNING

Do not remove the radiator cap and expansion tank cap when engine and radiator are hot. Scalding hot fluid and steam may be blown out under pressure, which could cause serious injury.

Bleeding the coolant system

1. Open the radiator cap.
2. Place a small container under the bike.
3. Open the hose clamp (1) and let the fluid bleed in the container.
4. Open the hose clamp (2) and let the fluid bleed.
5. Open the 3 screws (3) from the water pump cover only a little bit to bleed the pump.
6. Install all screws again and refill the system.

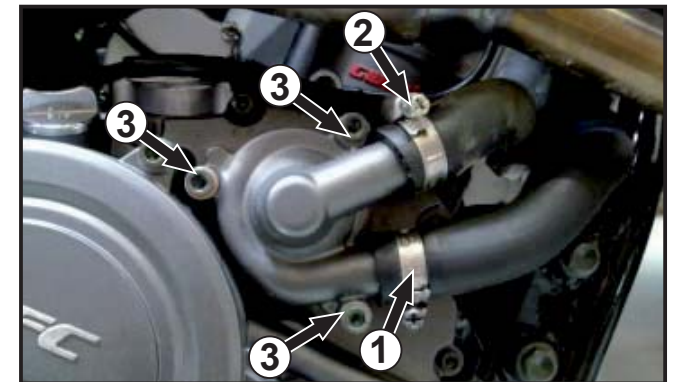

**Recommended coolant:
CASTROL
MOTORCYCLE COOLANT**

ECU (Engine Control Unit)

The ECU is installed on top of the air box, under the front cover. According to the pre-set control procedures and parameters, ECU controls fuel injection, ignition timing precisely, enabling the engine working optimally under various working condition, at the same time minimizing the tailpipe emissions and fuel consumption. When the system detects fault(s), the ECU also provides diagnosis when system malfunctions occur by outputting trouble code according to EOBD.



The ECU is one of the most important parts of the vehicle and it is adjusted properly during manufacturing. If you have any problem please contact a dealer for consultation.

Each ECU is identified with a product label for traceability, it should not be defaced or soiled or the manufacturer shall not be hold responsibility of investigation and replacement.

Keep the ECU clean, by a dry cloth. Keep the ECU and connectors away from water, fuel or other corrosive liquid which may damage the housing of the ECU.

Adjust the idling

If the idle is not correct consult a dealer to check it. The minimum speed of the engine (idling) must be approximately 1700 ± 100 rev/min.

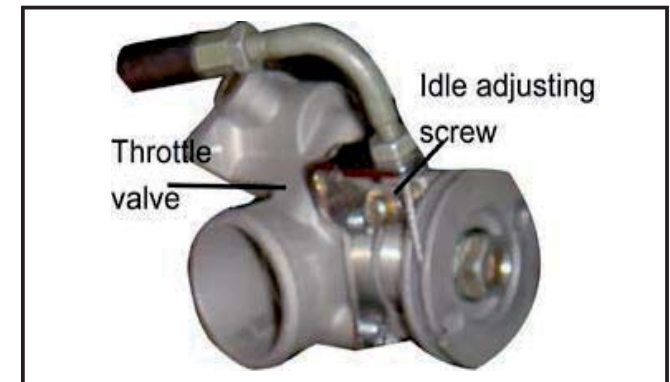

Checking the throttle cable free play

1. Release the locknut (1)
2. Rotate the adjusting screw (2) to adjust the clearance.
3. Tighten the lock nut 1 after adjusting the nut 2.

The throttle cable free play should measure 1.5 ~ 3.5 mm at the throttle grip.

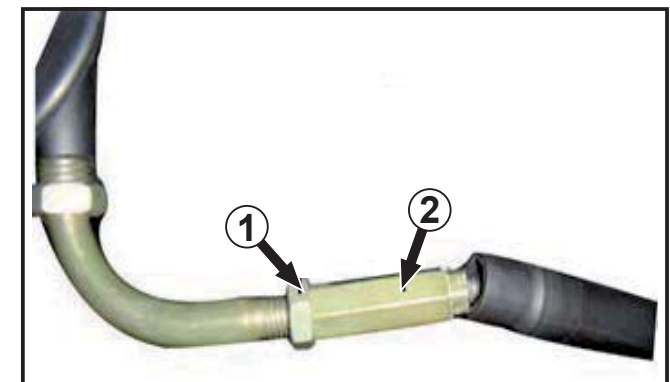

Clutch adjustment

1. Loosen the locknut (1) on the crank case.
2. Turn the adjusting bolt (2) in or out to meet the requirements of clutch free play.
3. The free play should be 10-20 mm on the clutch lever.
4. Tighten the lock nut (1) after adjusting the nut (2).

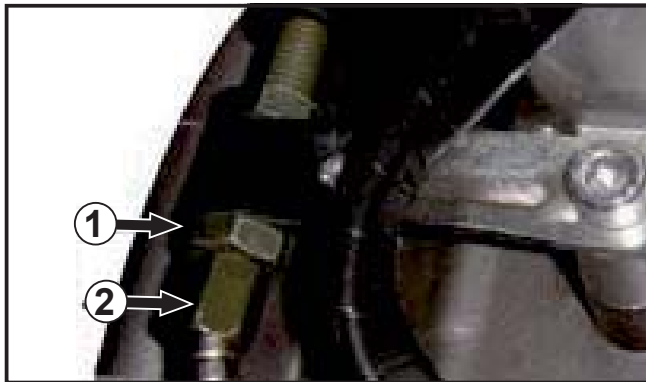

Tires

To maximize the performance, durability, and safe operation of your motorcycle, note the following points regarding the specified tires.

CAUTION

The tire air pressure should be checked and adjusted before each ride. The tire air pressure must be checked and adjusted on cold tires.

Tire air pressure:

Driver only -

Front: 2,1 bar - Rear: 2,2 bar

With passenger and max. payload

Front: 2,1 bar - Rear: 2,5 bar

⚠ WARNING

Do not overload your motorcycle, instead the tire pressure will decrease.

Allocation of your cargo and the total weight of your vehicle is very important for your own safety and vehicle performance. When you do not load your cargo firmly on vehicle it may lead to an accident.

Put the heaviest cargo to the center of motorcycle then distribute the weight evenly from side to side. This will ensure proper handling of the vehicle.

Tire inspection

1. Tire tread depth (min. 1,6 mm)
2. Tire sidewall
3. Tire wear indicator

CAUTION

The tires must be checked before each ride. If a tire tread shows crosswise lines (minimum tread depth), or if the tire has a nail or glass fragments in it, or if the sidewall is cracked, contact a dealer to replace the tire immediately.

The tire treads depth limits may differ from country to country. Always comply with the local regulations.

CHECKING/ MAINTAINING

⚠ WARNING

To operate the motorcycle with worn tires decrease riding stability and can lead to loss of control. Please replace the worn tires by new one immediately.

Front tire size:

100/80-17-52H (2.5X17 wheelrim)

Rear tire size:

130/80-17-65H (3.0X17 wheelrim)

Cast wheels

To maximize the performance, durability, and safe operation of your motorcycle, note the following points regarding the specified wheels.

CAUTION

The wheel rims should be checked for cracks, bends or warpage before each ride.

If any damage is found, contact a dealer to replace the wheel. Do not attempt even the smallest repair to the wheel a deformed or cracked wheel must be replaced.

The wheel should be balanced whenever either the tire or wheel has been changed or replaced. An unbalanced wheel can result in poor performance, adverse handling characters, and a shortened tire life. Ride at moderate speeds after changing a tire since the tire surface must first be “break in” for it to develop its optimal characteristics.

Front brake

CAUTION

There should be no free play at the brake lever end.

If there is free play, contact a dealer to inspect the brake system.



⚠ WARNING

A soft or spongy feeling in the brake lever can indicate the presence of air in the hydraulic system. If there is air in the hydraulic system, have a dealer bleed the system before operating the motorcycle. Air in the hydraulic system will diminish the braking performance, which may result in loss of control and an accident.

Front brake free play adjustment

1. Loosen the locknut (1)
2. Turn the adjusting bolt (2) until specified position (10-20 mm freeplay on the lever)
3. Tighten the locknut again.

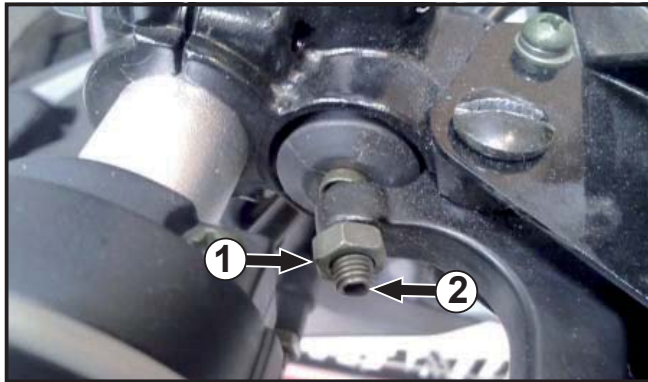

⚠ WARNING

After adjusting make sure that the break pads do not drag. When there is no free play on the lever the pressure in the brake system will increase and the system can over-heat and fail. If proper adjustment cannot be obtained as described, contact a dealer to make this adjustment.

Rear brake

CAUTION

There should be no free play at the brake lever end. If there is free play contact a dealer to inspect the brake system.

⚠ WARNING

A soft or spongy feeling in the brake lever can indicate the presence of air in the hydraulic system. If there is air in the hydraulic system, have a dealer bleed the system before operating the motorcycle. Air in the hydraulic system will diminish the braking performance, which may result in loss of control and an accident.

Rear brake free play adjustment

1. Loosen the locknut (1)
2. Turn the adjusting bolt (2) until the lever position is within specified position (10-20 mm free play on the lever)
3. Tighten the locknut again.

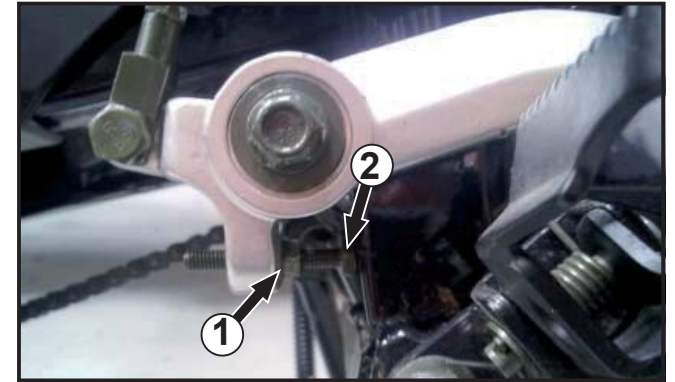

⚠ WARNING

After adjusting make sure that the break pads do not drag. When there is no free play on the lever the pressure in the brake system will increase and the system can over-heat and fail.

If proper adjustment cannot be obtained as described contact a dealer to make this adjustment.

CHECKING/ MAINTAINING

Brake pads

The front and rear brake pads must be checked for wear in periodical intervals.

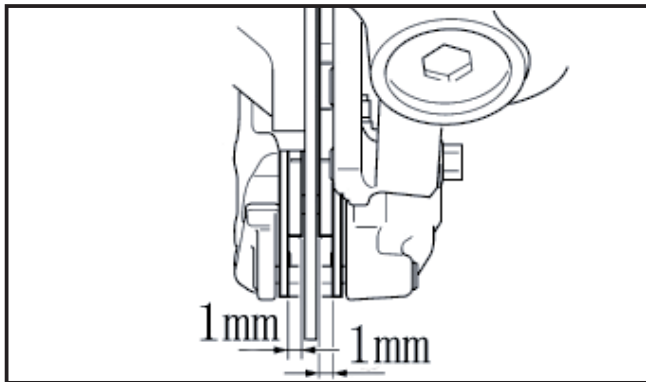

⚠ WARNING

Check brake pads for wear, especially before every trip. The pads present a groove that must always be visible. Disc brake pads wear depends on use riding style and road conditions. If the friction material of the pads reach the 1 mm thickness limit change both pads. The excessive wear of the friction material would cause the contact of the pad metal support with the

disc with consequent metallic noise and production of sparks from the caliper. Braking efficiency, safety and soundness of the disc would thus be negatively affected.

Checking the front and rear brake fluid level

Place the vehicle that the master cylinder is in horizontal position. If the brake fluid is below the minimum level mark please refill up to the max indication. Insufficient brake fluid may allow air to enter the brake system possibly causing it to become ineffective. Low brake fluid level may indicate worn brake pads or brake system leakage.



CAUTION

Use only the recommended quality brake fluid otherwise the rubber seals may deteriorate causing leakage and poor braking performance.

Refill with the same type of brake fluid. Mixing fluids may result in a harmful chemical reaction and lead to poor braking performance. Brake fluid deteriorate painted surfaces or plastic parts. Always clean up spilled fluid immediately. As the brake pads wear the brake fluid level to gradually go down.

**Recommended brake fluid:
DOT 4 - CASTROL
MOTORCYCLE BRAKE
FLUID**

Changing the brake fluid

Contact a dealer to change the brake fluid at the intervals specified in the periodic maintenance and lubrication chart.

Checking the lubrication of the cables

The operation of all control cables and the condition of the cables should be checked before each ride and the cables and cable ends should be lubricated if necessary. If a cable is damaged or does not move smoothly contact a dealer to check or replace it.

**Recommended multi-purpose lubricant:CASTROL
MOTORCYCLE DWF**

⚠ WARNING

Damage to the outer housing of cables may result in internal rusting and cause interference with cable movement. Replace damaged cables as soon as possible to prevent dangerous wear of the cables.

Front fork

Checking the front fork

The condition and operation of the front fork must be checked as follows:

1. Place the motorcycle on a level surface and hold it in an upright position.
2. While applying the front brake push down hard on the handlebars several times to check if the front fork compresses and rebounds smoothly.

⚠ WARNING

If any damage is found or the front fork does not operate smoothly, contact a dealer to check or repair it.

Checking the steering

Worn or loose steering bearings may cause danger.

Therefore the operation of the steering must be checked as follows at the intervals specified in the periodic maintenance and lubrication chart.

Place a stand under the engine to raise the front wheel off the ground. Hold the lower ends of the front fork legs and try to move them forward and backward. If any free play can be felt, contact a dealer to check or repair the steering.

⚠ WARNING

Securely support the motorcycle so that there is no danger for it for falling over.

CHECKING/ MAINTAINING

Checking the wheel bearings

The front and rear wheel bearings must be checked at the intervals specified in the periodic maintenance and lubrication chart.

CAUTION

If there is free play in the wheel hub or if the wheel does not turn smoothly have a dealer check the wheel bearings.

Chain adjusting

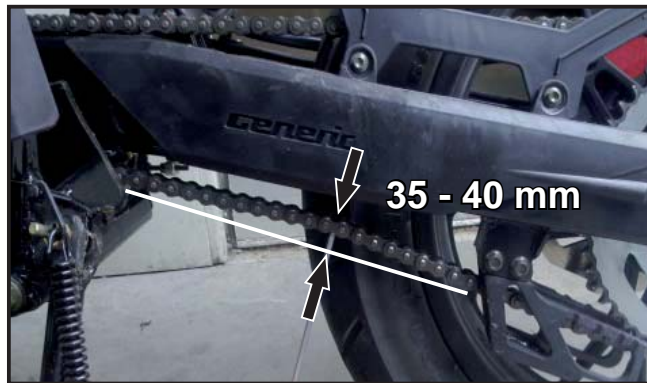

WARNING

If the chain tension is too great, parts within the secondary power

transmission (chain, chain sprockets transmission and rear wheel bearings) will be subjected to unnecessary stress resulting in early wear and even chain breakage. Too much slack in the chain, on the other hand, can result in chain jumping off the chain wheels. If this happens the chain could also block the rear wheel or damage the engine. In either case the operator is likely to lose control of the motorcycle.

Adjust the chain Tension

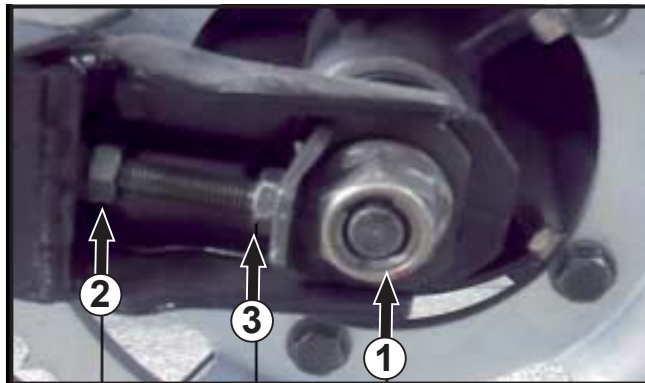

1. Loosen collar nut (1)

2. Loosen counter nuts (2)
3. Turn right and left adjusting screws (3) equally far.
4. Tighten counter nuts (2).

Before tightening the wheel spindle, verify that the chain adjusters are sitting close to the adjusting screws and that the rear wheel has been aligned with the front wheel. Tighten collar nut (1) with 70 Nm.

Shock absorber

The shock absorber is equipped with a preload adjuster. The shock absorber's preload adjuster is infinitely variable. This allows the shock absorber to be adapted to match your body weight and the payload.



CHECKING/ MAINTAINING

Adjust the preload

Turn the adjusting ring (1):

- clockwise to increase the preload
- counterclockwise to decrease the preload

⚠ WARNING

The shock absorber is filled with high density nitrogen. Do not disassembly the shock Absorber. This may lead to injury.

Battery

The battery is installed under the seat inside of the air filter box.



For any replacement please release the screws form (1, 2 and 3) on On both sides of the vehicle and screw (4) and (5) from the top cover.

After this take off the plastic covers. The air filter box is exposed.

Release the screws around the air box. You can see air filter element. Remove the caliper connecting it with the throttle body to remove the element.

Now the battery is accessible.



CAUTION

The battery model (YTZ7-S) is a sealed type (MF) battery which does not require any maintenance.

⚠ WARNING

Electrolyte is poisonous and dangerous it contains sulfuric acid which causes several burns.

Avoid any contact with skin, eyes or clothing. Protect your eyes when you handle a battery. In case of contact flush with plenty of water.

In case of eyes contact flush with plenty of water and seek immediate medical attention.

Batteries produce explosive hydrogen gas. Therefore keep sparks, flames, cigarettes, etc. away from the battery.

Provide sufficient ventilation when charging the battery.

KEEP ALL BATTERIES OUT OF THE REACH OF CHILDREN

Charging the battery

1. Switch off all consumers.
2. Measure the battery voltage using a multimeter.
Fully charged: ~ 13,8V
3. If the voltage is below 12V disconnect the minus wire from the battery.
4. Connect a suitable charger.

To store the battery

If the vehicle will not be used for a longer period remove the battery and recharge it. If the battery will be stored for a longer period check it at least once a month and fully recharge it if necessary.

After installation make sure that the battery leads are properly connected to the battery terminals. When recharging the battery make sure the amper and volts of charger is suitable to the battery and the specific type.

CAUTION

If you are not familiar with battery charging please contact a dealer. Storing a discharged battery can cause permanent battery damage. Store the battery only in a cool dry place.

Replacing the fuse

The fuse holder is located in the air-box. If a fuse is blown then replace it as follows.



1. Turn off the main switch.
2. Remove the blown fuse and

install a new fuse of the specified amperage.

3. Turn on the electrical circuits to check if all devices operate correctly.

CAUTION

If the fuse blows once again contact a dealer check the electrical system.

Fuses:
15 A (blue)/ 20 A (yellow)

Replacing the headlight bulb

1. If the headlight bulb does not glow remove the bolts and screws (1 to 4) to disassemble the head lamp assembly.
2. Take out the rubber dust cover (5) and the pug (6) then turn the fixing disc (7) anti-clockwise to take it out before replacing the bulb (8).

CHECKING/ MAINTAINING

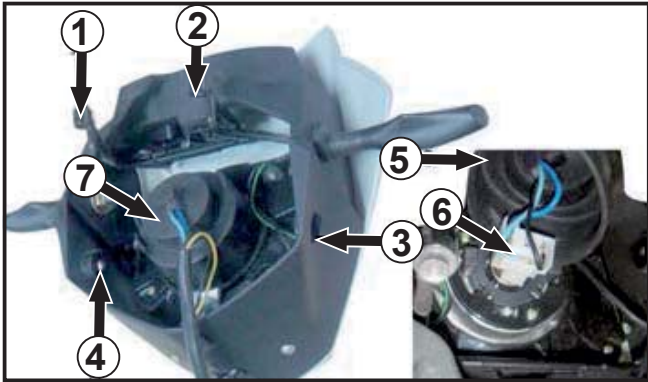

When you need to adjust the headlight turn in or turn out the adjusting screw (9).

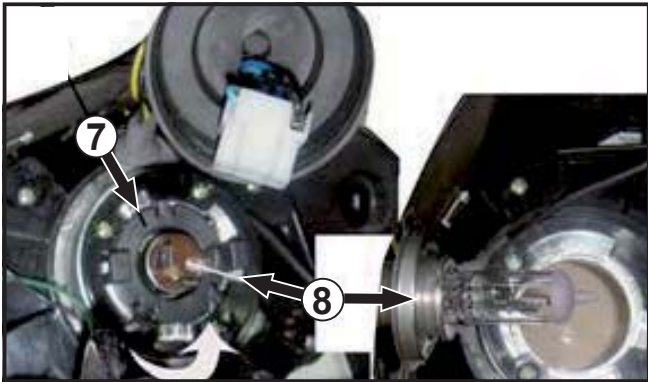

Front and rear turn signal lamp

If the front or rear turn signal light (10) does not glow contact a dealer to check the electrical circuit or to replace the lamp.

Tail/brake light and license plate lamp

If the tail/brake light (11) and the license plate light (12) do not glow disassemble the bolts (1 and 2) for

changing the bulb.

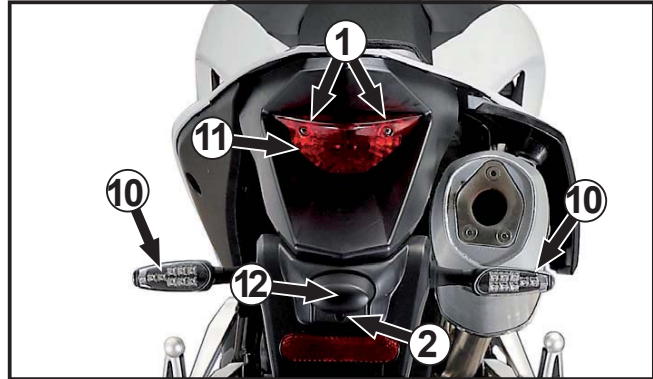

Injection system

The injection system consists of a fuel pump with tubes, a fuel filter, and the injector.

CAUTION

Fuel pipes should not be bent, curved or compressed.

Fuel pump

The fuel pump module supplies fuel to the engine at system pressure.

The fuel pump module is mounted inside of the fuel tank.

Fuel filter

The fuel filter protects the engine and the injector against impurity from fuel.

CAUTION

The fuel filter should be changed from by dealer.

Injector

The injector is controlled by ECU timely and accurately injecting the fuel into the inlet manifold.

Troubleshooting

Although our company's motorcycles receive a thorough inspection before shipment from the factory trouble may occur during operation. The following trouble shooting chart represents a quick and easy procedure for checking these vital systems by yourself.

However should your motorcycle require any repair contact an authorized dealer who is a skilled technician. He has the necessary tools, experience and know how to service the motorcycle properly.

CAUTION

Use only genuine spare parts.

TROUBLESHOOTING

FAILURE	Cause	To Do
Engine does not start when the electric starter button is pushed	Battery discharged	Charge the battery
		Check the charging of the battery Check if the generator is working correctly
	Fuse is blown	Change the fuse
	Starter relay defective	Check the starter relay
	Starter motor defective	Check the starter motor
	Wrong assembly of roll over sensor	Check roll over sensor position
Engine turns but does not start or dies off	A fuse is blown	Check the fuses
	Idle speed is not set correctly	Adjust the idle speed
	Spark plug is contaminated	Clean the spark plug, check the electrode distance
	Failure in ignition system	Check the ignition system
	Wire harness is worn	Check the wiring harness
	Contact problem in a plug	Check the plugs of the wiring harness
	No gasoline in the tank	Refill gasoline
	Problem with the fuel pump	Check the pump
	Problem with the fuel filter	Check the filter
Fuel leakage	Check the fuel circuit	
Engine power is poor	Air filter contaminated	Clean the filter
	Fuel filter contaminated	Clean the filter
	Failure in fuel system	Check the fuel system
	Problem with the ignition system	Check the ignition system
	Valve clearance too little	Adjust valve clearance
Engine overheats	No or not enough coolant in the system	Refill coolant
	Coolant leakage	Check the colland circuit
	Air in the coolant system	Ventilate the system
	Thermostat damaged	Replace Thermostat

TROUBLESHOOTING

FAILURE	Cause	To Do
To high oil consumption	Engine oil level too high	Bleed the oil system
	Cylinder/Piston is worn	Replace the cylinder/piston
	Engine vent hose bent	Correct the layout of the hose
EOBD alarm light is on and DTC appears on the speedometer	Failure in the fuel injection/electric system	Stop the motorcycle and identify the faulty part by pushing the Select Button on the speedometer
		Check the wiring harness for any damage
		Use the diagnostic tool to erase the DTC

Cleaning

CAUTION

Clean the motorcycle in a proper and suitable way. It will keep it attractive, extend it's life and optimize the performance.

Before cleaning

Cover the muffler outlet and the two airbox inlet holes with a plastic bag or cap to prevent water to come inside. Close every caps, covers and electrical connectors while you are doing the cleaning. We do not suggest to use any acidic cleaners for cleaning. If such products have been used on hard to remove dirt please only do the spot cleaning and use water afterwards. Then dry it and use corrosion protection spray after finishing.

Please only use mild detergent and water to clean plastic covers, panels, headlight lenses, meter lenses, etc. After cleaning, use only a soft, clean cloth or sponge to dry the plastics.

Please prevent any harsh chemical products (like fuel, rusty removers, break fluid...) on plastic parts especially on painted covers, lens and wind shield. It will damage them and even cause safety consideration. Do not use high pressure washer, steam cleaner since it will cause water seepage and deterioration on bearings, electric components as connectors and switches, lights, breathe hose and tube, brake shoes and pads and seals.

Sea salt or salt sprayed on the roads during winter are extremely corrosive.

After riding in the rain, near the sea or on salt-sprayed roads:

Clean the motorcycle with cold water and a mild detergent after the engine has cooled down. Apply a corrosion protection spray on all metal, including chrome-plated and nickel-plated surfaces to prevent corrosion.

Do not use warm water since it increases the corrosive action of the salt.

After cleaning

Dry the motorcycle with a absorbing cloth. To prevent corrosion it is recommended to apply a corrosion protection spray on all metal including chrome- and nickel-plated surfaces. Use spray oil as a universal cleaner to remove any remaining dirt. Wax all painted surfaces.

CLEANING/ STORAGE

Make sure that there is no oil or wax on the brakes or tires. If necessary clean the brake discs and brake linings with a regular brake disc cleaner and wash the tires with warm water and a mild detergent.

⚠ WARNING

Before operating the motorcycle test the brake performance and tires.

Storage

Always store your motorcycle in a cool dry place and protect it against dust with a motorcycle cover. Please store the motorcycle in a well air flow room with dry air. A storage with high humidity will cause rust. To prevent corrosion avoid damp cellars stables (because of the presence of ammonia) and areas where strong chemicals are stored.

Follow all the instructions in the “Cleaning” section of this chapter. Fill the tank and pour some additive in. The quality of the fuel will stay constant.

Lubricate all cables and the pivoting points of all levers and pedals. Check and if necessary correct the tire air pressure and then lift the motorcycle so that both wheels are off the ground.

Cover the muffler outlet with a plastic bag to prevent moisture entering it. Remove the battery and fully charge it. Store it in a cool dry place and charge it once a month. If the machine is to be stored in a humid or salt-air environment coat all exposed metal surfaces with a film of light oil. Do not apply oil to rubber parts or the seat cover. Make any necessary repairs before storing the motorcycle.

Recommended maintenance products:

CASTROL GREENTEC BIKE CLEANER

CASTROL BIKE POLISH

CASTROL CHAIN SPRAY O-R

CASTROL MOTORCYCLE DWF

SPECIFICATION

TR 125

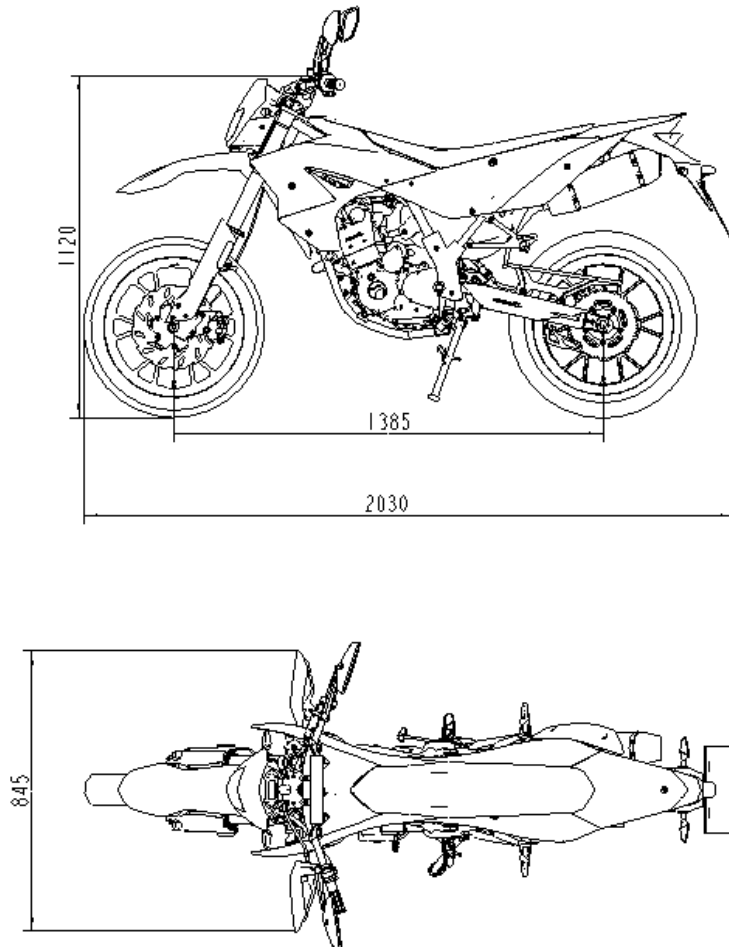

Model		TR 125		Engine	Engine type	QJ 160 MI - A
Overall Length (mm)		2030			Fuel type	95 octane unleaded gasoline
Overall Width (mm)		845			Number of cylinders	1
Overall height (mm)		1120			Bore*stroke	Φ 60 mm *44 mm
Wheelbase (mm)		1385			Displacement	124.4
Vehicle Weight (kg)	Front axle	63 kg			Starting mode	Electric
	Rear axle	76 kg			Cooling mode	Water cooled
	Total	139 kg			Lubricating mode	Force-feed and splash lubrication
Wheel Specification		Front (External)			Oil tank capacity	1.2 L (Oil change 1 L)
		100/80-17			Air cleaner	Filter sponge
		Rear (External)		Fuel tank capacity	7.5 L ± 0.2 L	
		130/80-17		Top speed	110 km/h	
Drive Train	Clutch type	Wet multi-plate friction type		Performance	Slope climbing force	Maximum climbing angle is not less than 20 degrees
	Gear shift pattern	Manual 6 gear			Idle speed	1700± 100 rpm/min
	Drive Train	Clutch type			Max. torque	12.18 Nm/ 7500 r/min
Electrical	Battery capacity/type	12 V – 6 AH YUASA TT27SL			Max. power	11 Kw/ 9000 r/min
	Generator type	Alternating current permanent magnetic motor			Compression ratio	12.0 : 1
	Spark plug	NGK-CR8E			Pressure of cylinder	12,5-13,5 bar
	Spark plug clearance	0.7~0.8 mm		Braking system	Diameter of front brake disc	Φ 280 mm
	Ignition type	CDI			Diameter of rear brake disc	Φ 240 mm

WIRING DIAGRAM

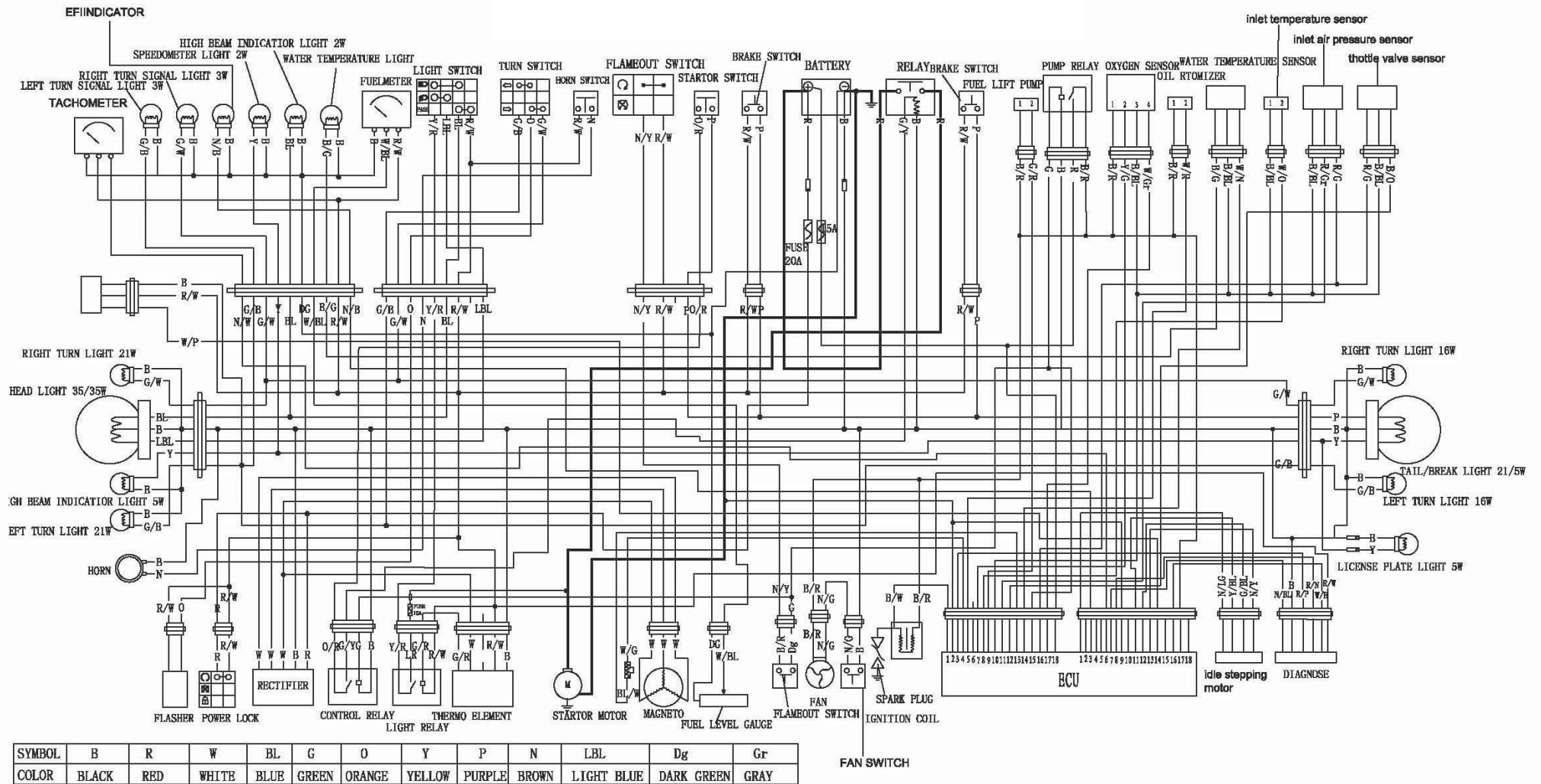

WARRANTY INFORMATION

Information on warranty claim

Please carefully read the instruction manual of your vehicle before operating it in order to make yourself familiar with its handling. We explicitly point out that the instruction, maintenance, and care instructions given in the operating manual have to be complied with in order to sustain your claim towards warranty. Only the strict compliance with customer specifications stated in the instruction manual ensures the prolonging of the natural life of your vehicle.

Starting with the date of the invoice a limited warranty of 24 months is granted regarding the accuracy of the vehicle in terms of material and manufacturing according to latest standards. The legal warranty regulations will not be restricted by this limited guarantee. Maintenance work has to be exclusively done by authorized workshops entitled by us. Warranty in generally is bound to the region of invoicing and can therefore only be carried out within

the country the vehicle was bought. Damages that can be traced back to inappropriate usage, manipulation, or neglecting of the maintenance/care/operating instructions will not be covered by warranty. Warranty can only be granted if occurring damages are immediately being reported to the seller or any other authorized workshop by the buyer. The warranty claim entitles the buyer to remedy deficiencies or to the reparation respectively the exchange of a damaged part in an authorized workshop after our approval. Compensation for remote or instantaneous damages cannot be granted. Vehicles in desolate condition will not be covered by warranty. Repair works carried out on warranty do not enlarge the guarantee period.

Only this document entitles you to call on warranty services. Therefore please make sure that you are delivered this fully filled in document by the seller and that he has registered your vehicle correctly in our system. Please also mind the following advices:

Body and panelling of the vehicle have to be kept free of dirt constantly. Do not use high pressure water blasters, strong jets of water, sharp and corrosive or other aggressive detergents which could harm surfaces and varnish permanently and foster corrosion. It is vital to use protecting cleansers.

Please consult one of our dealers for the right and appropriate products. Aluminium parts or other refined parts (chrome parts, anodized parts or other processed surfaces) have to be treated with appropriate maintenance products in order to prevent oxidation. Frame and metal parts are continuously to be treated with anticorrosive. A vehicle constantly parked outside has to be covered to avoid weathering and crack formations on seat and plastic parts.

Vehicles used off-road and for racing purposes are excluded from warranty.

Material which is to be used in the context of service and maintenance works are excluded from warranty as well as the following parts: incandescent bulbs, brake pads, clutch lining, filter elements, spark plugs, drive sprocket, wheel and axle., as well as the tires.

SERVICEPLAN

1000 km or 1. Month Stamp/ Signature
7000 km or 12. Month Stamp/ Signature
13000 km or 24. Month Stamp/ Signature
19000 km Stamp/ Signature
25000 km Stamp/ Signature

4000 km or 6. Month Stamp/ Signature
10000 km or 18. Month Stamp/ Signature
16000 km Stamp/ Signature
22000 km Stamp/ Signature
28000 km Stamp/ Signature

From 13000 km maintenance should place every 3000 km or annually. The warranty can be granted only when the vehicle has been serviced in accordance with this Service plan.

