



VTD-HOC4F/I
2.0MP HD-SDI Indoor WDR
Dome Cameras



VITEK

FEATURES:

- 1/2.9" Sony CMOS (IMX122LOJ)
- 2.0 MegaPixel With full 1080p/720p HD-SDI Output (SMPTE 292M)
- 3.7mm Fixed Iris lens Included
- Mechanical IR Cut Filter (True Day/Night)
- 16:9 Video format
- Advanced OSD Functions: WDR, 3D-DNR, Night Watch DSS Low Light Color Technology, ACE (Adaptive Color Enhancement), Motion Detection, Privacy, Digital Zoom, HLM, Flip, Mirror
- 100% Pure Digital Transmission of video data
- Up to 700' HD Transmission Range (Depending on cable characteristics and integrity)
- 12VDC Operation
- Available in Ivory or Black



MENU

SETUP MENU

EXPOSURE

MODE SENS_UP BRIGHTNESS LENS SHUTTER AGC FREQ RETURN

WHITE BAL

AWB CHROMA RETURN

IMAGE

SHARPNESS MIRROR FLIP FREEZE DZOOM PRIVACY SHADING HLM
ACE RETURN

WDR / BLC

OFF WDR BLC

DNR

OFF LOW MIDDLE HIGH

DAY&NIGHT

AUTO COLOR B&W EXTERN MDIR

MOTION

OFF SET

SERIAL

CAM ID ID DISPLAY BAUDRATE RETURN

SYSTEM

DOUT SCALE GAMMA SET DOUT FORMAT DEFECT DET FCM MODE
FACTORY SET RETURN

EXIT

SETTINGS

OSD controls are located inside the camera.

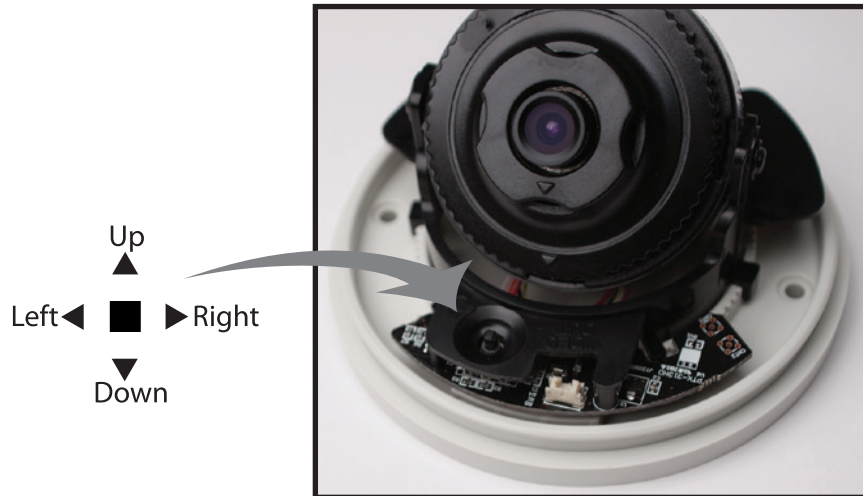

1. Depress the joystick to enter the setup menu
 - The Setup menu is now displayed on the monitor

MENU

Select any function you wish to change by pushing the joystick Up or Down

MENU

☀	EXPOSURE	↵
RG	WHITE BAL	↵
🖼	IMAGE	↵
📊	WDR / BLC	OFF
🛡	DNR	MIDDLE
🌙	DAY & NIGHT	AUTO ↵
📺	MOTION	OFF
RG	SERIAL	↵
☀	SYSTEM	↵
🚪	EXIT	

Modes can be changed by pushing the joystick Left or Right.

3. When finished programing camera select EXIT to save values.

SETUP

EXPOSURE, WHITE BAL, IMAGE, WDR / BLC, DNR, DAY&NIGHT, MOTTION, SERIAL, SYSTEM, EXIT control can be selected.

☀ EXPOSURE

- When the SETUP menu screen is displayed, select EXPOSURE by pushing the joystick up or down so that EXPOSURE is highlighted.

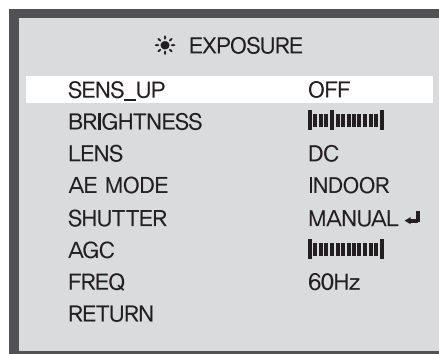
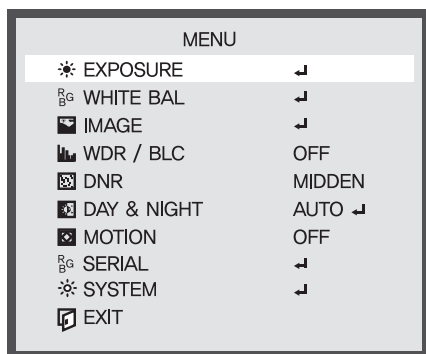

- SENS_UP : OFF / x2 / x3 / x4
 - When the SETUP menu screen is displayed, select EXPOSURE by pushing the joystick up or down so that EXPOSURE is highlighted.
 - When “SENS_UP” is on, shutter cannot be adjusted.
- BRIGHTNESS : Left Key (Decrease Level), Right Key (Increase Level)
- LENS : When using BUILT -IN LENS, the type of the lens can be set to either DC or Manual.
- AE MODE : You can select INDOOR / OUTDOOR / DEBLUR
- SHUTTER :
 - You can select either auto or manual shutter,
(1/30, 1/60, 1/120, 1/240, 1/500, 1/1000, 1/2000, 1/4000, 1/8000, 1/16000, 1/30000, 1/60000)
 - Shutter is set to “Manual” when DC Lens is selected
 - Shutter is set to “Auto” when Manual Lens is selected
- AGC (Auto Gain Control)
 - The higher the gain level, the brighter the screen - but the higher the noise.
- FREQ (AC Power Frequency Set)
 - You can select either 50Hz or 60Hz (PAL / NTSC)
- RETURN

WHITE BAL

- Use the White Balance function to adjust the screen color.
- When the SETUP menu screen is displayed, select 'White Bal.' by using the joystick up or down so that the arrow indicates White Bal.
- Select a desired mode using the joystick.

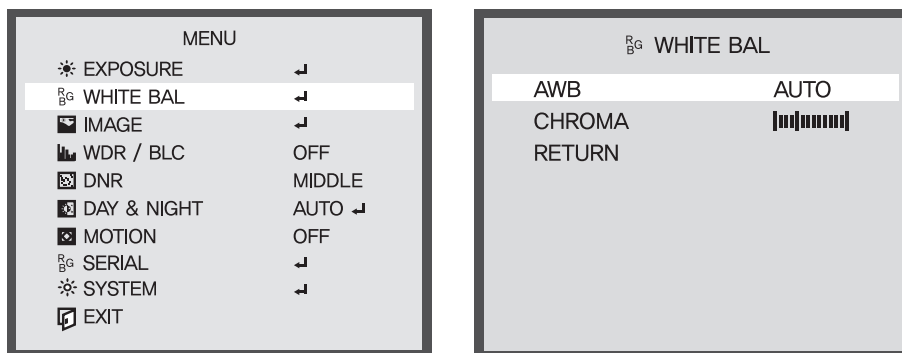

Select one of the following 2 modes, as appropriate for your purpose.

- AWB
 - AUTO : Default - This function continuously adjusts the white balance automatically to adapt to changes in lighting conditions.
 - AUTOEXT : When Halogen or other specialty lighting is used.
 - PUSHING : This function adjusts the white balance regardless of the subject conditions.
 - MANUAL : User preset
 - KELVIN : LOW / MIDDLE / HIGH
 - R-GAIN : Increase or Decrease Level.
 - B-GAIN : Increase or Decrease Level.
 - RETURN
- CHROMA : Increase or Decrease Level.
- RETURN

NOTE

- Under the following conditions the WHITE BALANCE function may not operate properly. In such cases, please select the AWB mode.
 - ① When the object's surroundings have a very high color temperature (eg, a clear sky and sunset)
 - ② When the object's surroundings are dark
 - ③ If the camera directly faces a fluorescent light or is installed in a place where there are considerable changes in illumination, the WHITE BALANCE function may become unstable.

IMAGE

MENU	
☼ EXPOSURE	↓
⚙ WHITE BAL	↓
📷 IMAGE	↓
🏠 WDR / BLC	OFF
🔍 DNR	MIDDLE
🌙 DAY & NIGHT	AUTO ↓
🏃 MOTION	OFF
⚙ SERIAL	↓
☼ SYSTEM	↓
🏠 EXIT	

IMAGE	
SHARPNESS	8
MIRROR	OFF
FLIP	OFF
FREEZE	OFF
DZOOM	0
PRIVACY	OFF
SHADING	OFF
HLM	OFF
ACE	OFF
RETURN	

IMAGE	
SHARPNESS	8
MIRROR	OFF
FLIP	OFF
FREEZE	OFF
DZOOM	0
PRIVACY	SET ↓
SHADING	OFF
HLM	OFF
ACE	OFF
RETURN	

PRIVACY	
ZONE NO	0
ZONE OP	ON
X - POS	12
Y - POS	2
X - SIZ	3
Y - SIZ	3
COLOR	CYN
TRANS	4
RETURN	

- SHARPNESS : Set from 0-10 (set to high and color will fade)
- MIRROR / FLIP : Turns Mirror / Flip On or Off.



OFF



MIRROR (ON)



FLIP (ON)

- FREEZE : The video can be stopped.
- DZOOM : Adjustable digital zoom from 0~127x.
- PRIVACY : This modes conceals the areas you do not wish to appear on the screen,

- OFF : Cancels the PRIVACY mode
- SET : Operates the PRIVACY mode
- ZONE NO : Adjust the size of masking area from 0 to 32
- ZONE OP : On or off masking
- X - POS : Adjust the horizontal position of masking area from 0 to 60
- Y - POS : Adjust the vertical position of masking area from 0 to 40
- X - SIZ : Adjust the width of masking area from 0 to 40
- Y - SIZ : Adjust the height of masking area from 0 to 40
- COLOR : WHT / YEL / CYN / GRN / MAG / RED / BLU / BLK
- TRANS : Adjust the transparency of masking area from 0 to 40
- RETURN

- SHADING : When using wide angle lens, you can compensate darkness of corner on the screen.
- HLM (High Light Mask)
HLM (High Light Mask) to prevent bright lights from washing out the picture i.e. headlights

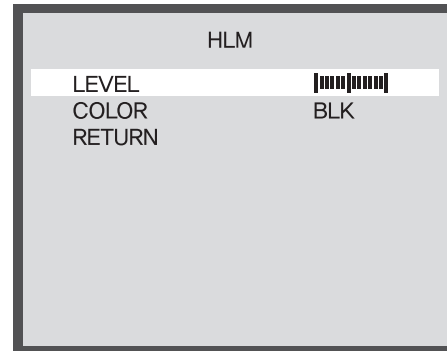
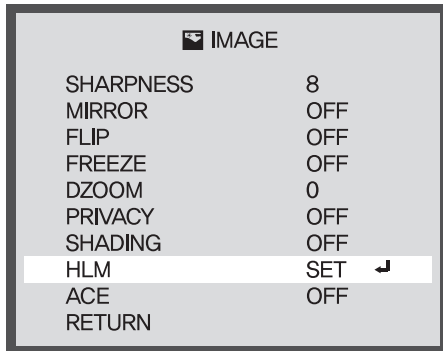

- LEVEL : Increase or decrease the level of HLM
- COLOR : WHT / YEL / CYN / GRN / MAG / RED / BLU / BLK
- RETURN

- ACE (Adaptive Color & Contrast Enhancement) : OFF / ON

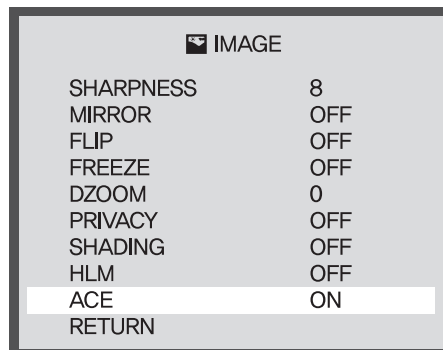

WDR / BLC

- OFF : function does not operate.

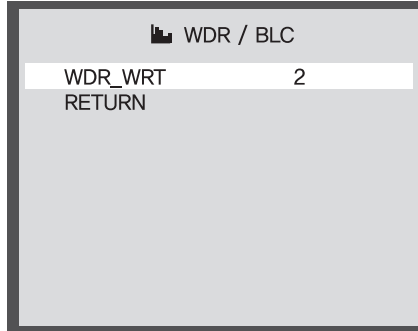
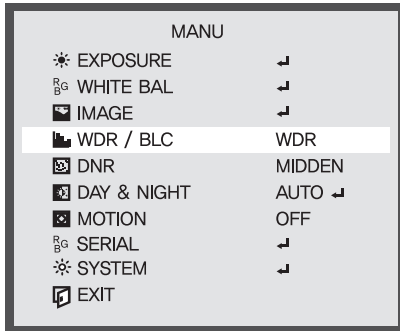

WDR (ON)



WDR (OFF)

- WDR (Wide Dynamic Range)

The Wide Dynamic Range feature improves the overall picture balance beyond the Backlight Compensation feature. It creates an optimal balance of brightness and color by combining images from a bright area (high shutter speed) and images from a dark area (low shutter speed).

- WDR_WGT : The available range of level is 0 ~ 4
- RETURN

- BLC (Backlight Compensation)

When there is a strong backlight behind the object, clear images of the background as well as the object can still be obtained by using the BLC function.

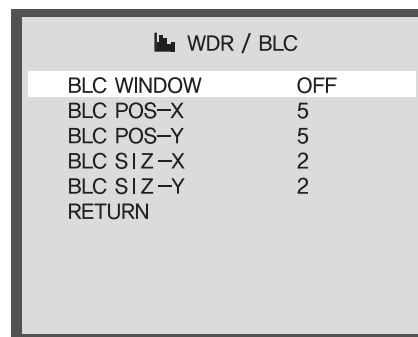
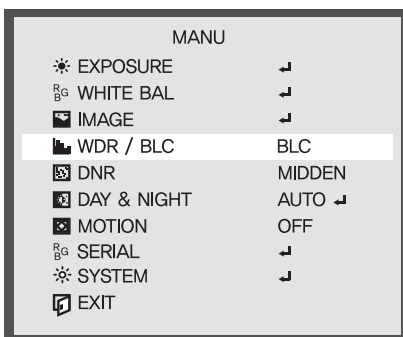

- BLC WINDOW : You can choice ON or OFF
- BLC POS-X : The available range of level is 0 ~ 20
- BLC POS-Y : The available range of level is 0 ~ 20
- BLC SIZ-X : The available range of level is 0 ~ 20
- BLC SIZ-Y : The available range of level is 0 ~ 20
- RETURN

DNR

DNR (Digital Noise Reduction)

- Reduces noise level in low light conditions.

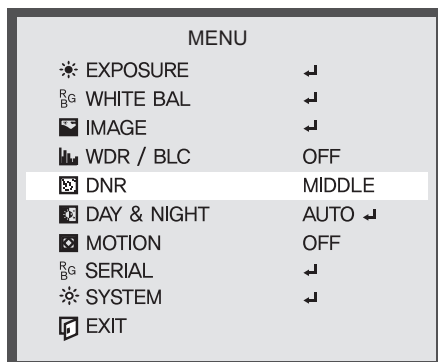

- OFF : DNR function does not operate.
- LOW / MIDDLE / HIGH : You can select 'LOW', 'MIDDLE' or 'HIGH' menu as DNR condition.

DAY&NIGHT

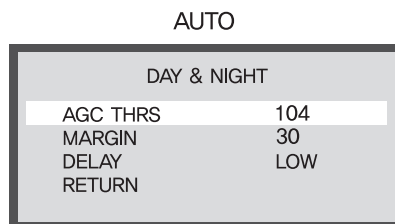
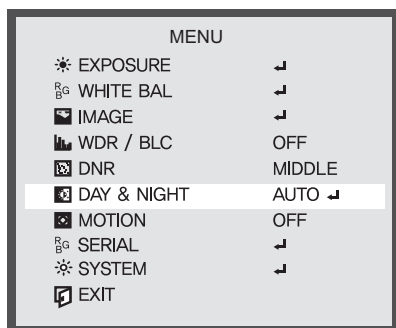

- AUTO : The camera will automatically show color image in high lux and black / white image in low lux.
- COLOR : This picture is always displayed in color.
- B&W : The picture is always displayed in black and white.
You can turn on or off the burst signal on B/W mode.

☒ MOTION

This product has a feature that allows you to observe movement of objects in 3 different areas on the screen, and the words 'MOTION' appear on the screen when movement is detected. you can monitor activity more efficient.

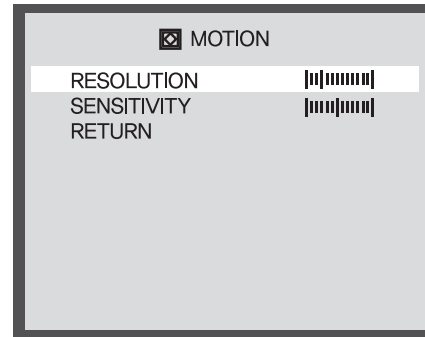
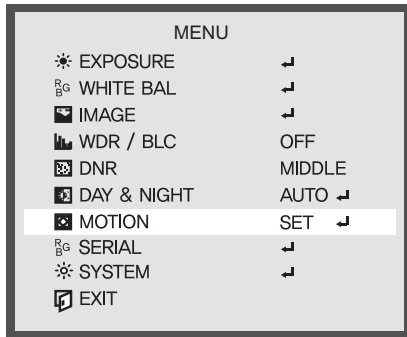

- OFF : MOTION mode is cancelled.
- SET : Any motion in the selected areas is observed.
 - Please select the area you wish to observe from the areas in SELECT mode.
 - Please select ON mode for the chosen area.
 - Please adjust the level of observation by using MOTION mode.
 - Please press the RETURN to save the changes and complete the setting.

Ⓜ SERIAL

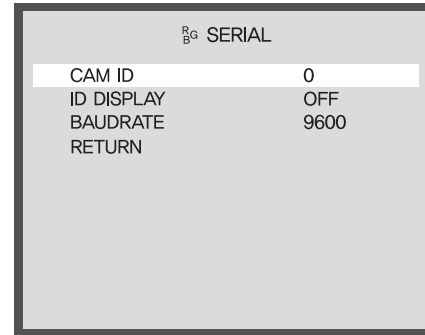
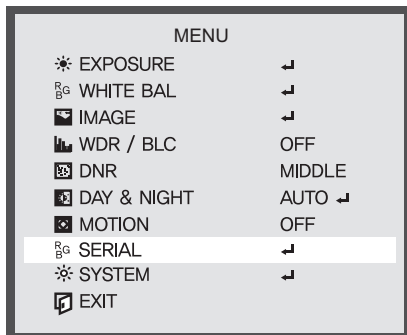

- CAM ID : You can select camera ID from 0 to 254 when using remote control.
- ID DISPLAY : You can select ID ON or OFF
- BAUDRATE : You can select 2400 / 4800 / 9600 / 19200/ 57600 / 115200 bps. Support "pel-D protocol"

☀ SYSTEM

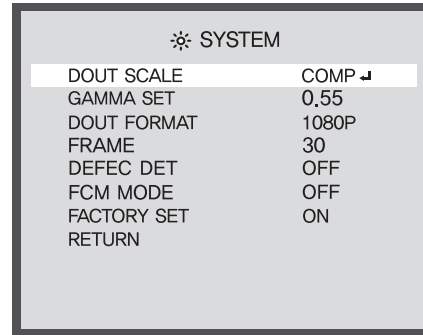
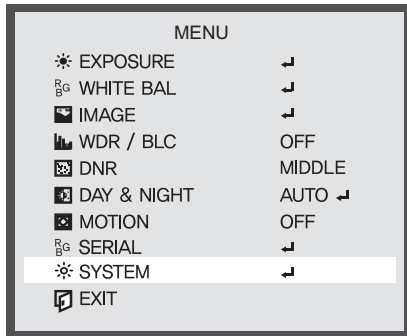

- DOUT SCALE : - FULL : Full Image out / COMP : Compress Image out
- The available image to level is 16 ~96
- GAMMA SET : You Can Select 0,40 / 0,45 / 0,50 / 0,55 / 0,60 / 0,65 / 0,70 / 0,75
- DOUT FORMAT : You can select (1080P / 720P)
- FRAME: Set output frame to 25 or 30 (PAL/NTSC). (Can be set to 50 or 60 at 720P mode)

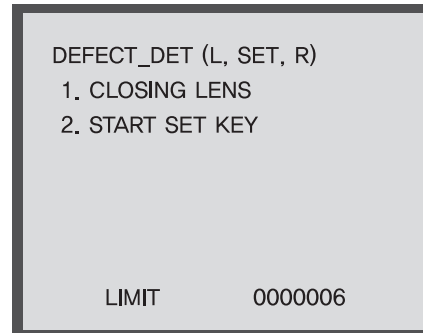
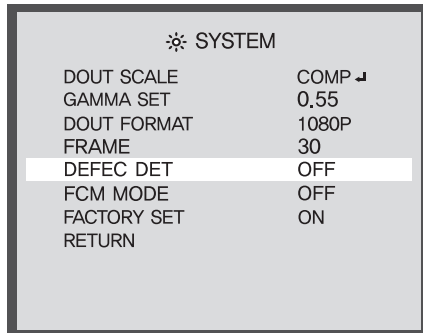

- DEFECT DET
 - OFF : To help Compensate for dead pixels
 - ON : Close the lens to block the light,
 - Adjust left & right buttons and press “SET” button to automatically start the mode.

☼ SYSTEM	
DOUT SCALE	COMP ▾
GAMMA SET	0.55
DOUT FORMAT	1080P
FRAME	30
DEFEC DET	OFF
FCM MODE	OFF
FACTORY SET	ON
RETURN	

FOCUS CONFIRM MODE

SET KEY : END
Adjust the Lever to Focus

- FCM MODE (In this mode the OSD might flicker)
 - OFF : FOCUS ADJ Mode is off.
 - ON : Zoom mode is activated automatically.
 - Adjust the focus while in zoom mode to better focus the camera
Press the "SET" button for desired focus.

- FACTORY SET : Factory Default
- RETURN

DIMENSIONS

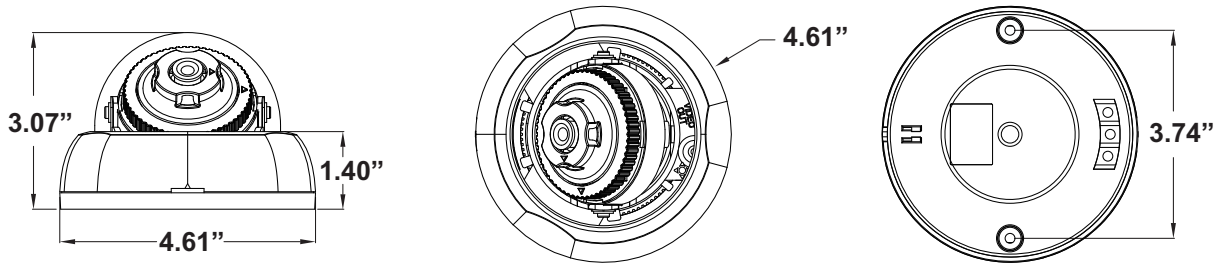

INSTALLATION

1. Opening

Use the coin to open the cover.

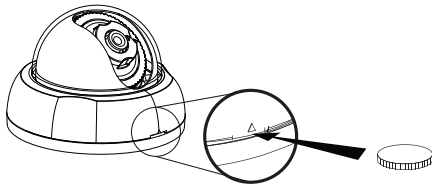

2. Place the camera in the desired location and install using the screws supplied.

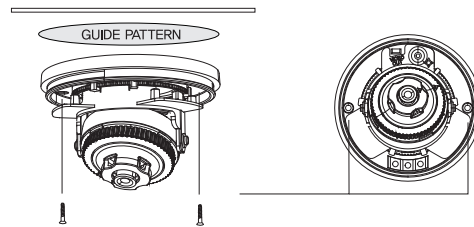

3. Connecting Cables

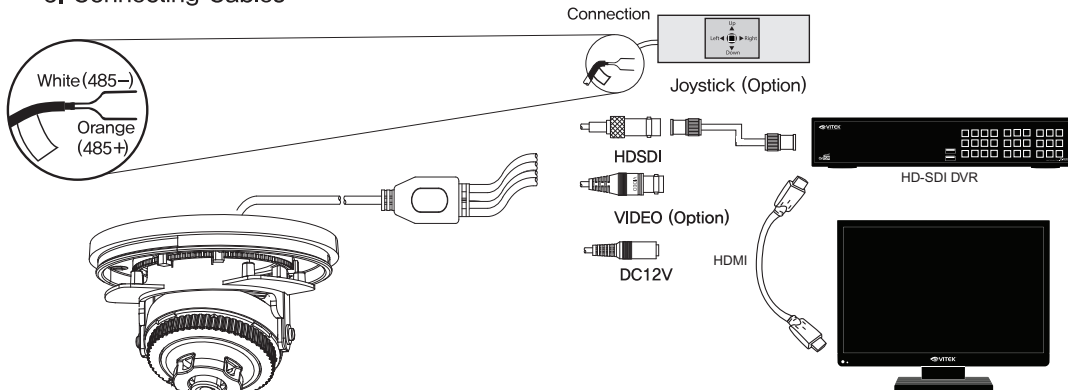

4. Pan / Tilt (3Axis) Controls

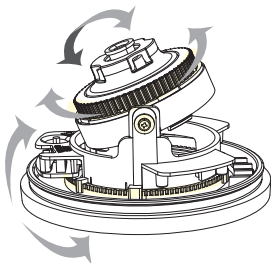

5. Closing the cover

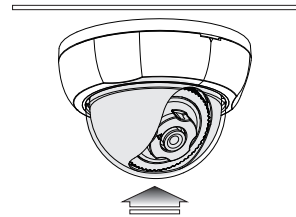

SPECIFICATIONS

Sensor	1/2.9" Sony CMOS (IMX122LQJ)
Resolution	2.0 MegaPixel (1080p / 720p)
S/N	More than 52 dB (AGC Off)
Video Output	1x HD-SDI (BNC) / 1x SD CVBS (BNC)
Lens	3.7mm Fixed
Minimum Illumination	1 Lux at F1.2 / 0.1 Lux (B/W)
Day/Night	Mechanical IR Cut Filter (True Day/Night)
Electronic shutter speed	Auto / Manual (1/30sec ~ 1/30,000sec)
White Balance	Auto / Auto EXT / Pushing / Manual
Brightness	Adjustable (0 ~ 20 Steps)
DSS (Sens-Up)	YES
DNR	3D-DNR
WDR	YES
OSD Language	English
Digital Zoom	0 ~ x127
Privacy	YES (32 Zones)
Motion Detection	YES
ACE (Adaptive Color Enhancement)	YES
Advanced OSD Functions	HLM, Flip, Freeze, Sharpness, Mirror
Communication	RS-485 (PELCO-D)
HD Transmission Range	Up to 700' (Depending on cable characteristics and integrity)
Operating Conditions	14°-122°F (-10°-50°C) < 80% RH
Input Voltage	12VDC
Dimensions	4.6" x 3.07" (Dia. x H)

LIMITED LIABILITY WARRANTY

VITEK products carry a three (3) year limited warranty. VITEK warrants to the purchaser that products manufactured by VITEK are free of any rightful claim of infringement or the like, and when used in the manner intended, will be free of defects in materials and workmanship for a period of three (3) years, or as otherwise stated above, from the date of purchase by the end user. This warranty is nontransferable and extends only to the original buyer or end user customer of a VITEK Authorized Reseller.

The product must have been used only for its intended purpose, and not been subjected to damage by misuse, willful or accidental damage, caused by excessive voltage or lightning.

The product must not have been tampered with in any way or the guarantee will be considered null and void.

This guarantee does not affect your statutory rights.

Contact your local VITEK Reseller should servicing become necessary.

VITEK makes no warranty or guarantee whatsoever with respect to products sold or purchased through unauthorized sales channels. Warranty support is available only if product is purchased through a VITEK Authorized Reseller.



28492 CONSTELLATION ROAD VALENCIA, CA 91355
WWW.VITEKCCTV.COM

Version 1.1
May 2013