

User Manual



VSS 15



SD 3



SD 4



SD 5



The digital system unit VSS 15

The fully digital system unit VSS 15 with integrated 15" subwoofer has been consequently developed to portable requirements. With a powerful bass base and very compact dimensions as well as the lightweight of 26 kg the VSS 15 is also the core and control center within the self-powered PA-systems SD 3, SD 4 and SD 5.

Inside work a digital 24 Bit signal processor and three powerful class D amplifiers with an unsophisticated, crystal-clear sound quality (without conversion losses due to full digital preamping). The analogue input signal is digitalized directly inside the input amplifier using an intelligent 24 Bit AD-converter and remains consequently digital to the class D amplifier's output. The audio-DSP enables an optimal processing and controlling of the audio signal through adjustable parameters like gain, digital cross-over, subsonic filter, parametric EQs, peak/RMS-limiter and delays. It serves also for a flexible signal routing of the loudspeaker outputs (e.g. for top units / monitors / subwoofer).

Factory presets and user presets can be choosen, loaded and adjusted through a navigation pad with a clear controlling scheme.

The integrated 15" subwoofer provides a low-frequent radiation starting from 40 Hz to 160 Hz. The special tunnel geometry enables a high sound pressure with extra low power compression and a low flow noise.

The high-quality scratch- and impact-resistant black polyurethane coating offers optimal road suitability. An additional protection of the loudspeaker offers the comb-grid with black acoustic foam and the special impregnation of the loudspeaker membrane against moisture impacts.

The delivery status

When you power up the VSS 15 for the very first time the following default parameters in the main menu are pre-set:

- preset 1 „VERSIO SD 3“ is loaded
- Sig. LED threshold is adjusted to -50 dB
- User LED threshold is adjusted to 0 dB (0 dB = deactivated)
- output levels are shown on the LCD display
- inputs switched to analogue
- a password is not entered

The connection panel

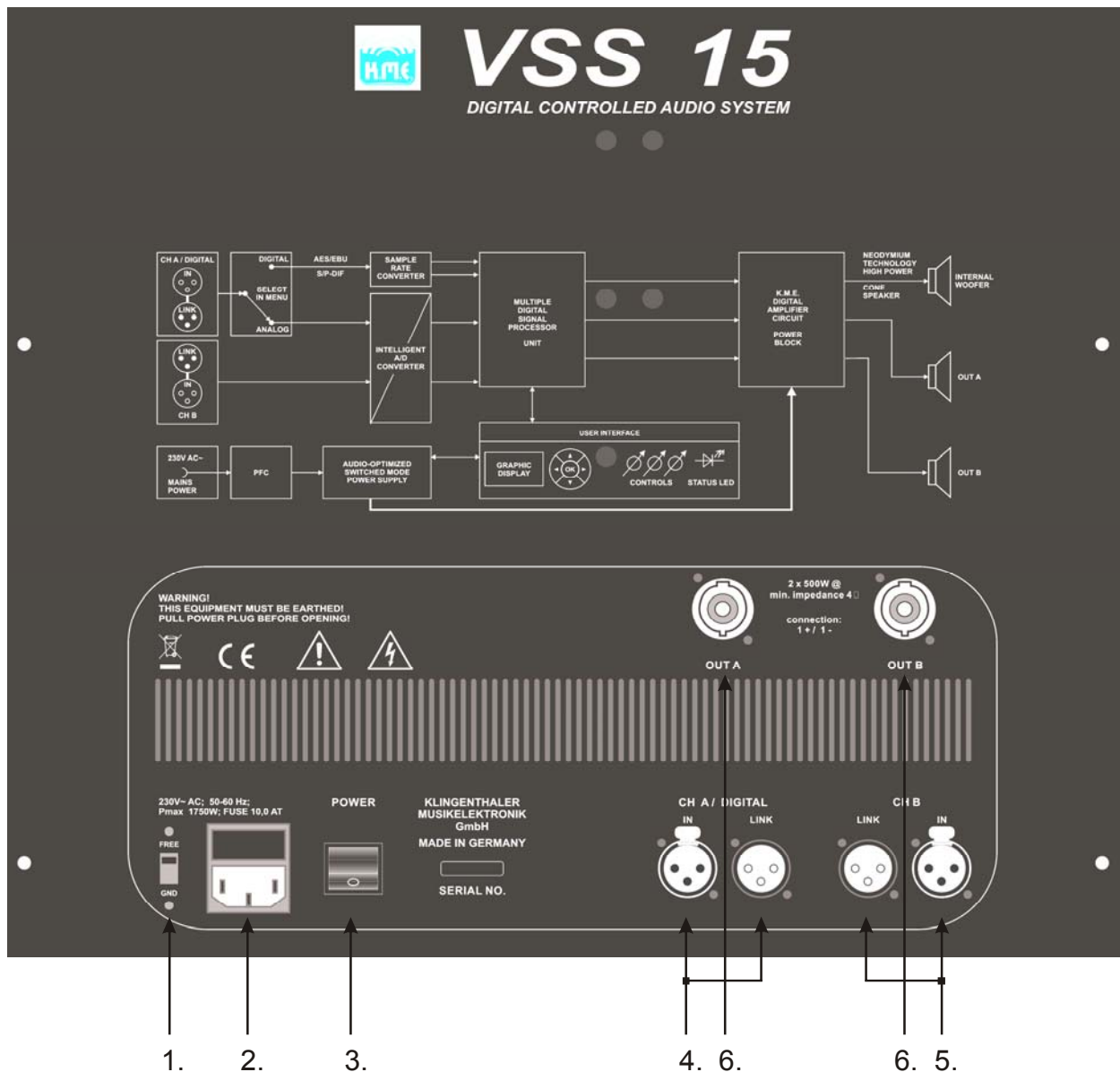

Power

1. GROUND/FREE switch (disconnects the ground of the input channels from chassis to avoid ground loops)
2. Mains socket with integrated fuse holder (replace fuse only by type 10A slow blowing fuse 5x20 mm), **Attention:** use only the correct mains voltage 230 V AC (conforming to standard IEC 60320-C14).
3. Power switch, **Attention:** please turn down all volume controls before switching on the VSS 15 to avoid an undesirable sound reproduction.

Connections

4. Line in & link out - XLR balanced, analogue/digital switchable (see navigation structure); link out is only active when the VSS 15 is powered on
5. Line in & link out - XLR balanced, always analogue; link out is only active when the VSS 15 is powered on
6. Speaker output - 2x Speakon NL 4 (2x 500 W @ 4 Ohm (min. impedance), depending on preset), **Attention:** Please mind nominal load and impedance of the passive loudspeaker(s) you connect.

The control panel

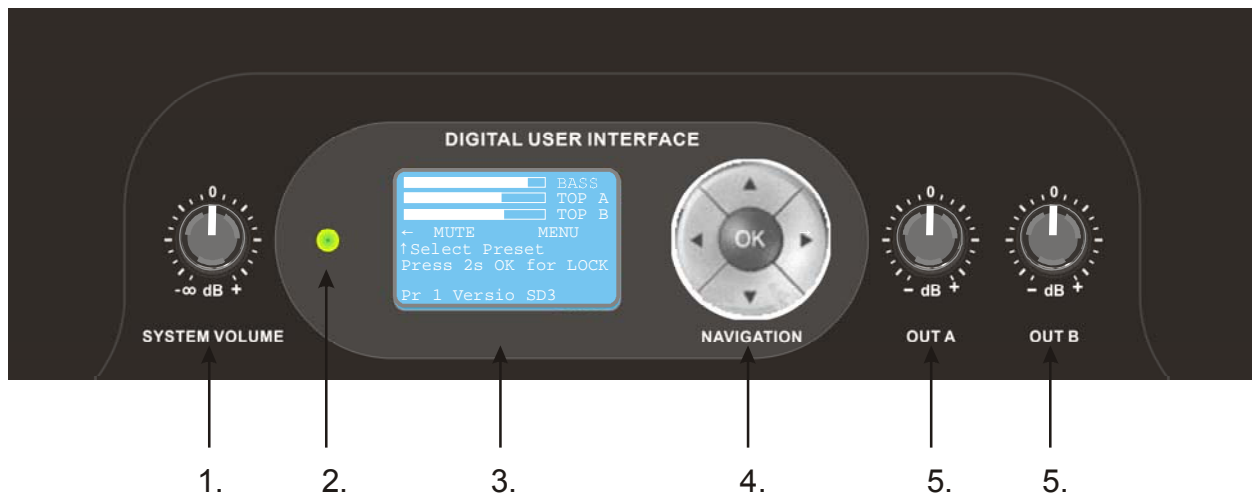

Operation

1. System Volume (the “Level Control Mode” is pre-set in factory presets, see page 15) and volume control for the internal loudspeaker (adjustable from $-\infty$ to +6 dB)
2. Multicolour LED signalling different parameters:
 - LED does not light up - there is no input signal
 - LED lights up green - there is an input signal
 - LED lights up blue - the adjusted user threshold value is exceeded
 - LED lights up yellow - max. input level, the limiter is working
 - LED lights up red - there is a malfunction, you must power cycle the VSS 15
3. The LCD display is used as operation mode display of the VSS 15. The arrows in the LCD display show the directions to navigate through the submenus (see navigation structure). All software parameters must be set on the unit itself. Press the ‘OK’ button to select a parameter if you are asked by the unit.
4. Navigation pad - The navigation pad is to be used for accessing and changing parameters on the display of the hardware unit. Press the OK button if you are asked by the software (see navigation structure).
5. Volume control for each output channel (adjustable from $-\infty$ to +6 dB)

General view about presets

Currently the VSS 15 includes eight factory presets and four useful adjusted user presets. When switching on for the first time preset 1 “VERSIO SD 3” is loaded (a factory preset). You can load factory presets and change it can be made you will find it on page 16 in this manual. The menu item „Userpresets“ appears only from preset no. 9 to 12, where you can set and adjust the parameters like limiter, EQs, delays for the outputs.

The names of the presets (listed below) refer to the menu navigation of the device.

Factory presets - are not adjustable and erasable

Preset 1: VERSIO SD3

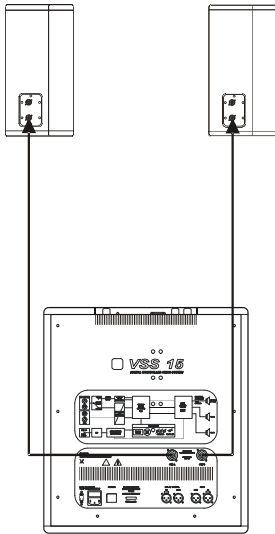

1x VSS 15 + 2x VL 8:
analogue audio signal to input A + B
or digital audio signal to input A

Preset 2: VERSIO SD4

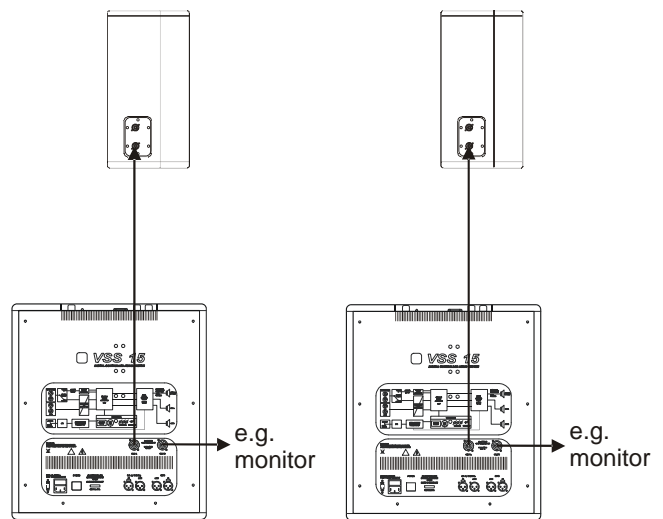

2x VSS 15 + 2x VL 12 + two independently adjustable analogue XLR-inputs (full-range) as well as two speaker outputs (Speakon NL 4): analogue or digital audio signal respectively to input A, input B can respectively be used as an auxiliary

Preset 3: VERSIO SD5

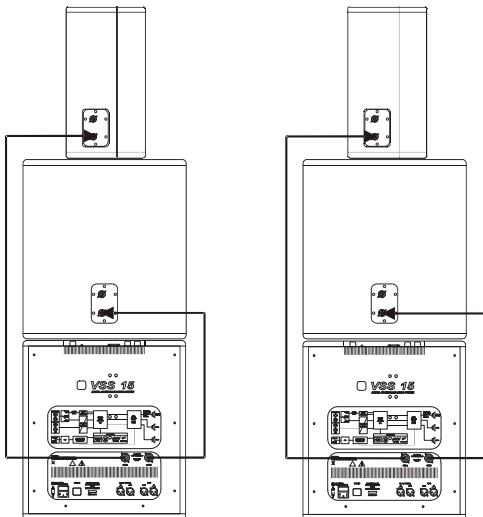

Preset 4: SD3 extended

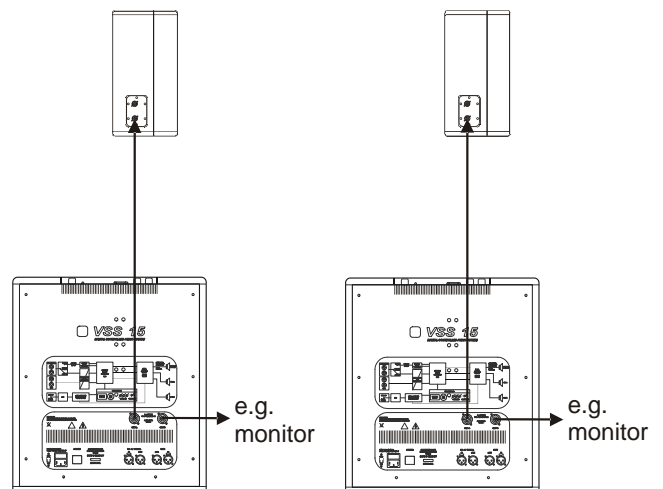

2x VSS 15 + 2x VB 15 + 2x VL 12:
 out A = each with a top unit / out B = each
 with a bass, analogue or digital audio signal
 respectively to input A ; input B is not used

Preset 5: SD5 extended

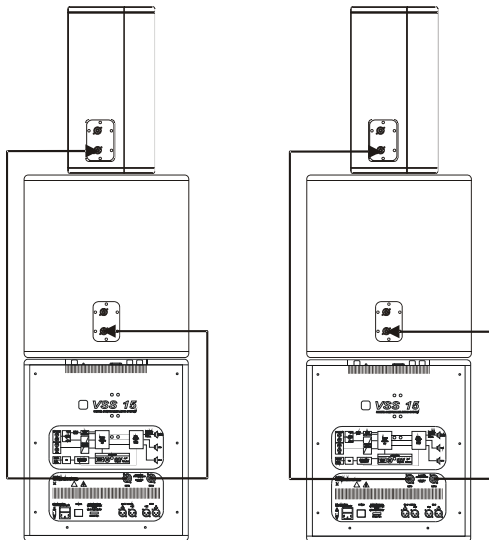

2x VSS 15 + 2x VB 15 + 2x VL 15:
 out A = each with a top unit / out B = each
 with a bass, analogue or digital audio signal
 respectively to input A ; input B is not used

Preset 7: TOPS ONLY

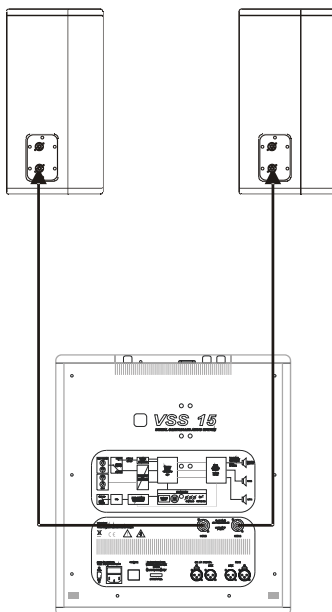

2x top units full-range (bass is muted):
 analogue audio signal to input A + B
 or digital audio signal to input A

2x VSS 15 + 2x VL 8 + two independently
 adjustable analogue XLR-inputs (full-range)
 as well as two speaker outputs (Speakon NL 4):
 analogue or digital audio signal respectively
 to input A, input B can respectively be used as
 an auxiliary

Preset 6: SINGLE BASS

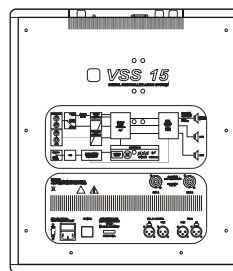

1x VSS 15 (speaker outputs are inactive):
 analogue audio signal to input A + B
 or digital audio signal to input A

Preset 8: BASS ARRAY

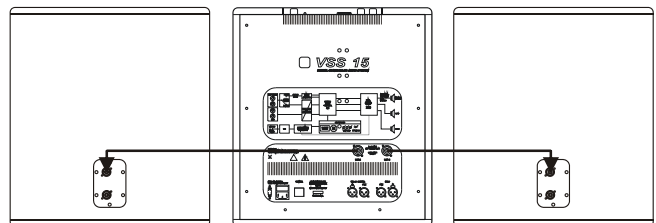

1x VSS 15 + 2x VB 15:
 analogue audio signal to input A + B
 or digital audio signal to input A

User presets - are adjustable and programmable

These user presets are always saved in the background. So you can set your own presets or adjust the presets 9 -12 and save in the respective presets. Your presets you can delete separately (by the command “Reset Preset”, see menu navigation) to restore the initial state resp. to overwrite it. When you will use those presets like shown the graphics, please make sure that the presets are not changed! Otherwise choose the command “Reset Preset”.

Preset 9: USER SD3

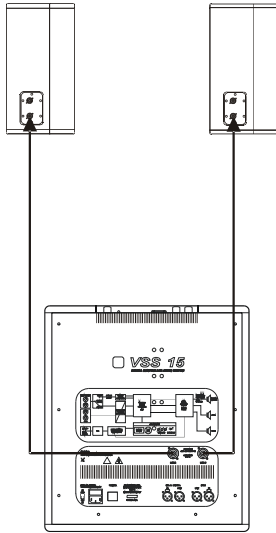

1x VSS 15 + 2x VL 8
you can set-up your audio inputs & speaker outputs

Preset 10: USER PA+DLY

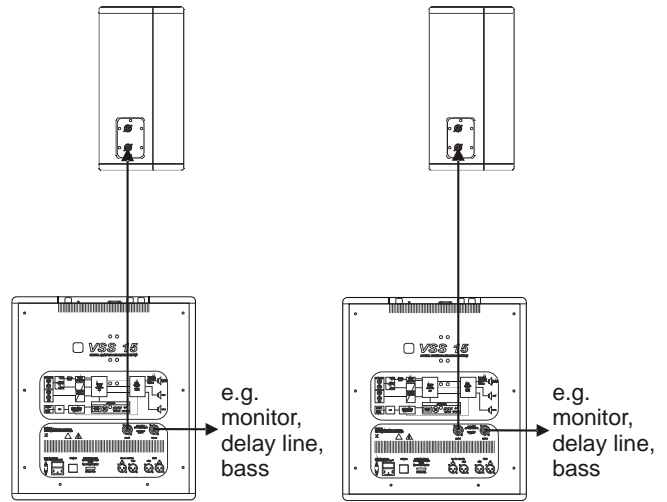

2x VSS 15 + 2x VL 12
you can set-up your audio inputs & speaker outputs

Preset 11: USER BMS 1

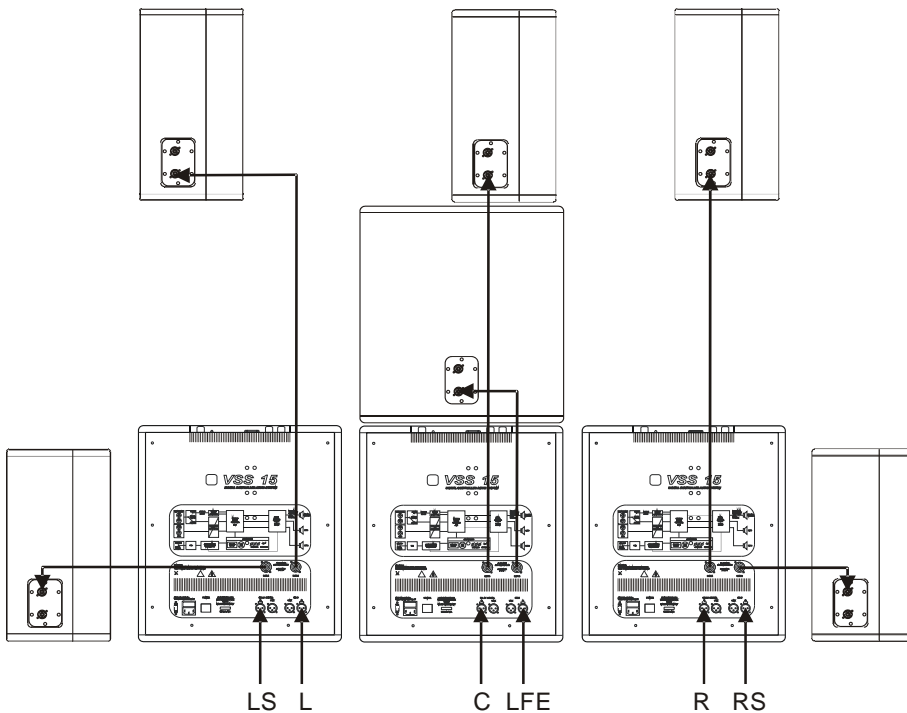

3x VSS 15 + 1x VB 15 + 5x top units (audio inputs & speaker outputs are free configurable).
 Bassmanagement system for smaller surround systems (5.1). The VSS 15 for the center channel and LFE-channel (low frequency enhancement) is used with this preset. You can connect an additional bass VB 15 on the speaker output B. The VSS 15 for the L/LS and R/RS are used with the presets no. 9.

Preset 12: USER BMS 2

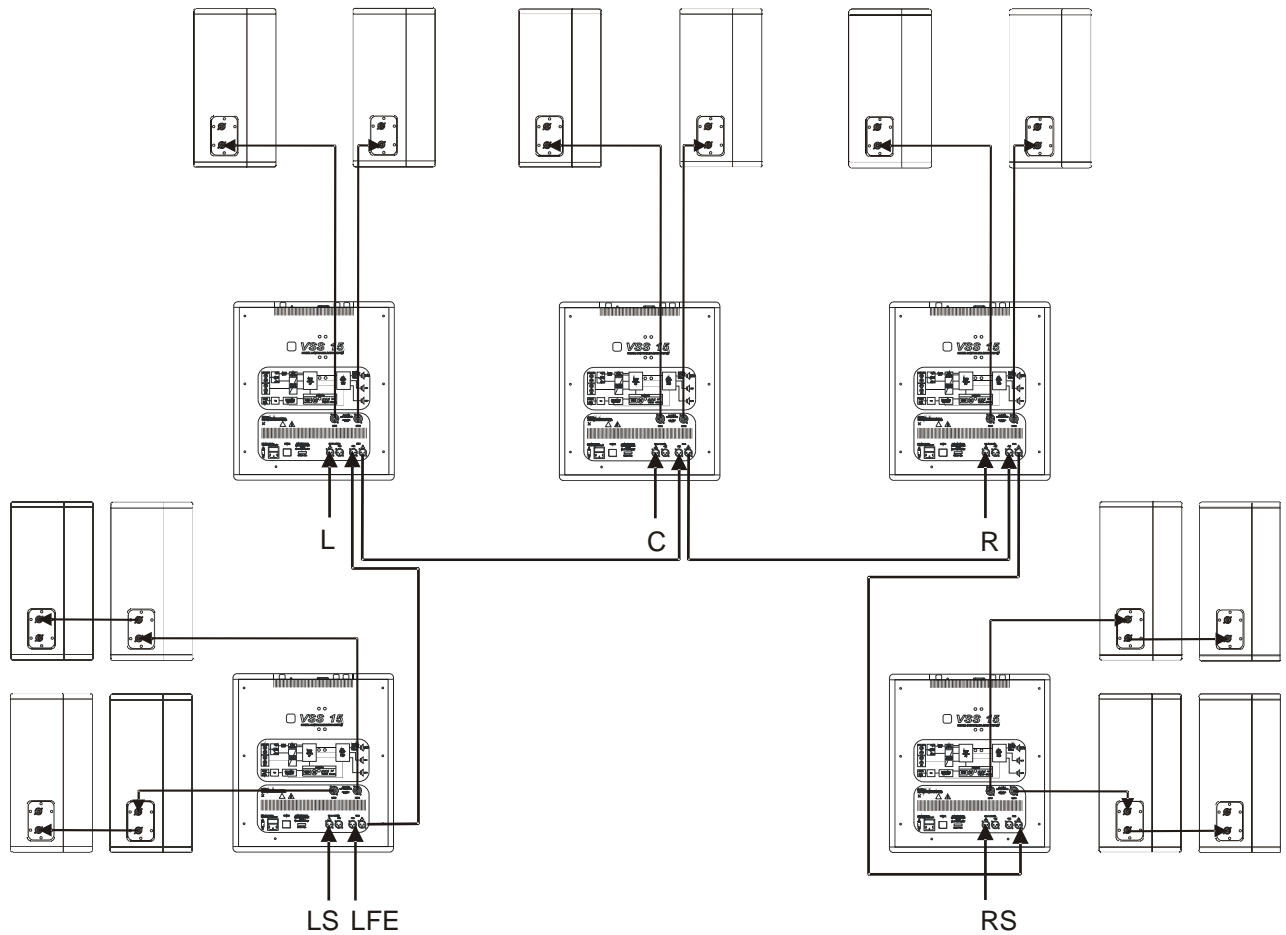

5 x VSS 15 + max. 14x top units (audio inputs & speaker outputs are free configurable).
 Bassmanagement system for larger surround systems (5.1, extendable) using several loudspeakers for all channels, for example like cinemas and multimedia installations. All VSS 15 are used with this preset.

The navigation structure (menu navigation)

by means of the information on the LCD display

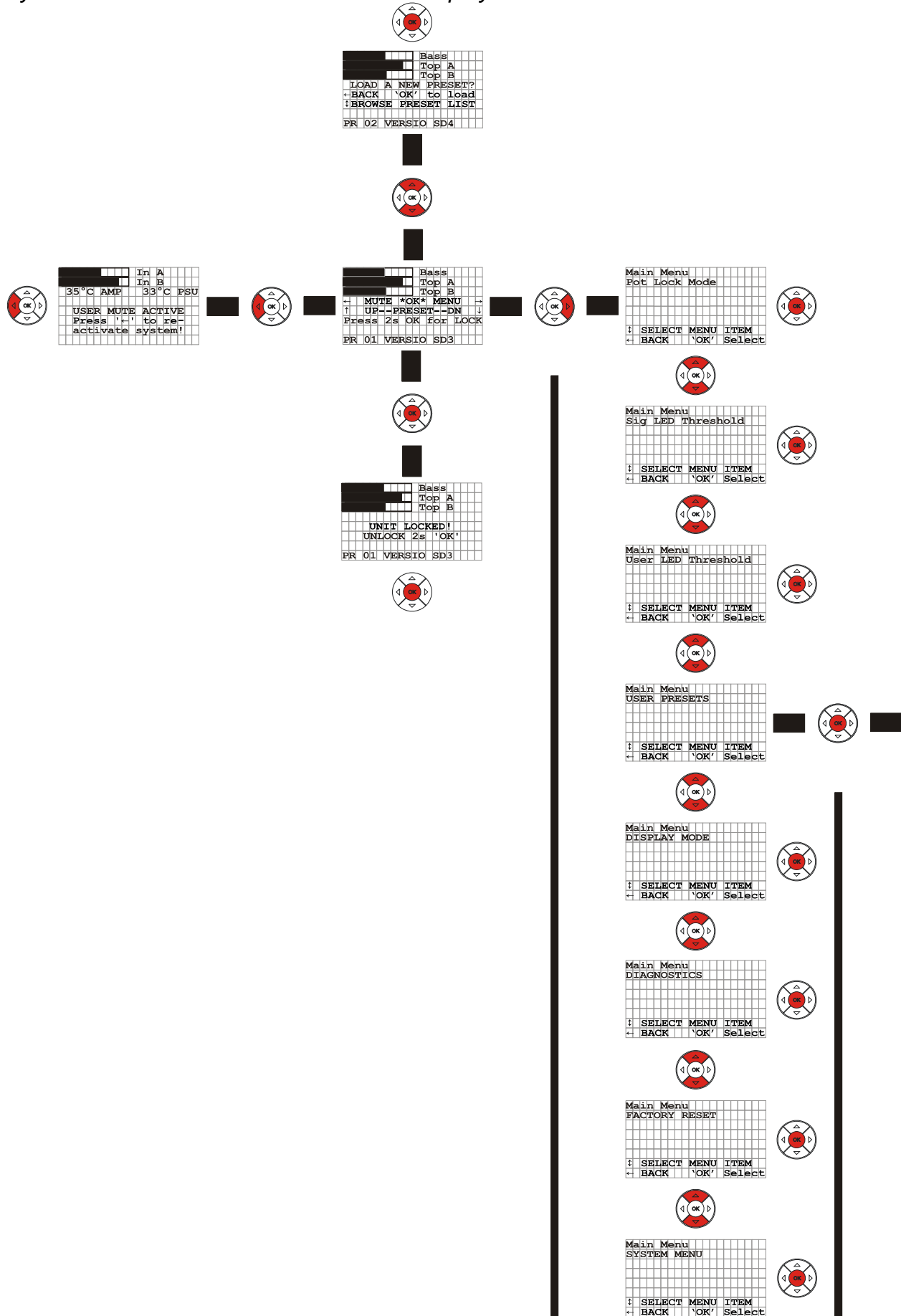

```

Main Menu
USER PRESETS
NAMES
↓ SELECT MENU ITEM
← BACK 'OK' Select

```



```

Main Menu
USER PRESETS
BASS
↓ SELECT MENU ITEM
← BACK 'OK' Select

```



```

Main Menu
USER PRESETS
BASS
ROUTING
↓ SELECT MENU ITEM
← BACK 'OK' Select

```



```

Main Menu
USER PRESETS
Out A
↓ SELECT MENU ITEM
← BACK 'OK' Select

```



```

Main Menu
USER PRESETS
BASS
DELAY
↓ SELECT MENU ITEM
← BACK 'OK' Select

```



```

Main Menu
USER PRESETS
Out B
↓ SELECT MENU ITEM
← BACK 'OK' Select

```



```

Main Menu
USER PRESETS
BASS
CROSSOVER LOW CUT
↓ SELECT MENU ITEM
← BACK 'OK' Select

```



```

Main Menu
USER PRESETS
LEVEL CONTROL MODE
↓ SELECT MENU ITEM
← BACK 'OK' Select

```



```

Main Menu
USER PRESETS
BASS
CROSSOVER HIGH CUT
↓ SELECT MENU ITEM
← BACK 'OK' Select

```



```

Main Menu
USER PRESETS
RESET PRESET
↓ SELECT MENU ITEM
← BACK 'OK' Select

```



```

Main Menu
USER PRESETS
BASS
EQUALIZER 1
↓ SELECT MENU ITEM
← BACK 'OK' Select

```



```

Main Menu
USER PRESETS
BASS
EQUALIZER 2
↓ SELECT MENU ITEM
← BACK 'OK' Select

```



```

Main Menu
USER PRESETS
BASS
Output Level
↓ SELECT MENU ITEM
← BACK 'OK' Select

```



```

Main Menu
USER PRESETS
BASS
Limiter
↓ SELECT MENU ITEM
← BACK 'OK' Select

```



by means of the information of the menu list

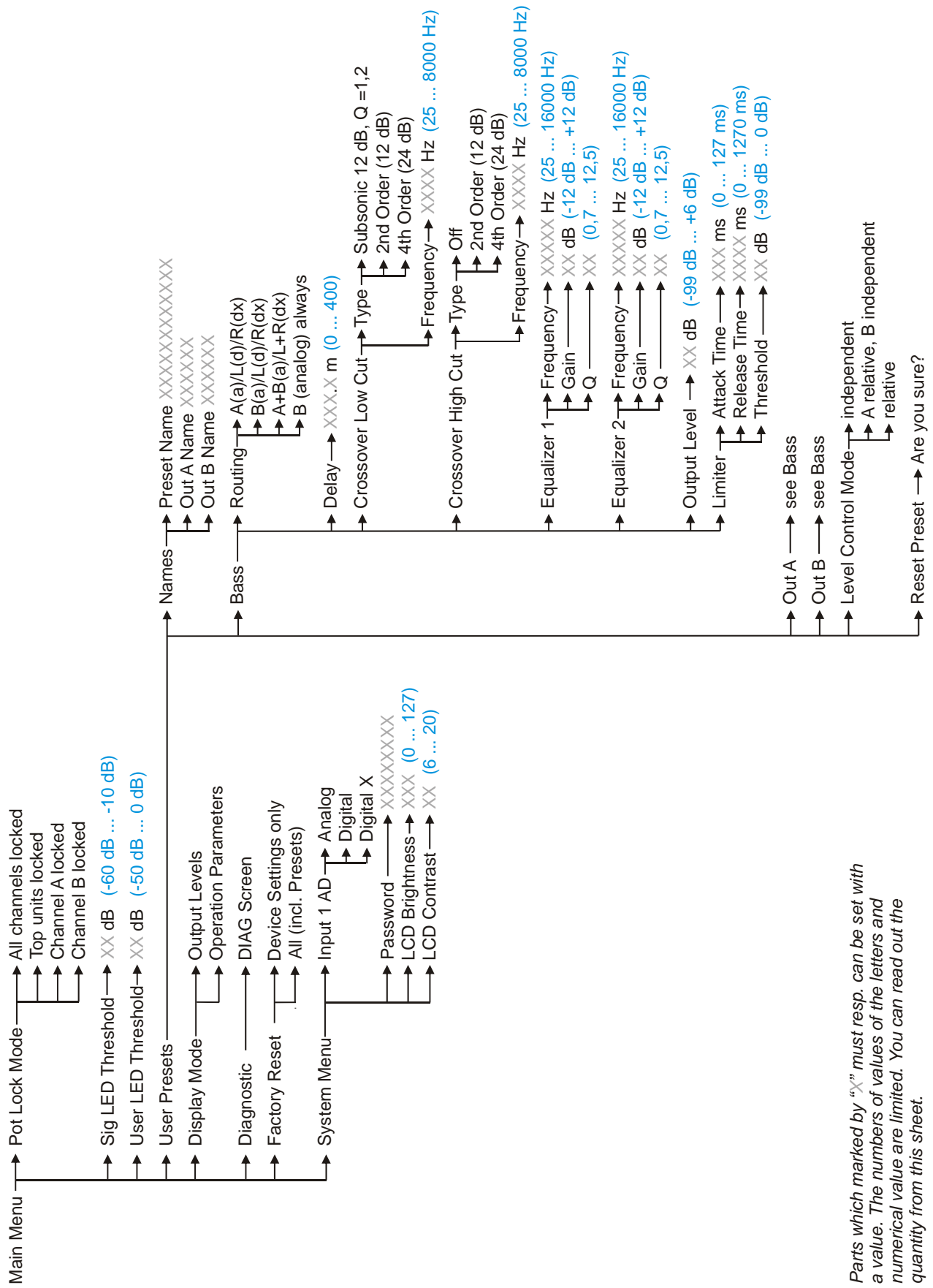

Parts which marked by "X" must resp. can be set with a value. The numbers of values of the letters and numerical value are limited. You can read out the quantity from this sheet.

Operation

All these components must be set directly on the hardware device.

The adjustable parameters in the submenu “user presets” for Bass / Out A / Out B are identical.

The names of the menu points refer to the user navigation on the device.

Main Menu

- **Pot Lock Mode** *[to be activated by using “lock function”, see page 19]*

All Channels locked *[all volume pots locked]*

Tops only *[just lock the volume pots for Out A and Out B]*

Channel A *[just lock volume pot for out A]*

Channel B *[just lock volume pot for out B]*

In this menu you can set four different „lock - functions“ for the three volume pots of the VSS 15.

- **Sig LED Threshold**

Here you set the Threshold value where the LED starts to light green when the set value is reached by the audio signal.

- **User LED Threshold**

Here you set the Threshold value where the LED starts to light blue when the set value is reached by the audio signal.

- **Display Mode**

Output Levels *[output level display]*

Operation Parameters *[input level display and operation display]*

You can chose between two layouts of the LCD graphic display. The first one shows the output levels and the other one gives an overview about input levels and temperature of the amplifier and PSU (PowerSupplyUnit). If the unit is muted, the operation parameter screen is displayed automatically.

- **Diagnostics**

At the moment in this menu you can read out the currently software version.

- **Factory Reset**

Device Settings only *[Restore all adjustable parameters in the main menu]*

All (incl.Presets) *[Reset all changes made, incl. all user presets]*

To reset the unit to the programmed initial state there are two “levels”, just to restore only the parameters adjustable in the main menu or all menu items (incl. all user presets). After resetting all changed settings are turned to the programmed initial state!

- **System Menu**

Input 1 AD (see page 17)

Analog *[switch input of channel A to analogue]*

Digital *[switch input of channel A to digital]*

Digital X *[switch input of channel A to digital X]*

In this menu item you switch the input of channel A to analogue or digital or digital X. Digital X causes a swaping of the left resp. right “audio-channel” of the digital signal on the input of VSS 15, e.g. for the digital controlling of SD 4 and SD 5 (for the left and right side).

Password (see page 18)

In this menu item you can enter an 8-digit password. If you have entered a password and activate the “lock function” you must enter the password again to unlock the unit.

LCD Brightness *[adjust brightness of the LCD graphic display]*

LCD Contrast *[adjust contrast of the LCD graphic display]*

- **User Presets** *[appears only from preset no. 9 to 12]*

Names

Preset Name *[enter preset name, max. 12 digits]*

Out A Name *[enter name of output A, max. 6 digits]*

Out B Name *[enter name of output A, max. 6 digits]*

Bass

Routing *[routing of the input channels]*

A(a)/L(d)/R(dx)

B(a)/R(d)/L(dx)

A+B(a)/L+R(dx)

B (analog) always

The routing of channel A and B offers four possibilities:

1. analogue (left) or digital (left) or digital crossed (right)
2. analogue (right) or digital (right) or digital crossed (left)
3. analogue (left + right) or digital (left + right)
4. input B always analogue

Delay *[adjust delay, in 10 cm steps]*

Crossover Low Cut (high pass) *[crossover function]*

Type (Subsonic-Filter 12 dB Q=1,2 or 12 dB/Oktave or 24 dB/Oktave)

Frequency

This digital filter (crossover) limits the frequency range above the adjustable crossover frequency with a selectable slope of 12db/octave or 24 dB/octave. You can not deactivate this digital filter. When you need a full-range audio signal on the outputs A + B you should set the frequency to 25 Hz and choose a type of the low cut filter.

Crossover High Cut (low-pass) *[crossover function]*

Type (Off or 12 dB/Oktave or 24 dB/Oktave)

Frequency

This digital filter (crossover) limits the frequency range below the adjustable crossover frequency with a selectable slope of 12db/octave or 24 dB/octave. This filter can be deactivated (Off).

Equalizer 1 *[adjust equalizer]*

Frequency

Gain

Q (bandwidth)

With this digital filter (parametr. EQ) you can affect the frequency range by making adjustments of filter frequency (center frequency), the Gain (boost resp. cut) and the Q-factor (bandwidth). If you adjust the sensitivity (Gain) to 0 dB you deactivate this filter.

Equalizer 2 *[adjust equalizer]*

Frequency

Gain

Q (bandwidth)

See adjustable parameters Equalizer 1.

Output Level *[adjust output level, it is independent to the adjustment of the volume pots]*

Limiter *[adjust limiter]*

Attack Time

Release Time

Threshold

This dynamic processor is working when the audio signal exceeds the entered threshold-value. The two time constants attack and release time draw the speed of the gain regulation mechanism and are dependent to the program material.

Out A (see adjustable parameter bass)

Out B (see adjustable parameter bass)

Level Control Mode [*adjustment resp. control of output level*]

independent

A relative, B independent

relative

In level control mode you define the pre-settings (dependence) of the single potentiometers (volume controls) in relation to the output level of the different channels (Bass / Out A / Out B). Consequently you have three possibilities:

1. All volume controls are independently adjustable from each other. (independent).
2. The volume control for Out A depends on system volume control (master), Out A is adjustable from $-\infty$ to +6 dB; the adjustment of Out B is independent. (A relative, B indep.)
3. The volume controls for Out A and Out B are dependent on the system volume control (master), they are adjustable from $-\infty$ to +6 dB. (relative)

Reset Preset

Are you sure?

Here you can reset the preset to the programmed initial state, that means you re-activate the factory-made user preset on this memory cell and delete your preset. If you want to change one or more menu items in a user preset, choose this topic and overwrite it with a new value and press the OK button. Hence the new value is saved in the preset without entering all set parameters again.

Choose your factory preset - play!

In this part of the user manual you will find a structured digest about the procedure for the necessary settings with the main menu and its functions. If you pay attention to that a riskless use of the VSS 15 is ensured.

After building up the your PA system SD 3 / SD 4 /SD 5 (see page 23) you must choose the valid preset(s) for your current setup in the system menu in the VSS 15.

Powering up

Switch on the VSS 15 when all volume pots are are turned fully anti-clockwise / left stop and all connected components are switched on and muted previously to avoid an unwanted sound reproduction.

Because the VSS 15 can be in „lock-function“ for rental purposes that means the VSS 15 may not (depending on adjustment) react on changes on the control panel and this can cause an immediate reproduction when switching it on. Therefore it is necessary to mute all connected devices previously.

After switching on the VSS 15 all volume pots should be turned to 0 dB (center click) with deactivated „lock-function“ to keep a defined signal level and an optimal controlling (this demand is just a recommendation)

Note! During power on for the very first time Preset 1 „VERSIO SD 3“ is loaded! More information about the initial state you can find on page 3.

Choosing presets

To control the respective system optimally the valid preset has to be load. You must select it and load your latest PA-setup as preset on the control panel of the VSS 15. Follow the instructions (e.g. select SD 5)!

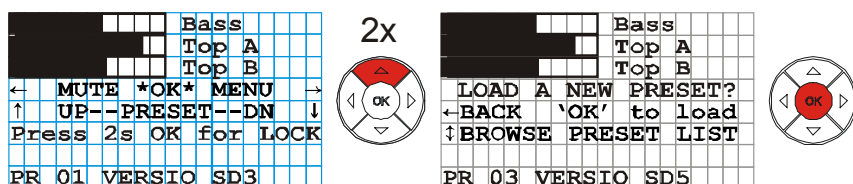

After power on the VSS 15 for the very first time the left graphic appears on the LCD display. You have to press the marked arrow-key of the navigation pad two times to select preset 3 „VERSIO SD5“ and confirm with the OK-key. In this case this procedure has to be done once again on the second VSS 15 of the SD5.

If you control your PA system with an analogue audio signal, **you can start now!**

Switching input of channel A between analog / digital / digital X

If you want to control your PA system with a digital signal you have to switch the input of channel A to „digital“ resp. „digital X“ (see page 13). In the programmed initial state all inputs are switched to „analogue“.

1.

				Bass				
				Top A				
				Top B				
←	MUTE	*OK*	MENU	→				
↑	UP	--PRESET	--DN	↓				
Press 2s OK for LOCK								
PR 01 VERSIO SD3								



2.

Main Menu			
Pot Lock Mode			
↓ SELECT MENU ITEM			
← BACK 'OK' Select			



3.

Main Menu			
Sig LED Threshold			
↓ SELECT MENU ITEM			
← BACK 'OK' Select			



4.

Main Menu			
User LED Threshold			
↓ SELECT MENU ITEM			
← BACK 'OK' Select			



5.

Main Menu			
DISPLAY MODE			
↓ SELECT MENU ITEM			
← BACK 'OK' Select			



6.

Main Menu			
DIAGNOSTICS			
↓ SELECT MENU ITEM			
← BACK 'OK' Select			



7.

Main Menu			
FACTORY RESET			
↓ SELECT MENU ITEM			
← BACK 'OK' Select			



8.

Main Menu			
SYSTEM MENU			
↓ SELECT MENU ITEM			
← BACK 'OK' Select			



9.

Main Menu			
SYSTEM MENU			
Input 1 A/D			
↓ SELECT MENU ITEM			
← BACK 'OK' Select			

10.

Main Menu			
SYSTEM MENU			
Input 1 A/D			
Analog			
↓ SELECT MENU ITEM			
← BACK 'OK' Select			



Press the marked arrow keys of the navigation-pad one after another (like shown in the scheme), to switch the input of channel A to „analogue“ / „digital“ resp. „digital X“ (the selection can be looked up from the LCD display from the respective direction of arrow). After the correct selection of the input of channel A press the OK-button and leave the menu with the left arrow key.

The „Mute- function“

This function enables to mute the PA system with just one touch of a button.

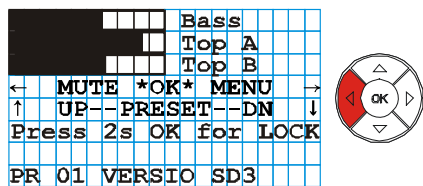

Press for 1 second the marked arrow key of the navigation pad to mute the PA system. A repeated pressing of this arrow key causes the deactivation of the mute-function (see display).

Entering password

You can lock the VSS 15 with or without a password. To lock the VSS 15 with a password (max. 8 digits) you have to enter it first. This password can be changed every time.

Note! Keep in mind resp. note down the entered password because if you want to „unlock“ your VSS 15 you have to enter the password again (see next page). Should you have forgotten the password, you have no possibility to re-activate the VSS 15. Please contact the K.M.E. support! Should the entered password had been cleared, e.g. after a rental, you have to assume a manipulation. Follow now the instructions to activate the menu point!

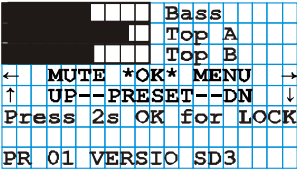
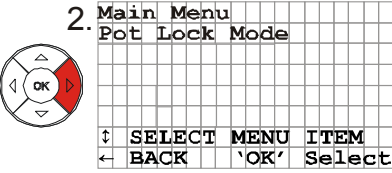
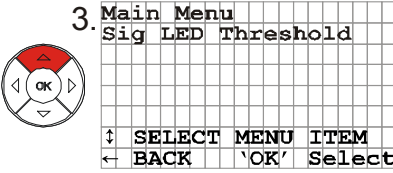
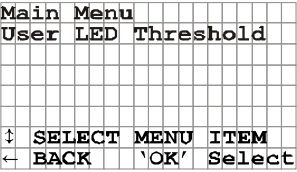
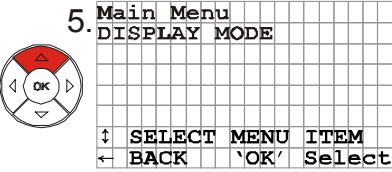
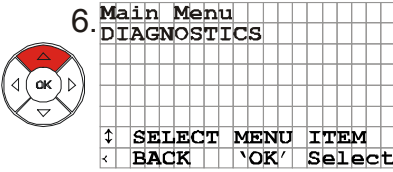
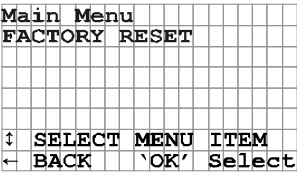
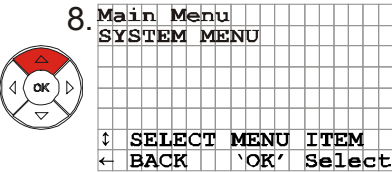
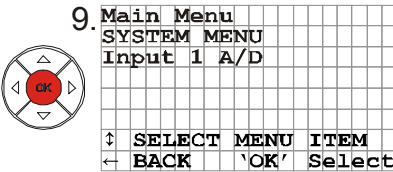
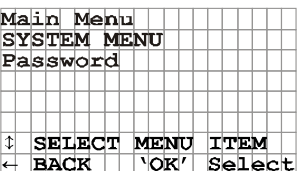
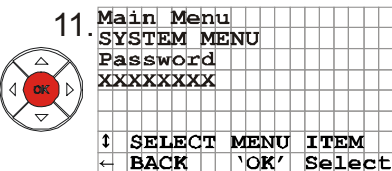
<p>1. </p>	<p>2. </p>	<p>3. </p>
<p>4. </p>	<p>5. </p>	<p>6. </p>
<p>7. </p>	<p>8. </p>	<p>9. </p>
<p>10. </p>	<p>11. </p>	

Press the marked arrow keys of the navigation pad one after another (like shown in the scheme) to open the sub menu „password“. Now you can enter your password with the arrow keys and confirm with OK. You can leave the menu by pressing the left arrow key.

The „Lock-function“

To lock your VSS 15 (with or without password) please do the following instructions: Set all required parameters (also the volume controls) and press, like shown in the graphics, the OK button for 2 seconds and your system is locked (now your VSS 15 is ready for a rental, for example). When switching it off and on again the “lock-function” is re-activated. That means you can not change any settings while the “lock-function” is activated (depending on settings before). To deactivate the “lock-function” you have to press the OK button again for 2 seconds and, if entered before, enter your password by using the arrow keys and confirm with OK.

Attention! If you have changed the position of the volume controls during the VSS 15 was locked you will be informed on the LCD display. Now you have two possibilities to unlock the VSS 15: after entering your password (if entered before) you can press the OK button for two times and the VSS 15 is playing in the current adjustment of the volume controls or you press the OK button only once and turn the volume control(s) to the previous position(s).

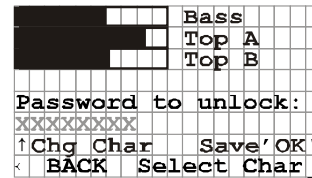
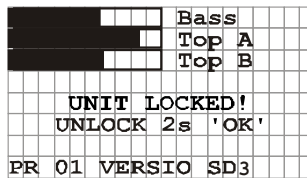
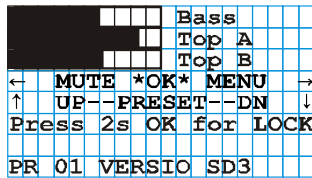

Specifications

	VSS 15
<i>Speaker:</i>	
Components	15" Neodymium
Frequency range	40 Hz – 160 Hz (fx), depending on preset
SPL nominal	101 dB
SPL maximal	128 dB
<i>Electronic:</i>	
Amplifiers	three full digital amplifiers wiht high efficiency, about 90 %
Power output RMS	750 W bass + 2 x 500 @ 4 Ohm
Features	ground-free, navigation pad, LCD- display, adjustable digital crossovers (80 Hz - 160 Hz), subsonic- filter, parametrical EQ's, peak/RMS- limiter, delays (0 - 1000 ms), signal-router
Protective circuits	short circuit, overload, temperature, DC on output
Connectors	analogue: line-in 2 x XLR, line-out 2 x XLR, digital: AES/EBU input & output (XLR), speaker out 2 x Speakon NL 4 Neutrik
Power requirements	90 - 250 Volt / 50 - 60 Hz
Power consumption	1750 W
Control panel	navigation pad, LCD display, multicolor LED, 3 potentiometer
<i>Processor:</i>	
DSP	24 bit, 48 MHz clock
Unit delay	< 1,5 ms
Sampling	24 bit
Digital input & - output	AES/EBU / S/PDIF with format/sample rate converter (max. 192 KHz)
Preset memory	8 factory presets, 4 user presets
Finish	PU coating black
Special features	2 side-mounted handles, M20 fixing plate, stacking elements
Dimensions in mm (B x H x T)	465 x 515 x 590
Weight	26 kg
Recommended units	top units / monitors: VL 8, VL 12, VL 15, passive subwoofer: VB 15
Optional accessory	protective cover (no.2-311-055)

PA-systems active

The active 3-way full-range PA-systems SD 3, SD 4 and SD 5 are professional and powerful PA-systems with extraordinary compact design and a brilliant sound. The different formats / combinations of the VERSIO PA systems are the functional answer to a multiplicity of tasks in mobile use as well as in the area of installation. Simple speech reproduction, fill or delay-systems, presentations, music reinforcement with or without subwoofers as main PA, supported by a versatile accessory assortment enable an accurately to the respective requirements adapted solution. Due to the audio-DSP extensive solutions are available for various using possibilities. The extension of these PA-systems is always possible.

Specifications

	VERSIO SD 3*	VERSIO SD 4*	VERSIO SD 5*
Components	2 x VL 8 (8"+1"), 1 x VSS 15 (15")	2 x VL 12 (12"+1"), 2 x VSS 15 (15")	2 x VL 12 (12"+1"), 2x VB 15 (15") 2 x VSS 15 (15")
Preset no.	preset 1: VERSIO SD3	preset 2: VERSIO SD4	preset 3: VERSIO SD5
Power output	total:1700 W RMS	total: 3500 W RMS (2 x 500 W RMS @ 4 Ohm free configurable)	total: 3500 W RMS
Frequency range	40 Hz – 19 KHz	40 Hz – 19 KHz	40 Hz – 19 KHz
Connectors	audio signal: 2x line-in XLR & link-out XLR (analogue or digital), power requirements: according IEC 60320-C14, speaker outputs: 2x Speakon NL 4 (1+/1-)	audio signal: 2x line-in XLR & link-out XLR (analogue and / or digital), power requirements: according IEC 60320-C14, speaker outputs: 4x Speakon NL 4 (1+/1-)	audio signal: 2x line-in XLR & link-out XLR (analogue or digital), power requirements: according IEC 60320-C14, speaker outputs: 4x Speakon NL 4 (1+/1-)
Weight of components	top: 2 x 9 kg bass: 1 x 26 kg	top: 2 x 15 kg bass: 2 x 26 kg	top: 2 x 15 kg bass: 2 x 22 kg bass: 2 x 26 kg
Recommended for	entertainers, duos	bands, mobile DJs	show- & coverbands
Optional accessories	Plug & Play Pack (no.2-521-007), Cover Pack (no.2-312-016)	Plug & Play Pack (no.2-521-008), Cover Pack (no.2-312-017)	Plug & Play Pack , Cover Pack (no.2-312-018)

**Delivery without distance elements resp. high stands and cables.*

Shemes of connection

VERSIO SD 3 (use preset no. 1)

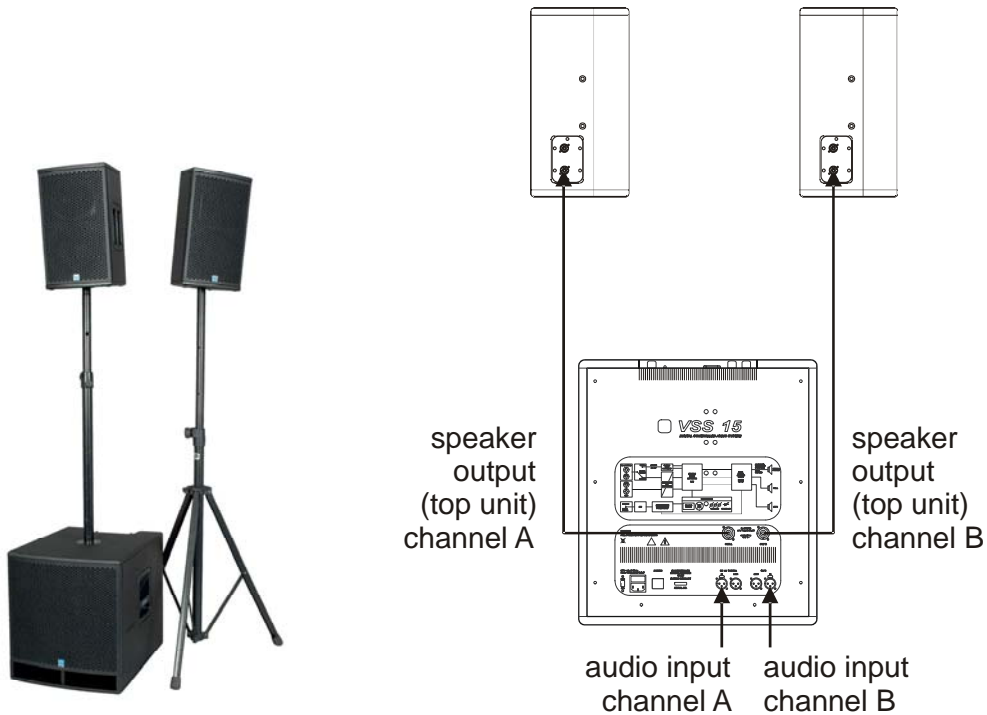

scheme of the power-output connection of SD 3: from speaker outputs “Out A and Out B” into the top units

VERSIO SD 4 (use preset no. 2)

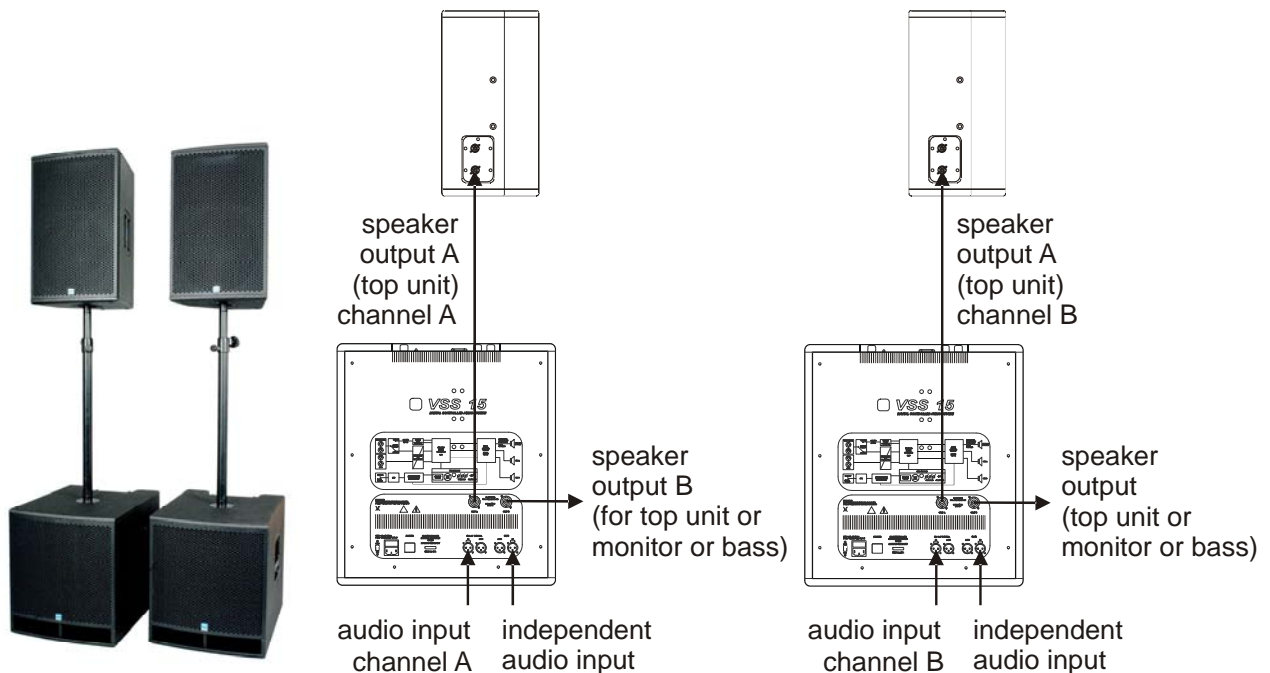

scheme of the power-output connection of SD 4: from speaker outputs “Out A” into each top unit, speaker outputs “Out B” can be free configurable as monitoring resp. delay-line or as bass extension (depending on preset)

VERSIO SD 5 (use preset no. 3)

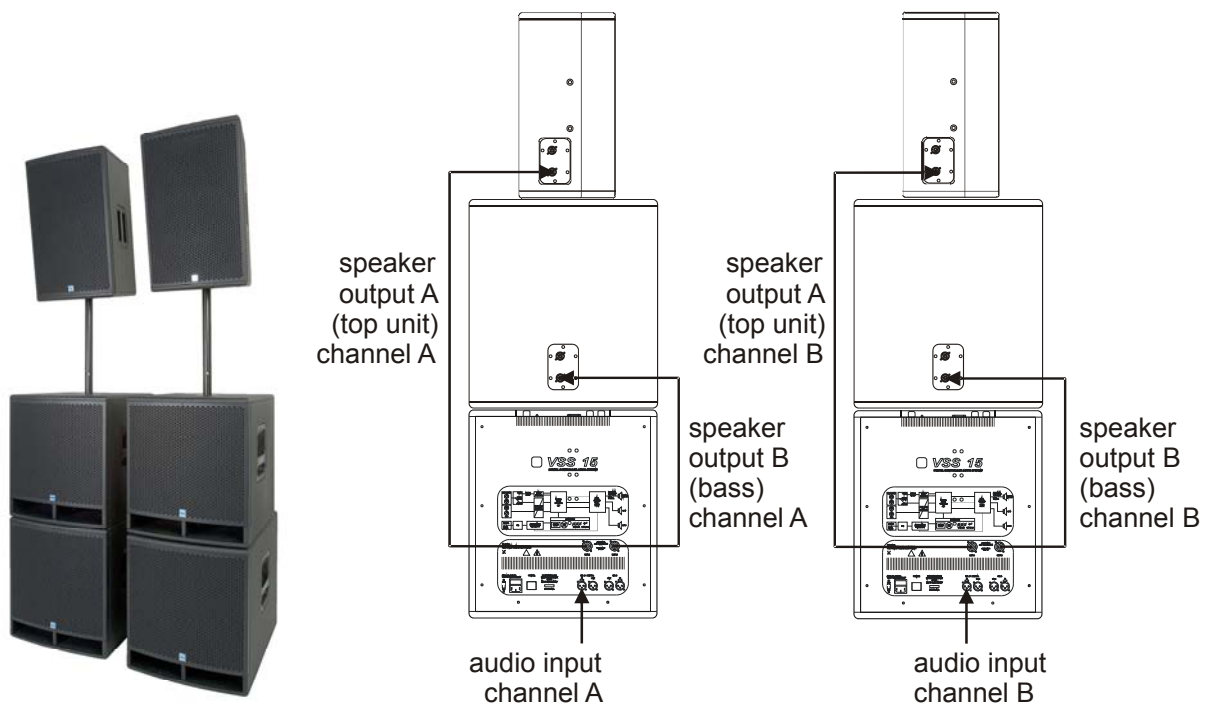

scheme of the power-output connection of SD 5: from speaker outputs “Out A” into each top unit, from speaker outputs “Out B” into each bass

Note!

Please note specific and useful set-up of a first-class loudspeaker system. A universal statement about the correct (standard)-adjustment and set-up of PA systems is impossible, because each reinforcement is bound to a different place and has always different features.

When using high stands or distance rods for top parts the user has to guarantee the stability. Please use just certified mounting material when installing the systems to guarantee the safety. Depending on the features of the area/room to be reinforced the top unit(s) can also be swiveled a bit horizontally and tilted vertically to reduce reflections (on walls + ceilings) and interferences and therefore achieving a better utilization of the sound energy.

The set-up of the PA is followed by the cabling of the power supply and the audio signal in this order:

1. Set-up power supply.*
2. Plug the XLR-cables (audio signal channel A+B) in the VSS 15.
3. When switching on the system please mind that all volume potentiometers are turned fully anti-clockwise / left stop (to avoid an unwanted sound reproduction) and that all connected components are switched on and muted previously because the VSS 15 could start in the „lock-function“ (if saved previously) and for example the volume is set to 0 dB which could cause an immediate reproduction.

*The power supply connection of the PA systems (SD 3 / SD 4 / SD 5) is always made by the supplied IEC plug on a 16A fused electric circuit. Please mind that it is not coming to a ground loop during cabling of the system. If it comes to deep-frequent hum switch the Ground-Free to „Free“. Always use balanced signal cables if possible. Do not mask or detach the conductor connection on the mains plug! *Danger!*

For your notes:

EC declaration of conformity

This is to certify:

Article	Product			Series	Group
1-120-020	VSS 15	PU, black	750 W + 2x 500 W	Versio Series	Subwoofer digital active
1-154-020	Versio SD3 VSS 15 + 2x VL 8	PU, black	1750 W	Versio Series	PA systems active digital
1-154-021	Versio SD4 2x VSS 15 + 2x VL 12	PU, black	2500 W	Versio Series	PA systems active digital
1-154-022	Versio SD5 2x VSS 15 + 2x VB 15 + 2x VL 12	PU, black	3500 W	Versio Series	PA systems active digital

Complies with the provisions of the Directive of the Council of the European Communities on the approximation of laws of the Member States relating to electromagnetic compatibility (EMC Directive 89/336/EEC).

This declaration of conformity of the European Communities is the result of an examination carried out by the Quality Assurance Department of Klingenthaler Musikelektronik GmbH in accordance with European Standards:

VDE	839	Teil 6-1/08.2002	DIN EN 61000-6-1
VDE	839	Teil 6-3/06.2005	DIN EN 61000-6-3
VDE	838	Teil 2/12.2001	DIN EN 61000-3-2
VDE	838	Teil 3/05.2002	DIN EN 61000-3-3
VDE	860	Stand: 01/2003	DIN EN 60065
VDE	875	Teil 1/06.1997	DIN EN 55103-1
VDE	875	Teil 2/06.1997	DIN EN 55103-2

This declaration is given by

Klingenthaler Musikelektronik GmbH
Auerbacher Straße 268
D-08248 Klingenthal

Klingenthal, May 2008



Dieter Glaß
Managing Director

Warranty claims please learn from the warranty card included.

You will find the User Manual of the VERSIO-Series in an other manual or on K.M.E.'s website at www.kme-sound.com.

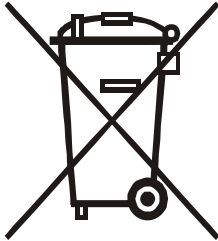

Klingenthaler
Musikelektronik GmbH
Auerbacher Straße 268
08248 Klingenthal Germany
phone +49(0)37467 558-0
www.kme-sound.com



Deutsch Entsorgung von Altgeräten

1. Wenn dieses Symbol eines durchgestrichenen Abfalleimers auf einem Produkt angebracht ist, unterliegt dieses Produkt der europäischen Richtlinie 2002/96/EC.
2. Alle Elektronik-Altgeräte müssen getrennt vom Hausmüll über dafür staatlich vorgesehene Stellen entsorgt werden.
3. Mit der ordnungsgemäßen Entsorgung des alten Gerätes vermeiden Sie Umweltschäden und eine Gefährdung der persönlichen Gesundheit.
4. Weitere Informationen zur Entsorgung des alten Gerätes erhalten Sie bei der Stadtverwaltung, beim Entsorgungsamt oder in dem Geschäft, wo Sie das Produkt erworben haben.

English Disposal of your old appliance

1. When this crossed-out wheeled bin symbol is attached to a product it means the product is covered by the European Directive 2002/96/EC.
2. All electrical and electronic products should be disposed of a separately from the municipal waste stream via designated collection facilities appointed by the government of the local authorities.
3. The correct disposal of your old appliance will help prevent potential negative consequences for the environment and human health.
4. For more detailed information about disposal of your old appliance, please contact your city office, waste disposal service or shop where you purchased the product.



Klingenthaler Musikelektronik GmbH
Auerbacher Straße 268
08248 Klingenthal
Germany
phone +49 (0) 37467-558-0
fax +49 (0) 37467-558-33
service@kme-sound.com
www.kme-sound.com

Technical State Mai 2008.

The content corresponds to the state at printing. Subject to technical alterations. Misprints and errors expected.