

# User Manual

.....  
*Please read this entire manual before operating this device.*

**BOOst™**

Personal Video Magnifier



# Boost™ Personal Video Magnifier

*The Boost™ Personal Video Magnifier is the perfect solution for an active lifestyle. Magnifying up to 17 times in black and white, color, or posterized black and white, Boost™ helps anyone who has trouble reading small type. Boost™ is perfect for busy students reading small-print textbooks, professionals reading a menu in a low light restaurant, or seniors sitting down with their favorite magazine or newspaper.*

Version Number\_1.0 (English Version)

Copyright 2010 by AbleNet, Inc.

All rights reserved



# Table of Contents

Introduction	4
About this manual	4
Safety and caution	5
What's in the box	6
Getting to know your Boost	7
Getting started	8
Power on / off	8
Setting the magnification	8
Viewing modes	9
Image freeze	9
Battery Indicator	9
Specifications	10
Warranty	11

# Introduction

Congratulations on choosing the Boost, an ultra portable Video Magnifier from AbleNet. Use the Boost for reading, writing, viewing map/menu/tips, etc. We hope you enjoy working with your Boost.

## About this manual

This user manual provides a comprehensive guide to the features and operation of the Boost. Pictures in this user manual may be different from the actual situation. AbleNet reserves all the rights for the interpretation of all contents in this user manual. Please read this user manual carefully before using the Boost and keep the user manual in a safe place for future reference.



## Safety and Caution

Do not expose the Boost to extreme or rapid changes in temperature or humidity.

Do not place Boost near a radiator or heater, or where it will be exposed to direct sunlight. These conditions may damage electronics or optics of the Boost.

Handle the Boost with care. Rough handling will damage the internal components.

Do not remove any parts of the Boost. Contact AbleNet to service the Boost if necessary.

Do not open any of the components as this will void the warranty. Each component contains parts which should only be serviced by an AbleNet repair specialist.

Do not use cleaning agents or abrasive materials as they will damage your unit. Avoid touching the lens of the camera and keep it clean by using proper cleaning means.

Use only the power adapter provided.

Do not hit, vibrate, squeeze or drop the equipment with violence.

Do not use the unit under +5°C (41F) or above +40°C (104F).

Use of the Boost other than that described in this user manual will exclude it from warranty conditions.

# What's in the box

The Boost package contains the following:

1. The Boost ultra portable video magnifier
2. A power supply adapter
3. A user manual

If any items are missing from your package, please contact AbleNet.

1



2



3

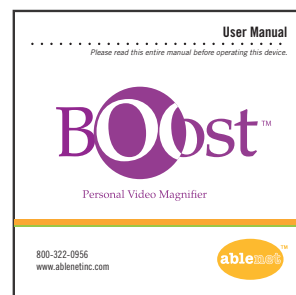

# Getting to know your Boost

The following figure shows the main components of the Boost.

1. Power on/off Viewing modes button
2. Power charging indicator
3. Freeze/Unfreeze mode button
4. DC in
5. Centralized camera
6. Zoom button

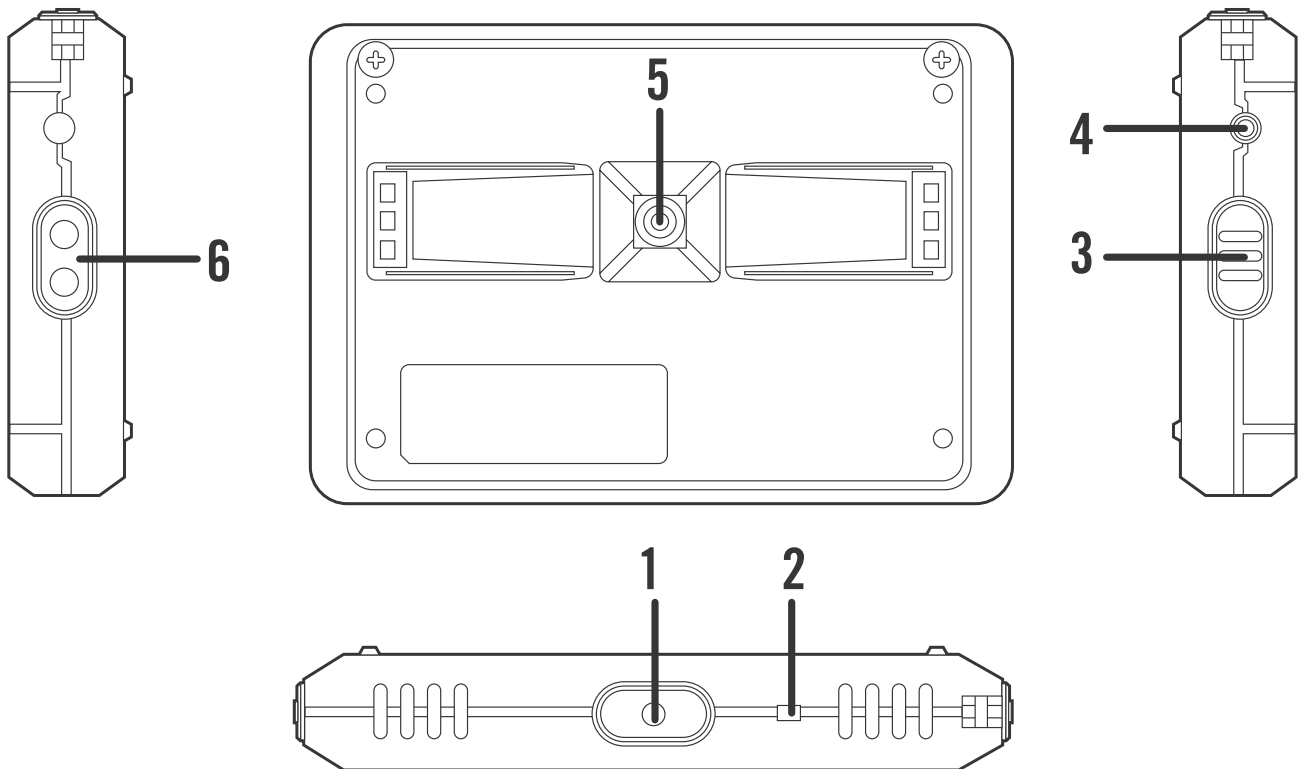

# Getting Started

## Power On/Off

Power On: Press and hold  button for 4 seconds to turn on the device

Power Off: Press and hold button  again for 4 seconds to turn off the device.

After powering on the Boost, viewing mode is initially set to Full Color Mode. For optimal viewing, keep the Boost approximately 1” above the viewing object. Do NOT put the Boost on the object directly.

## Setting the magnification



There are 2 digital magnification levels by pressing the  button. The total combined optical and digital magnification ranges from 1.5X-17X magnification.

Users can also change the distance between the camera lens and target object for getting intermediate degrees of optical magnification.



## Viewing modes

Press the button,  and select the different color modes on the LCD Screen. The Boost has three different color modes available:

-  **Full Color Photo mode** - This mode will display text, pictures and objects in full color.
-  **Negative reading mode** - This mode reverses the positive image. Pictures and text will be displayed as white text on a black background.
-  **Positive reading mode** - This mode enhances the **foreground/background** contrast. Pictures and text will be displayed as black text on a white background.

## Image Freeze

Press  button to freeze the image for a closer look

Press the button again to exit freeze image mode.

In image freeze mode, people can still change the color modes.

## Battery Indicator

The LED beside the viewing modes button is the battery indicator.

Status of the indicator:

- Red light flashing means: the battery needs to be recharged.
- Green light flashing means: the battery is under recharging, once fully charged, the light will be turned off automatically.

## Specifications

Magnification Range	1.5X-17X
Magnification Level	2 Levels
Viewing modes	3 color modes
Image Freeze Frame	Yes
Writing function	Yes
Li-ion Battery Capacity	1500mAh
Battery Working time	2.5 hours
Charging time	2.5-3 hours
LCD Screen size	3.5" TFT LCD
Device Dimension	105X72X17 mm (4.13X2.83X0.67 inches)
Weight	120g (40z)
Power adapter	5V 1.5A