

SIAL 2014

The Global Food Marketplace

Paris Nord Villepinte - France
19 - 23 October 2014

Exhibitor's Guide



an event by
comeXposium
The place to be

SIAL 2014

The Global Food Marketplace

Contacts



an event by
comeXPOSIUM
The place to be

Directory

SIAL 2014 contacts

Valery LOBRY

Managing Director Agriculture & Food Division

Nicolas TRENTESAUX

SIAL Group Director

Sales team	
Commercial Director	
Aude CHABANIER Sales Director E-mail : aude.chabanier@comexposium.com	Chantal de LAMOTTE Sales Deputy Director E-mail : chantal.delamotte@comexposium.com
National Pavilions	
Elly HABT Head of sales E-mail : elly.habt@comexposium.com	<u>Latin America – Southern Europe - Turkey</u> Louis OLARTE Market Manager E-mail : louis.olarte@comexposium.com
<u>Eastern Europe</u> Julie HERNANDEZ Market Manager E-mail : julie.hernandez@comexposium.com	<u>Western Europe - Canada – Africa – Middle East</u> Aline ANDRANIAN Market Manager E-mail : aline.andranian@comexposium.com
<u>Asia and Oceania</u> Lydie BULEON Key account Manager Asia E-mail : lydie.buleon@comexposium-sh.com	
All sectors (apart from pavilions)	Grocery/Confectionary
Alessia CAROLO Sales Manager E-mail : claudie.pouzet@comexposium.com	Claudie POUZET Sales Manager E-mail : claudie.pouzet@comexposium.com
Meat/ Poultry / Cured and salted meat / Seafood products/ Fresh prepared products – Ready to eat	Gourmet Products
Marie-Edmée BERTAIL Sales Manager E-mail : marie-edmee.berail@comexposium.com	Victoire de JENLIS Sales Manager E-mail : victoire.dejenlis@comexposium.com
Beverages (Wines excl.)/Dairy products	In-Food/PAI – Equipment/Technologies/Services
Julien GARCIA Sales Manager E-mail : julien.garcia@comexposium.com	Antoine PAUL Sales Manager E-mail : antoine.paul@comexposium.com
Fruits & Vegetables / Canned foods / Frozen products	Organic & Diet products
Laura BLONDIAUX Sales Manager E-mail : laura.blondiaux@comexposium.com	Nicolas de VERGIE Sales Manager E-mail : nicolas.devergie@comexposium.com

Sales administration (customer service)

Tél. : +33 (0)1 76 77 13 33 / +33 (0)1 40 68 23 00
E-mail : exhibit@sialparis.com

Bérangère BRONDES Account Executive (halls 1, 2, 3, 4 & 8)	Sophie PIANA Account Executive (halls 1, 2, 3, 4 & 8)
Laetitia GUIDEL Account Executive (halls 5A & 6)	Astrid HOUSSAY Account Executive (hall 5B)
Florence BERNARD Account Executive (hall 7)	Audrey CARPENTIER Account Executive (halls 1, 2, 3, 4 & 8)
Axelle DUCHENE Account Executive (halls 5a & 6)	

Sales administration (invoicing and payment)

Tel: +33 (0)1 76 77 13 33
E-mail: DRC.Sial@comexposium.com

Sébé MOUNJONGUE Customers Relationship Manager	Laurence DELIN Customers Relationship Executive
--	---

Technical & logistic team

E-mail: logistics@sialparis.com

Jérôme HUNAUT Operations Director	
Logistic support of the SIAL	
Gilles CRESPON Operations Manager	Julie PLAT Operations Executive
Eric CAUCHOIX Operations Manager	Marion TOMIELLO Operation Assistant

Useful contacts

Hotline SIAL 2014: +33 (0)1 40 68 23 00

From Monday to Friday (9.00 am to 6.00 pm)

Architectural control office	DECOPLUS	1 rue Paul Delaroche 75116 Paris - France Tel: +33 (0)1 47 63 94 84 Contact : Elisabeth TOUGARD E-mail: sialarchi@free.fr
Fire Safety Representative	PHILIPPE WATTEAU	41 rue Lazare Carnot 77340 Pontault-Combault - France Tel: +33 (0)6 85 94 49 57 Fax: +33 (0)1 70 10 40 11 Contact : Philippe WATTEAU E-mail: philippewatteau@numericable.fr
French customs	INFO DOUANES SERVICE	From France : 08 11 20 44 44 (0,06€/mn) From others countries : +33 1 72 40 78 50 Website : www.douane.gouv.fr
Copyright	SACEM	Délégation Régionale de St Gratien 16 avenue Gabriel Péri - BP 103 95210 St Gratien – France Tel: +33 (0)1 76 76 74 80 Website : www.sacem.fr
Accommodations	A.T.I.	8 rue de la Terrasse 75017 Paris - France Tel: +33 (0)1 40 54 64 00 Fax: +33 (0)1 44 05 01 48 E-mail: sial2014@atibooking.com Website : www.atibooking.com
HSP Coordinator	DOT	81 rue de Paris 92100 Boulogne-Billancourt - France Tél : +33 (0)1 46 05 17 85 Contact : Christophe MONNIER E-mail: cm@d-o-t.fr
VAT refund	TEVEA INTERNATIONAL	29-31, rue Saint-Augustin 75002 Paris – France Tél. : +33 (0)1 42 24 96 96 Fax : +33 (0)1 42 24 89 23 E-mail : mail@tevea.com
Fitted stand: - Essentiel Formula - Essentiel + Formula - Essentiel + sectorial Formula - Premium Formula - Premium + Formula - Organic, Gourmet, In-Food & Wine stand	CREATIFS	Tél : + 33 (0)1 45 91 41 40 Fax: + 33 (0)1 45 91 41 50 E-mail: sial2014@creatifs.fr
Fitted stand : - Optimum Formula - Prestige Formula	CAP LINEA	48, rue Charlot 75003 Paris - France Contact : Didier SCHOTT Tél : +33 (0)1 42 71 63 65 E-mail: didier.schott@caplinea.fr Contact : Sylvie BOURSEREAU Tél : +33 (0)1 42 71 63 63 E-mail: sylvie.boursereau@caplinea.fr
Veterinary Service	Direction Départementale des Services Vétérinaires de Seine St Denis	Poste d'Inspection Frontalier Rue du Pélican – Zone de Frêt 1 –BP 10111 95701 Roissy Charles de Gaulle Cedex – France E-mail: pif-aeroport.ddsv93@agriculture.gouv.fr

List of partners

Below is a list of potential suppliers who can help you meet your requirements.

Stand Security	GPS - GARDIENNAGE PROTECTION SERVICE	3 rue Labouret 94220 Charenton le Pont – France Tel: +33 (0)1 43 96 12 09 Fax: +33 (0)1 43 53 36 18 Contact : Cristiana FERNANDES E-mail: cfernandes@gps-securite.fr Website : www.gps-securite.fr
Hostesses	MAHOLA Hôtesses	3 rue Cambronne 75740 Paris cedex 15 - France Tel: +33 (0)1 53 58 61 00 Fax: +33 (0)1 53 58 61 01 Contact : Emmanuelle LEBRETON E-mail: elebreton@mahola-hotesses.fr Website : www.mahola-hotesses.fr
Hostesses	CARLITA Event	90 rue de Paris 92100 BOULOGNE BILLANCOURT Phone : +33 (0) 1 55 60 26 01 Fax : +33 (0) 1 55 60 05 95 Contact : Aurélie CANET Email : contact@carlita-event.com Website : www.carlita-event.com
Rental industrial refrigerated furniture	LOWE - Worldwide Refrigeration	Unit J – Knockmore Industrial Estate Lisburn, Co. Antrim, Northern Ireland - BT 28 2EJ Tél : +44 (0) 2892 604 619 Fax: +44 (0) 2892 660 849 Contact : Mme Kelly PARKER E-mail: reservations@loweref.com Website : www.lowe-europe.com
Events & receptions	CARLE ORGANISATION	103 rue de Sèvres 75006 Paris - France Tél : 01 53 63 01 01 Fax: +33 (0)1 53 63 02 02 Contact : Jennifer CASTEL E-mail: jcastel@carle-organisation.fr Contact : François RAYMOND E-mail: fraymond@carle-organisation.fr
Restoration: delivery on stand	HORETO	Tél : +33 (0)1 48 63 33 45 E-mail: vssvillepinte@horeto.com Website : www.horeto.com
Restoration: delivery on stand	ELIOR	Tél : +33 (0)1 48 63 32 00 E-mail: elior.villepinte@elior.com Website : www.elior-parcexpos.com
Carriers and Movers	AGILITY FAIRS & EVENTS	Parc des Expositions de Paris Nord Villepinte Bâtiment M2 - BP 66135 93420 Villepinte - France Tel: +33 (0)1 48 63 33 81 Fax: +33 (0)1 48 63 33 82 Contact : Abdi EL HOUARI E-mail: fairs-france@agilitylogistics.com Website : www.agilitylogistics.com

Contacts (cont.)

<p>Carriers and Movers</p>	<p>CLAMAGERAN FOIREXPO</p>	<p>Parc des Expositions de Paris-Nord Villepinte BP 64137 95976 Roissy CDG cedex - France Tél. : +33 (0)1 48 63 32 47 Fax : +33 (0)1 48 63 32 38 Contact : Dominique FILIBERTI Email : d.filiberti@clamageran.fr Site Internet : www.clamageran.com</p>
<p>Carriers and Movers</p>	<p>DB SCHENKER Foires et Expositions France</p>	<p>Parc des Expositions de Paris Nord Villepinte Bâtiment M 1 – Derrière le hall 3 BP 14216 95703 Roissy CDG cedex - France Tel: +33 (0)1 48 63 32 81 Fax: +33 (0)1 48 63 32 82 Contact : Pauline VILLEMAINE E-mail: pauline.villemaine@dbschenker.com Website : www.schenker.fr</p>
<p>Carriers and Movers</p>	<p>EXPO SERVICES INTERNATIONAL (ESI)</p>	<p>Parc des Expositions de Paris Nord II Bâtiment des Transitaires 93420 Villepinte Contact : Gérard GUENARD Tél. : +33 (0)1 48 63 32 70 / +33 (0)6 07 74 78 62 Fax : +33 (0)1 48 69 32 74 Email : gerard.guenard@group-esi.com Site Internet : www.group-esi.com</p>



Access conditions - Assembly
Opening - Dismantling



an event by
comeXposium
The place to be

Conditions of access

Exhibitors schedule of hours

HINTS: Please give the right address to yours transporters and delivery-man:
Parc des Expositions de Paris Nord Villepinte – SIAL 2014
Hall n° Stand n° (letter + figure)
ZAC de Paris Nord II – C.D.40 – 93420 VILLEPINTE - France

Parc des Expositions de Paris Nord Villepinte Access

➤ By RER – Which line to take?

- **From Paris:**
RER line B, direction Roissy. 19mn from the Gare du Nord station. 22 mn from Châtelet station.
- **From Roissy-Charles de Gaulle Airport:**
RER line B, direction Robinson - Saint Rémy les Chevreuse. Get off the train at the first station **Parc des Expositions**.
- **From Orly Airport:**
Take Orly-Val up to Antony station, then RER B - direction Roissy-Charles de Gaulle 2 - TGV, and get off at the "Parc des expositions" station
- **Where to alight**
"Parc des Expositions" station on RER B.

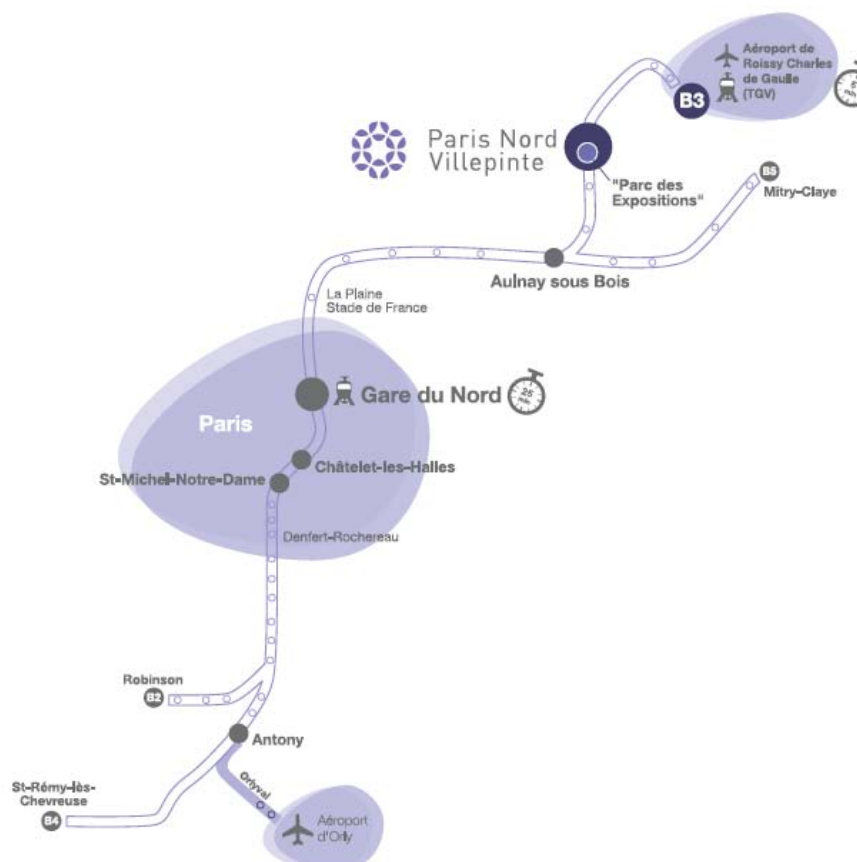

BEWARE!

Do not get off the train at Villepinte: this stop has no access to the Parc des Expositions.
To get to SIAL, you must alight at "Parc des Expositions".
More information on www.ratp.fr

Conditions of access - Exhibitors schedule of hours (cont.)

SIAL tips to travel with peace of mind:

- To make your trip easy, remember to purchase **your return RER ticket in the morning** to avoid queuing at the ticket office in the evening when the exhibition closes.
- The Parc des Expositions de Villepinte station is situated on the RER B line in **zone 4** (outside inner Paris), which is the Ile de France price bracket for tickets.
- **Ordinary Paris metro tickets are not valid** for travelling to Parc des Expositions
- RER tickets are **non-refundable and non-exchangeable**

➡ By Road

• From the north of Paris

Take the A1 motorway (Porte de la Chapelle) or A3 motorway (Porte de Bagnole), then the A104 motorway (direction: Soissons). Then follow the signs to the "Parc des Expositions" entrance.

• From the south of Paris

Take the A86 or A6 motorway towards Paris, followed by the A1 or A3 and then the A104 direction Soissons. Follow signs to "Parc des Expositions". And go to Visitors' or exhibitors area

→ Map out your itinerary on www.mappy.fr

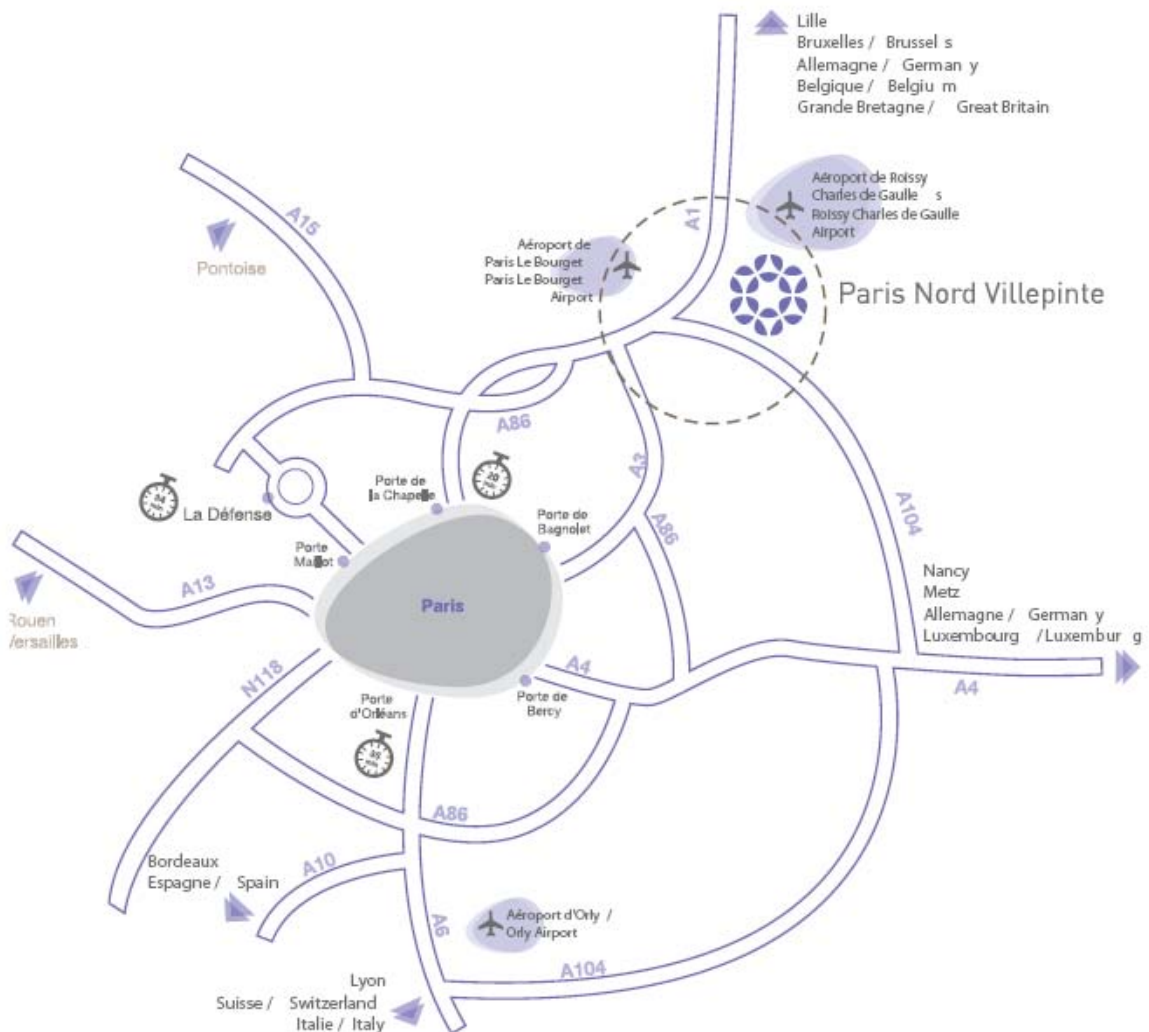

Conditions of access - Exhibitors schedule of hours (cont.)

By train

- The Parc des Expositions de Paris Nord Villepinte is 5 mins. away from the Roissy Charles de Gaulle TGV station : CDG 2 TGV
- Access from Gare du Nord (Thalys / Eurostar) via the RER line B
- Access from Gare de Lyon via the RER line A and RER line B

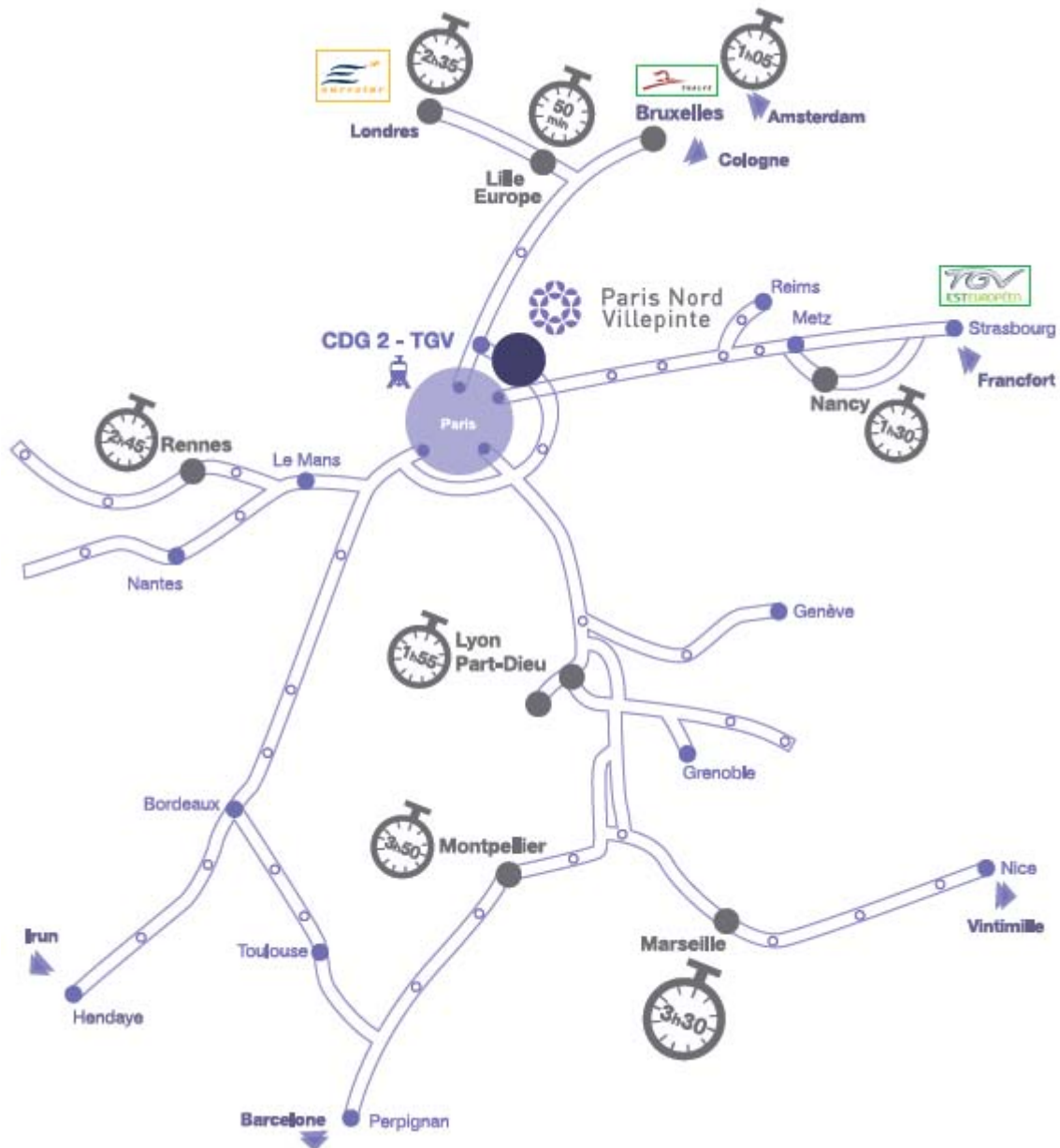

➔ By plane

AIR FRANCE & KLM Global Meetings

You intend to travel to SIAL by air? On arrival at either of the international airports Roissy Charles de Gaulle and Orly, the RER B train will take you to the Parc des Expositions de Paris Nord Villepinte.

➔ Two international airports to get to SIAL

• Roissy Charles de Gaulle airport

The Parc des Expositions is located 5 mins. away from Roissy Charles de Gaulle airport.

Take the RER B – direction: Robinson-Saint Rémy lès Chevreuse and get off at the first stop: Parc des Expositions.

• Orly airport

Take the Orly-Val (light automated metro) to Antony, then take the RER B (direction: Roissy-Charles de Gaulle). Get off at Parc des Expositions.

➔ Attractive discounts on a wide range of airfares on all Air France and KLM flights worldwide**.

- Event : **SIAL 2014**
- Event ID : **21263AF**
- Valid for transport **from 14/10/2014 to 28/10/2014**
- Event location : Parc des Expositions de Paris Nord Villepinte, France

Use the website of this event or visit www.airfranceklm-globalmeetings.com to:

- Access the preferential fares granted for this event*,
- Make your booking,
- Issue your electronic ticket*,
- Select your seat**.

If you buy your ticket via AIR FRANCE & KLM Global Meetings website, your electronic ticket will carry a special mention which justifies the application of the preferential fares.

Should you prefer to process your reservations and ticket-purchase directly with an Air France and KLM sales outlet, you must keep this current document which serves to justify the application of the preferential airfares

Keep the document to justify the special fares with you as you may be asked for it at any point of your journey.

Frequent flyer / loyalty programs of Air France and KLM partner airlines are credited with "miles" when Air France or KLM flights are used.

* Subject to conditions

** Not available in certain countries

Traffic and rules for driving in the Exhibition Centre

- Observance of the highway code,
- Speed limit: 20 km/h,
- No stopping and no parking in traffic lanes,
- No passenger cars will be allowed into the halls,
- Lorries will be allowed access under specific conditions and subject to traffic control.

We would appreciate if you would comply with the above provisions and inform your installers, road hauliers and suppliers thereof.

Access, traffic and parking instructions during the exhibition

- Deliveries are authorized from 7:30 am to 9:00 am.
- Parking and storage of any sort are not authorized within the Parc des Expositions de Paris Nord Villepinte.
- Parking is prohibited in the safety zones when the exhibition is open to the public.

All contravening vehicles will be towed away without prior notice at their owners' risk and expense.

CAUTION: We thank you to plan your deliveries because of circulation restrictions in France during weekends. **For more information:** www.bison-fute.equipement.gouv.fr

Exhibitors' schedule of hours

ONE-STOP SERVICES PORTAL: A FACILITY TO IMPROVE SERVICE

Place all your orders, including the services provided by the Parc des Expositions de Paris, in your Exhibitors Area Topic "My Store"

THE EXHIBITOR SERVICE DESK ON SITE

Organiser's Offices will be located in the **Halls 3, 5a, 5b and 7.**

➤ Exhibition opening hours

Dates	Exhibition opening hours
Sunday October 19th	9.30 am – 6.00 pm
Monday October 20th	9.30 am – 6.00 pm
Tuesday October 21st	9.30 am – 6.00 pm
Wednesday October 22nd	9.30 am – 6.00 pm
Thursday October 23rd	9.30 am – 5.00 pm

➤ Working hours (set up – dismantling – power supply)

	Dates	Exhibitors hours	Power supply hours
BUILD-UP	Bare Stands ⁽¹⁾	Tuesday October 14 th	7.30 am – 7.30 pm
		Wednesday October 15 th	7.30 am – 7.30 pm
		Thursday October 16 th	7.30 am – 7.30 pm
BUILD-UP	Bare Stands Fitted Stands ⁽²⁾	Friday October 17 th	7.30 am – 10.00 pm
		Saturday October 18 th	7.30 am – 10.00 pm
OPENING		Sunday October 19 th	7.30 am – 7.30 pm
		Monday October 20 th	8.30 am – 7.30 pm
		Tuesday October 21 st	8.30 am – 7.30 pm
		Wednesday October 22 nd	8.30 am – 7.30 pm
		Thursday October 23 rd	8.30 am – 5.00 pm
DISMANTLING	Bare Stands Fitted Stands ⁽²⁾	Thursday October 23 rd	5.00 pm – 12.00 pm
		Friday October 24 th	7.30 am – 7.30 pm
	Bare Stands ⁽³⁾	Saturday October 25 th	7.30 am – 7.30 pm
		Sunday October 26 th	7.30 am – 2.00 pm

(1) Hall 8 : build-up beginning : Wednesday October 15th at 8.00 am
Power supply : from Thursday October 16th, 2,00 pm

(2) Essentiel, Essentiel+, Premium, Premium+, Optimum and Prestige fitted Stand

(3) Hall 8 : end of dismantling : Saturday October 25th at 2.00 pm

Advice

To get power supply outside these hours, don't forget to order 24-hour power supply.

Build-up - Dismantling

Build up

- During installation and dismantling, exhibitor's car parks are free.
- **No cars will be allowed inside the halls.**
- **Lorrie's traffic** will be controlled.
- Empty packing materials must be **removed immediately and stored by the exhibitors or their freight carriers.**
- **Storage space on stands must not be used to keep packing materials** or any other goods that could constitute a fire hazard.
- Setting up must be completed by the time the **Safety Commission** makes its inspection. The person in charge of your stand must be present at this time. Date and time will be announced later.
- **No motor vehicles will be allowed into the halls on Saturday 18th October** (unless special permission is granted by the organizer).
- To enter the exhibition Halls during installation and dismantling, **all personnel must wear personal safety equipment**, in particular safety shoes. Otherwise, access to the exhibition will be refused.
- For safety reasons, work in the halls is forbidden outside the specified hours on **Working hours**.

Stand security

- The SIAL ensures the general security of the exhibition in the best conditions, but cannot provide for the individual guarding of stands. This is an obligation to provide means, and not to achieve results.
- Exhibitors who intend to have their stands specifically guarded (this is strongly advised) should inform the Organizer and give the names of the persons who will be present on the stand, and the name of the security company.
- The exhibitor is responsible for his stand and must take all necessary measures to protect his equipment and remove it in the evening when the exhibition closes, if he does not provide for special guarding.
- Stand storerooms are not secured premises.

There are important risks of theft during the set-up and dismantling periods:

Keep all equipment and items likely to be stolen out of sight (e.g. plasma screens, computers, personal effects).

To be on the safe side, it is strongly recommended that you watch closely over your stand and ensure that someone is always present until dismantling is completed.

This presence is your only safeguard against theft.

Dismantling

- We recommend you to inform your forwarding agents; freight carriers and contractors that goods removal shall be completed at the dates and times specified in the exhibitor's entry / exit schedule.
- **All turnkey stands will be dismantled on Thursday 23rd October.** Exhibitors are therefore kindly requested to remove their goods and personal effects on the evening when the exhibition closes, i.e. on Thursday 23rd October between 5.00 pm and 8.00 pm.
- **Motor driven appliances** are not allowed in the exhibition area **before 7.00 p.m.**

Build-up - Dismantling (cont.)

- Handlers will start to deliver empty packing materials stored at your request on your stand on the **Thursday 23rd October from 7.00 p.m. at the earliest.**
- **All equipments and decorations must be removed from the halls on Sunday 26th October, for 2.00 p.m. at the latest, and on Saturday 25th October, for 2.00 p.m. at the latest for the hall 8.** The goods and equipments not requiring dismantling, and which are not removed within the given delays, will be stored by the organiser at the exhibitor's expense. On the other hand, the organiser reserves the right to destroy, at the exhibitor's expense, the stand and decor structures of whatever type which have not been dismantled by the exhibitor within the given delays. No claim will be accepted in this respect.

Stands cleaning – Waste removal

➤ During installation and dismantling period:

- Cleaning provider will be present at the General Commissioner's Office located in Hall 3, 5a, 5b and 7.
- To rent small waste bins, please order it on your Exhibitor's Area, topic "**My Store**"

All materials and decorative items must be removed by the end of dismantling period. If this is not the case, all installations and decorative structures will be removed and disposed of by organizer **at the expense, risk and peril of the exhibitor**. This operation will be invoiced to the exhibitor.

Advice

If you choose to hire a decorator outside your company, make sure the quote includes many references to "installation", "deposits" and abductions waste, otherwise let them add.



Setting up of your stand



an event by
comeXPOSIUM
The place to be

You have booked a bare stand

Stand > 24 sqm

Included services

- **Your space marked on the floor**, without partitions
- **A sign on the floor** with your stand number.
- **Daily clean-up** of your stand including:

- Bins emptied
- Floor vacuumed
- Counters and furniture wiped down

Not included:

- Removal of protective plastic cover from carpet
- Set-up the night before opening
- Cleaning exhibited machines/items
- Bins
- Mandatory removal of spent fluids.

How to set up your stand

➤ Step 1: ordering your stand

SIAL will send you a plan for your stand by post or by email for your approval. Once confirmed, this plan will be used to fit-out your stand with your selected décor.

Our advice

Make your life easier and **book the “fitted” stand package** in the Exhibitors’ Area, under “**My Boutique**”, or contact us for details of our **custom stands** under “**My Forms**”.

➤ Step 2: order any technical services (electric connections, phone lines, parking facilities, etc.)

- Find all available services in your Exhibitors’ Area, under “**My Boutique**”.

➤ Step 3: plan approval

- Your stand’s decoration plan must be submitted to SIAL architects **before 4th July 2014, together with your stand fitting form.**

DECO PLUS
1, rue Paul Delaroche
75116 PARIS - FRANCE
Tel: +33 (0)1 47 63 94 84 - Fax: +33 (0)1 43 80 59 63
Email: sialarchi@free.fr

- Check which details to provide in the **Architecture and Decoration Regulations** in your Exhibitor’s Area under “**My Regulations**”.

You have booked a bare stand (cont.)

➤ Step 4: your stand at the fair

Please check the assembly schedule in your Exhibitor's Area under "**Practical Information/Schedule**".

Health and Safety

MANDATORY
Health and Safety Notice
(HSP: Health and Safety Plan).

- The Health and Safety Notice should be completed by Exhibitors, and can be found in the Exhibitor's Area under "**My Forms**".
- **The Notice must be distributed to all suppliers and sub-contractors.**
- You must be wearing a SIAL access badge (Exhibitor/Service Provider Badge) as well as proper safety equipment (safety boots, helmets, etc.) in order to enter the hall. Failure to meet these conditions will result in you being refused entry to the hall.
- The HSP must be validated before receiving authorization to enter the hall

Additional services

SIAL provides a full range of services to improve the organization of your stand and to optimize your presence at the fair. Details can be found in the Exhibitor's Area, under "**My Boutique**".

➤ Additional services to be ordered before stand is fitted:

- Additional fittings (carpet, flooring, stock, partitions, lighting, etc.)
- Furniture,
- Refrigeration,
- Flowers,
- Videos, office equipment,
- Coffee machine

Be sure to order in advance as stock is limited once fitting has begun.

- If you book additional service while the fair is being fitted, they must be ordered as soon as possible, and certainly before the fair, in order to guarantee the best possible variety of ranges, colour schemes, sizes, and delivery dates.
- On site, ordered services will be provided while stocks last.

➤ Other additional services: security, hosting, catering, handling.

See the **list of Partners** in the "**Practical Information**" section of your Exhibitor's Area.

➤ Cleaning/Waste removal

During fitting and dismantling:

- SIAL is available and more than happy to provide you with an estimate for disposing of your equipment.
- To order clean-up skips, see the "**My Boutique**" section.

You have booked a bare stand (cont.)

All stands, equipment, merchandise and waste (stickers, carpet, etc.) absolutely must be removed before the end of dismantling.

If you do not make use of the services provided by the organizer, then you are responsible for removing and disposing of all products, **in line with current legislation**.

Once the fitting deadlines have passed, the Organizer may, **at the cost and liability of the exhibitor**, take any measures deemed useful to dispose of the remaining equipment and waste on the pitch, as well as the destruction of structures and decoration of any kind that have not been dismantled.

Recommendation

If you outsource decorator services, be sure that your quote includes “fitting”, “dismantling”, and waste removal, and add them if they are not featured on the quote.

The Essential fitted stand

From 16 sqm



Non-contractual picture

Fittings included with your stand

- ➔ Carpet and modular melamine partitions (Choose from 4 harmonies below)

	CLOISON MÉLAMINÉ / MELAMINE PANEL	MOQUETTE / CARPET	STRUCTURE / FRAME
HARMONIE 1	Blanc / White	Vert / Green	Blanc / White
HARMONIE 2	Bouleau / Birch wood	Rouge / Brick Red	Blanc / White
HARMONIE 3	Titane / Titanium	Bleu / Blue	Titane / Titanium
HARMONIE 4	Blanc / White	Gris clair / Light grey	Titane / Titanium

- ➔ 1 sqm storage area (2 sqm for stands over 24 sqm)
- ➔ 1 stand sign flag with text (for each open side)
- ➔ Lighting with 100W spotlights (1 for every 3 sqm)
- ➔ 1 triple socket (in the storage area)
- ➔ 3kW fused power supply (daytime only)*
- ➔ Furniture: 1 table and 3 chairs (white)
- ➔ 1 reception desk and a high stool over 24 sqm
- ➔ Daily cleaning (including a final preparation cleaning the day before the opening)

How to set up your stand

➤ Step 1: checking the equipment included with your stand

A SIAL fitted stand advisor will contact you directly about your choice of colour scheme, the positioning of your storage and sign, your choice of furniture, and the various services included with your stand.

➤ Step 2: order any technical services

(extra power supply, telephone lines, parking, audiovisual equipment, etc.)

The SIAL fitted stand advisor will confirm all additional services required to organize your stand:

Additional services to be ordered before stand is fitted:

- Additional furnishings, refrigeration, extra flowers,
- Audio-visual equipment, office equipment, etc.

Be sure to order in advance as stock is limited once fitting has begun.

- If you book additional services, they must be ordered as soon as possible and certainly before the fair, in order to guarantee the best possible variety of ranges, colour schemes, sizes, and delivery dates.
- On site, ordered services will be provided while stocks last.

Other additional services: Security, hosting, catering, handling.

See the **list of Partners** in the “**Practical Information**” section of your Exhibitor’s Area.

➤ Step 3: Health and Safety

The Health and Safety Notice must be completed in the Exhibitor’s Area under “**My Forms**”.

➤ Step 4: delivery of your stand on Wednesday 17th October 2014 at 9 am.

***For all stands with fresh products, remember to order a permanent 24h electricity supply, not included as standard**

The Essential + fitted stand

From 16 sqm



Non-contractual picture

Fittings included with your stand

- ➔ Carpet and Wooden partitions covered with brush cotton (choose from 4 harmonies below)

	MOQUETTE / CARPET	COTON / BRUSH COTTON
HARMONIE 1	Vert / Green	Gris / Grey
HARMONIE 2	Rouge / Brick Red	Beige
HARMONIE 3	Bleu / Blue	Beige
HARMONIE 4	Gris clair / Light grey	Gris / Grey

- ➔ 1 sqm storage area (2 sqm for stands over 24 sqm)
- ➔ 1 stand sign flag with text (for each open side)
- ➔ Lighting with 100W spotlights (1 for every 3 sqm)
- ➔ 1 triple socket (in the storage area)
- ➔ 3kW fused power supply (daytime only)*
- ➔ Furniture: 1 table and 3 chairs (white)
- ➔ 1 reception desk and a high stool over 24 sqm
- ➔ Daily cleaning (including a final preparation cleaning the day before the opening)

How to set up your stand

➤ Step 1: checking the equipment included with your stand

A SIAL fitted stand advisor will contact you directly about your choice of colour scheme, the positioning of your storage and sign, your choice of furniture, and the various services included with your stand.

➤ Step 2: order any technical services

(extra power supply, telephone lines, parking, audio-visual equipment, etc.)

The SIAL fitted stand advisor will confirm all additional services required to organize your stand:

Additional services to be ordered before stand is fitted:

- Additional furnishings, refrigeration, extra flowers,
- Audio-visual equipment, office equipment, etc.

Be sure to order in advance as stock is limited once fitting has begun.

- If you book additional services, they must be ordered as soon as possible and certainly before the fair, in order to guarantee the best possible variety of ranges, colour schemes, sizes, and delivery dates.
- On site, ordered services will be provided while stocks last.

Other additional services: Security, hosting, catering, handling.

See the **list of Partners** in the “**Practical Information**” section of your Exhibitor’s Area.

➤ Step 3: Health and Safety

The Health and Safety Notice must be completed in the Exhibitor’s Area under “**My Forms**”.

➤ Step 4: delivery of your stand on Wednesday 17th October 2014 at 9 am.

***For all stands with fresh products, remember to order a permanent 24h electricity supply, not included as standard.**

The Essential + Organic Products fitted stand

From 16 sqm



Non-contractual picture

Fittings included with your stand

- ➔ Pistachio carpet and Wooden partitions covered with beige cotton gloss
- ➔ 1 sqm storage area (2 sqm for stands over 24 sqm)
- ➔ 2 wall shelves
- ➔ 1 stand sign flag with text (for each open side)
- ➔ Lighting with 100W spotlights (1 for every 3 sqm)
- ➔ 1 triple socket (in the storage area)
- ➔ 3kW fused power supply (daytime only)*
- ➔ Furniture: 1 table and 3 chairs (white) + 1 counter and 1 stool
- ➔ Daily cleaning (including a final preparation cleaning the day before the opening)

How to set up your stand

➔ Step 1: checking the equipment included with your stand

A SIAL fitted stand advisor will contact you directly about your choice of colour scheme, the positioning of your storage and sign, your choice of furniture, and the various services included with your stand.

The Essential + Organic products fitted stand (cont.)

➤ Step 2: order any technical services

(extra power supply, telephone lines, parking, audio-visual equipment, etc.)

The SIAL fitted stand advisor will confirm all additional services required to organize your stand:

Additional services to be ordered before stand is fitted:

- Additional furnishings, refrigeration, extra flowers,
- Audio-visual equipment, office equipment, etc.

Be sure to order in advance as stock is limited once fitting has begun.

- If you book additional services, they must be ordered as soon as possible and certainly before the fair, in order to guarantee the best possible variety of ranges, colour schemes, sizes, and delivery dates.
- On site, ordered services will be provided while stocks last.

Other additional services: Security, hosting, catering, handling.

See the **list of Partners** in the “**Practical Information**” section of your Exhibitor’s Area.

➤ Step 3: Health and Safety

The Health and Safety Notice must be completed in the Exhibitor’s Area under “**My Forms**”.

➤ Step 4: delivery of your stand on Wednesday 17th October 2014 at 9 am.

***For all stands with fresh products, remember to order a permanent 24h electricity supply, not included as standard.**

The Essential + Wine fitted stand

From 16 sqm



Non-contractual picture

Fittings included with your stand

- ➔ Bordeaux carpet and Wooden partitions covered with beige cotton gloss
- ➔ 1 sqm storage area (2 sqm for stands over 24 sqm)
- ➔ 2 wall shelves
- ➔ 1 stand sign flag with text (for each open side)
- ➔ Lighting with 100W spotlights (1 for every 3 sqm)
- ➔ 1 triple socket (in the storage area)
- ➔ 3kW fused power supply (daytime only)*
- ➔ Furniture: 1 table and 3 chairs (white) + 1 counter and 1 stool
- ➔ Daily cleaning (including a final preparation cleaning the day before the opening)
- ➔ A spittoon, removal of your empty bottles
- ➔ Supply of glasses (24 / day) and washing each end of day
- ➔ Washing area

How to set up your stand

➤ Step 1: checking the equipment included with your stand

A SIAL fitted stand advisor will contact you directly about your choice of colour scheme, the positioning of your storage and sign, your choice of furniture, and the various services included with your stand.

➤ Step 2: order any technical services

(extra power supply, telephone lines, parking, audio-visual equipment, etc.)

The SIAL fitted stand advisor will confirm all additional services required to organize your stand:

Additional services to be ordered before stand is fitted:

- Additional furnishings, refrigeration, extra flowers,
- Audio-visual equipment, office equipment, etc.

Be sure to order in advance as stock is limited once fitting has begun.

- If you book additional services, they must be ordered as soon as possible and certainly before the fair, in order to guarantee the best possible variety of ranges, colour schemes, sizes, and delivery dates.
- On site, ordered services will be provided while stocks last.

Other additional services: Security, hosting, catering, handling.

See the **list of Partners** in the “**Practical Information**” section of your Exhibitor’s Area.

➤ Step 3: Health and Safety

The Health and Safety Notice must be completed in the Exhibitor’s Area under “**My Forms**”.

➤ Step 4: delivery of your stand on Wednesday 17th October 2014 at 9 am.

***For all stands with fresh products, remember to order a permanent 24h electricity supply, not included as standard.**

The Essential + Gourmet fitted stand

From 16 sqm



Non-contractual picture

Fittings included with your stand

- Purple carpet and Wooden partitions covered with beige cotton gloss
- 1 sqm storage area (2 sqm for stands over 24 sqm)
- 2 wall shelves
- 1 stand sign flag with text (for each open side)
- Lighting with 100W spotlights (1 for every 3 sqm)
- 1 triple socket (in the storage area)
- 3kW fused power supply (daytime only)*
- Furniture: 1 table and 3 chairs (white) + 1 counter and 1 stool
- Daily cleaning (including a final preparation cleaning the day before the opening)

How to set up your stand

➤ Step 1: checking the equipment included with your stand

A SIAL fitted stand advisor will contact you directly about your choice of colour scheme, the positioning of your storage and sign, your choice of furniture, and the various services included with your stand.

The Essential + Gourmet fitted stand (cont.)

➤ Step 2: order any technical services

(extra power supply, telephone lines, parking, audio-visual equipment, etc.)

The SIAL fitted stand advisor will confirm all additional services required to organize your stand:

Additional services to be ordered before stand is fitted:

- Additional furnishings, refrigeration, extra flowers,
- Audio-visual equipment, office equipment, etc.

Be sure to order in advance as stock is limited once fitting has begun.

- If you book additional services, they must be ordered as soon as possible and certainly before the fair, in order to guarantee the best possible variety of ranges, colour schemes, sizes, and delivery dates.
- On site, ordered services will be provided while stocks last.

Other additional services: Security, hosting, catering, handling.

See the **list of Partners** in the “**Practical Information**” section of your Exhibitor’s Area.

➤ Step 3: Health and Safety

The Health and Safety Notice must be completed in the Exhibitor’s Area under “**My Forms**”.

➤ Step 4: delivery of your stand on Wednesday 17th October 2014 at 9 am.

***For all stands with fresh products, remember to order a permanent 24h electricity supply, not included as standard.**

The Essential + IN-FOOD / PAI fitted stand

From 16 sqm



Non-contractual picture

Fittings included with your stand

- Turquoise carpet and Wooden partitions covered with beige cotton gloss
- 1 sqm storage area (2 sqm for stands over 24 sqm)
- 2 wall shelves
- 1 stand sign flag with text (for each open side)
- Lighting with 100W spotlights (1 for every 3 sqm)
- 1 triple socket (in the storage area)
- 3kW fused power supply (daytime only)*
- Furniture: 1 table and 3 chairs (white) + 1 counter and 1 stool
- Daily cleaning (including a final preparation cleaning the day before the opening)

How to set up your stand

➤ Step 1: checking the equipment included with your stand

A SIAL fitted stand advisor will contact you directly about your choice of colour scheme, the positioning of your storage and sign, your choice of furniture, and the various services included with your stand.

The Essential + IN-FOOD / PAI fitted stand (cont.)

➤ Step 2: order any technical services

(extra power supply, telephone lines, parking, audio-visual equipment, etc.)

The SIAL fitted stand advisor will confirm all additional services required to organize your stand:

Additional services to be ordered before stand is fitted:

- Additional furnishings, refrigeration, extra flowers,
- Audio-visual equipment, office equipment, etc.

Be sure to order in advance as stock is limited once fitting has begun.

- If you book additional services, they must be ordered as soon as possible and certainly before the fair, in order to guarantee the best possible variety of ranges, colour schemes, sizes, and delivery dates.
- On site, ordered services will be provided while stocks last.

Other additional services: Security, hosting, catering, handling.

See the **list of Partners** in the “**Practical Information**” section of your Exhibitor’s Area.

➤ Step 3: Health and Safety

The Health and Safety Notice must be completed in the Exhibitor’s Area under “**My Forms**”.

➤ Step 4: delivery of your stand on Wednesday 17th October 2014 at 9 am.

***For all stands with fresh products, remember to order a permanent 24h electricity supply, not included as standard.**

The PREMIUM stand















From 16 sqm to 40 sqm



Non-contractual picture

Fittings included with your stand

➔ Carpet and modular melamine partitions

FRAME	 WHITE	 TITANIUM	PVC	 GREY	
PARTITIONS	 WHITE	 TITANIUM	 BIRCH WOOD		
MOQUETTE	 GREY	 COCOA	 BRICK RED	 ROYAL BLUE	 TURQUOISE
	 ORANGE	 PISTACHIO	 BURGUNDY	 PURPLE	

- ➔ 2 sqm storage area (3 sqm for stands over 24 sqm) with 2 shelves, 1 coat rack and 1 triple socket
- ➔ 1 semi-glazed office for stand over 31 sqm (6 to 9 sqm according to the needed size)
- ➔ 1 stand sign with text (for each open side)
- ➔ Tower with logo on 2 sides
- ➔ 1 reception counter

The PREMIUM fitted stand (cont.)

- ➔ 3kW fused power supply (daytime only)*
- ➔ Lighting with 100W spotlights (1 per 3 sq.m)
- ➔ Tower lighting with 300W spotlights (1 per logo)
- ➔ Design Package: € 800 excl. VAT for stand < 25 sqm, € 1000 excl. VAT ≥ 25 sqm, available products included in the item catalogue (furniture, plants, video,...)
- ➔ Daily cleaning (including a final preparation cleaning the day before the opening)

How to set up your stand

➔ Step 1: checking the equipment included with your stand

A SIAL fitted stand advisor will contact you directly about your choice of colour scheme, the positioning of your storage and sign, your choice of furniture, and the various services included with your stand.

➔ Step 2: order any technical services

(extra power supply, telephone lines, parking, audiovisual equipment, etc.)

The SIAL fitted stand advisor will confirm all additional services required to organize your stand:

Additional services to be ordered before stand is fitted:

- Additional furnishings, refrigeration, extra flowers,
- Audio-visual equipment, office equipment, etc.

Be sure to order in advance as stock is limited once fitting has begun.

- If you book additional services, they must be ordered as soon as possible and certainly before the fair, in order to guarantee the best possible variety of ranges, colour schemes, sizes, and delivery dates.
- On site, ordered services will be provided while stocks last.

Other additional services: Security, hosting, catering, handling.

See the **list of Partners** in the “**Practical Information**” section of your Exhibitor’s Area.

➔ Step 3: Health and Safety

The Health and Safety Notice must be completed in the Exhibitor’s Area under “**My Forms**”.

➔ Step 4: delivery of your stand on Thursday 16th October 2014 at 2 pm.

***For all stands with fresh products, remember to order a permanent 24h electricity supply, not included as standard**













The PREMIUM + stand

From 16 sqm to 40 sqm



Non-contractual picture

Fittings included with your stand

- ➔ Carpet and Wooden partitions covered with brush cotton
- ➔
 - COTTON**
 -  WHITE
 -  GREY
 -  BEIGE
 - MOQUETTE**
 -  GREY
 -  COCOA
 -  BRICK RED
 -  ROYAL BLUE
 -  TURQUOISE
 -  ORANGE
 -  PISTACHIO
 -  BURGUNDY
 -  PURPLE
- ➔ 2 sqm storage area (3 sqm for stands over 24 sqm) with 2 shelves, 1 coat rack and 1 triple socket
- ➔ 1 semi-glazed office for stand over 31 sqm (6 to 9 sqm according to the needed size)
- ➔ 1 stand sign with text (for each open side)
- ➔ Booth signage: digitally printed suspended at 5 m.
- ➔ 1 reception counter
- ➔ 3kW fused power supply (daytime only)*
- ➔ Lighting with 100W spotlights (1 per 3 sq.m)
- ➔ Tower lighting with 300W spotlights (1 per logo)
- ➔ Design Package: € 800 excl. VAT for stand < 25 sqm, € 1000 excl. VAT above 25 sqm, available products included in the item catalogue (furniture, plants, video,...)
- ➔ Daily cleaning (including a final preparation cleaning the day before the opening)

How to set up your stand

➤ Step 1: checking the equipment included with your stand

A SIAL fitted stand advisor will contact you directly about your choice of colour scheme, the positioning of your storage and sign, your choice of furniture, and the various services included with your stand.

➤ Step 2: order any technical services

(extra power supply, telephone lines, parking, audiovisual equipment, etc.)

The SIAL fitted stand advisor will confirm all additional services required to organize your stand:

Additional services to be ordered before stand is fitted:

- Additional furnishings, refrigeration, extra flowers,
- Audio-visual equipment, office equipment, etc.

Be sure to order in advance as stock is limited once fitting has begun.

- If you book additional services, they must be ordered as soon as possible and certainly before the fair, in order to guarantee the best possible variety of ranges, colour schemes, sizes, and delivery dates.
- On site, ordered services will be provided while stocks last.

Other additional services: Security, hosting, catering, handling.

See the **list of Partners** in the “**Practical Information**” section of your Exhibitor’s Area.

➤ Step 3: Health and Safety

The Health and Safety Notice must be completed in the Exhibitor’s Area under “**My Forms**”.

➤ Step 4: delivery of your stand on Thursday 16th October 2014 at 2 pm.

***For all stands with fresh products, remember to order a permanent 24h electricity supply, not included as standard**

The Prestige stand

From 40 sqm



Non-contractual picture

Fittings included with your stand

- ➔ Wood melamine partitions (height: 2.50m) and carpet, colour of your choice within an existing range
- ➔ Storage cupboard (including 3 shelves and 1 coat rack)
- ➔ Counter-bar with one level of door less shelves
- ➔ Multipurpose exposition modules (2 m x 2.50m, with a depth of 0.40m) adapted to meet your requirements: glass shelves, display windows, digital printing inside the module
- ➔ 1 unit up to 59 sqm; 2 units up to 89 sqm, 3 units up to 119 sqm...
- ➔ Booth signage: digitally printed suspended and lighted double-sided visual,
- ➔ 1 stand sign with text, 1 digital printing by module and 4 sqm of printing décor on partitions
- ➔ Power supply and Lighting: 6kW fused power supply (daytime only), 6 stem-mounted 400W projectors for stand sign, 3 low-voltage spotlights per module, stand lighting by spotlights, 5 triple sockets
- ➔ Design Package: €1,200.00 excl. VAT
- ➔ Daily cleaning (including a final preparation cleaning the day before the opening)

How to set up your stand

➤ Step 1: checking the equipment included with your stand

A SIAL fitted stand advisor will contact you directly about your choice of colour scheme, the positioning of your storage and sign, your choice of furniture, and the various services included with your stand.

➤ Step 2: order any technical services

(extra power supply, telephone lines, parking, audiovisual equipment, etc.)

The SIAL fitted stand advisor will confirm all additional services required to organize your stand:

Additional services to be ordered before stand is fitted:

- Additional furnishings, refrigeration, extra flowers,
- Audio-visual equipment, office equipment, etc.

Be sure to order in advance as stock is limited once fitting has begun.

- If you book additional services, they must be ordered as soon as possible and certainly before the fair, in order to guarantee the best possible variety of ranges, colour schemes, sizes, and delivery dates.
- On site, ordered services will be provided while stocks last.

Other additional services: Security, hosting, catering, handling.

See the **list of Partners** in the “**Practical Information**” section of your Exhibitor’s Area.

➤ Step 3: Health and Safety

The Health and Safety Notice must be completed in the Exhibitor’s Area under “**My Forms**”.

➤ Step 4: delivery of your stand on Thursday 16th October 2014 at 8 am.

***For all stands with fresh products, remember to order a permanent 24h electricity supply, not included as standard.**

The Optimum stand

From 40 sqm

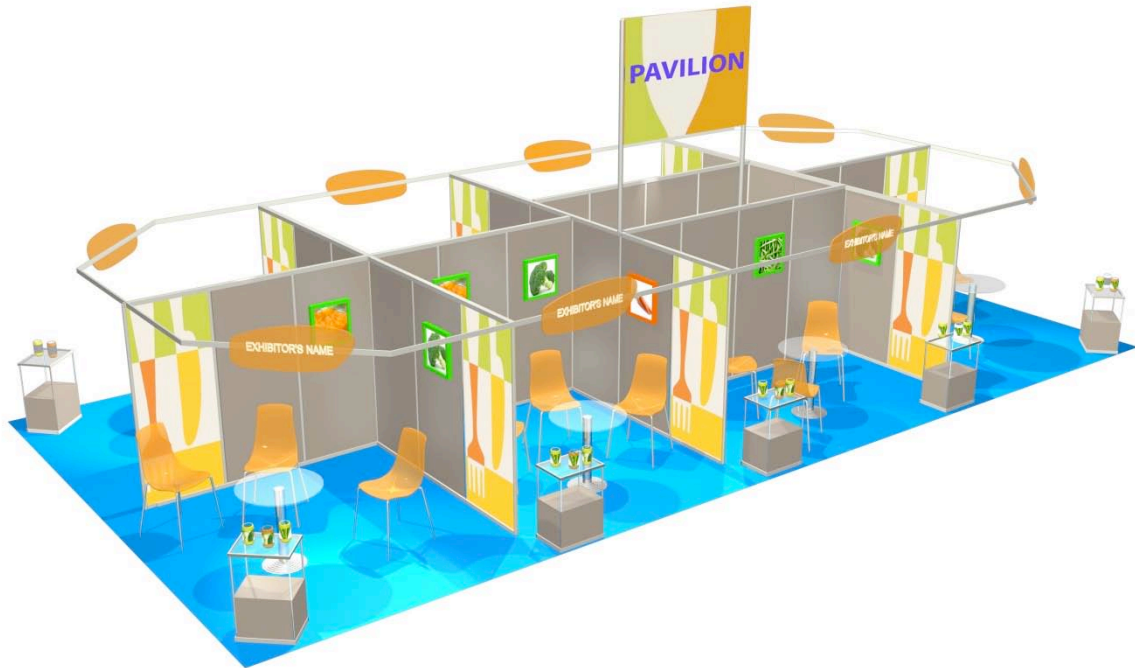

Sample of colours and fittings/Non-contractual picture

Fittings included with your stand

- ➔ Carpeting (choice of colour, patterned surround)
- ➔ Modular partitions and aluminium mesh frame (partitions: 5 choices of colours/aluminium frame: 2 colours) + 1 digitally printed decorative fascia on forex plastic for each exhibitor
- ➔ 1 semi-glazed reception counter and a 3m shelf on a stand per exhibitor
- ➔ Common storage cupboard including 3 shelves and a coat hook, 1 sink with 2 basins and connection to the water supply, 1 coffee machine with 300 servings
- ➔ Tower sign (h 4.80m) with logo (picture 3m x 2m) on 2 sides (4 sides from 200 sqm)
- ➔ 1 sign with wording per stand
- ➔ 1 collective power connection with power supply oh 1kW per 12 sqm (daytime only)* with cut-out switch and triple plugs
- ➔ Overall and individual lighting with 100W spotlights (1 per 3 sqm or rail of 3 for 9 sqm)
- ➔ Tower lighting with 300W spotlights (1 per logo)
- ➔ Design Package: € 2000 excl. VAT by edge of surface of 100 sqm
- ➔ Daily cleaning (including a final preparation cleaning the day before the opening)

How to set up your stand

➤ Step 1: checking the equipment included with your stand

A SIAL fitted stand advisor will contact you directly about your choice of colour scheme, the positioning of your storage and sign, your choice of furniture, and the various services included with your stand.

➤ Step 2: order any technical services

(extra power supply, telephone lines, parking, audio-visual equipment, etc.)

The SIAL fitted stand advisor will confirm all additional services required to organize your stand:

Additional services to be ordered before stand is fitted:

- Additional furnishings, refrigeration, extra flowers,
- Audio-visual equipment, office equipment, etc.

Be sure to order in advance as stock is limited once fitting has begun.

- If you book additional services, they must be ordered as soon as possible and certainly before the fair, in order to guarantee the best possible variety of ranges, colour schemes, sizes, and delivery dates.
- On site, ordered services will be provided while stocks last.

Other additional services: Security, hosting, catering, handling.

See the **list of Partners** in the “**Practical Information**” section of your Exhibitor’s Area.

➤ Step 3: Health and Safety

The Health and Safety Notice must be completed in the Exhibitor’s Area under “**My Forms**”.

➤ Step 4: delivery of your stand on Thursday 16th October 2014 at 8 am.

***For all stands with fresh products, remember to order a permanent 24h electricity supply, not included as standard.**

SIAL 2014

The Global Food Marketplace

Services



un événement
comeXposium
The place to be

Services

- Accommodation
- Aisle carpets
- Badges
- Cleaning
- Customs
- Electricity supply switch-on
- Exhibition Management Office
- Exhibitors' restaurants
- Food Donations
- Foreigners' Right to work in France
- Hostesses / Staff
- Hygiene and Health protection
- Inventory of your stand site
- Kitchen exhibition stands
- Promotion on stands
- Security Guards
- Stand design
- Supplementary and Theft Insurance
- Technical services (electricity, water, car parking, slings, telephone)
- VAT Refunds
- Waste and detritus removal

Accommodation

➤ Accommodation news

- A new agency has been selected to help you with your hotel bookings during the SIAL 2012. Whether you wish to stay in Paris or near the Exhibition Centre, the ATI agency will provide you with a wide range of options in 2*, 3* and 4* hotels at preferential rates.
- Feel free to specify any particular preferences you may have: you may wish, for example, to be on the line B of the RER train network, near the show's free shuttle buses or in a specific tourist district of Paris.
- Book online at www.sialparis.com/Useful-info/Hotel-reservation or by calling + 33(0)1 40 54 64 00 and enjoy the personalised service ATI will provide throughout your stay.
- Book as early as possible to have the best choice.

A.T.I.
8 rue de la Terrasse
75017 Paris - France
Tel.: +33 (0)1 40 54 64 00 - Fax: +33 (0)1 44 05 01 48
Email: sial2014@atibooking.com

Aisle carpets

Aisle carpet colour for all the halls



Noir
(Ref Expocolor : 0910 BLACK)

Badges

To enter the exhibition halls, all persons must carry a SIAL access badge (exhibitor or supplier badge) and must be wearing the appropriate safety equipment, particularly safety shoes. Otherwise, access to the Exhibition halls will be refused.

➤ Pedestrian access badge

- **Exhibitor's badge** allows access to the Exhibition centre during the assembly and dismantling periods and the exhibition itself, in accordance with the exhibitors' timetable.
Exhibitors can declare and personalise their badges in the Exhibitors' area at www.sialparis.fr

Services (cont.)

The number of badges provided is calculated automatically according to the surface area of the stand, to the value of one badge for 4 m².

Badges are sent via e-mail in the form of an e-badge.

Requests for additional badges, an order is available in your Exhibitors' area at www.sialparis.fr.

- **Suppliers' badges** allow access to exhibition halls during the assembly and dismantling periods. Badges are not valid during the exhibition opening period, from Sunday 19 October at 9.30 am to Thursday 23 October at 5.00 pm
Badges must be worn at all times.

Exhibitors can declare their sub-contractors and personalise their badges in the Exhibitors' area at www.sialparis.fr.

The number of badges provided is calculated automatically according to the surface area of the stand.

➔ **Badges will be sent after:**

- full payment of the balance due for your stand rental,
- receipt of the signed Safety, Hygiene and Safety Protection Document by the Cabinet

D.Ö.T.
81, rue de Paris
92100 BOULOGNE - France

- and the stand fitting application by the SIAL Stand Design office

DECOPLUS
1 rue Paul Delaroche – 75116 Paris – France
Tel.: + 33 (0)1 47 63 94 84 – Fax: +33 (0)1 43 80 59 63
E-mail: sialarchi@free.fr

Cleaning

Daily cleaning is included in your stand hire (excluding glass cabinets, partitions and washing).

Thorough cleaning of your stand and glass cabinets is essential to display your products to their best advantage to customers. The SIAL guarantees the quality of this service.

Please note:

- **If you have booked a bare stand**, you have automatically booked a daily cleaning service for your stand (excluding glass cabinets, partitions and washing) when you booked your SIAL 2014 stand.
- **If you have booked a fitted stand**, daily cleaning of your stand is included (with final preparation cleaning of partitions and glass cabinets the day before opening).

➔ **Services included in the daily cleaning of your stand**

Daily cleaning with vacuuming includes: vacuuming the floor including on upper levels, emptying of ashtrays and waste paper bins, wiping furniture and furnishing objects within reach, collecting and removing production waste.

Excluded from this service are: The cleaning of partitions and signs, cleaning exhibited machines and materials, cleaning glass and display cabinets, the provision of skips, the removal of carpets and glue at the end of the exhibition (unless your carpet was ordered from the SIAL).

➔ **Optional services**

- **Final preparation cleaning the day before opening.** This service includes the removal of empty packaging and waste, the cleaning of partitions, glass cabinets and provision of bin liners.
€ 4.40 excl VAT / m² for stands of less than 300 sqm, for larger stands, per sqm is € 3.3 excl VAT.
- **Daily floor mopping** (excluding glass cabinets and partitions)
€ 1.50 excl VAT / sqm

Order your supplementary services in the Exhibitors' area at www.sialparis.fr

Customs

↻ Customs service

Infos Douanes Services : +33 1 72 40 78 50
www.douane.gouv.fr

- Economic Regimes office
- Indirect Contributions office
- Open: Every day except Saturday and Sunday
- Times: 9:00 am to 5:00 pm.

↻ Customs clearance for goods originating in non-EU Member States

During the SIAL trade show, the Parc des Expositions de Paris-Nord Villepinte site falls under the temporary admission regime under surveillance by customs.

Temporary admission begins on the day the materials arrive within the exhibition hall and end thirty days after the exhibition closes.

Imported goods must be cleared by the Customs Service before being placed on the Exhibitor's stand.

↻ Ordinary law standard regime



Merchandise arrival:

Merchandise must be presented to the Customs Office, under cover of one of the following documents:

a) TIR Carnet (international carriage of goods by road)

For vehicles arriving directly from abroad, where such merchandise was verified and sealed by the originating country's customs service.

N.B.: Transporters travelling under cover of a TIR Carnet taking on various merchandise including only a portion destined to an event, must take all steps to ensure that the Paris Expositions office is the last unloading station. Consequently, when arriving at the office, TIR vehicles must contain only merchandise destined for exhibition at the event.

No waivers shall be granted.

b) Declaration for Transit

Made in a land, sea, or airport border office when the merchandise entered.

c) Waybill

d) Transit Document

Items to be provided with a, b, c and d documents:

- Truck waybill (only with TIR Carnet): Number 3
- Detailed content of each package (gross and net weight) established by the shipper: Number 5
- Pro forma invoice in French indicating unit values: Number 6
- Descriptive leaflets for machines: Number 2



Temporary admission status:

(Third-party country merchandise)

Under no circumstances shall the documents listed above replace a temporary admission declaration.

Upon arrival at the Exhibition Customs Office, merchandise must be immediately declared for temporary admission through a customs shipping agent

After registration, verification and sealing of the goods, the documents concerned authorise their transport:

Only after accomplishing these formalities may they be directed towards the exhibitor's stand.

During the event, the merchandise must be presented on the stand for any Customs inquiries.

➔ **Outgoing goods:**

At the end of the event, no foreign merchandise may leave the Exhibition without first submitting one of the various declarations listed below through a shipping agent to the Customs Office, which after recording, verification, and sealing the merchandise, covers their transportation:

a) For re-exportation:

The following documents must be presented for the exit visa: EX 3 and T1 declarations.

b) For transit:

To a customs warehouse where the merchandise is to be placed under customs surveillance: T1 declaration.

c) For temporary admission of goods for purposes of testing and experimentation, as the case may be:

EU4 or IM4 declarations, as the case may be.

Foreign merchandise benefiting from a temporary admission grace period to remain on continental French territory for consumption in Embassies must be declared to Customs to pay applicable taxes and fees.

Only the aforementioned documents enable the Customs Service to clear temporary admission status. In cases of non-clearance (partial or total) of temporary admission, legal steps may be taken against the exhibitors or shipping agents guilty of removing merchandise under customs.

➔ **The ATA carnet system for exhibitions**

(Except for foodstuffs)

ATA Carnet, even reported at Community borders must be presented to Parc des Expositions Customs. It can be used for goods to be exhibited or used at an Exhibition.

This international document has the advantage of being used instead of national documents.

Indeed, transit transportation from the border office to the relevant office may be performed under cover of an ATA Carnet transit certificate.

Upon arrival at their destination, the Customs Service clears the transit certificate and accepts the goods under an entry certificate.

At the end of the event, re-export of the goods abroad is covered by a second transit certificate. So it is necessary to undertake the usual warehouse entry and re-exportation declarations, but to be validly used on French Customs territory, the ATA Carnet must include:

- 1 import certificate,
- 1 re-export certificate,
- 2 transit certificates for re-export (1 stays with the Exhibition office, 1 serves as an accompanying document).

Note that the re-exportation deadline is set, in principle, one month after the event closes, without exceeding the Carnet's expiration. This deadline will be specified by the Customs Service on the entry certificate and its counterfoil.

Moreover, leaving the goods behind is not strictly excluded since goods sold for the domestic market may, after being declared on form COM5, IM4, or EU4 and after being presented to customs, be released to the market under the same conditions as if they were covered by national documents.

Electricity supply switch-on

The electricity supply will be switched on from Wednesday 15 October 2014 at 7:30 am to Thursday 23 October 2014 at 7.30 pm (hall 8 only: Thursday 16 October 2014 from 2.00 pm).

Please note: Frozen or refrigerated products require a 24-hour electricity supply.

Exhibition Management Office

**The on site Exhibition Management Offices,
multiple offices for a better service.**

Opening:

Services (cont.)

Opening days: from Tuesday 14th October to Saturday 25th October 2014

Hours :
from 14th to 16th October : 8:00 am – 7:30 pm
from 17th to 18th October : 8:00 am – 10:00 pm
from 19th to 22nd October : 9:00 am – 7:00 pm
the 23th October : 9:00 am – 10:00 pm
from 24th to 25th October : 8:00 am – 7:30 pm

📍 **Location :**

Mezzanine hall 3 : For the exhibitors of the halls 1/2/3/4/8

Hall 5a : For the exhibitors of the halls 5a/6

Hall 5b : For the exhibitors of the hall 5b

Hall 7 : For the exhibitors of the hall 7

Exhibitors' restaurants

The SIAL 2014 and the Exhibition Centre restaurants have developed a new and improved range of restaurant options to meet the expectations of both visitors and exhibitors:

- **new companies** have joined the exhibition centre: Hippopotamus, Oliviers & Co, Lecointre Paris, Fauchon, Manhattan hotdog...
- **the range of take-away food is increasing**, offering a wider variety of products: sushi, vegetarian options, organic food, Mediterranean menus, club sandwiches, etc.
- In order to guarantee optimum levels of service during the SIAL 2014, the terrace areas will have more seating and menus and product information will be available in several languages.

For deliveries to stands, see the list of suppliers in the Exhibitors' area at www.sialparis.fr.

Catering services:

Organisers and Exhibitors are free to choose the Caterers they wish. However, caterers are not free to access the Exhibition Centre and must complete a one-off site service agreement based on a fee of 8% of the overall turnover of services provided at the centre (catering, equipment and staff) and obtain the Vehicle Passes in this way. HORETO and ELIOR also provide "catering" services and are subject to the same contractual conditions regarding the fee.

Viparis CATERING Contact:

Ms Myriam Mottin, Viparis Service Concession Assistant
Tel.: 01 40 68 14 46 – email: myriam.mottin@viparis.com

HORETO CATERING Contact:

Ms Marie-Pierre Lane, HORETO Sales Representative
Tel.: 01 58 88 38 26
email: mp.lane@horeto.com

ELIOR CATERING Contact:

Ms Emmanuelle Thiault, ELIOR Sales Representative
Tel.: 01 48 63 32 00
Email: emmanuelle.thiault@elior.com

Food Donations

SIAL, in partnership with SOLAAL* and affiliated association the French Red Cross, carries out a collection of the food products which are not taken away by exhibitors.

If you wish to donate your products, make this known via your Exhibitors space online at www.sialparis.fr under the "My forms" heading.

The products will be collected directly from your stand on Thursday 23rd October from 5pm.

*Solidarité des producteurs Agricoles et des Filières Alimentaires (Solidarity of Agricultural Producers and the Food Industry).

Foreigners' Right to Work in France

➤ **The regulations regarding foreigners' right to work in France requires reporting those people working on your stand to the URSSAF** [Social Security Contribution Collection Office]. This applies in the case below, for which a statement should be completed and returned **before August 29th, 2014** to the indicated address:

- Affidavit if you use a service provider working in France and domiciled or residing abroad
- Secondment Statement (a service provider using foreign labour in France)
- Work Permit for a secondment lasting less than three months for foreign employees

These forms are available in PDF format in your Exhibitor area on www.sialparis.fr

Hostesses / Staff

- To welcome current and potential customers to your stand, to guide you around the Paris-Nord Villepinte exhibition centre, to be in constant contact with on-site organisational staff to meet your every need... The SIAL offers a full range of services: hostesses, interpreters, handlers, etc.
- See our list of suppliers in the Exhibitors' area of www.sialparis.fr

Hygiene and Health protection

➤ **The Hygiene and Health Protection Document (PPSPS: Specific Safety and Health Risk Prevention Plan)**

- Any person wishing to enter the halls should carry a SIAL access badge (exhibitor or supplier badge) and must be wearing the appropriate safety equipment, particularly safety shoes. Otherwise, access to the Exhibition halls will be refused.
- The Hygiene, Safety and Health Protection document should be completed online in the Exhibitors area, printed, signed and returned to the Cabinet DOT at the latest by 12th September 2014. Copies should be distributed to all of your suppliers and sub-contractors.
- Access to the exhibition halls will not be authorised without a valid document.

Inventory of your stand site

When assembly and dismantling are finished and the stand site completely cleared (including waste and detritus), the SIAL Exhibition Management Office will, at the request of the exhibitor or their decorator, issue a **stand site clearance certificate**. This certificate releases the exhibitor from all responsibility in the event of damage to the area or services hired after their departure.

The certificate must be issued by 2.00 pm on Sunday 26 October at the latest (except for hall 8: 25 October at 2.00 pm)

Kitchen exhibition stands

You will find the declaration form at www.sialparis.fr in your Exhibitors Area > My forms

In all kitchens:

- The floor (or the table) supporting cooking appliances must be made of non-combustible material or covered with M0-class material
- Cooking appliances must be kept at a suitable distance from any combustible material and installed in such a way as to prevent any danger of fire
- If such devices are located near a partition, M0 surfacing must be provided up to a height of 1 metre to the right of the device
- Electric meters must be positioned at least 1 metre from any water outlet

- Every installation must be equipped with 1 or more extinguishers.
- **Cooking and heating appliances with a normal power rating of less than 20 kW are permitted inside exhibition halls. However, please respect the following conditions:**
 - filters must be placed above cooking appliances;
 - cooking and heating appliances must not pose any risk to the public;
 - appropriate safety measures must be in place (extinguishers)
- **Cooking and heating appliances with a normal power rating greater than 20 kW for the whole stand are permitted inside exhibition halls. However, please respect the following conditions:**
 - inner and outer walls must have a fire-resistance rating of 1 hour (French regulations)
 - doors opening onto the stand should be PF 1/2 hour or E 30 (door mandatory)
 - a distance of 4 metres must be maintained between each kitchen unit
 - flame-retardant screens must be placed around cooking appliances
 - if opening onto the stand:
 - possess a fixed vertical screen that is fire stable in 1/4 hour or E 1S-S and in a material with a fire classification of M1 or A2-S1, d1 and be of a minimum height of 0.5m underneath the finished kitchen ceiling.
 - include a cooker hood and ventilation duct in MO or A0-S1, dO material, the extractor fan should function for 1 hour with smoke at 400°C
 - the main fuse box should be fitted with an emergency cut-out switch
 - cooking or reheating appliances should have the CE label
 - emergency equipment should be to hand (appropriate extinguishers)
 - Cooking and reheating appliances that give off water vapour can be used without a filter, but other appliances that emit other substances (grease, etc.) must have an overhead hood filter, **and all combustion equipment (gas) must have an outside outlet for exhaust.**

PKL-style portable container kitchens are permitted if they use extraction systems.

Promotion on stands

The SIAL has established some norms to ensure the smooth running of the exhibition and an optimum visitor experience. Exhibitors may promote their stands as they wish provided they adhere to the conditions below and respect the exhibitors' timetable.

➔ Non-authorised activities:

- The distribution or placing of leaflets in the exhibition aisles, at the entrance, on the esplanade or close to the station,
- Promotion in the aisles (with robots, hostesses, sandwich boards, etc.),
- Offering tastings on the edges of the aisles or in the aisles themselves. These are permitted within the stands,
- Musical promotion,
- Video walls must be set back a minimum of 2m from the edges of the aisle.

Events arranged without the authorisation of the Exhibition Management Office are prohibited at the exhibition.

Security Guards

Choosing a good firm of security guards to protect your stand is important to ensure a high quality service suited to your needs. See the SIAL's tailored solutions in the Exhibitors area at www.sialparis.fr

Please note:

In the event of an inspection by the works inspectorate, the company used must be able to present employment contracts and URSSAF certificates. Remember to ask your supplier for these documents, as you will be held responsible.

Stand design

The SIAL 2014 stand design regulations include the norms of stand presentation and fitting. These norms also include all current safety regulations applicable to shows, fairs and exhibitions.

➔ your stand fitting application

Each stand plan should be submitted by **4 July 2014** at the latest to the SIAL Stand Design office:

DECOPLUS
1 rue Paul Delaroche – 75116 Paris – France
Tel.: + 33 (0)1 47 63 94 84 – Fax: +33 (0)1 43 80 59 63
E-mail: sialarchi@free.fr

and include the following documents:

- The Installation File for your stand, completed and signed
- The Stand Project: «Overhead view» plans showing scales, dimensions and positions of perimeters (shared partitions + alleys)
- «Cutaway» plans showing scales, dimensions and heights of volumes depicted

The stand fitting application will be sent to you via e-mail by the SIAL's Stand Design office as soon as you have chosen your stand site. It should be printed, signed and returned to the SIAL with all the necessary documents.

Exhibition access badges will be dispatched when the fitting application is complete. Otherwise, access to the Exhibition halls will be refused.

Supplementary and Theft Insurance

➔ Additional Insurance

The SIAL offers exhibitors the option of taking out supplementary insurance to cover the real value of the goods exhibited on their stand.

- If the value of their goods exceeds the sum guaranteed by the SIAL, i.e. € 500 per sqm with a minimum of € 6,000 and a maximum of € 400.000, the exhibitor may take out a supplementary policy for the difference between the value of goods as valued by him and the sum already covered by the SIAL.
For the extra declared value, the insurance premium including tax and costs will be calculated at a rate of 0.27%.
- **For insurance cover provided by the SIAL, see the insurance regulations in the exhibitors' area of our website, www.sialparis.fr**

➔ Theft insurance

Theft insurance enables you to insure the full value of your stand (excluding food products, beverages, etc) against the risk of theft, with an excess of € 315 per incident.

For the extra declared value, the insurance premium including tax and costs will be calculated at a rate of 0.63%.

- **Order theft insurance in the Exhibitors' area of our website, www.sialparis.fr**

➔ Plasma Screen Insurance

Plasma Screen Insurance is a policy covering specific damage to plasma screens that are fixed or firmly cabled to the stand structure. This policy will take effect on the first morning of the exhibition's opening to the

Services (cont.)

public (exhibition opening time) to the time the exhibition closes to the public. The premium will be 4% incl. tax of the value of the equipment, with a minimum of € 250 per screen covered.

Losses

The goods and materials policies will expire on Thursday 23 October 2014 at 5.00 pm.

No loss can be covered if it is not declared to the SIAL within 24 hours and, at the latest, by Friday 24 October 2014 at 5.00 pm. Thefts that are not covered by the SIAL but insured by the exhibitor themselves should be the subject of a statement made to the police within the required time limit:

Technical services (Electricity, Water, Car Parking, Slings, Telephone, Internet, etc.)

Place all your orders, including for services from the Paris Nord Villepinte exhibition centre in the Exhibitors' area of the website www.sialparis.fr

VAT Refunds

Since the entering into force of the VAT package on January 1st, 2011 concerning trade show services, the applicable VAT rules have been changed. Nevertheless the French Tax Authorities consider (instruction 3 A-2-11 of March 28th, 2011) that space rental during a trade show is a land related service and therefore taxable in France.

Thus, certain services, including services supplied by the organizer of the trade show, are still invoiced **with French VAT**: rental of non-equipped spaces, participation/admission fees, parking, technical services (electricity, stand cleaning...), catering, restaurant expenses...

Foreign companies, based in or outside the European Union and **which are taxable persons**, may under certain conditions obtain the refund of the VAT.

VAT is refunded on all kind of expenses except on the following: accommodation (hotel, apartment rental) for employees of your company and transport of persons (taxi, car rental, petrol, train, plane).

TEVEA International

29-31, rue Saint-Augustin – 75002 PARIS – France
Tél. : +33 (0)1 42 24 96 96 – Fax : +33 (0)1 42 24 89 23
E-mail : mail@tevea.com

➔ Simplified procedure:

TEVEA International, in cooperation with SIAL, offers a simplified procedure which is safe and fast for your company. To benefit from this simplification, please complete, sign and return to TEVEA International the form available in the Exhibitors' area at www.sialparis.fr.

PLEASE NOTE

Only original invoices are accepted by the tax authorities for VAT refunds, so keep them in a safe place. If they are lost, no VAT will be refundable.

No copies, duplicates or certified copies will be accepted by the French tax authorities.

It is also forbidden to issue a second original copy of an invoice.

Waste and detritus removal

Exhibitors or their decorators are responsible for managing the waste generated during stand assembly and dismantling. Exhibitors must make every effort to ensure these operations are carried out. Failing this, and in the event of any damage occurring as a result, a penalty fine for waste will be imposed on the exhibitor:

➔ Sum of the penalty:

- surface area < up to 50 sqm € 1500 excl. tax
- surface area 50 to 100 sqm € 3500 excl. tax
- surface area 100 to 250 sqm € 5000 excl. tax
- surface area 250 to 400 sqm € 7000 excl. tax

Services (cont.)

- surface area > up to 400 sqm € 10,000 excl. tax

PLEASE NOTE

To avoid any dispute over the clearance of your stand site, a **stand site clearance certificate** can be issued at the exhibitor's request by the Exhibition Management Office, at the latest by Sunday 26 October at 2.00 pm (except Hall 8: Saturday 25 October 2014 at 2.00 pm).

SIAL 2014

The Global Food Marketplace

Regulations



an event by
comeXPOSIUM
The place to be

Standard Terms and Conditions of Exhibition

Floor space and stand equipment

1. APPLICATION AND ACCEPTANCE OF THE STANDARD TERMS AND CONDITIONS FOR THE LETTING OF EXHIBITION FLOOR SPACE AND STAND EQUIPMENT

exhibitors (hereinafter referred to as the "Exhibitors") who make a request for admission to the SIAL exhibition (hereinafter referred to as the "Exhibition") organised by SIAL, SA with a board of directors, board of trustees and capital of 640,000€ whose registered head office is at 70 avenue du Général de Gaulle, 92058 La Défense Paris Cedex and registered in the Nanterre trade and company register under number 692 029 788 (hereinafter referred to as the "Organiser") at the exhibition centre Paris-Nord Villepinte (hereinafter referred to as the "Site").

When applying to reserve a stand, the Exhibitor undertakes to read the Terms and Conditions, the Exhibitor's Guide, the Standard Regulations for Commercial Events and, where available, any specific Regulations of the Exhibition.

The Exhibitor shall be deemed to have accepted the Terms and Conditions as well as any other documents to which they refer, and the Exhibitor thereby agrees to waive reliance upon any alternative and/or contradictory documentation, in particular its own standard terms and conditions of purchase, upon admission to the Exhibition. Any reservations or modifications made by the Exhibitor in whatsoever manner to the Terms and Conditions or any other documents to which they refer shall be deemed null and void.

Furthermore, it is expressly agreed that under no circumstances shall admission to the Exhibition oblige the Organiser to admit the Exhibitor to any future Exhibitions or any other events organised by the COMEXPOSIUM group to which the Organiser belongs and shall not confer upon the Exhibitor any booking rights or priorities in respect thereof.

2. ADMISSION

duly authorised to validate the reservation application. During this initial review, the following matters (this list is intended to be indicative and not exhaustive) shall be taken into account:

- the creditworthiness of the applicant,
- the compatibility of the applicant's activities with the nomenclature of the Exhibition,
- the match between the products or services offered by the applicant and the positioning of the Exhibition,
- the neutrality of message that the applicant could deliver at the Exhibition. All proselytising and/or militarism that could interfere with the smooth running of the Exhibition is strictly prohibited.

Any stand reservation applications received from Exhibitors that are a debtor of, and/or party to, any dispute or litigation with the Organiser or a company within the COMEXPOSIUM group shall be refused.

Except in the event where the Organiser, within one month of receipt in writing of an Exhibitor's stand reservation application, rejects an Exhibitor's application and refuses admission, submission of a signed application form shall be deemed to be final and irrevocable and shall oblige the Exhibitor to pay in full all amounts due in respect of its participation as Exhibitor and/or its request for an equipped stand.

In the event that an Exhibitor submits a stand reservation application online via the Exhibition website, the Exhibitor shall be fully and irrevocably liable for payment in full of all amounts due in respect of its participation as Exhibitor

and/or its request for an equipped stand upon receipt of written confirmation of participation in the relevant Exhibition, which (except where an application is refused) shall be sent by email by the Organiser within one (1) month of the online validation of the stand reservation application.

The Organiser reserves the right to accept or reject stand reservation applications at its discretion and the Organiser shall not be held liable for any damage or interest in respect thereof.

The Organiser reserves the right to reject any stand reservation applications received or validated online after the application deadline has passed (the postmark shall serve as proof of date for stand reservation application forms sent by post). After this date has passed, the Organiser shall not guarantee the availability of any equipped stands.

3. METHODS OF INVOICING

All prices indicated on the Organiser's documentation or on the Exhibition website are expressed in euros exclusive of taxes. In accordance with legislative and regulatory requirements the prices shall be increased at the point of sale to include the addition of Value Added Tax at the rate applicable at that time.

4. METHODS OF PAYMENT

Payment of amounts due under the Terms and Conditions or any other agreement entered into shall be made as they fall due and in the following manner:

- the first instalment: shall be paid at the time that the registration application form is sent by post or submitted and validated online, by cheque or direct funds transfer or, in the event that the reservation application is submitted online, by debit card. In the event that the Organiser should refuse the application, it is hereby expressly agreed that applicant shall be reimbursed for this amount.
- outstanding participation fee: shall be paid no later than fifteen (15) days after the date of issue of the balancing invoice, by cheque or direct funds transfer. No discounts are available for early payment or payments on account.

All registrations made within thirty (30) days of the start of the Exhibition shall be accompanied by payment in full of the Exhibition participation fees and/or the costs of any equipped stands requested.

All requests for an equipped stand submitted after registration shall be payable in full at the time of request.

All amounts should be made payable to the Organiser and must be in euros.

5. SECURE PAYMENT AND PROOF OF TRANSACTION IN THE EVENT OF AN ONLINE APPLICATION

The Exhibition website uses a secure payments system and the Organiser has adopted the ATOS SSL encryption procedure, which encodes and protects confidential information.

Unless proven otherwise, data recorded by the Organiser shall constitute proof of all dealings between the Organiser and the Exhibitor.

Data recorded by the payment system shall constitute proof of any financial transactions.

6. LATE PAYMENT OR FAILURE TO PAY

Any amounts that remain outstanding upon expiry of the payment date set out on the invoice, whether or not that date is the same as that which is set out on the registration form or in the summary of the online reservation application, shall give rise to the application of late payment interest rates equal to three times the statutory interest rate in effect and starting from the day following the payment date set out on the invoice.

In the event of non-compliance with the payment deadlines set out in clause 4 "Methods of Payment" above, a flat-rate indemnity of €40 in respect of recovery fees shall be required by the Organiser in addition to any late payment penalties referred to above. It is hereby expressly agreed that this flat-rate indemnity shall not preclude any other fees incurred by the Organiser in recovering unpaid invoices.

Stands shall only be made available to Exhibitors once full payment has been made.

Once a stand has been allocated to an Exhibitor, the balance must be paid on or before the date indicated on the invoice.

In the event that the balance remains outstanding after the payment date, the Organiser reserves the right to make the allocated space available to another applicant and/or to prohibit the Exhibitor from occupying that space; that notwithstanding, the Exhibitor shall remain liable to pay the outstanding balance to the Organiser.

7. VAT

Exhibitors from outside France have the option to obtain a V.A.T. refund as follows:

***For countries that are members of the European Union:**

- Submit the refund request via the appropriate online State portal where the Exhibitor is registered in accordance with the provisions of Directive 2008/9/CE of 12 February 2006. In France, this is the fiscal portal at www.impot.gouv.fr.

- A digital copy of the original invoices for all sums over €1,000 must be attached and submitted with the online refund request.

- The refund request must be submitted on or before 30 September of the calendar year that follows the refund period.

***For countries outside the European Union:**

The Exhibitors concerned must without fail appoint a tax representative in France to carry out this and any other tax formalities.

8. WITHDRAWAL

The Exhibitor shall notify the Organiser in writing of any cancellation.

In the event that the Exhibitor partially (by reducing the surface of its stand area) or fully cancels its participation in the Exhibition and/or its request for an equipped stand, on any date and for whatsoever reason, the Exhibitor shall nonetheless remain liable for the payment of all outstanding amounts due in respect of its participation and/or stand. Furthermore, any amounts already paid in respect of rent for a stand area and/or a request for an equipped stand, shall be retained by the Organiser and the Exhibitor shall remain liable for the payment of any outstanding amounts, which shall fall due forthwith irrespective of the dates set out on any invoice or registration form, whether or not the reserved stand is allocated to another Exhibitor.

Moreover, the Exhibitor shall pay compensation to the Organiser of an amount equivalent to 15% of its order in respect of its attendance at the Exhibition and/or its request for an equipped stand.

It is hereby expressly agreed that in the event that an Exhibitor has not occupied their allocated stand area twenty-four (24) hours before the opening of the Exhibition,

the Exhibitor shall be deemed to have cancelled its participation in the Exhibition and the aforementioned provisions shall apply.

9. INSURANCE

9.1. Exhibitor's property and civil liabilities

The Organiser is not liable for any damages or losses caused by an Exhibitor to a third party, or any damage suffered by the Exhibitor's property.

Consequently, the Exhibitor undertakes to subscribe to the necessary insurance policies that cover its actions during the Exhibition.

The Exhibitor undertakes in particular to subscribe to, prior to the Exhibition set-up date, and with insurance companies that are certified to provide insurance in France, insurance policies covering:

> Financial consequences of any liability claims for any bodily injury, material damage and consequential financial loss caused to third parties, including to the Site Manager and Site Owner, due to its activities during its participation in the Exhibition (including during the set-up and break-down phases).

> Financial consequences of any civil liability claims for property losses at the Site, whether they are consequential or not, caused to the Site Manager and/or Site Owner, during the Exhibitor's occupation of the Site. Tenant risk insurance must be obtained for minimum damage cover of €3,000,000.

> Damages or losses caused to property owned by the Exhibitor or placed in its care.

Given this, the Organiser offers a loss and damage insurance policy the Exhibitor can take, subscribed to by Comexposium Assurances, under the specific conditions stated in sub-clause 9.3 below.

The Exhibitor must provide proof of its subscription to such insurance policies by sending a copy of the insurance certificate to the Organiser within thirty (30) days of signing the participation file or receiving online validation of the stand reservation application.

If the Exhibitor does not provide proof of its property damage insurance policy, the automatic insurance cover offered in the participation file or the online stand reservation application will be automatically invoiced to the Exhibitor by the Organiser in order to meet the requirements of the site manager company.

9.2 insurance offered by the organiser:

a) Automatic insurance

The Organiser offers Exhibitors the option of taking out insurance cover subscribed to by Comexposium Assurances on behalf of its Exhibitors. This insurance policy covers any damage to property held by Exhibitors who have subscribed to it by accepting the proposed insurance in the participation file. The amount of cover is specified in the Insurance Regulations appended to the participation file and is also accessible on the Exhibition website, subject to any changes to the insurance conditions.

By taking the proposed insurance, as detailed in the appended Insurance Regulations, the Exhibitor is taking cover with Comexposium Assurances, who is the policy subscriber.

b) Additional insurance cover for the Exhibitor's property:

The Exhibitor may submit a request to the Organiser to subscribe to insurance for:

> Property damage or losses: additional insurance on top of the amounts covered by the principal policy upon payment of a premium calculated from the additional capital value.

➤ Plasma screens: a specific insurance policy must be subscribed to.

9.3. Waiver of recourse

a) Against the Site Manager and/or Site Owner companies:

By executing the commitments undertaken by the Organiser towards the Site Manager and/or Site Owner companies, the Exhibitor, by the mere fact of its participation, declares that it waives all recourse that it or its insurers may be entitled to make against these companies and their respective insurers, for any direct or indirect losses the latter parties may cause to its property, equipment or fittings as well as any caused to that of its agents, as well as for any operating losses and/or extra costs regardless of the cause, with the exception of malicious acts.

In addition, the Exhibitor declares it waives all recourse against the Site Manager and/or Site Owner companies and their respective insurers in the case of one of the following events occurring, with harm caused to the Exhibitor:

➤ In the event of fire damage, theft, water damage, humidity or any other situation affecting the Exhibitor's own property, it must insure itself against these risks.

➤ In the event of abnormal actions by other Site occupants, their staff or suppliers, or visitors.

➤ In the event of interruption or inadvertent functioning of the water, gas or electricity supply, the air conditioning or other general systems, and the suspension or shut-down, even for an extended period, for a reason outside the control of the Site Manager and/or Site Owner companies of fluid systems including the automatic fire extinguisher network, heating and air conditioning systems, or any of the equipment items shared by the Site.

➤ In the event of contamination of the heating, water or air conditioning networks for a reason outside the control of the Site Manager and/or Site Owner companies.

➤ In the event of security measures taken by the Site Manager and/or Site Owner companies and/or by any government authority, should these cause harm to the Exhibitor.

The Exhibitor undertakes to obtain the same waiver from its insurers.

b) Against the Organiser:

The Exhibitor also declares it waives all recourse that it or its insurers may be entitled to make against the Organiser and its insurers in regard to direct or indirect damage that its property, equipment and fittings may suffer as well as that of its agents, as well as for any operating losses and/or extra costs regardless of the cause, with the exception of malicious acts.

The Exhibitor undertakes to obtain the same waiver from its insurers.

It is further specified that, on the basis of reciprocity and exception made of malicious acts, the Organiser and its insurer waive any claim against the Exhibitor and its insurer for damage affecting any property, equipment and fittings belonging to the Organiser and for which the Exhibitor is responsible. It is further specified that this waiver is not applicable for any loss or damage that may affect the Site's buildings, fittings and equipment owned by the Site Manager and/or Site Owner companies and that has been given into the care of the Exhibitor.

10. ALLOCATION OF STANDS

The Organiser shall draw up an Exhibition floor plan and shall allocate stand areas as applications are received and taking into account the different sectors of the event. The Organiser shall use their best endeavours to take into account the wishes of the Exhibitors and the nature of the products exhibited. So as to be able to do this, and taking into account the inherent constraints imposed in the placement of Exhibitors, the Organiser reserves the right to

modify the surface area requested by the Exhibitor, up to a maximum of 20%, and to modify the corresponding invoice accordingly. Such modifications shall not give rise to any right for the Exhibitor to cancel its participation in the Exhibition. It is hereby expressly agreed that the Organiser shall have exclusive discretion to determine the allocation of stand areas.

Participation by an Exhibitor in any previous events shall not confer upon the Exhibitor the right to be allocated any particular stand area(s).

Any complaints made by an Exhibitor in respect of the allocation of stand areas should be addressed in writing to the Organiser no later than seven (7) days from receipt of the Exhibition floor plan. Any such complaints must be supported by documentation that clearly sets out the serious nature of, and/or the reasons for, the complaint.

Where the Exhibitor complies with the provisions set out in the present clause, the Organiser shall use its best endeavours to meet a request to change an allocated stand area.

Where the Exhibitor has not referred back to the Organiser upon expiration of the seven (7) day period starting from receipt of the floor plan, it shall be deemed to have accepted the stand area allocated to it.

Under no circumstances whatsoever shall the Organiser be held liable for any consequences arising from the placement of a stand area allocated to an Exhibitor.

11. SUBLETTING / SHARED EXHIBITING

Exhibitors may not provide any advertising services of any nature on any media for a company that is not itself an Exhibitor. Furthermore, the Exhibitor is prohibited from assigning or subletting any stand or part of any stand area that it has been allocated without prior written agreement from the Organiser. Where the Organiser agrees to the subletting by the Exhibitor of all or part of an allocated stand area, the Exhibitor shall pay the requisite registration fees for each of the companies present at the allocated stand area. The Exhibitor undertakes to ensure that any sub-lessee of its stand area shall comply with the Terms and Conditions. The Exhibitor hereby acknowledges that it shall be liable for any breach of the Terms and Conditions committed by any sub-lessee of its stand area. Moreover the Exhibitor hereby indemnifies the Organiser against any action, claim, charge, judgment and/or miscellaneous disbursements that may arise as a consequence of the presence of any company at its allocated stand area and/or their participation in the Exhibition.

12. STAND

Information regarding the installation and removal of stands is available in the Exhibitor's Guide.

a) Stand layout and decoration

- The presentation of products shall only be permitted inside the stand area and in a manner that does not encroach upon the pathways and so as not to interfere under any circumstances with neighbouring stands. In the event that the Exhibitor breaches the provisions of the present sub-clause the Organiser may remove the Exhibitor's products and/or materials and the Exhibitor shall bear any costs arising therefrom.
- The Exhibitor shall create an ambiance that properly reflects the products it is exhibiting and shall pay particular attention to the general decoration of its stand(s).
- All materials and products shall be displayed in an aesthetically pleasing manner.
- The use of stalls is strictly prohibited. Merchandise shall be kept in a storeroom.
- The Exhibitor shall comply with the maximum height regulations for the stands and brand signs as set by the Organiser (refer to the Exhibitor's Guide for further

details). No decoration on any stand shall exceed the height limits set out in the aforementioned regulations without the prior written agreement of the Organiser. Any breach of the provisions of the present sub-clause may result in the immediate disassembly of the Exhibitor's stand and the Exhibitor in breach shall bear any costs arising therefrom. Where the Exhibitor is allocated an island stand, it shall not construct supplementary partitions without obtaining prior written agreement from the Organiser.

The Exhibitor shall, within the timeframe set out by the Organiser, submit a draft layout of materials and equipment to the Organiser for approval.

Exhibitors are hereby expressly reminded that they must obtain approval from the Organiser, or a service provider duly appointed by the Organiser, for their layout plan.

b) Stand use - compliance with applicable laws and regulations

The Exhibitor undertakes to comply with any laws and regulations applicable to the carrying out of the activity(ies) and/or provision of the service(s) that it wishes to develop within the scope of its participation in the Exhibition. To this end, the Exhibitor undertakes to make any obligatory declaration(s) and to obtain any necessary approval and/or authorisation(s) (and in particular, in the event that it sells or gives away drinks to be consumed on the premises) and all in a manner such that under no circumstances shall the Organiser have cause to be concerned.

Furthermore, the Exhibitor undertakes not to cause any discomfort (noise, odour etc.) to neighbouring Exhibitors and not to interfere with or negatively impact the organisation of the Exhibition.

c) Degradations

Except where stated otherwise, the stand area and any materials that shall be made available to the Exhibitor shall be deemed to be in good condition.

The rented stand and/or any materials provided as part of the layout and/or decoration of the stand shall be returned to the Organiser in good working order. The repair of any degradations caused to the building or land let to the Exhibitor and identified when the stand space is returned to the Organiser shall be invoiced directly to the Exhibitor.

13. PERMITTED PRODUCTS, BRANDS AND SERVICES

The Exhibitor is prohibited from exhibiting at its stand any products, brands or services other than those set out on its registration form or its online stand reservation application and which are accepted by the Organiser.

Moreover, the Exhibitor hereby declares and warrants that it holds all rights relating to the products and/or services exhibited, or in the alternative case, that it has been authorised by the rights' holder(s) to exhibit the products, brands or services at its stand.

The Exhibitor hereby warrants that the products and/or services it exhibits comply with any applicable safety standards in force and hereby accepts full liability for any defects of the aforementioned products and/or services, such that under no circumstances shall any party be able to impart any liability to the Organiser in relation to the aforementioned products and/or services.

14. INTERNET SERVICES

The Exhibitor shall be exclusively liable for the contents of any information supplied by it for the purposes of publication on the Exhibition website, and in particular for information related to its products and/or services and the characteristics, performance and prices etc. thereof.

The Exhibitor hereby warrants that the aforementioned information is lawful and in particular that it complies with any applicable regulations in force relating to the name, the description, the offer, the presentation, the user manual and

the description of the scope and terms and conditions of any guarantee for any goods, products or services that may be published online and generally, that any information complies with any publicity and/or consumer protection laws in force.

The Exhibitor shall be exclusively liable for the publication of all texts, logos, illustrations, photographs and pictures, products and brands and only the Exhibitor shall hold any reproduction rights in relation thereto.

The Exhibitor hereby agrees to indemnify the Organiser against any voluntary or judicial proceedings brought by any third party.

15. ILLICIT TICKET TOUTING

The act of offering for sale or showing with the intention to sell or transfer or supplying with the intention to sell or transfer any Exhibition access passes (entry passes, invitations, tickets etc.) in a public or private place or on the Internet, without the authorisation of the Organiser, is a criminal offence punishable by questioning and arrest by the police and a fine of €15,000. In the event that such an offence is repeated, the fine is increased to €30,000.

16. INVITATION CARDS

The copying or re-sale of invitation cards is strictly prohibited and shall be subject to prosecution and/or other sanctions.

Furthermore, in the event that any fraudulent use of an invitation card is brought to its attention, the Organiser reserves the right to withdraw the invitation.

17. DEMONSTRATIONS AND OTHER EVENTS

a) Demonstrations

Demonstrations may only be held at the Exhibition for those products that require a specific technical explanation. Furthermore, such demonstrations may only take place where the Organiser has given a special prior written authorisation. Demonstrations on a raised podium are strictly prohibited. Demonstrations carried out using a microphone, or which harangue or solicit in whatsoever manner, are strictly prohibited. Any full or partial closure of an Exhibitor's stand during normal opening hours to the public and, in particular, during any demonstration, is strictly prohibited without express prior written authorisation from the Organiser.

b) Other events

All attractions, shows or animations taking place within an Exhibitor's stand area must be authorised in advance by the Organiser. To this end, the Exhibitor shall provide to the Organiser specific details of any such project (such as the materials and sound sources intended to be used, the type of animation intended to be put on/displayed etc).

In any event, the power of any loud speakers intended to be used may not exceed 30 decibels (dB) and they shall be turned inwards towards the interior of the stand and angled towards the floor. The sound level shall not exceed 85 decibels (dB).

c) Under no circumstances shall any demonstration or event take place in a manner so as to interfere with the neighbouring Exhibitor(s) or the general movement around the Exhibition and, more generally, with the proper carrying out of the Exhibition. In the event that there is a breach of the provisions of the present sub-cause, the Organiser reserves the right to revoke any authorisation for the relevant demonstration or event forthwith and without further notice.

18. ADVERTISING

All advertising using sound or lighting must comply with the regulations concerning the decoration of the Exhibition and shall be subject to the prior written agreement of the Organiser. Any such agreement shall be conditional upon

the advertising not interfering with any neighbouring Exhibitor(s) or the general movement around the Exhibition and, more generally, with the proper carrying out of the Exhibition. In the event that there is a breach of the present sub-cause, the Organiser reserves the right to revoke any authorisation for the relevant demonstration or event forthwith and without further notice.

Distribution in the Exhibition pathways and within the entrance hall of the Exhibition, of brochures, flyers, vouchers or other printed matter intended to encourage Exhibition visitors to go to the Exhibitor's stand, is strictly prohibited. Only those brochures, flyers, vouchers or other printed material that are displayed and offered within the interior of the Exhibitor's stand are authorised.

Any documentation given to any visitor to an Exhibitor's stand, such as a business card or order form, shall bear the brand or trade mark or the company name of the Exhibitor as set out on its registration form.

19. METHOD OF SALE / UNFAIR COMPETITION

The Exhibitor is hereby reminded that the French Consumers Code [le Code de la Consommation] expressly prohibits sales at a premium (article L 121-35 of the Consumers Code), sales at loss (article L 442-2 of the Consumers Code), pyramid selling (article L 122-6 of the Consumers Code) and related sales transactions (article L 122-1 of the Consumers Code) as well as false sales.

Any sale by auction shall comply with the applicable legislation in force (law number 2000-642 of 10 July 2000 relating to the regulation of voluntary sales of chattels by public auction).

The exhibitor undertakes to remind visitors that any purchases made at the Exhibition, other than those subject to a consumer credit agreement (article L311-12 of the Consumers Code) and those arising from a personal invitation to come to a stand to receive a gift, shall not benefit from the right to cancel the purchase.

The Exhibitor is hereby expressly prohibited, for the entire period of the Exhibition, from engaging in acts of unfair competition such as conducting surveys and distributing advertising items outside its stand area, where such surveys or distribution give rise to the diversion of visitors to the Exhibition in favour of the Exhibitor.

The Exhibitor is obliged to ensure that any agreements it enters into with visitors to the Exhibition are executed in good faith.

20. COUNTERFEIT ITEMS

The Exhibitor shall personally undertake to ensure the protection of any intellectual/industrial property rights related to the materials, products, services and brands exhibited in accordance with any applicable legislation or regulatory provisions in force, and the Organiser shall not be held liable for any failure on behalf of the Exhibitor to comply with the provisions of the present clause, in particular in the event of any action brought by another Exhibitor or a visitor to the Exhibition.

In the event that a competent court finds that the Exhibitor has breached the provisions of the present clause, the Organiser reserves the right to oblige the Exhibitor to comply with any stipulations made in the court's findings.

Failing that, the Organiser reserves the right to refuse entry to the Exhibitor or to enforce any sanctions referred to in the Terms and Conditions without giving rise to any claims or compensation of whatsoever nature by or for the Exhibitor.

21. DISPLAYING PRICES

Prices shall be displayed clearly using the French language and shall be inclusive of all taxes and in compliance with any applicable legislation in force so as to ensure that the general public is properly informed thereof. Any price

reduction announcements (discount, rebate or repayment) made by way of labelling, marking or display shall be in accordance with any applicable legislation and regulations in force relating to the provision of prices to consumers, and may only be effected inside the stand area by way of notices such as small posters. The maximum size of any such notices or posters shall be 30cm x 20cm.

22. SALES FOR TAKE AWAY

Unless stated otherwise, any sale whereby a purchaser may take immediate possession at the Exhibition of the purchased items is prohibited.

In any event, and where authorised to sell such items, the Exhibitor hereby undertakes to comply with any applicable regulations in force on the day(s) of the Exhibition relating to the sale of items for immediate take away.

23. SACEM DECLARATION

Exhibitors wishing to play music at their stands must give the Organiser prior written notice of the same. It is furthermore hereby expressly stipulated that the Exhibitor shall be exclusively liable for compliance with any intellectual property regulations and/or legislation relating to the playing of music. Thus the Exhibitor shall make any necessary declarations relating to the playing of music to SACEM [the French collecting society] and hereby undertakes to make any requisite payments.

The Exhibitor hereby indemnifies the Organiser against any claims and/or action brought by any third party as.

24. TAKING PHOTOS/BRANDS

The exhibitor hereby and for no charge expressly authorises the Organiser and the COMEXPOSIUM group:

- to take, should they wish to do so, photographs and/or films featuring the Exhibitor and/or members of its team, as well as any products exhibited at its stand.
- to use any such images freely on any media and in particular for the purposes of advertising material (including on the Internet) in France and worldwide and for a duration of five years beginning from the date of their Exhibition registration form;
- to cite and reproduce, for no charge, its trade mark or company name as a commercial reference for the purposes of communication on any medium whatsoever (in particular the Internet) whether in France or elsewhere and for a period of 5 years beginning from the date of their Exhibition registration form.

Any Exhibitor who does not wish for all or part of their stand or any elements thereon (logo, trade mark, model) or any members of their team to appear in photographs or films and/or on the Internet by way of advertising material promoting the Exhibition, must advise the Organiser of this in writing before the start of the Exhibition.

- Furthermore, any Exhibitor wishing to take photographs of the Exhibition must inform the Organiser in writing of the same before the start of the Exhibition. Furthermore, the Exhibitor shall personally ensure it possesses all necessary authorisations to take photographs of the Exhibition and shall be exclusively liable for complying with any image rights enjoyed by Exhibitors.

25. CATALOGUE

The Organizer shall be solely entitled to publish the Event catalogue or to have it published and distributed. Information to be published in the catalogue shall be provided by the exhibitors under their own responsibility. The Organizer shall under no circumstances whatsoever be held liable for any omissions, reproduction typesetting or other errors which may occur.

26. REGULATIONS

Exhibitors shall be familiar with and shall comply with any applicable regulations in force at the time of the Exhibition

as issued by any competent public office or by the Organiser, in particular the no-smoking rules that apply to the public areas, the Fire Safety Regulations and the Health and Safety [Protection] Regulations.

The Fire Safety Regulations and the Health and Safety [Protection] Regulations shall be communicated to the Exhibitor by way of the Exhibitor's Guide.

The Organiser hereby strictly prohibits the operation of any stand that does not conform to the aforementioned regulations.

27. EXHIBITOR'S GUIDE

All information relating to the Exhibitor's participation in the Exhibit shall be supplied to the Exhibitor once a stand has been allocated, by way of the Exhibitor's Guide which is sent to each Exhibitor and which is available on the Exhibition website. The Exhibitor hereby undertakes to comply with the security provisions and the customs formalities, as well as the limitations imposed on the fitting out and decoration of the stands.

28. CUSTOMS

Each Exhibitor shall be responsible for carrying out any applicable customs formalities in respect of any materials and/or products originating from abroad.

The Organiser shall not be held liable for any difficulties arising in connection with such formalities.

The Exhibitor hereby indemnifies the Organiser against any claims and/or actions arising in relation to the customs regulations and formalities and shall pay compensation to the Organiser for any loss suffered as a consequence of its failure to comply with the applicable customs formalities.

29. CANCELLATION OF THE EXHIBITION DUE TO A FORCE MAJEURE EVENT

En cas d'annulation du Salon par l'Organisateur pour survenance d'un cas de force majeure l'Organisateur en avisera sans délai les Exposants.

Dans une telle hypothèse, il n'y aura lieu à aucun dommages - intérêts et les sommes perçues par l'Organisateur seront restituées à l'Exposant.

Seront considérés comme cas de force majeure les événements :

> revêtant cette qualification admise par la jurisprudence française,

> ainsi que, et ce quelle que soit leur cause, les événements rendant impossible l'exploitation du Site limitativement listés ci-après :

- incendies, explosions, inondation, tempête, foudre,
- détérioration des équipements techniques rendant impossible l'exploitation du Site
- inondation, violente tempête, détérioration par la foudre
- décision par une autorité administrative de la fermeture du Site ou réquisition.

30. THE ORGANISER'S LIABILITIES

The Organiser shall not be held liable for any injury or commercial loss that the Exhibitor may suffer for whatsoever reason.

31. COMPLAINTS AND DISPUTES - GOVERNING LAW - JURISDICTION

All complaints shall be sent by registered post with recorded delivery within 10 (ten) days of the end of the Exhibition.

The parties shall endeavour to settle amicably and forthwith, any dispute that may arise between them in relation to the interpretation and/or the execution of the Terms and Conditions. Any dispute that cannot be settled in

this manner shall be subject to the exclusive jurisdiction of the competent court(s) of Nanterre, France.

Participation in the Exhibition, as well as any acts undertaken as a consequence of this participation, shall be subject to French laws and regulations.

32. TOLERANCE

Any tolerance shown by the Organiser in respect of any partial or complete failure by the Exhibitor to carry out any provision(s) set out in the present Terms and Conditions shall under no circumstances, irrespective of the duration or frequency thereof, give rise to any rights for the benefit of the Exhibitor nor shall such tolerance modify, by any means or in any manner, the extent of or performance of the Exhibitors obligations as set out herein.

33. INVALIDITY

In the event that one or more provisions of the Terms and Conditions are found to be invalid and/or unenforceable or declared as such under any law, regulation or following the decision of a competent court, the remaining provisions shall remain applicable.

34. SANCTIONS

In the event of any breach of the Terms and Conditions and/or any general regulations, the Organiser, having given formal notice in the presence of a bailiff in respect thereof and where the breach remains unremedied, shall have the right to close the corresponding Exhibitor's stand forthwith and prevent the Exhibitor from entering the stand area, without such an action giving rise to a right to claim material or non-material damages from the Organiser in respect thereof.

The Exhibitor shall be liable for any costs arising from the intervention of the Organiser (bailiff's fees and/or fees relating to the closure of the stand).

In any event, once any breach has been identified, the Organiser shall have the right to terminate this contract without incurring liability for any losses suffered by the Exhibitor, and shall have the right to repossess the stand area forthwith.

Furthermore and in addition to the previous paragraph(s), the Organiser shall have the right, for a period of three (3) years, to refuse the Exhibitor admission to any Exhibition held by any company within the COMEXPOSIUM group.

General rules and regulations governing exhibitions



CHAPTER 1: GENERAL PROVISIONS

01.01 These rules and regulations are general and apply to all exhibitions organised by Federation members.

All the events listed in Article R762-4 of the French Commercial Code (Code du commerce) *inter alia* are classified as exhibitions. No exhibition has any connection with previous or subsequent sessions: it is a single event defined by a name, place, date and a description of the products and/or services offered to the public, commonly known as the "nomenclature". These rules and regulations will, if necessary, be supplemented by special rules and regulations specific to each event, or by a "guide" or "exhibitors' manual".

The term "special rules and regulations" means the provisions specifically applicable to any such exhibition which supplement the general rules and regulations governing all exhibitions. The special rules and regulations may not contradict the general rules and regulations in any event. The special rules and regulations may be supplemented by a "guide" or "exhibitors' manual" if necessary.

The term "guide" or "exhibitors' manual" means the document given, sent or made available online by the organiser at the time when the exhibitor applies to take part in the exhibition, containing information relating to the exhibition, the rules and regulations, forms on which to order services and all other relevant information affecting the exhibitor's participation in the exhibition. All of the provisions of this document will apply to the exhibitor.

The term "stand" means the space taken up for the presentation of products or services, or the space in which customers or players operating in the same sector are brought together.

The term "exhibition catalogue" means an electronic or paper document containing a list of the exhibitors, their contact details, the stand numbers and all other information relating to the exhibition.

"In the event of doubt about a particular definition, please refer to ISO document 25639-1 International Standard – Exhibitions, shows, fairs and conventions".

By signing the registration form, exhibitors accept all of the requirements laid down therein as well as any that may be imposed in the event of special or new circumstances. In addition, they undertake to comply with all of the statutory and regulatory requirements in force, particularly labour legislation and safety regulations.

01.02 The organiser alone shall determine the place, duration, opening and closing times of the event, the price of the stands, and the admission price as well as the closing date for registrations. It alone shall determine the categories of persons or companies allowed to exhibit and/or visit the event, as well as the nomenclature of the products or services presented.

CHAPTER 2: APPLICATION TO PARTICIPATE AND FOR ADMISSION TO EXHIBIT

02.01 Persons/entities wishing to participate should complete the application form prepared by the organiser, which is available electronically or on paper. Potential exhibitors will not be deemed to have been admitted to exhibit merely because they have requested an application form, nor because an application form has been sent, nor because a reservation cheque has been collected.

02.02 The organiser shall process the exhibitors' applications to participate and rule on the admissions. Admission only becomes effective when written confirmation is sent to the exhibitor.

02.03 The organiser will have sole discretion with respect to the definition and organisation of the products and/or services offered at its exhibition. The organiser (or the selection committee) therefore reserves the right to reject, provisionally or permanently, any application to participate that does not comply with the required conditions, either with respect to the stipulations laid down on the application form, or with respect to those contained in the general rules and regulations governing exhibitions and/or the special regulations or the nomenclature of the exhibition, or else in the light of Public Policy or the defence of certain protected interests.

02.04 An application may be rejected provisionally or permanently for any of the following reasons, *inter alia*: failure to provide all the necessary information; failure to make payments or provide guarantees required by the organiser; non-observance of prior obligations and in particular of these general rules and regulations; applicant's non-compliance or the non-compliance of its products or services with the purpose, spirit or image of the event; the exhibitor's going into court-ordered administration; the exhibitor's proven insolvency; failure to obtain administrative or judicial authorisations allowing it to be present at the event; the risk, due to its presence, of interference with the protected interests of consumers and of young people; and more generally the risk, due to its presence, of breaches of Public Policy, of interference with other exhibitors' pursuit of their activities, or with visitors' safety and enjoyment.

02.05 The exhibitor must inform the organiser of any element or event that occurs or is disclosed after its application to participate, that would justify reconsideration of its application to participate in the light of articles 02.03 and 02.04 of these rules and regulations.

02.06 In addition, the organiser reserves the right to request, at any time, additional information relating to the foregoing and, if appropriate, to reconsider an admission decision that was made on the basis of deceptive or erroneous information or information that has become inaccurate.

The down-payment made will then remain the property of the organiser, which also reserves the right to seek payment of the price in full.

02.07 The right arising from admission to the event is personal and non-transferable. Admission does not create any right to be admitted to any other event organised by the organiser.

02.08 Unless the organiser has allowed a departure from the normal rule on the basis of an explicit request on their part, groupings may exhibit on collective stands only if each business that is a member of the grouping has been admitted individually and has undertaken to pay the registration fees.

CHAPTER 3: REGISTRATION AND PARTICIPATION FEES

03.01 The application or applications for participation must, under penalty of immediate rejection, be accompanied by the first payment set by the organiser. The organiser may be entitled to retain the administrative or registration fees, whether the application for participation is accepted or not.

03.02 The organiser will be entitled to retain the total amount of the fee charged for participation in the event after written notice of the admission decision has been sent to the exhibitor. Should the balance not be paid on the stipulated

date, or should any of the payments not be made on any of the stipulated dates, the exhibitor's admission to exhibit will be terminated, without any formal warning, and the organiser will be entitled to retain the down-payment already made, irrevocably.

03.03 The organiser also reserves the right to seek payment of the balance of the payable price, even if the exhibitor has not participated for any reason whatsoever, in spite of being admitted to exhibit. If an exhibitor does not occupy its stand on the day on which the event opens, for any reason whatsoever, or by the organiser's set up deadline, it will be deemed to have given up its right to exhibit. Without prejudice to any other measures that may be taken, the organiser may dispose of the absent exhibitor's stand, without the exhibitor being entitled to claim any reimbursement or indemnity, even if the stand is assigned to another exhibitor.

03.04 The special rules and regulations applicable to each event may, if appropriate, lay down the conditions under which the exhibitor may cancel in appropriate cases, and the procedures to be followed, even though it has been definitely admitted to the exhibition.

CHAPTER 4: ASSIGNMENT OF PLACES

04.01 The organiser shall draw up the event plan and assign the places.

04.02 The organiser or selection committee may, within the framework of the special rules and regulations for each event, determine the maximum space available for each type of activity or service marketed and/or the maximum number of exhibitors. The acceptance of each exhibitor's application for participation will then depend upon the places that are still vacant in the business sector considered when the application for participation is made. In order to take account of the specific features of each event, the organiser or the selection committee will, however, retain the right to change the distribution initially planned, considering the objective elements to be applied to all exhibitors.

04.03 Unless the organiser or selection committee stipulates otherwise, admission to exhibit does not confer any right to occupy a specific place. Participation at previous events does not create an established right to a specific place for the exhibitor.

04.04 When the lots are drawn up and the places allocated, the organiser and the selection committee shall make every effort to take account of the wishes expressed by the exhibitors, the nature and interest of the items or services that they propose to present, and the layout of the stand that they envisage setting up.

04.05 If the venue at which the event is to be held so allows, the plans filed and the descriptions of the lots shall include dimensions that are as precise as possible, and specify the places and types of activity that will be organised during the exhibition. When the exhibitor has been informed by the organiser of the advantages and possible disadvantages of its stand being close to the activities, and if it did not object to the location before the beginning of the exhibition, it will be deemed to have accepted any inconvenience and agrees not to bring any action against the organiser in connection with its direct environment, of which it was not previously informed.

04.06 Should there be an absolute need, the organiser reserves the right to amend the following items whenever it deems it useful to do so, in the interests of the event, and at any time, before or during the event, without having to give prior notice thereof to the exhibitor: the general and specific decoration, the opening times and the schedule of the activities; provided this does not significantly change the initial contract that was signed between the organiser and the exhibitor. Should this contract be changed significantly, the organiser shall make every effort to find a solution that is acceptable to the exhibitor.

CHAPTER 5: BUILD UP, SET UP AND CONFORMITY OF THE STANDS

05.01 The "guide" or "exhibitors' manual" specific to each event, as defined in article 01.01, will determine inter alia the time available to the exhibitor, before the opening of the event, when it will be able to fit out its stand and store any items that it will need during the event at the stand.

05.02 During the build up period, the exhibitor is required to comply with the "Charte professionnelle visant à organiser l'hygiène et la sécurité des salariés en situation de coactivité pendant les opérations de montage et de démontage des manifestations commerciales" (Professional plan for the health and safety of employees involved in joint activities during the build up and tear down periods for exhibitions) drawn up by FSCEF (Foire, Salons, Congrès et Evénements de France or French Federation of the Exhibition and Meeting Industry) and adopted at its General Meeting on 2 July 2010.

05.03 The exhibitor must comply with the organiser's instructions relating to the regulation governing arrivals and departures of goods and other items, particularly with respect to vehicle traffic on the event premises.

05.04 The exhibitors or their principals must have completed their set up on the dates and at the times stipulated by the organiser. After the said dates and times, no packing, equipment, transport vehicles or outside contractors may access, be kept on or remain at the event site, for any reason whatsoever and however harmful that may be to the exhibitor's interest.

05.05 Each exhibitor or its principal shall be responsible for the transport, reception and shipment of its parcels or other consignments, and for acknowledgement of their contents. All parcels or other consignments must be unpacked upon arrival. If the exhibitors or their representatives are not present to receive their parcels, or other consignments, the organiser, given the liabilities incurred, will refuse the parcels or other consignments marked for the attention of the exhibitor in its absence, unless there are contractual provisions to the contrary. The exhibitor will not be entitled to claim compensation for its loss due to the refusal to receive its parcel or other consignment.

05.06 The setting-up of the stands must not, in any event, damage or change the permanent installations at the exhibition venue, and must not detract from the convenience or the safety of the other exhibitors and visitors. The exhibitor will be liable for all damage it causes. To this end, the exhibitor shall take out an insurance policy to cover damage caused.

05.07 The special decoration of the stands shall be carried out by the exhibitors under their responsibility. It must fit in with the general decorations of the event, but must not interfere with the visibility of the signs and safety equipment, not affect the visibility of the neighbouring stands and not conflict with any stipulations in the organiser's special rules and regulations or those of the host site and/or the "guide" or the "exhibitors' manual".

05.08 In the exhibition spaces, all the materials used, including hangings and carpeting, must comply with the rules and regulations in force. The organiser has a permanent right to have any equipment or installations that are not in compliance removed or destroyed, at the exhibitor's expense.

05.09 On its own initiative or at the request of an exhibitor whose interests have been harmed, the organiser reserves the right, before the event opens or during the event, to remove or change installations that detract from the general appearance of the event, interfere with the neighbouring exhibitors or visitors, or do not comply with the plans or particular projects previously submitted. The organiser shall assess the specific situation at its own discretion and has only a best-endeavours obligation if it decides to act in response to the request made by the exhibitor whose interests have been harmed.

05.10 The exhibitor or any person duly appointed to represent it must be present on its stand, when the stand is inspected by the safety officers, and shall comply throughout the event with the safety measures imposed by the authorities, with the safety measures adopted by the organiser or the site manager, and with the "Charte professionnelle visant à organiser l'hygiène et la sécurité des salariés en situation de coactivité pendant les opérations de montage et de démontage des manifestations commerciales" (Professional plan for the health and safety of employees involved in joint activities during the build up and tear down periods for exhibitions).

CHAPTER 6: OCCUPATION AND USE OF THE STANDS

06.01 Exhibitors participating in the event are specifically forbidden from transferring, subletting or exchanging, with or without consideration, all or any part of the place allocated by the organiser.

06.02 Unless it has prior, written authorisation from the organiser, the exhibitor may not display, at its place, equipment, products or services other than those listed in the application to participate, and that comply with the nomenclature of products or services drawn up by the organiser. Unless there is an express stipulation to the contrary, it is strictly forbidden to display and offer used items.

06.03 The exhibitor may not present products or services or advertise businesses or contractors that are not exhibitors, in any form whatsoever, except with the organiser's prior, written authorisation.

The exhibitors may not, in any form whatsoever, advertise a practitioner or establishment that belongs to a regulated profession whose advertising rules are restricted by the official, national body that represents the profession. It is understood that having a stand is not a form of advertising.

06.04 The stands must be kept in impeccable condition throughout the event. Each stand must be cleaned every day, on the exhibitor's responsibility and at its expense. The cleaning must be completed by the time the event is opened to the public.

06.05 The rental of a stand is not a contract for the storage of goods. In the event of theft from a stand, the exhibitor will have no claim against the organiser.

06.06 Exhibitors may not strip their stand, nor remove any of their items, before the end of the event, even if the event is extended.

This article may be supplemented by a requirement to pay a deposit in the organiser's special rules and regulations.

06.07 Bulk packing, the covers used when the event is closed, items and equipment not used in stand presentation and the staff cloakroom must be out of the sight of visitors. Conversely, it is forbidden to leave the items that are supposed to be on display covered during the business hours of the event. The organiser reserves the right to remove covers from items without being held liable, in any way, for damage or losses that might result from such an action.

06.08 Any failure to comply with any of the foregoing provisions will be recorded in writing by the organiser and may be used as a ground to refuse to allow the exhibitor to participate at future events.

CHAPTER 7: ACCESS TO THE EVENT

07.01 Only persons holding tickets issued or accepted by the organiser may be admitted to the event venue.

07.02 The organiser reserves the right to refuse entry or to expel any person, whether a visitor or exhibitor, whose presence or behaviour is harmful to the safety, peace or image of the event and/or to the integrity of the site.

07.03 The sale and tasting of alcohol are authorised, except to minors under the age of 18, provided the relevant legislation in force is complied with.

07.04 It is strictly forbidden to smoke within the area of the venue that is open to the public, other than in the places reserved for smokers.

Any person who smokes outside the places reserved for smokers will be liable to pay a fixed penalty of €68 (for a class 3 petty offence). Failure to enforce the standards applicable to reserved places or to install the related signage, will be punished by a fixed penalty of €135 (for a class 4 petty offence). Any person who knowingly facilitates a breach of the prohibition on smoking will also be deemed to have committed a class 4 offence, however, this offence does not carry a flat rate penalty, as the specific details of the offence must be recorded. A report will be sent to the prosecuting authority which will decide whether or not to open criminal proceedings.

07.05 Tickets granting the right to enter the event are delivered to the exhibitors under the conditions laid down by the organiser.

07.06 Tickets for the persons or companies that they wish to invite are delivered to the exhibitors under the conditions laid down by the organiser. Unused tickets may not be returned or exchanged and will not be reimbursed.

07.07 The distribution and/or sale, by an exhibitor with a view to making a profit, of tickets issued by the organiser for good consideration or free of charge, is strictly forbidden. The reproduction or sale of the said tickets may lead to court proceedings.

CHAPTER 8: CONTACT AND COMMUNICATION WITH THE PUBLIC

08.01 The exhibitors and their staff must be smartly dressed and extremely polite to all other persons, such as visitors, other exhibitors, organisers, security staff, hostesses or all other service providers. The staff must not bother customers nor move outside the stand.

Any failure to comply with this provision will be recorded in writing by the organiser and may be used as a ground to refuse to allow the exhibitor to participate at future events.

08.02 The stand must be occupied by the exhibitor or its representative at all times during the hours when the venue is open to exhibitors (including during the build up and tear down periods and when deliveries are made), and at all times during the hours when the exhibition is officially open to visitors.

Any failure to comply with this provision will be recorded in writing by the organiser and may be used as a ground to refuse to allow the exhibitor to participate at future events.

08.03 The organiser has the sole right to write, publish and distribute the exhibitor's event catalogue, free of charge or for good consideration. It may assign all or part of this right, as well as the advertising included in the said catalogue. The information required for inclusion in the catalogue will be supplied by the exhibitors on their own responsibility and under penalty of non-inclusion, within the time limit set by the organiser.

08.04 The organiser may, without specific agreement, include the exhibitor's company name in exhibition information, particularly catalogues intended for visitors and/or exhibitors, or on its website. Should the organiser wish to distribute the exhibitor's personal data, which was collected when the exhibitor registered with the exhibition, with the exhibition information, it must inform the exhibitor before doing so.

However, when the exhibitor registers, the organiser shall ask for its consent to use its image (including its sign, logo, products or services, or photograph of the stand) and name in all canvassing documents and media, for the purposes of advertising and promoting the exhibition. When the exhibitor gives its agreement, there is a presumption that its employees and/or subcontractors have also agreed to the

organiser possibly using their images at the time of the exhibition.

When agreement has been reached, the organiser, producer or distributor may not be held liable on account of the distribution of its image, the image of its stand, its sign, its trademark, its staff, or its products or services, by television, video or any other medium, including virtual media (books, brochures), in France or abroad, for the purposes of the event.

08.05 The organiser reserves the sole right to put up posters at the event venue. Therefore the exhibitor may only display, and only on its own stand, posters and signs of its own company, whose name it gave when it registered to take part in the exhibition, to the exclusion of all others, within the limits of the requirements concerning the general decoration.

The organiser may require posters and signs that do not comply with this provision to be removed.

08.06 Brochures, catalogues, printed matter, free gifts or items of any kind whatsoever may only be distributed by the exhibitors on their own stand. Brochures relating to products, trademarks or services that are not on display may only be distributed with the organiser's written consent.

08.07 It is forbidden to distribute or sell newspapers, periodicals, brochures, raffle tickets, badges, vouchers or coupons, even if they relate to charitable work or a charitable event, and to conduct opinion polls, at the event venue and in its immediate vicinity, unless the organiser has granted an exemption from this rule.

08.08 Any light or sound advertising and any promotion, entertainment or demonstration that could cause crowding in the aisles must have the organiser's prior approval. The organiser will be entitled to revoke any authorisation that may have been granted, in the event of disturbance to movement, to neighbouring exhibitors, or to the event itself.

08.09 Audible advertising and touting, in any form whatsoever, are strictly forbidden. The exhibitors must not obstruct the aisles or encroach upon them, in any circumstance, unless they have exceptional, prior, written authorisation from the organiser.

08.10 The exhibitors must make every effort to provide the public with fair, objective and comprehensive information about the qualities, prices, and sales conditions of their products or services, and the related warranties, in compliance with the rules and regulations. They must not use any advertising or carry out any action whatsoever that could mislead or constitute unfair competition.

Exhibitors are informed that purchases made at the event are not subject to Articles L 311-10 and L 311-15 of the French Consumer Code (Code de la consommation) (seven-day cooling-off period) except for purchases that are covered by a consumer credit agreement, and purchases that result from a personal invitation to go to a stand to collect a gift.

Should any exhibitor be found to be claiming the opposite, the organiser may impose sanctions which could include the immediate closure of the stand.

08.11 The exhibitors undertake to present only products, services or equipment in compliance with French or European rules and regulations. They will be fully liable for their products vis-à-vis third parties, and the organiser will have no liability whatsoever in the event that an exhibitor fails to comply with the law.

08.12 It will be up to each exhibitor to complete the formalities involved in its participation in the event, as necessary, particularly those relating to labour regulations, customs requirements with respect to equipment or products coming from abroad, and those relating to hygiene with respect to food products or animal species.

CHAPTER 9: INTELLECTUAL PROPERTY AND OPERATING OR MARKETING RIGHTS

09.01 In accordance with the "Charte de la lutte contre la contrefaçon" (Plan to combat counterfeiting and infringement) voted by FSCEF General Meeting in July 2008, any exhibitor that wishes to bring an action before an administrative or ordinary court for counterfeiting or infringement against a rival exhibitor, undertakes to give prior notice thereof to the organiser of the event or its appointed representative, to behave honestly and to act in good faith.

09.02 The exhibitor shall assume responsibility for the intellectual protection of and the rights to operate or market the equipment, products and services it displays (patents, trademarks, models, etc.), in accordance with the statutory and regulatory provisions in force. The said measures must be taken before the equipment, products or services are presented. The organiser declines all liability in this regard, particularly in the event of a dispute with another exhibitor or visitor.

09.03 Each exhibitor shall assume responsibility for its obligations to the SACEM (Société des auteurs, compositeurs et éditeurs de musique or French Society of Authors, Composers and Publishers of Music) if it uses music at its stand and as part of promotions that are specific to it, even for ordinary demonstrations of sound equipment. The organiser declines all liability in this regard.

09.04 Unless the organiser makes specific provisions or gives written authorisation, photographs other than specific images of the exhibitor's stand may not be taken at the exhibition venue, nor may films be shot. Accreditation constitutes written authorisation to take photographs or shoot films, provided third parties' image rights are respected.

09.05 The photography of certain items at the stands may be forbidden at the exhibitors' request and on their initiative.

CHAPTER 10: INSURANCE

10.01 In addition to the insurance covering the items on display and more generally all movable or other items in its possession, the exhibitor is required to take out at its own expense, either with its own insurer or with the insurer approved by the organiser, all insurance to cover the risks incurred by itself and by its staff, or that it causes third parties to incur. It shall provide evidence thereof, when its registration is confirmed, by producing a certificate of insurance. The organiser will be deemed to be discharged of all liability, particularly in the event of loss, theft or any damage whatsoever.

10.02 The organiser may, if necessary, require the exhibitor to take out the said insurance cover with a specific, named insurance company, in which case the rates and contract clauses will be specified for its benefit.

CHAPTER 11: TEAR DOWN OF THE STANDS AT THE END OF THE EXHIBITION

11.01 The exhibitor or its representative is required to be present at its stand when the tear down starts, and until the stand has been completely removed.

11.02 During the tear down period, the exhibitor is bound to comply with the "Charte professionnelle visant à organiser l'hygiène et la sécurité des salariés en situation de coactivité pendant les opérations de montage et de démontage des manifestations commerciales" (Professional plan for the health and safety of employees involved in joint activities during the build up and tear down periods for exhibitions) drawn up by FSCEF.

11.03 The stands, goods, items and special decorations, along with the waste remaining from the materials that were used to decorate the stands, will be removed by the exhibitors within the periods and at the times specified by the organiser, in compliance with the laws, rules and regulations and local practice regarding waste materials.

After these deadlines, all costs incurred due to any failure to follow these instructions shall be borne by the exhibitor. In addition, the organiser may be entitled to have the items shipped to a depository of its choice at the exhibitor's expense and risk, and the organiser will not be held liable for any total or partial loss or deterioration.

11.04 The exhibitors must leave the places, decors and equipment made available to them in the condition in which they found them. Exhibitors responsible for any deterioration caused by their installations or their goods, either to the equipment or the building, or else to the floor space occupied, will be held liable therefor, upon presentation of evidence in support.

CHAPTER 12: DAMAGE

12.01 The term damage is understood to mean "property damage or non-pecuniary damage sustained by a person due to the action of a third party".

When an exhibition is held, damage may occur:

- between exhibitors
- between exhibitors/organisers
- between organisers/exhibitors
- between organisers/customers

12.02 When an exhibitor suffers damage due to the action of another exhibitor, both must settle the dispute in a responsible fashion, as far as possible. The organiser must be kept informed of the dispute but has no obligation to act as a mediator or arbitrator. Its role is to check that the contractual provisions governing its relations with the exhibitor are complied with. If one of them decides to invite an authority to intervene, it has a duty to warn the organiser in order to preserve the image of the exhibition as far as possible.

12.03 When damage occurs as the result of a dispute between an organiser and an exhibitor and affects another exhibitor, the exhibitor must submit a written request to the organiser. The organiser shall reply to the exhibitor's request promptly, provided the request is legitimate and justified. The organiser will have only a best-efforts obligation.

12.04 When the organiser suffers damage due to the action of an exhibitor, the former shall issue a notice requiring the exhibitor to cause the problem to cease. If this provision is not complied with, the organiser shall make a written record of its failure, which may be used as a ground to refuse to allow the exhibitor to participate at future events.

12.05 The organiser has a duty to provide general information about the general running of its exhibition.

12.06 The organiser has no obligation to intervene in disputes that may arise between exhibitors and customers and will not be held liable for disputes that arise between exhibitors and visitors, in any circumstance.

CHAPTER 13: MISCELLANEOUS PROVISIONS

13.01 The organiser may cancel or postpone the exhibition if it finds that the number of registrations is clearly insufficient. Registered exhibitors shall then be reimbursed for the amount of their down-payment or participation fee. Until the final day for registration, the exhibitor shall bear the entire risk relating to the fact that the exhibition may not be held, particularly the sole burden of the expenses it believes it will have to incur in anticipation of the exhibition.

13.02 The organiser may also cancel or postpone the event in case of a situation of force majeure. Situations of force majeure that justify the cancellation or postponement of the exhibition, at any time, are any new, health, climatic, economic, political or social situations, at local, national or international level, that are not reasonably foreseeable when the exhibitors are informed of the exhibition, that are beyond the organiser's control, that make it impossible to put on the event or that entail risks of disturbance or disorder that might seriously affect the organisation and proper running of the event or the safety of property or persons. The possibility of the exhibition being postponed and/or the treatment of the sums paid will be determined in each organiser's special rules and regulations.

13.03 Any breach of these rules and regulations, of the special rules and regulations by which they are supplemented, or of the specifications in the "guide" or "exhibitors' manual" issued by the organiser, may lead to the closure of the stand of the exhibitor in breach, with police assistance if necessary.

13.04 In such situation, the exhibitor's participation fee will be kept by the organiser, without prejudice to the payment of the balance of the price, of any amounts remaining due, or of any other cost incurred to close the stand. The organiser reserves the right to bring an action against the exhibitor at fault seeking compensation for the loss sustained.

13.05 Whatever the justification may be, complaints made by an exhibitor against another exhibitor or the organiser must be discussed away from the event and must not disturb the peaceful running or image of the event, in any way.

13.06 The exhibitor agrees not to refer any dispute to the courts before first attempting to find an amicable solution through the organiser.

13.07 In the event of a dispute, in principle, the courts in the place where the exhibition is held will have sole jurisdiction. Exceptionally, if an exhibition is organised abroad by a company whose registered office is in France, the competent court will be the court in the place where the organiser's registered office is located.

13.08 Any difficulties that arise in the construction of the English, German, Spanish, Italian or Chinese versions of these General Rules and Regulations will be resolved by reference to the meaning of the French version of the General Rules and Regulations.

Payment of comprehensive insurance for exhibitions

The organiser is not responsible for damage that the exhibitors may cause to, third parties or for damage to property of exhibitors.

However, the organiser recommends that exhibitors enrol in the insurance policy underwritten by COMEXPOSIUM ASSURANCES, on their behalf, with the AXA FRANCE company. This insurance policy covers damage to the exhibitors' property (loss, theft, destruction) and stand equipment, under the conditions and within the limits of the insurance policy, provided that the exhibitors enrol in said policy by taking out the insurance offered on the application form.

This AXA France insurance policy no. 4 299 10 204 is an appropriate solution based on the situation, the needs expressed and the financial terms and conditions of the policy (deductible, insurance benefit and premium).

It is recalled that the insurance taken out by the exhibitor does not cover the third party liability of the latter.

In this regard, the exhibitor acknowledges having taken out all the insurance policies necessary with an insurance company covering its third party liability and that of any person involved directly or indirectly in the exercising of its activities and/or those of its company, for any physical injuries, material or intangible damage caused to a third party during his attendance and/or that of its company at the Exhibition SIAL 2014 that shall take place from 19th to 23rd October 2014 (including during the assembly and dismantling periods).

The insurer: AXA France Company
26 rue Drouot -75009 Paris
Policy no. 4 299 10 204

I - COVER

A – PURPOSE AND SCOPE OF THE COVER

1/ Events insured

The insurance covers any material damage, losses and damage caused to the goods exhibited, including the fittings of the stands pursuant to any non-excluded event.

It is specified that acts of terrorism and attacks and Natural Disasters are only covered in France.

2/ Goods insured

The insurance covers the goods of the exhibitors and the co-exhibitors, and the fittings of the stands.

B – EXCLUSIONS OF COVER

The exclusion of cover clause is the clause whereby the insurer, when it defines the purpose of its cover, expresses its intention to exclude from said cover certain events, certain types of damage and, more generally, certain risks.

The insurer shall therefore not be liable for any event, property or damage excluded by it through the exclusion clauses in case of damage.

1/ Events excluded

Damage, losses and deterioration suffered by the goods insured are excluded from the cover that results:

- from foreign war or civil war,
- from the direct or indirect effects of an explosion, discharge of heat or radiation resulting from the transmutation of atoms or radioactivity as well as the losses due to the effects of radiation provoked by the artificial acceleration of particles,
- from confiscation, sequestration, seizure or destruction by order of any government or public authority, as well as the consequences of any infringements,
-

- of flooding or overflowing of stretches of natural or artificial water, rain water, floods, tidal wave, moving blocks of snow or ice or other natural disasters (except those covered under the Law on natural disasters no 82-600 of 13.07.82, cf. Article 2 above),
- of a specific defect, wear and tear, age, slow deterioration, moths, parasites and rodents of any kind,
- of the insufficiency or unsuitability of the packing or packaging,
- OF THEFTS,
- of the influence of atmospheric agents for object exposed to the air,
- of epizootic as regards animals,
- of the fading of flowers, trees and floral decorations as well as of any plants.
- of any losses or disappearances on the stands where free distributions or tastings are made of any goods or beverages whatsoever,
- of any sanitary or disinfection measures or cleaning, repair or renovation operations,
- of the defective assembly or dismantling of the objects insured,
- of the breaking of fragile objects such as porcelain, glassware, mirrors, marble, pottery, terra cotta, sandstone, ceramics, alabaster, plaster, waxworks, cast iron works, under glass or windows.

If the occurrence of these events cannot be excluded, it appears however that they are not likely to deprive the exhibitor of the protection of the coverage offered in a large number of circumstances during the exhibition.

Nevertheless, of these events excluded from cover, we draw your attention to acts of petty theft. Thus, such events may under no circumstances activate the insurance cover and shall therefore not be indemnified if they should occur.

2/ Goods excluded

We draw your attention to the fact that the following goods are excluded from the cover:

- Works of art,
- Objects of special value. An object of special value means an object whose intrinsic value is not related to the costs incurred to obtain it,
- Furs, skins and carpets,
- Cash and notes,
- Personal effects and objects, jewels, cameras, radios, electronic pocket calculators and all the objects belonging specifically to any person attending the event directly or indirectly,
- Connected telephones,
- Removable software and software packages,
- Plasma or LCD screens (the exhibitor can take out a specific insurance policy to cover this equipment).

3/ Damage excluded

The following items are always excluded from the cover granted by the Insurer:

- Indirect losses of any kind whatsoever such as loss of profits, damages, duties and other taxes, penalties of any kind and, notably, those relating to a deadline or delay for any reason whatsoever,
- Stains of animals,
- Damage caused to materials, clothes, fur, carpets, tapestries and covering (floors, walls, partitions) by marks, stains, dirty marks and burns of cigars, cigarettes and/or pipes, except those resulting from water damage, fire or theft,

Payment of comprehensive insurance for exhibitions (cont.)

- Scratches, scrapes, rust or any oxidation and/or corrosion,
- Damage to the objects exhibited under stands, when these goods are located outside of the latter,
- Damage, losses and deterioration suffered by the goods insured when this damage is the result of the operating or mechanical or electrical malfunction of the said objects.

C – AMOUNT OF THE COVER

The cover is fixed at € 500 per square metre rented with a minimum of € 6,000 and a maximum of € 400,000.

This amount is the limit of liability, i.e. the maximum amount of the insurer's obligation. Moreover, in case of loss, you may not obtain compensation in excess of the above-mentioned amount in the event that the insurance coverage is activated.

For all these reasons, we believe that the AXA France insurance policy no. 429910204 is an appropriate solution based on the situation, the needs expressed and the financial terms and conditions of the policy (deductible, insurance benefit and premium).

D - ADDITIONAL INSURANCE

Upon request to the organiser, exhibitors may take out the following additional insurances:

- for theft or misappropriations committed by the employees of the Insured Party or of the beneficiary as well as of the intentional or fraudulent fault of the insured party or of the beneficiary, who have the strict obligation to act in all circumstances as if they were not insured,
- for damage to property, if the value of the exhibited items exceeds the insured amount,
- for plasma and LCD screens.

The additional insurance enrolment form for the additional insurances above mentioned is attached to these insurance regulations and is also included in the Exhibitor's Guide, which will be accessible on the exhibition's website in May 2014.

II – INSURANCE CONDITIONS

A – TAKING OF EFFECT OF THE COVER

The cover applies to the stands provided to the exhibitors from the day before the opening to visitors (7.00 p.m.) to the last day of opening to visitors (closing time).

However, Plasma/LCD screen additional insurance will be effective from the morning on which the exhibition is open to the public until the evening of its closure.

B – SPECIFIC PREVENTATIVE MEASURES FOR THEFT COVERAGE.

The cover for Theft without break-in applies when the following preventive measures have been taken:

- During the hours of opening to the public and/or to exhibitors, as well as during the period of installation and dismantling, the stand must be permanently guarded by the Exhibitor or by one of its employees.
- During the hours of closure to the public and/or to exhibitors, the audiovisual equipment used for advertising purposes (such as video recorders, cameras, video cameras and portable microphones) must be stored in a locked cupboard and/or specific area.

If you fail to do so, you risk being denied coverage by the insurer.

C – PROVISIONS SPECIFIC TO OBJECTS OF VALUE

Objects in precious metals (gold, silver or platinum), precious stones, pearls, gold or silver plate, time-pieces and any objects of a small size and/or of great value must be locked up:

- During the hours of opening of the exhibition to the public: in solid showcases equipped with thick glass and locked by safety locks

- During other times (installation – closure – dismantling): in a safe approved by the insurer.

If you fail to do so, you risk being denied coverage by the insurer.

The risks of theft are only covered in the event of break-in or in the event of violence committed against the guard or guards.

III – LOSSES

A – DECLARATION OF THE LOSS

The losses must be immediately declared to the Organiser.

In addition, losses must be reported within twenty-four (24) hours, regardless of the damage, under pain of forfeiture.

Every declaration of a loss must imperatively state the date, the circumstances of the loss and the approximate amount of the damage and must be accompanied by the original filing of a complaint in the event of theft.

This claim form must be sent directly to SIACI SAINT HONORE, as indicated in section VII below.

The claim form must indicate the insurance policy number, i.e. AXA France policy no. 4 299 10 204.

B – MEASURE TO TAKE AT THE TIME OF A LOSS

You must also take any measures to ensure the protection of the undamaged objects and, when the liability of a third party can be involved, must take all the measures required by the laws and regulations in effect to protect the recourse of the insurer.

If you fail to do so, you risk being denied coverage by the insurer.

C – ASSESSMENT OF THE LOSS

It is recalled that the insurance cannot produce a profit for the insured party. It only covers the compensation for its material losses in accordance with the compensation principle stipulated by the Code in Article L 121-1.

In the event of a loss covered by the insurance policy, the damage is assessed by mutual agreement.

D – PAYMENT OF THE BENEFIT

The benefit shall be paid to the owners of the insured property.

The benefit shall be paid to the owners of the insured property. If the coverage amount applied for is insufficient, the benefit shall be divided proportionally to the total value of the damaged property of each of the exhibitors present at the stand.

IV –WAIVER OF RECOURSE

Every exhibitor, by the sole fact of its attendance, declares that it renounces any recourse that it or its insurers may have the right to exercise against the organiser and the operating company of the premises where the event takes place and their insurers, for any direct or indirect damage that the latter may cause to its goods. The insurance conditions that are the subject of these Articles are governed by the Insurance Code.

V - PERSONAL DATA

The personal data collected on the enrolment form for the above-mentioned insurance policy and during the term of the policy may be disclosed to the Insurer and to the persons involved in managing the policy (intermediate underwriters, experts and reinsurers).

Said data shall be used to manage the policy, to analyse and control risk, to carry out the services, to prepare statistics and to enforce the legal, regulatory and administrative provisions in force.

As provided by law, the insured may access the information concerning him/her, have it corrected, object to its disclosure to third parties or to its use for commercial

Payment of comprehensive insurance for exhibitions (cont.)

purposes by sending a letter to COMEXPOSIUM ASSURANCES.

VI – CONTACT DETAILS OF AND INFORMATION ABOUT THE INSURANCE BROKER

COMEXPOSIUM ASSURANCES Insurance brokerage firm registered with ORIAS under number 10 058 342 and located at
70 Avenue du Général de Gaulle
92508 Paris La Défense Cedex
Telephone: + 33 1 76 77 11 11

The registration of COMEXPOSIUM ASSURANCES can be verified at www.orias.fr.

COMEXPOSIUM ASSURANCES is subject to the control of the Autorité de Contrôle Prudentiel (ACP) located at 61 rue Taitbout - 75436 Paris Cedex 09 (Switchboard: + 33 1 55 50 41 41).

COMEXPOSIUM ASSURANCES is a subsidiary of the COMEXPOSIUM company.

COMEXPOSIUM ASSURANCES offers only property and casualty insurance policies at the exclusion of public liability and life insurance policies.

COMEXPOSIUM ASSURANCES has a civil liability guarantee and a financial guarantee in accordance with the insurance law, which it has obtained from the ALLIANZ company.

COMEXPOSIUM ASSURANCES has no financial ties to insurance companies.

To assist it in offering the above-mentioned insurance policy, COMEXPOSIUMASSURANCES has granted power to the SIAL SA company, agent intermediate underwriter registered with ORIAS under number 11061114, whose head office is located at
70 avenue du Général de Gaulle
92058 Paris la Défense Cedex.

The registration of SIAL SA can be verified at www.orias.fr.

SIAL SA is subject to the control of the Autorité de Contrôle Prudentiel (ACP) located at
61 rue Taitbout
75436 Paris Cedex 09
(Switchboard: + 33 1 55 50 41 41).

SIAL SA has no financial ties to insurance companies.

VII - CLAIM FORM

In the event of a loss, claim forms must be sent to:

SIACI SAINT HONORE 18 rue de Courcelles 75384 Paris Cedex 08 Telephone: +33 1.44.20.99.99
--

Such claim forms must meet the above-mentioned conditions and be sent by registered letter with acknowledgment of receipt.

Stand Design Regulation

Introduction

The «Architecture Regulations» of the Sial 2014 lists the norms for presentation and fitting of stands, set out in such a way as to guarantee a smooth show as well as optimal comfort.

These norms include standard applicable safety rules for trade fairs, salons and exhibitions, laid out at the end of the document. All stand fittings and decors must follow the «Architecture Regulations».

In all cases, before construction, each project must be submitted to the Sial Architecture Department, who may authorise installation on the site. Any project that does not respect the Rules will be refused, and any stand built without the approval of the Architecture Office can be taken down at the expense of the exhibitor.

No agreement made between exhibitors will be authorised; only the organiser or DECO PLUS will be permitted to grant authorisation for deviations on written request.

The projects must be submitted before the 4 July 2014 at the latest.

Your Stand Installation File will include the following commitments taken by the exhibitor and the decorator:

- The commitment form for clearance of debris from your stand on assembly and disassembly: Once assembly and disassembly has finished and the stand space has been cleared of all debris and residue, the exhibitor and the decorator must complete the Clearance Declaration for the stand space and submit it to the Exhibitor's Commissariat.

In the case where debris are left on the stand, the exhibitor and the decorator will be held responsible for any breach of commitments made in the Stand Installation File and in the commercial activity form.

The dossier will be sent to you by the Architecture Department of the SIAL by e-mail as soon as you have chosen the location for your stand. It must be returned completed and signed. This dossier includes:

For the Bare stand:

1. The Installation File for your stand, completed and signed
2. The Stand Project: «Overhead view» plans showing scales, dimensions and positions of perimeters (shared partitions + alleys)
3. «Cutaway» plans showing scales, dimensions and heights of volumes depicted

For the Fitted stand:

1. The Installation File for your stand

Any project that does not comply with French law and/or the regulations of the SIAL will be rejected and any stand assembled without the approval of the Architecture Office will be dismantled, at the expense of the exhibitor.

The SIAL architecture office
DECO PLUS
1, rue Paul Delaroche - F - 75116 PARIS
Tel.: +33 (0)1 47 63 94 84 - Fax: +33 (0)1 43 80 59 63
E-mail: sialarchi@free.fr

AMOUNT OF PENALTIES CHARGED TO THE EXHIBITOR OR THE DECORATOR

Your Questions - Our answers	PENALTY for debris left after assembly or disassembly
Who signs the commitment?	The exhibitor or the decorator
How much is the penalty? (1)	€ 1500 excl. tax for < 50 sqm € 3500 excl. tax for < 50 to 100 sqm > € 5000 excl. tax for < 100 to 250 sqm > € 7000 excl. tax for < 250 to 400 sqm > € 10000 excl. tax for > 400 sqm
if I do not return the forms for cleaning debris from my stand, what will happen?	My file will not be considered by the organiser to be complete and the plans will not be validated. Access to Exhibition Centre will not be authorised and exhibitor badges will not be issued.
Make a status report of your stand, skip rental (2)	After dismantling the stand, the exhibitor or the decorator MUST contact the Head quarter office in Hall 5A to obtain the inventory report for the exit obtain a SPACE CLEARANCE CERTIFICATE (2).
Infringements recorded on site	The record will be presented to the exhibitor on site or by letter. The penalty for the infringement will be sent in the form of an invoice.

(1) In the case of multi-installations, the amount of the penalty is calculated according to the total of the spaces concerned.

(2) The exhibitor or the decorator must make the necessary arrangements to remove debris during assembly and disassembly periods.

Where a stand is abandoned and recorded officially by the SIAL, the penalty indicated will be invoiced. In the case of an infringement that surpasses the amount of the penalty, the invoice will be made out for the real value.

CONTENTS

TECHNICAL SPECIFICATIONS

Hall specifications

- 1/ Location of SIAL 2014
- 2/ Access to the halls
- 3/ Floors, walls and pillars in the halls
- 4/ Fluid distribution conduits
- 5/ Damage
- 6/ Aisles
- 7/ Suspended items
- 8/ Smoke extraction controls and fixed fire points
- 9/ Fire points (hoses)

Supplies included in the site rental charges

- 10/ Accessibility for Persons of Reduced Mobility (PRM)
- 11/ Side panelling
- 12/ Two-sided stand sign

STAND DESIGN REGULATIONS

Height of stands, clearance limits and openings onto aisles

- 13/ Height limits
- 14/ Openings onto aisles
- 15/ Heights and recesses
- 16/ Re-used stands

Signage

- 17/ Structure
- 18/ Anchored balloons
- 19/ Sound systems and illuminated signs
- 20/ TV screens (and video walls)

Platforms and Ceilings

- 21/ Platforms
- 22/ Ceilings

Double-decker stands

- 23/ Accessibility for Persons of Reduced Mobility (PRM)
- 24/ Certificate of conformity to safety standards
- 25/ Surface area
- 26/ Weight limits
- 27/ Stairs
- 28/ Fire prevention
- 29/ Transparency for raised floors
- 30/ Ceilings

Kitchens / Food sampling

- 31/ Food sampling
- 32/ Cooking on the stands

Technical Specifications

HALL SPECIFICATIONS

1. Location of SIAL 2014

SIAL will take place in halls 1-2-3-4-5A-5B-6-7 and 8 at the Paris-Nord Villepinte Exhibition Centre from 19 to 23 October 2014.

2. Access to the halls

The halls are all on ground level. Access to the halls is provided at ground level by numerous side doors. Vehicles are not allowed to enter the halls. Car parks next to each of the halls are available to fitters during exhibition set-up and dismantling.

3. Floors, walls and pillars in the halls

Floors, walls and pillars are either made of concrete or enamelled metal or clad with wood panelling. It is forbidden to drill, cut or otherwise deface these surfaces, nor may they be painted.

4. Fluid distribution conduits

The distribution of fluids in the halls is provided by a series of conduits. The conduits are enclosed by cast iron plates which cannot be moved. Only the Exhibition Centre operating company is entitled to use these conduits.

5. Damage

Exhibitors shall be held responsible for any damage which they or their appointed contractors may cause to the building during transport, installation or removal of their equipment.

6. Aisles

Exhibitors must not obstruct aisles with pipes, cables or decorations either at ground level or above ground. However, pipes and cables which meet the requirements of SIAL or the Safety Department may be installed over stand areas if necessary.

7. Suspended items

Items suspended from the framework of the halls are installed by the Exhibition Centre's Technical Department. Requests must be made directly to the SIAL. All suspended items must comply with the SIAL 2014 Stand Design Regulations.

8. Smoke extraction controls and fixed fire points

Smoke extraction controls or fire extinguishers are mounted on the side panelling or on pillars and are indicated on the plans. Fire hoses are shown on the schemas. They must be cut away to accommodate these facilities, as shown on the drawings below. The intercoms must remain accessible at all times. Signs pointing out these facilities must be visible at all times.

9. Fire points (hoses)

Fire hoses are located on the pillars either in the middle or at the edge of the stand. They must be left completely clear as shown in the diagrams below.

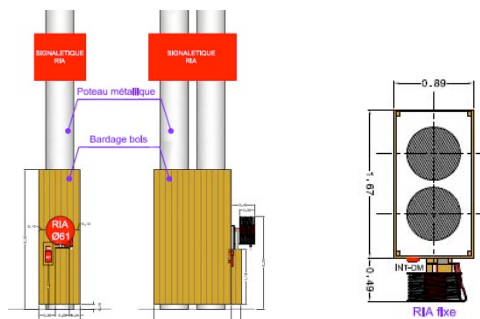
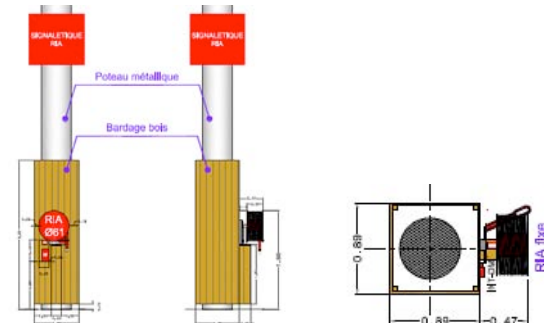

Halls 1 à 6



Hall 5B

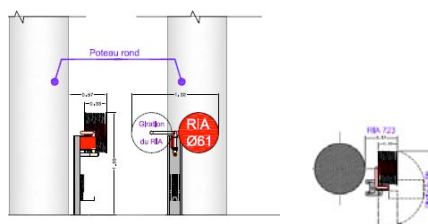

Hall 7

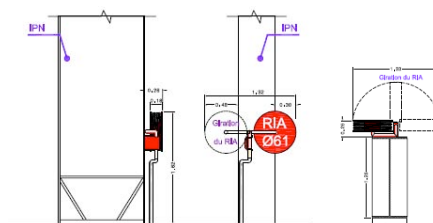

Hall 8

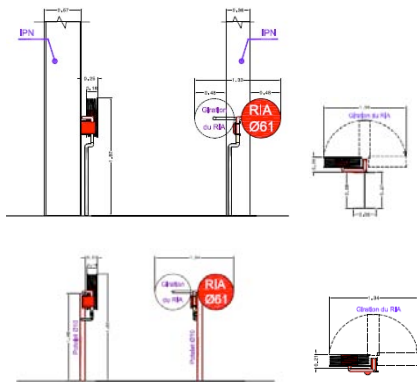

Hall 8

10. Accessibility for people of reduced mobility

In compliance with the regulations and with the Exhibitor's Guide for stands with a floor raised by over 2 cm, an access ramp is required for people of reduced mobility. These ramps must not encroach on the alleys. The access ramp should be at least 90cm wide and have a slope between 2% and 5%.

11. Side panelling

The panelling around the sides of the halls is 3 metres high. Exhibitors may use any part of the panelling to hang signs or decorations. Anything stapled to the panelling must be removed by the exhibitor at the end of the exhibition and the staples removed from the panelling. Failing this, the exhibitor will be charged for restoring it to its original condition.

12. Two-sided stand sign

SIAL will provide one sign per direct exhibitor's site. This sign on the ground features the number of your stand (except for collective stands)

Stand Design Regulation

HEIGHT OF STANDS, CLEARANCE LIMITS AND OPENINGS ONTO AISLES

Stands must be constructed taking into account the following height and clearance limits:

13. Construction heights

- Maximum authorised height of shared partitions 2.50 m from the floor of the building.
- Maximum height of the construction: 5m from the floor of the building.

No connection with neighbouring stands can be accepted.

14. Openings onto aisles

- Stand sides opening onto an aisle must include an opening of at least 2.5 metres every 4 linear metres. The opening must equate to at least half the length of the side. The 2.5m opening must be kept clear: green plants, glass panes, etc. will not be authorised.

15. Heights and recesses

Stand structures must take into account the following clearance limits:

Heights and recesses (heights are stated from the ground level of the building):

Recesses from the aisles and the neighbouring stands:

- Adjoining partitions height: 0 to 1.80 m No recess
- Partition or construction items, height: from 1.80 to 2.50 m recess 0.50 m from the aisles and the neighbouring stands. The partitions adjoining with the neighbours must start 0.50 m from the aisles.
- Partition or construction items, height: de 2.50 to 5.00 m recess 1.00 m from the aisles and the neighbouring stands.
- **CAUTION** Double Decker (Storeys) must apply a 2.00 m recess from the aisles and neighbouring stands.

For solid horizontal structures such as the floors of upper levels and solid ceilings, there must be a 2-metre clearance from the partitioning in order to leave a distance of at least 4 metres between two adjoining double-decker stands or solid ceilings. Fascias must not extend higher than 2.5 metres above the floor. If a sign or logo exceeding the 2.5 metre limit is to be fixed to the fascia, it must be the prescribed distance from the edges of the stand and dividing partitions in particular.

Stands including a hall pillar

1. Stands that include a hall pillar, with or without a fire hose, can cover it to a height of 3 m. A sign that conforms to the imposed requirements can be installed. The fire hose must remain accessible from the front and sides within a 1 m radius.

2. Pillars positioned half on a stand and half on a walkway may be covered up to a height of 3 m with the stand's sign.

Stands that back on to the hall stairs

1. The side facing the stairs should be considered as an open side. This side of the stand must not surpass the height of the stairs, without exceeding 1 m.

16. Re-used stands

These are subject to SIAL's Stand Design Regulations in the same way as newly built stands. They must conform to the prescribed clearance and height limits.

SIGN / LIGHT TRUSSES

17. Structure

- By sign structure, the organizers mean an open-work superstructure which can include the illuminated name or logo of the exhibitor.
- The heights are limited to 5.00 m and the positioning of the sign/truss must be positioned at the level between 2.50 and 5.00 m and in accordance with the recesses.
- The free standing structures will have to respect 1.00 m setback from the aisles and the neighboring stands.
- Hanging of framework, this work may be carried out only by the Technical Department of the Exhibition Centre. Point suspension on a 3.00 m x 3.00 m grid. Permitted weight: 80 kg per point for overall occupancy. Beyond 80 kg, on request to Paris Nord Villepinte. The order of the suspension will be allowed up to 5.50 m and no exception will be given.

18. Anchored balloons

Balloons inflated with a gas lighter than air, used as signs, must not exceed the prescribed height and clearance limits. Anchoring ties must be maintained at a constant length. Failure to comply with this requirement will give SIAL the right to remove them.

19. Sound systems and illuminated signs

Any advertising using lighting or sound must be submitted to the approval of SIAL, who may withdraw such permission once granted if the item in question causes a nuisance to neighbouring exhibitors, causes an obstruction or mars the appearance of the exhibition. Flashing signs and the like are not permitted. Illuminated signs are permitted but they must under no circumstances be of an intermittent or flashing nature.

20. TV screens (and video walls)

TV screens making up a video wall up to 5 metres high are regarded as flashing signs and are forbidden unless they are set back from the aisle by 2 metres. The sound level is restricted to 80 dbA.

PLATFORMS AND CEILINGS

21. Platforms

Stands including platforms or of split-level design (assuming the interior space is not used and the prescribed height limits are observed) must conform to specific guidelines supplied on request.

22. Ceilings

As a general rule, solid ceilings are not permitted at SIAL. However, the following stand roofing options are permitted:

- Cellular structures of the "Claustra" type made of M0 or M1 materials
- Alternating structures made of M0 or M1 materials laid out in "checkerboard" form to provide a largely open-work ceiling (50%).
- Vertical strips made of thin M0 or M1 materials placed at least 0.2 metres apart.

23. Accessibility for people with reduced mobility

In compliance with the regulations and with the Exhibitor's Guide for stands with a floor raised by over 2cm, an access ramp is required for people of reduced mobility. These ramps must not encroach on the alleys.

The ramps should be at least 0.90 m wide and the slope must be between 2 and 5 %.

DOUBLE-DECKER STANDS

Exhibitors wishing to build a double-decker stand must apply for permission to build by 4 July 2014 at the latest. The application must be accompanied by a cheque for € 135 excl. VAT per sqm of additional floor space. This sum will be deducted from the final building fees once SIAL's Design Department has carried out the final calculation of the area and granted permission to build.

24. Certificate of conformity to safety standards

As soon as they have received building permission, exhibitors should draw up their plans, taking into account the surface area allocated, and send them to the SIAL Design Department which will confirm its final approval and forward copies to the Safety Department. Detailed plans of both stands and upper levels should therefore be submitted for approval in duplicate. The plans should take into account the requirements concerning height and clearance limits contained in Articles 14, 15, 16 and following.

IMPORTANT

For solid horizontal structures such as the floors of upper levels and solid ceilings, there must be a 2-metre clearance from the partitioning in order to leave a distance of at least 4 metres between two adjoining double-decker stands or solid ceilings. Fascias must not extend higher than 2.5 metres above the floor. If a sign or logo exceeding the 2.5 metre limit is to be fixed to the fascia, it must be the prescribed distance from the edges of the stand and dividing partitions in particular.

25. Surface area

300 sqm maximum for the upper level itself. Only one upper level per stand is permitted.

26. Weight limits

- 250 Kg/m² for upper levels under 50 m².
- 350 Kg/m² for upper levels over 50 m².

IMPORTANT

Exhibitors shall produce their calculations for their double-decker stand and have them checked during build-up by a registered inspector. The security consultancy DECO PLUS Tel.: + 33 (0)1 47 63 94 84 E-mail: sialarchi@free.fr can provide on request a list of registered inspectors in the Paris area. It is imperative that these documents are presented to the Safety Committee when they inspect the stand to approve the upper level for opening to the public.

27. Stairs

Number of staircases per upper level and minimum width:

Careful consideration must be given to the exact position of staircases leading to upper levels, their number and width being dependent on the surface area of such levels:

- Up to 19 m²: 1 x 0.90-metres staircase
- 20-50 m²: 2 staircases, one 0.9 metres wide and the other 0.6 metre wide
- 51-100 m²: either 2 x 0.9-metre staircases or 2 staircases, one 1.4 metres wide and the other 0.6 metre wide
- 101-200 m²: 2 staircases, one 1.4 metres wide and the other 0.9 metre wide
- 201-300 m²: 2 x 1.4-metre staircases. Only staircases whose closest outer uprights are at least 5 metres apart can be taken into account in the number of exits and stair widths. Exits must be clearly pointed out by a sign bearing the word "Sortie" (exit) in white letters on a green background.

Straight staircases

Straight staircases for public use must be constructed such that the steps comply with the customary regulations, each flight of stairs having no more than 25 steps. As far as possible, the direction of the flights should alternate. The height of the steps must be 13 cm minimum and 17 cm maximum.

Steps must be at least 28 cm but not more than 36 cm wide.

The relationship between the height and width of steps is governed by the equation $0.60 < 2H + G < 0.64$ m. The steps in one flight must be of uniform height and width, although an exception may be made for the first step. Landings should be the same width as the staircase: in the case of flights not continuing in a different direction, landings should be longer than one metre. Single-width staircases must be fitted with one handrail. Double-width staircases or wider must have one handrail on each side.

Spiral staircases

Standard or additional spiral staircases shall be continuous, with no other landings apart from those serving upper levels. The tread and the height of the steps on the line of flight, 0.6 metre from the newel or central void, shall conform to the regulations mentioned in the previous article. In addition, the outer stair tread must not exceed 0.42 metre. The handrail for single-width staircases must be located on the outside.

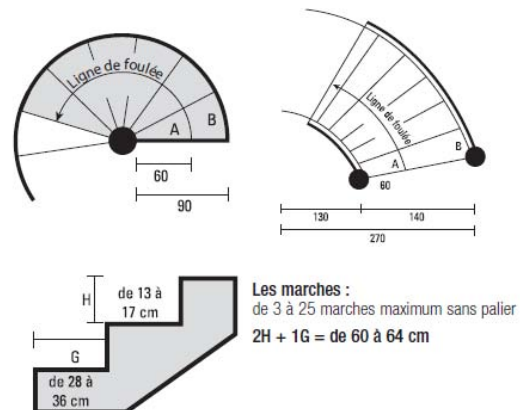

Stairs

- Single-width: $A > 28$ cm / $B < 42$ cm.
- Double-width: $A > 28$ cm / $B < 42$ cm.

Stairs combining straight and spiral elements.

On condition that both the spiral and straight elements conform to the aforementioned regulations, staircases of this type can be considered as complying with the regulations defined above and, consequently, nothing prevents their being used in establishments open to the public.

Stand Design Regulation (cont.)

Stair railings and banisters

In accordance with French standards NF P 01-012 and NF P 01-013, stair railings must withstand a pressure of 100 kg per linear metre. Protective glass panels must be either reinforced or made of compound glass. So-called "Securit" glass is not permitted.

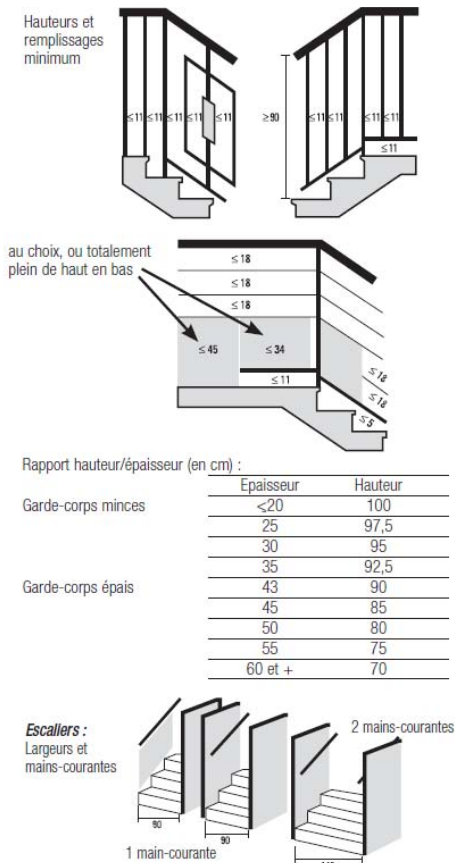

Location

Stairs must be located at least 1 metre from the stand's common partitioning in order to avoid overlooking the neighbouring stand. When two staircases are necessary, they shall be diametrically opposed.

28. Fire prevention

Each stand shall be equipped with fire extinguishing facilities, including: one sprayed water extinguisher placed at the bottom of each staircase and a CO2-type extinguisher placed near the electricity switchboard. If the surface area of the upper level is greater than 50 m², appropriate additional fire extinguishing facilities shall be constantly ensured by at least one safety officer while the public is present.

29. Transparent upper levels

Upper levels may be used to display a sign while remaining open-work. Not more than half the sides of the upper level may be filled in. The parts of sides left open shall be fitted with guard-rails in compliance with safety regulations. (French standard pertaining to guard-rails: NFP 01-012).

30. Ceilings

Upper levels must not be covered with a solid ceiling or canopy.

KITCHENS - FOOD SAMPLING

31. Food sampling

Tasting alongside the aisles is expressly forbidden.

If the exhibitor intends to provide samples for tasting, this must be done inside the stand.

32. Cooking on the stands

Exhibitors wishing to prepare cooked food on their stands must inform SIAL by 11 July 2014. They must also:

- Take all necessary steps to avoid environmental pollution.
- Conform to the safety standards (particularly with respect to the use of liquid gas (Article 45) and hygiene regulations in force.
- Provide areas where meals can be served out of sight of visitors circulating in the aisles.

You will find the declaration form at www.sialparis.fr in your Exhibitors Area > My forms

In all kitchens:

- The floor (or the table) supporting cooking appliances must be made of non-combustible material or covered with M0-class material
- Cooking appliances must be kept at a suitable distance from any combustible material and installed in such a way as to prevent any danger of fire
- If such devices are located near a partition, M0 surfacing must be provided up to a height of 1 metre to the right of the device
- Electric meters must be positioned at least 1 metre from any water outlet
- Every installation must be equipped with 1 or more extinguishers.

Cooking and heating appliances with a normal power rating of less than 20 kW are permitted inside exhibition halls. However, please respect the following conditions:

- filters must be placed above cooking appliances;
- cooking and heating appliances must not pose any risk to the public;
- appropriate safety measures must be in place (extinguishers)

Cooking and heating appliances with a normal power rating greater than 20 kW for the whole stand are permitted inside exhibition halls. However, please respect the following conditions:

- inner and outer walls must have a fire-resistance rating of 1 hour (French regulations)
- doors opening onto the stand should be PF 1/2 hour or E 30 (door mandatory)
- a distance of 4 metres must be maintained between each kitchen unit
- flame-retardant screens must be placed around cooking appliances
- if opening onto the stand:
 - possess a fixed vertical screen that is fire stable in 1/4 hour or E 1S-S and in a material with a fire classification of M1 or A2-S1, d1 and be of a minimum height of 0.5m underneath the finished kitchen ceiling.
 - include a cooker hood and ventilation duct in MO or A0-S1, d0 material, the extractor fan should function for 1 hour with smoke at 400°C
- the main fuse box should be fitted with an emergency cut-out switch
- cooking or reheating appliances should have the CE label
- emergency equipment should be to hand (appropriate extinguishers)
- Cooking and reheating appliances that give off water vapour can be used without a filter, but other appliances that emit other substances (grease, etc.) must have an overhead hood filter, and all combustion equipment (gas) must have an outside outlet for exhaust.

PKL-style portable container kitchens are permitted if they use extraction systems.

Mobile kitchens in containers (PKL-style) can be installed using the same extraction fittings.

Stands with cooking appliances with a combined wattage of less than 20 kW (See form on www.sialparis.fr, Exhibitors services)

- Each kitchen must have an extractor hood covering all the cooking appliances
- Each kitchen must have a central cut-off for all the cooking appliances (if necessary, one for the gas supply and one for the electricity supply). The cut-off devices must be clearly marked and easily accessible
- Cooking appliances must either be installed at least 0.5 metre from the walls of the kitchen or the walls must be insulated with fireproof material
- Flexible gas pipes connecting appliances to the gas supply must be replaced at the appropriate time
- A mandatory certificate relating to the total power of appliances installed must be presented to the Safety Committee.

Characteristics of cooker hoods

The health regulations relating to the extraction of water vapour and oily steam calls for the provision of mechanical extractor devices. All steam and smoke must be drawn into a large hood by a sufficiently powerful fan, then filtered and deodorized by three successive filters: the first a fine wire mesh, the second an electrostatic finishing filter and the third a deodorizing activated carbon filter.

- The crosssection of the filters must be approximately 0.5 metre per square metre of cooking space
- The rate of extraction must be approximately 4,000 m³/hour per square metre of cooking space
- The hood must be closed on three sides, with a clearance of 0.8 metre above the cooking area.

Safety & Fire Regulations

1. OVERVIEW

Safety rules regarding risks of fire and panic in establishments open to the public have been established by the Order dated June 25th, 1980 (general provisions). The Order dated November 18th, 1987 sets forth the specific provisions applicable to exhibition halls.

The text below is excerpted from said regulations in order to facilitate understanding.

The Safety Board is quite severe regarding stand construction (stability, construction and decoration materials, electrical installations, etc.). The decisions made during Safety Board inspections, the day before or the morning the event opens must be immediately implemented. Stand installation must be completed for Safety Board inspections.

The exhibitor (or his representative) must be present at the stand and be prepared to provide flammability reports for all materials used. Non-compliance with this rule may lead to the removal of such materials or a prohibition on opening the stand to the public.

All large projects (> 40 m²) must be submitted to the trade show's Safety Supervisor for approval. Drawings and technical information must be submitted to the organizer at least one month before the trade show opens.

During the assembly period, the Safety Supervisor shall monitor application of the safety rules indicated hereinafter. Moreover, all information regarding fire safety may be obtained by calling:

Mr Philippe WATTEAU
Tel.: +33 (0)6 85 94 49 57
(Business days, from 9.00 am to 6.00 pm)
Fax: +33 (0)1 70 10 40 11
Email: philippewatteau@numericable.fr

MATERIAL FIRE CLASSIFICATION (Order dated June 30th, 1983) : materials are classed under 5 categories: M0, M1, M2, M3, and M4. M0 indicates non-flammable materials.

2. STAND FITTING-OUT

2.1 – Stand framework and partitions – Large furniture

All materials classed M0, M1, M2, and M3(1) shall be permitted for stand framework and partition construction and for building large furnishing (crates, counters, display stands, separation screens, etc.)

Conventional classification for wooden materials (Order dated June 30th, 1983)

The following shall be deemed to have the characteristics of M3 class materials:

- solid non-resinous wood whose thickness is greater than or equal to 14 mm,
- solid resinous wood whose thickness is greater than or equal to 18 mm,
- wood-derivative panels (plywood, lath, fibreboard, particleboard) whose thickness is greater than or equal to 18 mm.

N.B.: It is absolutely prohibited to place any facilities above the alleyways (structure or fascia band, bridge, etc.)

2.2 - Surfacing Materials

2.2.1 - Wall Surfacing

Wall surfacing (natural textiles or plastics) must be composed of M0, M1, or M2 (1) class materials. They may be stretched or attached with clips. Various very thin (1 mm max.) surfacing (fabric, paper, plastic films) may be used bonded directly on M0, M1, M2, or M3 material support surfaces. However, embossed or relief paper must be bonded directly to M0 materials only. Exhibited materials may be presented in the stands without required fire-reaction testing.

Nevertheless, if said materials are used for decorating partitions or fake ceilings, and if they represent more than 20% of the total surface of said elements, the provisions contained in the preceding paragraphs shall apply to them. However, said provisions shall not apply to trade shows and stands specifically for interior decoration in which textiles and wall surfacing are presented.

(1) Or made so by fireproofing

2.2.2 - Curtains - Wall Hangings - Sheer Curtains

Curtains, wall hangings, and sheer curtains may be free-hanging if they are class M0, M1, or M2. They are, however, prohibited on stand entrance and exit doors, but authorized on cabin doors.

2.2.3 - Paints and Varnishes

Paints and varnishes are strictly prohibited if they are deemed flammable (e.g. nitrocellulose or glycerol-phtalic)

2.2.4 - Floor, Podium, Stage, and Tier Surfacing

Floor surfacing must be composed of M4 class materials and solidly attached. Surfacing, whether horizontal or not, of podiums, stages, and tiers higher than 0.3 m and total surface area greater than 20 m² must be constructed of M3 class materials. If their total surface area is less than or equal to 20 m² said surfacing may be constructed in M4 class materials.

N.B.: for M3 or M4 class carpets on wood, factor in the attachment method. Fire reaction testing data must include the statement: "Valid for stretched laying on M3 class supports."

2.3 - Decorative Elements

2.3.1 - Free-Hanging Elements

Decorative elements or free-hanging decor panels (advertising panels with a surface area greater than 0.5 m², garlands, light decorative items, etc.) must be composed of M0 or M1 class materials.

The use of signs and advertising containing white letters on a green background is strictly prohibited, as said colours are exclusively reserved for indicating exits and emergency exits.

2.3.2 - Floral Decorations

Floral decorations and synthetic materials must be limited. If not, said decorations must be produced using M2 class materials. The present provisions shall not apply to trade shows and stands specific to floral activities

N.B.: For natural plants, give preference to the use of peat humus which must be kept damp at all times.

2.3.3 - Furniture

There are no requirements for common furniture (chairs, tables, desks, etc.). However, crates, counters, shelving, etc. must be composed of M3 (1) materials.

2.4 - Canopies - Ceilings - Suspended Ceilings

Stands with ceilings, suspended ceilings, or full canopies must have a covered surface area less than 300 m². Should the covered surface area be greater than 50 m², the

appropriate fire suppression systems manned continuously by at least one safety agent must be provided during times when the public is present.

2.4.1- Canopies

Canopies shall be authorized under the following conditions:

- in establishments protected by an automatic water based fire suppression system (2), the canopies must be composed of M0, M1, or M2 (1) materials,
- in establishments not protected by an automatic water based fire suppression system, they must be composed of M0 or M1 class materials.

In addition, they must have an effective hanging system preventing them from falling and be supported by a system of crosswires with a maximum mesh size of 1 m². In all cases, ceiling and suspended ceiling suspension and attachment must use M0 class materials. When insulation is placed in the ceiling or suspended ceiling plenum, it must be composed of M1 class materials.

2.4.2 - Ceilings and Suspended Ceilings

Ceilings and suspended ceilings must be composed of M0 or M1 class materials.

Nevertheless, 25% of the total surface area of ceilings and suspended ceilings may be composed of M2 class materials. Lighting fixtures and accessories shall be included in said percentage. Moreover, should the ceiling and suspended ceiling component elements be perforated or netted, they may be composed of M2 class materials where the solid surface is less than 50% of the total surface area of such ceilings and suspended ceilings.

2.5 – Handicapped Person Access

Installing a floor pan on the ground whose thickness is greater than 7 mm requires it to be equipped around its entire perimeter with a slope whose depth shall be equal to twice its height (i.e.: for a 2 cm thick floor pan, the slope shall have a 4 cm depth). This point shall constitute dispense for the creation of an ambulant disabled persons' entrance for floor pans up to 4 cm thick. Beyond this thickness, in addition, all floors where the public may go must include an integrated ambulant disabled persons ramp, which may not impinge upon the travel circuits. It must be 0.9 m wide with a slope between 2% and 5%.

2.6 – Fireproofing

Proof of fire reaction classification for the materials used in the exhibition halls must be provided upon request to the Safety Supervisor in the form of labels, reports, and certificates.

Surfacing and materials fulfilling the safety requirements are available for purchase from specialized merchants who must provide certificates corresponding to material classification.

To obtain a list of such merchants, contact:

GROUPEMENT NON FEU, 37-39, rue de Neuilly
BP 249, 92113 Clichy (Tel.: +33 (0)1 47 56 30 81)

Fireproofing must achieve M2 quality for materials which, in their normal state, are moderately or easily flammable. This may be accomplished by spraying a special liquid, by applying a special paint or varnish with a brush, or by soaking an a special bath. Fireproofing must be performed either by decorators, who must be capable of providing information regarding material processing or by an approved applicator, who shall provide the exhibitor with an approved certificate including the following information: type, surface area, and colour of the treated surfacing, the product used, operation date, as well as the operator's stamp and signature. Contact information for approved applicators may be obtained from:

GROUPEMENT TECHNIQUE FRANCAIS DE
L'IGNIFUGATION

10, rue du Débarcadère, 75017 PARIS
Tel.: +33 (0)1 40 55 13 13

(2) This is the case of Halls 5 and 6 at the Parc d'Expositions de Paris Nord Villepinte

N.B.: Fireproofing may only be applied to wooden panels or natural fabrics or those with a significant proportion of natural fibres. It is not possible for synthetic fabrics or plastics.

VERY IMPORTANT:

Original foreign reports may not be used. Only reports from approved French laboratories shall be accepted (Euroclass classification table at the end of the present rules)

2.7 – Exterior Stands and Marquees, Tents, and Structures

Any building or constructions located outside the Halls must have a case file indicating site location, dimensioned drawings of the construction with surface area, number of levels, etc.

This file must be submitted for approval to the Security Supervisor at least two months before the event.

In some cases, smoke evacuation, verification of assembly-solidity-stability, and a verification of electrical facilities by an approved body may be requested.

Marquee, tent, structure definition: A closed, itinerant establishment with a flexible cover, for various uses.

This type of establishment must have an attestation of conformity delivered by a Marquee, Tent, and Structure Verification Office. Contact the Security Supervisor (Cabinet Watteau) for information regarding the steps to take.

3 – ELECTRICITY

3.1 - Electrical Facilities

The electrical facilities for each stand must be integrally protected against surcharges and ground faults. All metal grounds must be interconnected and connected to the stand's electrical switch board ground. Electrical connections must be made inside connection housings. Electricity cut-off systems must be continuously accessible to stand staff.

3.2 - Electrical Equipment

3.2.1 - Electric Wiring

Electric wiring must be insulated for a minimum of 500 V, which prohibits the use of H-03-VHH (scindex) wiring. Use only wiring for which each conductor has its own protective sheath, with all conductors housed in a single protective sheath.

3.2.2 – Conductors

The use of conductors with a cross-section less than 1.5 mm² is prohibited.

3.2.3 - Electric Devices

Class 0 (3) electric devices must be protected by nominal differential current systems of at least 30 MA.

Class I (3) electric devices must be connected to the protective conductor in their supply line.

For Class II (3) electric devices, those bearing the symbol are recommended.

3.2.4 - Multi-sockets

Only fixed-based multi-sockets or adapters are allowed (moulded multi-sockets)

3.2.5 - Halogen bulbs (EN 60598 standard)

Lighting fixtures containing halogen bulbs must be:

- placed at a height of at least 2.25 m,

- kept away from flammable materials (at least 0.5 m from wood and other decorative materials),
- solidly attached,
- equipped with safety screens (glass or fine mesh) providing protection against the effects of exploding blubs.

3.2.6 - High-Voltage Lighted Signs

High-voltage lighted signs within reach of the public or stand staff must be protected, in particular the electrodes, by a screen of M3 class material or better. The cut-off switch must be indicated and transformers placed in a spot that does not pose a danger to people. Their presence may be indicated with a sign "Danger, High Voltage."

(3) as defined in standard NF C 20-030

4 - CLOSED STANDS - ROOMS SETUP IN THE HALLS

4.1 - Closed Stands

Some exhibitors may prefer to be isolated in closed stands. Such stands must comply with decoration rules on page 23 Article 5 and must have direct exits to travel ways. Their number and size shall be based on stand surface area, i.e.:

- Less than 20 m²: one 0.9 m exit
- from 20 to 50 m²: 2 exits, one 0.9 m, the other 0.6 m
- from 51 to 100 m²: either two 0.9 m exits or 2 exits, one 1.4 m, the other 0.6 m
- from 101 to 200 m²: either two exits, one 1.4 m, the other 0.9 m, or three 0.9 m exits

Exits must be evenly distributed (1 every 6 m) and on opposite sides if possible. Each of them must be indicated with an "Exit" sign in clearly visible white letters on a green background. If the stand is closed with doors, they must open outwards, with no locking system, and without swinging into traffic.

4.2 - Rooms Setup in the Halls

Independently of surfaces reserved for exhibition, meeting rooms, restaurants, movie theatres, or presentation rooms with stages or tiers, etc. may be setup.

Platforms and tiers for standing must have a resistance of 600 kilos per m². Platforms and tiers with seats must have a resistance of 400 kilos per m².

Stairs accessing tiers must have a height of at least 0.1 m and at most 0.2 m with a going of at least 0.2 m. In this case flights of stairs are limited to 10 and nose alignment must not exceed 45°.

As each case is specific, a detailed drawing must be submitted to the Safety Supervisor who shall define the measures to be applied.

5 – RAISED LEVELS

5.1 - General Remarks

In accordance with standard NF P 06-001, raised level facilities must be sufficiently solid to resist weights of:

- for levels of less than 50 m² surface area: 250 kilos per m²,
- for levels of 50 m² and over: 350 kilos per m².

Under no circumstances may raised levels be covered.

N.B.: The method for calculating weights or floor resistance certification must be submitted to the trade show Safety Supervisor during the assembly period.

In addition, a certificate from an approved organization must certify stand stability.

In addition, an approved organization must verify the stability of all raised levels.

Piercing resistance must not be greater than that permitted in the relevant site. Each stand may only have one raised level. Its surface area must be less than 300 m². Each stand must be equipped with fire suppression systems, i.e.: a water spray extinguisher, placed at the bottom of each stairway and a CO₂ extinguisher located near the electrical switchboard. Should the raised level be greater than 50 m², the appropriate supplemental fire suppression means must be manned by at least one safety agent at all times when the public is present.

5.2 – Entrances and Exits

Raised levels must be served by evenly distributed stairs, whose number and width shall be based on the surface area of said levels, i.e.:

- up to 19 m²: one 0.9 m stairway,
- from 20 to 50 m²: 2 stairways: one 0.9 m, the other 0.6 m,
- from 51 to 100 m²: either two 0.9 stairways, or two stairways one 1.4 m and the other 0.6 m,
- from 101 to 200 m²: 2 stairways, one 1.4 m, the other 0.9 m,
- from 201 to 300 m²: two 1.4 m stairways.

Only stairways separated by at least 5 metres shall be taken into account.

Exits must be indicated with an "Exit" sign in clearly visible white letters on a green background.

5.3 – Straight Stairs

Straight stairs for public circulation must be constructed such that the steps comply with professional standards and flights have no more than 25 steps. In so far as possible, flights must be in opposite directions.

Step height must be between at least 13 cm and 17 cm at most; width must be at least 28 cm and 36 cm at most. Step height and width must be related as follows: $0.6 \text{ m} < 2 H + G < 0.64 \text{ m}$.

Said heights and widths must be regular in the same flight, although this is not required for the first step. Landings must be of the same width as the stairs; for flights in the same direction, landing length must be greater than one metre. Stairways whose width is at least one passage unit wide must have a handrail (passage unit = 0.9 m) Those whose width is two passage units or greater must have a handrail on each side.

5.4 – Spiral Stairs

Normal or supplementary spiral stairs must have a continuous curve, without landings other than at floors. Step going and height in the stride line, 0.6 m from the core or central gap, must comply with professional standards as indicated in the preceding Article.

Moreover, step exterior going must be less than 0.42 m.

For stairs with a single passage unit, the handrail must be located on the outer edge.

5.5 - Stairs with Straight and Spiral Sections

In so far as a stairway complies, in its various straight and spiral sections, with the professional standards defined in paragraphs 5.3 and 5.4 hereinabove, said stairway shall be deemed in compliance with regulations and may be used in establishments open to the public.

5.6 - Guardrails and Stairway Ramps

In accordance with standards NF P 01-012 and NF P 01-013, guardrails must resist thrust of 100 kilos per linear metre.

Glass panels used as protection must be reinforced or ply glass.

So called "securit" glass is prohibited.

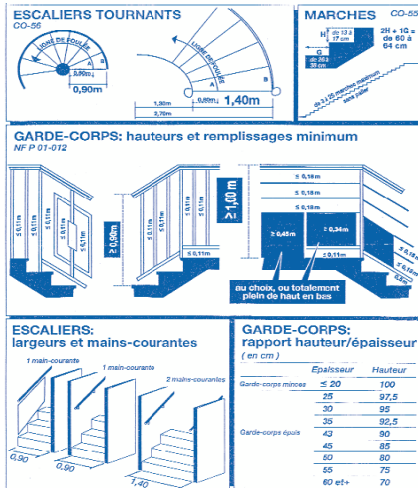

6 - LIQUEFIED GASES

6.1 - General Remarks

Bottles of gas, butane or propane, shall be allowed up to one 13 kilo bottle at most for every 10 m² of stand with a maximum of six per stand. The following measures must be taken:

- There must be at least 5 metres of space between two bottles, unless they are separated by a rigid, non-combustible, 1 cm thick screen.
- No bottle, empty or full, must remain within the exhibition hall if it is not connected to a working line.
- Bottles must be connected to the device by a standard-compliant flexible hose.

Such hoses must:

- be replaced at their expiration date,
- be appropriate in connector diameter and equipped with clamping collars,
- not exceed 2 metres in length,
- be inspectable for their entire length and move freely without clamping,
- not be reachable by burner flames or by combustion products.

6.2 - Device Supply

If, exceptionally, a bottle is to supply several devices, tubing must be made of metal (copper or steel). Using solder for connections is prohibited.

Bottles must always be placed upright and the cut-off valve must remain accessible in all circumstances. All closed-in areas where they are stored must include, on the top and bottom, air vents placed so as not to be blocked by a wall, furniture, or a neighbouring device.

6.3 - Installing Cooking Equipment

In addition to the abovementioned rules, the following measures must be taken:

- The floor (or table) supporting the cooking equipment must be composed of non-combustible material or surfaced with M0 materials.
- Cooking equipment must be kept at an appropriate distance from any combustible material and be installed so as to prevent any fire danger.
- If such devices are located near a partition, M0 surfacing must be provided up to a height of one metre beside the device.
- Hood vents must be installed above devices producing emanations or condensation.
- Electricity metres must be at least one metre from water faucets.
- Each facility must:
 - have safety instructions (steps to take in case of fire, numbers for emergency services...)
 - be equipped with one or more extinguishers.

7 - OPERATING EQUIPMENT - INTERNAL COMBUSTION ENGINES

Every machine presented in operation during the trade show must be declared beforehand, at least one month before the event opens. Only installations that have been declared may be authorized.

All equipment must be correctly stabilized to avoid risks of overturning. All protective measures must be fully completed when the Safety Board passes for inspection. A person in a position of authority must be present at the stand at this time.

No machine may be started or presented operational without qualified personnel present at the stand. All presentations and demonstrations shall be conducted under the Exhibitor's sole responsibility.

The electrical power supply shall be suspended, at the relevant exhibitor's expense, to any stand where machines in operation

present a danger to the public and for which no measures have been taken to eliminate them.

7.1 - Equipment Presented in Operation at a Permanent Station

Equipment presented in operation at a permanent station must include appropriate permanent screens or casings, preventing the public from accessing dangerous parts, or be placed such that the dangerous parts are kept away from the public, and at the least, at a distance of one metre from traffic circuits.

7.2 - Equipment Presented in Movement

Where equipment is presented in movement, a protected area must be set aside so that the public may not approach closer than one meter - said distance may be increased given the characteristics of the equipment presented. These provisions shall be valid for all stands, including those in the open air.

7.3 - Equipment with Hydraulic Cylinders

If equipment with hydraulic cylinders is exposed in stationary extended position, hydraulic safeties must be supplemented by a mechanical system preventing any unexpected retraction.

7.4 - Internal Combustion Engines

Approval for the use of internal combustion engines must be requested beforehand at least 30 days before the event opens. Such request, on plain paper (to be attached to the declaration for the machine or device in operation included in the appendix), must specify the type and daily quantity of fuel used and be accompanied by the device's descriptive leaflet, and a drawing of the device's installation on the stand.

No device of this type may be started if the authorization request was not submitted on time.

WARNING: in any case, combustion gases must be evacuated outside the halls.

8 - FLAMMABLE LIQUIDS

8.1 - General Remarks

The use of flammable liquids shall be limited to the following quantities per stand:

- 10 litres of category 2 flammable liquids for every 10 m² of stand, with a maximum of 80 litres,
- 5 litres of category 1 flammable liquids. The use of particularly flammable liquids (carbon disulphide, ethylene oxide, etc.) is prohibited. The following measures must be taken:
 - place a receptacle under the tanks or containers capable of holding all the liquid,
 - refill the device outside the presence of the public,
 - place the appropriate extinguishers nearby.

8.2 - Exhibiting Automobiles inside the Halls

Exhibiting automobiles or other vehicles shall be permitted within the halls if they have a direct relationship to the exhibition. Installing "stand" semi-trailers or similar is prohibited. The gas tanks for motors presented stopped must be empty or equipped with locked caps. Accumulator battery terminals must be protected so as to be inaccessible.

8.3 - Presenting Flammable Products

All containers for flammable liquids presented on the stands (paint or varnish cans, bottles, aerosol cans, etc.) must be empty except for a few samples in limited quantity for demonstrations.

8.4 - Prohibited Materials, Products, Gases

Air, nitrogen, and carbon dioxide gas bottles shall be permitted without restriction.

8.4.1 - The following shall be prohibited in the exhibition halls (pursuant to Article T45 of the safety regulations)

- distributing samples or products containing flammable gas;
- balloons inflated with flammable or toxic gas;
- celluloid items;
- the presence of pyrotechnics or explosives;
- the presence of ethylene oxide, carbon disulphide, ethyl ether, or acetone.

8.4.2 - The use of acetylene, oxygen, hydrogen, or a gas presenting the same risks is prohibited, unless a specific waiver is granted by the appropriate administrative authority (Prefecture, Safety Board).

Contact the Safety Supervisor
Cabinet Watteau

Tel. : +33 (0)6 85 94 49 57

Fax: +33 (0)1 70 10 40 11

Email: philippewatteau@numericable.fr

at least one month before the start of the event for the required regulatory administrative procedure.

WARNING: storage of empty of full bottles shall not be tolerated within the Halls.

8.5 - Smoke Production

Approval for the use of smoke machines to create fog or lighting effects must be requested from the administrative authority (Prefecture, Safety Board) at least one month before the start of the event. Contact the Safety Supervisor for information regarding the required administrative procedures regarding this request. Such request, on plain paper (to be attached to the declaration for the machine or device in operation included in the appendix), must specify the type and daily quantity of gas used, and be accompanied by the device's descriptive leaflet and a drawing of the device's installation on the stand. No device of this type may be started if the authorization request was not submitted on time.

9 - RADIOACTIVE SUBSTANCES - X-RAYS

9.1 - Radioactive Substances

Authorization to present radioactive substances on exhibit stands may only be granted for demonstrating devices and where substance radioactivity is less than:

- 37 kilobecquerels (1 microcurie) for those composed of Group I (4) radioelements,
- 370 kilobecquerels (10 microcuries) for those composed of Group II (4) radioelements,
- 3,700 kilobecquerels (100 microcuries) for those composed of Group III (4) radioelements.

Waivers may be granted for the use of substances with higher activity subject to the following measures:

- radioactive substances must be effectively protected,
- their presence must be indicated using the ionisation radiation schematics defined in standard NF M 60-101, as well as their type and radioactivity,

- their removal by the public must be made materially impossible either by attachment to a device requiring the use of a tool to remove or by distance,
- they must be under constant surveillance by one or more exhibitors designated by name. When such surveillance ends, even in the absence of the public, the radioactive substances must be stored in a fireproof container, bearing very clearly the conventional symbol for ionizing radiation,
- the equivalent dose rate, at all points in the stand, must remain under 7.5 micro-sieverts per hour (0.75 millirad equivalent in man per hour).

Approval (or a waiver) for the use of radioactive substances must be requested from the administrative authority (Prefecture, Security Board) at least one month before the beginning of the event.

Contact the Safety Supervisor for information regarding the required administrative procedures regarding this request. Such request, on plain paper (to be attached to the declaration for the machine or device in operation included in the appendix), must specify the type and radioactivity of the substances and the group to which they belong, the name and title of the persons responsible for their surveillance and be accompanied by the device's descriptive leaflet, a drawing of the device's installation on the stand and a document drawn up and signed by the installer certifying compliance with the present provisions. No device of this type may be started if the authorization request was not submitted on time.

WARNING: stands where radioactive substances are presented must be built and decorated with M1 class materials.

9.2 - X-rays

Authorization to present devices emitting X-rays on the stands may only be granted if they and their accessories comply with the rules set forth in standard NF C 74-100.

In particular, the following measures must be taken:

- removing superfluous objects from around the x-ray generator and the sample to be examined,
- materializing and signposting the area not accessible to the public,
- the leakage exposure rate must not exceed 0.258 micro coulomb per kilo and per hour (1 milliroentgen per hour) at a distance of 0.10 m x-ray generator core.

Approval for the use of x-ray machines must be requested from the administrative authority (Prefecture, Safety Board) at least one month before the start of the event.

Contact the Safety Supervisor for information regarding the required administrative procedures regarding this request. Such request, on plain paper (to be attached to the declaration for the machine or device in operation included in the appendix), must be accompanied by the device's descriptive leaflet, a drawing of the device's installation on the stand, and a document drawn up and signed by the installer certifying compliance with the present provisions.

No device of this type may be started if the authorization request was not submitted on time.

(4) Radioactive element classification, based on relative radio-toxicity, shall be that defined in Decree no. 66-450 dated June 20th, 1966 regarding the general principles of protection against ionizing radiation.

Autorité de Sureté Nucléaire (ASN)
6, place du Colonel Bourgoïn
75572 Paris Cedex 12
Tel: +33 (0) 1 43 19 70 75
Fax: + 33 (0) 1 43 19 71 40

10 – LASERS

The use of lasers in the exhibition halls shall be permitted subject to compliance with the following provisions:

- in no case shall the public be subjected to the direct or reflected laser beam,
- the device and its ancillary equipment must be solidly attached to stable elements,
- the device's surroundings and the area covered by the beam must not contain elements reflecting the relevant wavelengths,
- the housing containing the laser and its optical deviation system must be class I or II (in accordance with standard NF C 20-030),
- Exhibitors must ensure, during testing outside the presence of the public, the absence of reaction from materials used for fitting-out and decorating the stand, and the fire protection equipment to the heat energy produced by the light beams.

A declaration for the all laser installations must be sent to the administrative authority (Prefecture, Safety Board) at least one month before the start of the event.

Contact the Safety Supervisor for information regarding the required administrative procedures regarding this request. Such declaration, on plain paper (to be attached to the declaration for the machine or device in operation included in the appendix), must be accompanied by the device's descriptive leaflet, and a drawing of the device's installation on the stand and a document drawn up and signed by the installer certifying compliance with the present provisions. No device of this type may be started if the declaration request was not submitted on time.

11 - EMERGENCY RESOURCES

Emergency resources must remain constantly visible.

Access to various emergency resources (fire hydrant and hydrant stems, first aid hose systems, telephones, extinguishers, smoke release hatches, etc.) must remain continuously unblocked.

12 - OPERATING INSTRUCTIONS

It is prohibited to create, on the exhibition surfaces, in the stand, and in clearance areas, piles of crates, wood, straw, cardboard, etc.

Periodic (daily) cleaning must remove dust and waste of all types from the premises. All waste and debris from cleaning and sweeping must be removed each day, before the opening to the public and be removed from the establishment.

On stands equipped with a first aid hose system, clearance of one metre next to the device must be left free of any equipment up to the public traffic alleyway.

The presence of panels or cloth masking the device is absolutely prohibited.

Safety & Fire Regulations (cont.)

SUMMARY OF FRENCH AND EUROPEAN EQUIVALENCES

- **M0** or **A** European Standards = Non combustible
- **M1** or **B** European Standards = Non flammable
- **M2** or **C** European Standards = Flammable with difficulty
- **M3** or **D** European Standards = Moderately flammable
- **M4** or **E** European Standards = Easily flammable

AUTHORIZED	MATERIALS	DOCUMENT TO BE SUBMITTED
Wood (or wood composite) > 18 mm not laminate	Wood (not laminate) agglomerated plywood lath	None (M3 assimilated materials)
Wood < 18 mm and > 5 mm Wood > 18 mm, laminate	M3 original or D European Standards	Report M3 (or Labels on materials)
Plywood - Agglomerate < 5 mm wood based composite	M1 or fireproofed on both sides with paint, varnish, salts by an approved applicator B European standards	Reports M1 or fireproofing certificate with name of the product, descriptive leaflet, application date
Carpets on the ground	Natural: M4 or E European Standards Synthetics: M3 or D European standards	Reports
Fabrics and surfacing wall textiles	M1 or fireproofed or B European standards	Reports or fireproofing certificate with name of the product, descriptive leaflet, application date
Plastic materials (plaques, letters)	M1 or B European Standards	Reports M1
Paint	Permitted on M0 , M1 supports or wood (nitrocellulose paint prohibited)	Reports regarding supports
Free-hanging decoration (paper, cardboard)	M1 or fireproofed or B European standards	Reports or fireproofing certificate with name of the product, descriptive leaflet, application date
Floral decorations made of synthetic materials	M1 originally (fireproofing prohibited) or B European standards	Reports M1
Bonded or clipped decoration (paper)	No substantiation required if bonded over the entire surface or clipped every 5 cm. Split Installation	
Furniture	Large furniture: M3 or D Light structures: M3 or D Padding: M4 or E Envelope: M1 or B	Reports or fireproofing certificate (so substantiation required if rented furniture)
Glazing	Reinforced, tempered, ply	Reports, certificates or substantiation such as an invoice
Other Materials	Request approval	Written response by the Safety Supervisor

N.B.: Reports only from approved French laboratories under current regulations as of November 1998 or, by equivalence, officially recognized by any report corresponding to European Standards applicable within Union Member States.

Disabled access

PREAMBULE

The order of 1st August 2006 lays out the conditions for application of articles R 111-19 to R 111-9-3 and R 111-19-6 of the Building and Habitation Code concerning the access of handicapped people in establishments for public use and installations open to the public during their construction or creation.

Generally the pavilions, exhibition halls, and installations in exhibition centres meet the requirements of this order: accessibility, toilets, car parking, etc...

Furthermore, regarding installations open to the public during their creation, it is necessary to allow handicapped people access to stands, conference or meeting rooms, grandstands, or catering areas.

In the shows organised by COMEXPOSIUM, the Security Manager is responsible for ordering any measures required and carrying out inspections at shows.

The general and specific measures applicable to installations created at trade shows and exhibitions are given hereafter:

ACCESS TO SINGLE-LEVEL STANDS

Each stand, area open to the public, fitted with a floor higher than 2 cm must be accessible to People of Reduced Mobility (PRM).

One or several ramps, of a minimum width of 90 cm, will facilitate this access. Slopes will respect the following percentages:

- 4% slope without limit to the length of the passageway
- 5% slope on a length of less than 10 m
- 8% slope on a length of less than 2 m
- 10% slope on a length of less than 0.5 m

Clearance of a radius of 1.5 m will be left free for manoeuvring at each end of the ramp.

PATHWAYS

- Width of 1.40 m minimum.

ACCESS TO STANDS ON UPPER FLOORS

1) When the numbers of general public hosted on the upper floor does not exceed 50 people, the services on the upper floor must be equivalent to the ground floor.

If this is not the case, and/or if the numbers of the public hosted on the upper floor exceeds 50 people, the upper floor will be accessible via a lift in compliance with the standard NF EN 81-70. This installation must be verified by an organisation approved by the Ministry of the Interior before its use.

2) Respect the provisions of article 7.1 of the aforementioned order, regarding staircases.

- Width of 1.20 m between hand rails.
- Two continuous hand rails, extended at the top and the bottom of the staircase, horizontally, returning on a partition or extended by the length of the tread of a step.
- A maximum step height of 16 cm and a minimum tread of 28 cm – step edges in contrasting colours
- 0.5 m width tactile foot strip at the top of the stairs.
- Respect the staircase design good practice: $60 \text{ cm} < 2 H + T < 64 \text{ cm}$ (H = step height, T = step tread).
- Hand rails and safety rails must respect the standards NF P 01-12 and NF P 01-013

FITTING OF ROOMS OR AREAS RECEIVING SEATED MEMBERS OF THE PUBLIC (CONFERENCES, STANDS, GRANDSTAND, ETC.)

Areas reserved for wheelchair users will be provided.

These areas must be located outside of alleyways and corridors and close to exits. The number will be calculated enabling two places for the first 50 seats and one place per additional 50 seats.

WELCOME AND INFORMATION DESKS

Welcome and information desks must be accessible to people using a wheelchair.

- Height 80 cm, a gap of 30 cm depth on a height of 70 cm, enabling space for knees.

Exhibitor Safety Instructions

IMPORTANT PLEASE NOTE

Legislation regarding the Prevention of accidents at work imposes health and safety protection coordination for any work site placing at least two companies or self-employed workers in the presence of one another.

The Exhibitor Instructions communicated to you defines all the measures set in place to prevent risks arising from the interference of the activities of the various people working on this event. This document was drawn up at the request of the show organizer by the coordinator Mr Patrick POUGNAND in accordance with the provisions defined by the texts in force and in particular the following law:

**Law of 31.12.1993 nr 93-1418 and the decree of 26.12.1994 nr 94-1159
Modified and complemented by the decree nr 2003-68 of 24.01.2003**

**You are therefore asked to study it and apply the regulatory measures defined in this document.
This General Coordination Plan cannot replace the provisions of the Code of Work.
It does not in any way reduce the responsibilities and duties of the companies working on the site.**

For SIAL 2014, this coordination mission is carried out by the COMEXPOSIUM Company via a delegated coordinator assisted by a team of experts who make up the safety group of SIAL 2014.

This document is a General Health and Safety Protection Plan Intended for the exhibitor, his suppliers and sub-contractors Founded on general prevention principles, namely:

- **To avoid risks**
- **To evaluate risks** which cannot be avoided
- **To combat risks** at source
- **To take account** of technical developments
- **To replace what is dangerous by what is not** or by what is less dangerous.
- **To plan prevention** measures by coherent integration of techniques, work organization and working conditions.
- **To take collective protection measures** giving them priority over individual protection measures

The exhibitor has a duty and legal obligation to:

1°) Validate the Safety Instructions Notice on the website of the show.

2°) Pass on the information about these instructions to all service providers appointed by himself who work during the assembly and dismantling periods on his stand.

IF YOUR STAND IS:

Installed by several independent companies.

Installed by a decorator/stand designer **using at least two** sub-contractors.

Includes a mezzanine floor.

If YES to at least one of these

**You must appoint an HEALTH AND SAFETY COORDINATOR
for the assembly and dismantling periods and communicate his contact details together
with his GHSPCP (General Health and Safety Protection Coordination Plan)
to the D.Ö.T Company before: 10 September 2014**

Your decorator/stand builder or yourself are not allowed to carry out this mission. Only a Health and Safety Coordinator having an official certificate of competence is allowed to carry out this mission

DÖT / SIAL 2014
81 rue de Paris – 92100 BOULOGNE
Fax: +33 (0)1 46 05 76 48
E-mail: sps@d-o-t.fr

Exhibitor Safety Instructions (cont.)

OBLIGATORY

During the assembly and dismantling periods, access to the exhibition halls will be authorised only to people wearing an Assembly/Dismantling badge

Obligation of protection reminder Cf : Chapter VIII-2 of this document

You are reminded that wearing safety shoes (reinforced toe caps + anti-perforation soles) is obligatory for anyone who enters the show site during these periods.
For all people working from elevated platforms and any task presenting a risk, wearing a hard hat is compulsory.

To be accepted into the halls, electrical tools, fixed or portable, must be equipped with a vacuum or dust collection system.

Art. R 4412-70 of code of work

EVENT ASSEMBLY AND DISMANTLING DATES

BARE STANDS EXHIBITORS

Halls	Building	Dismantling
1, 2, 3, 4, 5A, 5b, 6, 7	From 14 to 16 October 2014 from 7.30am to 7.30pm From 17 to 18 October 2014 from 7.30am to 10pm	The 23 October 2014 from 5pm to midnight From 24 to 25 October 2014 from 7.30am to 7.30pm The 26 October 2014 from 7.30am to 2pm
8	The 15 October 2014 from 8am to 7.30pm The 16 October 2014 from 7.30am to 7.30pm From 17 to 18 October 2014 from 7.30am to 10pm	The 23 October 2014 from 5pm to midnight The 24 October 2014 from 7.30am to 7.30pm The 25 October 2014 from 7.30am to 2pm

ESSENTIEL, ESSENTIEL+, ESSENTIEL+ SECTORIEL (VIN, BIO, EPICERIE FINE, INGREDIENTS), PREMIUM, PREMIUM+, PRESTIGE, OPTIMUM STANDS EXHIBITORS

Halls	Building	Dismantling
1, 2, 3, 4, 5A, 5b, 6, 7	From 14 to 16 October 2014 from 7.30am to 7.30pm From 17 to 18 October 2014 from 7.30am to 10pm	The 23 October 2014 from 5pm to midnight The 24 October 2014 from 7.30am to 7.30pm
8	From 17 to 18 October 2014 from 7.30am to 10pm	The 23 October 2014 from 5pm to midnight The 24 October 2014 from 7.30am to 2pm

On the last assembly day, no motorised vehicle will be allowed into the halls (Unless special dispensation has been granted by the organizer).

In the dismantling period, on 23 October 2014, motorised vehicles may only work after 7.00pm in the halls.

CONTENTS

I. GENERAL INFORMATION ABOUT THE OPERATION	VII. ACCESS CONTROL
II. ADMINISTRATIVE INFORMATION	VIII. PROTECTIONS
III. GENERAL ORGANIZATION OF THE SHOW	IX. GENERAL RULES OF CONSTRUCTION
IV. HANDLING CONDITIONS	X. FIRE SAFETY
V. CLEANING	XI. ORGANIZATION OF EMERGENCIES
VI. INSTALLATIONS AVAILABLE DURING ASSEMBLY AND DISMANTLING	XII. THE INDIVIDUAL HEALTH AND SAFETY PROTECTION PLAN

I. GENERAL INFORMATION ABOUT THE OPERATION

I. 1. DEFINITION

The Exhibitors' Safety Instruction is a document written and devised by the coordinator defining all appropriate measures to prevent hazards arising from the interference of the activities of different companies during assembly and dismantling of SIAL 2014

It must be communicated to all exhibitors who must transmit it to their stand designer /suppliers when they have named them. It enables them to inform Suppliers and Sub-contractors about the special measures to apply to ensure safety at work.

I. 2. COMPOSITION

The Safety Instructions including a certificate.

The safety regulations of the Venue and the Fire Safety instructions are available from the organizer.

I.3. DEFINITION OF THE COMPANY

Any firm that provides services to the exhibitor, and is charged with creating the infrastructures of the stand is considered as a company. The exhibitor is responsible for his own suppliers and sub-contractors.

The company director remains responsible for the safety of his employees and is required to implement the means necessary to avoid and control risks.

The courts severely sanction any damage to the health or safety of employees and the civil and / or penal liability of the company director can be invoked.

The companies declare that they have taken note of the texts quoted in this document, as well as the general conditions of the show organization deposited with the organizer.

In addition, it is supposed that companies have:

- a). Taken note of plans and documents useful in carrying out the work, and of event technical files, and that they have taken due note of the sites, places and installation areas of major structures and of all general or local elements relating to the execution of the work,
- b). Perfectly understood all the conditions for carrying out the work and have been made fully aware of their importance and their particular features.
- c). Made a detailed visit of the site and taken note of all the physical conditions and all constraints pertaining to the places of work, accesses and surroundings, to the ready execution of the work, and to the on-going organization and operation of the worksite.

Exhibitor Safety Instructions (cont.)

II. ADMINISTRATIVE INFORMATION

II.1. THE PARTICIPANTS

II. 1. 1 General Organization

The SIAL Company acts as the general exhibition organizer of SIAL 2014.

ORGANIZER / EMPLOYER	GENERAL SHOW DIRECTOR
COMEXPOSIUM 70 avenue du Général de Gaulle 92058 PARIS LA DEFENSE Cedex Tel : +33 (0)1 76 77 11 11 Fax : +33 (0)1 53 30 95 15	Mr Nicolas TRENTESAUX Email : nicolas.trentesaux@comexposium.com
LOGISTICAL, SAFETY & SECURITY DIRECTOR	LOGISTICAL, SAFETY & SECURITY MANAGER
Mr Jérôme HUNAUT Tel : +33 (0)1 76 77 13 65 Email : jerome.hunault@comexposium.com	Mr Gilles CRESPON Tel : +33 (0)1 76 77 12 28 Email : gilles.crespon@comexposium.com
Contact receiving exhibitors' demands	
Mrs Florence BERNARD Tel : +33 (0)1 76 77 13 33 Email : exhibit@sialparis.com	
INSURANCE AGENCY – Civil resp / Dam.to property	TOWN HALL
SIACI 18 rue de Courcelles 75384 PARIS Cedex 08 Monsieur Michel GARRIDO Tel : + 33 (0)1 44 20 96 29 E-mail: michel.garrido@s2hgroup.com	MAIRIE DE VILLEPINTE Place de l'Hôtel de Ville 93240 VILLEPINTE Tel : +33 (0)1 41 52 53 00

II.1.2. HSP Coordination / Fire Safety

HSP COORDINATOR	FIRE SAFETY REPRESENTATIVE
D.Ö.T 81 rue de PARIS - 92100 BOULOGNE Tel : + 33 (0)1 46 05 17 85 Fax: +33 (0)1 46 05 76 48 Email: sps@d-o-t.fr	Philippe WATTEAU 41 rue Lazare Carnot 77340 PONTAULT COMBAULT Tel :+33 (0)6 85 94 49 57 Fax: +33 (0)1 70 10 40 11 E-mail: philippewatteau@numericable.fr

The fire safety representative will be present on site from 10 to 23 October 2014

The date of the safety committee tour of inspection hasn't been defined

FIRE PROOFING	
Groupement NON FEU 37-39, rue de Neuilly BP 249 - 92113 CLICHY Tel : + 33 (0)1 47 56 31 48	Groupement Technique Français de l'ignifugation 10 rue du Débarcadère 75017 PARIS Tel: + 33 (0)1 40 55 13 13
EXPERT IN THE SOUNDNESS OF MAJOR STRUCTURE	
SOCOTEC Centre d'affaires PARIS-NORD Le Continentale - BP 306 93153 LE BLANC MESNIL Cedex Tel: +33 (0)1 48 65 42 37 Fax: +33 (0)1 45 91 19 63	

Exhibitor Safety Instructions (cont.)

II.2. DEFINITION OF WORK AREAS

VENUE	HALLS
VIPARIS PARIS NORD VILLEPINTE BP 68004 95970 ROISSY CHARLES DE GAULLE Cedex Accueil : Tel : +33 (0)1 40 68 22 22 Service Exposants: Tel : +33 (0)1 40 68 16 16	1, 2, 3, 4, 5A, 5b, 6, 7 & 8

II.3. THE OFFICIAL BODIES

INSPECTION OF WORK	CRAMIF
1 avenue Youri Gagarine 93000 BOBIGNY Tel: +33 (0)1 41 60 53 00	Service des risques professionnels, Antenne 93 17/19 avenue de Flandre 75954 PARIS Cedex 19 Tel : +33 (0)1 44 65 54 50
O.P.P.B.T.P.	Glossary
1 rue Heyrault 92660 BOULOGNE Cedex Tel : +33 (0)1 40 31 64 00	CRAMIF : Caisse Régionale d'Assurance Maladie d'Ile de France OPPBTP : Organisme Professionnel de Prévention du Bâtiment et des Travaux Publics

II.4. EMERGENCY SERVICES ON THE SHOW SITE:

EMERGENCY POST	GENERAL SURVEILLANCE POST
Hall 1 Access Gallery Medical Office Hall 6 Tel: +33 (0)1 48 63 31 15	Tel : + 33 (0)1 48 63 30 49
	FIRE SAFETY
	Tel : + 33 (0)1 48 63 30 49

OFF SITE:

FIRE SERVICE	POLICE STATION
1 chemin des Vaches 93290 TREMBLAY EN FRANCE Tel: 18 ou 112 (portables) ou + 33 (0)1 48 60 69 48	1/3 rue Jean Fourgeaud 93420 VILLEPINTE Tel: 17 ou + 33 (0)1 49 63 46 10
SAMU	NEAREST HOSPITAL
125 rue de Stalingrad 93000 BOBIGNY Tel: 15 ou + 33 (0)1 48 96 44 44	Hôpital Intercommunal Robert Ballanger Boulevard Robert Ballanger 93602 AULNAY SOUS BOIS Tel: + 33 (0)1 49 39 71 23 / 22

III. GENERAL EVENT ORGANIZATION

III.1. GENERAL PRESENTATION OF THE SHOW

Cf. Exhibitor's guide

III.2. SCHEDULE OF USE OF HALLS

Public opening

DATES & TIME
From 19 to 22 October 2014 from 9.30am to 6pm The 23 October 2014 from 9.30am to 5pm

III. 3. VARIOUS SERVICE PROVISIONS

Cf. Exhibitor's technical guide

III. 4. SITE CONSTRAINTS

III. 4. 1 Traffic movements inside the park

Exhibitor Safety Instructions (cont.)

The temporary occupation of this site implies compliance with the standards and conditions (Times of access, parking, speed etc...) defined by the regulations in force in this enclosure and its surroundings. These regulatory texts, as well as the site specifications, can be consulted by contacting the Organizer.

Management of parking (and its duration), traffic movements and access to delivery vehicles displaying authorisation will be set up around the halls and in the park. (See Exhibitor Guide).

Private vehicles must be parked in the car parks. They must not approach the surroundings of the halls. Any vehicle even parked, must be able to be identified

III.4.2. Traffic movements inside the halls.

No delivery or private vehicles will be allowed in the halls, during the assembly and dismantling periods, without access authorisation from the organizer.

Means of transporting people (motorised or not) such as: scooter, bicycle, roller blades, electric vehicles, etc... are prohibited in the halls.

Plans showing traffic movement areas, position and contact details of emergency services, the location of open toilet facilities, access schedules for machines and the storage areas will be posted at the entries.

**The free movement (of men and lifting equipment) around the stands must be possible at all times during assembly and dismantling.
There must be no storage or parking on the traffic movement areas defined on the plan of the halls.**

RESPECT: INSIDE

- The paths marked out for fire services and traffic movement areas
- The storage areas
- The environment by using non-polluting machines

RESPECT: OUTSIDE

- Access routes for fire services
- Parking areas
- Unloading areas
- Access gates

IV. HANDLING CONDITIONS

IV.1. GENERAL REMARKS

The movement of machines presents risks and must be reduced to a minimum by strict management and distribution of the equipment.

Companies listed by the exhibitor are asked to set up means of identifying the machines and the men (stickers, identification jackets, etc...)

Lifting and handling equipment must satisfy the requirements of current regulations.

They must be kept in good working order and have satisfied regular inspections in conformity with the Article R 4535-7 of Code of work.

Machines must hold the following documents.

- Valid insurance certificate
- Valid certificate of conformity (checking report of lifting devices).

Pallet trucks must not be overloaded. It is important to take account of the centre of gravity of the load and the state of the ground to ensure that the load does not overturn.

It is strictly forbidden to climb on machine not provided to transport passenger

Necessary organizational measures should be taken to limit recourse to manual handling to the minimum. (Article R 4541-3 of Code of Work)

However, when it cannot be avoided, the employer must take appropriate measures or put at the disposal of the workers, suitable measures, to limit physical effort and to reduce risks during handling (Mechanical assistance, grasping means)

The weight of the loads must be reduced and the working post must be adjusted to do the handlings in the best conditions. (Working space, reduction of the distance that the loads need moving...)

The staff must be trained in the risks of handlings.

The load must not split when it is moved.

Exhibitor Safety Instructions (cont.)

For the handling of glass panels, it is recommended to use suction cups. In the same way, for handling plywood sheets, the use of handling clips or panel carriers is recommended.

The containers of bulk loads intended to be hung on working equipment used for lifting must be capable of resisting the efforts undergone during the loading, transport, handling and storage of the load and be equipped to prevent the untimely collapse of all or part of the load during the same operations.

The use of straps to fix the loose loads on the forks of the lifting trucks is obligatory.

IV.2. USE OF MACHINES WITH AN ENGINE

The drivers must be at least 18 years of age and hold driving permits issued by the employer as well as the CACES (safe driving aptitude certificate) and the Special Medical Fitness Certificate.

These documents must be available for inspection on the site. The users of these machines must comply with the manufacturer's instructions. No carrying a passenger, no lifting a person if the machine is not intended for the purpose, USE OF NON-POLLUTING MACHINES adapted to the tasks, places, loads and configuration of the ground.

The speed limit must be respected for any movement outside the halls. It must be reduced and appropriate inside the halls

IV.3. LIFTING REGULATIONS

For any use of a crane, a special request must be made to the organizer.

This request must specify where the crane will be operating and the technical constraints of use and assembly. These constraints must appear in the company I.H.S.P.P.

The certificate of conformity of this equipment must be available for inspection.

It is essential that the maintenance and operation of all lifting gear are exclusively carried out by the company, which provides the equipment. This equipment is the sole responsibility of this company.

Whatever the means of lifting used, **the users must take care not to work over any other workers and to take all necessary safety provisions.**

Lifting loads over the traffic aisles is banned, except with the presence of a guide who must warn the people of this operation.

The maximum load indications of each strap must be respected.

The lifting works must be done in accordance with the articles R 4534-95 à 102 of the French Code of Work

REMINDER : IT IS FORBIDDEN

- To drive a truck without a driving licence.
- To allow your truck to be driven by an unauthorised person.
- To lift a load greater than the machine's capacity.
- To increase the value of the truck's counterweight
- To lift a poorly balanced load.
- To lift a load with only one arm of the fork.
- To move around with a high load.
- To brake sharply.
- To take corners at high speed.
- Not to observe traffic signs.
- To use traffic lanes other than those established.
- To carry people on trucks not specially designed for the purpose.
- To leave the engine running in the absence of the driver.
- To lift people with trucks not specially designed for the purpose.
- To abandon a truck in the movement aisles or on a slope.
- To leave the ignition key in the vehicle when the driver is absent.
- To park or go under a fork in the high position, even unloaded.
- To smoke near a charging battery or while thermal trucks are being filled.
- To place metal parts on accumulator batteries

IV.4. STORAGE

It is imperative for materials to be stored on the aisles (or parts of aisles) reserved for this purpose, in the enclosure of the worksite or the storage areas when they are provided.

For this purpose, traffic movement plans will be posted at the accesses to the halls. The schedules and restrictions of use will be specified on these plans.

All workers are asked to respect these plans scrupulously.

At the end of assembly, racks, pallets, etc... must not be stored inside the Show and in the areas behind the claddings (unless authorised to do so by the organizer).

Machines must not be stored, during the assembly–dismantling period, in the traffic movement aisles, but in a storage area determined with the organizer's technical managers.

Exhibitor Safety Instructions (cont.)

The exhibiting companies (and their subcontractors) must schedule the arrival of their equipment and materials, their distribution, as well as the departure of empty packaging so that they do not interfere at any time with the movement of machines and men in the aisles.

For the period when open to the public, no machine will be allowed in the enclosure of the halls.

V CLEANING

Exhibiting companies are responsible for cleaning their site and removing their rubble and waste of all kinds.

The worksite must be kept clean at all times to prevent hazards that could be caused by rubbish blocking the aisles around the stand.

They must plan the reservation and removal of skips and organise how they are filled. It is the responsibility of each worker either to cover the skips, or to weigh down the rubble to prevent it from flying around.

You are reminded that no worker must climb into a skip or truck.

VI. INSTALLATIONS AVAILABLE DURING THE ASSEMBLY AND DISMANTLING PERIODS

VI.1. INSTALLATIONS IN COMMON

To ease the general organization of assembly and dismantling, and improve working conditions, the Safety Coordinator demand to the Organizer to ask the Venue to open additional communal toilet facilities in the exhibition halls **from the first day of assembly to the end of dismantling**. A maintenance service will see to the cleaning of these facilities

The toilet facilities that are open will be indicated on the plans posted up at the halls entrances.

VI.2. CLOAKROOMS

The company is required to place cloakroom facilities (if necessary) at their staff's disposal, in application of current legal texts, available for consultation from the organizer.

There will be no canteen for meals.

VI.3. TELEPHONE ON SITE

Each company places at its staff's disposal a telephone accessible when the site is open for work.

VI.4. ACCOMMODATION

The Company is responsible for providing off-site accommodation for its staff.

VII. ACCESS CONTROL

VII.1. PROTECTION OF WORKERS

VII.1.1. Medical fitness

All personnel called upon to work on the site must be recognised as being medically FIT, and have undergone the obligatory medical examinations and vaccinations associated with the exercise of their profession, as well as those required by Medicine of Work. These certificates must be available on the site.

VII.1.2. Safety training

In conformity with current regulations, and at its own responsibility, the company must ensure that every worker arriving on the site has attended safety-training sessions. (Presentation of special risks, conditions of traffic movements outside and inside the site, safety conditions applicable when carrying out work, special safety instructions, explanation of the operating method, follow-up of preventive measures that have been defined for each task in the Individual Safety and Health Protection Plan).

VII.2. REGISTERS

VII.2.1. Legal Registers

The enterprise must hold obligatory legal documents at the site, as they may be asked for by administrative inspection services.

VII.2.2. Joint site visits

When they arrive on the assembly and dismantling site, companies who have never worked on the site before must make a joint inspection visit with the Safety Coordinator of their stand. A site visit file will be established by the Coordinator and signed by each company manager.

The safety and protection measures are defined with the site managers and the stand Safety Coordinator in reference with the G.H.S.P.C.P established by the Coordinator, taking account of the event G.H.S.P.C.P according to the state of the site at the time of the visit and the way the visit is carried out.

VII.3. ACCESS

Access to the show site is only possible for persons and vehicles carrying authorisation or a badge given by the organizer.

Exhibitor Safety Instructions (cont.)

Badges will be distributed to each worker in the event.

Notices prohibiting access to the public stating the essential safety regulations to be observed on the site will be posted up at the halls entrances. These accesses will be guarded. Visits to the worksite by persons other than the authorised workers (children, friends, family, pets...) are strictly forbidden.

VIII. PROTECTION

The workers are reminded that they must give **priority to COLLECTIVE protections** over INDIVIDUAL protections, anytime that it is technically possible.

VIII.1. COLLECTIVE PROTECTION

Definition: Standardised means of protection set up by a company (barriers, nets, floor, cladding, guard rails...); designed to ensure the collective safety of staff working at a height or on an upper floor during assembly and dismantling.

This collective protection must be rigid composed of a high and low hand rail and a baseboard, safely attached and must be installed from the outside with appropriate means, before any work is purchased on a storey or at height during assembly or dismantling. It must be removed only after the installation of the definitive protection or partition. The stairs must be assembled as a priority and made safe by guardrails as soon as they are set up.

**The stairs cavities must be protected (Closed or with a guardrail).
Material deliveries access must be secured.**

It is reminded that the structure of the mezzanine, or high decorative parts must be designed to take collective protection

For the dismantling all these protection must be reinstalled.

Each company in their respective Individual Health and Safety Protection Plan must describe collective protections.

The company must see to the maintenance of collective protections and will be held responsible if work is carried out in areas not prepared and not protected. It must intervene immediately at any direct request from the stand Coordinator to restore or supplement these protections.

Article R 4323-65 – The collective protection devices must be designed and installed in order to avoid a gap at work station access points namely when a ladder or staircase is used. However when such a gap is unavoidable measures must be taken to ensure equivalent safety.

If a company fails to establish collective protection, the absence of which constitutes a risk for other trades and its own staff, the exhibiting company will have these collective protective measures set up by a company of its choice, at the expense of the defaulting company.

Any ensuing work stoppage will also be charged to the defaulting company.

VIII.2. INDIVIDUAL PROTECTIONS

When collective protection system cannot be implemented, the workers protection must be ensured by appropriate "stop falling" system that cannot permit a free fall as more as one meter. When this kind of equipment is used, the worker must never leave alone.

Companies that have to intervene during the assembly and dismantling periods must, among other things, provide their staff with the following individual protection equipment (IP):

- Work clothes,
- Gloves adapted to the work,
- Safety hard hats compliant with standards,
- Safety shoes (reinforced toes + anti-perforation soles),
- Safety harness that conforms to standards when the collective protection provisions cannot be implemented. (Art R 4223-61 of the Work Code).
- Welding mask and safety goggles during welding, unloading or grinding work.

Respect for these provisions, and the upkeep and good condition of this equipment is the responsibility of each company.

**Wearing safety shoes (safety toe-caps + anti-perforation soles) is compulsory for any person entering the show site during the assembly and dismantling periods.
For all people working from elevated platforms and any task presenting a risk, wearing a hard hat is compulsory**

IX. GENERAL RULES OF CONSTRUCTION

IX.1. DECORATIONS

The decorations must, as much as possible, arrive on the site ready to be assembled so as to reduce building operations to the minimum and the risks which result from this. They must be designed for safe, clean dismantling.

It is strictly forbidden to « blow out » panels and partitions during dismantling

IX.2. WORKING AT HEIGHTS

Decree nr 2004-924 of 01.09.2004 concerning the use of work equipment made available for temporary work at a height and integrating new provisions in the labour code (Articles R 4323-58 to R 4323-90).

It is obligatory for companies installing marquees, tents or structures, during the assembly, maintenance and dismantling periods, to set up collective protection measures appropriate for any work on roofs by their staff. The methods considered for carrying out this work must appear in the company I.H.S.P.P.

In any case the people working for the building and dismantling must have a certificate to work at height and a valid authorization from his employer.

Ladders, stepladders and footstep platforms must not be used as work positions.
(Article R 4323-63 of the work code)

However these facilities may be used when it is impossible to use equipment providing a collective protection to the workers or when the risk has been evaluated as low and the work is for a short and non-repetitive length of time (article R 4323-63 of the work code)

The companies may work at heights with scaffoldings or mobile platforms

Approved personnel must assemble scaffolding, respecting the directives or instructions of the manufacturer; the platforms must be correctly positioned, **guardrails and stability props must be in place.**

Article R 4323-77 – scaffolding must be equipped on the exterior sides with collective protection devices as outlined in paragraph 2 of the article R 4323-59.

The scaffolding must be level when it is used.
The wheels of mobile scaffolding must be locked in position when it is in use.

No worker must remain on mobile scaffolding while it is being moved.

For the assembly of scaffolding, steps, etc..., it is essential for companies to equip their personnel with hard hats and safety harness, in addition to safety shoes and gloves. They must make sure that the use of these I.P. by their personnel is effective.

Legal restrictions concerning work at heights must be respected.

IX.3. MEASURES TAKEN CONCERNING CO-ACTIVITY

Companies must provide a detailed assembly and dismantling schedule in their I.H.S.P.P

Any work which might create a situation placing workers over each other must be resolved by carrying out the work at different times, or with special protection arrangements.

Within the framework of the timetable of assembly and dismantling work, companies acting on the same site must take all appropriate individual protection measures to prevent hazards caused by superimposed work, particularly during the installation and dismantling of gantries, signposting, light adjustments of the altimetric readings, and assembly/dismantling of large equipment.

The exhibitor or his project manager must set up a work schedule taking into account a chronological order of assembly, to avoid tasks at different levels in the same site and to carry out these tasks using suitable means.

These means can be common to several workers or companies.

This chronological order will be in the same way adapted to dismantling.

The external working areas must be marked out or cordoned off with barriers so that they are inaccessible to people not involved with the assembly. The fences or barriers must in all cases be stabilised so as not to overturn if there are gusts of wind or if knocked into by a vehicle.

IX.4. SITE CONNECTIONS / LIGHTING

IX.4.1. Regulations

Electrical installations on the worksite must be carried out according to regulations in force.

The personnel working on the electrical installations must have received training and must hold an approval certificate under publication UTE C 18510.

Moreover, companies, which use the installations, are required to point out immediately any defect or deterioration they observe to the managers of the Exhibition site.

Exhibitor Safety Instructions (cont.)

The technical traps of the hall must be correctly closed or protected in case of temporary opening to avoid any risk of falling of people.

An approved body must inspect the worksite electrical installation before being brought into service. This inspection report must be available for consultation and kept on site throughout the assembly and dismantling periods.

To avoid risks of electrocution, deterioration of electricity cables, and the multiplication of connections on a same line: **Unauthorised connections on the existing power points in the halls will not be tolerated.**

All the worksite cables and extension leads must be in good condition and compliant with current standards.

Worksite electricity cabinets are available from the Park.

IX.4.2. Lighting

The general lighting in the work areas must be compliant with lighting regulations determined by decree nr 83.721 of 2 August 1983 and repeated in the work code in articles R 4223-1 to 12

Light intensity in working areas must be at least 120 Lux, and 60 Lux in traffic movement aisles.

The assembly and dismantling of decors may obscure the light in the halls (roofing, canopy, stretched ceiling, mezzanine floor...), so provisional lighting must be provided.

IX.5. PREVENTION OF RISKS OF PROFESSIONAL DISEASES

IX.5.1. Hazardous materials

It is imperative for any company that needs to use hazardous products to send the safety data sheets to the Safety Coordinator and to the Fire Safety Control Agency, and **put in place the protection measures specified on the sheet.**

Companies are informed that any glue, resins, paint and products used must be free from solvent, ether, glycol, and be odourless and antiallergic.

IX.5.2. Noise disturbance

The use of noisy machines or equipment must adhere strictly to current regulations.

All necessary methods and provisions must be used (hood, screen, silencer etc...) so as not to exceed the regulatory limits as regards acoustic levels.

IX.6. RULES FOR USE OF ELECTRICAL TOOLS, FIXED OR PORTABLE.

To avoid dust, fumes emission or noxious emanations when fixed or portable electrical tools are used (Saws, sanders, blowtorches, welding torches, etc...), efficient protection means must be provided (Central vacuum, masks, glasses...).

Only water disc cutters will be allowed for cutting tiles, stones...

To be accepted into the halls, electrical tools, fixed or portable, must be equipped with a vacuum or dust collection system.

Art. R 4412-70 of code of work

These appliances must be compliant with the standards (CE), be in good operating condition and equipped with their protective shields. **They must in no circumstances be placed in the movement aisles**, and the electricity supply must be disconnected when they are not in use.

IX.6.1. Fire permit

An extinguisher appropriate to the risks must be placed by the user company near hot point work (welding stations, etc...)

For any grinding or welding operation, **a fire permit** must be applied for from the venue department in charge.

Gas bottles under pressure must be protected from knocks, falls and heat, and no unauthorised person must be able to have access to them.

It is forbidden to keep or store gas bottles, full or empty, in the halls.

X. FIRE SAFETY

The fire safety regulations are deposited with the organizer and available in the Exhibitor Guide.

Exhibitor Safety Instructions (cont.)

The Official Safety Committee is very strict as regards structural construction (construction and decoration materials, solidity and stability of structures, upper floors, emergency provisions, electrical fittings, etc...).

The decisions taken by the committee during its tour of inspection are enforceable immediately.

At the time of this Committee's tour of inspection, the stand installation must be complete. The exhibitor (or his representative) must be present on the stand and be in a position to supply fire reaction reports drawn up by an approved French laboratory in respect of all materials used, together with the reports of inspections of electrical installations, soundness of structures, etc...

Failure to respect these regulations may involve the removal of materials, or it may be forbidden for the stand to be opened to visitors.

XI. ORGANIZATION OF EMERGENCIES

XI.1. COMPANY EMERGENCY MEASURES

The company must have a first aid kit available on the site. The contact details of the show's emergency first aid post are indicated on the halls plans.

The first-aid worker present within each company on the site will provide first aid in the event of an accident.

They must wear an identification pictogram on an armband or on their helmets and their names must be entered in the I.H.S.P.P.

In case of accident precise:

- The hall
- The stand name
- The lane and the stand number
- Number of people involved and injuries kinds

THE EMERGENCY PHONE NUMBERS ARE DISPLAYED AT THE TECHNICAL OFFICE

XI.2. COLLECTIVE ORGANIZATION OF THE SHOW

Reminder of the emergency phone numbers

EMERGENCY POST:
Galerie d'accueil Hall 1 - Local Médical Hall 6
Tel : +33 (0)1 48 63 31 15

GENERAL SURVEILLANCE POST : +33 (0)1 48 63 30 49

FIRE SAFETY : +33 (0)1 48 63 30 49

XII. THE INDIVIDUAL HEALTH AND SAFETY PROTECTION PLAN

All the exhibitor's stand providers must draw this document

At least 30 days before any assembly for main contracts
At least 8 days for work of short time and/or finishing work.

All the companies working for the exhibitor must give this form to stand employer and to the safety coordinator if the case arises before any work on building site.

It gives a detailed analysis of the construction and execution processes as well as the chosen operational methods when they have a particular effect on the health and safety of the people working on the site.

XII.1. THE EXHIBITOR

The exhibiting company must give a copy of the Safety Instructions drawn up by the show Safety Coordinator to their service providers or to the safety coordinator appointed for his stand. This document deals with the selected general organization measures which are of a nature to have an influence on the health and safety of the workers.

XII.2. COMMUNICATION OF THE DOCUMENT

The stand Safety Coordinator is required to communicate to every company working on the site (at their request) the names and addresses of the other contracting companies, together with their I.H.S.P.P.

XII.3. AVAILABILITY OF THE I.H.S.P.P.

A copy of the I.H.S.P.P. must be available at all times on site for consultation by the companies concerned.

SIAL 2014

The Global Food Marketplace

Forms



an event by
comeXPOSIUM
The place to be

Refund of French TVA (VAT)

Current regulations:

Since the entering into force of the VAT package on January 1st, 2011 concerning trade show services, the applicable VAT rules have been changed. Nevertheless the French Tax Authorities consider (instruction 3 A-2-11 of March 28th, 2011) that space rental during a trade show is a land related service and therefore taxable in France.

Thus, certain services, including services supplied by the organizer of the trade show, are still invoiced with French VAT: rental of non-equipped spaces, participation/admission fees, parking, technical services (electricity, stand cleaning...), catering, restaurant expenses...

Foreign companies, based in or outside the European Union and which are taxable persons, may under certain conditions obtain the refund of the VAT.

VAT is refunded on all kind of expenses except on the following: accommodation (hotel, apartment rental) for employees of your company and transport of persons (taxi, car rental, petrol, train, plane).

To receive further information about the refund claim and the refund procedure, exhibitors can contact directly our French Tax Representative, TEVEA INTERNATIONAL (see reply coupon below).

TEVEA International is specialized in handling TVA refund claims and will take care of the entire procedure until payment of your refunded amount. The procedure will be simple and easy for your company.

Reply Form

Please return to: **TEVEA INTERNATIONAL**

Claudia Prams

29-31, rue Saint-Augustin – 75002 PARIS – FRANCE

Tél. : +33 (0)1 42 24 96 96 – Fax : +33 (0)1 42 24 89 23 – email : mail@tevea.fr

www.tevea-international.com

N° Siret: 331 270 280 00067

We participate at the following exhibition:

SIAL 2014 – From 19th to 23rd October 2014 – Exhibition Park Paris Nord Villepinte

Please send us all information and documents concerning the TVA refund claim in following language:

FRENCH ENGLISH DEUTSCH ITALIAN SPANISH

Company:

Address:

Postal-code: Town: Country:

Tel: Fax: Email:

Contact name: Date and signature:



Form MANDATORY AFFIDAVIT WHEN USING A SERVICE PROVIDER IN FRANCE RESIDING OR ESTABLISHED ABROAD

Please return before **August 29, 2014** to:
DIRECCTE – 14^{ème} section
1, Avenue Youri Gagarine 93016 BOBIGNY CEDEX - FRANCE
Tél. : +33 (0)1 41 60 53 24 Fax : +33 (0)1 41 60 22 97
Courriel : dd-93.inspection-section14@direccte.gouv.fr

Exhibitor no.

Location reference

Company name:
Case manager:
Address:
Postcode: Town/City:
Country:
Tel: : Fax:
Mobile:
E-mail:

Stand no.: Pavilion:

IMPORTANT: SWORN AFFIDAVIT

I the undersigned
Acting as:
For:
Located at:.....
Solemnly declare that I:

- understand the mandatory formalities required for a service performed in France by a company established or domiciled abroad,
- shall comply and ensure compliance by my service provider with all the aforementioned formalities.

Mandatory Corporate Seal

Drawn up and signed in.....,
on

Authorized person's last name, first name, and signature, preceded by the wording "lu et approuvé" [read and approved].

FORM: SECONDMENT STATEMENT

Use of Foreign Labour by a Service Provider

Please return⁽¹⁾ before **August 29 2014**, to:

in French, by fax or electronic transmission

DIRECCTE – 14^{ème} section

1, Avenue Youri Gagarine 93016 BOBIGNY CEDEX - FRANCE

Tél. : +33 (0)1 41 60 53 24 Fax : +33 (0)1 41 60 22 97

Courriel : dd-93.inspection-section14@direccte.gouv.fr

EXHIBITOR

Company name: Address:
 Contact :
 Tel.: : Fax: Postcode: Town/City:
 E-mail: Country:

IMPORTANT: the Secondment Statement must be submitted regardless of the seconded foreign employee's nationality

1 - Service Provider (employer)

Name or Company Name			
Full foreign address			
Telephone		Fax or e-mail	
Legal Form			
Employer inscription or registration in the country of establishment	Register		
	References		
Corporate director's(s') identity			

2 - Service Provider's representative in France (identity of the representative for the duration of the service)

Last Name			
Address			
Telephone		Fax or e-mail	

3 – Service Provider's Principal

Name or Company Name			
Address			

4 – Service in France

Core activity performed			
Address(es) (work site, firm)			
Start Date		Expected Date	
Use of dangerous equipment or processes	NO	YES, please specify	
Workday start time ⁽²⁾			
Workday end time ⁽²⁾			
Number of rest days per week ⁽²⁾			

FORM: SECONDMENT STATEMENT

Use of Foreign Labour by a Service Provider (cont.)

5 - Seconded Employees⁽³⁾ (list may be continued on a separate sheet if necessary)

No.	Last Name	First Name	Date of Birth	Nationality
1				
2				
3				
4				
5				
6				
7				
8				
9				
10				

No.	Employment Contract Date in Country of Origin ⁽⁴⁾	Professional Qualification	Job held in France	Gross monthly salary in France (€) ⁽⁵⁾
1				
2				
3				
4				
5				
6				
7				
8				
9				
10				

Collective Accommodations / Address	
-------------------------------------	--

Mandatory Corporate Seal:

Date:

Filer Signature:

⁽¹⁾ An employer who has not filed a statement with the Labour Inspectorate may be subject to a fine provided for third class misdemeanours.

⁽²⁾ In France, at least one day of rest per week must be granted (a week being understood as from Monday at midnight until Sunday at 11:59 p.m.). The maximum working week is 48 hours per week and 10 hours per day. There is a break between the start and end of work each day and a break is mandatory after 6 hours of effective continuous work.

⁽³⁾ The employer must specify the identity of all employees to be seconded in France, whether they are European Union nationals or from a non-EU country

⁽⁴⁾ Seconded workers in France must be employed before secondment.

⁽⁵⁾ Please remember that the minimum hourly rate is €9.43 gross per hour as of 1 January 2014

WORK PERMIT FORM

For a secondment lasting less than three months for foreign employees

Form to be completed and returned before **August 29 2014**, to:

with the items and tables attached in French, by registered letter

DIRECCTE – 14^{ème} section

1, Avenue Youri Gagarine 93016 BOBIGNY CEDEX - FRANCE

Tél. : +33 (0)1 41 60 53 24 Fax : +33 (0)1 41 60 22 97

Courriel : dd-93.inspection-section14@direccte.gouv.fr

Exhibitor

Company name:

Contact:

Address 1:

Address 2:

Postcode: Town/City:

Country:

Tel.: : Fax:

Tel.: Professional (mobile preferably):

E-mail:

This procedure is not applicable to employees who are European Union or European Economic Area (EEA) nationals, or to foreign – non-EU citizen – employees who are legally employed by a firm established in the EU, as the latter are not subject to a work permit.

The exempt countries are as follows:

Germany, Austria, Belgium, Bulgaria, Cyprus, Denmark, Spain, Finland, France, Greece, Ireland, Italy, Luxemburg, Malta, The Netherlands, Portugal, United Kingdom, Sweden, Estonia, Hungary, Latvia, Lithuania, Poland, Slovakia, Slovenia, Romania, Czech Republic, Iceland, Liechtenstein, Norway, Switzerland, Andorra, Monaco, and San Marino.

EMPLOYER'S HANDWRITTEN REQUEST

Or, where appropriate, by a person established in France duly authorized to perform administrative procedures in his name and on his behalf presenting the reasons for the secondment and the type of jobs performed in France by the seconded employee(s).

ITEMS TO ATTACH, DRAFTED IN FRENCH

1. One copy of CERFA [French Administrative Form Registration and Revision Centre] form no.13647*01 "Request for a Work Permit for a Seconded Employee (excluding intra-group mobility)" duly completed (it may be downloaded from www.immigration.gouv.fr); do not attach appendices 1, 2, or 3 listed by the document.
2. A letter signed by the seconded employee, stating that he agrees to leave France when his job is complete.
3. A copy of the seconded employee's passport (identification and validity pages).
4. A secondment certificate in the employee's name or a sworn affidavit regarding an application for registration with the French Social Security (in the second case, Social Security registration shall be established through the Bas Rhin URSSAF [Social Security Contribution Collection Office] located at 16 rue Contades, 67307 Schiltigheim Cedex
Tel.: : +Fax: +33 (0)369323008
33 (0)1 70 96 13 00 e-mail: cnfe.strasbourg@urssaf.fr
Website: www.strasbourg.urssaf.fr
5. If a third party is authorized by the employer established abroad to submit the work permit request to the administration, the original of the employer's letter authorizing this person; the authorized person must be capable of providing the requested information and documents.

Mandatory Corporate Seal

Date:

Filer Signature:

WORK PERMIT FORM

For a secondment lasting less than three months for foreign employees (continued)

no .	Last Name	First name	Gender	Date of Birth	Nationality
1					
2					
3					
4					
5					
6					
7					
8					
9					
10					

no .	Expiration Date	Service Start Date	Service End Date	Remuneration ⁽¹⁾	Social Security Secondment ⁽²⁾	
1					YES	NO
2					YES	NO
3					YES	NO
4					YES	NO
5					YES	NO
6					YES	NO
7					YES	NO
8					YES	NO
9					YES	NO
10					YES	NO

(1) Gross monthly wage or hourly wage if the secondment is less than one month (in euros). Please note the minimum hourly rate is **€9.43 as of January 1st, 2014**

(2) Circle the appropriate wording.



COMEXPOSIUM

70 avenue du Général de Gaulle

F-92058 Paris La Défense Cedex

Tel: +33 (0)1 76 77 11 11

Fax: +33 (0)1 76 77 12 12

www.comexposium.com