

Relay Controller Module

DESCRIPTION

The Relay Controller Module as described here serves as the host to the Solid State Relay Module (part number WTSSR-M). The Controller can work in conjunction with, or take the place of a PC. It communicates with the Relay Module using its command set in the same way as a PC and allows manual operation of each relay via a remote data link. Switches wired to the inputs of the Controller will be able to set the on/off states of up to 10 relays, two WTSSR-M units.

OPERATION

Connect a power source in the range of 8 to 30VDC to the screw terminals labeled + and - on the board. Connect one end of an RS232 communications link to the port labeled "SLAVE" on the Controller Module, and the other end to the "HOST" port of a Relay Module. To connect switches to the board, run a wire from one of the contact pairs to an input channel, and a wire from the opposite contact to the GND terminal.

Switches wired to input channels A thru E of the Controller Module will control channels A thru E of a Relay Module which has its header character set to address "A". Switches wired to input channels F thru J will control relay channels A thru E of a Relay Module which has its header character set to address "B".

INITIALIZATION

When the Controller Module first powers up, it reads the current state of the switches and sends the appropriate commands to the Relay Module to set each relay so that it matches the state of its corresponding switch. For this initialization procedure to function properly, make sure the communications link and the Relay Module are up and running before applying power to the Controller Module.

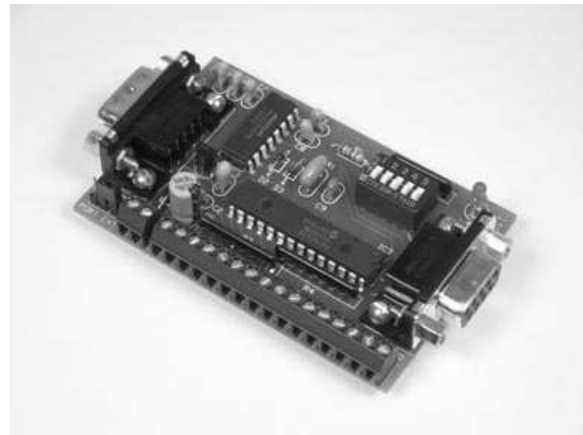

COMMAND VERIFICATION

Each time the Controller Module sends a command to the Relay Module, it listens for an acknowledgment which will indicate that the command was successfully delivered and the Relay Module performed the desired operation. If this response is not received within 20mS, the controller retransmits the command and waits another 20mS. If still no response, it transmits the command one last time and then returns to normal operation. This all happens within 0.06 seconds from the time that the switch was toggled. Note, the Relay Module must have its ECHO turned on to make use of this feature.

CONTACT DEBOUNCE

During switch closure, when the metal plates of a switch first make contact with each other they will bounce several times before coming to rest. Each of the input channels of the Controller Module incorporates its own debounce timer used to mask these multiple transitions. When a switch closure is detected on an input channel, the debounce timer associated with that channel is loaded with a value equal to 0.1 seconds. The input is then disabled until this time period has lapsed. The other inputs are not effected.

HOOKING TO SWITCH CONTACTS

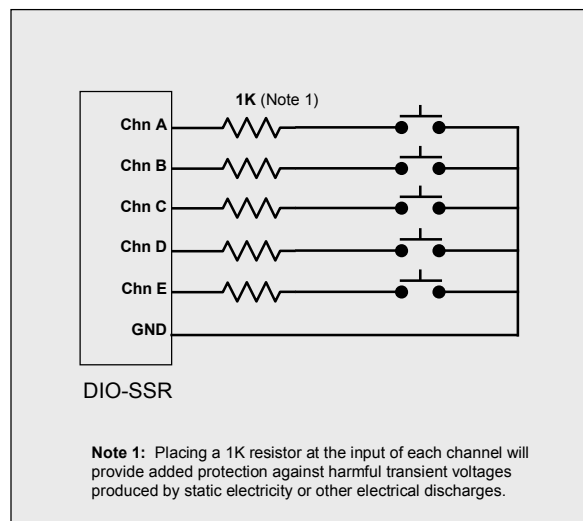

SPECIFICATIONS

Digital Inputs	10 inputs, accepting dry switch contacts.
Buffer Type	7 use Schmitt Trigger, 3 use TTL
Input Clamp Current	±20mA Maximum
Processor	PIC16F882
Clock	4 MHz
Communications	9600 Baud, N, 8, 1
Power Requirements	+8 to +30 VDC
Current Draw	13 to 26 mA
Operating Temperature	-20°C to +80°C
Board Dimensions	3.1" x 2.0" x 0.7"
Weight	1.8 oz

TERMINAL / CONNECTOR DESCRIPTION

NAME	TYPE	ELECTRICAL SPECS	COMMENTS:
HOST	DB9 (female)	EIA/TIA-232E Standard	RS-232 serial port configured as DCE. Connects to host PC. Hardware handshake jumpered.
SLAVE	DB9 (male)	EIA/TIA-232E Standard	RS-232 serial port configured as DTE. Connects to the HOST port of a WTSSR-M. Two WTSSR-M units can be connected.
Power Source	Jumper	N/A	Power source selection jumper. Selects either external, or port powered. (Note 1)
+	Screw Term	+8 to +30 VDC	External unregulated power supply input.
-	Screw Term	GND	External power supply ground.
A – J	Screw Term	V _{IL} = 0 to 0.8V _{TTL} , 0 to 1.0V _{ST} V _{IH} = 2.0 to 5V _{TTL} , 4.0 to 5V _{ST} Max = -0.3 to 5.3V (Note 2)	Will decode logic levels present at the inputs and automatically report any change of state. All channels incorporate a pull-up resistor to 5 volts which will hold it high if left open. A-G = Schmitt Trigger, H-J = TTL.
+5	Screw Term	+5V @ < 100 mA	Regulated 5 volt output.
GND	Screw Term	GND	Logic ground which can be used for the common side of each switch which is connected to an input channel.

Note 1: Selecting "port powered" will draw from the power supply source of an upstream data module. Caution, the COM port of a PC or laptop does not supply enough current to serve as the power supply source.

Note 2: Due to internal 20 mA clamping diodes, a series input resistor will increase the maximum allowable input voltage.

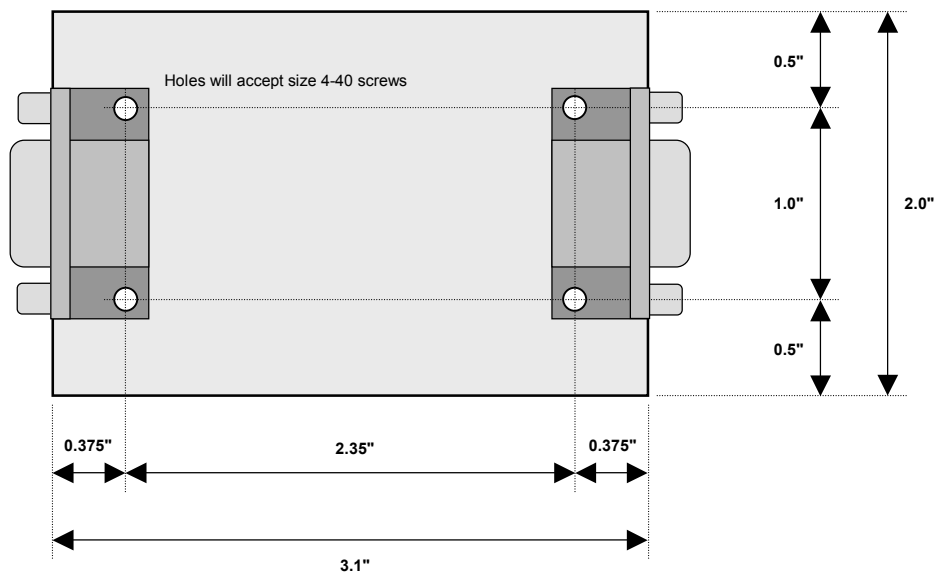
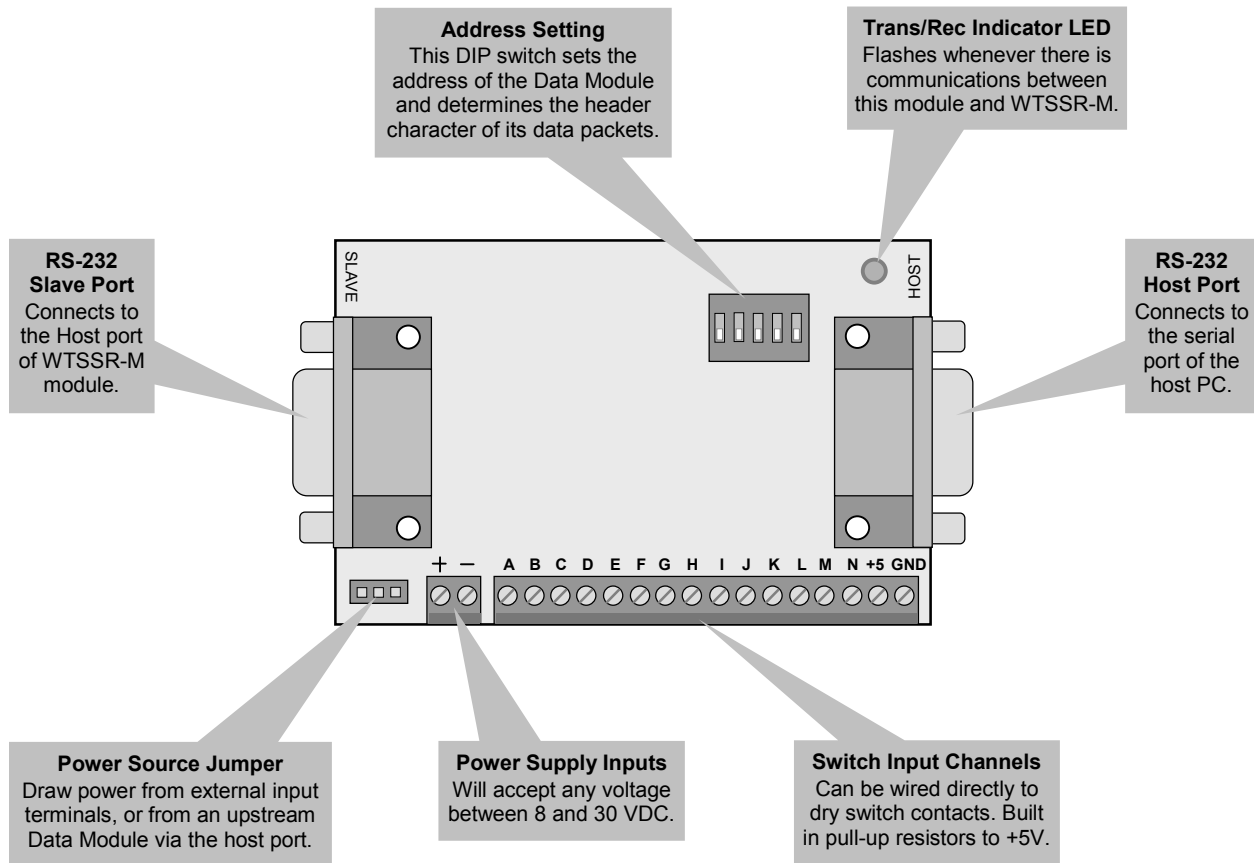

RELAY CONTROLLER MODULE
DIO-SSR

