



Kilsen

KFP-C Series

Intelligent Conventional Fire Detection Systems



A practical overview of product highlights and competitive advantages

The KFP Family

Developed to meet your expectation...
... the intelligent way

The KFP-C Series life safety control systems are part of the KFP family.

The KFP family consists of a range of next generation conventional and addressable fire panels that will support you from small standalone applications such as a small shop or bank, all the way to multi-floor building applications where reliable networking capabilities with central monitoring may be required.

The KFP family will give you all the flexibility to meet your customer's expectations and more. From new projects to expansions to retrofit, everything is possible.

Further in this document we will highlight these benefits as it applies to the KFP-C. For the KFP-A Series life safety control systems, a separate sales guide is available.





Fire Detection Systems

Designed for building owners
Engineered for life safety system suppliers

Kilsen KFP-C fire control panels offer the speed of high-end intelligent processing in configurations that deliver an uncomplicated solution for small to mid-sized conventional applications. They feature an attractive contemporary design that fits with any decor. The gently curved door front offers a distinctive flair with the available finishes. Controls are inset in a striking light grey lexan.

With conventional detection and a full line of easily configured option cards and modules, these quick-to-configure systems offer versatility that benefits building owners and life safety system suppliers alike.

This guide was developed to highlight the strengths of the KFP-C and give those engaged in sales functions an understanding of the many competitive advantages these systems bring to sales calls.

Amongst the strongest selling points the KFP-C offers, is the confidence customers gain by dealing with an identity they've known and trusted all their lives. Kilsen represents a solid foundation for technology and innovations that's been respected for generations. KFP-C fire detection systems are designed for building owners upon this legacy of innovation, and engineered for life safety system installers to exceed the expectations of their customers.

Engineered for fire detection system installers

Quick installation and easy maintenance gives the KFP-C a competitive edge that's good for your bottom line

As a fire detection system supplier, time and money are your primary concerns. You need to know up front what it's going to take to get the system up and running so you can present an accurate and competitive bid to your customer, the building owner. A system that proves difficult to install or that takes more time than anticipated to get a green light from the local authorities, costs you money, risks your business reputation, and can land you in trouble with your customer.

KFP-C fire detection systems are easy to install and quick and easy to service. They work in your favour, keeping installation costs predictable, while contributing to your bottom line - not being a burden on it. With timesaving features not found amongst competing products, these systems will give you the edge you need to stay ahead of the game every step of the way.

What you do with that edge is your business. You can use it to win more bids and land more work, or simply pocket the savings and call it a day. Both outcomes boost revenue, even though moving more systems by passing the savings on to your customer is probably a better long-term business strategy.

Timesaving Highlights for Installers

- Easy system setup and configuration
- Easy-to-configure option cards and modules
- Zone-level fault identification

Benefits for your installers

Quick, easy setup and configuration are vital for your people on the road. Two programming methods are available - basic setup and advanced setup. While KFP-C systems are 100 percent front panel programmable, each method allows the installer to select a programming method that suits the complexity of the tasks at hand. This lets them minimize the amount of time they spend tinkering with the control panel, and focus on getting it up and running in the most efficient way and in the shortest time possible.

Basic programming gets the system up and running quickly and efficiently. With a few easy front panel commands, KFP-C automatically sets system options for factory default operation for the applicable region - this important feature saves time and dramatically simplifies installation and setup.

Front panel programming with the KFP-C's intuitive on-board user interface allows the installer to quickly adjust default settings to accommodate the needs of typical installations.

Advanced programming permits fast incremental changes to settings for site-specific needs. The advanced menus put the power of configuration and diagnostics to work so that installer can easily take full advantage of the KFP-C's well-organized programming engine. Here installers can quickly and efficiently set up the panel, run through programmed settings, and configure option cards and modules.

Installers also benefit from exclusive zone-level fault identification, which takes the guesswork out of troubleshooting. The KFP-C quick-install cabinet allows the wall box to be mounted during building construction while the electronics remain safe and out of harm's way. The one-person walk test speeds the pace of installation.

Time-Saving Highlights for Service Technicians

- Full front panel programming
- Easy diagnostic reporting
- Zone-level fault identification
- Incremental programming

Benefits for your service technicians

Timesaving programming and diagnostics will keep your service revenues up and your labour costs down. With onboard maintenance menus, KFP-C systems can communicate essential fault diagnostic information to the service personnel. This valuable KFP-C innovation allows your technician to do the required maintenance actions on the spot, make programming changes as required - all without needing additional tools or equipment on site.

When a service call is required, your technician can obtain important information such as which zones are in an abnormal state, and even what the cause of this abnormal state is. Having this information dramatically shortens the length of the maintenance call: something both you and your customer will appreciate.

The simplicity built into KFP-C systems makes adding devices or commissioning new zones a breeze for your maintenance personnel. The innovative advanced programming features allow setting up new zones whilst preserving the programming for existing ones. This means that incremental programming is no longer a juggling act - the system takes care of the details, shortening the length of the visit so that more sites can be serviced with the same number of technicians and service vehicles. That makes for a healthier bottom line.

Service and maintenance contracts also represent a significant part of your revenue stream. Frequently the contract is negotiated for a fixed cost over a fixed period, so you want a system that is quick and easy to service. The short and infrequent service calls the KFP-C requires allows you to maintain more systems at more sites with the same number of service technicians and vehicles on the road.

The KFP-C's programming and diagnostic features are a big advantage in this respect and provide opportunities for boosting service revenue while forging good relationships with your customers. This innovation in system communications permits valuable programming and diagnostic operations to be performed whilst on site.

It also offers you the opportunity to provide more responsive service to your customers. Advanced warning gives your service department the opportunity to anticipate problems before your customer's system operation is affected.

Avoidance of emergency service calls fosters a positive relationship between you and the building owner. A good relationship with the building owner not only bodes well when the service contract comes up for renewal, but also gives you an edge when it's time to install, expand, upgrade, or retrofit life safety systems at other properties owned by the same customer.

KFP-C Series

Designed for building owners

KFP-C systems blends seamlessly into the background, providing compliant, trouble-free service long into the future

Building owners and facility managers share your interest in saving installation and maintenance costs. For the owner, the system is a fixture of their building that merits little attention until things go wrong. They fear a system that will be a source of trouble. Amongst their greatest fears is a building constantly being evacuated for no reason. They don't want occupants to be bothered and desensitized to danger by a temperamental alarm system, and they don't want their local authorities on their backs or their fire department imposing fines for unnecessary emergency calls. Revenue and productivity are at stake. KFP-C systems address these concerns through easy operation and easy service.

It's important to stress with building owners the breakthrough in system efficiency that KFP-C systems represent. Intelligent fire detection technology enhances the invisibility of the system from a building owner's perspective. It is more efficient, more reliable, and more stable than other conventional systems. It offers greater flexibility and is less prone to nuisance alarms.

Until now this technology was out of range for most small building applications. This had to do with cost and the complexity of installation and maintenance required by intelligent systems in the past. The KFP-C system offers small building owners a highly efficient means of bringing the advantages of intelligent conventional technology to their properties, helping them manage safer environments with more confidence than ever before.

Quick installation and short service calls for their KFP-C equipment are definite advantages that building owners will appreciate. The fact that this technology virtually eliminates nuisance alarms will frequently tip the balance in favour of intelligent conventional technology over standard conventional systems. The timesaving advantages of the KFP-C over the competition will tip that balance even further.

On top of that we can add the peace of mind that full system certification brings. Third party tested and certified to the stringest requirements of EN54:2, EN54:4 and CPD not withstanding, KFP-C systems carry with it the benefit of EN54:13, allowing overall approval of panels and field devices for complete system compatibility.

Life Simplifying Highlights for Building Owners...

- Easy and intuitive front panel control
- Reduced nuisance alarms
- No need for a fire watch during construction
- Easy maintenance
- Straightforward annual inspections
- Architecturally pleasing panel and device design

Benefits for Building Owners

Building owners and facility managers want to focus on their buildings, not the fire detection system. The worry-free operation of KFP-C systems is a key selling feature for them. The quick setup enjoyed by installers, coupled with the high efficiency gained by service and maintenance personnel makes KFP-C the best choice for small to mid sized building owners today.

Easy and intuitive front panel operation keeps building personnel in control of their KFP-C system. They won't find themselves scrambling for the manual as the system counts down to alarm, and they won't have to call you every time an electrical storm causes a power outage.

KFP-C systems represent fire detection intelligence geared expressly for smaller applications that is the exclusive domain of conventional systems. With KFP-C, building owners now have access to intelligent technology that a short time ago was beyond the reach of most small building budgets.

These intelligent systems offer the building owner a fast and easy way to upgrade from their old cumbersome conventional control panel. In fact, KFP-C control panels can use device wiring from most legacy systems with no adverse effect on performance. This means that the building owner doesn't have to bear the expense of rewiring the building, or endure the disruption it would cause among building occupants.

Building owners also gain the benefit of the KFP-C's ability to provide default alarm operation for detectors installed before the control panel is fully programmed and trouble-free. This valuable KFP-C feature eliminates the expense of a fire watch during building construction.

With automatic drift compensation in the detector offering, the KFP-intelligent conventional detectors adjust sensitivity to compensate for environmental conditions such as dirt and humidity. Meanwhile, programmable sounder outputs eliminate the potential for disruption by providing only a local audible alarm until an event is verified. This feature further reduces the risk of nuisance alarms, avoiding the disruption to building occupants as well as fire department fines that normally result.

Panel diagnostics make annual testing easy and quick. Building occupants are not overrun with testing technicians, and sensitive building areas remain secure.

The clean and easy design approach is carried all the way through to the aesthetics of KFP-C control panels. Their attractive appearance means that they will not be a blemish on an expensive architectural design. Their gently curved door fronts offer a distinctive flair. Controls are discreetly inset on a striking grey lexan.

The line of sleek, low profile detectors complement the overall design appeal of the KFP-C, and that makes the KFP-C system an even more attractive choice for building owners.

The inherent reliability of conventional detection and the proven track record among Kilsen fire detection systems is an assurance to the building owner that their KFP-C control panel will slip quietly into the background the moment the installer leaves the site, and provide fully-compliant, trouble-free service for years to come.

KFP-C Series

Applications

Conventional technology for:

- Schools
- Dormitories
- Nursing homes
- Assisted living
- Hospitals
- Clinics
- Shops and malls
- Restaurants
- Retail facilities
- Cinemas
- Department stores
- Grocery stores
- Office buildings
- Banks
- Child care centres
- Light manufacturing
- Warehousing
- Apartment buildings
- Hotels and motels
- Utilities
- Etc.



Multi-story

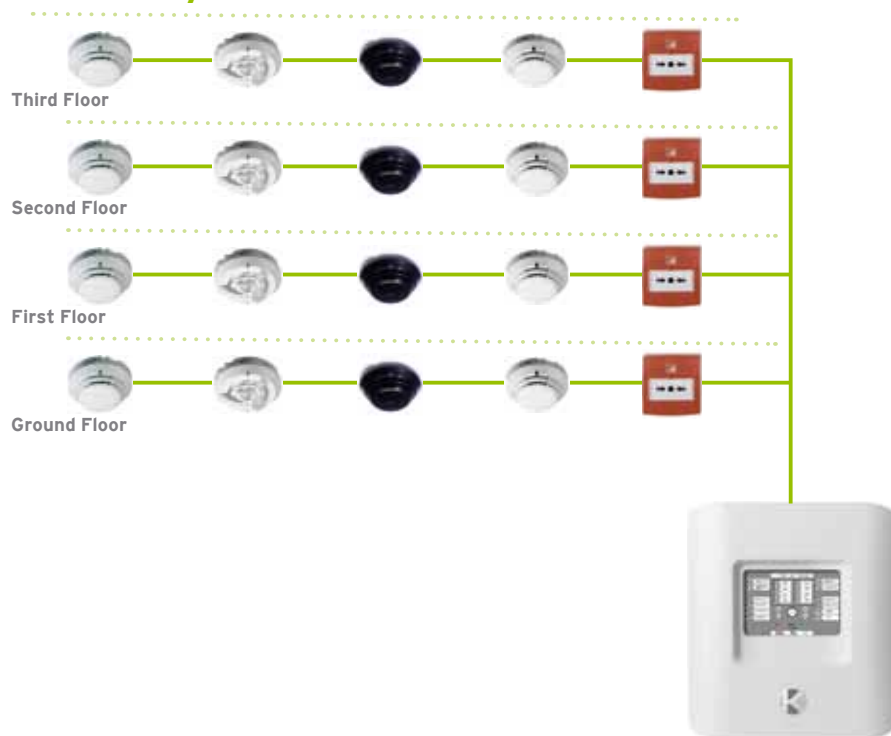

Selling Point Summary

Available Innovation	Selling Point	Primary Audience	
Default alarm operation	No need for an expensive fire watch during building construction. Connect and protect.	End Users, Facility Managers & Building Owners	
Programmable sounder outputs	Provides delayed audible alarm capability when required, reducing building occupant disruption until the event is verified		
Uses existing wiring	Low-cost retrofits without disruptive rewiring		
Up to 256 conventional device points per panel	Large "small system" capacity with room for expansion		
Up to 64 zones networked	Large conventional system applications		
Networking with KFP-A	Integration of conventional and addressable systems		
Class B wiring for detectors	Flexible device configuration for added fault protection		
Detector testing	Simplified annual maintenance requirements		
Intelligent detection	Fast alarm response, reduced nuisance alarms, lower maintenance costs, automatic sensitivity adjustment		
Supervised sounder controls	Built-in synchronised sounder/beacon outputs with front panel controls		Installers
Up to 2 km cable lengths	Cost-effective life safety protection for small and medium protected areas and multi-story buildings		
One-person walk test	Quick verification of system operation		
Quick-install component housing	Easily removable electronics prevents electronics from becoming damaged during installation		
Electronic configuration	No dipswitches to set: faster installation		
Automatic operation mode configuration	Fast setup by operating mode requires no further configuration and reduces the possibility of errors. Quick panel configuration for newly-added devices		
Earth fault detection	Reduces the risk of power supply failures due to faulty wiring		
Front panel programming	Choice of configuration method saves time, simplifies setup		
Fault diagnostics & reporting	Quick service calls	Service Technicians	



Competitive advantages

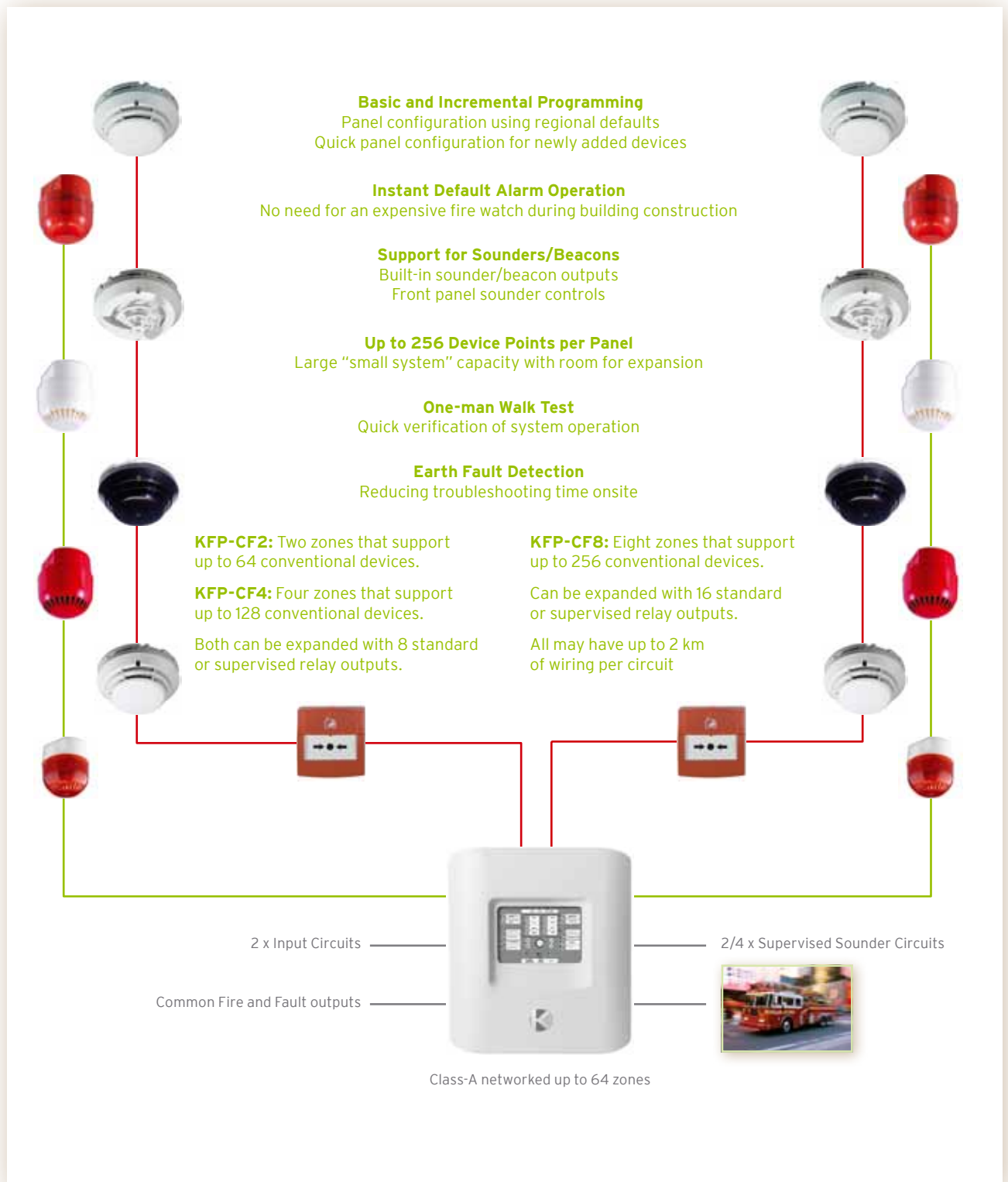

Product summary

KFP-CF2 Fire Control Panel

Supplied in the local language with 2 zones that support up to 64 devices, as well as and 2 supervised relay outputs dedicated to notification control. In addition it includes 2 conventional relay outputs dedicated to common fire and fault conditions, as well as two user configurable inputs for monitoring and control. With option cards the panel outputs may be expanded with an additional 8 supervised or unsupervised relay outputs.

KFP-CF4 Fire Control Panel

Supplied in the local language with 4 zones that support up to 128 devices, as well as and 4 supervised relay outputs dedicated to notification control and fire routing. In addition it has 2 conventional relay outputs dedicated to common fire and fault conditions, as well as two user configurable inputs for monitoring and control. With option cards the panel outputs may be expanded with an additional 8 supervised or unsupervised relay outputs.

Fire Control Panel Networking

The KFP-C allows up to 64 fire zones to be networked in both panel and repeater configurations.

KFP-CE4 Fire & Evacuation Control Panel

Supplied in the local language with 4 zones that support up to 128 devices, as well as 4 supervised relay outputs dedicated to notification control by evacuation area, and 2 supervised relay outputs dedicated to fire routing. In addition it has 2 conventional relay outputs dedicated to common fire and fault conditions, as well as two user configurable inputs for monitoring and control. With option cards the panel outputs may be expanded with an additional 16 supervised or unsupervised relay outputs.

KFP-CF8 Fire Control Panel

Supplied in the local language with 8 zones that support up to 256 devices, as well as and 4 supervised relay outputs dedicated to notification control and fire routing. In addition it has 2 conventional relay outputs dedicated to common fire and fault conditions, as well as two user configurable inputs for monitoring and control. With option cards the panel outputs may be expanded with an additional 16 supervised or unsupervised relay outputs.

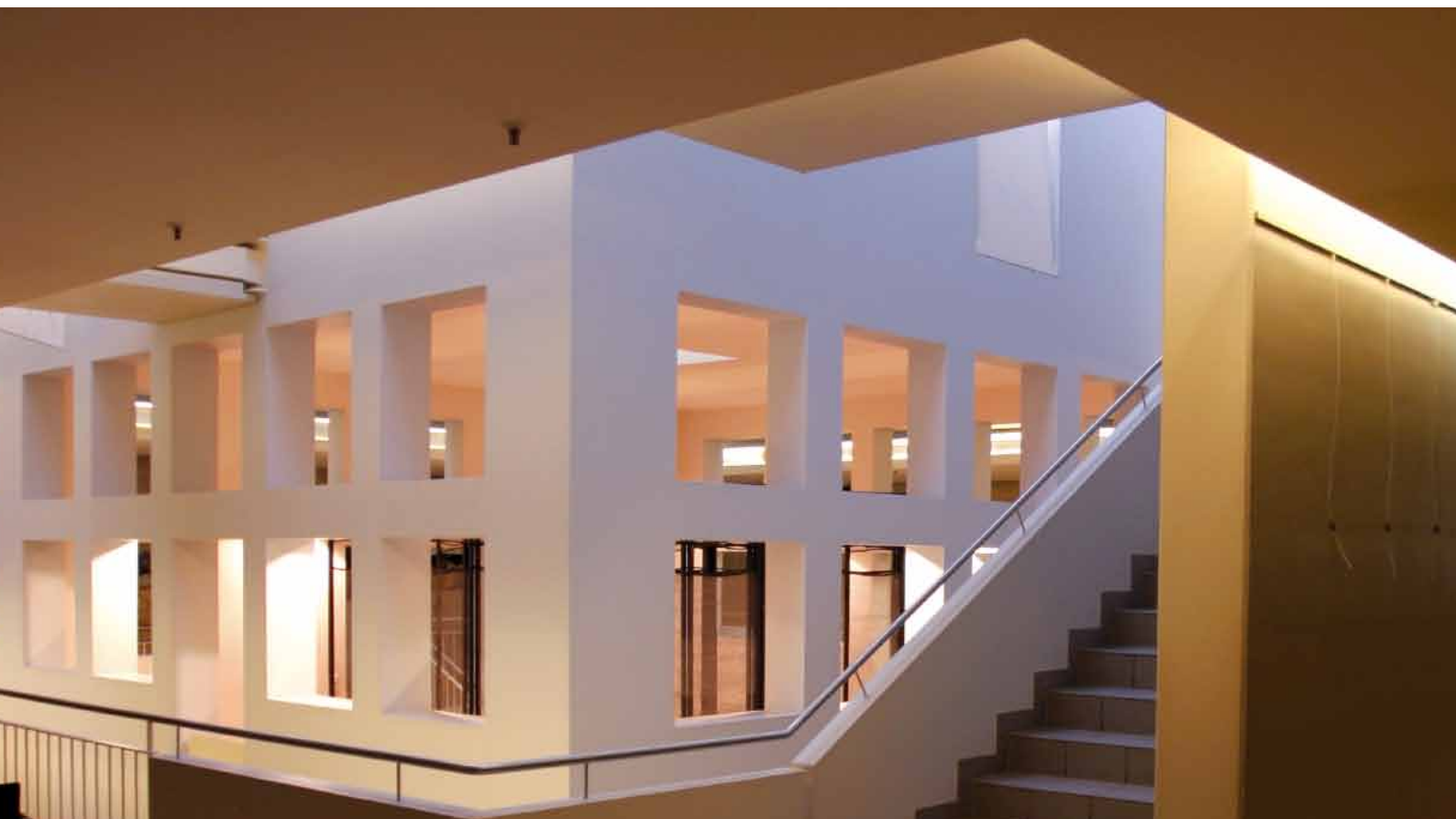



Available Option Cards

- **2010-1-RB** 4 way conventional relay card. Provides 4 C/NO/NC unsupervised relay outputs.
- **2010-1-SB** 4 way supervised relay card. Provides 4 24 VDC supervised relay outputs.
- **2010-1-NB** Network interface for up to 32 nodes

Compatible Detectors & Bases

KL700 Series

- **KZ700** Standard mounting base
- **KZ700B** Standard mounting base (black)
- **KZ705** Standard mounting base with earth terminal
- **KZD705** Deep mounting base
- **KL700** Ionisation smoke detector
- **KL710** Rate-of-rise heat detector (Class A2R)
- **KL731** Optical smoke detector
- **KL731B** Optical smoke detector (black)

Compatible Peripheral Products

Compatible Manual Call Points

DMN700 Series

- **Weatherproof** Red, surface mount with resettable element or glass
- **Indoor** Red or yellow, flush or surface mount, with or without LED, with resettable element or glass

DM800 Series

- **Indoor** Red, metal or plastic call point

Compatible Sounders, Sounder/Beacons and Beacons

- **Sounder** Red or white, fire sounders, multi tone, shallow or deep base
- **Sounder with tamper** White sounder, multi tone, deep base with anti-tamper
- **Sounder/Beacon** Red or white sounder/beacons, multi tone, shallow or deep base
- **Base Sounder** Red or white base sounder, multi tone
- **Outdoor** Red outdoor fire sounder-beacon, high output
- **High Output Sounder** Red fire sounder, multi-tone, high output
- **High Output Sounder/Beacon** Red fire sounder/beacon, multi tone, high output
- **Xenon Beacon** White base, red, yellow or clear lens
- **LED Beacon** Red or white, shallow or deep base, red, yellow or clear lens
- **High Output Xenon Beacon** Red or white, shallow base, red, blue, green, yellow and clear lens

Bells

- **Alarm Bell** 6" or 8", indoor or outdoor

Hazardous Areas

- **Galvanic barriers** For use with AS370/FA370 Series
- **IS Sounder** Red multi tone
- **HA Sounder** Red multi tone
- **IS LED Beacon** Red or clear lens
- **HA Xenon Beacon** Red and yellow lens

Doors Holders and Magnets

- **FE200** 400N, surface, flush, floor or wall mount, square base, with or without release button
- **FE260** 400N, universal adjustable tube, 175mm, 325mm or 475mm
- **FE500** VdS certified, flush, floor or wall mount, square base, standard, weatherproof or explosion-proof

Related Literature

- KFP-C-UM User Manual
- KFP-C-IM Installation and Commissioning Manual
- KFP-C-LF Product Datasheet



Kilsen

KFP-C Series

Distributor: