

Sprint^{SC}

Outdoor

Day & Night IP Camera

User Manual



Revision: 020205

Date: 2009/04/21

For firmware version v020205

Table of Contents

1. INTRODUCTION	6
2. HARDWARE DESCRIPTION AND QUICK INSTALLATION/USAGE	8
2.1. MAJOR HARDWARE COMPONENTS.....	8
2.2. QUICK INSTALLATION AND USAGE.....	9
3. WEB CONFIGURATIONS.....	13
3.1. INFORMATION	14
3.2. VIDEO DISPLAY	15
3.3. NETWORK.....	16
3.4. ADVANCED NETWORK	18
3.5. VIDEO SETTINGS.....	19
3.6. NIGHT MODE CONTROL.....	22
3.7. EMAIL/FTP ALARM.....	23
3.8. DI/DO SETTINGS.....	25
3.9. NAS SETTINGS.....	26
3.10. SCHEDULING	28
3.11. DATE/TIME.....	30
3.12. ADMIN.....	31
3.13. UPGRADE.....	32
3.14. REBOOT.....	34
3.15. SAFE MODE.....	35
3.16. SET TO FACTORY DEFAULT	36
4. FEATURES AND SPECIFICATIONS.....	37
4.1. FEATURES.....	37
4.2. SPECIFICATIONS.....	38
5. PACKAGE CONTENTS.....	40
FIGURE 5-7: INSTALLATION CD APPENDIX A. LIST OF TESTED	
NAT/ROUTER DEVICES.....	40
APPENDIX A. LIST OF TESTED NAT/ROUTER DEVICES.....	41
APPENDIX B. MAXIMUM ALLOWED VIDEO USERS.....	42
APPENDIX C. PERFORMANCE INFORMATION	43
APPENDIX D. TROUBLE SHOOTING	44
APPENDIX E. 3GPP/ISMA OPERATION	45

SprintSc - Outdoor, Day&night IP Camera

APPENDIX F. THIRD PARTY AND EMBEDDED WEB PAGE INTEGRATION.....46

List of Figures and Tables

- Figure 2-1: Major components of the IP camera
- Figure 2-2: IP CAM connection diagram.
- Figure 2-3: The installation CD disk
- Figure 2-4: The ID/Password card
- Figure 2-5: Running window of CamView program
- Figure 2-6: Pop-up play-video password window
- Figure 3-1: Open the web configuration page from CamView software
- Figure 3-2: IP CAM Web configuration login page
- Figure 3-3: IP CAM Information page
- Figure 3-4: Video display page
- Figure 3-5: Network settings page for DHCP function
- Figure 3-6: Network settings page for fixed IP address
- Figure 3-7: Advanced network settings page
- Figure 3-8: Video settings page
- Figure 3-9: 3GPP/RTSP enabled page
- Figure 3-10: Night mode control page
- Figure 3-11: Email/FTP Alarm page
- Figure 3-12: DI/DO Settings page
- Figure 3-13: NAS Storage settings page
- Figure 3-14: Schedule Management page
- Figure 3-15: System date/time settings page
- Figure 3-16: Admin settings page
- Figure 3-17: Firmware upgrade settings page
- Figure 3-18: Firmware upgrade status page
- Figure 3-19: System reboot settings page
- Figure 3-20: System reboot under-going page
- Figure 3-21: Safe mode information page
- Figure 3-22: Press the reset button to set to the factory default
- Figure 5-1: IP Cam body
- Figure 5-2: Power Adaptor
- Figure 5-3: Bracket
- Figure 5-4: Ethernet cable
- Figure 5-5: Quick installation guide
- Figure 5-6: ID/Password Card
- Figure 5-7: Installation CD
- Table A-1: List of tested Wireless AP/router devices

SprintSc - Outdoor, Day&night IP Camera

Table A-2: List of tested Wired NAT/router devices

1. Introduction

The IP Network Camera is designed with the “user-friendly” idea deep in mind. The user can install the IP Camera easily on his/her home network and then access the IP Camera anywhere in the world through the accompanied video management software - CamView without setting some complicated DNS name or changing the router’s settings. It’s just a plug & play action.

With 3GPP/ISMA support, users can see the video of the IP camera on any 3G mobile phone anywhere, anytime. The big difference is that there is software for downloading to the mobile phone so that the fixed IP address is not needed for the IP camera. The video settings including frame rate, resolution and bandwidth could be different for PC monitoring and mobile viewing.

For outdoor surveillance and remote monitoring, the IP Camera provides the best image quality in its class, and excellent performance. It also provides the best bandwidth efficiency, offers 640x480 resolution, 30 fps frame rate, real MPEG4 image compression ability.

With the very low light sensitive sensor and IR led inside the IP66-rated water proof housing, the IP Camera can work day and night and satisfy all security and indoor/outdoor surveillance needs. With the motor controlled IR-cut filter, the day-time video quality is not affected by the infrared light in the sun light. The IR-cut filter is automatically turned on during dark light.

The NAS storage function can easily turn any NAS device to a NVR device. The schedule function provides full scheduling of email/ftp sending, motion detection and NAS recording event. With the built-in Web server, the IP Cameras can also be managed from a standard web browser on a Windows computer or a Macintosh.

The IP Camera provides motion detection function. Users can easily setup this function and receive the notification with the snapshot images through email and/or ftp when some motion events are detected.

The IP camera is ideal for securing small businesses, home offices and residences over a local area network and/or the Internet.

The differences

It’s very easy to see the video of the IP Cam, you only need to key in the ID/Password of the IP CAM any where in the world, you do not need to remember the IP address or domain name or DDNS name or port number. And you do not need to modify the settings(like port mapping, fixed IP, DDNS, virtual server) of the NAT/router

SprintSc - Outdoor, Day&night IP Camera

devices, it's just a plug & play usage.

So, the differences are the followings:

- ◆ **Public IP address needed ?** **No**
- ◆ **Dynamic DNS needed ?** **No**
- ◆ **Port mapping in router?** **No**
- ◆ **Virtual server in router ?** **No**
- ◆ **UPnP support in router ?** **No**
- ◆ **What's needed ?** **ID and Password**

2. Hardware description and quick installation/usage

The IP CAM is designed to be very easy to install and use. First, let's see the major components of the IP CAM products.

2.1. Major hardware components.

The major components of the IP CAM products are listed below :

1. Lens – the focus of the lens is fixed, you do not need to spend time to adjust the focus, the effective focus range is from 30cm to infinity.
2. IR LEDs – there are totally 36 IR LEDs that can provide approximately 30m distance night vision.
3. Light detector – this light detector can detect when the light is becoming dark and turn on the IR LEDs automatically.
4. Power jack – this is the place to plug in the power adaptor. The power needed for this IP CAM is 12V/1.0A, please make sure you are using the correct power adaptor.
5. Ethernet jack – this is the place to plug in the RJ45 Ethernet cable.
6. Reset button – this is the button to reset the IP CAM to default factory settings. You need to press the reset button for more than 4 seconds to enable the reset function. Usually when you forgot the administrator account, you will probably need to do this reset action to reset to the default factory settings. Please refer to section 3.16 for more details.
7. Digital input terminal block – this is for alarm detection, an open circuit is off, a close circuit is on.
8. Status indication LED (red) – this LED is to indicate the Internet connection status. When the Internet connection is connected, the LED will be constant red light. If there is any Internet connection problem, the LED will be blinking red light.
9. Ethernet indication LED (blue) – this LED is to indicate if the Ethernet link is ok and packet traffic is sending/receiving. When the Ethernet cable is connected, the LED is constant blue light. When there is packet sending/receiving, the LED is blinking blue light.

SprintSc - Outdoor, Day&night IP Camera

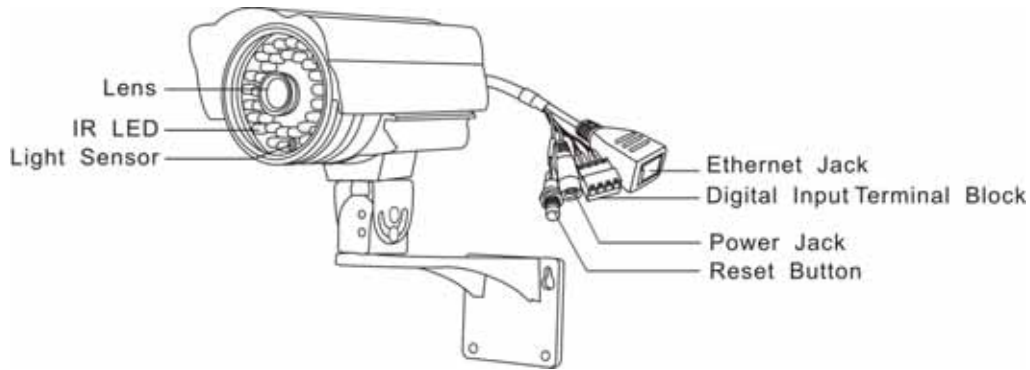

Figure 2-1: Major components of the IP camera

2.2. Quick installation and usage

There are only three things that you need to do to see the video from the IP CAM.

1. Connect the IP CAM to the home/office network.
2. Install the CamView software on the notebook/PC.
3. Key in the ID/password of the IP CAM(from the ID/Password card) on the CamView, and then you can see the video.

First, Connect the IP CAM to the home/office network

Please connect the IP CAM accessories to the IP CAM body correctly, including the bracket, power adapter and Ethernet cable, as shown in Figure 2-2. And connect the other end of the Ethernet cable to the home network or office network. Usually, this Ethernet cable is plugged into a home NAT/router device or an Ethernet switch if in the office, as shown in Figure 2-2. Since the default settings of the IP CAM use DHCP function and very often there is a DHCP server on most of the Home/office network, the IP CAM should be connected to the Internet immediately.

SprintSc - Outdoor, Day&night IP Camera

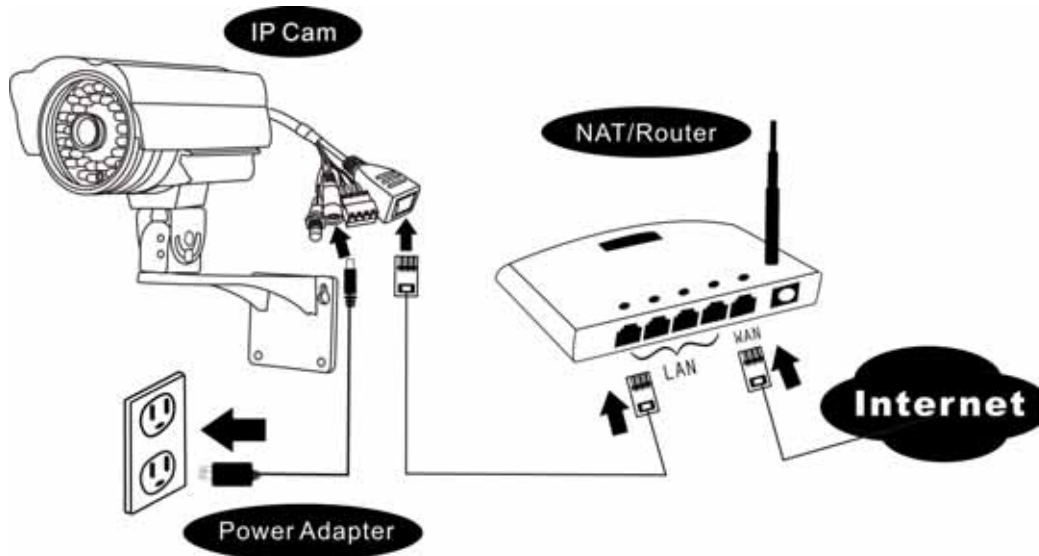

Figure 2-2: IP CAM connection diagram.

Second, Install the CamView software on the notebook/PC

Please insert the installation CD into the CD-ROM drive in your notebook or personal computer (must be running Microsoft Windows OS). Execute the program CamViewInstaller-xxx.exe on the disk. The program will pop-up some windows about the installation options, please press the “next” button to proceed with the installation. After the installation is complete, there will be a CamView icon on the desktop of your computer screen, please execute this icon. The CamView program will run immediately.



Figure 2-3: The installation CD disk

Third, Use CamView program to see the video

Figure 2-5 is the running window of the CamView program. If the computer and IP CAM is connected to the same network, the IP CAM ID will be displayed in the “Auto Search” list. You can double click the “Auto Search” to search all the connected IP CAMs any time. The only thing left right now for seeing the video is to double click

SprintSc - Outdoor, Day&night IP Camera

the IP CAM ID item in the “Auto Search” list. For example, if the IP CAM ID is 001-001-029, you can then double click the 001001029 item in the “Auto Search” list to view the video. A window asking for password input will pop up. Please key-in the password in your ID/Password card into this field and click “ok”. The video will then be displayed on the window.



Figure 2-4: The ID/Password card

Notice :

1. You can modify this play-video password by entering into the web configuration pages. Please refer to section 3.6 for more information.
2. You can also add the IP CAM into the CameraList in the CamView software to have more convenient video display, please refer to the user manual of the CamView software for more functions.

Seeing the video in a remote location

After the IP CAM is installed and you can see the video from the CamView software in the local network, it's very easy to see the video in a remote location. All you need to do is add a camera item in the “CameraList” folder of the CamView software, key in the IP CAM ID and Password(from the ID/Password card). And then double click this camera item. You will then see the Camera video immediately. No further NAT/router setting modifications are needed.

SprintSc - Outdoor, Day&night IP Camera

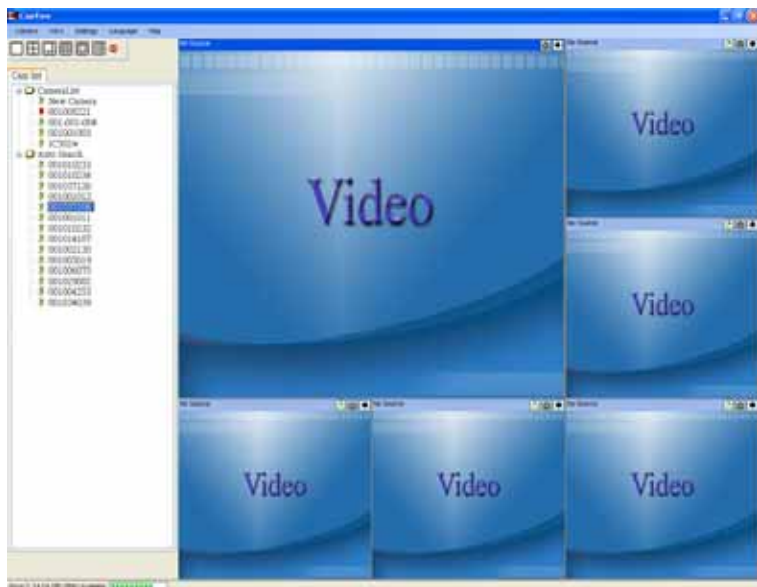

Figure 2-5: Running window of CamView program

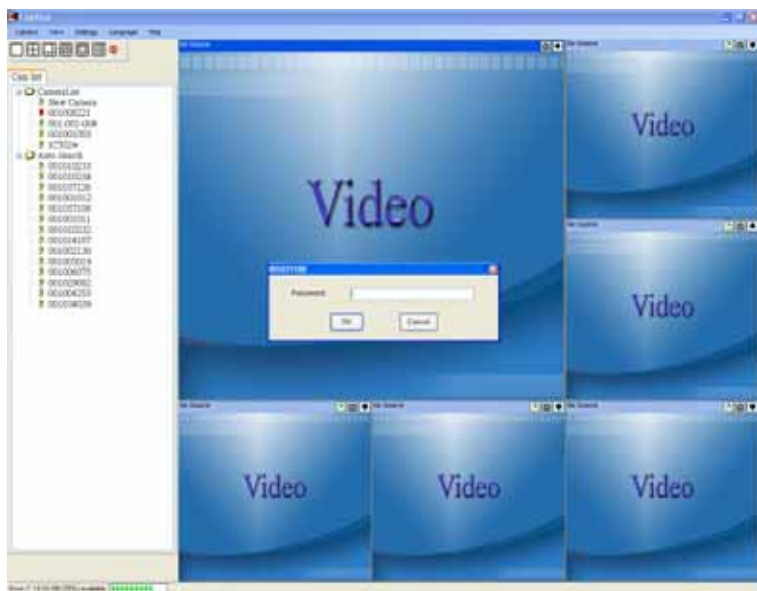

Figure 2-6: Pop-up play-video password window

3. Web configurations

You can login into the web configuration page by directly key-in the IP address of the IP CAM or right-click the searched IP CAM in the “Auto Search” list of the CamView software and click the “Web Configure” to open the login window of the IP CAM.

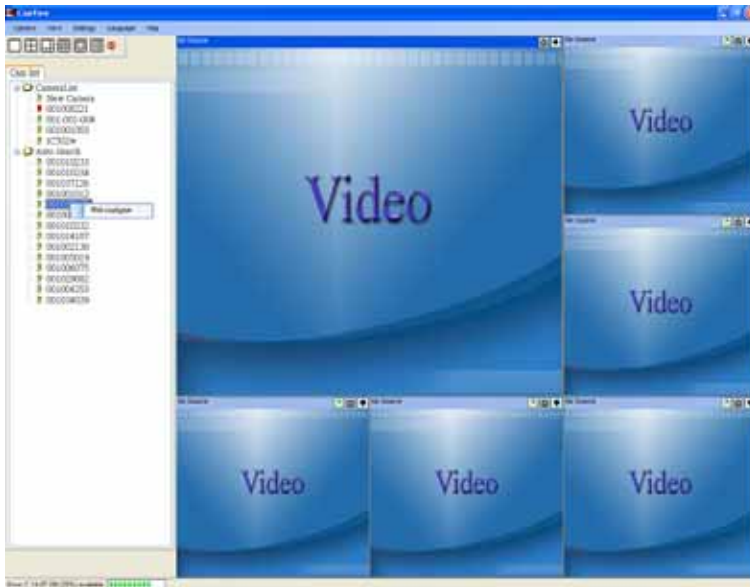

Figure 3-1: Open the web configuration page from CamView software

The default login account is “admin”, leave the Password field empty.



Figure 3-2: IP CAM Web configuration login page

3.1. Information

The first page of the web configuration of the IP CAM is the information page. You can see the model name/firmware version, IP CAM ID, registration status, network type and current video settings(bandwidth, resolution) in this page.

The IP CAM can be viewed remotely by the CamView software only when the IP CAM is registered. If this IP CAM is not registered, please check the Ethernet wiring of your network environment. The “Network type” field displays the network connection(wired or wireless) and method(DHCP, PPPoE or static ip) the IP CAM is running. The “Video users” field displays the number of connected video viewing users.



The screenshot shows the web configuration interface for an Outdoor IP Camera. The top banner features a camera icon and the text "Seeing the video from anywhere". Below the banner is a navigation menu with options: Information, Network, Video, Schedule, and Admin. A language dropdown menu is set to "English". The main content area is titled "IP CAM Information" and displays the following data:

IP CAM Information	
Model	wired / v020201
IP CAM ID	001-037-091
Registration status	Registered(3)
Network type	Wired(DHCP) - (ip=10.10.10.173)
Video user	0
Video resolution	640 x 480
Video bandwidth	512K bps
Email/Ip Alarm	On
NAS Record	Not Recording
Mac Address(Hex)	00:1B:C7:00:24:5A

Figure 3-3: IP CAM Information page

3.2. Video Display

This display page allows you to view the video display of the IP camera. For the first time use of this display on a computer, an activeX component will be automatically downloaded into the browser. This could take some time, depends on the internet speed. The component is downloaded from a public domain, so that the computer must be connected to the Internet.

If you want to modify the video display screen size, please refer to section 3.6 for more details.

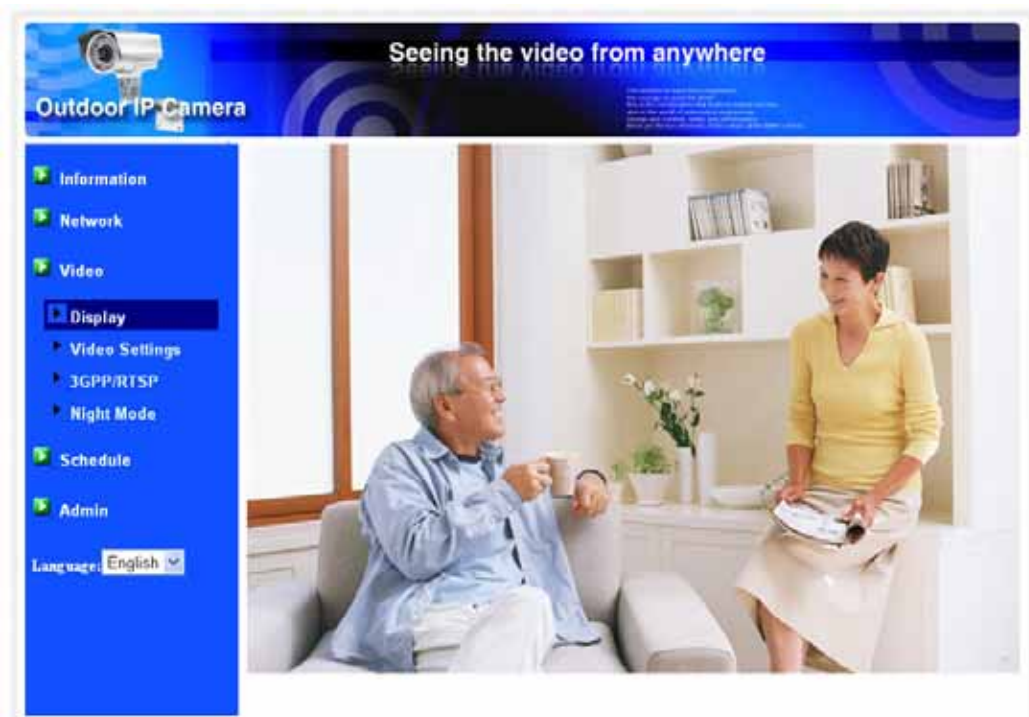

Figure 3-4: Video display page

3.3. Network

The Network page allows you to modify the network settings of the wired Ethernet. The default settings use DHCP to obtain an IP address automatically. In most of the home and office network environment, there is a DHCP server running. In this situation, by using this default settings, the IP CAM can work immediately in most of the time.

If the Ethernet cable is unplugged, the IP CAM will lose connection. But as soon as the Ethernet cable is plugged in again, the IP CAM will obtain a new IP address immediately.

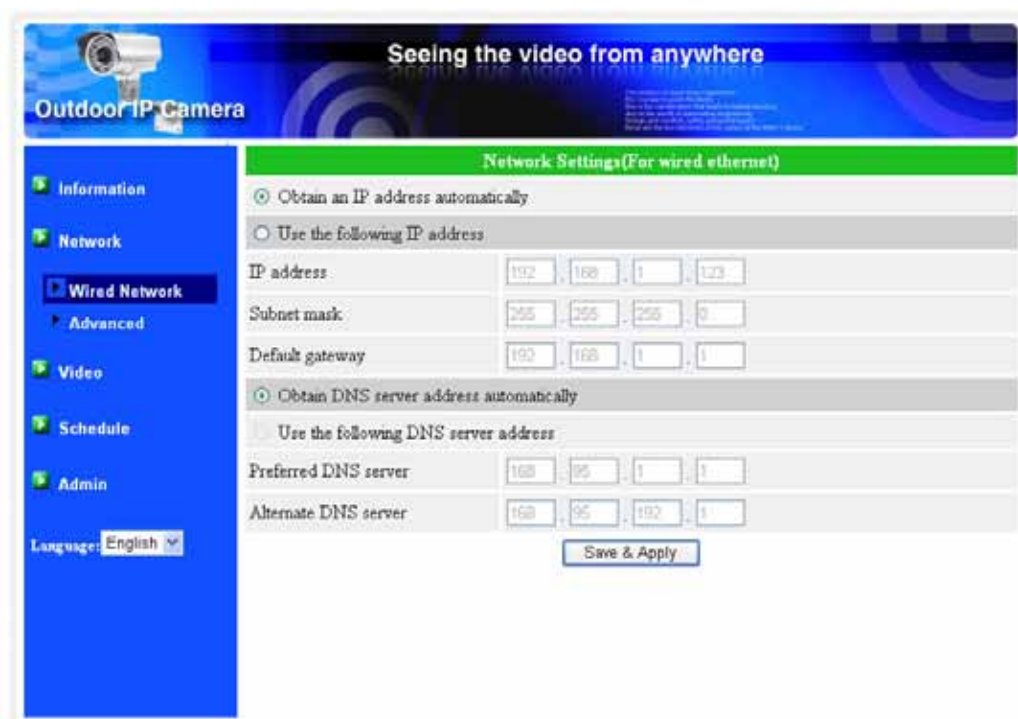

Figure 3-5: Network settings page for DHCP function

If the network environment does not support DHCP function, you will need to set the network settings of the IP CAM manually. Please fill all the fields including “IP address”, “Subnet mask”, “Default gateway” and “DNS server” to let the network work. All these settings must be correct for your network environment, otherwise the IP CAM can not work.

The default setting is “Obtain an IP address automatically”.

SprintSc - Outdoor, Day&night IP Camera

Seeing the video from anywhere

Outdoor IP Camera

Information

Network

Wired Network

Advanced

Video

Schedule

Admin

Language: English

Network Settings (For wired ethernet)

Obtain an IP address automatically

Use the following IP address

IP address: 192 . 168 . 1 . 123

Subnet mask: 255 . 255 . 255 . 0

Default gateway: 192 . 168 . 1 . 1

Obtain DNS server address automatically

Use the following DNS server address

Preferred DNS server: 168 . 95 . 1 . 1

Alternate DNS server: 168 . 95 . 192 . 1

Save & Apply

Figure 3-6: Network settings page for fixed IP address

3.4. Advanced Network

In some special situation, your network environment only provides PPPoE connection(ADSL service), there is no NAT/router available. You will then need to set the PPPoE settings in the “Advanced Network” page. Only the PPPoE username and password are needed to let PPPoE work. After the “Save&Apply” button is pressed, the PPPoE function will work immediately. You can check the “Registration status” in the “Information” page to see if the IP CAM is registered using the PPPoE connection.

Please be noticed that the DHCP or static IP settings in the “Network” page can work together with the PPPoE connection. Only that the PPPoE has higher priority, so, if the PPPoE is working, the IP CAM will use PPPoE to connect to the Internet.

The default setting is “Disable PPPoE”.

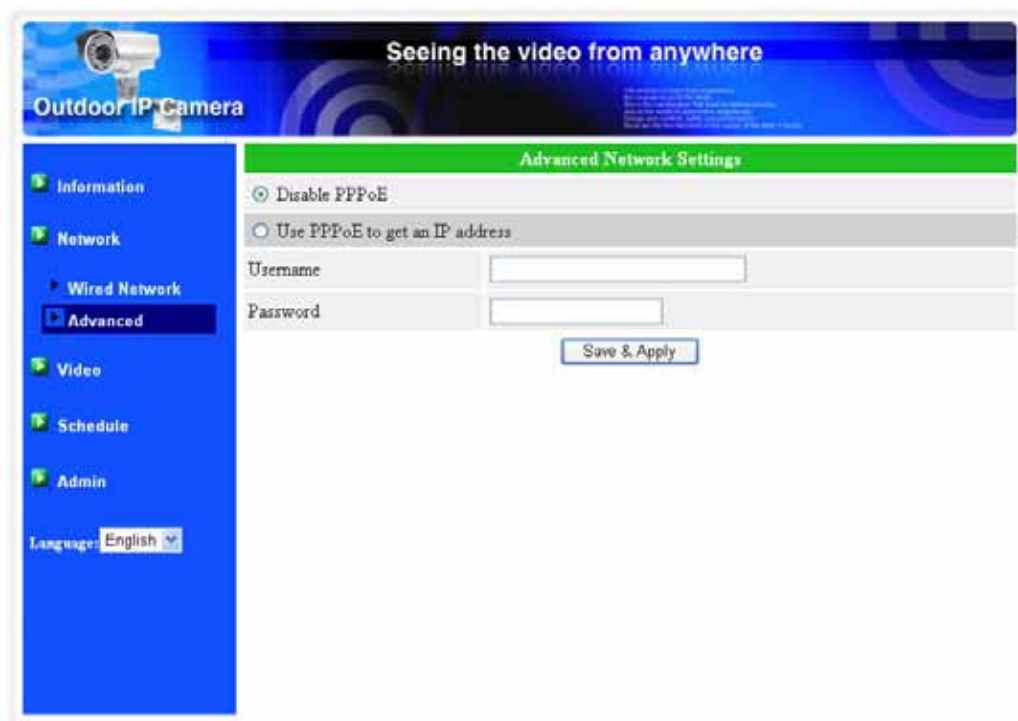

Figure 3-7: Advanced network settings page

3.5. Video Settings

The IP CAM is designed to provide high quality video for viewing from CamView software. In this page, you can modify some settings related to the video viewing:

1. Password(play video) – this is the password needed for viewing the video from the CamView software. Together with the IP CAM ID, you can view the video of this IP CAM anywhere in the world through the Internet.
2. Internet speed – this is the Internet bandwidth of your network environment. Higher value will generate higher video quality. But if your internet connection can not provide more bandwidth than the specified value, the video quality could degrade. So, please key in a value that is lower than your internet bandwidth.
3. Select resolution & frame rate automatically – you can let the system select the suitable video resolution and frame rate automatically for you. The selection is based on the “Internet speed” value. This is the recommended default setting.
4. Resolution – there are three choices : 160x120, 320x240 and 640x480. If you decide to choose the value manually, you can choose one of the three values. But, please be noticed that if the Internet speed is slow(low value), high resolution(640x480) or frame rate could cause very bad video quality.
5. Frame rate – the video frame display rate. Higher value means faster movement and continuity in the video display.
6. Favor/Preference – choose between “Video motion” and “Image quality”. When the real bandwidth is not enough for the selected “Internet speed”, the system will need to degrade the video motion or image quality. This selection will decide if the user want to maintain the “video motion” or “image quality” when the internet speed is not good enough.
7. Brightness – the brightness of the video, lower value means darker display.
8. Sharpness – the sharpness of the video, higher value means sharper video.
9. Low light sensitivity – The low light sensitivity could be normal, high or very high. When the low light sensitivity is high, the system could see better video clearance under low light situation, but the moving object will not be very clear under this low light environment. Under very dark environment, set to “very high” will get better video clearance. The default value of this setting is “high”.
10. Video color – choose between “colored” and “black&white”.
11. Outdoor/Indoor video – for better video display quality, modify this setting when taking indoor or outdoor video. The default setting is “Outdoor video”, in most cases, this is also ok for indoor usage. Under some special cases, there could be some strip lines on the video display when the IP camera is taking indoor video. In this situation, change the setting to “Indoor video” will solve the problem. Please also be noticed that in “Indoor video” setting, the video display of outdoor view is

SprintSc - Outdoor, Day&night IP Camera

very vague. For indoor usage, if there is strong sun light into the room, please select the “Indoor+sun light” choice.

12. Enable/disable time display on video – if enabled, the date/time of the system will be displayed on the left-upper corner of the video.

When this modification is “Save&Apply”ed, it works immediately, but all the connected video viewing users will be disconnected.



Figure 3-8: Video settings page

3GPP/RTSP settings

The IP CAM is able to be viewed from a 3G mobile phone, for detailed settings on the 3G mobile phone, please refer to Appendix E.

Users can disable the 3G mobile access ability in this page. After the 3GPP/RTSP feature is disabled, no 3G mobile phone is allowed to access the video of the IP camera. When this is disabled, the rtsp stream with MPEG2 audio is still working, please refer to Appendix F for more details about rtsp stream with MPEG2 audio.

When the 3GPP is enabled, the video frame rate, resolution and bandwidth for 3G mobile access could be set independently from the video settings for CamView(PC) access. The maximum allowed resolution is 352x255 and maximum allowed bandwidth is 256 kbps.

The "Access URL" line is the url address for 3G mobile phone to input for seeing the video of the IP camera. Different 3G mobile may need to input this url in different way, detailed information could be found in the user manual of different 3G mobiles. Please be noticed that usually public IP address is needed for the IP camera, so that the 3G mobile could access the IP camera's video.

The default setting is "Enable 3GPP/RTSP".

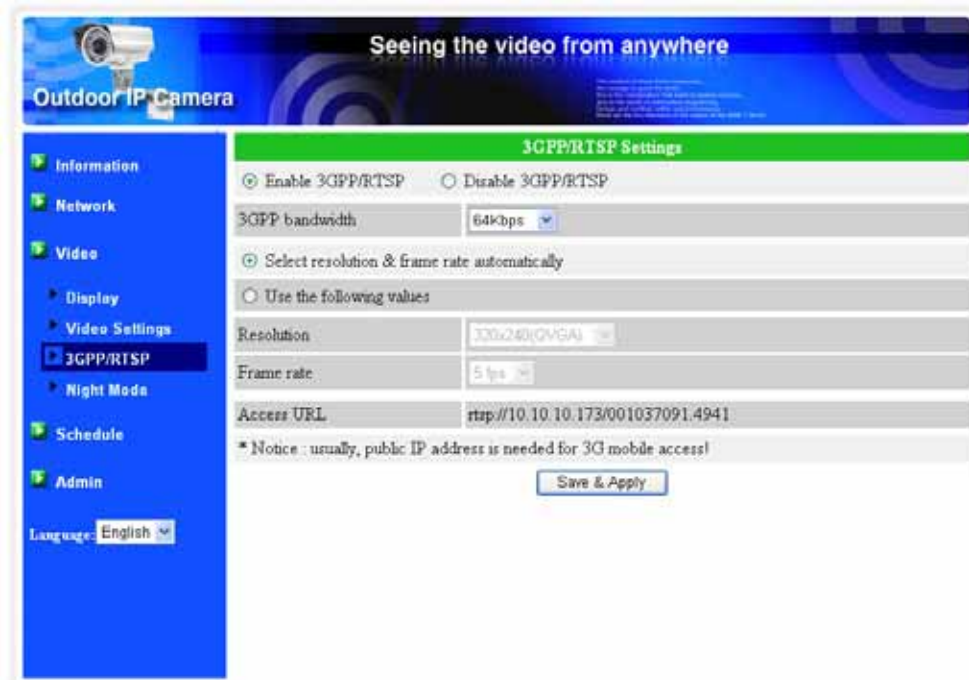

Figure 3-9: 3GPP/RTSP enabled page

3.6. Night mode control

The IP Cam is able to work both in day time and night time. There are some IR LEDs that can let the IP camera see the objects in the night time. Users can adjust the numbers of the IR LEDs according to the view sight distance during night mode to get the best night mode vision. The night mode status is also displayed.

This night mode control page is to control when the time the IR LEDs will be on. There are three ways to control the night mode(IR LEDs) :

1. Automatic day and night mode switch : the IP cam will automatically turn on the IR LEDs when the night time is arrived or the environment is becoming dark. There is a light sensor on the IP cam that is doing this light detection.
2. Scheduled time of night mode : the IP Cam can also be scheduled to turn on the IR LEDs in a time range of each day.
3. Manual night mode control : the IP Cam can be manually forced to night mode(IR LEDs on) or day mode(IR LEDs off).

In order to get better video color display during day time and night time, there is an ICR(IR Cutter Remover) in the IP Cam. This ICR will be controlled automatically to filter out the IR(Infrared) light during the day time and allow the IR light to pass during the night time. This make sure the video color quality is excellent compared to other IP camera.

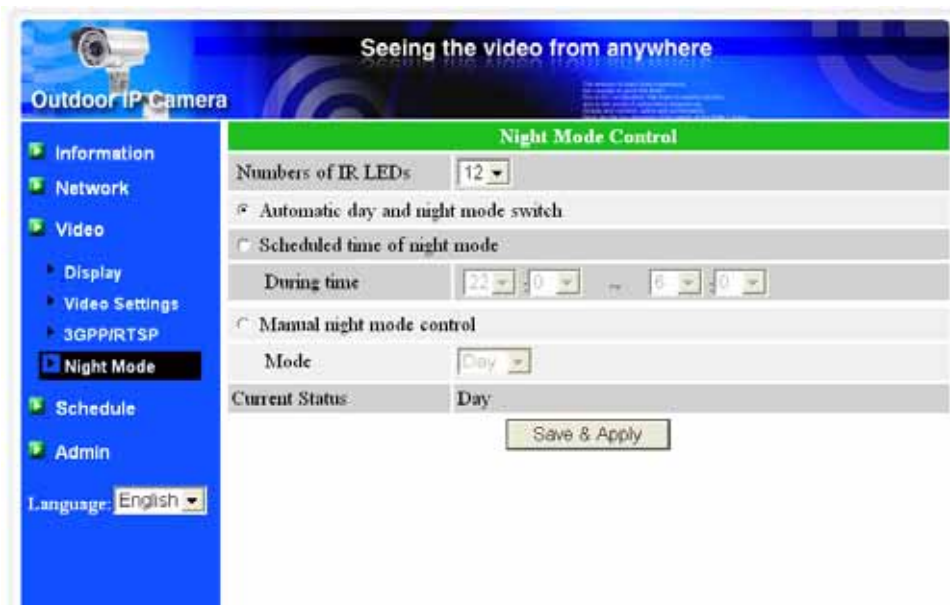

Figure 3-10: Night mode control page.

3.7. Email/FTP Alarm

The IP CAM provides the Email/ftp function, you can enable or schedule the Email/ftp ability in this page, the IP CAM will then send out an email with a jpeg picture attached in the email and/or send out the jpeg picture file to a ftp server. The related settings are explained below:

1. Email/FTP trigger – choose between “motion”, “D/I”, “schedule” and “disable”
 - A. If “motion” is selected, it means that when there is a motion detected, the system will send out the email and/or ftp with the captured video snapshot.
 - B. If “D/I” is selected, it means that when there is a Digital input alarm detected, the system will send out the email and/or ftp with the captured video snapshot. If the D/I alarm is constantly on, the IP camera will keep sending out email/ftp message every second for up to 30 seconds.
 - C. If “schedule” is selected, it means that the email/ftp alarm detection and triggering will be scheduled by the “scheduling” in section 3.9.
 - D. “disable” will disable the email/ftp alarm.

2. Motion sensitivity – there are three possible choices in this field.

“High” means high sensitivity, i.e., the detection is triggered by a very small movement in the video image. If “High” is selected and the size of the moving object is larger than about 1% of the whole video area, it is detected. Please be noticed that the real size of the object could be large or small, anyway, the detection is only based on the relative size of the object. Probably a small pencil moving near the IP CAM could be detected, but a moving car far away from the IP CAM could not be detected.

“Low” means low sensitivity, i.e., the detection is triggered by a very large movement. If the size of the moving object is larger than about 10% of the whole video area, it is detected. “Median” means 3% to trigger the detection.

3. Send email message – if this item is enabled, the IP CAM will send out an email message with the jpeg picture attached to the specified email account.

4. Email recipient – this is the email address to receive the detection notice message. An email message with the jpeg picture file named by the date/time of the triggered moment will reach this address.

5. SMTP server – this is the SMTP server that will help to transfer the email message. This server is irrelevant to the “Email recipient” address.

6. SMTP username/password – this is the account to use the SMTP server to transfer the email message. The SMTP server and username/password account are only for transfer the email message to the “Email recipient”, the “Email recipient” could be on another email server or any reachable email address. The

SprintSc - Outdoor, Day&night IP Camera

username and password fields could be left empty if no authentication is needed for the SMTP server.

7. SMTP server test – after the settings are filled, you could press “SMTP server test” to check if all the settings are correct.
8. Send FTP message – if this item is enabled, the IP CAM will send out a jpeg picture file to the specified ftp account.
9. FTP server – this is the FTP server address to receive the jpeg file.
10. FTP username/password – this is the username/password to login into the FTP server, so, this triggered jpeg file will be allowed to reach this FTP server.
11. Remote folder – the jpeg file will be put under this folder of the FTP server.

When this modification is “Save&Apply”ed, it works immediately, but all the connected video viewing users will be disconnected.

The default setting is “Disable”.



The screenshot shows the 'Email/FTP Alarm Settings' page. The page has a blue header with the text 'Seeing the video from anywhere' and 'Outdoor IP Camera'. A left sidebar contains navigation links: Information, Network, Video, Schedule, Email/ftp Alarm (selected), NAS Settings, Scheduling, and Admin. Below the sidebar is a 'Language' dropdown set to 'English'. The main content area is titled 'Email/FTP Alarm Settings' and contains the following fields and controls:

- Email/FTP Trigger:** Radio buttons for Motion (selected), DVI, Schedule, and Disable.
- Motion sensitivity:** A dropdown menu set to 'medium'.
- Send Email message:** A checked checkbox.
- Send FTP message:** An unchecked checkbox.
- Email recipient:** Text input field containing 'test@test.com'.
- SMTP server:** Text input field containing 'test.com' and a 'port' field containing '25'.
- SMTP Username:** Text input field containing 'test@test.com'.
- SMTP Password:** Password input field with four asterisks.
- FTP Server:** Empty text input field.
- Username:** Empty text input field.
- Password:** Empty password input field.
- Remote folder:** Empty text input field.

At the bottom of the form are two buttons: 'Save & Apply' and 'SMTP server test'.

Figure 3-11: Email/FTP Alarm page

3.8. DI/DO settings

The IP camera provides DI alarm detection function. The related settings are explained below:

1. Digital input – can select the normal status of the digital input as either open circuit or closed circuit. The current status is also displayed. An active status could trigger the email/ftp or the NAS/SD card recording by setting the scheduling.

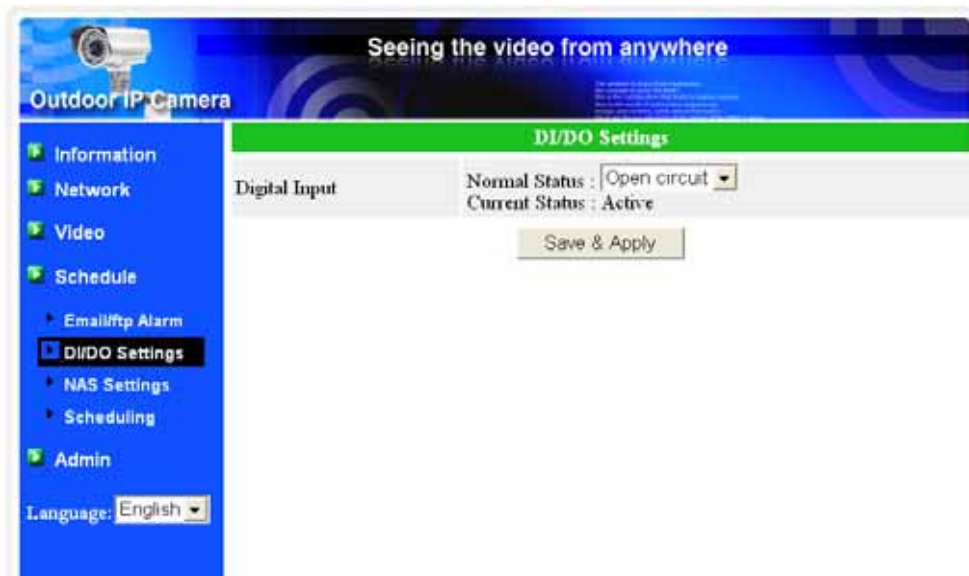

Figure 3-12: DI/DO Settings page

3.9. NAS settings

The IP Camera provides the recording of the video files into a standard NAS (Network Access Storage) device. The IP camera connects to the NAS device using the standard LMX_NS/CIFS/SSN protocols that are the same as the Microsoft Windows network neighborhood protocols. This makes the IP camera easily record the video files to all the standard NAS devices in the market. Since there are a lot of different choices, including prices and scales, users can decide by themselves which is best for their needs. By using this function, the standard NAS device is becoming a NVR (Network Video Recorder) device.

Notice : when the IP camera is doing NAS recording, this is counted as one video user. Please refer to appendix B about allowed maximum video users.

1. If the “Always Recording” is selected, the system will start to record to the NAS storage device immediately and keep recording always. If the “Schedule Recording” is selected, the system will do the NAS recording according to the “scheduling” in section 3.10. “Disable Recording” will disable this NAS recording.
2. When doing the NAS recording, the system will check the free disk space of the NAS device. If the free disk space is less than the specified number, the system will do “Circular recording”(overwrite the oldest recorded files of this ip camera in the NAS device) or “Stop recording” as selected. If the “keep recorded video for xx days” is selected, the system will do circular recording and over write the recorded video files older than xx days ago.
3. The IP camera can connect to the NAS device by using the “NAS name” or “NAS IP address”. If the NAS device and the IP camera are in the same local area network, the IP camera can automatically locate and connect to the NAS device by the “NAS name”. If the NAS device uses a fixed IP address(either in the local area network or in the public internet), the IP camera can connect to it by the “NAS IP address”.
4. The “Shared folder name” is the folder in the NAS device that will record the video files of the IP camera.
5. The “NAS access account” and “NAS access password” are the username and password to login into the specified “Shared folder name” of the NAS device.

In the Microsoft Windows environment, you can access to the NAS device by keying the URL address [\\“NAS name”\“shared folder name”](#) or [\\“NAS IP address”\“shared folder name”](#) in the windows Internet Explorer, and then key in the “NAS access account” and “NAS access password” to the prompted login window. The video files are recorded under the subfolder IPCamRecordFiles/Recording/ID-ID,

SprintSc - Outdoor, Day&night IP Camera

where ID is the ID of this IP camera. All the recorded files are with the name of hhmmss.crf format, where hh is the hour, mm is the minute, ss is the second of the starting time of the recording video. The files are segmented every five minutes. Users can use the free bundled CamPlay software to play back the video files.

The screenshot shows the 'NAS Storage Settings' page of the SprintSc web interface. The page has a blue header with the text 'Seeing the video from anywhere' and 'Outdoor IP Camera'. A left sidebar contains a menu with options: Information, Network, Video, Schedule, Emailftp Alarm, D/DO Settings, NAS Settings (highlighted), Scheduling, and Admin. Below the menu is a language dropdown set to 'English'. The main content area is titled 'NAS Storage Settings' and contains the following settings:

- Recording mode: Always Recording, Schedule Recording, Disable Recording
- Keep recorded video for: 3 days (Circular recording)
- Free disk threshold: GB, with options Circular recording and Stop recording
- Use NAS name: (selected)
- Use NAS IP address:
- Shared folder name:
- NAS access account:
- NAS access password:

A 'Save & Apply' button is located at the bottom right of the settings area.

Figure 3-13: NAS Storage Settings page

3.10. Scheduling

The IP Camera provides the scheduling function for the motion detection triggered email/ftp sending and/or the NAS recording with the individual parameters set in the . “Email/ftp alarm” settings and the “NAS settings” page. Totally 12 schedule list items are allowed. There is no conflict check for the scheduling, it means that the scheduling time could be overlapped, and the IP camera will do all the scheduled events during the overlapped time period. For the scheduling of the Email/ftp sending and/or NAS recording, the “Schedule” option must enabled in the “Email/ftp alarm” settings and/or the “NAS settings”.

1. Schedule list – all the scheduling are listed in this area. Each listed item can be modified or deleted by pressing the “Edit” or “Delete” button.
2. Email/ftp Alarm – for each scheduling, if this is selected and the “Motion triggered” and/or “D/I triggered” is enabled, the IP camera will trigger the email/ftp sending in the scheduled time period when the video motion is detected and/or digital input alarm is detected.
3. NAS Record – for each scheduling, if this is selected, either “Continuous” or “Motion triggered” or “D/I triggered” could be enabled. For “Continuous”, it means that the IP camera will do the video recording to the NAS device during the whole scheduled period. For “Motion triggered” and/or “D/I triggered”, it means that the IP camera will do the video recording to the NAS device for 30 seconds during the scheduled period each time when the video motion is detected and/or digital input alarm is detected.
4. For the scheduling period, can choose between “Every week”, “Every day” or “Fixed time” :
 - A. For “Every week”, can choose week days of the week and set the time duration of each day.
 - B. For “Every day”, can set the time duration of every day for the scheduling.
 - C. For “Fixed time”, can set the starting date/time and the end date/time of the scheduling period.

SprintSc - Outdoor, Day&night IP Camera

Seeing the video from anywhere

Outdoor IP Camera

Information

Network

Video

Schedule

- Email/ftp Alarm
- NAS Settings
- Scheduling

Admin

Language: English

Schedule Management

Email/ftp Alarm Motion triggered D/I triggered

NAS Record Continuous Motion triggered D/I triggered

Every week Sun Mon Tue Wed Thu Fri Sat

Every day During time 00 : 00 ~ 00 : 00

Fixed time Start time : 2009 / 02 / 05 16 : 00

End time : 2009 / 02 / 05 16 : 00

Add Schedule

Figure 3-14: Schedule management page

3.11. Date/Time

The IP CAM can synchronize the date/time with the universally available time server(for example stdtime.gov.tw) through NTP protocol. The date/time will then be corrected with the time server anytime when the Internet is connected.

Users can choose the different TimeZone of their areas to display the correct time. For some TimeZone areas, the “Daylight Saving Time” could be enabled or disabled. When the “Daylight Saving Time” is enabled, the start and stop time of the Daylight Saving Time could be edited.



Figure 3-15: System date/time settings page

3.12. Admin

In this page, you can modify the web login account. With this account, you can login to the IP CAM and do any modifications. The default account is “admin” without password. If the login account is forgotten, you can reset the IP CAM to the factory default settings by following the steps in section 3.16 and login with the “admin” account.

Please be noticed that this account is different from the video play password in the “Video settings” page.

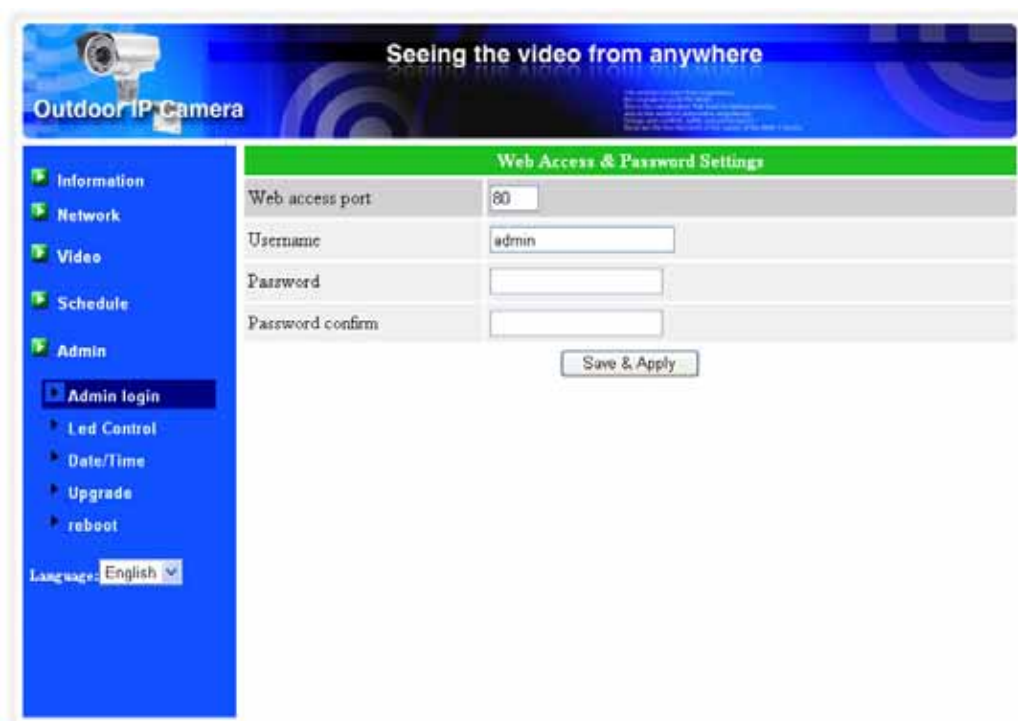

Figure 3-16: Admin settings page

3.13. Upgrade

If there is some new firmware available from the supplier of this IP CAM, you can upgrade the firmware on this page. Please ask for the correct information about FTP server, username/password account and firmware filename from your supplier, and then do this upgrade. A status message about the percentage done in the upgrade procedure is displayed. Please be noticed that during the upgrade procedure, do not power off the IP CAM, otherwise, the IP CAM could probably enter into the safe mode(section 3.14). After the upgrade procedure is finished, the system will restart automatically.

You can upgrade from the ftp server or from the local file in your computer.

During this upgrade procedure, do not try to modify other settings or view the video.



Figure 3-17: Firmware upgrade settings page

SprintSc - Outdoor, Day&night IP Camera



Figure 3-18: Firmware upgrade status page

3.14. Reboot

You can restart the IP CAM manually on this page. All the connected video viewing users will be disconnected.

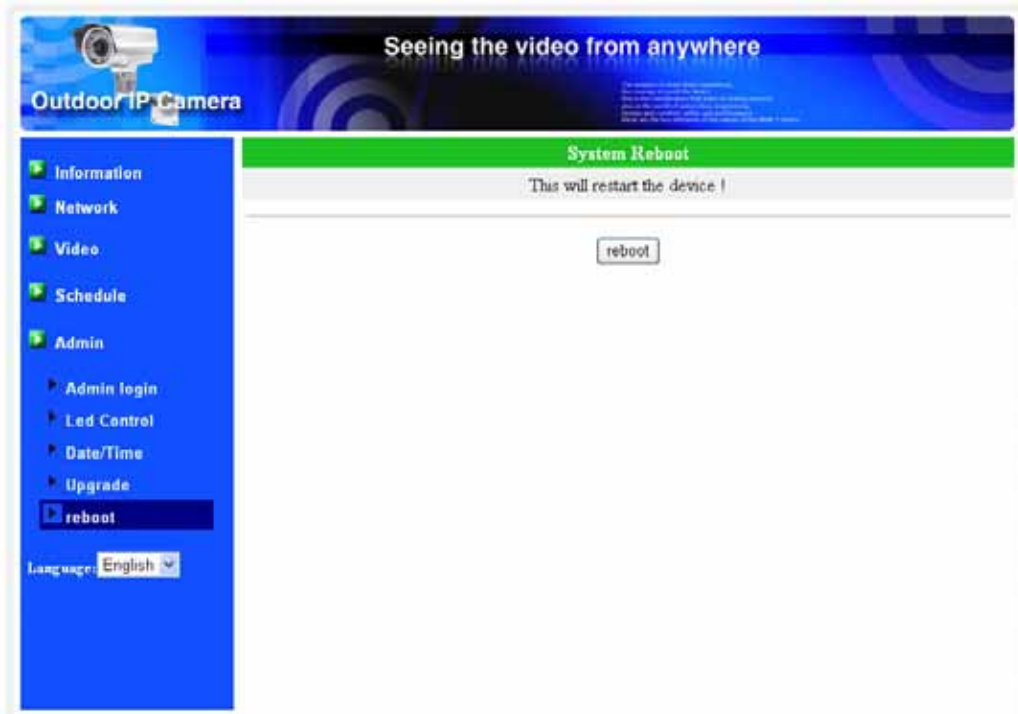

Figure 3-19: System reboot settings page



Figure 3-20: System reboot under-going page

3.15. Safe Mode

If by some abnormal operation, for example, powered off during the critical point of the upgrade procedure, the IP CAM will enter into the safe mode. In this mode, you will see the following “Safe mode” page when login into this IP CAM. Please do the upgrade operation immediately to recover the system. On this safe mode, the IP CAM can not display the video on the CamView software, but you can still find this IP CAM on the “Auto search” list.

The steps to recover from “safe mode” are the followings :

1. Use CamView to locate the IP CAM by clicking the “Auto Search” item on the CamView software.
2. Login into the web configuration page of the IP CAM.
3. Upgrade the firmware from the “Upgrade” page.



Figure 3-21: Safe mode information page

3.16. Set to factory default

For some reason, for example you forgot the web login password, you may want to set the IP CAM to the factory default settings. The only thing you need to do is pressing the “reset” button on the cable for more than **4 seconds** and release it, do this when the IP CAM is powered on. The IP CAM will reset to the factory default settings and restart automatically.

The web login account will be “admin” (no password), the play-video password will be “ipcam” after reset to factory default.

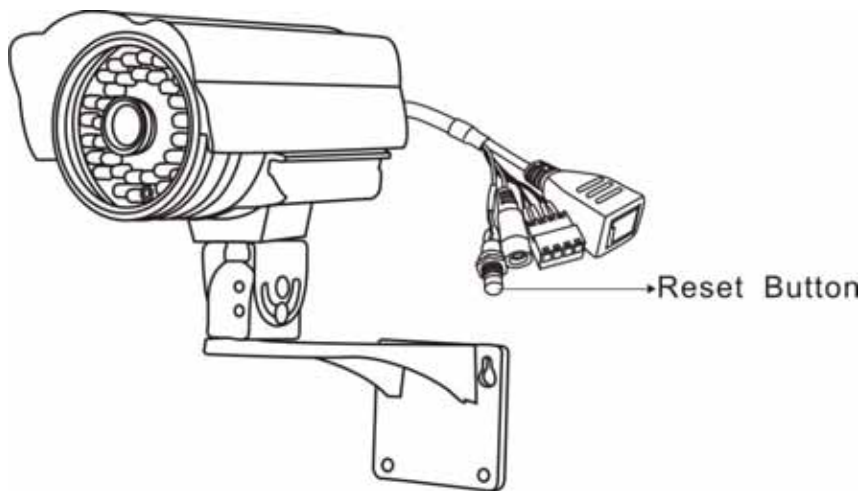

Figure 3-22: Press the reset button to set to the factory default

4. Features and specifications

4.1. Features

- Easily access the camera from anywhere in the world via the ID/password
- No complicated NAT/router settings needed.
- Free video management software - CamView program accompanied for easy access and multi-camera management.
- 3GPP/ISMA support.
- Dual video streaming with separate frame rate/resolution/bandwidth settings for PC and mobile.
- IR led control – support automatic, manual and scheduled modes. But only can see black & white video when IR led is on.
- Built-in Web server for managing via standard web browser.
- Supports enhanced MPEG-4 compression
- Supports resolution of up to 640x480 pixels, 30 frames per second.
- View video from your Wireless or wired Ethernet network
- Supports PPPoE protocol for direct ADSL connection.
- Motion Detection and E-mail/FTP notification, attach jpeg image file.
- Synchronize the time through NTP protocol.
- Connect up to 20 users simultaneously (please see appendix B).
- Event scheduling.
- NAS storage access.
- Online Firmware upgrade, will enter safe mode when power is off during critical firmware upgrade point.
- Watchdog function to prevent system failure.

4.2. Specifications

Models	Outdoor Day&Night IP Camera
Power	DC 12V, 1A
Processors	RISC CPU, hardware video processing and compression.
Network interface	Ethernet 10BaseT/100BaseTX, Auto-MDIX, RJ-45
Image sensor	RGB VGA 1/4 inch CMOS Automatic exposure control, automatic white balance, automatic gain control, automatic brightness control.
Light sensitivity	0.2 Lux (IR led off) 0 Lux (with 30 meters IR leds on) Automatically turn on the IR led in low light environment.
Lens	4.5 mm, F1.9, viewing angle: 55.6°, fixed iris. focus range: 30 cm to infinity Day & night IR lens Motor controlled IR-cut filter (ICR).
Water resistant	IP66 grade water resistant
IR LEDs	36 IR LEDs for up to 30 m distance night illumination.
Buttons	One reset button, to factory default settings
Video compression	MPEG-4 Part 2 (ISO/IEC 14496-2) with motion detection, profiles: Simple Profile, level 0-3
Resolutions	160x120, 320x240, 640x480
Frame rate	Up to 30 fps in all resolutions
Video streaming	MPEG-4 Separate frame rate/resolution/bandwidth settings for PC and mobile.
Image settings	Resolution: VGA(640x480), QVGA(320x240), QQVGA(160x120) Bandwidth : 64k, 128k, 256k, 512k, 768k, 1M, 1.2M, 1.5M bps Frame rate : 1~5, 10, 15, 20, 25, 30 fps
Security	Web management username/password protection Video display ID/password protection
Installation, management and maintenance	Installation tool on CD and Web-based configuration Automatic configuration backup and restore Video management software-CamView for video access and

SprintSc - Outdoor, Day&night IP Camera

	multi-camera management Firmware upgrades via FTP
Minimum Web browsing and management software requirements	Built-in web server for standard web browser access Pentium 4 CPU 1.0 GHz or higher, or equivalent AMD 1GB RAM
Supported protocols	IPv4, HTTP, TCP, ICMP, RTSP, RTP, UDP, IGMP, RTCP, SMTP, SNTP, FTP, DHCP, UPnP, ARP, DNS, PPPoE, etc.
Accessories (included)	Power adaptor, camera bracket, RJ45 ethernet cable, quick installation guide, CD with installation tool/software and User's Manual, ID/Password card.
Video management software	Surveillance application for viewing and archiving up to 16 cameras
Users	Up to 20 simultaneous unicast users (please see appendix B) Unlimited users using multicast
Alarm and event management	Events triggered by video motion detection Notification/upload of JPEG images over FTP and/or email
Dimensions (HxWxD) and weight	130 x 77 x 78 mm, 498 g, exclude camera bracket, exclude power adaptor
Approvals	CE, FCC Part 15 Subpart B Class B Wireless RF - CE, FCC Part 15 Subpart C Power supply: FCC, UL EN 60950
Operating conditions	-20-60 °C Humidity 20 - 80% RH (non-condensing)

5. Package contents



Figure 5-1: IP Cam body



Figure 5-2: Power Adaptor



Figure 5-3: Bracket



Figure 5-4: Ethernet cable



Figure 5-5: Quick installation guide



Figure 5-6: ID/Password Card



Figure 5-7: Installation CD

Appendix A. List of Tested NAT/router Devices

The followings are the list of tested NAT/router devices that can work with the IP CAM and CamView software when viewing in a remote location. You do not need to do any modification on the default settings of the NAT/routers. In some office environment, if some strict firewall function is enabled, it's possible that you can not view the IP CAM video through the firewall router. In this situation, please contact your MIS person to solve the problem.

Brand name	Model name
Asus	WL-550gE
Belkin	P5D7230-4
Buffalo	WHR-G54S
Buffalo	WHR-HP-G54
Corega	CG-WLBARGO
D-Link	DI-524
LanTech	WL54G-BR
Linksys	WRT54G
Netgear	WNR834B
PCi	BLW-HPMM
SMC	SMCWBR14-G2
ZyXEL	P-334WH

Table A-1: List of tested Wireless AP/router devices

Brand name	Model name
AboCom	CAS5047
ASUS	RX3041
Buffalo	BBR-4HG
Corega	CG-BARSD
DLink	DI-604
Edimax	BR-6104K
LanTech	HR-114Pro
Lemel	LM-IS6500
PCi	BRL-04R
ZyXEL	Prestige-334

Table A-2: List of tested Wired NAT/router devices

Appendix B. Maximum Allowed Video Users

The maximum allowed video users for a single IP Cam at the same time is dependent on the video settings including “Internet speed” and resolution. The followings are the summary of the maximum allowed video users:

Notice : when the IP camera is doing NAS recording, this is counted as one video user.

For video resolution of 160x120 pixels

Frame rate\bandwidth	64k ~ 512k	1M ~ 1.5M
5fps ~ 30 fps	20	4

For video resolution of 320x240 pixels

Frame rate\bandwidth	64k ~ 256k	512k	768k	1M ~ 1.5M
5fps ~ 30 fps	20	18	9	4

For video resolution of 640x480 pixels

Frame rate\bandwidth	512k	768k	1M ~ 1.5M
5fps ~ 30 fps	8	6	4

Appendix C. Performance Information

1. Video Performance Information

The video quality is dependent on the video parameter settings and the network quality. If you want to have a better video quality, you will usually set higher resolution and higher frame rate. This is fine when you are viewing the video locally in the same network. But when you want to see the video remotely through the Internet, you need to know the Internet speed (bandwidth) connected to your home network. If the “Internet speed” setting of your IP camera is very large, but your real Internet speed (bandwidth) is relatively low, the video quality could be very bad. In some worst case, the video display could be disconnected. In order to have the best video quality, you better have broadband service from your ISP and set the “Internet speed” of the IP camera a little lower than the real Internet speed provided by your ISP.

Also need to notice that when multiple users are displaying the videos from the same IP camera at the same time, the video bandwidth times number of users will be needed for the Internet speed.

Appendix D. Trouble shooting

1. Could I adjust the effective focus of the IP Cam?

A: The effective focus of the IP Cam is from 30cm to infinity, so, in almost all circumstances you can see the video clearly. There is no need to adjust the effective focus.

2. What's the viewing angle of the IP Cam?

A: The viewing angle of the IP Cam is about 60 degrees.

3. What's the longest distance using the IP Cam to see the video?

A: When using the IP Cam to see a long-distance object, whether it's clear or not depends on the size of the object. Usually when your eyes can see something clearly in that distance, the IP Cam can also see that object clearly in about the same distance.

4. What should I do if the password is forgotten, and the ID/password card is missing?

A: The easiest way to solve this problem is to reset the IP Cam to the factory default. Please press the reset button on the cable of the IP Cam for more than 4 seconds and release it. The IP Cam will then restart to the factory default. The default administrator account is "admin", administrator password is empty. The default video-play password is "ipcam". You can adjust these account and passwords by using the browser to login into the IP Cam and do the needed modifications.

5. I can see the video in a remote place, but the video quality is not good and sometimes the video will disconnect and then the video will reconnect again by itself.

A: It's probably because the internet bandwidth (internet speed) is not big enough. Please try to apply for a better internet connection from your Internet Service Provider or decrease the bandwidth settings of the IP Cam. You can adjust the bandwidth requirement of the IP Cam either from the CamView software or login into the web configuration page of the IP Cam to do the modification.

6. Does the IP Cam provide the recording function?

A: You can do the recording of the video/audio of the IP Cam from the CamView software with the CamView software. You can also do the video/audio recording to the standard NAS storage device. Another software CamPlay is needed to playback the recorded vide/audio files.

7. Can I connect the IP camera directly to my PC/notebook with an Ethernet cable?

A: If the IP camera is directly connected to your PC/notebook computer using an Ethernet cable, the IP camera will automatically use an IP address called "auto IP" with IP address 169.254.xxx.xxx. If your PC/notebook computer is configured to DHCP, it will also use an "auto IP" address. But this will take about one minute after the IP camera is connected to the computer and you need to make sure that the WiFi interface on your PC/notebook computer is disabled. After about one minute, you can run the CamView software to access the IP camera, the CAM ID should be displayed on the "auto-search" list. You can then see the video by double clicking the CAM ID icon. But you need to know that in this situation, other local or remote computer can not see the video.

Appendix E. 3GPP/ISMA operation

3GPP/ISMA is using RTSP protocol for 3G mobile phone to display the video stream from some network devices, including IP camera. The SSC713w support the RTSP protocol and video codec needed by 3GPP/ISMA. Users only need to access the address rtsp://ip_cam_address/CAM_ID.password on the 3G mobile phone to access the video of the IP camera. No other extra configuration is needed on the IP camera. Where ip_cam_address is the public IP address of the IP camera. CAM_ID is the unique Camera ID of the specific IP camera. Password is the video play password of the specific IP camera(detailed in section 3.6). Different 3G mobile phone may need different operation to be able to key in the rtsp address, please contact the 3G mobile phone customer service for more details.

The video quality and resolution is the same value as set on the “video settings” page. Since the bandwidth provided by the 3G service is under 256k bps, better to configure the “Internet speed” of the IP camera to 128k or 64k bps.

For more information about operation on different 3G mobile phones, please contact us for detailed document.

Appendix F. Third party and embedded web page

integration

For third party and embedded web page integration, IP Cam support the standard RTSP protocol and video codecs needed by most generally used video play software, including Apple QuickTime and VideoLAN. The supported media protocols including TCP and UDP. IP Cam will automatically use TCP or UDP media stream depends on the connection request. The video codec supported is MPEG4.

The access methods are the followings :

rtsp://ip_cam_address/CAM_ID.password.mp2 for MPEG4 video + MPEG2 audio
rtsp://ip_cam_address/CAM_ID.password for MPEG4 video + AMR-NB audio

Where ip_cam_address is the IP address of the IP camera. CAM_ID is the unique Camera ID of the specific IP camera. Password is the video play password of the specific IP camera(detailed in section 3.6). Users can modify the password of the IP camera to prevent others to see the video.

For embedded web page integration, add the following codes into the proper position of the desired web page :

```
<object classid="clsid:5C519EC4-2BAE-44CE-B7F5-AD0CCD4BEFBD"  
id="mpeg4ax"  
codebase="http://www.sprintsc.net/ActiveX/axmpeg4.cab#Version=0,0,0,0"  
width="320" height="240">  
<param name="Src" value=" rtsp://ip_cam_address/CAM_ID.password.mp2">  
</object>
```