



This manual contains important warnings and information.
READ AND KEEP FOR REFERENCE.

INSTRUCTIONS

Flex Airless Spray Gun

5000 psi (345 bar) MAXIMUM WORKING PRESSURE

Model 235-457, Series C

Bare gun.

Model 237-691, Series B

Includes RAC® IV DripLess™ Tip Guard, 517 size SwitchTip™, and 2 finger trigger.

Model 235-459, Series D

Includes RAC® IV DripLess™ Tip Guard, 517 size SwitchTip™, and 2 finger trigger.

Model 235-458, Series C

Includes the Standard (non-reversing) DripLess™ Tip Guard. Spray tip not included; order separately.

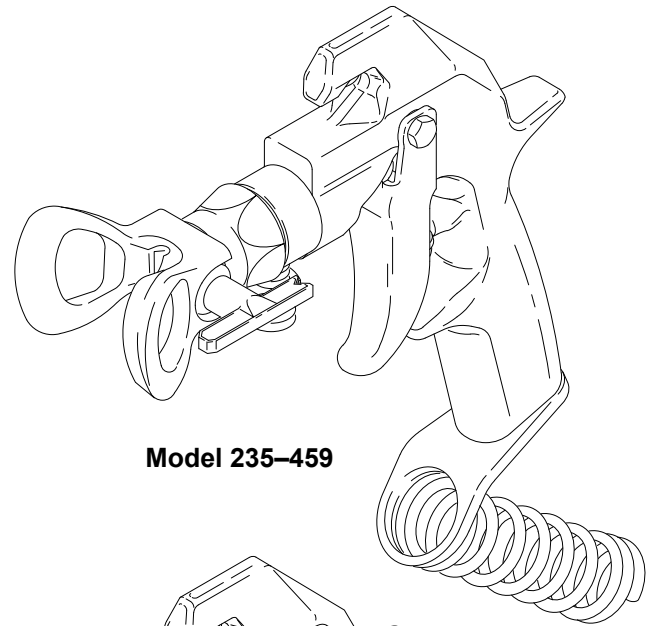

Model 235-459

01460

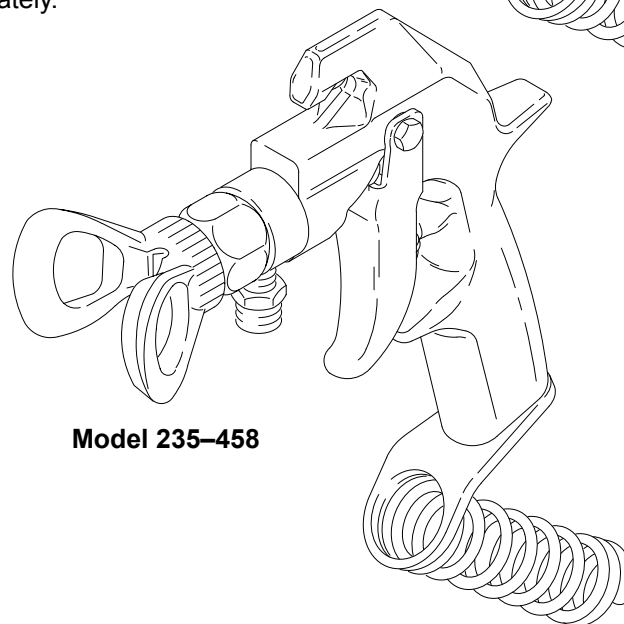

Model 235-458

Patents Pending



Table of Contents

Warnings	2
Installation/Operation	4
Pressure Relief Procedure	5
System Requirements	5
How to Use the Gun Trigger Safety	5
How to Use the Gun	6
How to Adjust the Spray Pattern	6
How to Clean the Spray Tip and Clear a Spray Tip Obstruction	7
How to Check the Gun Diffuser	8
How to Clean the Filter	6
How to Flush the Gun	8
Service	9
Parts Drawing	11
Technical Data	14
Graco Phone Numbers	14
Warranty	16

Symbols

Warning Symbol



This symbol alerts you to the possibility of serious injury or death if you do not follow the instructions.

Caution Symbol



This symbol alerts you to the possibility of damage to or destruction of equipment if you do not follow the instructions.

! WARNING



INSTRUCTIONS

EQUIPMENT MISUSE HAZARD

Equipment misuse can cause the equipment to rupture or malfunction and result in serious injury.

- This equipment is for professional use only.
- Read all instruction manuals, tags, and labels before operating the equipment.
- Use the equipment only for its intended purpose. If you are not sure, call your Graco distributor.
- Do not alter or modify this equipment.
- Check equipment daily. Repair or replace worn or damaged parts immediately.
- Do not exceed the maximum working pressure of the lowest rated system component. Refer to the **Technical Data** on page 14 for the maximum working pressure of this equipment.
- Use fluids and solvents which are compatible with the equipment wetted parts. Refer to the **Technical Data** section of all equipment manuals. Read the fluid and solvent manufacturer's warnings.
- Do not use 1,1,1-trichloroethane, methylene chloride, other halogenated hydrocarbon solvents or fluids containing such solvents in pressurized aluminum equipment. Such use could result in a chemical reaction, with the possibility of explosion.
- Do not use hoses to pull equipment.
- Route hoses away from traffic areas, sharp edges, moving parts, and hot surfaces. Do not expose Graco hoses to temperatures above 66°C (150°F) or below -40°C (-40°F).
- Wear hearing protection when operating this equipment.
- Do not lift pressurized equipment.
- Comply with all applicable local, state, and national fire, electrical, and safety regulations.

! WARNING



INJECTION HAZARD

Spray from the gun, leaks or ruptured components can inject fluid into your body and cause extremely serious injury, including the need for amputation. Fluid splashed in the eyes or on the skin can also cause serious injury.



- Fluid injected into the skin might look like just a cut, but it is a serious injury. **Get immediate medical attention.**
- Do not point the gun at anyone or at any part of the body.
- Do not put your hand or fingers over the spray tip.
- Do not stop or deflect leaks with your hand, body, glove or rag.
- Do not “blow back” fluid; this is not an air spray system.
- Always have the tip guard and the trigger guard on the gun when spraying.
- Check the gun diffuser operation weekly. See page 8.
- Be sure the gun trigger safety operates before spraying.
- Lock the gun trigger safety when you stop spraying.
- Follow the **Pressure Relief Procedure** on page 5 if the spray tip clogs and before cleaning, checking or servicing the equipment.
- Tighten all fluid connections before operating the equipment.
- Check the hoses, tubes, and couplings daily. Replace worn or damaged parts immediately. Do not repair high pressure couplings; you must replace the entire hose.
- Fluid hoses must have spring guards on both ends, to help protect them from rupture caused by kinks or bends near the couplings.



MOVING PARTS HAZARD

Moving parts can pinch or amputate your fingers.

- Keep clear of all moving parts when starting or operating the pump.
- Before servicing the equipment, follow the **Pressure Relief Procedure** on page 5 to prevent the equipment from starting unexpectedly.



RECOIL HAZARD

Due to the high pressure fluid emitted, a strong recoil action may occur when you trigger this gun. If you are unprepared, your hand could be forced back toward your body or you could lose your balance and fall, resulting in serious injury.

WARNING



FIRE AND EXPLOSION HAZARD

Improper grounding, poor ventilation, open flames or sparks can cause a hazardous condition and result in a fire or explosion and serious injury.



- If there is any static sparking or you feel an electric shock while using this equipment, **stop spraying immediately**. Do not use the equipment until you identify and correct the problem.
- Provide fresh air ventilation to avoid the buildup of flammable fumes from solvents or the fluid being sprayed.
- Keep the spray area free of debris, including solvent, rags, and gasoline.
- Electrically disconnect all equipment in the spray area.
- Extinguish all open flames or pilot lights in the spray area.
- Do not smoke in the spray area.
- Do not turn on or off any light switch in the spray area while operating or if fumes are present.
- Do not operate a gasoline engine in the spray area.
- Ground the equipment and the object being sprayed. Refer to your pump instruction manual.



TOXIC FLUID HAZARD

Hazardous fluid or toxic fumes can cause serious injury or death if splashed in the eyes or on the skin, inhaled, or swallowed.

- Know the specific hazards of the fluid you are using.
- Store hazardous fluid in an approved container. Dispose of hazardous fluid according to all local, state and national guidelines.
- Always wear protective eyewear, gloves, clothing and respirator as recommended by the fluid and solvent manufacturer.

Installation/Operation

Pressure Relief Procedure

WARNING



INJECTION HAZARD

The system pressure must be manually relieved to prevent the system from starting or spraying accidentally. Fluid under high pressure can be injected through the skin and cause serious injury. To reduce the risk of an injury from injection, splashing fluid, or moving parts, follow the **Pressure Relief Procedure** whenever you:

- are instructed to relieve the pressure,
- stop spraying,
- check or service any of the system equipment,
- or install or clean the spray tips.

1. Lock the gun trigger safety.
2. Shut off the power supply to the pump. Close any bleed-type master air valves.
3. Unlock the gun trigger safety.
4. Hold a metal part of the gun firmly to the side of a grounded metal pail, and trigger the gun to relieve pressure.
5. Lock the gun trigger safety.
6. Open the drain valve (required in your system), having a container ready to catch the drainage.
7. Leave the drain valve open until you are ready to spray again.

If you suspect that the spray tip or hose is completely clogged, or that pressure has not been fully relieved after following the steps above, very slowly loosen the tip guard retaining nut or hose end coupling and relieve pressure gradually, then loosen completely. Now clear the tip or hose.

System Requirements

WARNING

Keep the wallet-sized warning card provided with this gun with the operator at all times. The card contains important treatment information should an injection injury occur. Additional cards are available at no charge from Graco Inc.

WARNING

Be sure your system has a bleed-type master air valve (pneumatic pumps only) and a pressure drain valve. These accessories help reduce the risk of serious bodily injury, including fluid injection, splashing in the eyes or on the skin, or injury from moving parts, if you are adjusting or repairing the pump or gun.

1. The bleed-type master air valve (air-powered pumps only) relieves air trapped between this valve and the pump after the air regulator is shut off. Trapped air can cause the pump to cycle unexpectedly.
2. The pressure drain valve assists in relieving fluid pressure in the displacement pump, hose and gun: triggering the gun to relieve pressure may not be sufficient.
3. Strain the fluid you are spraying if it contains particles which could clog the spray tip.

How to Use the Gun Trigger Safety

1. To lock the gun trigger safety, turn the latch (A) to a right angle with the gun body. See Fig. 1.
2. To unlock the gun trigger safety, push the latch (A) out and turn it parallel with the gun body.

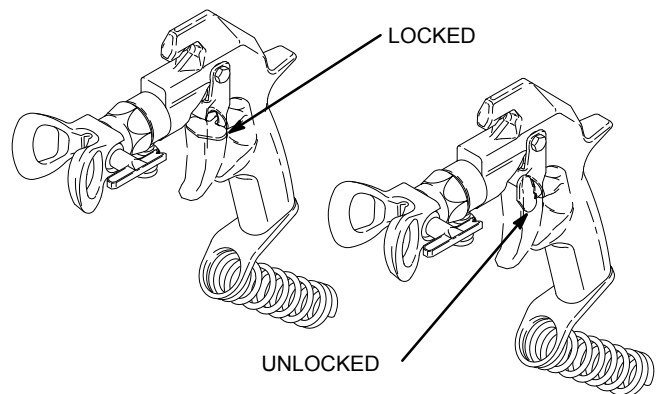

Fig. 1

01464

Installation/Operation

How to Use the Gun

1. Guide a grounded fluid hose (with spring guard) through the hose guard (14) and connect the hose to the gun inlet. See Fig. 2.
2. With no tip installed, start the pump. Flush the pump according to the instructions supplied with it. Prime the system with the fluid.

⚠ WARNING

To reduce the risk of serious injury whenever you are instructed to relieve pressure, always follow the **Pressure Relief Procedure** on page 5.

3. **Relieve the pressure.** Be sure the gun trigger safety is locked. See Fig. 1.
 4. Model 235–459: Unscrew the tip guard (1) and install the tip (A) and the gasket (2d) in the nut of the tip guard. Screw the assembly firmly onto the gun. Tighten the assembly with a wrench. See Fig. 2.
- NOTE:** If the gasket (2d) is not installed, the gun will leak.
5. Models 235–459 and 237–691: install the SwitchTip (19) and the tip guard (18). See manual 308–644, supplied.

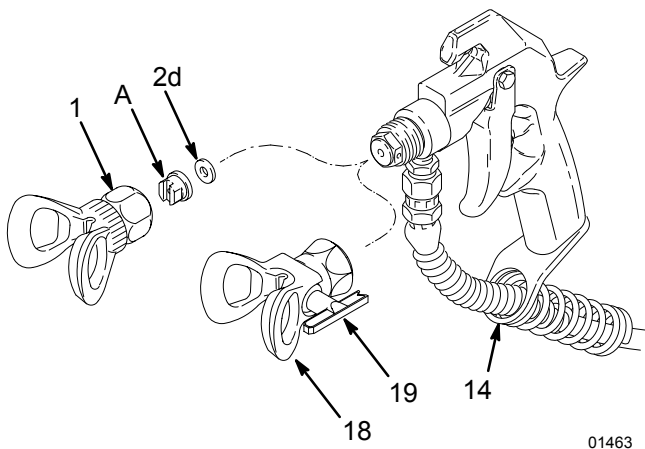

Fig. 2

6. Start the pump. Adjust the fluid pressure until the spray is completely atomized. Use the lowest pressure necessary to get the desired results. Higher pressure may not improve the spray pattern and will cause premature tip wear and pump wear.

7. If adjusting the pressure does not give a good spray pattern, follow the **Pressure Relief Procedure** on page 5 and then try another tip size.
8. Use a full-open, full-close triggering action. Hold the gun about 14 in. (350 mm) from and at right angles to the work surface. Don't swing the gun in an arc. Practice to find the best length and speed of stroke.

How to Adjust the Spray Pattern.

1. To adjust the spray pattern direction, follow the **Pressure Relief Procedure** on page 5. Loosen the tip guard retaining nut (B). Turn the tip guard/ tip groove horizontally (C) for a horizontal pattern and vertically (A) for a vertical pattern. Tighten the retaining nut.
2. The spray tip orifice and spray angle determines the coverage and size of the pattern. When more coverage is needed, use a larger spray tip rather than increasing the fluid pressure.

⚠ CAUTION

The openings in the tip guard reduce paint buildup on the tip guard while spraying. Any damage to the sharp edges of the openings causes paint to collect at that area. Never hang the gun by the tip guard.

KEY

- A Tip guard shown in position for vertical spray pattern
- B Retaining nut
- C Tip guard shown in position for horizontal spray pattern

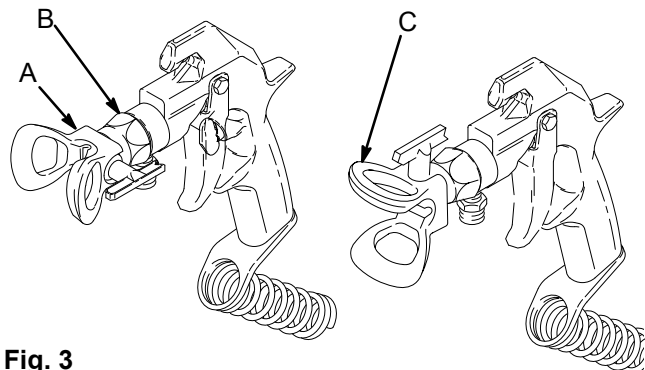

Fig. 3

Installation/Operation

How to Clean the Spray Tip and Clear a Spray Tip Obstruction.

⚠ WARNING

To reduce the risk of fluid injection or splashing in the eyes or on the skin, **do not** hold a hand, body or rag in front of the spray tip when cleaning or checking a clogged tip. Point the gun toward the ground or into a waste container when checking to see if the spray tip is cleared.

Do not try to “blow back” paint; this is **not** an air spray gun.

Do not wipe fluid buildup off the gun or spray tip until pressure is relieved.

Cleaning during the day.

1. Follow the **Pressure Relief Procedure**, page 5.
2. Clean the front of the tip frequently during the day to help reduce buildup. Also clean the tip and tip guard at the end of each work day. Use a solvent-soaked brush to clean the spray tip.

Clearing an obstruction.

If the spray tip clogs while spraying, immediately stop spraying, then:

Gun 235–458 – with standard tip guard

1. Engage the trigger safety latch, open the pressure drain valve.

2. Remove the spray tip and blow out the obstruction by applying air to the front of the spray tip. Or, let the spray tip and gun nozzle soak to dissolve the obstruction. If it won't dissolve, jar it out by tapping the back of the spray tip against a flat surface.

⚠ CAUTION

Never soak the entire gun in solvent. Prolonged exposure to solvent can ruin the packings.

Gun 235–459 and 237–691– with RAC IV tip guard

1. Engage the trigger safety latch. Rotate the RAC IV tip handle 180°. See Fig. 4.
2. Disengage the trigger safety latch. Trigger the gun into a pail or onto the ground to remove clog.
3. Engage the trigger safety latch. Rotate the tip handle to the spraying position.
4. If the tip is still clogged, lock the gun trigger safety, shut off the sprayer and disconnect the power source, and open the pressure drain valve to relieve pressure. Clean the spray tip as shown in manual 308–644, supplied with the RAC IV.

KEY

- A Handle shown in spraying position. Turn handle 180° and trigger gun to clear clog.

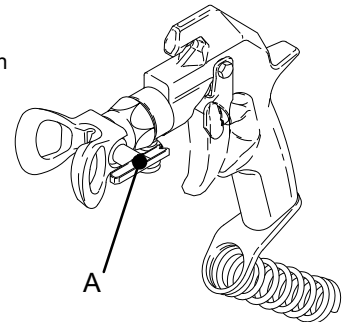

Fig. 4

Installation/Operation

How to Check the Gun Diffuser Operation

Check the diffuser operation weekly. The gun diffuser/seat (2a) breaks up spray and reduces the risk of fluid injection when the tip is not installed. Perform the test below. If it fails, replace the entire Needle Kit, Part No. 235–474, as instructed on page 7. Diffuser/seats are not sold separately since the gun will leak if an old needle is used with a new diffuser/seat.

WARNING

To reduce the risk of serious injury whenever you are instructed to relieve pressure, always follow the **Pressure Relief Procedure** on page 5.

1. Follow the **Pressure Relief Procedure**, page 5.
2. Remove the tip guard and spray tip.
3. Start the sprayer and adjust it to the lowest pressure.
4. Aim the gun into a grounded metal pail while holding it firmly to the pail. Trigger the gun. If the fluid emitted *is not* diffused into an irregular stream, replace the entire needle kit immediately. See Fig. 5.

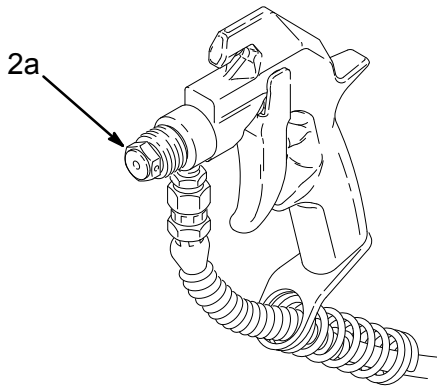

Fig. 5

How to Flush the Gun.

Always flush the pump and the gun before the fluid being sprayed can dry in it.

NOTE: If it is available, the flushing procedure provided in your pump or sprayer manual should be used instead of this procedure.

WARNING



FIRE AND EXPLOSION HAZARD

Static sparking and splashing may cause fire, explosion and serious injury. To reduce static sparking and splashing, always remove the spray tip from the gun, and hold a metal part of the gun firmly to the side of a grounded metal pail when flushing.

WARNING

To reduce the risk of serious injury whenever you are instructed to relieve pressure, always follow the **Pressure Relief Procedure** on page 5.

1. Follow the **Pressure Relief Procedure**, page 5.
2. Remove the tip guard and spray tip. Soak and clean the parts.
3. Put the pump intake in a grounded pail of water or solvent.
4. Start the pump at its lowest pressure.
5. Trigger the gun into the original pail. When solvent appears, release the trigger.
6. Now trigger the gun into the solvent pail. Circulate the fluid until the system is thoroughly flushed.
7. Follow the **Pressure Relief Procedure**, page 5.

Service

⚠ CAUTION

Do not attempt to install an old style needle in this gun. The front of the new needle is marked with a + below the Graco symbol.

Notes:

Use Needle Kit 235–474.

Use all the new parts for the best results. Parts included in the kit are shown with one asterisk, (2a*).

Keep parts very clean. Dried paint or other contaminants cause friction which causes parts to wear faster.

Needle Replacement.

⚠ WARNING

To reduce the risk of serious injury whenever you are instructed to relieve pressure, always follow the **Pressure Relief Procedure** on page 5.

1. Follow the **Pressure Relief Procedure**, page 5.
2. Remove the hose, tip guard, spray tip and gasket.
3. Remove the diffuser/seat (2a*) and gasket (2b*). Remove the screw (12), pivot pin (11), and trigger (8). See Fig. 6.

⚠ Lubricate, then torque to 20–25 ft-lb (27–34 N.m)

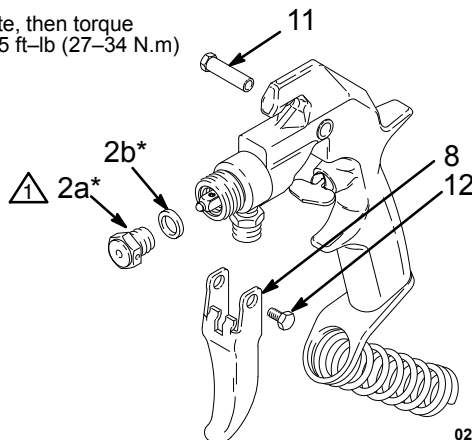

Fig. 6

02349

4. Insert a punch into the rear of the gun and tap it to push the needle (2c*) out the front of the gun. See Fig. 7.

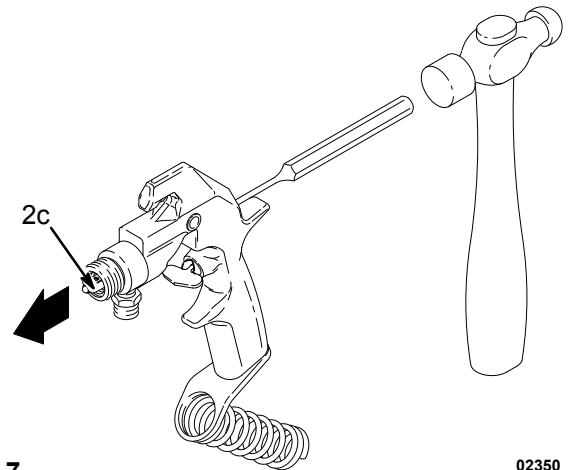

Fig. 7

02350

5. Clean the internal passages of the gun.
6. Grease the rings (A) of the new needle (2c*). See Fig. 8.

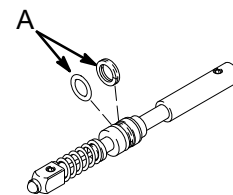

Fig. 8

Service

- Slide the rear of the needle (2c*) into the front of the gun. Slide the tool (B), provided with the repair kit, into the gun, around the needle. Lightly tap the tool with a hammer or lightly press the tool against a flat surface to seat the needle. See Fig. 9. Remove the tool.

⚠ CAUTION

Tapping or pressing the tool too hard may jam the tool and damage the needle.

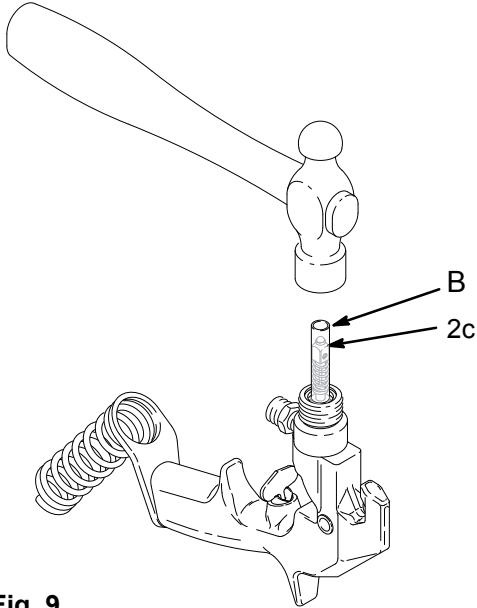

Fig. 9

02351

- Grease the end of the needle.
- Grease the diffuser/seat threads. Place the new gasket (2b*) on the diffuser/seat (2a*) and screw the assembly into the fluid housing (7). Torque to 20–25 ft-lb (27–34 N.m). See Fig. 6.
- Install the trigger (8), pivot pin (11) and screw (12). See Fig. 6.

NOTE: No needle or trigger adjustment is needed.

Parts

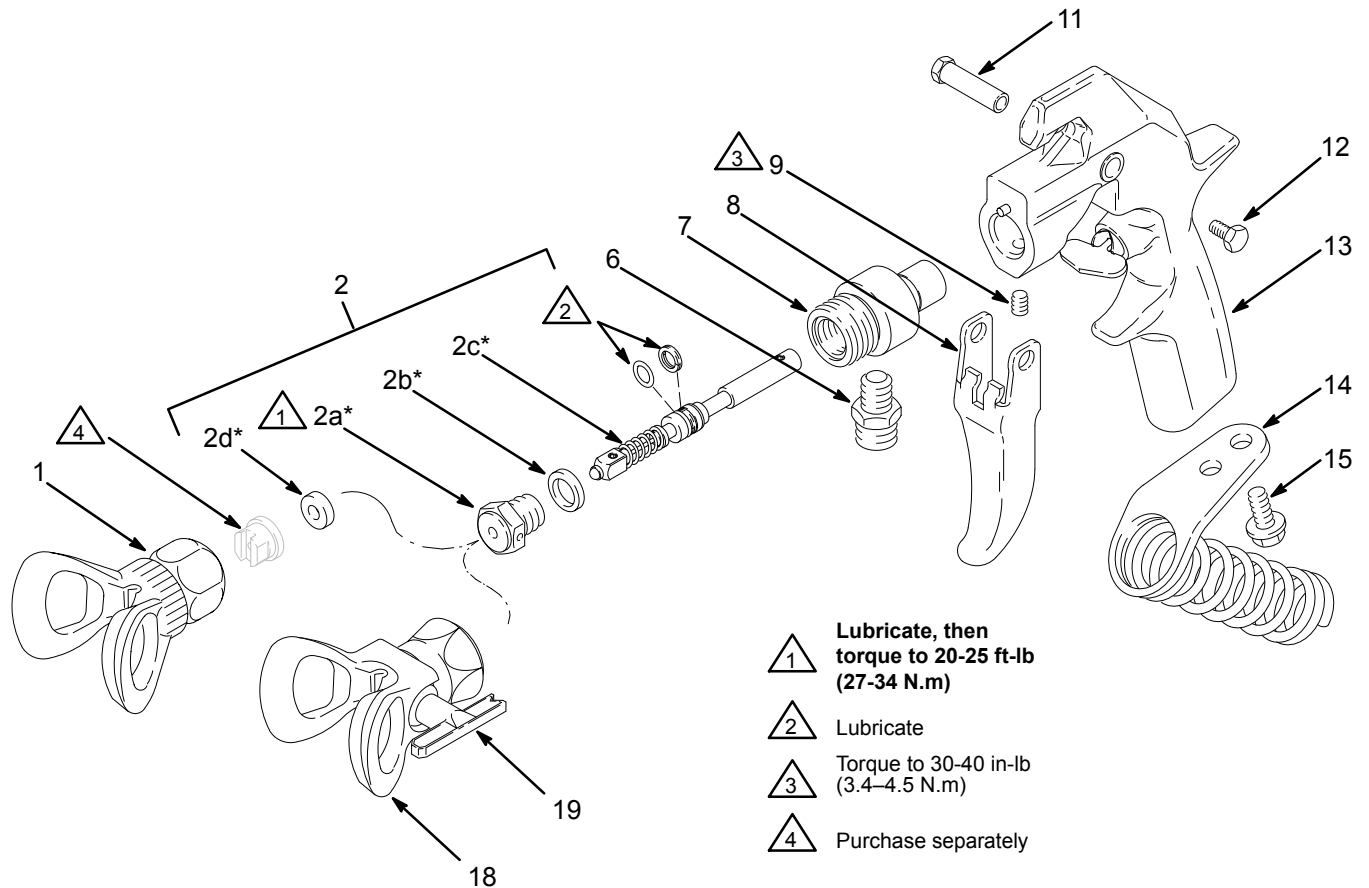

- Lubricate, then torque to 20-25 ft-lb (27-34 N.m)
- Lubricate
- Torque to 30-40 in-lb (3.4-4.5 N.m)
- Purchase separately

01468

Model 235-459, Series D
Model 237-691, Series B
 Includes RAC® IV DripLess™ Tip Guard.
 Includes items 2 to 19 as indicated by model number.

Model 235-457, Series C
 Includes the Standard (non-reversing) DripLess™ Tip Guard.
 Includes items 2 (not 2d) to 17 as indicated by model number.

Model 235-458, Series C
 Includes the Standard (non-reversing) DripLess™ Tip Guard.
 Includes items 1 to 17 as indicated by model number.

Ref No.	Part No.	Description	Qty.
1	220-222	STANDARD TIP GUARD <i>Model 235-458 only</i>	1
2	235-474	NEEDLE KIT <i>Includes items 2a to 2d</i>	1
2a*	◇	DIFFUSER/SEAT	1
2b*	◇	GASKET, copper	1
2c*	◇	NEEDLE	1
2d*	166-969	TIP GASKET <i>Use in gun model 235-458 only</i>	1

Ref No.	Part No.	Description	Qty.
6	169-797	ADAPTER	1
7	187-972	FLUID HOUSING	1
8	187-985	TRIGGER	1
9	102-207	SETSCREW, 1/4-20	1
11	187-965	PIVOT PIN	1
12	203-953	SCREW, hex washer hd, 10-24	1
13	235-470	GUN HANDLE	1
14	218-139	HOSE HOLDER	1
15	107-257	CAPSCREW, 1/4-20 x 1/2"	1
16▲	187-987	WARNING TAG <i>not shown</i> <i>Model 235-458 only</i>	1
	▲ 187-346	WARNING SHEET <i>not shown</i> <i>Model 235-459 only</i>	1
17▲	222-385	WARNING CARD <i>not shown</i>	1
18	220-422	RAC IV DripLess TIP GUARD <i>Model 235-459 only</i>	1
19	221-517	SwitchTip, Size 517 <i>Model 235-459 only</i>	1

* These parts are also included in Repair Kit 235-474, which may be purchased separately. Kit also includes installation tool.

◇ Part not sold separately.

▲ Replacement Danger and Warning labels, tags, and cards are available at no cost.

Accessories

FILTERS

3000 psi (210 bar) Maximum Working Pressure.

Adequate filtering is important for a good surface finish and to minimize tip clogging. These filters provide secondary filtering. Various screen meshes are available.

Mounts in hose

- 213-068** Includes filter body, spring and one 100 mesh screen.
- 213-069** Includes filter spring and one 60 mesh screen.
Use with above filter body.
- 210-742** Includes filter spring and one 100 mesh screen.
Use with above filter body.
- 210-729** Includes assembly 213-068 plus a 3 ft (0.9 m) whip hose for more flexible gun movement.

Mounts between hose and gun

- 210-500** Includes swivel, adapter and one 60 mesh screen

Replacement screens for above filters

- 210-731** Three 60 mesh (250 micron) screens
- 210-732** Three 100 mesh (149 micron) screens
- 210-733** Three 200 mesh (74 micron) screens

SWIVELS and WHIP HOSES

Swivels and whip hoses provide more flexible gun movement for easier handling and less fatigue. Working pressures are listed in the descriptions.

- 207-946** Swivel, 1/2 npsm x 3/8 npt(f)
5000 psi (350 bar) Max. Working Pressure
- 204-940** Swivel, 1/4 npt x 1/4 npsm
3000 psi (210 bar) Max. Working Pressure
- 214-701** Whip hose, nylon, coupled 1/4 npsm(f) x 3/8 npt(m), spring guards both ends.
3000 psi (210 bar) Max. Working Pressure

TOOLS

NYLON BRUSHES

Use to thoroughly clean the gun's fluid passages.

- 101-891** 0.375" (9 mm) dia.
- 101-892** 0.625" (16 mm) dia.



- WRENCH 171-147**
Fits all hexes on the gun.

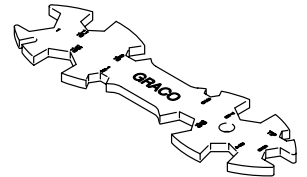

- NEEDLE TOOL 188-369**
Required to install new needle without damaging it.

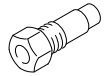

TIP GUARDS

These tip guards fit all Graco airless spray guns. Choose the one that's right for your application. One of these tip guards is included with every Graco airless gun.

- 220-422** RAC® IV DripLess™ Tip Guard. Includes SwitchTip of choice. See your distributor for available sizes.

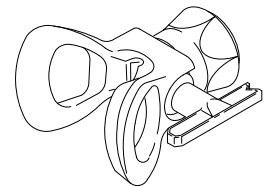

- 220-222** Standard DripLess™ Tip Guard. Order flat tip separately. See your distributor for available sizes.

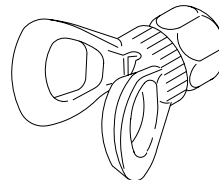

- 222-674** Heavy Duty RAC® DripLess™ Tip Guard. Order SwitchTip separately. See your distributor for available sizes.

Technical Data

Maximum Working Pressure 5000 psi (350 bar)
Fluid Orifice Size 0.090 in. (2.3 mm)
Wetted Parts Stainless steel, Polyethylene,
Polyurethane, Nylon, PTFE

Weight 18 oz. (510 g)
Inlet 1/4 npsm(m)
Maximum material temperature 120°F (50°C)

Sound Data

Sound Pressure Level 78 dB(A)*
Sound Power Level 87 dB(A)*

* Measured while spraying waterbase paint – gravity
1.36 through a 517 tip at 3,000 psi (207 bar).
Per ISO 3744

PTFE® is a registered trademark of the DuPont
Company.

Graco Phone Number

TO PLACE AN ORDER, contact your Graco distributor, or call this number to identify the distributor closest to you: **1-800-328-0211 Toll Free**.

Manual Change Summary

Changed: Model 237–691, Series C
To: Model 237–691, Series B

The Graco Warranty and Disclaimers

WARRANTY

Graco warrants all equipment manufactured by it and bearing its name to be free from defects in material and workmanship on the date of sale by an authorized Graco distributor to the original purchaser for use. As purchaser's sole remedy for breach of this warranty, Graco will, for a period of twelve months from the date of sale, repair or replace any part of the equipment proven defective. This warranty applies only when the equipment is installed, operated and maintained in accordance with Graco's written recommendations.

This warranty does not cover, and Graco shall not be liable for, any malfunction, damage or wear caused by faulty installation, misapplication, abrasion, corrosion, inadequate or improper maintenance, negligence, accident, tampering, or substitution of non-Graco component parts. Nor shall Graco be liable for malfunction, damage or wear caused by the incompatibility with Graco equipment of structures, accessories, equipment or materials not supplied by Graco, or the improper design, manufacture, installation, operation or maintenance of structures, accessories, equipment or materials not supplied by Graco.

This warranty is conditioned upon the prepaid return of the equipment claimed to be defective to an authorized Graco distributor for verification of the claim. If the claimed defect is verified, Graco will repair or replace free of charge any defective parts. The equipment will be returned to the original purchaser transportation prepaid. If inspection of the equipment does not disclose any defect in material or workmanship, repairs will be made at a reasonable charge, which charges may include the costs of parts, labor and transportation.

DISCLAIMERS AND LIMITATIONS

The terms of this warranty constitute purchaser's sole and exclusive remedy and are in lieu of any other warranties (express or implied), **including warranty of merchantability or warranty of fitness for a particular purpose**, and of any non-contractual liabilities, including product liabilities, based on negligence or strict liability. Every form of liability for direct, special or consequential damages or loss is expressly excluded and denied. In no case shall Graco's liability exceed the amount of the purchase price. Any action for breach of warranty must be brought within two (2) years of the date of sale.

EQUIPMENT NOT COVERED BY GRACO WARRANTY

Graco makes no warranty, and disclaims all implied **warranties of merchantability and fitness for a particular purpose**, with respect to accessories, equipment, materials, or components sold but not manufactured by Graco. These items sold, but not manufactured by Graco (such as electric motor, switches, hose, etc.) are subject to the warranty, if any, of their manufacturer. Graco will provide purchaser with reasonable assistance in making any claim for breach of these warranties.

*All written and visual data contained in this document reflects the latest product information available at the time of publication.
Graco reserves the right to make changes at any time without notice.*

Sales Offices: Atlanta, Chicago, Detroit, Los Angeles
Foreign Offices: Belgium, Canada, England, Korea, Switzerland, France, Germany, Hong Kong, Japan

GRACO INC. P.O. BOX 1441 MINNEAPOLIS, MN 55440-1441

PRINTED IN U.S.A. 308-235 December 1992, Revised February 1998