



Compact universal controllers

RWF50...

The RWF50 is used mainly for controlling the temperature or pressure in oil- or gas-fired heating plants.

If the relevant parameters are set, the RWF50 can be switched to cooling mode and then controls in reverse operation.

The RWF50 and this Data Sheet are intended for use by OEMs which integrate the controllers in their products!

Use

The RWF50 is used either as a 3-position controller without angular positioning feedback or a continuous controller with analog output depending on the version. An external switch can be used to change to a 2-position controller for controlling 2-stage burners. The integrated thermostat function switches the burner on and off.

LED symbols on the front indicate the following operating states:

- Burner release
- Control pulses OPEN or CLOSED for driving the burner's air damper when using a modulating burner control, or stage I / stage II when using 2-stage burner control
- 2-stage operation

During operation, the digital displays above the keys shows the setpoint (green), the actual value (red) and – when making parameter settings – the relevant parameters.

Supplementary documentation

User Manual RWF50	U7866
Environmental Declaration RWF50.....	E7866

Warning notes



To avoid injury to persons, damage to property or the environment, the following warning notes must be observed!

Do not open, interfere with or modify the unit!

- All activities (mounting, installation and service work, etc.) must be performed by qualified staff
- Before making any wiring changes in the connection area, completely isolate the plant from mains supply (all-polar disconnection). Ensure that the plant cannot be inadvertently switched on again and that it is indeed dead. If not observed, there is a risk of electric shock hazard
- Ensure protection against electric shock hazard by providing adequate protection for the connection terminals
- When selecting the cable material, during installation and when creating the electrical connections, observe the regulations of VDE 0100 *Erection of power installations with rated voltages below AC 1000 V* and the relevant national regulations
- Disconnect the device from the mains supply if there is a risk of touching live parts while work is carried out
- Each time work has been carried out (mounting, installation, service work, etc.), check to ensure that wiring is in an orderly state
- Fall or shock can adversely affect the safety functions. Such units must not be put into operation, even if they do not exhibit any damage.



Caution!

The safety, warning and technical notes given in the User Manual on the RWF50 (U7866) apply fully to the present document also!

Mounting notes

Ensure that the relevant national safety regulations are complied with.

Standards and certificates



Conformity to EEC directives

- Electromagnetic compatibility EMC (immunity) 2004/108/EC
- Low-voltage directive, to DIN EN 60730-1 2006/95/EC



ISO 9001: 2008
Cert. 00739



ISO 14001: 2004
Cert. 38233



Service notes

- For service purposes, the controller can be removed from its housing. This can however lead to damage of the housing
- The electrical connections are made via the fixing terminals on the rear of the housing

Disposal notes

The unit contains electrical and electronic components and must not be disposed of together with domestic waste.
Local and currently valid legislation must be observed.

Type summary

Compact universal controller	RWF50.20A9
- Basic version	
- 3-position output	
- Housing	
- Fixing frame and seal	
- User Manual	
- Single pack	
Compact universal controller	RWF50.30A9
- Basic version	
- Analog output	
- Housing	
- Fixing frame and seal	
- User Manual	
- Single pack	
Packaging variants (30 pieces, without User Manual)	RWF50.21A9 RWF50.31A9
PC software	ACS411

Technical Data

Inputs

Resistance thermometers

Type	Measuring range	Measuring accuracy ^a	Impact of ambient temperature
Pt100; DIN EN 60751	-200...850 °C (-328...1562 °F)	≤0.1%	50 ppm/K
Pt1000; DIN EN 60751	-200...850 °C (-328...1562 °F)	≤0.1%	50 ppm/K
LG-Ni1000	-50...+160 °C (-58...320 °F)	≤0.1%	50 ppm/K
0...135 Ω		≤0.25%	50 ppm/K

^a Accuracies relate to the maximum measuring range.

Line resistance Max. 30 Ω per line with 3-wire circuit

Line balancing Not required with 3-wire circuits.
With 2-wire circuits, line balancing can be performed by making an actual value correction

Input signals

Measuring range	Measuring accuracy ^a	Impact of ambient temperature
Voltage DC 0...10 V Input resistance RE >2 MΩ	≤0.1%	100 ppm/K
Voltage DC 0(1)...5 V Input resistance RE >2 MΩ	≤0.2%	200 ppm/K
Current 0(4)...20 mA Voltage drop ≤2 V	≤0.1%	100 ppm/K

^a Accuracies relate to the maximum measuring range.

Binary input D1

Potentialfree contact for the following functions, depending on the configuration:

- No function
- Setpoint readjustment
- Setpoint changeover
- Operating mode changeover

Monitoring the measuring circuit

In the event of error, the outputs assume defined states (configurable).

Measuring transducer	Measured value crossed limit	Sensor/line has short-circuit	Sensor/line interrupted
Resistance thermometer	●	●	●
Voltage 1...5 V 0...5 V, 0...10 V	● (●)	● ---	● ---
Current 4...20 mA 0...20 mA	● (●)	● ---	● ---

● = detected

(●) = detected only if measuring range is exceeded

- = not detected

Technical Data (cont'd)

Controller outputs OutP	Relay K1 (NO) 1P, 1N (burner release)	
	Contact rating	Max. 1 A at AC 250 V at $\cos\phi > 0.6$
	Contact life	100,000 switching cycles at high-fire
	Contact protection	Varistor
	Power supply for transducer G+, G-	DC 24 V $\pm 10\%$ /max. 25 mA short-circuit-proof

The following relay data are those specified by the supplier.

Only RWF50.2	Relay K2, KQ (controlling element OPEN)	
	Contact rating	Max. 1 A at AC 250 V and $\cos\phi > 0.6$
	Contact life	100,000 switching cycles at high-fire
	Contact protection	RC combination
	Relay K3, KQ (controlling element CLOSE)	
	Contact rating	Max. 1 A at AC 250 V at $\cos\phi > 0.6$
	Contact life	100,000 switching cycles at high-fire
	Contact protection	RC unit

Relay data are those specified by the supplier.

Only RWF50.3	Analog output A+, A-	
	Voltage	DC 0...10 V short-circuit-proof
	Load resistance	$R_{Last} \geq 500 \Omega$
	Accuracy	$\leq 0.25\%$, ± 50 ppm/K
	Current	0...20 mA/4...20 mA
	Load resistance	$R_{Last} \leq 500 \Omega$
	Accuracy	$\leq 0.25\%$, ± 50 ppm/K

Controller	Type of controller	
	- RWF50.2	Modulating controller
	- RWF50.3	Continuous controller
	Controller structure	P/PI/PD/PID
	Sampling time	250 ms

Electrical data	Power supply (switching network section)	AC 110...240 V $\pm 10\%$ -15% 48...63 Hz
	Electrical safety	To DIN EN 60730, part 1 Overvoltage category II Degree of contamination 2
	Power consumption	Max. 16 VA
	Data backup	EEPROM
	Electrical connection	At the rear via screw terminals
	- Cross-sectional area	0.25...1.5 mm ² fine-wired
	- Stranded wire with	- Ferrules to DIN 46228 - Pin-type cable socket to DIN 46231 - Crimp-type cable socket in fork-form for M3 thread (dimensions to DIN 46237)
	With UL applications	Use of the cable lug or ferrules to UL486A-B (UL listed or recognized)
	Tightening torque	0.5 Nm
	Electromagnetic compatibility	DIN EN 61326-1
	Emitted interference	Class B
	Immunity	Meeting industrial requirements

Technical Data (cont'd)

Housing	Type of housing	Made of Makrolon for control panel mounting to DIN IEC 61554 (use in indoor)
	Color	Light-grey RAL7035
	Mounting depth	92 mm
	Mounting position	Optional
	Degree of protection	To DIN EN 60529 Front side IP66 Rear IP20
	Weight	(Fully equipped)
	- RWF50.2	Approx. 170 g
	- RWF50.3	Approx. 168 g
Environmental conditions	Storage	DIN IEC 60721-3-1
	Climatic conditions	Class 1K3
	Mechanical conditions	Class 1M2
	Temperature range	-40...70 °C
	Humidity	<95% r.h.
	Transport	DIN IEC 60721-3-2
	Climatic conditions	Class 2K2
	Mechanical conditions	Class 2M2
	Temperature range	-40...70 °C
	Humidity	<95% r.h.
	Operation	DIN IEC 60721-3-3
	Climatic conditions	Class 3K3
	Mechanical conditions	Class 3M3
	Temperature range	-20...50 °C
	Humidity	<95% r.h.
Installation altitude	Max. 2,000 m above sea level	



Attention!

Condensation, formation of ice and ingress of water are not permitted!

Segment display

Height of numerals	
- Upper display	10 mm
- Lower display	7 mm
Color	
- Upper display	Red
- Lower display	Green
Digits	4 (including 0, 1 or 2 decimal places, configurable)
Range of display	-1999...9999

Function

The following functions are included in the RWF50:

- **Digital PID controller** with a 3-position or analog output of the calculated output level
- The controller can be switched to a 2-position controller for controlling 2-stage burners
- Automatic **thermostat (or pressure controller) function** in low-fire operation
- **Minimum limiter and maximum limiter** for the boiler temperature or boiler pressure
- Manual operating mode
- Self-setting function
- Parameterization and visualization via USB interface and PC software ACS411
- Ramp functions (cold start/thermal shock protection)
- Heating/cooling

Block structure

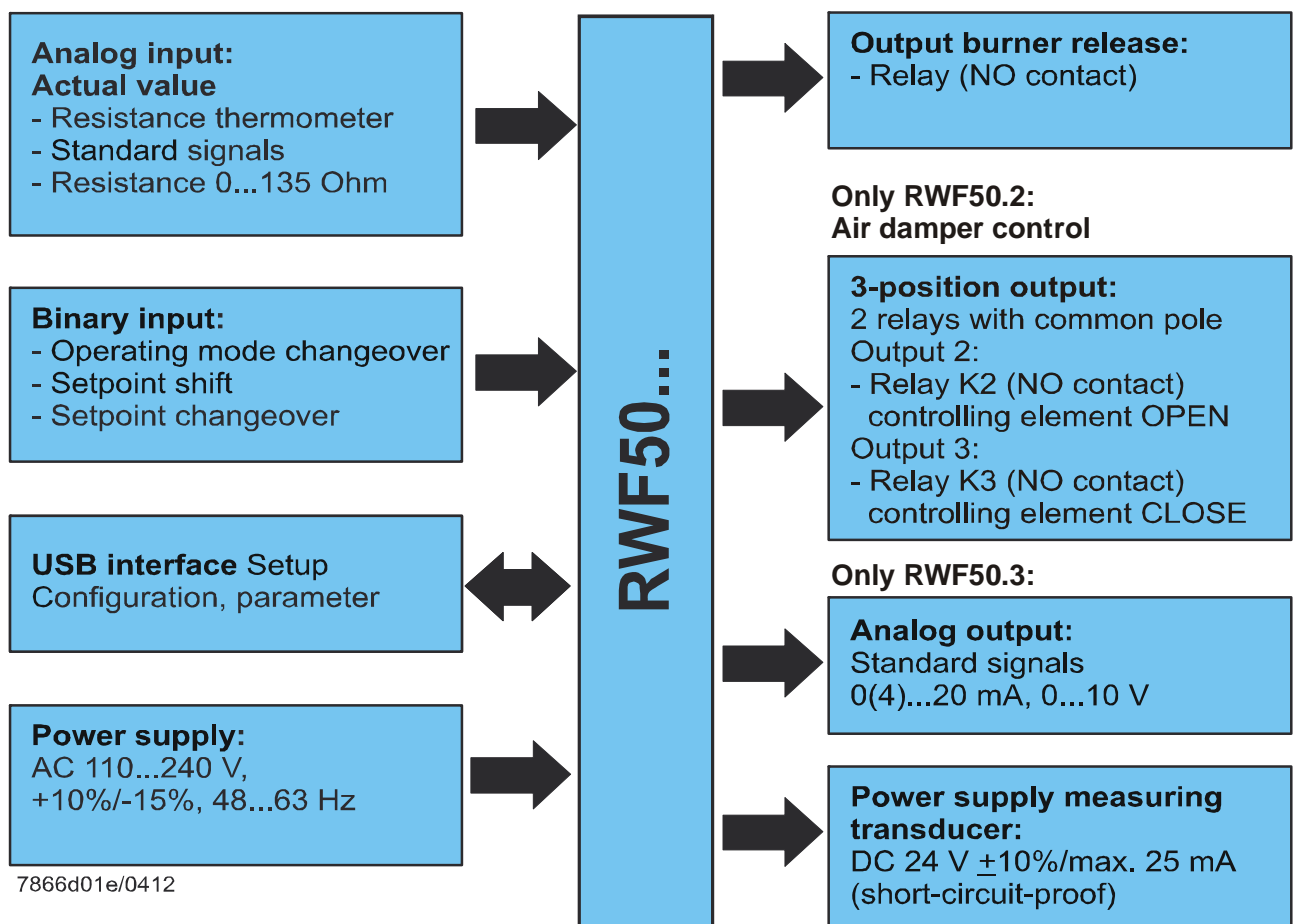

Function of the controller when used for burner control

Low-fire operation	Low-fire operation means that only small amounts of energy are drawn from the boiler. With the relay 1 burner release, the 2-position controller controls the set setpoint by switching the burner on and off like a thermostat. An adjustable switching differential ensures that the burner's switching frequency can be selected to help protect the material.
High-fire operation	High-fire operation means that large amounts of energy are drawn from the boiler with the burner running continuously. The RWF50 controls the required output using the 3-position or analog output.
Operation	The RWF50 is operated and programmed with 4 buttons on the front of the unit. During operation and programming, the 7-segment displays show the parameter value and parameter name.
Analog input	To acquire the actual value, a number of sensors can be connected to the RWF50.

		Measuring range
Resistance thermometer	Pt100	-200...+850°C (-328...+1562 °F)
in 2-wire or	Pt1000	-200...+850°C (-328...+1562 °F)
3-wire technology	LG-Ni1000	-50...+160°C (-58...+320 °F)
Linearized standard signals	0...135 Ohm	scalable -1999...+9999
	0...20 mA	scalable -1999...+9999
	4...20 mA	scalable -1999...+9999
	DC 0...10 V	scalable -1999...+9999
	DC 0...5 V	scalable -1999...+9999
	DC 1...5 V	scalable -1999...+9999

The power provided for the measuring transducers is DC 24 V ±10% / max. 25 mA.

Connection diagram

RWF50.2

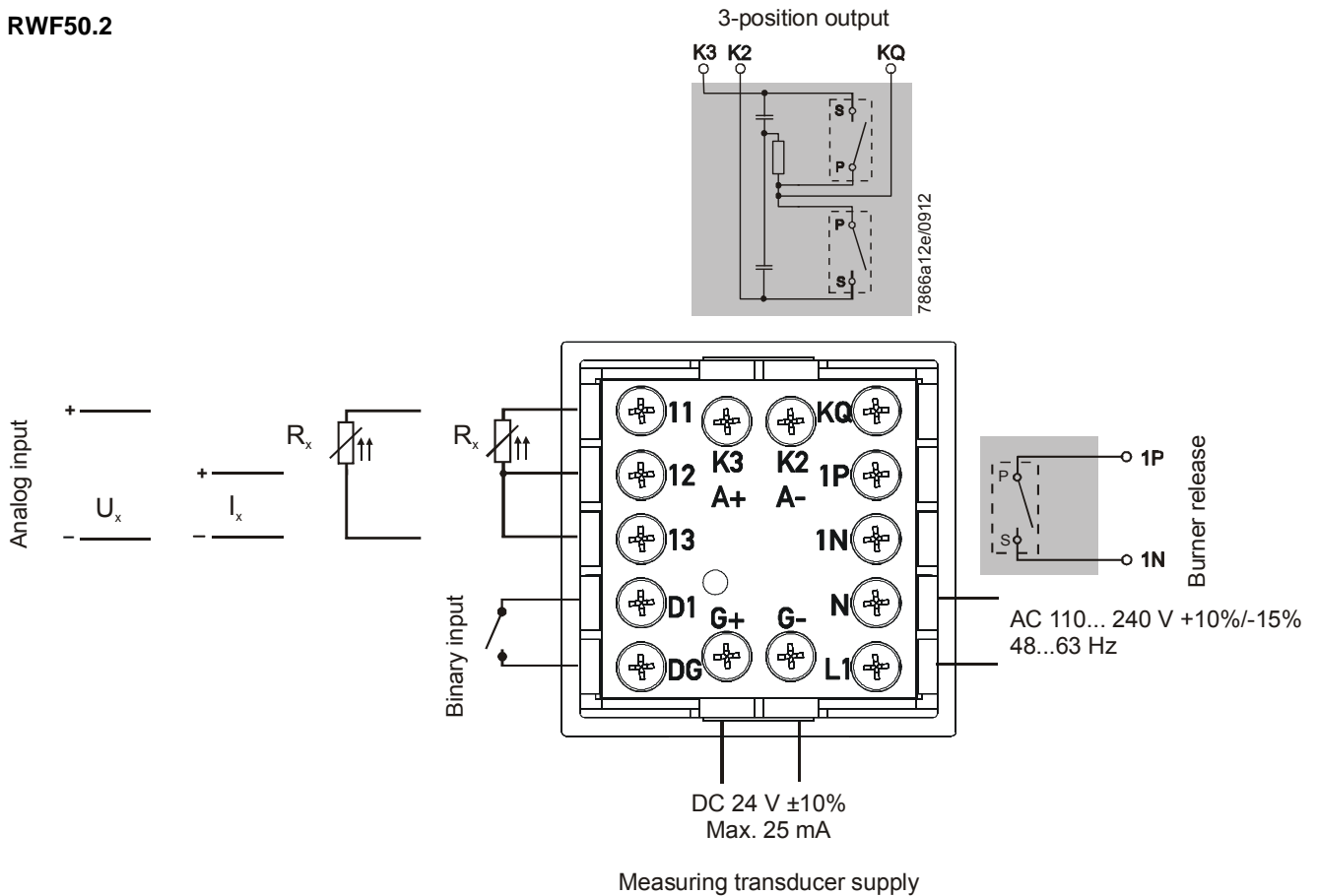

Legend

 The RWF50 contains these components

- I_x Current input
- K2 Relay: Controlling element OPEN
- K3 Relay: Controlling element CLOSED
- KQ common pole
- 1N Relay K1: NO-contact
- S NO-contact
- P Pole
- 1P Relay K1: Pole
- R_x Resistance
- U_x Power supply input

Connection diagram (cont'd)

RWF50.3

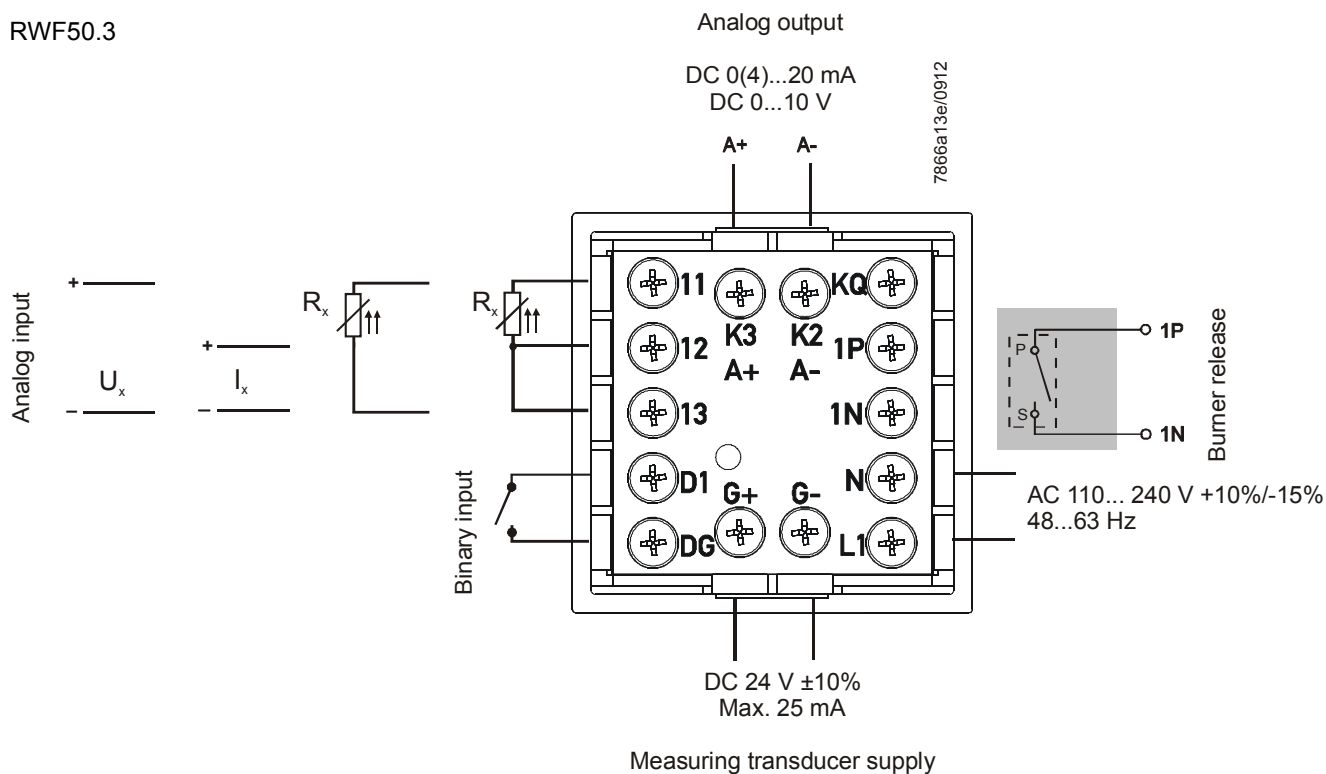

Legend

	The RWF50 contains these components
A+	Analog output (+)
A-	Analog output (-)
I _x	Current input
1N	Relay K1: NO-contact
S	NO-contact
P	Pole
R _x	Resistance
1P	Relay K1: Pole
U _x	Power supply input

Dimensions

Dimensions in mm

