

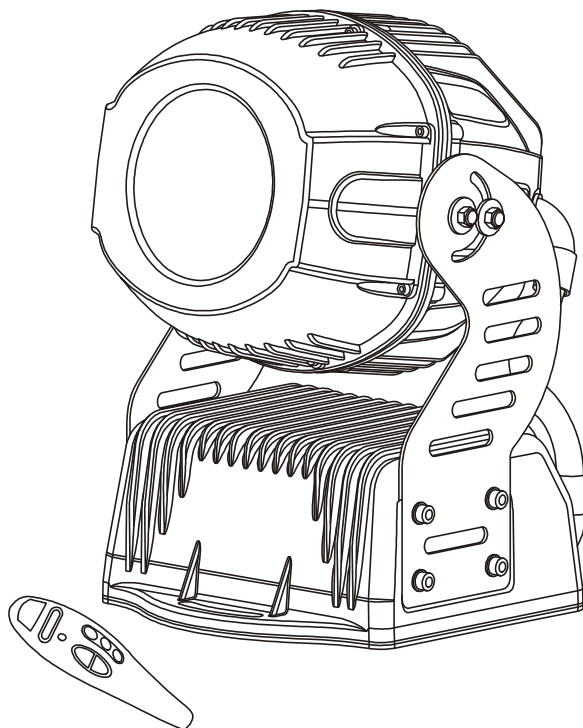

Outdoor Colour Changer
Ecolor 250^{XT}



USER MANUAL

XT series

ROBE
show lighting

www.robe.cz



ECOLOR 250 XT

Table of contents

1. Safety instructions	3
2. Operating determinations	4
3. Description of the device	5
4. Installation	7
4.1 Fitting/Exchanging the lamp	7
4.2 Lamp adjustment	7
4.3 Manually adjustment of the effects	8
4.4 Rigging	9
4.5 Connection to the mains	10
4.6 DMX- 512 connection, master/slave connection	11
5. DMX Protocol-8 bit	12
6. Control of the fixture	13
7. Controller mode	13
7.1 DMX addressing	13
7.2 Remotely and manually controllable functions	14
8. Stand - alone mode	14
9. Functions of the control panel	16
9.1 Addressing	16
9.2 Slave control	17
9.3 Fixture informations	17
9.4 Personality options	18
9.5 Switching On/Off the lamp	21
9.6 Test sequences	21
9.7 Stand-alone setting	22
9.8 Reset function	25
9.9 Special functions	26
10. Error and information messages	28
11. Technical specifications	28
12. Maintenance and cleaning	30
13. Appendix	32

CAUTION!

***Keep this device away from rain and moisture!
Unplug mains lead before opening the housing!***

**FOR YOUR OWN SAFETY, PLEASE READ THIS USER MANUAL CAREFULLY
BEFORE YOU INITIAL START - UP!**

1. Safety instructions

Caution ! Be careful with your operations. With a dangerous voltage you can suffer a dangerous electric shock when touching the wires

This device has left our premises in absolutely perfect condition. In order to maintain this condition and to ensure a safe operation, it is absolutely necessary for the user to follow the safety instructions and warning notes written in this manual.

Important:

Damages caused by the disregard of this user manual are not subject to warranty. The dealer will not accept liability for any resulting defects or problems.

If the device has been exposed to drastic temperature fluctuation (e.g. after transportation), do not switch it on immediately. The arising condensation water might damage your device. Leave the device switched off until it has reached room temperature.

This device falls under protection-class I. The power plug must only be plugged into a protection class I outlet. Never let the power-cord come into contact with other cables! Handle the power-cord and all connections with the mains with particular caution!

Make sure that the power-cord is never crimped or damaged by sharp edges. Check the device and the power-cord from time to time.

Always disconnect from the mains, when the device is not in use or before cleaning it.

During the initial start-up some smoke or smell may arise. This is a normal process and does not necessarily mean that the device is defective.

Caution: During the operation, the housing becomes very hot.

Do not switch the device on and off in short intervals as this would reduce the lamp's life.

HEALTH HAZARD!

Never look directly into the light source, as sensitive persons may suffer an epileptic shock (especially meant for epileptics) !

Please consider that damages caused by manual modifications to the device are not subject to warranty.

Keep away children and amateurs !

2. Operating determinations

This device is an architectural luminaire for creating decorative effects and was designed for outdoor use.

Never run the device without lamp!

Do not shake the device. Avoid brute force when installing or operating the device.

Weatherized design to IP65.

When choosing the installation-spot, please make sure that the device is not exposed to extreme heat, moisture or dust. There should not be any cables lying around. You endanger your own and the safety of others!

The minimum distance between light-output and the illuminated surface must be more than 1,0 meter.

Make sure that the area below the installation place is blocked when rigging, derigging or servicing the fixture.

The exterior of the fixture becomes very hot, up to 110°C. Do not place the fixture in areas where accidental contact is likely.

Only operate the fixture after having checked that the housing is firmly closed and all screws are tightly fastened.

The lamp must never be ignited if the objective-lens or any housing-cover is open, as discharge lamps may explode and emit a high ultraviolet radiation, which may cause burns.

The maximum ambient temperature $t_a = 40^\circ\text{C}$ must never be exceeded.

CAUTION!

The lens has to be replaced when it is obviously damaged, so that its function is impaired, e. g. due to cracks or deep scratches!

Operate the device only after having familiarized with its functions. Do not permit operation by persons not qualified for operating the device. Most damages are the result of unprofessional operation!

CAUTION!

The lamp has to be replaced when it is damaged or deformed due to the heat!

Please use the original packaging if the device is to be transported.

Please consider that unauthorized modifications on the device are forbidden due to safety reasons!

Never remove the serial barcode from the device as this would make the guarantee void.

If this device will be operated in any way different to the one described in this manual, the product may suffer damages and the guarantee becomes void. Furthermore, any other operation may lead to dangers like short-circuit, burns, electric shock, lamp explosion, crash etc.

3. Description of the device

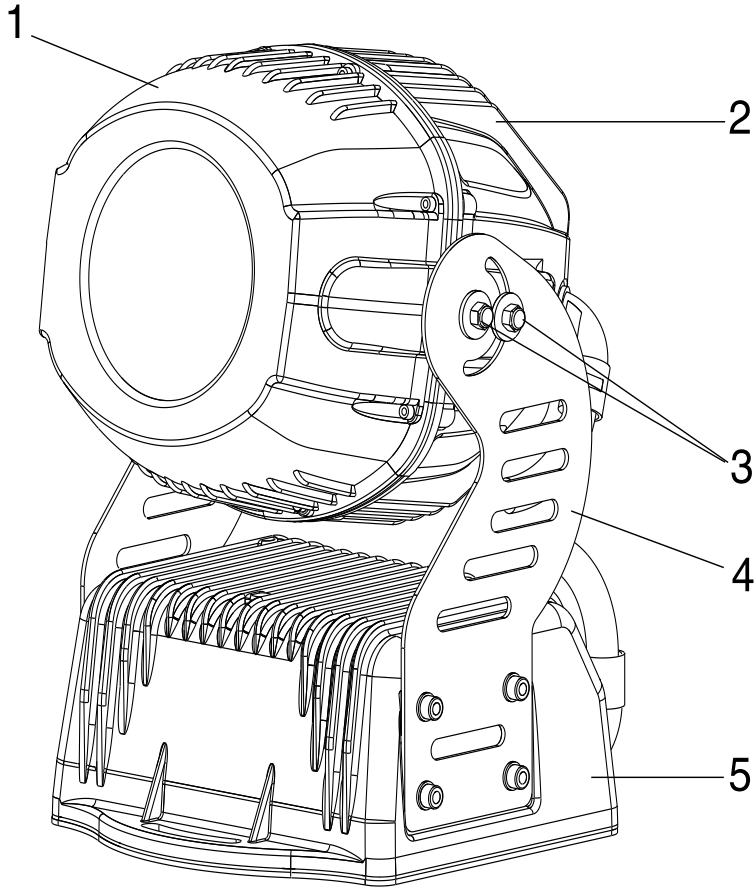

Front side

- 1 - Front cover of the head
- 2 - Rear cover of the head
- 3 - Bracket bolts
- 4 - Head bracket
- 5 - Base

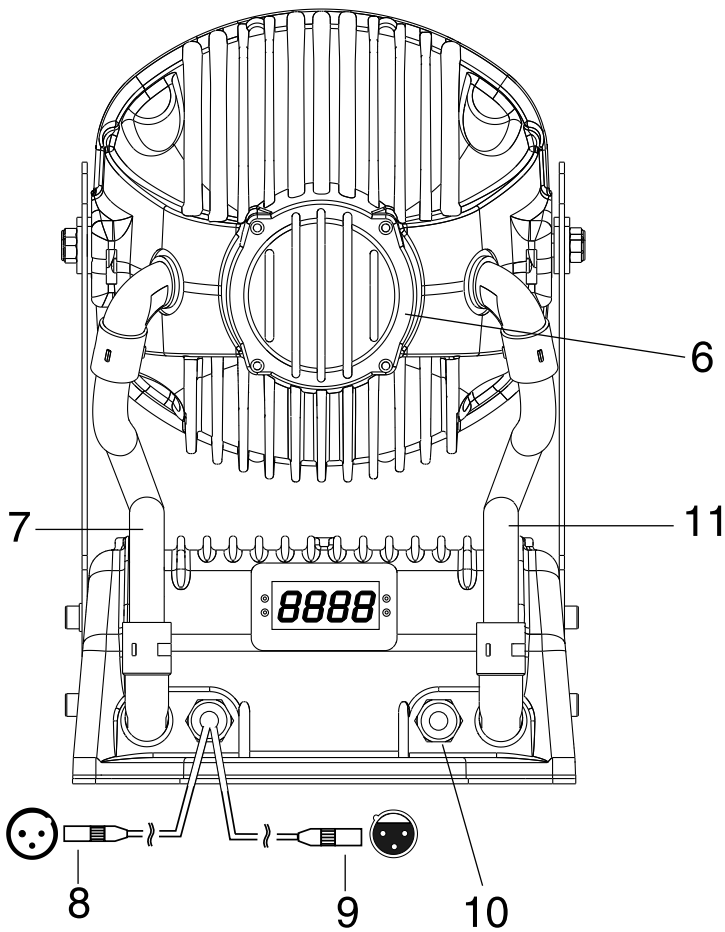

Rear side

- 6 - Lamp cover
- 7 - Patchcord
- 8 - DMX input
- 9 - DMX output
- 10 - Powercord
- 11 - Patchcord

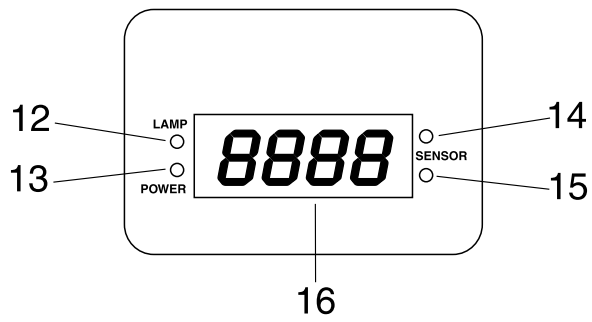

Display board

- 12 - Green LED
- 13 - Red LED
- 14 - Infra-red transceiver
- 15 - Light sensor
- 16 - Display

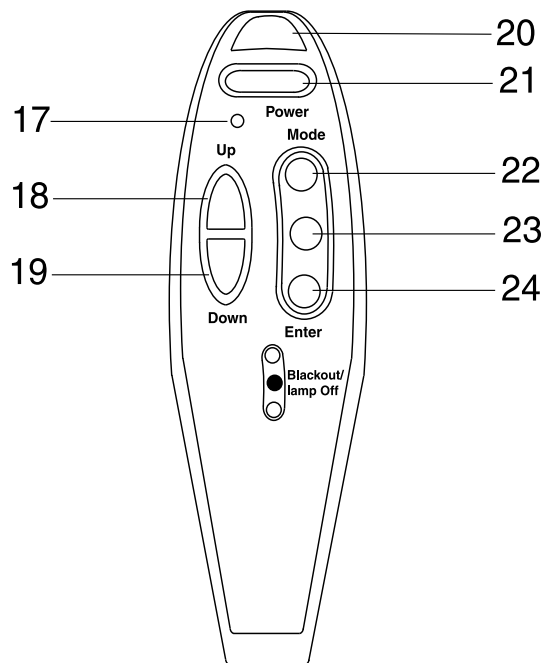

- 17 - Red LED
- 18 - Up-button
- 19 - Down-button
- 20 - Infra-red transmitter
- 21 - Lamp On-button
- 22 - Mode-button
- 23 - Blackout/lamp off-button
- 24 - Enter-button

4. Installation

4.1 Fitting/Exchanging the lamp

***DANGER !
Unplug from mains before !***

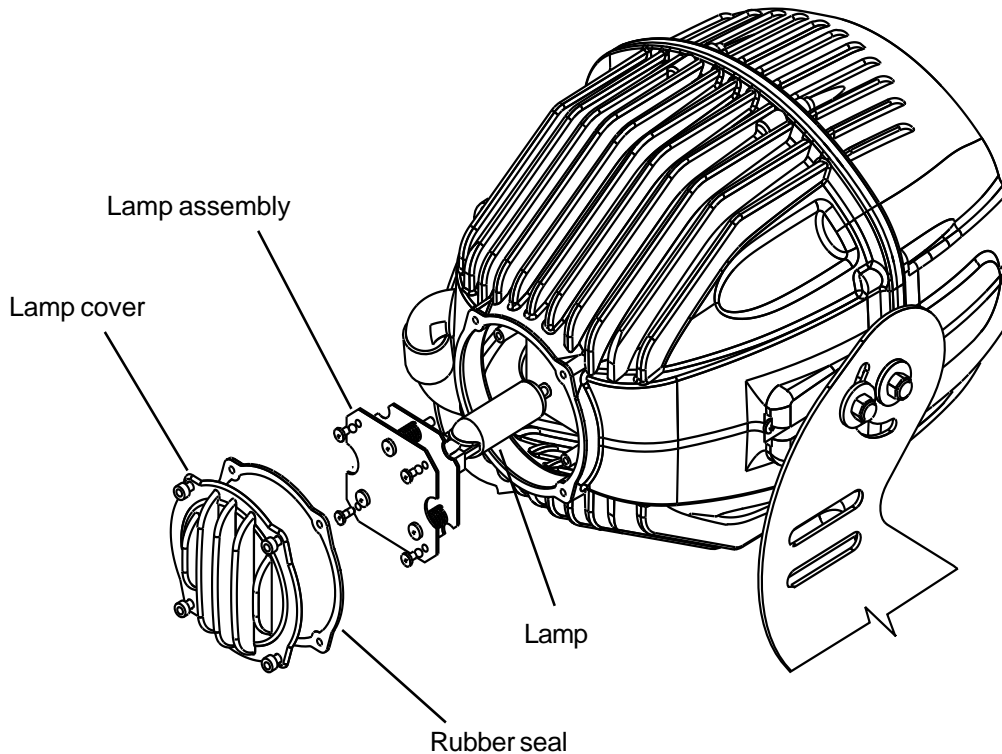

Allow the lamp to cool for 20 minutes before removing the lamp cover

To insert the lamp MSD/HSD 250 open the small cover at the rear of the projection-head (see the drawing) by loosening the 4 screws on the cover. Remove the rubber seal. Loose the 4 screws ("V,X,Y,Z") on the lamp assembly and gently pull the lamp assembly out. If changing the lamp, remove the old lamp from the socket. Insert the lamp to the socket.

Do not install a lamp with a higher wattage! A lamp like this generates temperatures the device is not designed for.

Damages caused by non-observance are not subject to warranty. Please follow the lamp manufacturer's notes! Do not touch the glass bulb with bare hands during the installation! Make sure that the lamp is installed tightly into the lampholder system.

Reinsert the lamp assembly and tighten the 4 screws ("V,X,Y,Z"). Close the small lamp cover with the seal by tighten the 4 fastening screws again.

Before striking the lamp, reset the "LAt/rSEt" and "LAsT/rSEt"- counter in the "InFO" menu of the fixture, by pressing the "Up" and "Down" buttons in one time and then confirming with the "Enter"-button on the remote control.

Do not operate this fixture with opened housing-cover!

4.2 Lamp adjustment

The fixture lampholder is aligned at the factory. Due to differences between lamps, fine adjustment may improve light performance.

Open the lamp cover at the rear of the projection-head by loosening the 4 screws on the cover. Remove the rubber seal.

Strike the lamp, cancel all effects, set the dimmer intensity onto 100 % and focus the light on a flat surface (wall) or use function "LAAd" in the **Special functions** .

Adjust the lamp until the light is even using the 3 adjustment screws "A, B, C" on the lamp assembly. Turn one screw at a time to distribute the light evenly.

To reduce a hot-spot, pull the lamp in by turning all three screws "A, B, C" clockwise 1/4-turn at a time until the light is evenly distributed.

If the light is brighter around the edge than it is in the center, or if light output is low, the lamp is too far back in the reflector. „Push" the lamp out by turning the screws "A, B, C" counterclockwise 1/4-turn at a time the light is bright and evenly distributed.

Close the lamp cover with the seal by tighten the 4 fastening screws again.

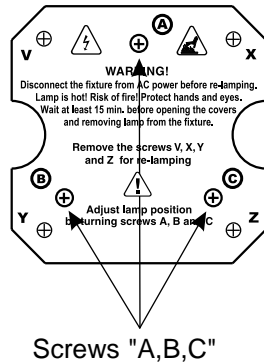

4.3 Manually adjustment of the effects

Zoom

The lens system can be configured in the range between 8° and 22° beam angles. To set the desired beam angle, open the front cover by loosening the 8 screws, remove the rubber seal, loose the 2 adjusting screws on the fresnel lens unit and adjust the required beam angle. Tighten the adjusting screws again and fix the front cover with the rubber seal.

Beam shapers, frost filter, colour temperature correction filter 3200K

Open the front cover by loosening the 8 screws, remove the rubber seal. Loosen the 2 adjusting screws on the desired module and set the suitable effect (vertical and horizontal beam shaper, frost filter, 3200K temperature filter). Tighten the adjusting screws again and fix the front cover with the rubber seal back.

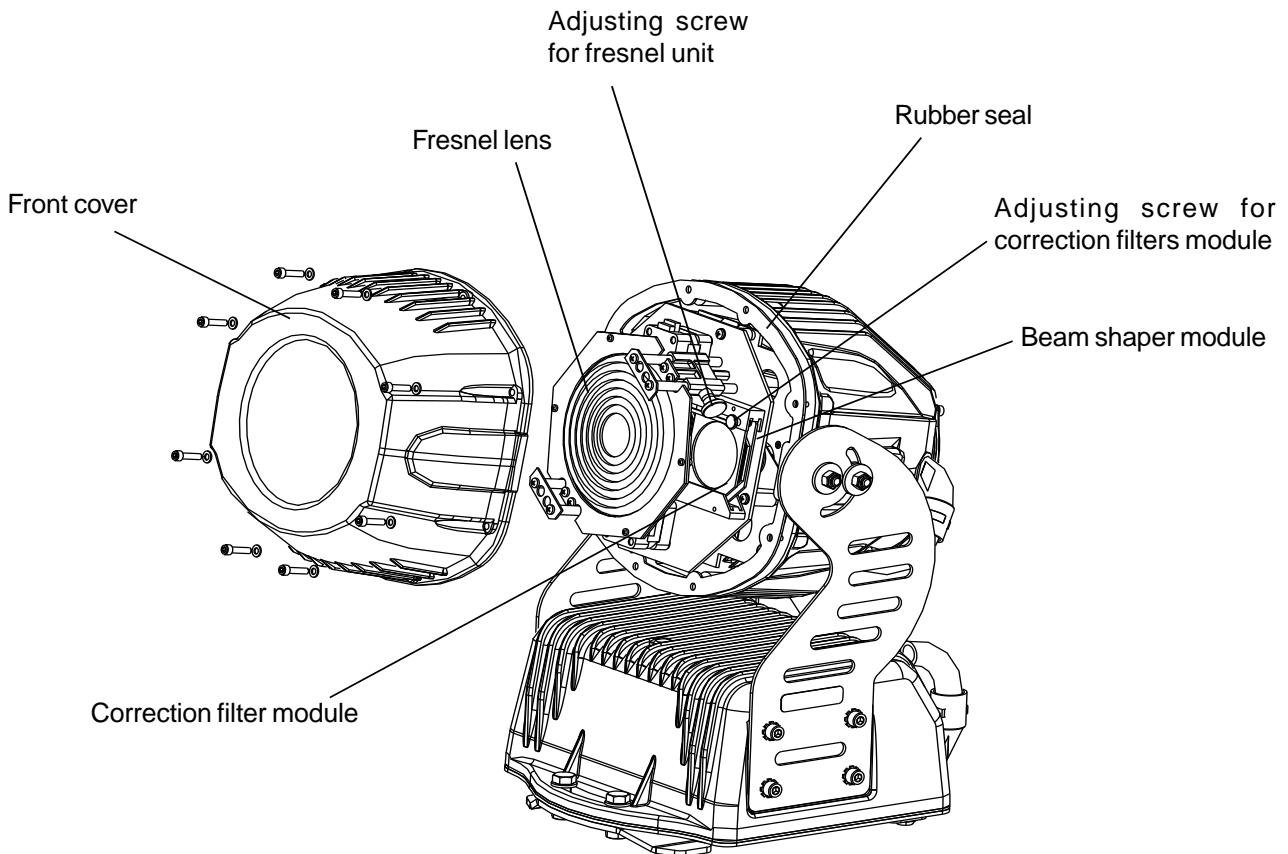

4.4 Rigging

DANGER TO LIFE!
Please consider the respective national norms during the installation! The installation must only be carried out by an authorized dealer!

The installation of the fixture has to be built and constructed in a way that it can hold 10 times the weight for 1 hour without any harming deformation.

When rigging, derigging or servicing the fixture staying in the area below the installation place, on bridges, under high working places and other endangered areas is forbidden.

The operator has to make sure that safety-relating and machine-technical installations are approved by an expert before taking into operation for the first time and after changes before taking into operation another time.

The operator has to make sure that safety-relating and machine-technical installations are approved by a skilled person once a year.

The fixture should be installed outside areas where persons may walk by or be seated.

IMPORTANT! OVERHEAD RIGGING REQUIRES EXTENSIVE EXPERIENCE, including (but not limited to) calculating working load limits, installation material being used, and periodic safety inspection of all installation material and the fixture. If you lack these qualifications, do not attempt the installation yourself, but instead use a professional structural rigger. Improper installation can result in bodily injury and or damage to property.

The fixture has to be installed out of the reach of people.

If the fixture shall be lowered from the ceiling or high joists, professional trussing systems have to be used. The projector must never be fixed swinging freely on the mounting place.

Caution: Fixtures may cause severe injuries when crashing down! If you have doubts concerning the safety of a possible installation, do NOT install the projector!

The fixture can stand directly on the floor by standing on the 2 removable stands which are mounted with the 4 bolts M10 to the fixture's base. If you demount this stands, the fixture's base enables the fixture to be mounted with the screws M10 through the 12 mm slot to the desired site.

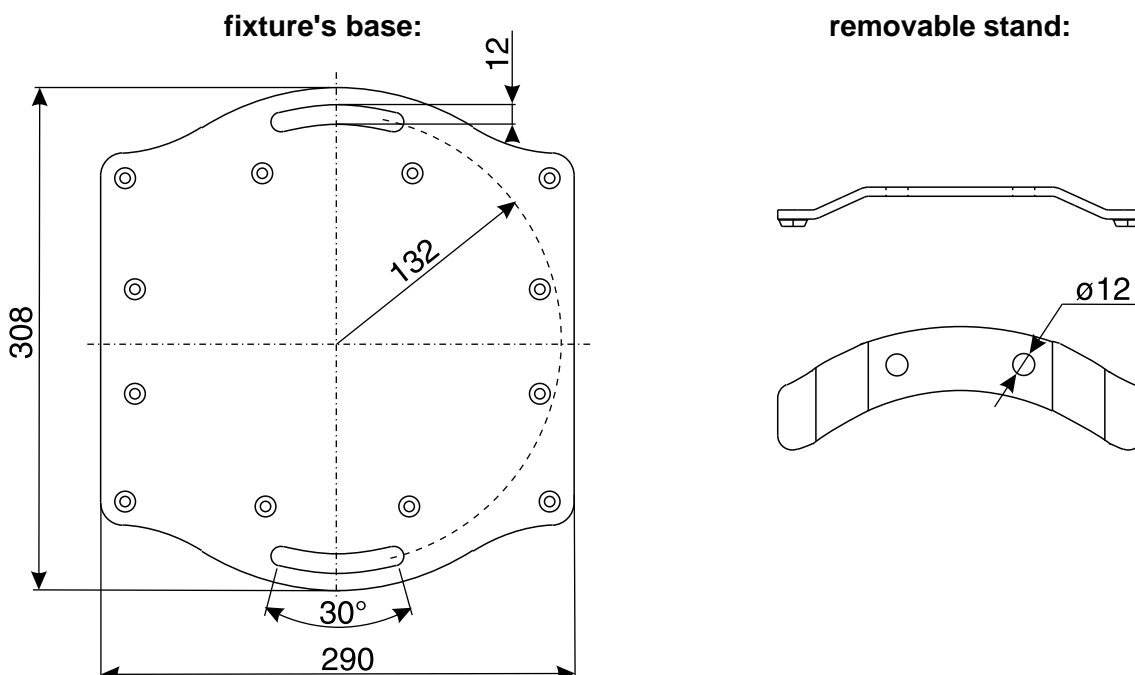

Danger of fire !
When installing the device, make sure there is no highly inflammable material (decoration articles, etc.) in between a distance of min. 1,0 m.

CAUTION!
Follow the instructions mentioned at the bottom of the base.
Make sure that the device is fixed properly! Ensure that the structure (truss) to which you are attaching the fixtures is secure.

Before rigging make sure that the installation area can hold a minimum point load of 10 times the projector's weight.
 Install the fixture away from accidental public contact.

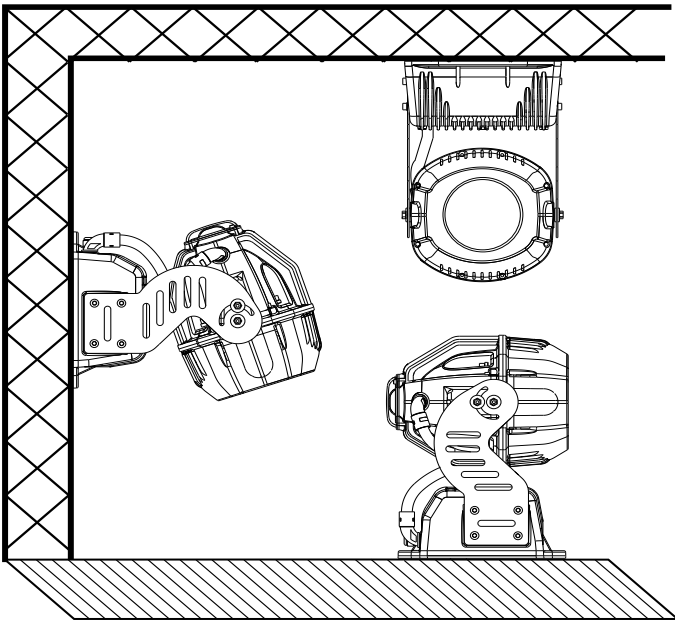

The fixture is rated to IP65 and may be mounted in any orientation without altering its operation characteristics (see the drawing). The fixture's head can be adjusted in a vertical range 130°.

Allow the fixture to cool before handling!

DANGER TO LIFE!
Before taking into operation for the first time, the installation has to be approved by an expert!

4.5 Connection to the mains

Connect the fixture to the mains with the protected and weatherproof power-plug.
 The earth has to be connected!

The occupation of the connection-cables is as follows:

Cable (EU)	Cable (US)	Pin	International
Brown	Black	Live	L
Light blue	White	Neutral	N
Yellow/Green	Green	Earth	

4.6 DMX- 512 connection, master/slave connection

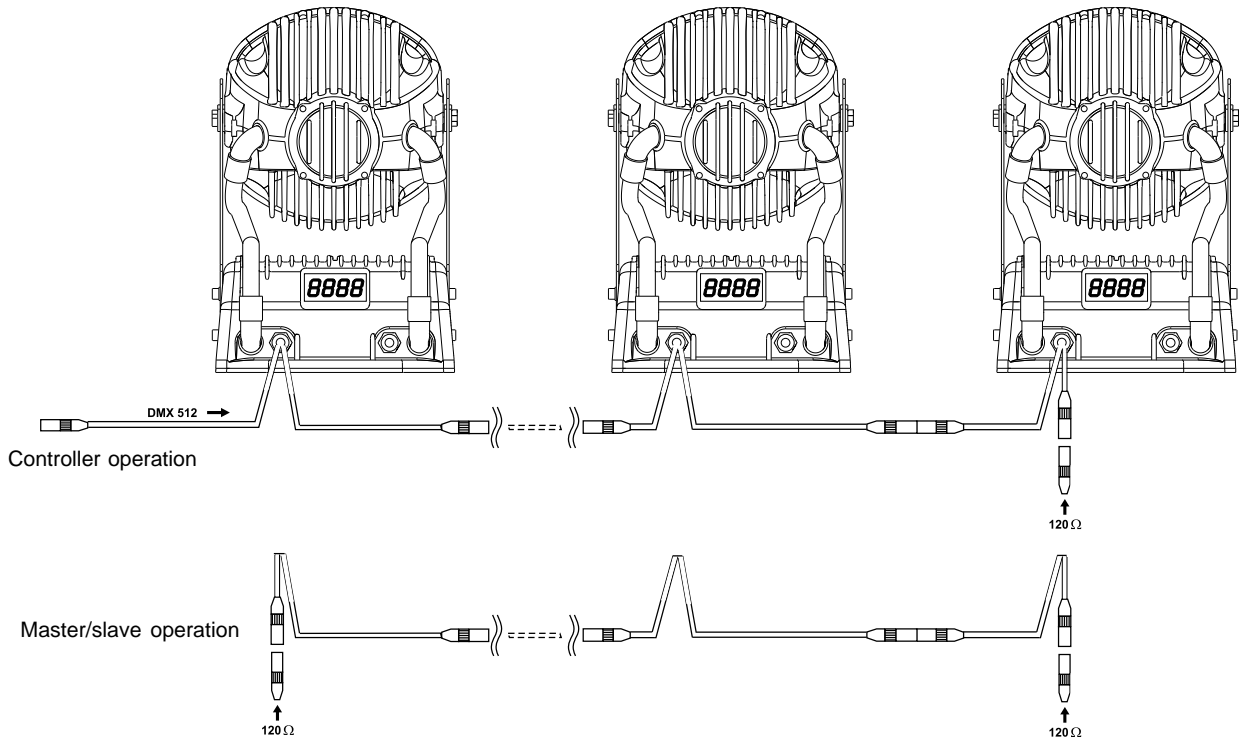

The wires must not come into contact with each other, otherwise the fixtures will not work at all, or will not work properly.

Only use a RS-485 data cable and 3-pin XLR connectors in order to connect the controller with the fixture or one fixture with another. The connectors must be protected in a weatherproof housing.

Occupation of the XLR-connection:

**DMX - output
XLR mounting-socket:**



- 1 - Ground
- 2 - Signal (-)
- 3 - Signal (+)

**DMX-input
XLR mounting-plug:**



- 1 - Ground
- 2 - Signal (-)
- 3 - Signal (+)

Building a serial DMX-chain:

If you are using the standard controllers, you can connect the DMX-output of the controller directly with the DMX-input of the first fixture in the DMX-chain. If you wish to connect DMX-controllers with other XLR-outputs, you need to use adapter-cables.

Connect the DMX-output of the first fixture in the DMX-chain with the DMX-input of the next fixture. Always connect output with the input of the next fixture until all fixtures are connected.

Caution: At the last fixture, the DMX-cable has to be terminated with a terminator. A termination plug is an XLR connector with a 120 ohm resistor soldered across pins (+) and (-).

Building a master/slave-chain:

Connect the DMX-output of the master fixture in the data-chain with the DMX-input of the first slave. Always connect output with the input of the next slave until all slaves are connected (up to 9 fixtures).

Caution: It's necessary to insert the XLR termination plug (with 120 Ohm) into the input of the master fixture and into the output of the last slave fixture in the link in order to ensure proper transmission on the data link.

5. DMX Protocol-8 bit

Channel	Value	Function	Type of control
1	0-255	Cyan Cyan from 0 (white) to 255 (full cyan)	proportional
2	0-255	Magenta Magenta from 0 (white) to 255 (full magenta)	proportional
3	0-255	Yellow Yellow from 0 (white) to 255 (full yellow)	proportional
4	0-255	Dimmer intensity Intensity from 0 to 100%	proportional
5	0-255	Speed of CMY and dimmer From max. speed to min. speed	proportional
6	0-7 8-15 16-23 24-31 32-39 40-47 48-55 56-63 64-71 72-79 80-87 88-95 96-103 104-111 112-119 120-127 128-139 140-229 230-239 240-255	Colour macros,Lamp On/Off,Reset Off Macro 1 Macro 2 Macro 3 Macro 4 Macro 5 Macro 6 Macro 7 Macro 8 Macro 9 Macro 10 Macro 11 Macro 12 Macro 13 Macro 14 Macro 15 Lamp On after 3 sec.,reset No function Lamp Off after 3 sec No function	step step step step step step step step step step step step step step step step step step step

6. Control of the fixture

The ECOLOR 250 XT is controlled by infra-red 6-buttons remote control and 4-digit LED display on the rear side of the fixture. You can simply set the lighting address, operating mode, read the number of the lamp or unit hours, switch On and Off the lamp, run programs, make a reset and also use special functions for manual and service purposes.

Two LEDs on the rear panel display the fixture status. Red LED indicates normal operation after switching the fixture on. Green LED indicates the lamp is switched on.

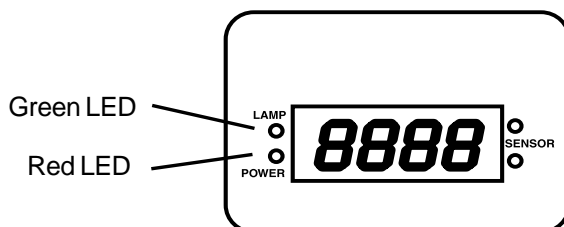

The red LED on the remote control indicates if any button is pressed (the signal is transmitted). There are the 2 buttons on the remote control which have a special function: [Power]-button and [Blackout/lamp Off]-button.

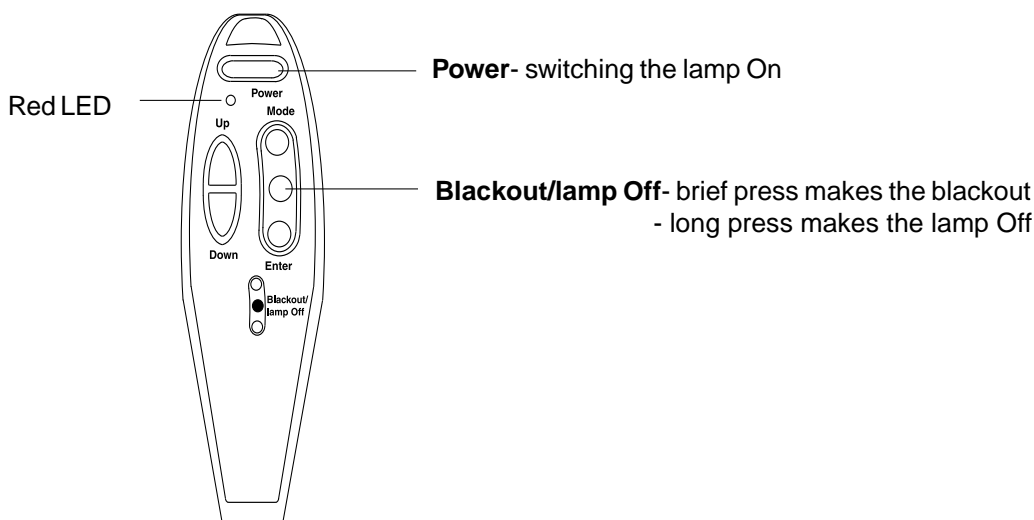

The ECOLOR 250 XT can be operated with a controller in **controller mode** or without the controller in **stand-alone mode**.

Both modes are described in the texts below.

7. Controller mode

The fixtures are individually addressed (001-507) on a data link and connected to the controller. The fixtures respond to the DMX signal from the controller.

7.1 DMX addressing

The remote control allows you to assign the DMX fixture address, which is defined as the first channel from which the ECOLOR 250 XT will respond to the controller.

If you set, for example, the address to channel 5, the ECOLOR 250 XT will use the channel 5 to 10 for control. Please, be sure that you don't have any overlapping channels in order to control each ECOLOR 250 XT correctly and independently from any other fixture on the DMX data link.

If two, three or more ECOLOR 250 XT are addressed similarly, they will work similarly. For address setting, please refer to the instructions under "Addressing"(menu "A001").

Controlling:

After having addressed all ECOLOR 250 XT , you may now start operating these via your lighting controller.

Note:After switching on, the ECOLOR 250 XT will automatically detect whether DMX 512 data is received or not.If there is no data received at the DMX-input, the display will start to flash "**A001**" with actually set address. This situation can occur if:

- the 3 PIN XLR plug (cable with DMX signal from controller) is not connected with the input of the ECOLOR 250 XT
- the controller is switched off or defective, the cable or connector is defective or the signal wires are swap in the input connector.

Note:It's necessary to insert the XLR termination plug (with 120 Ohm) to the last fixture in the link in order to ensure proper transmission on the DMX data link.

7.2 Remotely and manually controllable functions

Lamp

The ECOLOR 250 XT is to be operated with a MSD/HSD 250 or MSD 250/2 lamp.

A relay inside of the ECOLOR 250 XT allows you to switch on and off the lamp via the remote control or via your DMX-controller without affecting the rest of the lighting.

To switch On/Off the lamp,use the **[Power]**-button or **[Blackout/lamp Off]**-button on the remote control .You can use also menu "**LAMP**"- please refer to "Switching On/Off the lamp ".

Note: It is also important to note, that the discharge lamp is cold restrike types, that means, that they have to be cold before re-striking. For this reason, you have to wait 5 minutes (after having switched Off the lamp before you can switch it back On again. If you try to switch On the lamp within 5 minutes after having switched it Off, the ECOLOR 250 XT will store this information and automatically ignite the lamp when the 5 minutes period has expired. The message "**HEAT**" will appear on the control board display of the ECOLOR 250 XT. If the ignition of the lamp is seven times unsuccessful, on the display will appear "**LA.Er.**", meaning that the lamp could be damaged or even missed, or there could be a failure on the ignitor or ballast.

Avoid turning on several lamps at once.

CMY-colors mixing system

The CMY color mixing system is based on graduated cyan,magenta and yellow color filters.A continuous range of colours may be achived by varying the amount of each filter from 0 to 100%

Dimmer

Smooth 0-100% dimming is provided by the special dimmer unit.

Beam effects

Horizontal and vertical beam shapers – manually adjustable.Frost filter for softer beam and colour temperature correction filter 3200K – manually adjustable.

Clock

The ECOLOR 250 XT has a battery operated 24-hour clock that can set the start and the stop stand-alone operation.

Cooling

The ECOLOR 250 XT is cooled by one axial fan in the head.

8. Stand - alone mode

The fixtures on a data link are not connected to the controller but can execute pre-set programs which can be different for every fixture.To set the program to be played,see the "Stand-alone setting" (menu "**St.AL.**").

"Stand-alone operation" can be applied to the single fixture (the fixture may be set to the master /slave mode) or to multiple fixtures operating synchronously.

Synchronous operation of multiple fixtures requires that they must be connected on a data link and one of them is set as a master (master mode) and the rest as the slaves (slave mode).The slaves are assigned to SLA.1-SLA.9 and on the certain slave address can be connected only one fixture.To set the fixture as the master or slave , see the "Addressing" (menu "**A001**").

If the master fixture runs a reset,switches On/Off the lamp or plays test(program) ,all slaves will execute these acts too (e.g. if the master fixture has switched its lamp off,no slave can switch its lamp on)!

You can't play or edit any programs on the slaves by their control displays if the master is switched on and connected to the master/slave chain.

The master fixture starts simultaneous program start in the other slave fixtures. All fixtures have a definite, synchronized starting point when playing back their programs. The number of running program is the same in all slaves and depends on the master's choice (menu "St.AL. "). Every fixture runs its program repeatedly, starting the program step No. 1 when requested by the master.

For example:

If the slave fixture has a shorter program length, it will continuously repeat its program until the master fixture finishes its own program and restarts its program running (slave 1- prog.step 3 will not be finished).

If the slave fixture has a longer program length, it will restart at prog. step 1 before it completes all its prog.steps (slave 2 - prog.step 5 will not be played)- see the picture below.

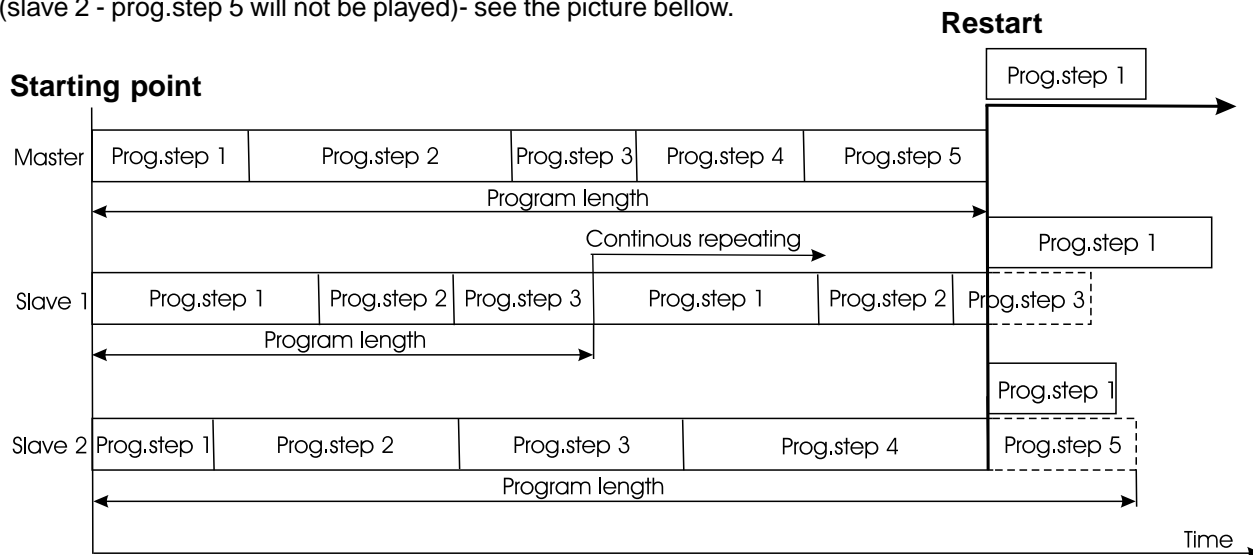

Stand-alone operation can be set for one or two periods during a 24 hour period, using the built-in clock or for a light level, using the built-in light sensor. If both the clock and the light sensor are active, operation starts within the set times or if it is darker than the light-level setting. Operation stops at the stop times or if that the ambient light is brighter than the set light level.

If the time periods overlap each other or if the time period overlaps the light level period, the fixture will respond to the events according to their rank.

For example:

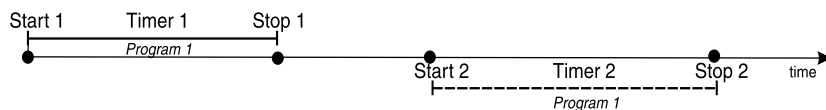

All events will be executed (Start1, Stop1, Start2, Stop2).

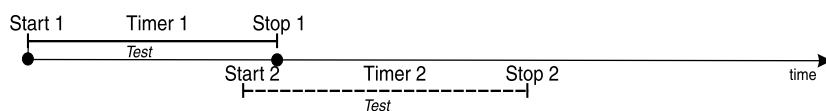

The events Start 1 and Stop 2 will be executed only.

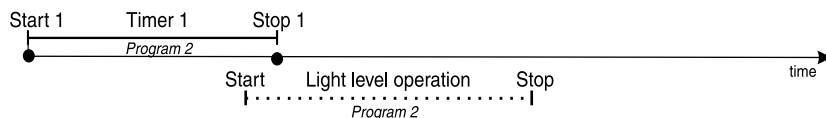

The events Start 1 and Stop will be executed only.

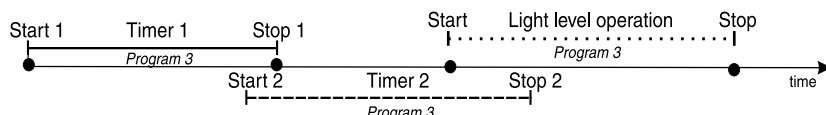

The Time period 1 and Light period will be executed, the Time period 2 is eliminated.

The played program is the same for all time(light level) periods.

From the master's control panel is possible to control any slave in a master/slave chain.

Note: Disconnect the fixtures from the DMX controller before master/slave operating, otherwise data collisions can occur and the fixtures will not work properly!

Note: It's necessary to insert the XLR termination plug (with 120 Ohm) into the input of the master fixture and into the output of the last slave fixture in the data link in order to ensure proper transmission on the data link.

9. Functions of the control panel

The control panel situated on the front side of the base offers several features. You can simply set the DMX address, master/slave mode, read the number of lamp or unit hours, run test, make a reset and also use many functions for setting and service purposes.

The main menu of the control panel is accessed by pressing the [**Mode**] button - press this one so many times until the display shows message "A001" (with actually stored address). Browse through the menu by the pressing [**Up**] or [**Down**] buttons - the display shows step by step these messages: **A001,SLCt, InFO,PErS,tESt, StAL,rESE, SPEC**. Press [**Enter**] if you wish to select one of them. The functions are described in the following sections and the function hierarchy is shown below.

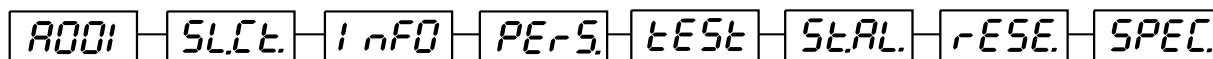

9.1 Addressing



By this menu you can set the DMX address or address the fixture as a master/slave.

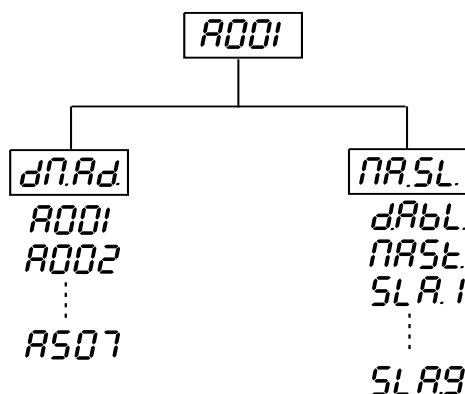

- DMX addressing

1. Press the [**Mode**]- button so many times until the display shows message "A001" (with actually stored address).
 2. Press [**Enter**]-button and use the [**Up**] and [**down**] buttons to select "dM.Ad."-menu.
 3. Press [**Enter**]-button (the letter "A" flashes) and by [**Up**] and [**down**] buttons select required address (001 - 507), press [**Enter**]-button to confirm.
 4. Select "MA.SL."-menu, press [**Enter**]-button and use [**Up**] and [**down**] buttons to select "d.AbL." (no master or slave), press [**Enter**] to confirm.
 5. Press the [**Mode**]- button. Chosen address is shown on the display.
- If message "A001" (with actually stored address) flashes - no DMX data received at the DMX-input.

- Master/slave addressing

1. Press the [**Mode**] button so many times until the display shows message "A001" (with actually stored address).
 2. Press [**Enter**]-button and use the [**Up**] and [**down**] buttons to select "MA.SL."-menu.
 3. Press [**Enter**]-button (display flashes) and select "MASt." (to set the fixture as the master in a chain of multiple fixtures) or "SLA.1" - "SLA.9" (to set the fixture to be the slave in a chain of multiple fixtures) and press [**Enter**] to confirm. If you want address no master or slave, select "d.AbL.".
 4. Press the [**Mode**]- button. Chosen address is shown on the display.
- If message "MASt." fast flashes - DMX signal is received at the DMX-input. Disconnect DMX controller!

Only one fixture may be the master. Up to the 9 slaves may be connected to the master and on the certain address can be connected only one slave fixture (SLA.1-SLA.9).

Note: Disconnect the fixtures from the DMX controller before master/slave operating, otherwise data collisions can occur and the fixtures will not work properly!

If the fixture is set as the master and DMX signal is connected to its input, the error message "MAEr" will appear on its display and the fixture's address will be set to its DMX address in order to respond to DMX signal from the controller.

For example:

The master fixture has this address setting: "dM.Ad."-menu.....**A013**

"MA.SL."-menu.....**MASt** (is displayed)

The DMX signal is connected to the master fixture. The message "**MASt**" starts fast flashing and after 20s error message "MA.Er" appears on its display and the fixture automatically will be switched to its DMX address (master address is disabled).

Now the fixture has the address setting: "dM.Ad."-menu.....**A013** ("A013"/" MA.Er"blinks)

"MA.SL."-menu.....**d.AbL.**

If the fixture is set as the slave and DMX signal is connected to its input, the fixture will respond to DMX signal from the controller (in dependence on the fixture's DMX address).

9.2 Slave control



This function allows you to control the slaves from the master's control panel in a master/slave operation.

Select this function from the main menu and press [**Enter**]-button. Browse the list of all connected slaves ("SL.C.1" - "SL.C.9") by pressing [**Up**] and [**Down**] buttons. Select the desired slave and press [**Enter**]-button. The slave's control panel is available from the master's control panel.

If no slave is connected to the master, messages "SL.C.1", "SL.C.2", "SL.C.3"... "SL.C.9" still round repeat.

Note: This function is available from the master fixture only.

9.3 Fixture informations



The menu allows you to read a useful information about the fixture as the lamp life, lamp strikes, software version, etc.

Press [**Up**] or [**Down**] buttons to select the desired option and press [**Enter**] to see the value or next submenu.

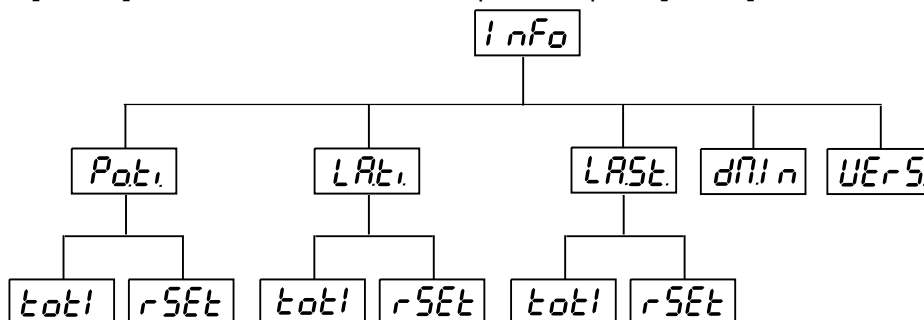

Power On time



-By this option you can read the total number of the operation hours since the ECOLOR 250 XT has been fabricated. Press [**Enter**] or [**Mode**] to return to the menu.

rSEt - The number of the hours that the ECOLOR 250 XT has been powered On since the counter was last reset. Press [**Enter**] or [**Mode**] to return to the menu. In order to reset this counter to 0, you have to hold the [**Up**] and [**Down**]-button and press the [**Enter**]-button.

LAt. **Lamp On time**

totl - This option enables you to read the total number of the operation hours with the lamp on since the ECOLOR 250 XT has been fabricated. Press [**Enter**] or [**Mode**] to return to the menu.

rSEt - The number of hours that the lamp has been powered On since the counter was last reset. Press [**Enter**] or [**Mode**] to return to the menu. In order to reset this counter to 0, you have to hold the [**Up**] and [**Down**]-button and press the [**Enter**]-button.

LASt. **Lamp strikes**

totl - By this option you can read the total number of the lamp strikes since the ECOLOR 250 XT has been fabricated. Press [**Enter**] or [**Mode**] to return to the menu.

rSEt - The number of the lamp strikes since the counter was last reset. Press [**Enter**] or [**Mode**] to return to the menu. In order to reset the counter to 0, you have to hold the [**Up**] and [**Down**]-button and press the [**Enter**]-button.

dm.n. - **DMX values**

Readout DMX values of each channel received by the fixture. Use the [**Up**] and [**Down**] buttons to select desired channel and press [**Enter**] to read its value coming to the fixture or [**Mode**] to cancel and return to the menu.

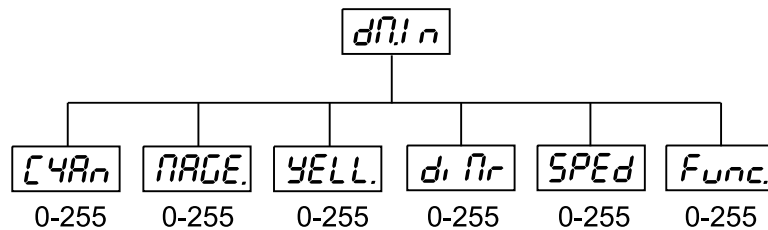

UEr.S. - **Software version**

By this function you can read the software version of the display module. Press [**Enter**] to read its value or [**Mode**] to return to the menu.

9.4 Personality options

PEr.S.

These options allow you to modify ECOLOR 250 XT operating behavior. Press [**Up**] or [**Down**] buttons to select the desired option and press [**Enter**] to set the value or to see next submenu.

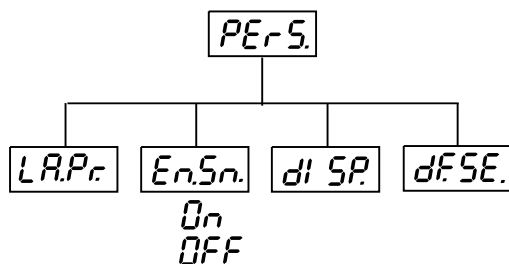

L.A.P.r.

Lamp presetting

This function allows you to adjust the lamp settings:

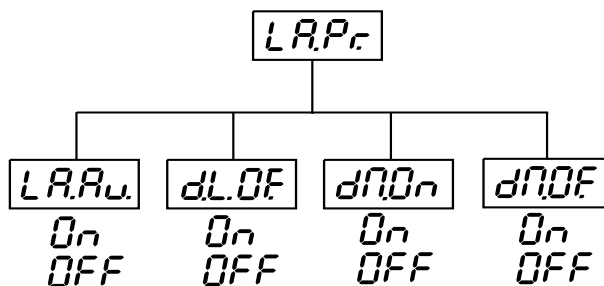

L.A.R.u.

Lamp On after switching the fixture On

This function enables to turn the lamp on automatically after switching the fixture on. Use the **[Up]** and **[Down]** buttons to select "On" if you wish to turn the lamp on automatically after switching the fixture on or "Off" if you wish the lamp off after switching on the fixture and press **[Enter]** to confirm or **[Mode]** to cancel and return to the menu.

dL.OF.

Lamp Off via DMX

This function allows you to switch off the lamp by DMX. Use the **[Up]** and **[Down]** buttons to select "On" if you want to switch off the lamp by DMX or "Off" if you don't want to switch off the lamp by DMX and press **[Enter]** to confirm or **[Mode]** to cancel and return to the menu.

dOnOn

Lamp On if DMX is present

This function allows you to strike the lamp automatically after 26 seconds if DMX signal is present on the data link. If the ignition is unsuccessful (e.g. lamp is too hot), the fixture will try to ignite the lamp after next 26 s. This process will repeat until the lamp lights. Use the **[Up]** and **[Down]** buttons to select "On" if you want to strike the lamp or "Off" if you don't want to strike the lamp and press **[Enter]** to confirm or **[Mode]** to cancel and return to the menu.

dOnOF.

Lamp Off if DMX is missing

This function allows you to switch Off the lamp automatically after 2 minutes if DMX signal is missing on the data link. Use the **[Up]** and **[Down]** buttons to select "On" if you want to switch Off the lamp or "Off" if you don't want to switch Off the lamp and press **[Enter]** to confirm or **[Mode]** to cancel and return to the menu.

En.S.n.

Switch On/Off the lamp light sensor

Use the **[Up]** and **[Down]** buttons to select "On" if you wish to switch the lamp light sensor on and press **[Enter]** to confirm or **[Mode]** to cancel and return to the menu. **The option "On" is for the standard operation.** Use the **[Up]** and **[Down]** buttons to select "Off" if you wish to switch the lamp light sensor Off and press **[Enter]** to confirm or **[Mode]** to cancel and return to the menu.

Important: The option "Off" is for "emergency operation" only if the lamp light sensor is defective and you will wait for a service intervertion! If the lamp light sensor is switched Off, the error messages

"**LAEr,SnEr,HEAt**" will not appear on the display (only the message "HEAt" will appear if the lamp was turned off and on within 5 minutes) and at switching the lamp on the electronics will still try to ignite the lamp until it shines (even when the lamp is damaged or absent), on this account some electronics parts could be damaged!

di SP. - Display adjusting

This function allows you to adjust the display settings:

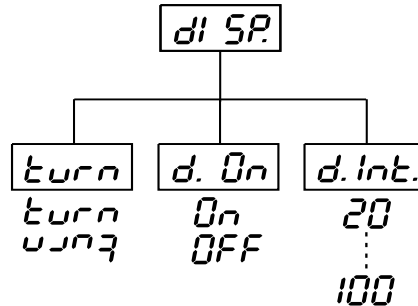

di. int. - Display -intensity

With this function you can adjust the display intensity from 20% to 100% . Use the **[Up]** or **[Down]** buttons to select the level of the display intensity and press **[Enter]** to confirm or **[Mode]** to cancel and return to the menu.

turn - Display-reverse

With this function, you can rotate the display by 180°. Use the **[Up]** or **[Down]** buttons to select "normal display" or "display turned by 180°" and press **[Enter]** to confirm or **[Mode]** to cancel and return to the menu.

d.On - Display-On

This function allows you to keep the display on or to turn off automatically 2 minutes after last pressing any button on the control panel. Use the **[Up]** or **[Down]** buttons to select "On" if you wish to keep the display on or "Off" if you wish to turn off automatically 2 minutes after last pressing any button on the control panel and press **[Enter]** to confirm or **[Mode]** to cancel and return to the menu.

- Default settings

Press [Enter] to reset all fixture personalities (not the adjusting functions) to the default values. On the display will appear "rSt" meaning that the fixture makes the reset. See the table of personality setting and their default positions.

Personality	Display	Default values (SHADED)
Lamp On after switch. the fixture On	LAAU	On
		OFF
Lamp Off via DMX	dLOF	On
		OFF
Lamp On if DMX is present	dNOOn	On
		OFF
Lamp Off if DMX is missing	dNOF	On
		OFF
Display-On	d On	On
		OFF
Display intensity	d Int	20 40 60 80 100
Display- reverse	turn	turn
		turn
Presetting playback	Auto	On
		OFF
Light level-start	On L	0-255
		0
Light level-stop	OFFL	0-255
		255
Timer 1-start	Ont1	0000-2359
		OFF
Timer 1-stop	OFt1	0000-2359
		OFF
Timer 2-start	Ont2	0000-2359
		OFF
Timer 2-stop	OFt2	0000-2359
		OFF
Switch On/Off the lamp light sensor	EnSn	On
		OFF

9.5 Switching On/Off the lamp



Press the [Mode] button in order to access the main menu. Browse through the menu by pressing the [Up] and [Down] buttons until the display shows "LAMP". Confirm by pressing [Enter] button. Use the [Up] and [Down] buttons to select "On" to switch On the lamp and "Off" to switch Off the lamp and press [Enter] to confirm or [Mode] to cancel.

9.6 Test sequences



This function allows you to run a special demo-test sequences without an external controller, which will show you

some possibilities of using ECOLOR 250 XT and is a good for an introduction of the fixture.
 Browse through the menu by pressing the **[Up]** and **[Down]** buttons until the display shows "tEst". Confirm by pressing **[Enter]** button in order to run the test program.
 If you want to pause the running program in the required position, press the **[Enter]**-button(messages "PAUS./test." blink). To continue the program running, press the **[Enter]**-button again.

9.7 Stand-alone setting



This menu offers options for stand-alone mode as a program playing ,programming and modifying current programs. You can run programs at pre-defined two periods during a 24 hour period or at a certain light level.

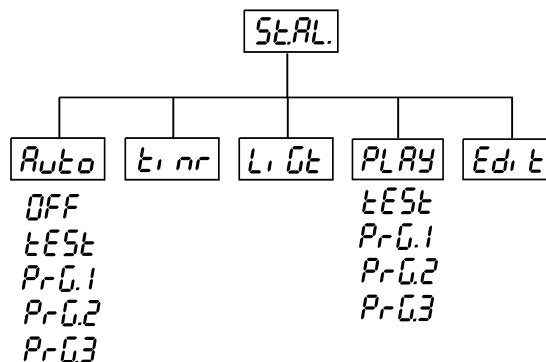

Auto -Presetting playback

This function allows you to select the program which will be played in the stand-alone mode after switching the fixture on(**LAAu**-function must be "On" in the menu **LAPr**). The selected program will be also used for the operating with the time periods or the light level period(**LAAu**-function must be "OFF" in the menu **LAPr**).
 Use the **[Up]** and **[Down]** buttons to select desired program ("tEst"- bilt-in program) or "OFF" if you don't want to trigger any program and press **[Enter]** to confirm or **[Mode]** to cancel and return to the menu. Selected program will be played continuously in a loop as long as it appears on the display.
 This option should be set "OFF" for all slaves in the master/slave chain by reason of the right program starts.
 For example: You have selected program "PrG.3" in this menu and:
 This fixture is set as a single fixture (master/slave or controller operating)- the fixture will run its program "PrG.3".
 This fixture is set as a master in a data chain- the fixture will run its program "PrG.3".
 This fixture is set as a slave in a data chain- the fixture will run its program according to the master(if the master runs its own program "PrG.1", the slave will run its own program "PrG.1"also).

Note for the controller mode: If the fixture operates in this mode (DMX controller is connected) and any program from this menu is selected ,the fixture will start to play the selected program if:
 - the fixture is switched on
 - the reset command from DMX controller is received
 - the timer or light level trigger are active and starts the operation
 In all these cases the fixture not respond to the DMX controller.

t, nr - Timer

By this menu you can set one or two periods during a 24 hour time period for the stand-alone operation. For example ,one period in the morning and one period in the evening.

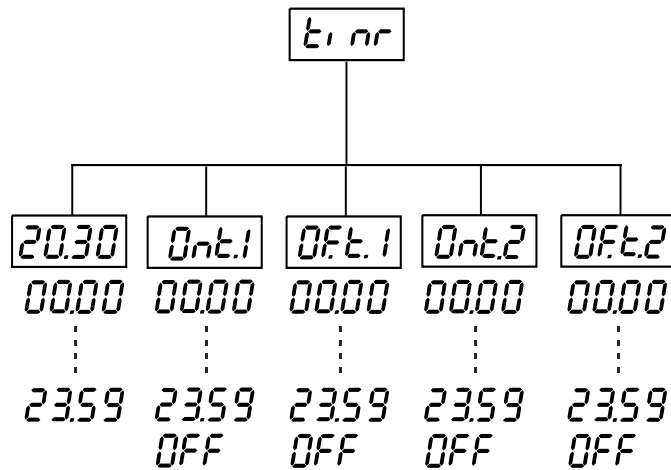

20:30 -Fixture clock

This function allows to set the current fixture time. Use the **[Up]** or **[Down]** buttons to set the hour and press the **[Enter]**-button. Use the **[Up]** or **[Down]** buttons to set the minutes and press the **[Enter]**-button to save the adjusted time or press the **[Mode]**-button twice to cancel and return to the menu.

Ont.1 -Timer 1 -start

This function sets the start of the time period 1. Use the **[Up]** or **[Down]** buttons to specify the start hour and press the **[Enter]**-button. Use the **[Up]** or **[Down]** buttons to specify the start minute and press **[Enter]**.

OFt.1 -Timer 1-stop

This function sets the finish of the time period 1. Use the **[Up]** or **[Down]** buttons to specify the stop hour and press the **[Enter]**-button. Use the **[Up]** or **[Down]** buttons to specify the stop minute and press **[Enter]**.

If you wish to deactivate the Timer 1, set Ont1="Off" and OFt1="Off".

Ont.2 -Timer 2 -start

This function sets the start of the time period 2. Use the **[Up]** or **[Down]** buttons to specify the start hour and press the **[Enter]**-button. Use the **[Up]** or **[Down]** buttons to specify the start minute and press **[Enter]**.

OFt.2 -Timer 2-stop

This function sets the finish of the time period 2. Use the **[Up]** or **[Down]** buttons to specify the stop hour and press the **[Enter]**-button. Use the **[Up]** or **[Down]** buttons to specify the stop minute and press **[Enter]**.

If you wish to deactivate the Timer 2, set Ont2 = "Off" and OFt2 = "Off".

Note: Please, be sure that you don't have any overlapping time periods to ensure the correct operation. Don't forget to choose the program which will be playing when the fixture operates (menu **Auto**).

If you want to modify the fixture clock or the time limits, do it when the program is not running, otherwise the current time period will not be finished correctly.

How to set the time period operation:

1. Set **LAAu**-function to "Off" (menu **PerS**, submenu **LAPr**).
2. Set the timer 1 and timer 2 (menu **StAL**, submenu **timr**).
If you will use only one time period for operations, deactivate the timer 2.
3. Choose the desired running program (menu **StAL**, submenu **Auto**).
4. Deactivate the light level trigger (menu **StAL**, submenu **LiGt**).

LiGt - Light level trigger

By this menu you can set a light level for the stand- alone operation.If the light intensity falls below the specified level then operation will start.

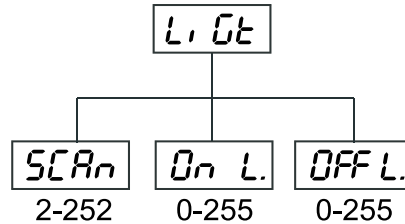

SCAn -Scanning the ambient light level

Press the **[Enter]** button to scan the current ambient light level (2-darkest,252-brightest).This value is useful as a comparative level for setting both start and stop light levels for operation in the stand-alone mode . The scanning takes about 7 seconds.By pressing the **[Mode]**- button you can return to the menu.

On L. -Light level - start

Use the **[Up]** and **[Down]** buttons to select the required light level when the operation is to be started(3-251) and press **[Enter]** to confirm or **[Mode]** to cancel and return to the menu.Don ´t forget to choose the program which will be playing when the fixture operates (menu "Auto").

Important:The values 0,1,2,252,253,254,255 do not affect the state of the fixture.

OFFL. -Light level -stop

Use the **[Up]** and **[Down]** buttons to select the required light level when the operation is to be finished (3-251) and press **[Enter]** to confirm or **[Mode]** to cancel and return to the menu.

Important:The values 0,1,2,252,253,254,255 do not affect the state of the fixture.

If you wish to deactivate the light level trigger,set the "OnL"= 0 and "OFFL"= 255.

Example of the light level operation:

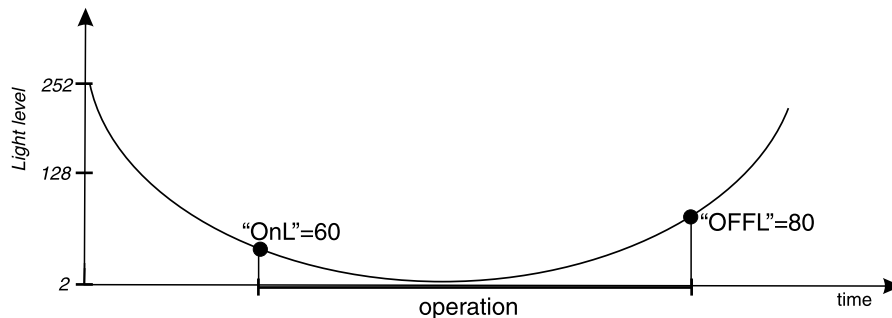

How to set the light level operation:

1. Set **LAAu**-function to "Off"(menu **PerS**,submenu **LAPr**) .
2. Set the start and stop light levels for fixture operating (menu **StAL**,submenu **LiGt**).
3. Choose the desired running program (menu **StAL**,submenu **Auto**).
4. Deactivate the timer 1 and timer 2 (menu **StAL**,submenu **timr**).

Note:The light sensor has the 2 minutes delay for the start/stop of the light level operation to eliminate the random light fluctuations.If the fixture is placed close to the changeable ambient illumination (e.g.neon signs),the time period for stand-alone operation may be useful than the light level setting.

- Playing program

This function allows you to run a built-in program "tEst" and the 3 freely-programmable programs "PrG.1,PrG.2,PrG.3". Press [Up] or [Down] buttons to select the desired program and press [Enter] to run the program which will be played continuously in a loop.

If you want to pause the running program in the required position, press the [Enter]-button (messages "PAUS"/"program No." blink). To continue the program running, press the [Enter]-button again.

Note: If the fixture operates in the controller mode (DMX controller is connected) and any program from this function is selected in this case the fixture will not respond to the DMX controller and will play selected program. You can't play programs on the slave fixtures from their control panels if the master fixture is switched On and connected to the slaves (playing is forced by the master).

- Editing program

This menu item allows you to select a program to edit or create. The ECOLOR 250 XT has one built-in program ("tEst") and the 3 free programs, each up to 99 steps. Each program step has a dynamic part (fade time) and static part (step time).

Fade time - the time, during which effects move to the programmed position.

Step time - the time, during which effects last in the current step.

If the fixture is set as a master, then you may edit any program in the slaves. You can't edit programs on the slave fixtures from their control panels if the master fixture is switched on and connected to the slaves (editing is possible by the master control panel only).

Procedure:

1. Press [Up] or [Down]-button to select the program you want to edit ("PrG.1" - "PrG.3") and press [Enter].
2. Press [Up] or [Down]-button to select the desired fixture ("MASt." - "SLA.9") and press [Enter]-button.
3. Press [Up] or [Down]-button to select the desired program step ("St.01" - "St.99") and press [Enter]-button.
4. Press [Up] or [Down]-button to select the desired item and press [Enter]-button. Now you can edit by [Up] or [Down] buttons the DMX value for selected item:

"P.End." - a total number of the program steps, value 1-99. **This value you must set before start programming** (e.g. if you want to create program with the 10 steps, set the value onto 10).

"CYAn" - a cyan, value 0-255

"MAGE" - a magenta, value 0-255

"YELL" - a yellow, value 0-255

"dimr" - a dimmer intensity, value 0-255

"SPEd" - a speed of CMY and dimmer, value 0-255

"Func" - a colour macros, switch On/Off the lamp, value 0-255

"S.tim." - a step time, value 0, 1-25, 5 seconds

"COPY." - a copying the current prog. step to the next prog. step. If the last prog. step is copied to the next prog. step, parameter "P.End" is increased about 1 automatically (except step 99).

5. Press [Enter]-button to confirm adjusted value.

6. Press [Mode]-button, select next prog. step and repeat this procedure (steps 4 and 6).

The editing programs "PrG.1,PrG.2,PrG.3" are saved in the current modified fixture (master or slave 1-9).

9.8 Reset function



Press [←] button to run a reset. This option enables the ECOLOR 250 XT to index all effects (functions) and return to their standard positions.

9.9 Special functions

SPEC.

Use the [Up] or [Down] buttons to browse through the special functions and select the one by pressing [Enter]-button.

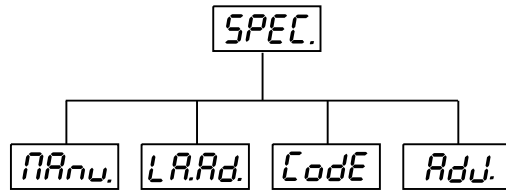

MANu. - Manual control of effects

The function allows you to control manually the channel functions of the fixture. Use the [Up] or [Down] buttons to select desired function and press [Enter] to adjust the effect or [Mode] to cancel and return to the menu.

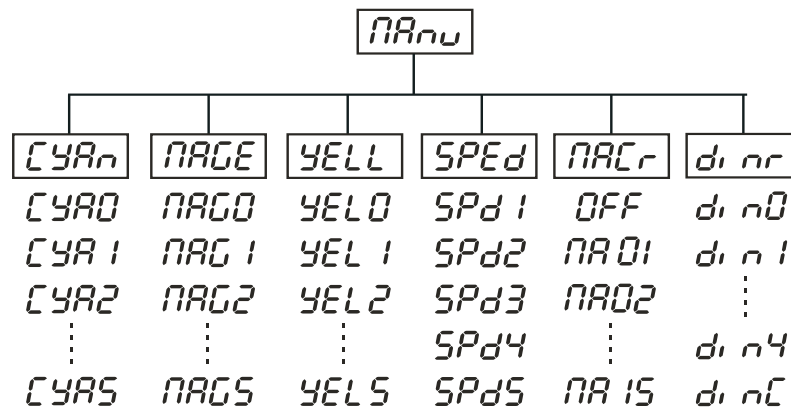

LAAd. - Lamp adjustment

This function can be used when you make the fine adjustment of the lamp. If you select "LAAd" pressing by [Enter]-button, all effects will be canceled, shutter will be opened and the dimmer intensity will be set onto 100%. By using the options "CYAn, MAGE, YELL, dimr" you can focus the light on a flat surface (wall) and perform the fine lamp adjustment.

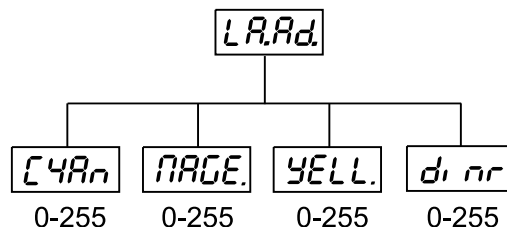

Code - Fixture code

The option contains identification code (1-9999) for the fixture, which is used for the master/slave operation.



- Adjusting the default positions of the CMY wheels

By this function you can adjust the colour wheels and the dimmer unit to their right positions. Use the **[Up]** and **[Down]** buttons to browse through the adjusting menu - the display shows step by step these messages: "**CYAn, MAGE, YELL, dimr**" by which you can adjust the effects to the required positions (0-255) before the function calibration. Then when the positioning is finished use the last "**FCAL**" function (Fixture calibration).

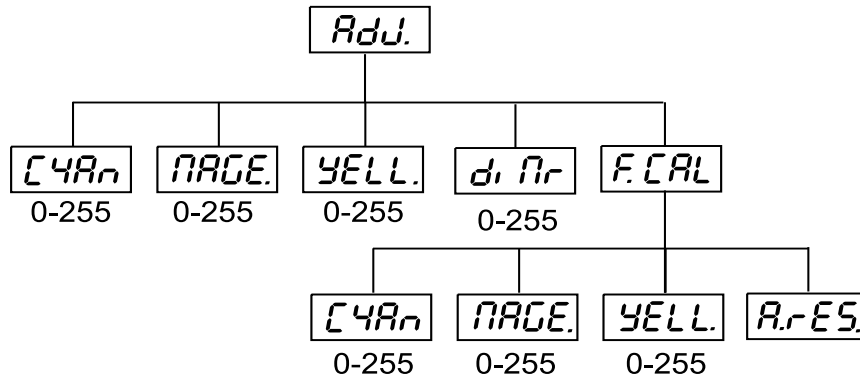

1. Calibration via the control board

Press **[Enter]** and the **[Up]** and **[Down]** buttons in order to display the following messages: "**CYAn, MAGE, YELL,**" for very smooth function calibration. Select one of them, press **[Enter]** and use the **[Up]** and **[Down]** buttons in order to adjust their right value from 0 to 255. Then press **[Enter]** to confirm or **[Mode]** to cancel and return to the menu. This can be repeated for each calibration parameter if it is required. When the calibration is finished, it is necessary to use the "**A.rES.**" function in order to write the calibration values to the memory (EPROM) and to make a reset in order to check the newly adjusted positions of the CMY-colours. When the reset of the fixture is finished, the display will show the "**F.CAL.**" message. Press **[Enter]** to repeat the calibration or **[Mode]** to return to the "**Adj.**" menu.

2. Calibration via the external controller

Connect the DMX controller to the fixture. Press **[Enter]** and the **[Up]** and **[Down]** buttons in order to display the following messages: "**CYAn, MAGE, YELL**" - calibration parameters. Select one of them and press **[Enter]**. Now you can calibrate the CMY-colours by your controller. The DMX calibration protocol is described in the table mentioned below.

DMX Calibration protocol:

DMX Channel	1	2	3	4	5	6
Function	CYAN	MAGENTA	YELLOW	DIMR	SPEED CMY,DIM.	COL. MACROS
	CALIBRATION 0-255	CALIBRATION 0-255	CALIBRATION 0-255	STANDARD PROTOCOL	STANDARD PROTOCOL	STANDARD PROTOCOL
	SMOOTH MICROSTEP MOVEMENT					

After having calibrated required functions press **[Enter]** to confirm (or **[Mode]** to cancel and return to the menu without reset by the "**A.rES.**" function) and use the "**A.rES.**" function in order to write the calibration values to the memory (EEPROM) and to make a reset in order to check the new adjusted positions of the CMY-colours .

10. Error and information messages

HEAt

This message appears if you try to switch on the lamp within 5 minutes after having switched it off (the lamp is too hot). The message will appear on the display if the lamp doesn't ignite within 15 seconds. The ECOLOR 250 XT will store this information and automatically ignite the lamp when the 5 minutes period has expired.

Caution: The message is disabled if the lamp light sensor (function "En.Sn.") is switched Off (only if the lamp was turned Off and On within 5 minutes, the message "HEAt" will appear).

LA.Er.

The ignition of the lamp is seven times unsuccessful (the HEAt message appeared six times before), and the display shows "LA.Er.", meaning that the lamp could be damaged or even missed, the fixture is overheating (this can occur if the ambient temperature is 45° C or more) or there could be a failure on the ignitor or ballast.

Please place or replace the lamp, check the ambient temperature or contact your dealer if the situation was not caused by the lamp.

Caution: The message is disabled if the lamp light sensor (function "En.Sn.") is switched Off.

SnEr.

This message appears if the lamp lighting sensor is failed. Please, contact your dealer.

Caution: The message is disabled if the lamp light sensor (function "En.Sn.") is switched Off.

MA.Er

(Master error) The message informs you that the fixture was addressed as a master and DMX signal is connected to its input. Disconnect the DMX controller from fixture's input and address the fixture as the master again. The message appears after switching the fixture Off and On.

Po.Er.

This message will appear if the fixture was shortly disconnect from the main.

Fr.Er.

It will appear if the frequency of the mains is not standard 50 or 60Hz.

11. Technical specifications

Power supply:

EU-model:	208/230/240V AC, 50/60Hz ~
Fuse:	T 3.15A @ 230V
US-model:	100/120/208/230/240 V AC, 50/60Hz ~
Fuse:	T 6,3A @ 120V
Power consumption:	450 VA

Remote control:

2 batteries 1,5V ,size AAA,LR03(T)

Lamp:

MSD/HSD 250 GY-9,5

Optical System:

- 150mm Fresnel lens
- Manually adjustable zoom 8 - 22°
- High reflectivity computer designed elliptical reflector for maximum lighting output

Colours:

-CMY - colours mixing system

Effects:

- 15 colour macros
- Horizontal beam shaper – manually adjustable
- Vertical beam shaper – manually adjustable
- Frost filter for softer/wide beam – manually adjustable
- Colour temperature correction filter 3200K – manually adjustable

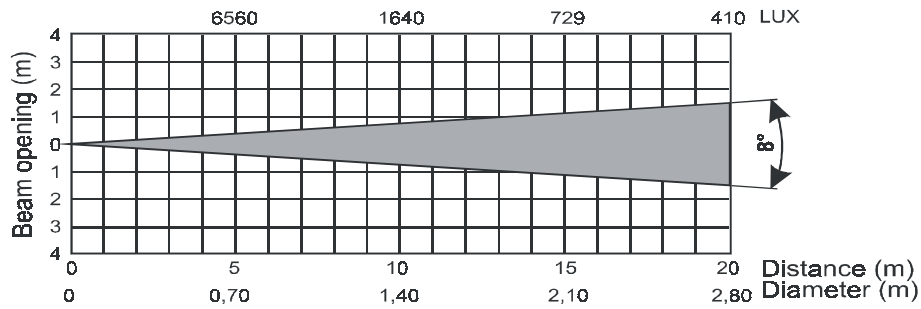
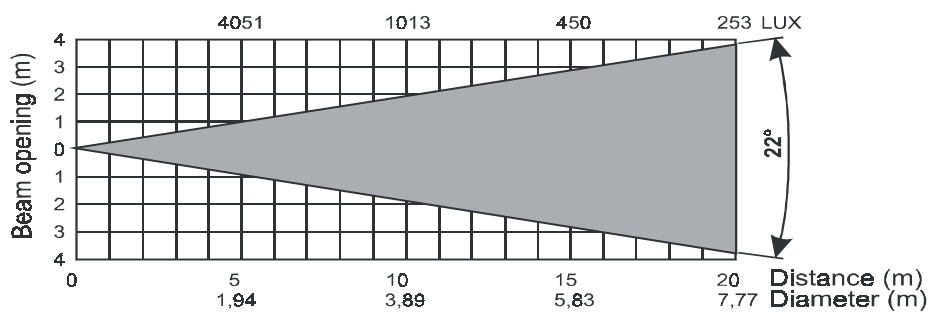
Beampath:**Min. beam angle 8°****Max. beam angle 22°****Dimmer:**

- Smooth dimmer from 0 - 100 %

Fan:

- Axial fan in the fixture head

Motor:

- 4 high-quality stepping motors controlled by microprocessors

Electronics:

- Digital serial input DMX-512
- 6 control-channels (8 bit protocol):
 - Channel 1: Cyan
 - Channel 2: Magenta
 - Channel 3: Yellow
 - Channel 4: Dimmer intensity
 - Channel 5: Speed of CMY and dimmer
 - Channel 6: Colour macros, Switching On/Off the lamp

Rigging:

- Mounts horizontally or vertically with 2 crews
- Vertical head adjusting range: 130°
- Protection factor IP 65

Temperatures:

Maximum ambient temperature t_a : 35° C

Maximum housing temperature t_b (steady state): 110° C

Minimum distances:

Min.distance from flammable surfaces: 1,0m

Min.distance to lighted object: 1,0m

Dimensions and weight:

Length : 330 mm

Width: 295 mm

Height (head horizontally): 450 mm

Weight (net): 22 kg

Shipping weight: 28 kg

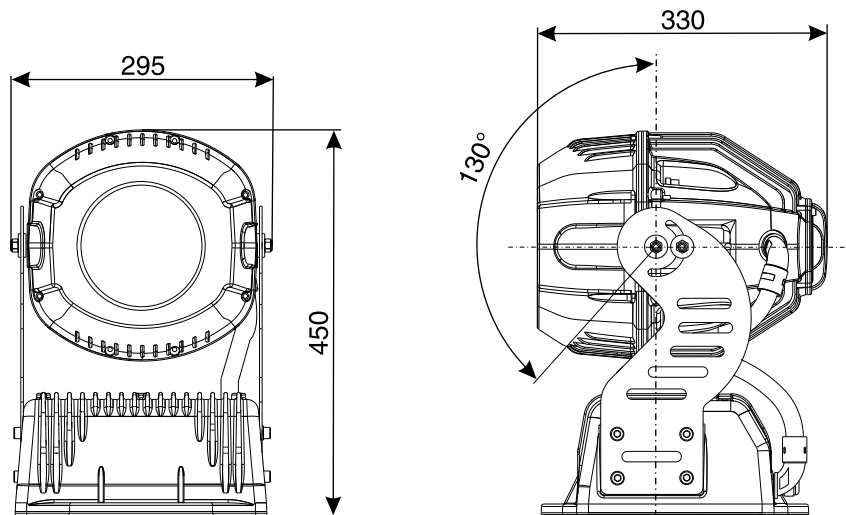

12. Maintenance and cleaning

The operator has to make sure that safety-relating and machine-technical installations are inspected by an expert after every four years in the course of an acceptance test.

The operator has to make sure that safety-relating and machine-technical installations are inspected by a skilled person once a year.

The following points have to be considered during the inspection:

- 1) All screws used for installing the devices or parts of the device have to be tightly connected and must not be corroded.
- 2) There must not be any deformations on housings, fixations and installation spots (ceiling, suspension, trussing).
- 3) Mechanically moved parts like axles, eyes and others must not show any traces of wearing (e.g. material abrading or damages) and must not rotate with unbalances.
- 4) The electric power supply cables must not show any damages, material fatigue (e.g. porous cables) or sediments. Further instructions depending on the installation spot and usage have to be adhered by a skilled installer and any safety problems have to be removed.

DANGER TO LIFE !
Disconnect from the mains before starting
maintenance operation!

Regular cleaning will not only ensure the maximum light-output, but will also allow the fixture to function reliably throughout its life.

Rinse off loose dirt with a garden hose or low pressure water spray. Wash the housing with a soft brush or sponge and a mild, non-abrasive washing detergent. Rinse it.

There are no serviceable parts inside the device except for the lamp and the batteries inside the remote control. Maintenance and service operations are only to be carried out by authorized dealers.

Please refer to the instructions under "Fitting/Exchanging the lamp".

Should you need any spare parts, please use genuine parts.

If the power supply cable of this device will be damaged (cable firmly connected with the device), it has to be replaced by authorized dealers only in order to avoid hazards.

If the power supply cable of this device will be damaged (replaceable cable), it has to be replaced by a special power supply cable available at your dealer.

Should you have further questions, please contact your dealer.

Replacing the main fuse

The fixture contains 3 fuses located on the circuit board. The main fuse is placed in the fuseholder next to the relay on the circuit board and has marking F10 (see the picture below). If the lamp burns out, the fine-wire fuse of the device might fuse, too. Only replace the fuse by a fuse of the same type and rating.

Before replacing the fuse, unplug mains lead!

The fuse replacement should be carried out by authorized persons only.

Procedure:

Step 1: Open the plate cover of the base by loosening the 12 screws and remove the rubber seal.

Step 2: Remove the old fuse from the fuseholder.

Step 3: Install the new fuse in the fuseholder.

Step 4: Reinsert the seal and the plate cover of the base and tighten the screws.

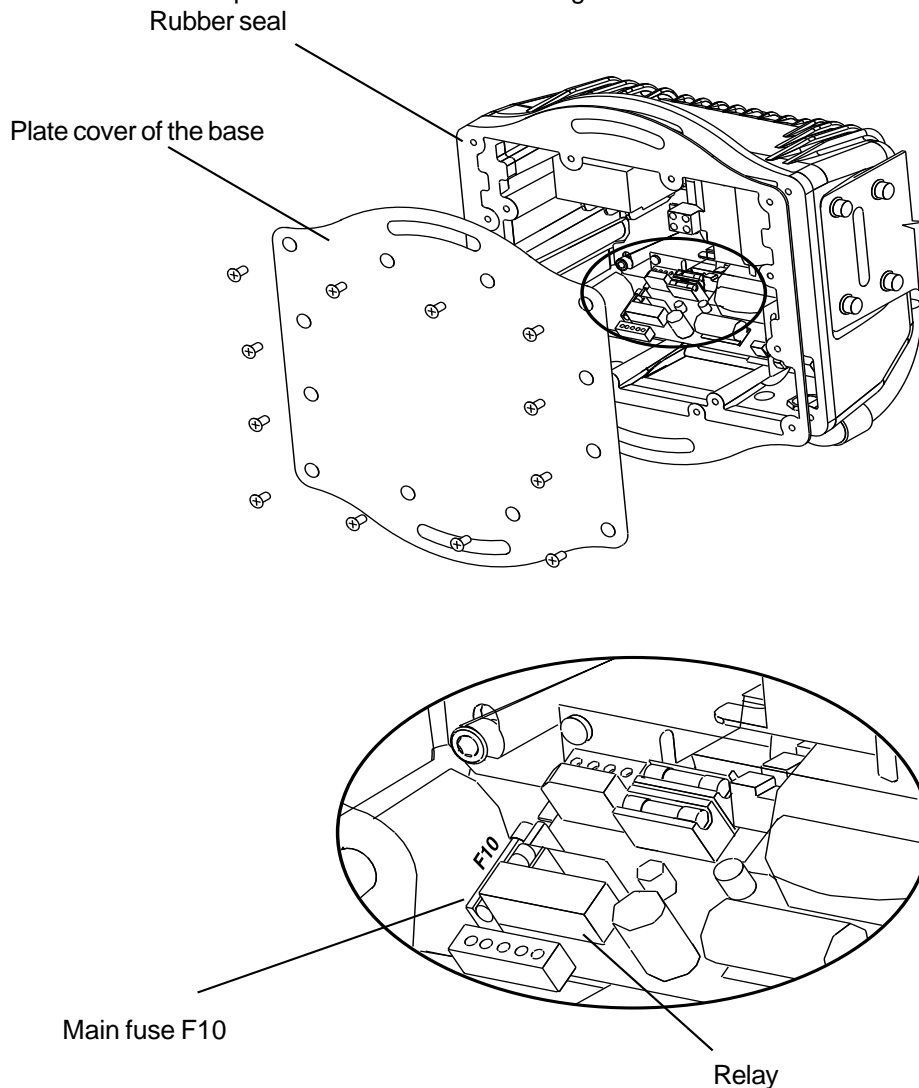

Replacing the batteries in the remote control

Pull off the bottom cover of the remote control and take the batteries out. Replace the exhausted batteries with a new ones-check the voltage and the polarity! Push the bottom cover in back.

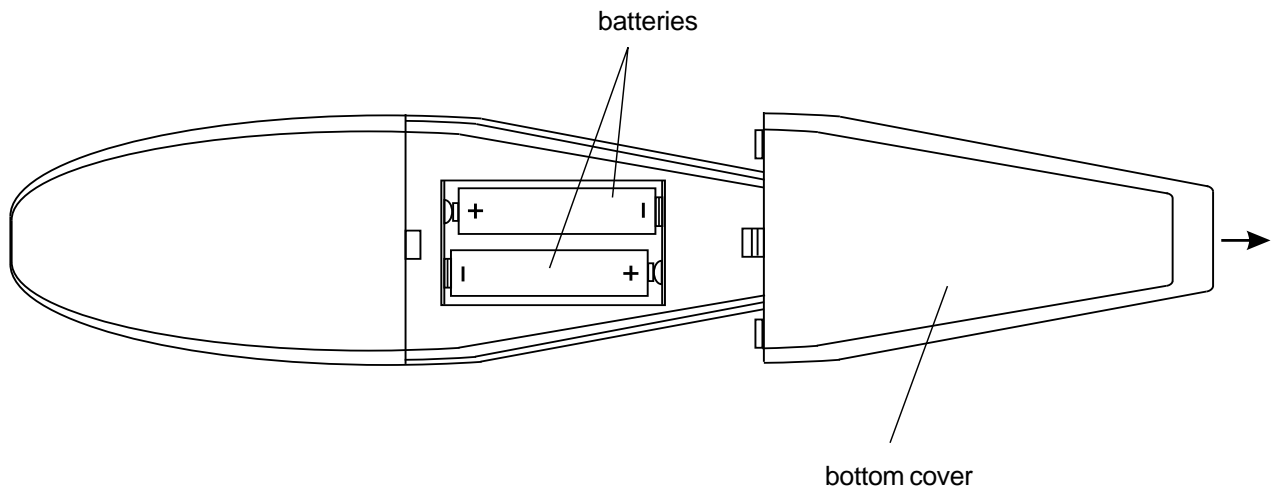

13. Appendix

We hope you will enjoy your ECOLOR 250 XT. We can assure you that you will enjoy this device for years if you follow the instructions given in this manual.

Should you have further questions, do not hesitate to contact us.

Please note: Every information is subject to change without prior notice.

Version 1.0