

OWNER'S MANUAL

US

VS

Seat system for Power Wheelchair



Table of Contents

Important information about user manual	6
Technical support.....	7
Spare parts and accessories.....	7
Disposal.....	7
Guarantee and service.....	7
Product approval.....	7
Safety rules and regulations	8-17
General introduction	18
Design & Function.....	19
Operation.....	24
Settings and adjustment.....	29
Arm rest.....	29
Chest support.....	29
Head rest.....	30
Trunk support.....	31
Lumbar support.....	31
Foot plate.....	32
Knee support.....	34
Angle gauge.....	34
Positioning belt.....	35
Control panel.....	36
Care and maintenance.....	38
Transport.....	39
Technical specifications.....	41

Important information about user manual

Congratulations on your choice of Permobil product. We will do all in our power to ensure your continued satisfaction with our product.

Before you start using your seat and wheelchair, it is important to read and understand the contents of this user manual and especially the section on Safety. The user manual is primarily designed to inform you about the functions and capabilities of your seat and to advise you on the best way of using it. It also contains important safety and maintenance information and describes some of the problems which might arise in use.

Always keep the user manual on or near your wheelchair as you may need to consult its important information on use, safety and maintenance.

You can also find information on our products on our website. You will find us on www.permobil.se.

If your seat bears a sticker with the words "Customized product", it has been adapted to your needs and requests. This means that design and functions may differ from the text of this user manual, or from the design and functions of other seats of the same type.

All information and all photographs, illustrations and specifications are based on the product information that was available at the time this user manual was printed. Photographs and illustrations that appear in the user manual are typical examples and not intended to be exact depictions of different parts of the seat.

We reserve the right to make changes to the product without prior notification.

TECHNICAL SUPPORT

In the event of technical problems, you should contact your dealer

Always state the chassis serial number when contacting Permobil to ensure that the correct information is provided.

SPARE PARTS & ACCESSORIES

Spare parts and accessories must be ordered through your dealer.

SCRAPPING THE WHEELCHAIR

Contact Permobil Inc. for information about scrapping agreements in force.

WARRANTY

A warranty registration card is attached to each new wheelchair. The Permobil Inc. Product Warranty Information sets forth the conditions of the warranty.

Contact your dealer or Permobil Inc USA for information about the warranty period for this wheelchair.

Safety Instructions - General

The seat is heavy and contains many moving parts. Special care must therefore be taken when it is used. Please read and follow all instructions and warnings in this manual before operating your seat together with your Permobil powered wheelchair. Incorrect use may both injure the user and damage the seat and wheelchair. In order to reduce these risks, you should read the Owner's Manual carefully, in particular the safety instructions and their warning texts.

Throughout this manual the following symbol will be used to note items that have significant importance to safety concerns:



NOTE

Please use caution where this symbol appears.



WARNING

Please use extreme caution where this warning symbol appears. Failure to observe warnings can lead to personal injury and property damage, including damage to the wheelchair.

Permobil is not responsible for personal injuries or property damage resulting from any person's failure to follow the warnings and instructions in this manual. Permobil is not responsible for injuries or damage resulting from failure to exercise good judgment.

The final selection and purchasing decision about the type of electric wheelchair and seating system to be used is the responsibility of the wheelchair user and his or her healthcare professional. Permobil Inc. is not responsible for inappropriate selections of wheelchair models and seating system or features or improper fitting of the wheelchair and seat.

Safety Instructions - General

Your wheelchair and seat was configured specifically for your needs as prescribed by your healthcare provider. Consult your healthcare provider before changing the seat position or making any other adjustment. Some adjustments may reduce your wheelchair's performance or safety or may not be appropriate for your needs.

It is also of the utmost importance that you devote sufficient time to become acquainted with the different buttons, the function and steering controls, the different adjustment possibilities of the seat, etc. of your wheelchair and its accessories before you begin using it.

Do not undertake your own first test drive without making sure that you have assistance in the immediate vicinity if you should need help.

In order to make sure that nothing happened to the wheelchair while it was being shipped to you, you should check the following items before beginning to use it:

- that all products ordered are included in the delivery, including operating instructions and possible other documentation. If you suspect that something is missing, then contact your supplier or Permobil for more information as soon as possible.
- that no transport-related or other damages have occurred to the wheelchair, seat and its accessories. If you discover that something has been damaged or in some other manner appears to be incorrect, then contact your supplier or Permobil for more information as soon as possible before you continue the checks.

Safety rules



WARNING

Before taking the seat into use for the first time and after adjustments or other changes to the seat have been made, the following safety checks must always be carried out.

- Check that all supports, for example the chest roller and knee stop, are mounted before starting to use the chair.
- Check that all tapes on the seat are intact and correctly mounted.



WARNING

After adjustment and other actions the following safety checks must be carried out.

1. Check that the bolts on all actuators and articulated rod heads, see photo, have been properly tightened.
2. Check that the stop chain is fitted to the leg rest, see photo. The screws holding the chain must be screwed tight.
3. Check that the locking screws (1) for height adjustment on the foot plate are tightened, see Fig. 3. Check that the two locking nuts (2) for angle adjustment on the rear of the foot plate are tightened, see Fig. 3.
4. Check that the screws (4 pcs.) for the arm rest stop are properly tightened on both sides of the seat.

Safety rules



Articulated rod head.



Leg rest stop chain.

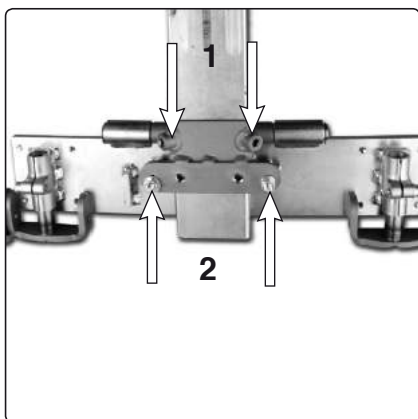

Leg rest with foot plate seen from behind.



Arm rest stop.

Safety rules



WARNING

Risk of crushing

Note that the seat is heavy and contains many moving parts, which means there will always be some risk of crushing.

Use the seat's electric seat functions with the greatest care. Above all: when you have moved up to or under a table or other fixed or moveable object, always make sure there are no items in the immediate vicinity which could interfere with the seat's moving parts.

Operation of seat lift

Make sure that nothing can get in between the chassis and the seat when the seat lift is being used. Using the seat lift alters the center of gravity, which always means an increased tipping risk. Always travel at low speeds and only use this seat function on a level surface and not on slopes, ramps, hills or other gradients.

Center of gravity

Note that the following factors may affect the center of gravity of the seat/wheelchair and thus the tipping risk:

- Raising the seat lift
- Height and angle of seat
- Position or weight distribution of the body
- Travel on sloping surfaces, e.g. ramp or hill
- When wearing a rucksack or other items, depending on the extra weight.

Elevation to standing position

Elevation to standing position and operation in standing position must only be done on a flat surface. When the chair is in elevated position, never reach out from the chair, due the higher tipping risk.

If your wheelchair starts to move in an unexpected way, immediately let go of the joystick to stop the wheelchair. Except in an emergency, never use the off/on button to stop the wheelchair. This could lead to the wheelchair stopping quickly and violently and could lead to personal injury.

Safety rules



WARNING

Positioning Belts

Always wear your positioning belt while in your wheelchair. If signs of damage or wear appear, replace the positioning belt immediately through your Permobil dealer.

Transfer into and out of the chair

Be sure that the power is turned OFF before entering or leaving the wheelchair and before lifting the control side armrest.

When transferring into or out of the wheelchair, every precaution should be taken to reduce the distance between the wheelchair and the place to which the user is transferring. Overextending this distance can cause user to overexert, lose balance, or fall.

Permobil recommends that users transfer in the presence of or with the assistance of an attendant.

Use caution when bending or reaching.

Never use the joystick as a handhold or point of support.

Do not use foot plates or armrests as supports when transferring into or out of the wheelchair. The footplates and armrests are not designed to be weight-bearing structures. Excessive force may cause them to give way, resulting in personal injury or property damage, including damage to the wheelchair.

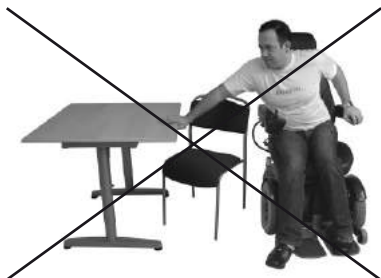

Safety rules



WARNING

Passengers

The seat is not designed for transporting passengers, whatever their age. Nor is it designed for taking heavy items other than the user's personal belongings. The indicated maximum user weight given in this manual must not be exceeded. Ignoring this could impair the wheelchair's maneuverability and stability.

Use in different climates

Permobil's seats are designed to tolerate most weather conditions, but you should avoid exposing the seat to severe cold, persistent dampness, heavy rain/snowfall and similar situations. If the seat is exposed to any of these, do not use it again before it has completely dried out.

Remember also that certain surfaces on the seat may heat up or cool down under lengthy exposure to strong sunshine or cold etc.

If any of the seat enclosures or the control panel case show signs of cracking etc., they should be replaced so no moisture can penetrate and damage the electronics.

Safety rules



WARNING

Transport

The wheelchair/seat must be transported in or with transport solutions that have been approved for this purpose.

Do not lift or move the wheelchair/seat by any of its removable parts. Doing so could lead to personal injury and property damage, including damage to the seat and wheelchair.

Check that the wheelchair is properly secured and that the wheel locks are not disengaged. The wheelchair can be locked into position by running fastening straps through the brackets at the front and back. Also check that the fastening points on the transport vehicle are well-anchored.

A defectively fastened chair can cause serious injury to persons in the vehicle and serious damage to the vehicle.

Use Prohibited in Motor Vehicles

Permobil recommends that users NOT be transported in any kind of vehicle while in their wheelchair, unless the user is in an approved Permobil wheelchair configuration, has secured the wheelchair using a Permolock C, and is using a seat belt attached to the vehicle. The only other safe alternative is that users be transferred into factory vehicle seating for transportation and use safety restraints made available by the auto industry. The only wheelchair transportation system Permobil recommends is a Permolock C used in combination with an approved Permobil wheelchair.

Unless using a Permolock C with an approved Permobil wheelchair, never sit in your wheelchair while in a moving vehicle. In an accident or sudden stop, you may be thrown from the chair and seriously injured or killed.

Permobil positioning belts are designed to position the user only and not to protect you in the event of a motor vehicle accident. The positioning belts do not replace use of a vehicle mounted restraint.

Safety rules



WARNING

Maintenance and service

Carry out only the service and maintenance activities noted in this user manual. All other servicing, alterations and changes to the seat and its accessories must be carried out by a competent servicing engineer or person with sufficient knowledge to give a competent result. In case of doubt always contact a competent servicing engineer or Permobil.

The power supply must always be interrupted for all work or servicing on the seat's electrical system. Read more on how you can do this in your wheelchair user instructions (chassis manual).

Use only spare parts or accessories approved or recommended by Permobil. All other use could lead to changes which might impair the function and safety of the seat. It could also lead to the guarantee on your seat becoming invalid.

Note that the seat is heavy and contains many moving parts, which means there will always be some risk of crushing.

Safety rules



WARNING

Storage

Never store the seat and its accessories in areas subject to condensation (vapor or moisture on surfaces), e.g. utility rooms or similar.

If you are unsure how best to store the wheelchair, contact your supplier or Permobil for information.

Damage/breakdowns to the seat and its accessories

If you start noticing that the seat and its various functions are not behaving as expected, or if you suspect anything is wrong, stop your test drive as soon as possible, turn off the wheelchair and contact your aid center or Permobil for information.

It is most important that Permobil is informed that the chair and its accessories have been damaged during transport, during driving or for some other reason as soon as possible after the damage has occurred. There could be a risk that the seat and its accessories can no longer be operated safely and without danger.

General introduction

The VS seat is designed to give wheelchair users extra freedom of movement, but it can also be used as a rehabilitation aid. The seat is controlled from the control panels for the wheelchair and seat. If the seat has the standing operation function, the chair may be operated at reduced speed with the seat in the standing position.



WARNING

Elevation to standing position must only be done on flat surfaces. When the chair is in elevated position, never reach out from the chair, due the higher tipping risk.



WARNING

Travel in standing position must only be done on flat surfaces.

Design and function

General

The seat consists of a seat frame with seat and back rest, arm rest and leg rest. To facilitate use of the elevation function it is also fitted with knee, calf and chest supports.

The photo shows the seat detached from the chassis.



- | | |
|--------------------------|------------------|
| 1. Head Rest (accessory) | 5. Knee support |
| 2. Control panel | 6. Foot plate |
| 3. Trunk support | 7. Back cushion |
| 4. Seat cushion | 8. Chest support |
| | 9. Arm rest |

Design and function

Control panel

The seat's electrical functions are controlled from the control panel. The control system may be in the form of conventional push buttons or may have toggle switches for those users who find these easier to maneuver. The toggle switch is moved forward to operate the front button and back to operate the rear button. The functions of the control panel are here described when fitted with conventional push buttons, but the functions are the same whatever the design of the control system.

Each control switch can have two functions, and the symbol for the active function will light up. Functions are changed using the **shift** function, see adjoining page.



NOTE

The number of available functions will vary depending on how your wheelchair and seat are equipped.



Seat control panel.

Design and function

The symbols on the control panel indicate what seat functions are available, what seat functions are restricted and what seat functions will cause speed reduction or stop motion completely. The symbols may be unlit, show a continuous light or flash.

Unlit symbol

The symbol for the function is unlit. This means that the function is not currently available. Use the “shift” button to switch between left and right seat function on the control switch.

Illuminated symbol

A constantly illuminated symbol gives information relating to operating speed. A constant *green* light means that the wheelchair can be operated at maximum speed.

A constant *yellow* light means that the maximum speed for the wheelchair is restricted due to the current position of the seat function.

A constant *red* light means that the wheelchair cannot be used for travel, due to the current position of the seat function.

Flashing symbol

A flashing symbol gives information relating to the actuators. A flashing green symbol means a special function, e.g. the memory function.

A flashing yellow symbol means that the function is barred in one direction due to a safety switch. The control switch for the current function will only work in the “safe” direction.

A flashing red symbol means that a fault in the current actuator has been detected. This may mean that the seat function will not work. Contact service.

Design and function

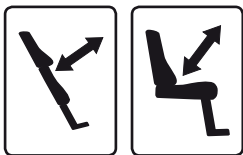

Standing

The seat rises to standing position when the toggle switch is moved forward and lowers to sitting when the switch is moved back.

The standing function can be configured to suit each user by pre-programming one of the three possible standing sequences. The symbol on the left shows the standing sequence which starts by straightening the user's hips and legs before raising them to a standing position. This sequence minimises pressure on the user's knees.

The symbol on the right shows the standing sequence which raises the user directly from a sitting position.



Seat lift

The seat rises when the toggle switch is moved forward and lowers when the switch is moved back.



Back rest angle

The back rest will slope back when the toggle switch is moved backwards and forwards when it is moved forwards.

Design and function



Leg rest angle

The leg rest moves out when the toggle switch is moved forwards and in when the toggle switch is moved back.



Seat angle

The seat will slope back when the toggle switch is moved backwards and forwards when it is moved forwards.



Shift

Change the control button function by moving the **shift** function toggle switch forwards. Change back by moving the **shift** function toggle switch forwards again. The symbols for the active functions will light up.



Memory function

The control panel has an integral memory with three memory positions. Each memory position can store all the seat's electrical settings.

Operation

General

The seat functions are controlled from the seat's control panel. The control panel's appearance varies according to the functions with which the chair is equipped. See two examples below: A standard panel and a panel for a seat equipped with **shift** and **memory** functions.

The shift toggle is used when a toggle switch has two function capability. The active function is changed by pressing the shift toggle first. The memory function can save up to three favourite seating positions which can easily be retrieved regardless of the seats current position.

The main switch on the wheelchair must be turned on before the seat's control panel will work. For information on the wheelchair control panel, see the Chassis User Manual.



Control panel "standard".



Exemple on Control panel with shift- and memoryfunction.

Operation

Shift

Change the control button function by moving the **shift** function toggle switch forwards. Change back by moving the **shift** function toggle switch forwards again. The symbols for the active functions will light up.



Shift function.

Standing

The seat rises to standing position when the toggle switch is moved forward and lowers to sitting when the switch is moved back.

The standing function can be configured to suit each user by pre-programming one of the three possible standing sequences. The picture sequence below shows the standing sequence which starts by straightening the user's hips and legs before raising them to a standing position. This sequence minimises pressure on the user's knees.



Standing function.

The **standard** control panel does not feature a toggle switch for the standing function. On such models standing is activated by the Leverman function in the joystick panel. Please see the section on Leverman in the relevant chassis' owner's manual.



Movement of seat to/from standing position with a standing sequence that minimises pressure on the user's knees.

Seat lift

This function adjusts the seat height. Moving the toggle switch forward raises the seat. Moving the toggle switch backwards lowers the seat again.



Seat lift.



Movement of seat during adjustment of seat height.

Back rest angle

This function adjusts the back rest angle. Moving the toggle switch backwards makes the back rest slope backwards, and moving the toggle switch forwards makes the back rest move forwards.

Certain seats may have a more limited back rest angle due to high user weight.



Back rest angle.



Movement of seat during adjustment of back rest angle.

Leg rest angle

This function adjusts the leg rest angle. Moving the toggle switch forwards angles the leg rests forward. Moving the toggle switch backwards angles the leg rests backwards.



Leg rest angle.



Movement of leg rests during adjustment of leg rest angle.

Seat angle (option)

This function adjusts the seat angle. For this function to work the seat must be in sitting or recumbent position. Moving the toggle switch backwards angles the seat backwards. Moving the toggle switch forward angles the seat forwards again.



Seat angle.



Movement of seat during adjustment of seat angle.

Memory function

The control panel has an integral memory with three memory positions. Each memory position can store all the seat's electrical settings.

Storing memory

Before storing a seating position in memory, position the seating system in the position that is desired to be stored.

- Enter the memory mode by pressing and holding the memory button (8) for two seconds, see illustration below. While in the memory mode, the LED flashes green.
- Activate the memory storage function by holding down button 4 for two seconds. The symbol above will light up green, which means that the function has been activated.
- Press and hold the desired "store" button (5, 6 or 7) for three seconds to memorize the current seat position in a memory location, see illustration below. The LED above the memory position will light red and the control panel will emit a tone when the memory has been successfully stored.
- Return to standard seat function operating mode by pressing the memory button (8), see illustration below.

Recalling memory

- Enter the memory mode by pressing and holding the memory button (8) for two seconds, see illustration. While in the memory mode, the LED flashes green.
- Press and hold the desired "recall" button (1, 2 or 3) to move the seating system to the desired memory position, see illustration. Releasing the "Recall" button stops actuator movement, as a safety feature.
- Actuator movement stops, the LED above the memory position lights green and the control panel emits a tone, when the "stored" position is reached.
- Return to standard seat function operating mode by pressing the memory button (8), see illustration.



Control panel memory function

Settings and adjustment

Arm rest

1. Unscrew the two nuts on the inside of the arm rest, see photo.
2. Adjust the arm rest for height and angle.
3. Tighten the two nuts.

Chest support - Depth adjustment

1. Unscrew the two nuts on the inside of the arm rest, see photo.
2. Move the fixing on the chest support until it reaches a suitable depth. The depth can be adjusted at intervals of 1".
3. Screw the fixing in position with the two nuts.

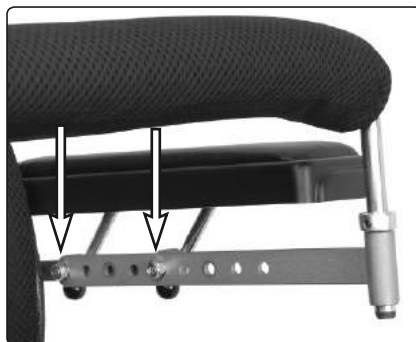

Arm and chest support.

Chest support - Height adjustment

1. Release the Allen screws (1) on the locking ring on either side of the chest support, see photo.
2. Adjust the chest support to a suitable height, but never so high that the fixing is not visible at the lower edge of the sleeve (2), see photo.
3. Tighten the Allen screws on the locking ring.

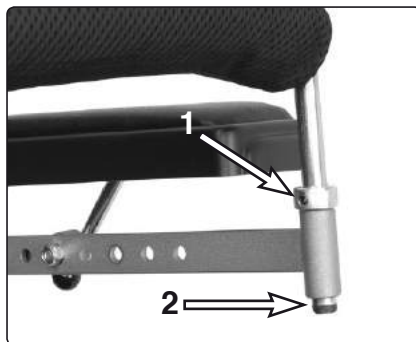

Chest support.



WARNING

Never adjust the height so far that the fixing is not visible at the lower edge of the sleeve.

Settings and adjustment

Head Rest (accessory)

Adjustment of height

1. Release the knob (1) on the rear of the back rest, see photo.
2. Adjust head rest height as required.
3. Tighten the knob (1).

Adjustment forwards/backwards

1. Release the knob (2) on the rear of the back rest, see photo.
2. Adjust the head rest forward/backwards as required.
3. Tighten the knob (2).

Head rest (accessory)

This head rest has extended adjustment capability to give the user the best comfort. The head rest is easy to remove/remount while preserving the same settings.

Removal

1. Release the knob (3) on the rear of the back rest, see photo.
2. Detach the head rest by lifting it straight up.

Mounting

Mount in reverse order.

Adjustment of height/depth

1. Release the knob (1) on the rear of the back rest, see photo.
2. Adjust head rest height/depth as required.
3. Tighten the knob (1).

Adjustment of angle

1. Release the knob (2) on the rear of the head rest, see photo.
2. Adjust head rest angle as required.
3. Tighten the knob (2).

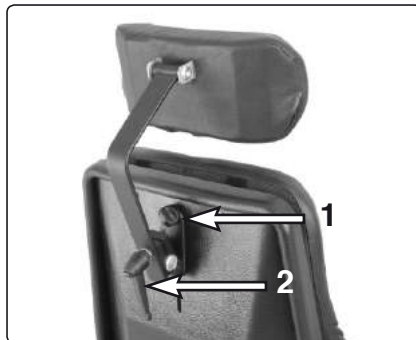

Head rest adjustment.

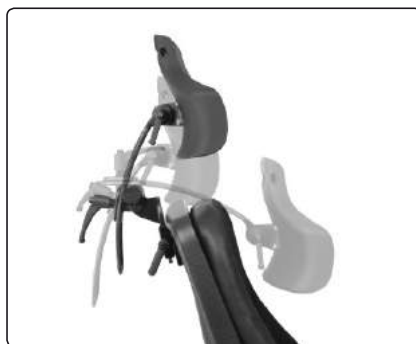

Head rest with wide adjustment capability.

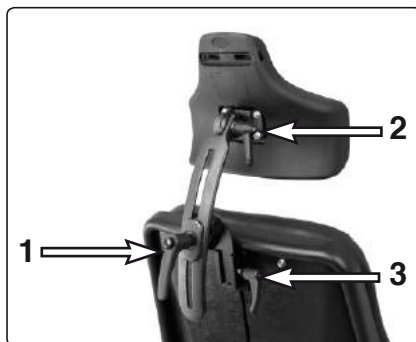

Head rest adjustment.

Settings and adjustment

Trunk support (accessory)

Height adjustment

1. Release the knob on the rear of the back rest, see photo.
2. Adjust the trunk support to the desired height.
3. Retighten the knob.



Adjusting the trunk support.

Lumbar support

Height/depth adjustment

1. Remove the back:
2. Adjust the lumbar support as required.
3. Replace the back cushion.



Adjusting the trunk support.

Settings and adjustment

Foot plate - Angle adjustment

The foot plate angle can be adjusted by screwing the nuts (2) on the foot plate adjustment screws in or out, see photo on right.

Foot plate - Height adjustment.

1. Release the two locking screws (1) on the foot plate, see photo.
2. Adjust the foot plate to the desired height.
3. Retighten the screws.
4. Where necessary, on seats without standing operation function, adjust the height of support wheels so the leg rest does not hit the ground during elevation.

Reversing the foot plate fixing.

If further adjustment of foot plate height is necessary, it is possible to reverse the fixing, which will enable the foot plate to be set higher up.

1. Unscrew the support wheels; on seats with standing operation they are mounted with two screws on either side of the leg rest, while on seats without standing operation they are mounted on the rear edge of the foot plate, see photo.

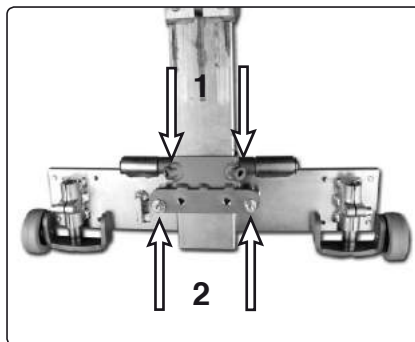

Leg rest seen from behind.

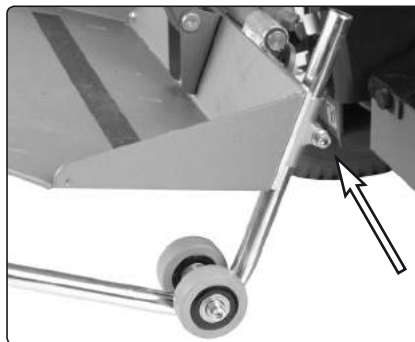

Support wheel fixing on seat without standing operation function.

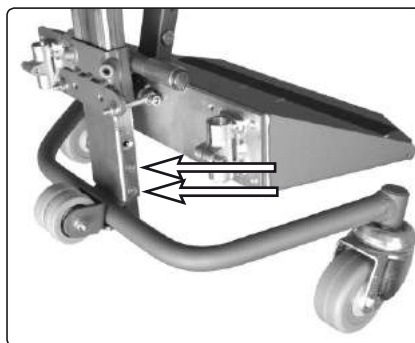

Support wheel fixing on seat with standing operation function.

Settings and adjustment

2. Remove the knee support, mounted with one screw, see Fig. 11.

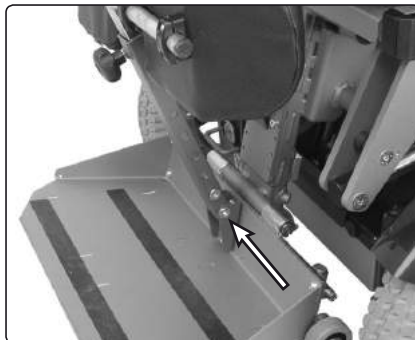

The knee support is mounted with one screw.

3. Unscrew the six screws that hold the foot plate in place, see photo.

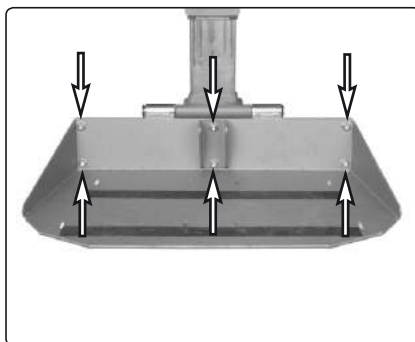

The foot plate is mounted with six screws.

4. Release the two locking screws on the footplate, see photo at the top of the previous page.
5. Turn the fixing over and remount in reverse order.

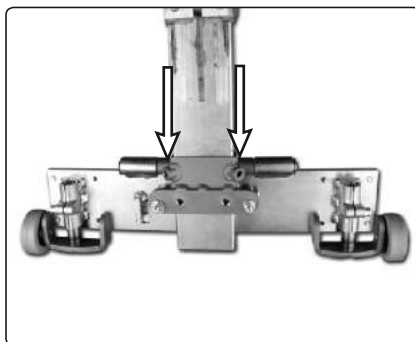

Leg rest seen from behind.

Knee support - Adjustment of position

1. Adjust the knee support in sitting position to a location approx. 3-4 cm in front of the legs. Carry out adjustment with the knob on the rear edge of the seat frame, see photo. Rotate the knob clockwise to reduce the distance between the leg and the knee support and anticlockwise to increase the distance.



Adjusting the position of the knee support.

Knee support - Adjustment of height

1. Release the knee support's locking knob (1), see photo.
2. Move the continuous position screw (2) on the leg rest to a suitable position, see photo.
3. Ensure that the knee support is fully pushed in against the position screw, then tighten the knee support locking knob (1).

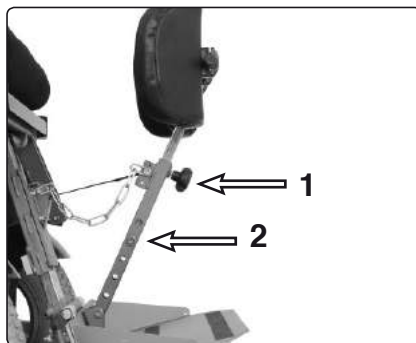

Knee support.

Angle gauge

When starting to use the VS seat, it may be difficult to rise up completely and require a deal of training to rise up to full height in the seat. The supplied angle gauge can be mounted on the seat frame to give an indication of the user's progress.

The angle gauge is self-adhesive on the rear and is mounted on the side of the seat frame, see photo. Its position can be varied depending on what accessories are mounted on the seat - fit it wherever there is space. Fit the angle gauge to show 0° in sitting position.



Mounting the angle gauge.

Positioning Belt (Option)

Fitting the Positioning Belt

There is an accessory rail on both sides of the seat frame for mounting such items as the positioning belt. Mount the positioning belt in the upper track of the rail.

1. Screw the belt in place, with the snap lock on the side which best suits the user and the other part with the buckle on the opposite side.
2. After mounting, check that the belt buckle locks properly in the snap lock.



Fitted Belt.



Fitted Belt.



Snap Lock for the Belt.



WARNING

Permobil positioning belts are designed to position the user only and not to protect you in the event of a motor vehicle accident. The positioning belts do not replace use of a vehicle mounted restraint.

Control panel *(rotating panel holder)*

The location of the control panel can be adjusted lengthwise to find the optimum driving position. It is also possible to adjust the angle of the panel sideways, which facilitates getting in and out.

Length adjustment

1. Undo the screw on the underside of the armrest and adjust the panel to the required position.
2. Tighten the screw.

Adjustment of friction joint

Using the knob on the friction joint, it is possible to adjust how easily or stiffly the panel can be angled laterally.

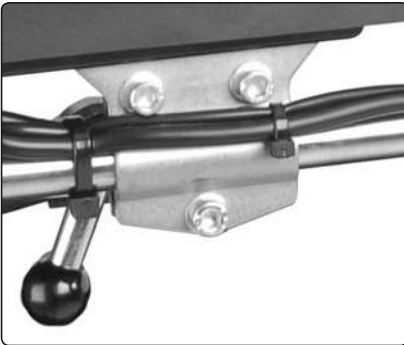

Length adjustment screw



Friction joint knob

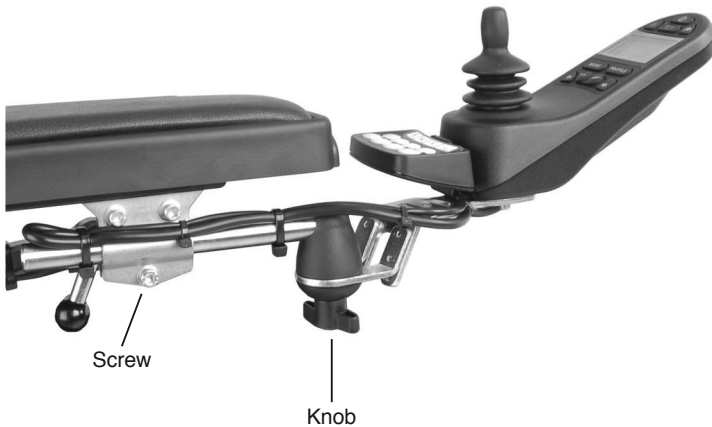

Control panel with rotating panel holder

Control panel *(parallel panel holder)*

The location of the control panel can be adjusted lengthwise to find the optimum driving position. The panel can also be pushed out to the side, diagonally back, to facilitate getting in and out.

Length adjustment

1. Undo the screw on the underside of the armrest and adjust the panel to the required position.
2. Tighten the screw.

Adjustment of friction joint

Using the knob on the friction joint, it is possible to adjust how easily or stiffly the panel can be pushed out to the side.



The panel can be pushed out to the side, diagonally back, to facilitate getting in and out.

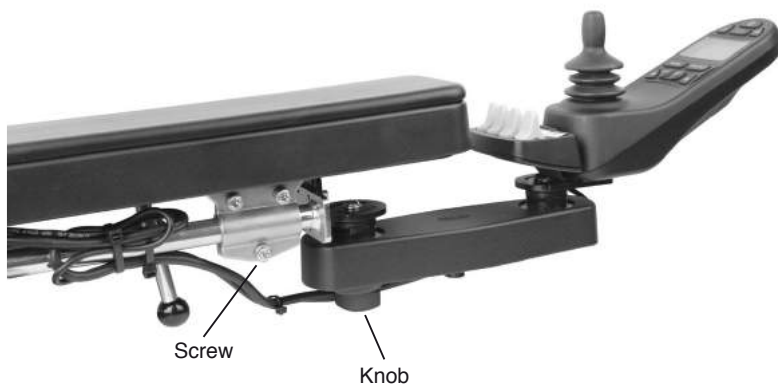

Control panel with parallel panel holder

Care and maintenance

Regular care and maintenance will prevent unnecessary wear and damage to your seat. The following is general advice recommended by Permobil. For severe soiling of the upholstery or damage to surface finish, contact Permobil for information.

Upholstery, cloth/vinyl

For normal cleaning, wash the upholstery with lukewarm water and a mild non-abrasive soap. Use a soft cloth or brush. Before the surface dries, wipe off any water/soap residues with a clean, dry cloth. This procedure may be repeated to remove stubborn dirt or stains.

If necessary, the cover may be removed before cleaning. See also the washing instructions on the upholstery materials.

Metal surfaces

For normal cleaning proceed carefully with a soft cloth/sponge, hot water and a mild detergent. Wipe down carefully with a cloth and water, and dry off.

Remove skuff marks from semi-matte surfaces with soft wax (follow manufacturer's instructions).

Remove skuff marks and scratches from shiny surfaces using car polish, either liquid or in paste form. After polishing, apply soft car wax to restore the original surface gloss.

Plastics

For normal cleaning, wash plastic surfaces with a soft cloth, mild detergent and hot water. Rinse thoroughly and dry with a soft cloth. Do not use solvents or abrasive kitchen cleaners.



WARNING

Never hose the wheelchair down as the electronics may be damaged. The wheelchair must always be turned off when being cleaned.

Care and maintenance

Checks

At regular intervals check the following:

- that the locking nuts on the swivel heads are tight.
- that the actuators are in place in the actuator fixings.
- that the knee stop tape and the tape to the leg rest/foot plate are not worn and that the seams are intact.
- Check the condition of the belts regularly in case any damage or worn places have developed.
- that moving parts such as arm rest or parallel stay are in place and that all knobs are tightened, see safety rules, pages 10-11.
- that the green indicator lamp on the button box goes out when the seat is raised above or lowered below the correct height for elevation.



NOTE

Always contact Service if defects are discovered on the seat, as the use of a defective seat could both injure the user and damage the seat.

Transport

To take up less space when transporting the seat, the back rest can be detached and laid on the seat.

1. Release the two knobs (1) on the rear of the back rest, see photo.
2. Open the two quick-acting locks (2)
3. Lay the back rest on the seat cushion.

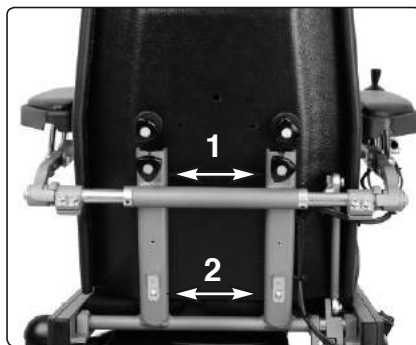

Detaching the back rest.

Technical specifications

Dimensions & weight information	Junior	Adult
Seat height with electric seat lift	21"-31"	21"-31"
Seat width	17"/19"	17"/19"
Seat depth	16"-20"	18"-24" *
Back rest height	22"/24"	22"/24"
Arm rest height	6"-11"	6"-11"
Distance between arm rests	14"/16"/18"	14"/16"/18"
Distance between seat cushion and foot plate	11"-13"	19"-22"
Back rest angle	90°-180°	90°-180°
Leg rest angle	90°-180°	90°-180°
Max. user weight	170 lbs	220/265** lbs

*18"-20" without seat extension

** With seating limitations

US



VS



Order no.: 205216-US-0