

Hardware User's Manual

Tail-flick meter

Tail-flick test



References:

LE7106 (76-0293)

Version:

V29/10/2014x

Limitation of Liability







PANLAB does not accept responsibility, under any circumstances, for any harm or damage caused directly or indirectly by the incorrect interpretation of what is expressed in the pages of this manual.

Some symbols may have more than one interpretation by professionals unaccustomed to their usage.

PANLAB reserves the right to modify, in part or in total, the contents of this document without notice.

1. SYMBOLS TABLE

Recognising the symbols used in the manual will help to understand their meaning:

DESCRIPTION	SYMBOL
Warning about operations that must not be done because they can damage the equipment	
Warning about operations that must be done, otherwise the user can be exposed to a hazard.	
Protection terminal ground connection.	
Warning about a hot surface which temperature may exceed 65°C	
Warning about a metal surface that can supply electrical shock when it's touched.	
Decontamination of equipments prior to disposal at the end of their operative life	
Waste Electrical and Electronic Equipment Directive (WEEE)	

2. GOOD LABORATORY PRACTICE

Check all units periodically and after periods of storage to ensure they are still fit for purpose. Investigate all failures which may indicate a need for service or repair.

Good laboratory practice recommends that the unit be periodically serviced to ensure the unit is suitable for purpose. You must follow preventive maintenance instructions. In case equipment has to be serviced you can arrange this through your distributor. Prior to Inspection, Servicing, Repair or Return of Laboratory Equipment the unit must be cleaned and decontaminated.



Decontamination prior to equipment disposal

In use this product may have been in contact with bio hazardous materials and might therefore carry infectious material. Before disposal the unit and accessories should all be thoroughly decontaminated according to your local environmental safety laws.

3. UNPACKING AND EQUIPMENT INSTALATION



WARNING: Failure to follow the instructions in this section may cause equipment faults or injury to the user.

- A. No special equipment is required for lifting but you should consult your local regulations for safe handling and lifting of the equipment.
- B. Inspect the instrument for any signs of damage caused during transit. If any damage is discovered, do not use the instrument and report the problem to your supplier.
- C. Ensure all transport locks are removed before use. The original packing has been especially designed to protect the instrument during transportation. It is therefore recommended to keep the original carton with its foam parts and accessories box for re-use in case of future shipments. Warranty claims are void if improper packing results in damage during transport.
- D. Place the equipment on a flat surface and leave at least 10 cm of free space between the rear panel of the device and the wall. Never place the equipment in zones with vibration or direct sunlight.
- E. Once the equipment is installed in the final place, the main power switch must be easily accessible.
- F. Only use power cords that have been supplied with the equipment. In case that you have to replace them, the spare ones must have the same specs that the original ones.



- G. Make sure that the AC voltage in the electrical network is the same as the voltage selected in the equipment. **Never connect the equipment to a power outlet with voltage outside these limits.**



WARNING

For electrical safety reasons you only can connect equipment to power outlets provided with earth connections .

This equipment can be used in installations with category II over-voltage according to the General Safety Rules.

The manufacturer accepts no responsibility for improper use of the equipment or the consequences of use other than that for which it has been designed.

PC Control

Some of these instruments are designed to be controlled from a PC. To preserve the integrity of the equipment it is essential that the attached PC itself conforms to basic safety and EMC standards and is set up in accordance with the manufacturers' instructions. If in doubt consult the information that came with your PC. In common with all computer operation the following safety precautions are advised.



- WARNING**
- To reduce the chance of eye strain, set up the PC display with the correct viewing position, free from glare and with appropriate brightness and contrast settings
 - To reduce the chance of physical strain, set up the PC display, keyboard and mouse with correct ergonomic positioning, according to your local safety guidelines.

4. MAINTENANCE



WARNING: Failure to follow the instructions in this section may cause equipment fault.

- PRESS KEYS SOFTLY – Lightly pressing the keys is sufficient to activate them.
- Equipments do not require being disinfected, but cleaned for removing urine, faeces and odour. To do so, we recommend using a wet cloth or paper with soap (which has no strong odour). NEVER USE ABRASIVE PRODUCTS OR DISSOLVENTS.
- NEVER pour water or liquids on the equipment.
- Once you have finished using the equipment turn it off with the main switch. Clean and check the equipment so that it is in optimal condition for its next use.
- The user is only authorised to replace fuses with the specified type when necessary.

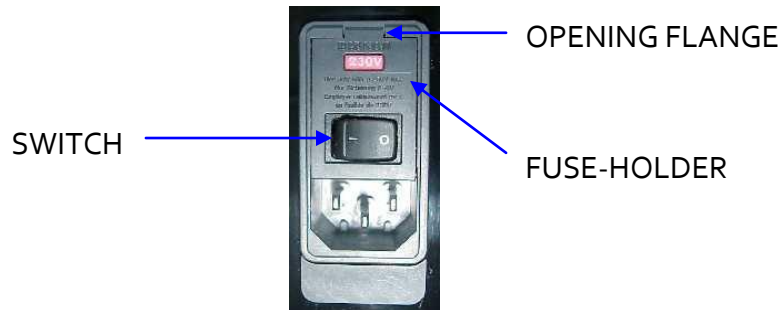

Figure 1. Power inlet, main switch and fuse holder.

FUSE REPLACEMENT

In case of an over-voltage or other incident in the AC net making it impossible to turn on the equipment, check fuses according to the following procedure.

- 1 Remove power cord from the power inlet

- 2 Open fuse-holder by pulling the flange with a regular screwdriver



Figure 2. Open fuse-holder door.

- 3 Extract fuse holder using the screwdriver.



Figure 3. Extract fuse-holder.

- 4 Replace fuses if necessary. Insert fuses in the fuse-holder in the correct position.



CORRECT



INCORRECT

Figure 4. Fuses position.

- 5 Insert again fuse-holder, both possible positions are correct because power supply is universal.
- 6 If the fuses blow again unplug the equipment and contact technical service.



For electrical safety, never open the equipment. The power supply has dangerous voltages.

5. TABLE OF CONTENTS

1.	SYMBOLS TABLE	2
2.	GOOD LABORATORY PRACTICE	2
3.	UNPACKING AND EQUIPMENT INSTALATION	3
4.	MAINTENANCE	5
5.	TABLE OF CONTENTS	7
6.	INTRODUCTION	8
6.1.	SUPPLIED ACCESSORIES	8
7.	EQUIPMENT DESCRIPTION	9
7.1.	CONTROL UNIT FRONT PANEL	9
7.2.	CONTROL UNIT REAR PANEL	10
7.3.	EXPERIMENTATION UNIT	11
8.	EQUIPMENT CONNECTION	12
9.	CHANGING THE LAMP	13
10.	WORKING WITH THE EQUIPMENT	14
11.	RECOMMENDATIONS	16
11.1.	CLEANING THE RESTRAINER	16
11.2.	CLEANING THE EXPERIMENTATION UNIT AND V-HAPPED ACCESORY	16
12.	SING THE COMMUNICATIONS PROGRAM	17
13.	CHANGING SAFETY TIME	18
14.	TROUBLESHOOTING	19
15.	PREVENTIVE MAINTENANCE	20
16.	TECHNICAL SPECIFICATIONS	21

6. INTRODUCTION

The LE 7106 Light Beam Analgesy meter is designed to provide all the necessary technical elements to measure the response of rats and mice to pain stimulation by means of a radiant heat applied to their tails.



Figure 5. LE 7106 Light Beam Analgesy Meter.

The analgesy meter has an adjustable intensity heat source, a photoelectric-based animal response detector and a response latency chronometer with 0.01 second resolution.

The analgesy meter is standard-equipped with a maximum stimulus duration of 20 seconds. This prevents tissue damage due to excessively prolonged stimulation. This time setting can be modified (see chapter 13).

6.1. SUPPLIED ACCESSORIES

- LE 7106 Control Unit (1).
- Experimenting Unit (1).
- Interconnection cable between Units (1).
- Power cord (1).
- RS-232 wire (1).
- V shaped accessory(1).
- Foot switch (1).
- Restrainer (1).
- As option customer is able to order a calibration certificate.¹

¹ This certificate is not supplied by default with the instrument. This certificate is not free of cost and must be done in factory.

7. EQUIPMENT DESCRIPTION

7.1. CONTROL UNIT FRONT PANEL

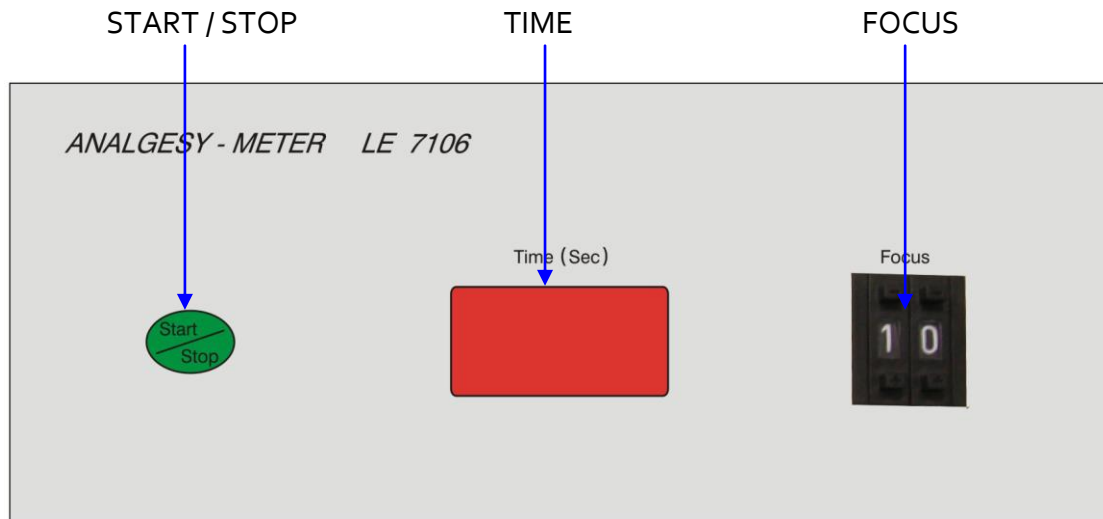

Figure 6. Control Unit Front Panel.

- **START/STOP:** The lamp is turned on by pressing this button. If it were necessary to turn off the lamp before the animal had moved its tail this button can be pressed again. When the START button is pressed, time will increase until the animal moves its tail. At that time the lamp is cut off and time stops.
- **TIME:** A 4-digit display that counts time while the lamp is on. If time reaches 20.00 the system will automatically turn off the lamp and the error message **Cut** (Cut off) will be shown on the display (this is a safety measure to prevent harm to the animal).
- **FOCUS:** Decimal selector of heat intensity. It can be set from 10 to 99.

7.2. CONTROL UNIT REAR PANEL

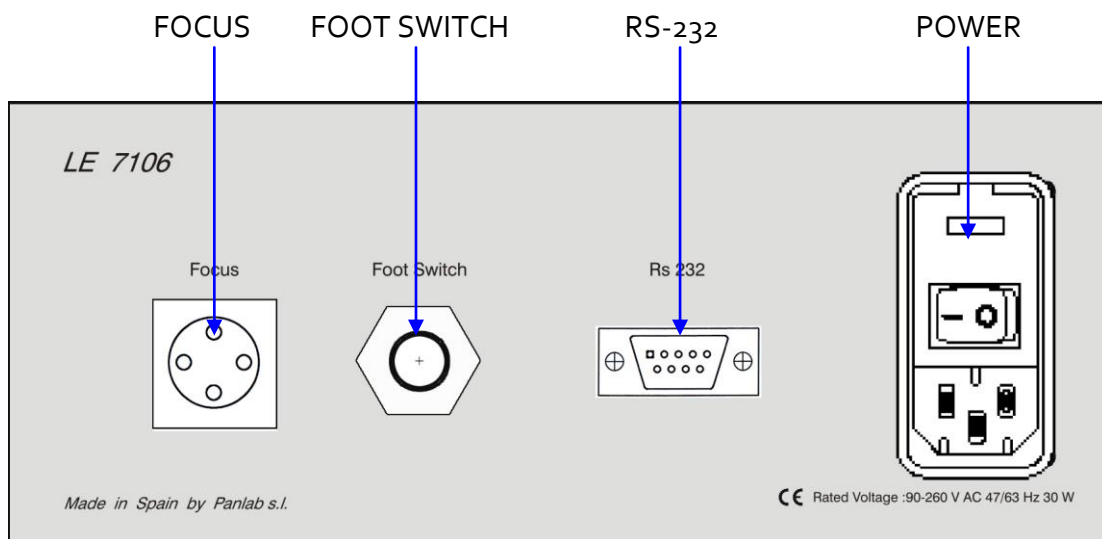

Figure 7. Control Unit Rear Panel.

- **FOCUS:** 4 pin connector that sends power to the lamp and sends light detection information from the phototransistor to the control unit.
- **FOOT SWITCH:** System can be activated remotely using a foot switch. It has the same function as the START/STOP button on the front panel.
- **RS-232:** Data are transmitted through this DB9 connector to the computer by the serial port using the Sedacom software (not included, should be purchased separately). Data are sent to the computer each time a correct test is completed (lamp is turned off because the animal moves its tail). If a test is finished by pressing STOP or time reaches 20.00 then data will not be sent to the computer.
- **POWER:** Power inlet, main switch and fuse holder.

7.3. EXPERIMENTATION UNIT

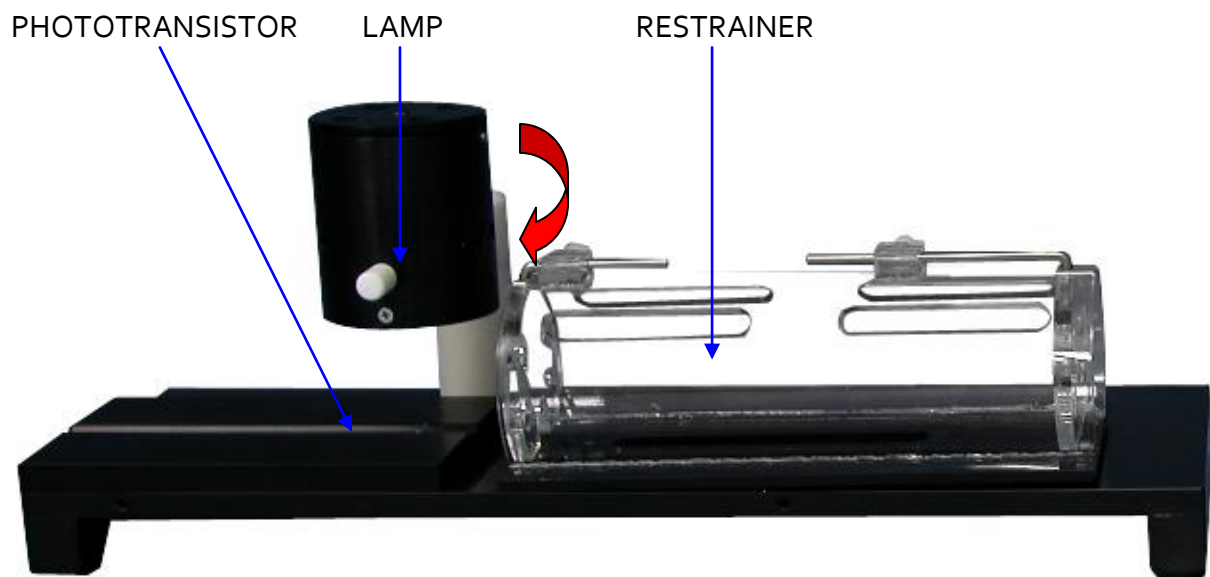

Figure 8. Experimentation Unit.

- **PHOTOTRANSISTOR:** A phototransistor detects light when the animal moves its tail.
- **LAMP:** Heat is produced by a halogen lamp (see technical specifications for further details). The lamp holder turns around its vertical axis to withdraw the lamp and facilitate placement of the animal. Never turn the lamp on if it is not positioned over the phototransistor as it can produce high temperatures.
- **RESTRAINER:** Animal is kept in a restrainer. There are 2 metal cylinders in which to correctly position the restrainer on the platform.
- **ACCESSORY:** It is strongly advised to work with the accessory at all times. It is a V- shaped metal unit that must be placed over the phototransistor. It protects the phototransistor from ambient light and lamp light. It is very important to place the orifice of this piece over the phototransistor (see marks on the unit). If it is placed in an incorrect position the light will never be detected and time will reach 20.00. The small orifice reduces the amount of light that reaches the phototransistor and makes the system less sensitive to light.

8. EQUIPMENT CONNECTION

The following figure shows the equipment connection:

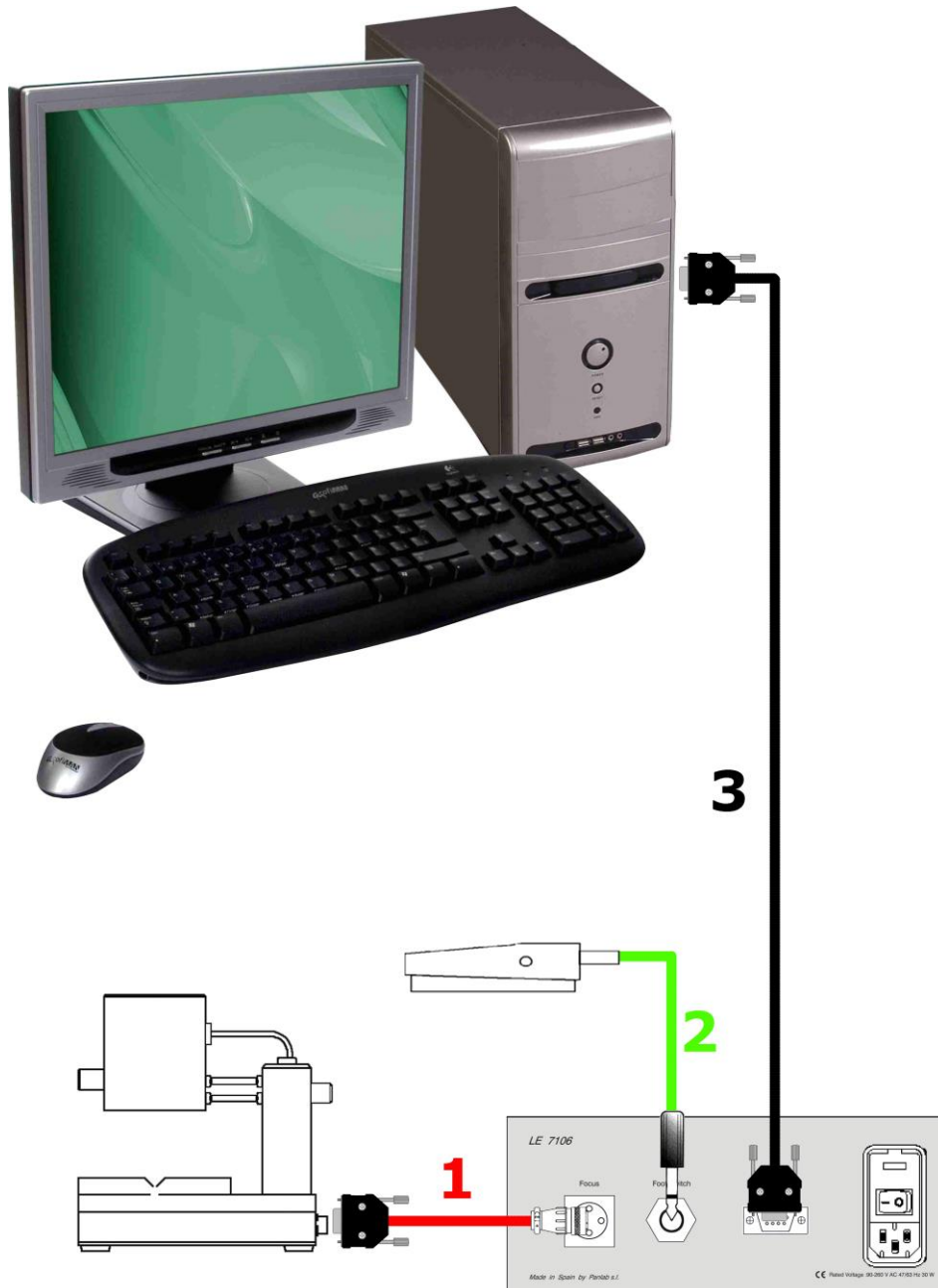

Figure 9. Equipment connection.

The cables and connections are listed below:

	FROM	TO	CABLE
1	Lamp unit	LE7106 FOCUS	DB9 to 4 pins cable
2	LE7106 FOOT SWITCH	FOOT SWITCH	6,35mm Jack mono cable
3	LE7106 RS-232	Computer Com Port	RS-232 cable

9. CHANGING THE LAMP

This type of halogen lamp has a very long service life. Nonetheless, if you have to change one please follow these instructions.

1. To remove the cover, press down and turn it clockwise.

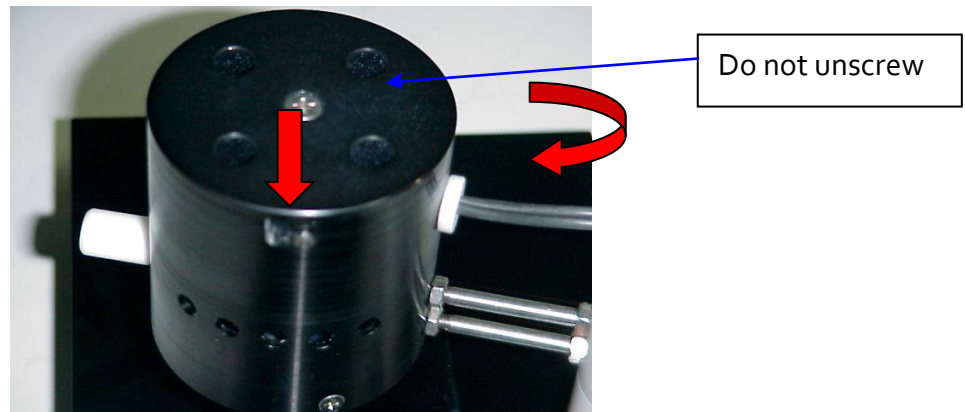

Figure 10. Remove the top cover.

2. Then proceed to extract the bulb and unscrew the electrical contacts.
3. Change the light bulb, screw again the contacts and place it in its correct position inside the lamp.



Figure 11. Unscrew the wires and change the lamp.

4. Lastly place the cover in its correct position

WARNING: Never touch the lamp directly with your fingers. If you have touched the lamp, clean it carefully with an alcohol-based cleaner and a dry cloth.

10. WORKING WITH THE EQUIPMENT

1. Turn the control unit ON, ensuring correct connection between it and the experimentation unit.

2. Adjust the INTENSITY to the desired heat, using the  selector.

3. Move the lamp to its back position.

4. Prepare the animal, placing it in the restrainer. Then place the restrainer on the platform with the help of the 2 small metal cylinders, and leave the animal's tail over the phototransistor.

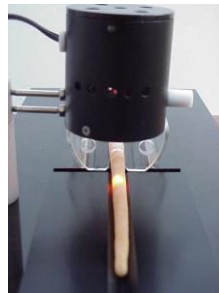



Figure 12. Preparation of the animal.

5. Move the lamp to its most frontal position.

6. Press . The lamp and the chronometer will run until a tail flick is detected.

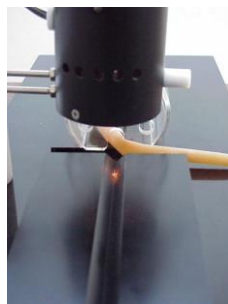

Figure 13. The animal moves its tail.

7. Return the lamp to its BACK POSITION.

8. Take note of the response time (if you are not using SEDACOM to record the experimental data, otherwise data are automatically sent to the computer), and prepare a new animal, repeating the process as many times as necessary.

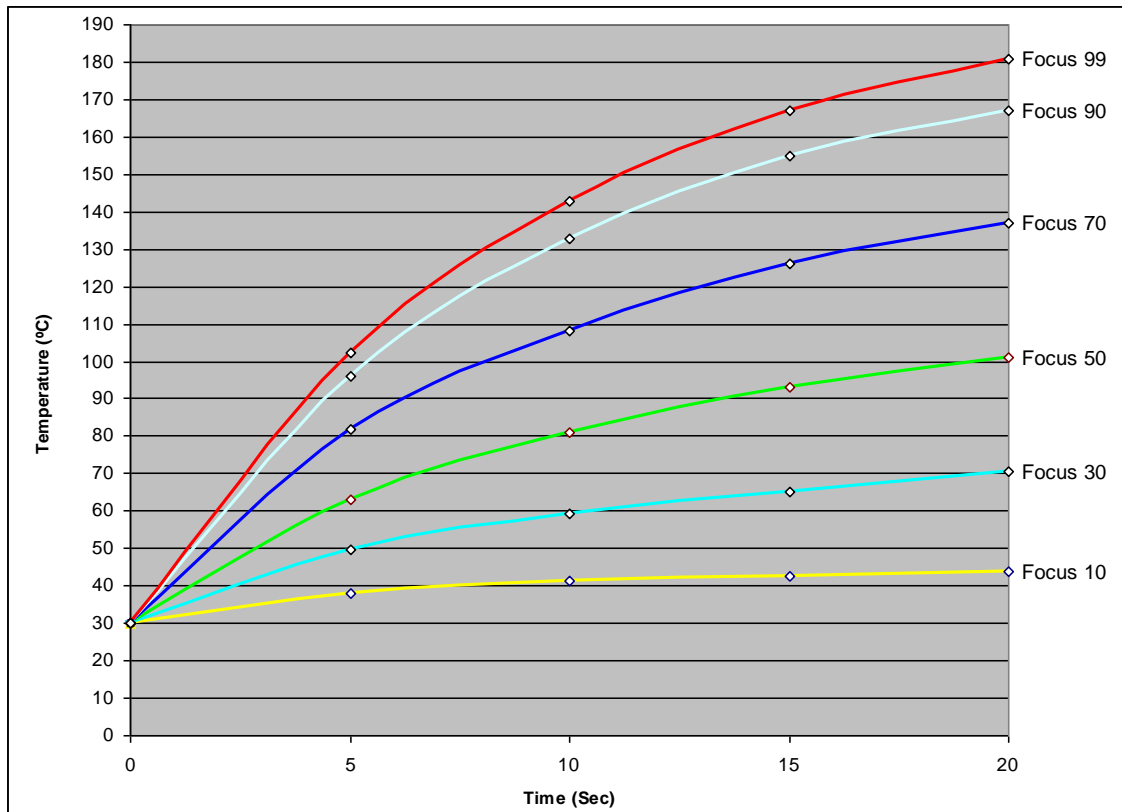

Figure 14. Temperature versus time at different focus intensity.

The above graph displays the evolution of temperature versus time with different focus intensities.



WARNING: The temperature of the lamp can be up to 200°C

11. RECOMMENDATIONS

1. When working with mice, as they have very thin tails, it is advisable to use low focus values as to prevent harm to their tails.
2. When working with rats, as they have thick tails, it is possible that low focus values will not be able to stimulate the animal. In that case it will be necessary to increase the focus value.
3. Periodically, it will be necessary to clean the experimentation unit and ensure that the accessory (V-shaped metal unit) is correctly positioned.
4. Once the animal is placed in the restrainer, it will be necessary to wait for 2 minutes for it to calm down. This way, false measurements of movements caused by animal stress will be avoided.

11.1. CLEANING THE RESTRAINER



WARNING: In order to clean the restrainer never use neither alcohol nor alcoholic derived products, otherwise stripes will appear in the transparent plastic.

To clean the restrainer you can use a slightly wet cloth and then dry it with a dry cloth. If it's too dirty you can wet the cloth with a soapy solution, then remove foam with a wet cloth and finally dry it with a dry cloth.

11.2. CLEANING THE EXPERIMENTATION UNIT AND V-HAPPED ACCESSORY

To clean the surface of experimentation unit and the V-shaped accessory you can use a slightly wet cloth and then dry it with a dry cloth. If they're too dirty you can wet the cloth with a soapy solution, then remove foam with a wet cloth and finally dry it with a dry cloth.

12. SING THE COMMUNICATIONS PROGRAM

The purchase of the **Sedacom** software is needed for transferring the data to a computer (please contact your local sales delegate for more information). The **Sedacom** software reference is composed by a USB Flash key containing the software Installer, a License for use and the **Sedacom** User's Manual). Follow next instructions:

- Please refer to the **Sedacom** User's Manual for the instructions about how to install and use the software with the present device.
- A serial port (RS232) communication cable (provided with the present device) is needed for the connection of the present devices to the computer in which the **Sedacom** software is installed. Please refer to the present User's Manual for the instruction about how to connect this cable to the device.
- If the computer doesn't have any serial port, the RS232/USB adapter is needed (ref. CONRS232USB, contact your local sales delegate for more information)

WARNING: the RS232 communication cable provided with the device is used for any connection of the device with associated software (**Sedacom**, etc.). When the device is used without software in first instance, this cable need to be preserved and kept in secure place in case the need of using the system with a software is required in the future. In this last case, if the user lost the cable, a new one should be purchased to his local sales delegate (ref. CONRS232). The warranty time of this cable is the same than the warranty time of the device.

13. CHANGING SAFETY TIME

If there is no animal response, the light automatically cuts off after 20 seconds to prevent harm to the animal's tail. This safety time can be modified with internal micro-switches as follows.

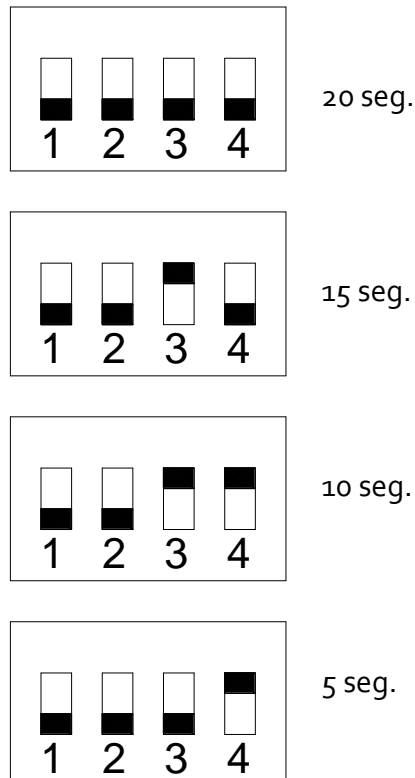
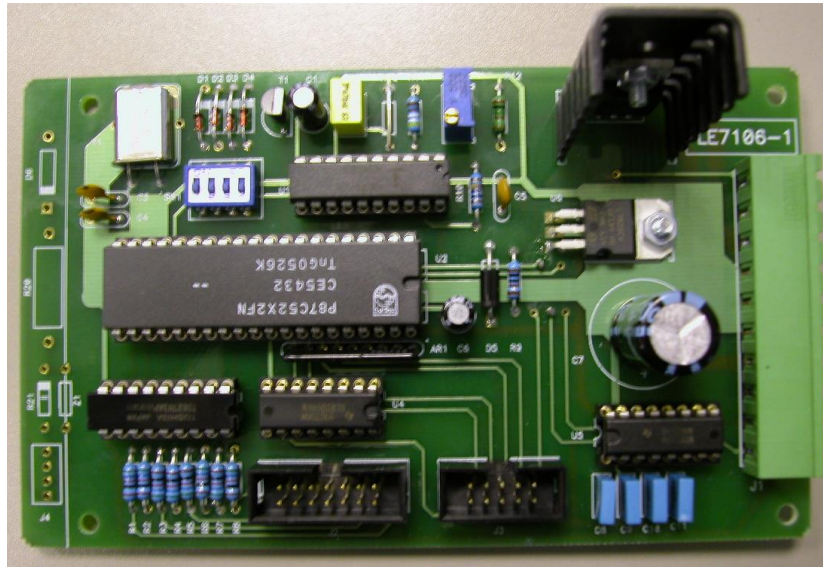

Figure 15. Changing safety time.

14. TROUBLESHOOTING

This table features instructions to solve the most frequent problems.

PROBLEM	SOLUTION
The equipment does not start up.	<ul style="list-style-type: none"> • Check the condition of the fuses.
The equipment does not send data to the program Sedacom .	<ul style="list-style-type: none"> • Check that the cable is connected between the RS-232 device and the PC serial port (see Figure 9). • Make sure that both the serial port as the device selected in the Sedacom program are correct. • The equipment will only send data when after the experiment starts, the lamp turns off because the animal has removed the tail. If the lamp turns off because has reached the safety time (see Chapter 13) will not send data.
By pressing START/STOP button or pedal lamp is not lit.	<ul style="list-style-type: none"> • Check that the cable is connected to the lamp (see Figure 9). • If it starts counting the time, but the lamp does not light, check the condition of the lamp. • If the two items are correct, it could be a fault in the membrane button.
When the animal removes the tail the lamp does not turn off.	<ul style="list-style-type: none"> • Verify that the V shaped accessory is properly seated in. • Make sure the hole is clean in the V shaped accessory; if it is clogged with dirt will not allow the passage of light. • Clean the phototransistor located in the lamp, if it is dirt can prevent light to be detected
FOCUS selector cannot select values below 10.	<ul style="list-style-type: none"> • There is not an error, the dial has a brake that prevents selecting values below 10.
Can I calibrate the lamp?	<ul style="list-style-type: none"> • Lamp cannot be calibrated by the user. As option there is a calibration certificate that must be done in factory and it's not cost free.

15. PREVENTIVE MAINTENANCE

	EXPERIMENT	WHEN NECESSARY
CLEAN V-SHAPED ACCESSORY	<input checked="" type="checkbox"/>	
CLEAN EXPERIMENTATION UNIT SURFACE	<input checked="" type="checkbox"/>	
RESTRAINER CLEANING	<input checked="" type="checkbox"/>	
CHANGE THE LAMP ²		<input checked="" type="checkbox"/>
CHANGE SAFETY TIME ³		<input checked="" type="checkbox"/>
CHECK CABLES CONNECTION	<input checked="" type="checkbox"/>	

² See chapter 9.

³ See chapter 13.

16. TECHNICAL SPECIFICATIONS

<p>POWER SUPPLY Input voltage: Frequency: Fuse: Maximum Power: Conducted Noise:</p>	<p>Universal input 100-240V AC 50/60 Hz 2 fuses 5mm*20mm 2A 250V Fast 36W EN55022 /CISPR22/CISPR16 class B</p>										
<p>ENVIRONMENTAL CONDITIONS Operating temperature: Operating Relative Humidity: Storage temperature:</p>	<p>10°C to +40°C 0% to 85% RH, non-condensing 0°C to +50°C, non-condensing</p>										
<p>COMUNICATIONS OUTPUT Standard Interface: Connector:</p>	<p>RS232C Delta 9 contacts female connector</p>										
<p>FRONT PANEL Beam Intensity: Display: Max. Time: Precision:</p>	<p>Adjustable in the interval 10-99 4 Digits 99.99 s limited to 20 seconds 0.01 s</p>										
<p>CONNECTOR FOCUS</p> <table border="0"> <tr> <td><u>Pin</u></td> <td><u>Function</u></td> </tr> <tr> <td>A</td> <td>+5V</td> </tr> <tr> <td>B</td> <td>Lamp</td> </tr> <tr> <td>C</td> <td>Input</td> </tr> <tr> <td>D</td> <td>Lamp</td> </tr> </table>	<u>Pin</u>	<u>Function</u>	A	+5V	B	Lamp	C	Input	D	Lamp	
<u>Pin</u>	<u>Function</u>										
A	+5V										
B	Lamp										
C	Input										
D	Lamp										
<p>CONNECTOR RS232</p> <table border="0"> <tr> <td><u>Pin</u></td> <td><u>Function</u></td> </tr> <tr> <td>3</td> <td>Txd</td> </tr> <tr> <td>5</td> <td>Gnd</td> </tr> </table>	<u>Pin</u>	<u>Function</u>	3	Txd	5	Gnd					
<u>Pin</u>	<u>Function</u>										
3	Txd										
5	Gnd										
<p>LAMP Model: Voltage: Power: Operative life: Number of measurements: Temperature error; (never use other brands or lamps)</p>	<p>Halogen OSRAM 64607 8V 50W 4500 h @ Focus=50 249000 @ Focus =50 1,5% - 2% d depending on the focus and time</p>										
<p>DIMENSIONS Width x Height x Depth: Weight:</p>	<p>232mm*111mm*297mm 3.65kg</p>										

**DECLARACIÓN DE CONFORMIDAD
DECLARATION OF CONFORMITY
DECLARATION DE CONFORMITÉ**

Nombre del fabricante: **Panlab s.l.u.**
 Manufacturer's name: www.panlab.com
 Nom du fabricant: info@panlab.com

Dirección del fabricante: **Energía, 112**
 Manufacturer's address: **08940 Cornellà de Llobregat**
 Adresse du fabricant: **Barcelona SPAIN**

Declara bajo su responsabilidad que el producto: **LIGHT BEAM ANALGESY METER**
 Declares under his responsibility that the product:
 Déclare sous sa responsabilité que le produit:

Marca / Brand / Marque: **PANLAB**

Modelo / Model / Modèle: **LE 7106**

Cumple los requisitos esenciales establecidos por la Unión Europea en las directivas siguientes:
 Fulfills the essential requirements established by The European Union in the following directives:
 Remplit les exigences essentielles établies pour l'Union Européenne selon les directives suivantes:

2006/95/EC	Directiva de baja tensión / Low Voltage / Basse tension
2004/108/EC	Directiva EMC / EMC Directive / Directive CEM
2012/19/EU	La Directiva de Residuos de Aparatos Eléctricos y Electrónicos (WEEE) / The Waste Electrical and Electronic Equipment Directive (WEEE) / Les déchets d'équipements électriques et électroniques (WEEE)
2011/65/EU	Restricción de ciertas Sustancias Peligrosas en aparatos eléctricos y electrónicos (ROHS) / Restriction of the use of certain Hazardous Substances in electrical and electronic equipment (ROHS) / Restriction de l'utilisation de certaines substances dangereuses dans les équipements électriques et électroniques (ROHS)
2006/42/EC	Directiva mecánica / Machinery directive / Directive mécanique

Para su evaluación se han aplicado las normas armonizadas siguientes:
 For its evaluation, the following harmonized standards were applied:
 Pour son évaluation, nous avons appliqué les normes harmonisées suivantes:

Seguridad / Safety / Sécurité:	EN61010-1:2011
EMC:	EN61326-1:2012 Class B
FCC:	FCC47CFR 15B Class B
Safety of machinery:	EN ISO 12100:2010

En consecuencia, este producto puede incorporar el marcado CE y FCC:
 Consequently, this product can incorporate the CE marking and FCC:
 En conséquence, ce produit peut incorporer le marquage CE et FCC:



En representación del fabricante:
 Manufacturer's representative:
 En représentation du fabricant: **Carme Canalís**
General Manager
Panlab s.l.u., a division of Harvard BioScience

Cornellà de Llobregat, Spain
 15/10/2014

(GB) Note on environmental protection:



After the implementation of the European Directive 2002/96/EU in the national legal system, the following applies:

Electrical and electronic devices may not be disposed of with domestic waste. Consumers are obliged by law to return electrical and electronic devices at the end of their service lives to the public collecting points set up for this purpose or point of sale. Details to this are defined by the national law of the respective country. This symbol on the product, the instruction manual or the package indicates that a product is subject to these regulations. By recycling, reusing the materials or other forms of utilising old devices, you are making an important contribution to protecting our environment.

(E) Nota sobre la protección medioambiental:



Después de la puesta en marcha de la directiva Europea 2002/96/EU en el sistema legislativo nacional, Se aplicara lo siguiente:

Los aparatos eléctricos y electrónicos, así como pilas y baterías, no se deben tirar a la basura doméstica. El usuario está legalmente obligado a llevar los aparatos eléctricos y electrónicos, así como pilas y baterías, al final de su vida útil a los puntos de recogida municipales o devolverlos al lugar donde los adquirió. Los detalles quedaran definidos por la ley de cada país. El símbolo en el producto, en las instrucciones de uso o en el embalaje hace referencia a ello. Gracias al reciclaje, a la reutilización de materiales i a otras formas de reciclaje de aparatos usados, usted contribuirá de forma importante a la protección de nuestro medio ambiente.

(F) Remarques concernant la protection de l'environnement :



Conformément à la directive européenne 2002/96/CE, et afin d'atteindre un certain nombre d'objectifs en matière de protection de l'environnement, les règles suivantes doivent être appliquées.

Elles concernent les déchets d'équipement électriques et électroniques. Le pictogramme "picto" présent sur le produit, son manuel d'utilisation ou son emballage indique que le produit est soumis à cette réglementation. Le consommateur doit retourner le produit usager aux points de collecte prévus à cet effet. Il peut aussi le remettre à un revendeur. En permettant enfin le recyclage des produits, le consommateur contribuera à la protection de notre environnement. C'est un acte écologique.

(D) Hinweis zum Umweltschutz:



Ab dem Zeitpunkt der Umsetzung der europäischen Richtlinie 2002/96/EU in nationales Recht gilt folgendes:

Elektrische und elektronische Geräte dürfen nicht mit dem Hausmüll entsorgt werden. Der Verbraucher ist gesetzlich verpflichtet, elektrische und elektronische Geräte am Ende ihrer Lebensdauer an den dafür eingerichteten, öffentlichen Sammelstellen oder an die Verkaufsstelle zurückzugeben. Einzelheiten dazu regelt das jeweilige Landesrecht. Das Symbol auf dem Produkt, der Gebrauchsanleitung oder der Verpackung weist auf diese Bestimmungen hin. Mit der Wiederverwertung, der stofflichen Verwertung oder anderer Formen der Verwertung von Altgeräten leisten Sie einen wichtigen Beitrag zum Schutz unserer Umwelt.

(I) Informazioni per protezione ambientale:



Dopo l'implementazione della Direttiva Europea 2002/96/EU nel sistema legale nazionale, ci sono le seguenti applicazioni:

I dispositivi elettrici ed elettronici non devono essere considerati rifiuti domestici. I consumatori sono obbligati dalla legge a restituire i dispositivi elettrici ed elettronici alla fine della loro vita utile ai punti di raccolta collettivi preposti per questo scopo o nei punti vendita. Dettagli di quanto riportato sono definiti dalle leggi nazionali di ogni stato. Questo simbolo sul prodotto, sul manuale d'istruzioni o sull'imballo indicano che questo prodotto è soggetto a queste regole. Dal riciclo, e re-utilizzo del material o altre forme di utilizzo di dispositivi obsoleti, voi renderete un importante contributo alla protezione dell'ambiente.

(P) Nota em Protecção Ambiental:



Após a implementação da directiva comunitária 2002/96/EU no sistema legal nacional, o seguinte aplica-se:

Todos os aparelhos eléctricos e electrónicos não podem ser despejados juntamente com o lixo doméstico. Consumidores estão obrigados por lei a colocar os aparelhos eléctricos e electrónicos sem uso em locais públicos específicos para este efeito ou no ponto de venda. Os detalhes para este processo são definidos por lei pelos respectivos países. Este símbolo no produto, o manual de instruções ou a embalagem indicam que o produto está sujeito a estes regulamentos. Reciclando, reutilizando os materiais dos seus velhos aparelhos, esta a fazer uma enorme contribuição para a protecção do ambiente.