

# Lincat

## FUME FILTRATION UNIT

L3

L4

## USER AND INSTALLATION INSTRUCTIONS

Dear Customer

Thank you for purchasing this **Lincat** product.

With correct use and careful maintenance as described in these instructions, your **Lincat** product will give years of trouble free use.

We produce over 400 different items of catering equipment and our range is constantly being extended and improved. Find out more about **Lincat** products from your local distributor or direct from us.

## CONTENTS

CONTENTS .....	2
SAFETY INFORMATION .....	2
DELIVERY CHECKLIST .....	3
TECHNICAL SPECIFICATION .....	3
INSTALLATION .....	3
OPERATION.....	5
CLEANING.....	6
MAINTENANCE.....	7
SPARE PARTS.....	7
SERVICE INFORMATION .....	8
GUARANTEE.....	8



## SAFETY INFORMATION

**To prevent injury to yourself or your staff, and to avoid damaging the product, please read and follow the safety precautions below before setting up and using the unit:**

- Remove all plastic coatings and clean the unit before use.
- Ensure that the electrical supply cable is not damaged. If it is, it must be replaced by Lincat Ltd or by qualified personnel.
- Always disconnect the unit from the electricity supply before servicing.
- The unit must be earthed.
- Do not try to modify this unit.
- Keep these instructions in a safe place for future reference.

## DELIVERY CHECKLIST

- Electric fume filtration unit (With electrical supply cable and 10A plug).
- User & installation instructions.
- Guarantee card.
- Aluminium filters (L3 x 2, L4 x 3)
- Carbon filters (L3 x 2, L4 x 3)

If an item is missing please contact your dealer.

## TECHNICAL SPECIFICATION

Model		L3	L4
Width	mm	915	1295
Depth	mm	610	610
Height	mm	545	545
Power Rating	kW	0.35	0.4
Net weight net	kg	30	40

## INSTALLATION

- Remove the protective plastic coating from all metal surfaces.
- Unlatch the front flap and slide out the filters.
- Ensure that the wall on which the filtration unit is to be fitted is suitable for supporting the appliance via the masonry plugs.
- Ensure ample room ventilation with no cross draughts (7 – 10 air changes per hour.)
- Install the filtration unit so that there is an air space above it, with the front lower edge of the canopy about 800mm above the cooking surface. The front edge should overlap the cooking area by approximately 100mm.
- For safety regulations the plug or means of disconnection must always be accessible
- Using a no.4 masonry drill, drill holes in a suitable wall as shown in Fig 1. for the L4 and Fig 2. for the L3. Insert rawl plugs into holes. Hang the unit onto screws in the bottom row of holes and then secure in place by screwing through the fan covers into the top row of holes.

Fig 1.

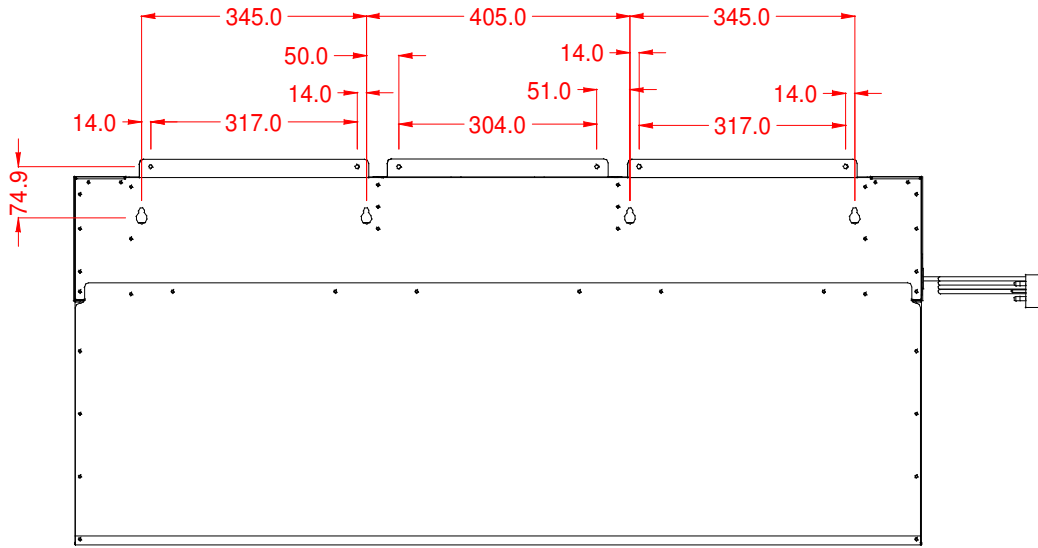
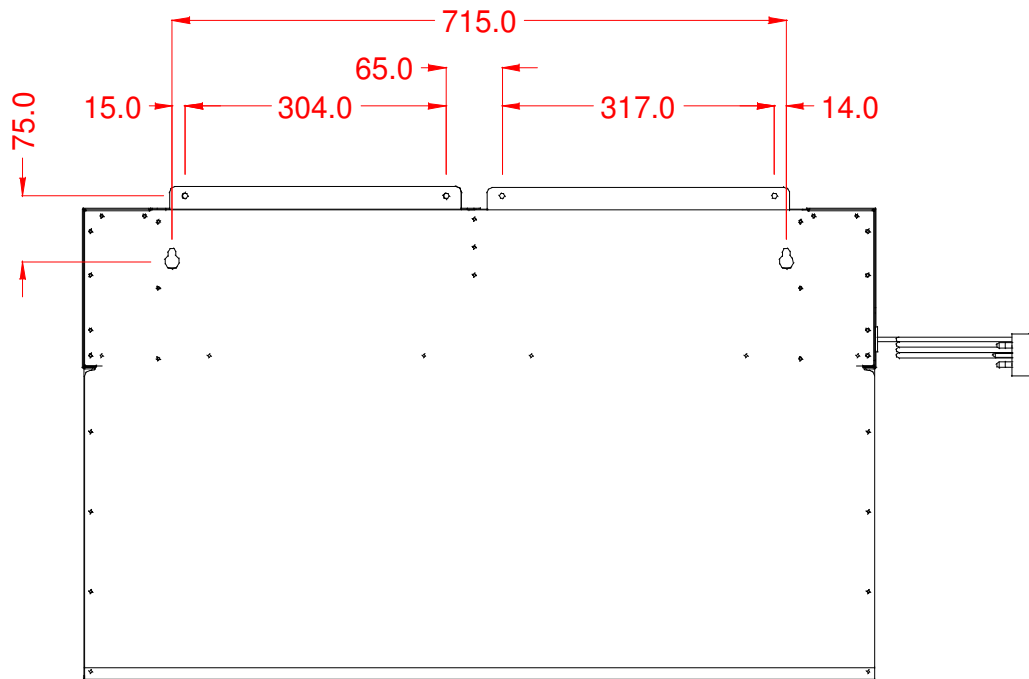

Fig 2.



## CONNECTING TO THE ELECTRICITY SUPPLY

The unit must be earthed

Check that the voltage of your electricity supply corresponds to the voltage shown on the serial plate

The product is supplied with a 10 amp plug. If replacing the plug, connect the terminals as follows:

- Green and yellow wire    Earth    E
- Blue wire                    Neutral    N
- Brown wire                  Live        L

## OPERATION

- Plug the unit into the mains supply.
- Turn the power switch on as indicated in Fig 3, the fans will run until the unit is switched off.
- To use the lights, turn on the light switch as indicated in Fig 3.

Figure 3.

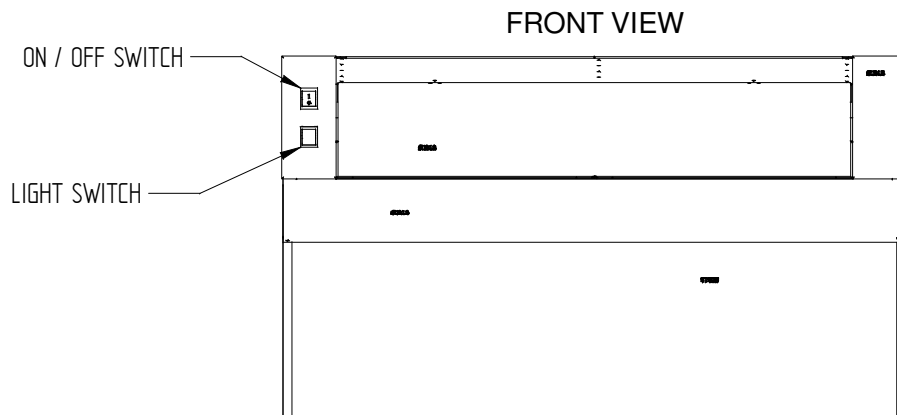

- This unit is fitted with a safety thermostat which will cut power to the fans in the event of a fire. To re-set the safety thermostat, press in the button as indicated in Fig 4.

Figure 4.

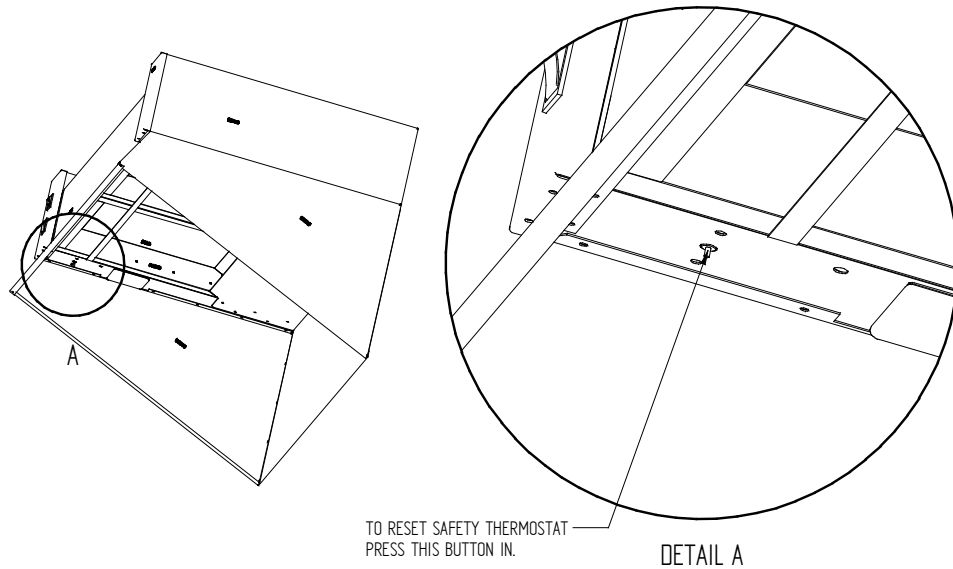

## CLEANING

**Important: Take care not to damage the thermostat capillary when cleaning.**

Clean the unit regularly to maintain efficient performance and hygiene. Disconnect the unit from the electricity supply and allow to cool before starting to clean

Use a mild detergent in hot water and a soft cloth.

Do not allow excess water to run into the unit.

Do not use abrasive creams or scourers.

Burnt-on food may be removed using Carb'n'off or similar cleaner

## MAINTENANCE

The parts listed below can be replaced by the user. No other regular maintenance is required.

### Lamp Bulb

- Ensure that the unit is turned off and unplugged from the mains.
- Carefully prise glass cover off using a small flat bladed screwdriver.
- Replace old bulb.
- Re-fit glass cover.

### Filters

- Ensure that the unit is turned off and unplugged from the mains.
- Release the 2 suitcase latches and open the door.
- Slide filters out of unit and replace with new ones.
- Close and secure door.

## SPARE PARTS

Description	Part No	L3	L4
On/Off switch	SW66	1	1
Light Switch	SW70	1	1
Light Bulb	LA08	2	2
Safety Thermostat	TH73	1	1
Centrifugal Fan	FA25	2	3
Power Cable, Plug & Lead	PL201	1	1
Suitcase Style Latch	SU15	2	2
Aluminium Grease Filter	FI11	2	3
Charcoal Filter	FI13	2	3
Foam Pad Filter	FI15	2	3

## SERVICE INFORMATION

For help with the installation, maintenance and use of your **Lincat** equipment, please contact our service department:

**☎ UK: 01522 875520**

All service work, other than routine cleaning should be carried out by one of our authorised service agents. We cannot accept responsibility for work carried out by other persons.

To ensure your service enquiry is handled as efficiently as possible, please tell us:

- Brief details of the problem
- Product code
- Type number } From serial plate
- Serial number

Lincat reserve the right to carry out any work under warranty during normal working hours, ie Monday to Friday, 08:30 a.m. – 17:30 p.m.

## GUARANTEE

This unit carries a comprehensive UK twelve-month warranty. The guarantee is in addition to, and does not diminish your statutory or legal rights.

The guarantee does not cover:

Accidental damage, misuse or use not in accordance with the instructions in these instructions

Consumable items

Damage due to incorrect installation, modification or unauthorised service work

The manufacturer disclaims any liability for incidental, or consequential damage.