

English

RAKET 120

Radne Motor AB



User Manual

Introduction

Congratulations to your choice of engine. The Raket 120 is a multi purpose engine, which you will find useful for many applications. If you read this manual before you install and start your new engine you can avoid some costly mistakes.

Keep this manual as a reference, it is a part of the complete delivery from Radne Motor AB in Sweden or our distributors.

Read carefully the safety precautions on page 5.

If you, after having read this manual, have more questions about the Raket 120 engine or the installation of it for any particular application, you are always welcome to contact Radne Motor or our local distributor. We want to make sure that every product we produce and sell will meet the expectations of our customers.

Information when contacting us:

Radne Motor AB

Box 3035
S-136 03 Haninge
Sweden

phone: +46 8 556 506 90

fax: +46 8 556 506 91

e-mail: info@radne.se

home page: www.radne.se

Rev 2, 2002-11-30

© Radne Motor AB 1998-2002

Radne Motor AB

Radne Motor AB was founded in 1967 by Leif Radne to manufacture and sell parts for gokart racing. Approx. thirty years later this is still the business idea of the company, and it is still led by Leif Radne. Radne Motor is today the leading Nordic gokart business. Radne Motor represents the leading manufacturers of tyres, chassis and personal protection, and is also producing the Raket line of engines, mainly for gokart use.

In Sweden, Radne Motor is well-known for very good service. Orders are normally shipped the same day as they arrive. The repair and service of engines and karts is done in one of the most modern kart service shops in Europe. Radne Motor is also present at most gokart racing tracks in Sweden, either through distributors or from the Radne service and spare parts van.

Over the years, more than 25.000 Raket gokart engines have been produced. They form today the basis for many classes for young drivers. Raket engines are used for racing, for rental karting or just for karting-for-fun. For whatever purpose, its owner always appreciates the extreme durability of the Raket engine.

Radne Motor has distributors in 25 countries abroad, so it is very likely that you will find one also in your country. Ask for a list of distributors. But, you can also order products and parts directly from Radne Motor. Customers abroad find it very convenient to order engines and parts via Internet, our home page is: www.radne.se

Radne Motor publishes every year a new catalogue with all the parts we sell. The catalogue also contains complete spare parts lists for most of the products we sell. In many countries Radne Motor has issued homologation forms that describe in detail all critical measures for the Raket engines. These forms are available from the national automobile sport federations.

Raket engines

The first Raket engine was introduced in 1972. Extensive research for a reliable, simple to use, yet fun to drive gokart engine at an acceptable price, had convinced Radne Motor to start the manufacture of such an engine. Power chain saw engines are the toughest two stroke engines that are built, and Radne Motor decided to build the gokart engine on well-tested vital parts. Hence, cylinder and piston, crankshaft, carburettor and ignition system were purchased. Radne Motor manufactured other parts that are typical for a gokart engine, like the aluminium crankcase. Finally, the engine was assembled and tested by Radne Motor before it was shipped. All Raket engines have been built around this concept, which has proven to be very successful.

Today the Raket line of engines consist of:

Raket 60 for the very young drivers. This engine has rope start, centrifugal clutch and forced air cooling. It can be equipped with catalytic emission control and a rev. limiter.

Raket 85 is the most popular and most produced Raket engine. It is used in many countries for the youngest drivers. Often the same engine is used with some type of power restrictor for the youngest, and later, with the restrictor removed, for the more professional drivers. The Raket 85 engine has a whole series of extras and conversion kits, so it can be used also for indoor driving and for rental kart use.

Raket 120 is used mainly for Ultra Light Aircraft, so called Paragliders. This engine is extremely powerful for its low weight. But Raket 120 has found many more uses, both for gokart and where the low weight in combination with high power and good reliability is appreciated.

Spare parts and service for the Raket engines are available from Radne Motor or from our distributors. We recommend that you consult our catalogue. A new catalogue is produced every year, in which you find the latest parts and also hints for the best use of your Raket engine.



Raket 60



Raket 85 Racing



Raket 120



Raket 120 Aero ES



Raket 120 Racing ES

Safety precautions

The Raket 120 engine is intrinsically a very safe design. If you follow these rules and general rules for machine safety, you should not encounter any risks or hazards.

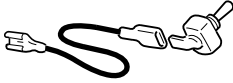

1. Always equip your engine installation with a safety switch, which will make emergency stop possible from where the engine is normally operated.

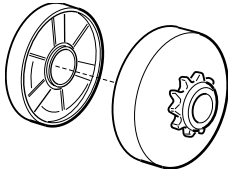

2. Always protect rotating parts with protective covers.

3. Never machine any rotating parts. It is explicitly forbidden to machine the flywheel or the clutch drum, as machining can cause them to explode.

4. Take care when you handle gasoline. It can ignite if exposed to heat or flame. Always stop the engine when you fill up with gasoline.

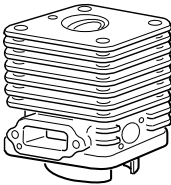

5. Cylinder and muffler become very hot, and you must protect yourself and other persons from accidental contact with hot parts. Also after the engine has been stopped, those parts remain hot for quite some time. **NOTE!** If your engine is equipped with catalytic emission control, the temperature of the catalytic converter is extremely high, also a long time after you have stopped the engine. Make sure that any contact with the muffler and the catalytic converter is impossible.

6. The exhaust fumes are poisonous and contain carbon mono oxide. Never run your engine in a confined environment. Make sure that neither you nor any other person is exposed to the fumes from the running engine.

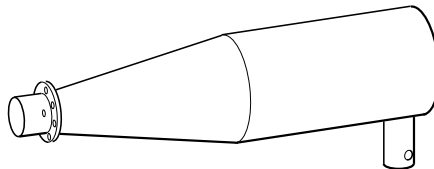

Make yourself familiar with the Raket 120 engine

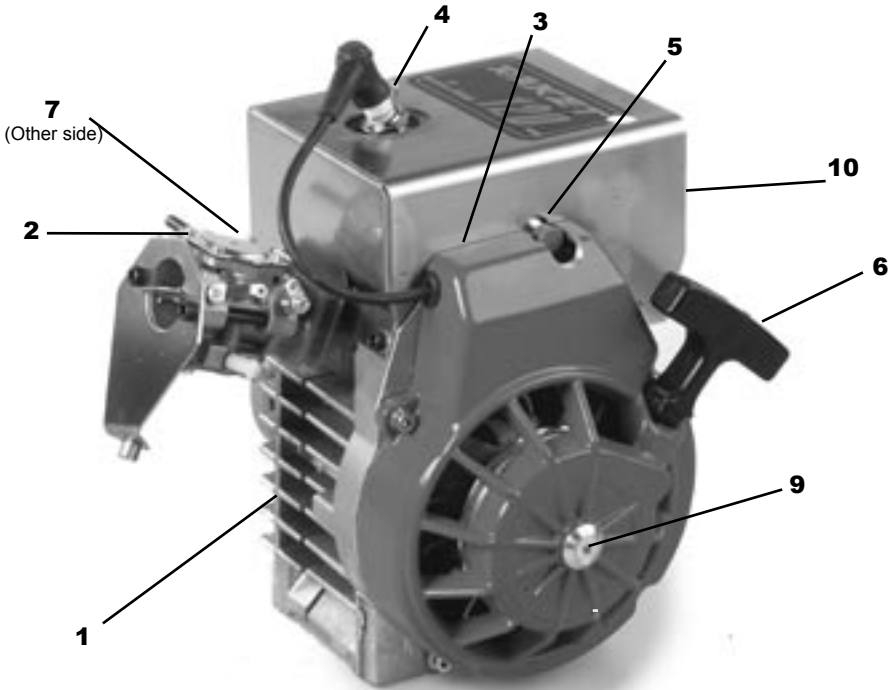

Main component	Learn about	Page
1 Crankcase, engine stand	Assembly of engine in chassi or frame	8
2 Carburettor	How to set the jets	9
3 Ignition	Electrical settings	12
4 Spark plug	Nippondenso W22MP-U	4
5 Decompression valve	How to start	12
6 Magnapul start	How to change rope	13
7 Clutch	How to maintain the clutch	14
8 Cylinder and piston	Maintenance hints	15
9 Crankshaft	Service hints	15
10 Mufflers	Different types and how to install them	15
11 Wearparts	When to change them	16
12 Preparations for start		17
13 Problems?	How to solve them	18

How to install the Raket 120 engine in a chassis or frame



For the assembly of the Raket 120 engine four threaded holes, M8, are provided in the bottom of the crankcase. For mounting the engine in a kart, a special mounting plate is available (part No 3004) with mounting clamps (part No 3005), which facilitates the assembly as well as the adjustment of the chain tension.

Note, the correct length of the M8 bolt is important. The depth of the threaded hole is 20 mm. You should make sure that, when fully inserted in the hole, the bolt uses at least 18 mm of the treaded hole, but also that the bolt is not too long to penetrate into the crankcase.

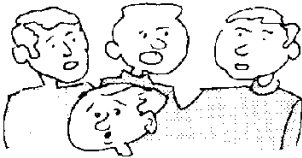

For mounting the engine in a ULA, the specifics for each ULA will determine the best mounting procedure.

The crankcase and the cover over the rope starter are made of aluminium.

You must protect all rotating parts for two reasons. First is to prevent you or another person to come in contact with a chain or shaft where you can get caught and be injured. Secondly, because of the high speed of the engine (up to 15.000 rpm) very big forces are present. If a chain or shaft should break, you must be protected against parts that can be thrown away. If you feel uncertain about the design of these protections, you should consult someone for professional help.

After you have mounted the engine to the frame or structure, you must make the following connections:

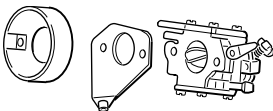

- connect the fuel tank with the carburettor inlet nipple
- connect the accelerator pedal or equivalent with the throttle of the carburettor
- connect the emergency breaker

These are all the connections needed.

The carburettor

The Raket 120 is equipped with a Walbro diaphragm carburettor of type VG6 with fixed High Speed jet.

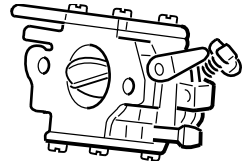

How it works

The carburettor is connected to the fuel tank with a flexible hose, made of rubber or plastic. The hose connects to the fuel inlet nipple (part No 32029 - see figure).

When you pull the starter rope and the piston moves up and down the cylinder, the pressure variations in the crankcase makes the pump diaphragm (part No 32045) move up and down. As the outer side of the diaphragm is connected to the fuel inlet nipple via two rubber valves, the movement of the diaphragm will cause a pumping action that will draw fuel from the tank to the carburettor.

NOTE! The tank and the engine shall be placed so that the carburettor normally shall suck fuel from the tank, i.e. the fuel shall not flow freely from the tank to the carburettor causing an over-pressure. Neither shall the tank be placed so low that the pump of the carburettor has difficulties in pumping the fuel from the tank.

NOTE! During normal operation the carburettor shall pump air free fuel from the tank. If, due to heavy vibrations or excessive movements of the fuel tank, you can observe that the fuel is mixed with bubbles of air (use a transparent plastic hose), this may cause the engine to loose power or to stop. If this problem cannot be solved by changing the mounting of the fuel tank, you may try to equip the fuel take off in the tank with a fuel pick up. Fuel pick ups are normally used in power chain saws, and may be obtained from most chain saw service stations.

After the fuel has passed the pump it reaches the inlet valve (sometimes referred to as the inlet needle valve - part No 32025). The normal position for the valve is closed. The valve can be opened only if the main diaphragm (part No 32017) is pressing down the lever (part No 32024). It is the amount of fuel in the main chamber that makes the main diaphragm move. When the valve is open, the fuel will flow into the main fuel chamber of the carburettor. From the main chamber the fuel can flow into the venturi of the carburettor through two jets. One jet is fixed, and controls the flow of fuel at high speed. The size of this jet is factory set and shall not be changed. If you change the fixed jet to another size you will either loose some power or your engine will run too lean and seize up.

The second jet is adjustable, it is a needle valve. It controls the flow of fuel at low speed. The normal setting of this needle valve

is one turn open from its closed position. Before you make any attempts to start the engine, make sure that the needle valve is in the "one turn open" position. Later you may open it a little further to make your engine run a little richer, or close it to make the engine run leaner.

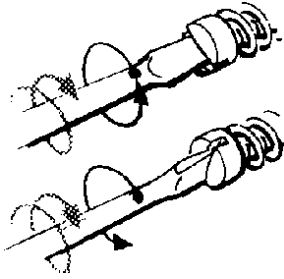

NOTE, never set the low speed valve less than $\frac{3}{4}$ of a turn open, as leaner settings may cause severe engine problems.

The carburettor is equipped with a cold start device, sometimes referred to as the choke. The purpose of the choke is to enrich the fuel during start by restricting the air flow and increasing the vacuum in the venturi. When you intend to start your Raket engine, you normally close the choke and pull the starter rope. After one or two pulls the engine will start. As the fuel-mixture with closed choke is very rich, the engine will normally stop soon. Then you open the choke, open the throttle a little and pull the starter again. Now the engine shall normally start on the first pull and run smoothly.

Installation

Apart from connecting the carburettor to the fuel tank, you also connect the lever of the throttle shaft to your accelerator pedal or other device that controls the speed of the engine. Note that on the carburettor there is an idle speed adjustment screw that allows you to set the rpm when the engine idles. The correct setting is found in combination with the setting of the low speed needle valve. When idling you shall be able to open the throttle without any tendencies for the engine to stop or stall. When you make this adjustment you normally let the engine run at a speed a little over the normal idle speed by turning the inlet speed adjustment screw a little clockwise. Adjust the low speed needle valve so that the engine responds directly when the throttle is opened, both slowly and quickly. When you have found the best setting, turn the low speed adjustment screw counter clockwise until the correct idle speed is found.

Service

Actually, there isn't much that can go wrong. If your fuel mixture is clean so no deposits clog up the interior of the carburettor you will have a problem free operation. We recommend you to change the two diaphragms and the gaskets once every year. If you haven't used your engine for some time, the diaphragms may have hardened and you may change them if you notice the engine is more difficult to start or it doesn't run smoothly at low rpms. If you are troubled with unstable operation, i.e. sometimes the engine stops at idle speed, sometimes it revs up and you have to adjust the setting of the low speed needle valve. Then, it may

be the inlet needle valve that is causing you problems, and we recommend you to change the inlet needle valve (part No 32025).

NOTE. If you find that you have problems with deposits in the interior of your carburettor due to contaminated fuel, we recommend you to install a small fuel filter in the hose between the tank and the carburettor.

If none of the hints above solve your problems, and you still have problems with low power or unstable idle speed, check the condition of all gaskets in the carburettor and between the carburettor, heat shield (part No 32065) and the cylinder. If this doesn't solve your problems, we recommend you to disassemble the carburettor from the engine and have it cleaned by Radne Motor or one of our service agents. You may also find professional help at a service station for power chain saws, snowmobiles or garden tools.

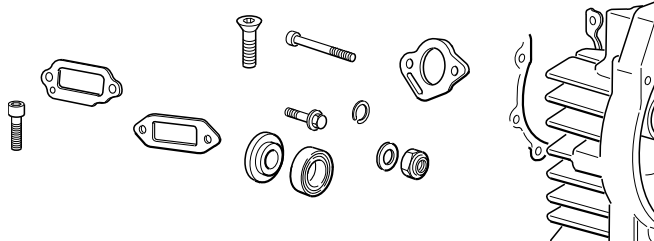

Air filter

It is strongly recommended that the Raket 120 engine is equipped with an air filter. Radne Motor has a number of different designs which all protect the interior of the engine from being damaged by sand, dust and other hard particles. See main catalogue, i.e. inlet silencer No 5201.

- the inlet noise is drastically reduced, resulting in total engine noise reduction
- improved filter action, prolongs engine life length
- protects the engine during rainy operations from being flooded with water
- can improve the engine torque curve at low speeds (depending on inlet silencer and output muffler arrangement - please contact Radne Motor for advice)



Ignition

The Raket 120 engine is equipped with a solid state ignition system, which consists of a minimum of parts.

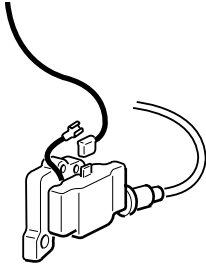

- The ignition coil with built in electronics.
- The flywheel with the permanent magnet.
- The emergency breaker = stop button.

When the flywheel rotates past the ignition coil, an electric current is generated. At a certain position of the flywheel in relation to the ignition coil, the electronic circuit, which is integrated in the coil assembly, causes the coil to produce a high tension spark for the spark plug.

As there are no moving parts, there is no setting needed. The only measure that can influence the ignition is the distance between flywheel and the yoke of the ignition coil. If you have disassembled the engine, first mount the flywheel on the shaft. Don't forget the crankshaft key. Tighten the flywheel nut with 5 kg. Then place a stainless (non magnetic) feeler gauge 0,35 mm thick between the yoke of the coil and the part of the flywheel where the pole shoes of the magnet are seen. Tighten the screws that hold the coil to the crankcase.

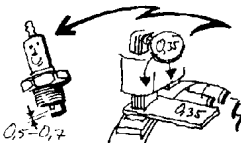

The only maintenance for the flywheel itself is cleaning. Also make sure that the starter claws near the centre can move freely.

Never attempt to make any modifications of the flywheel. If the flywheel is damaged, replace it with a new one. See also under Safety precautions.

The emergency breaker



On the coil there is an electric contact which must be connected to the emergency breaker. When this contact is short circuited to ground (i.e. to the metal parts of the engine) the ignition is stopped. Depending on application the emergency breaker can have many different designs. It is your responsibility to make sure that the breaker is placed so that it can be easily reached from the place of normal operation. On a kart it is convenient to place the stop button on the steering wheel.

Spark plug



The spark plug is a special design for this type of engine. When you replace the spark plug, make sure that you get an original part or an identical replacement. Other spark plugs can permanently and mechanically damage your Raket engine.

In original the Raket 120 engine is equipped with a Nippondenso

W22MP-U spark plug. This has the correct length of the threaded part which exactly matches the threaded part of the cylinder.

The correct distance between the centre electrode and the side electrode is 0,4 mm. This distance shall be measured with a piece of wire, 0,35 mm in diameter.

During normal operation the spark plug shall have a brownish surface on the centre electrode. However, the colour can differ a lot. If you stop the engine directly after heavy load, the centre electrode can be light grey or light brown. On the other hand, if your engine has been idling for a while before you examine the spark plug, the centre electrode may be dark brown or even black. For all the different applications that the engine has been tested for, the recommended spark plug Nippondenso W22MP-U has proven to be the best, and no "hotter" or "cooler" plug is recommended.

The normal service life of a spark plug is 200 - 300 hours. However, we recommend that you have extra spark plugs available, as e.g. repeated attempts to start a flooded engine (too rich fuel mixture) can destroy a spark plug.

The magnapull rope starter

When you intend to start the Raket 120 engine, you close the choke of the carburettor and push the decompression valve. Then you should remember two simple rules:

never just pull out the rope. Grab the rope handle and pull out the rope slowly until you feel that the starter mechanism has engaged the engine. Then you pull the rope with a powerful stroke.

never pull out the full length of the rope. Test once, slowly, to extend the full length of the rope. Notice this length, and then never pull it out so far again. Because, the life length of the starter rope is very long, subject that you don't pull it to the end. Even if the end of the rope is protected by a sleeve, it is the full extension of the rope that cuts off the knot at the end.

Service

If the rope is broken, always replace it with an original dyneemic rope with string lock (part No 3075), or at least a rope of exactly the right length (1150 mm). This is how you assemble the starter again:

first check the starter coil spring. If it is dirty, blow it or wipe it clean. Don't put oil or grease on it, unless you have special oil for coiled springs. Coil in the spring in the cassette. Put the protective washer in the bottom of the cavity for the spring, then the spring in its cassette .

take a new dynamic rope and make a knot at one end. You may find it suitable to burn the end of the rope with a cigarette lighter flame before you tie the knot, but don't burn the rope, as this will cause it to break more easily. Put the protective sleeve on the free end of the rope and slide it all the way to the end with the knot. Thread the rope through the hole in the rope disk (don't forget the string lock), you find it near the centre (see figure). Then thread the rope from the inside and out through the fan cover, and finally through the starter handle. Before you make a nice knot at the free end of the rope, remember to thread the washer that takes up the pulling force on the rope.

finally engage the slotted part of the rope disk with the inner end of the coiled spring. While doing this, make sure that the rope comes out through the opening slot at the periphery of the rope disk. Assemble the parts No 55393 and 3131 and secure the disk with screw No 55156.

Finally, grab the end of the rope that comes out through the slot at the periphery of the disk, and turn the rope disk clockwise three

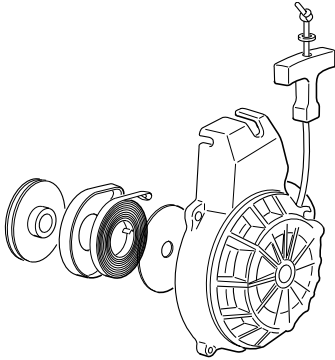

turns. Hold the rope disk with the slot adjacent to the entrance of the starter rope in the fan cover. Pull the rope by the starter handle and release the handle. The spring will now pull the rope into the fan cover. Repeat this action until all the rope is coiled into the fan cover when the starter handle is released.

The centrifugal clutch

When the engine is idling, the centrifugal clutch shall disengage the engine from whatever the engine is powering. E.g. when used to power a gokart, you release the accelerator pedal and the kart comes to a halt, the engine shall continue to run on idle speed. When you increase the rpm of the engine, the clutch shall smoothly start to pull the gokart away.

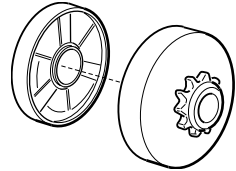

If you look at the X-ray-drawing of the engine, you will see the parts of the clutch. It consists of the hub with three spokes, three powder iron weights and three short springs. These parts are fastened to the shaft of the engine through a coarse counter clockwise (left turn) thread.

You will also find the clutch drum with the sprocket wheel for the chain. The drum can rotate on the crankshaft due to a needle bearing in the centre hole of the drum.

NOTE, a protective washer holds the needle bearing in place, see drawing for details.

NOTE, the clutch drum is made of very tough steel, which is partly heat treated. No machining what so ever on the clutch drum can be done, as this may cause the drum to explode.

NOTE, never attempt to start the engine with the clutch weights in place but without having assembled the clutch drum in place, as this will cause the springs to break and drum weights to be thrown off. The force of a drum weight can harm you lethally.

Service

To disassemble the clutch, first disassemble the fan cover. Then use the special tool that is provided for the disassembly of the clutch hub. Hold the flywheel with one hand and loosen the clutch from the shaft by turning it clockwise (Note, the thread on the shaft is counter clockwise - left turn).

NOTE, if any parts in the clutch are damaged they must be replaced with new original parts for safety reasons. Never attempt to repair any detail of the clutch by welding, brazing or machining.

When you assemble the clutch, put some heat resistant grease, like graphite grease, on the needle bearing.

Cylinder and piston

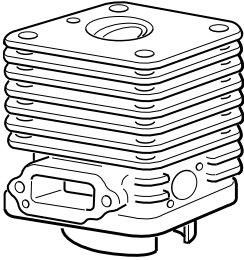

The cylinder has a permanent coating in the bore that will last the life of the Raket engine. The piston is made of aluminium and will under normal conditions have a life time of 500 hours. The difference between long and short life for the piston is determined by the type of inlet air filter that is used.

The piston is equipped with two piston rings, each 1,5 mm thick. They have a life time of 200 hours under normal running conditions.

On the top of the pistons there is a marking showing which part of the piston that shall face the exhaust port.

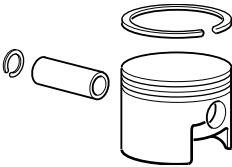

New pistons are only available in one dimension as spare parts. This has been made possible due to the extreme tolerances of the cylinders and the pistons.

When replacing piston or piston rings, make it a good rule also to replace the small end needle bearing and the cylinder foot gasket.

Crankshaft

The crankshaft with connecting rod and connecting rod needle bearing is one unit, and we don't recommend any attempts to repair this unit.

The bearings on the crankshaft are SKF 6203 C 3. This bearing cannot be replaced by any standard bearing. (Larger radius of the inner ring). When you disassemble the crankcase, the bearings should normally sit on the shaft.

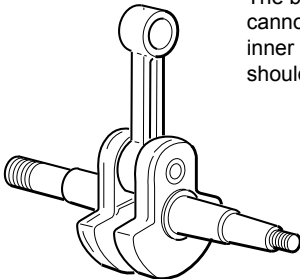

Mufflers

Raket 120 can be delivered different muffler arrangements.

The Power Exhaust Muffler consists of three parts:

- . the exhaust tube that is bolted to the cylinder
- . the flexible hose that connects the exhaust tube with the muffler, and
- . the tuned muffler (with or without emission control)

The three parts of the Power Muffler have been tuned to give the best (highest) output, and we advise against the change of any of the three parts. If you reduce the diameter of the tubes or the volume of the end muffler, you will loose power. If you shorten the length of the flexible hose, the torque curve of the engine will show lower values at lower speeds.

Catalytic emission control

At Radne Motor we take pride in the care of our environment. For this reason we recommend the use of a catalytic exhaust converter, and all our mufflers can be delivered with or without a converter.

NOTE, a muffler with catalytic converter will be much hotter than one without. So, when your engine is equipped with catalytic converter, take special care to protect the muffler from accidental contacts.

NOTE, a muffler with converter cannot be repaired. If damaged it has to be replaced.

NOTE, don't throw away a muffler with catalytic converter. Find out where in your community you can safely deposit your used catalytic mufflers.

NOTE, always use lead free gasoline, as gasoline with lead in will momentarily destroy your muffler.

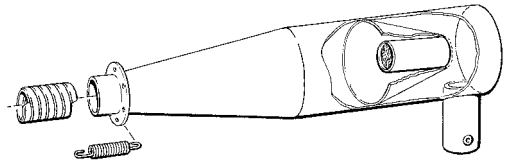

Wearparts and service intervals

The Raket 120 will need very few spare parts due to its simple and reliable design. The table below shows some typical service intervals. Please notice that the conditions under which the engine is operated will have great influence on these intervals.

Every 200 hours

- piston rings

Every 300 hours

- spark plug
- centrifugal clutch drum and weights (if the drum shows sign of wear on the inside of the drum)

Every 400 hours

- piston
- small end connecting rod needle bearing
- main roller bearings
- sealing rings
- gaskets

How to mix gasoline and oil for proper fuel

Every engine needs oil to lubricate cylinder and piston, and all the different bearings and sealings. In a four stroke engine the oil is normally kept in the crankcase and pumped around to where it is needed.

Raket 120 is a two stroke engine, and two stroke engines don't have any separate oil for lubrication. As oil still is needed, the oil is mixed with the gasoline, and thus follows the fuel in and around in the whole interior of the engine. If you would attempt to run the Raket 120 engine on fuel with no oil in it, the engine would break down due to the internal friction between cylinder and piston. For this reason it is important that you always use a gasoline and oil mixture as fuel.

The Raket 120 is designed to run on a mixture of 4 % (per cent) synthetic oil in lead free gasoline, 95 or 98 octane.

NOTE. If you have your engine equipped with catalytic emission control (catalytic converter) you **MUST** use lead free gasoline. If you don't have a catalytic converter, you could use leaded gasoline, but we still recommend the unleaded types, preferable with 98 octane, but 95 will also do.

How to get 4% oil mixture:

Use a clean can or fuel container. Mix 10 liters of fuel with 0,4 liters of synthetic oil. Shake well! Your gas station can offer you a variety of two stroke oils. We recommend the type that is used for chain saws, lawn movers and smaller motorcycles. Two stroke oil for marine use is called outboard oil, and is not recommended depending on the extra ingredients for corrosion control.

Don't use so called racing oil, sometimes also called castor oil. This type of oil mixes not so well with the gasoline, and may later separate in the tank.

Environmental fuel

In some countries fuel for lawn movers, garden tools, chain saws etc is made from other raw materials than oil. The advantage of these fuel products is that they produce less of exhausts that pollute the environment. Before you use a fuel of this kind, make sure with the manufacturer that you can do so without harm to your Raket engine. Also get the recommendation from the manufacturer to the percentage of synthetic oil mixture that corresponds to 4 % of oil in normal gasoline.

Radne Motor AB takes no responsibility for damages that may occur due to use of improper types of fuel and oil.

Preparations for start

- 1 Check the condition of the engine installation. Does the throttle operate well? Is the emergency breaker correctly connected? Is the flexible hose from the tank to the carburettor fastened so it will not break?
- 2 Is there enough gasoline in the tank?
- 3 Close the choke and push the decompression valve.
- 4 Grab the starter handle. Pull out the starter rope until you feel that the starter has engaged the engine, and then pull out the rope, avoiding to pull it to the fully extended length.
- 5 Observe the transparent fuel hose and note if gasoline is drawn from the tank to the carburettor.
- 6 Repeat until you are sure that gasoline has entered the carburettor.
- 7 Check that the emergency breaker is in the OFF (running) position.
- 8 Pull the starter again, until you hear that the engine starts (ignites). It is quite normal that the engine just rotates a few turns and then stops again due to the very rich mixture with the choke closed.
- 9 Open the choke.
- 10 Pull the starter again. Now the engine shall normally start and run at idle speed.
- 11 If the engine starts but stops again, you may open the throttle just a little to increase the speed of the engine just after start. After a few seconds at increased idle speed, the engine shall run at normal idle speed.

NOTE, if you equip your engine with an arrangement that allows you to lock the throttle in "increased idle speed position", this may result in that the clutch engages when the engine starts. Make sure that this has no harmful effect, e.g. that your karts start to move away from you.

How to stop the engine

Put the emergency breaker in the ON (stop) position

Engines with integrated electric start

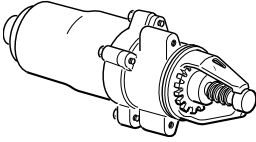

Technical data for electric start:

Part.No	Description
32156	Start engine FIAM 0,25 kW
32076	Ignition system SELETRA
78013	Battery 12 V, 7,5 AH
32170	Decompression valve, automatic

RAKET 120 Racing ES is always supplied with complete cables and battery. To be assembled as per wiring diagram.

RAKET 120 Aero ES is always supplied without cables and battery, depending on different applications.

Always use a cable with a min. diameter of 4 mm². Also always use a start switch of high quality, so that no sparks occur.

The stop switch shall be connected to the ignition system so that the engine stops when earthen.

The battery is not charged via the engine, but has to be charged through a separate battery charger. E.g. our automatic battery charger (N.B. only for lead batteries), art.No 7817.

The engine can be started approx. 150-200 times with our battery of 7,5 AH, without recharging the battery. It is very important to choose right size of battery depending on how many times you need to start the engine.

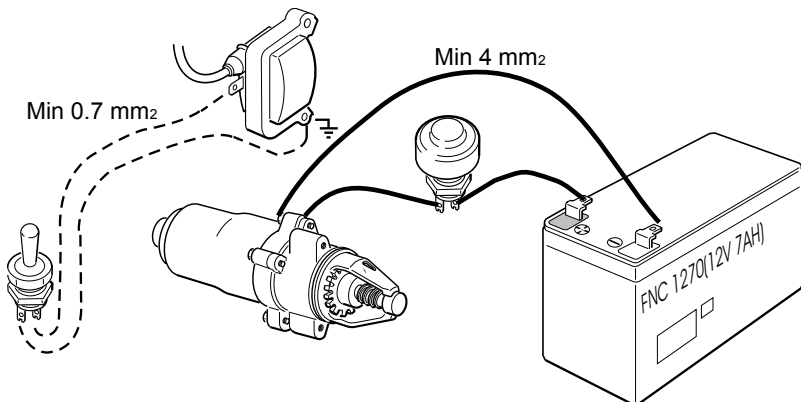

Troubleshooting

Problem

No fuel is drawn from the tank to the carburettor

Check

Check that there is fuel in the tank
Check for leaks in the fuel hose or its connections.
Check if the inlet needle valve in the carburettor is stuck. You can open it by pressing down the main diaphragm with a 3 mm wire through a hole in the cover over the main diaphragm
Change the carburettor pump diaphragm and the gasket

Carburettor is pumping fuel OK, but engine doesn't start. Spark plug is wet.

Check the inlet needle valve function. Is the valve stuck in open position? Is the inlet needle valve spring broken? Replace inlet valve and spring when necessary

Carburettor is pumping fuel OK, inlet valve is OK, but engine won't start

Check setting of low speed jet. Normal setting is 1 turn open from closed position
Clean inside of carburettor

Engine starts, but won't run at high speed

Check if high speed jet is open. Clean jet if necessary

Engine won't start, no spark in the spark plug

Change the spark plug

No spark even after change of spark plug

Check emergency breaker circuit. In OFF (running) position the contact on the ignition coil must not be connected to ground

Emergency breaker circuit OK, but still no spark

Change the complete ignition unit (ignition coil)

Carburettor seems OK, but engine power is reduced and engine runs erratically

Check piston rings. Normal service life is 200 hours, but can be reduced if no proper air filter has been used
Check crankshaft sealing rings. If rings are leaking, operation at both low and high speed is affected

If the start sprocket doesn't react

Too low power voltage in the battery or too small diameter of the cable.

If the engine starts and then stops immediately

Can depend on dirt in the decompression valve or in the reverse valve on the vacuum hose to the cylinder

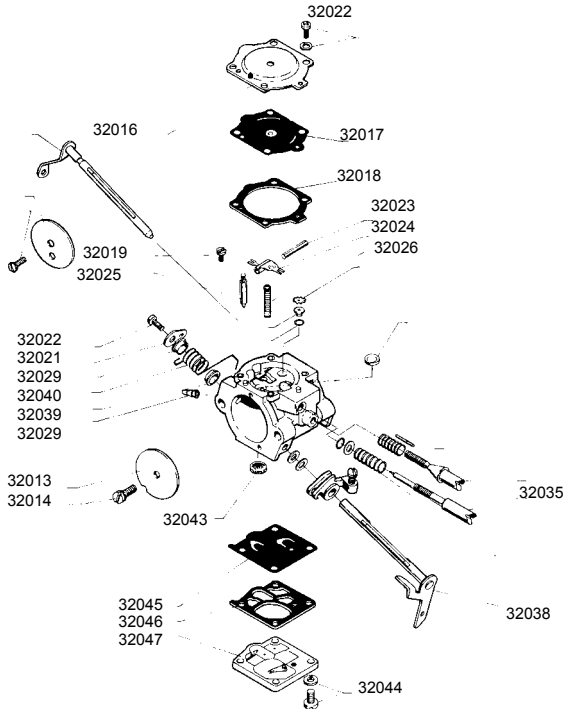

32013	Plate	32038	Trottleshaft
32014	Screw	32039	Bushing
32015	Chokeaxle	32040	Spring
32016	Cap	32042	Filter small
32017	Main diaphragm	32043	Filter
32018	Gasket	32044	Screw
32019	Screw	32045	Diaphragm
32020	Expansion cap	32046	Gasket
32022	Screw	32047	Pump cover
32023	Axle	32155	Gasketset for carburettor
32024	Lever		
32025	Valve		
32026	Spring		
32027	Expansion cap		
32028	Sirclip		
32029	Fuel elbow		
32031	High speed mixture screw		
32032	Spring		
32035	Low speed mixture screw		
32036	Spring		
32037	Screw		

Raket 120 Manual Start

3007	Spring 40 mm	32147	Needle bearing clutch drum
3010	Flex	32151	Crank case gasket
3012	Silencer	32152	Decompression valve
3012-1	Silencer Catalytic converter	4118	Flywheel nut
32048	Carburettor Walbro	5203	Carburettor flange
3053	Exhaust gasket	55140	Screw allen key 5 x 45
3054	Screw 5x25	55142	Screw allen key 5 x 50
3055	Sparkplug	55167	Screw allen key countersunk 6 x40
3056	Sparkplug cap	55109	Screw allen key 4 x 20
32063	Carburettor gasket	55126	Screw allen key 5 x 20
32065	Flange	55129	Screw allen key 5 x 25
32066	Inlet gasket	55156	Screw allen key 6 x 22
3075	String lock	55392	Countersunk washer
3076	Ignition System	55393	Countersunk washer 6 x 25
3077	Ignition cable	55405	Washer M4
3099	Oil sealing sprocket side	55412	Washer M8
3136	Washer fiber		
3152	Start hook		
3153	Spring start hook		
3154	Spacer start hook		
3158	Rubber bushing		
32085	Cylinder complete		
32086	Pistonring		
32087	Piston complete 120 cc		
32090	Cylinder gasket		
32091	Small end bearing		
32092	Crankshaft		
32093	Mainbearing SKF 6203		
3095	Key		
3099	Oilsealing drive side		
3119	Stop switch		
3120	Stop cable		
3131	Axle string disc		
3132	Exhaust bend		
3133	Starhandle		
3134	Stringdisc		
3135	Magnapull spring		
31371	Start coat		
3138	Start string		
31391	Start coat complete		
32116	Flywheel		
32126	Cylinder cover		
32143	Clutch		
32144	Clutch drum 12 t		
32144-1	Clutch drum 11 t		
32144-2	Clutch drum for aero		
32148	Spacer for clutch		
32150	Crankcase		
32163	Exhaust nut		
32049	Throttle cable support		

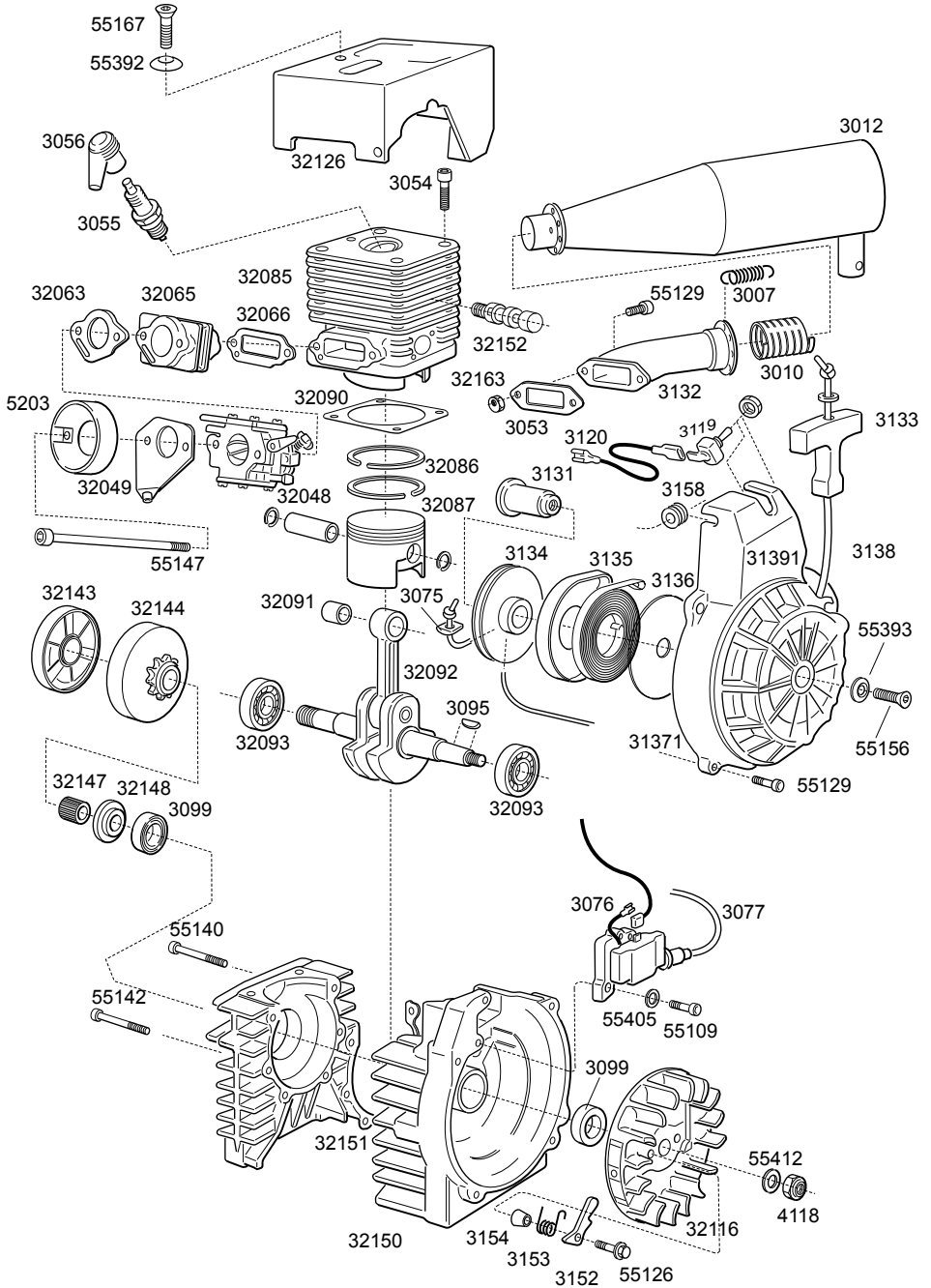

Raket 120 Electric Start

3007	Spring 40 mm	5203	Carburettor flange
3010	Flex	55124	Screw allen key 5 x 12
3012	Silencer	55129	Screw allen key 5 x 25
3012-1	Silencer Catalytic converter	55135	Screw 5x25
3029	Elbow, vacuum connection	55140	Screw allen key 5 x 45
3053	Exhaust gasket	55147	Screw allen key 5 x 50
3054	Screw 5x25	55161	Screw allen key 5 x 45
3055	Sparkplug	55165	Screw allen key 6 x 40
3056	Sparkplug cap	55412	Washer M8
3099	Oil sealing	7813	Battery
3095	Key		
3119	Stop switch		
3132	Exhaust bend		
32063	Carburettor gasket		
32065	Flange		
32066	Inlet gasket		
32048	Carburettor Walbro		
32059	Fan cover		
32063	Carburettor gasket		
32065	Flange		
32066	Inlet gasket		
32076	Ignition System		
32089	Sirclip piston		
32085	Cylinder complete		
32086	Pistonring		
32087	Piston complete 120 cc		
32090	Cylinder gasket		
32091	Small end bearing		
32092	Crankshaft		
32093	Mainbearing SKF 6203		
32049	Throttle cable support		
32112	Start button		
32116	Flywheel		
32143	Clutch		
32144	Clutch drum 12 t		
32144-1	Clutch drum 11 t		
32144-2	Clutch drum for belt-drive		
32147	Needle bearing clutch drum		
32148	Spacer for clutch		
32151	Crank case gasket		
32153	Crankcase		
32156	Start engine complete		
32159	Start sprocket		
32160	Hub start sprocket		
32163	Exhaust nut		
32170	Decompression valve automatic		
32171	Valve bushing		
32172	Valve tube		
32175	Bushing for cover		
4118	Flywheel nut		

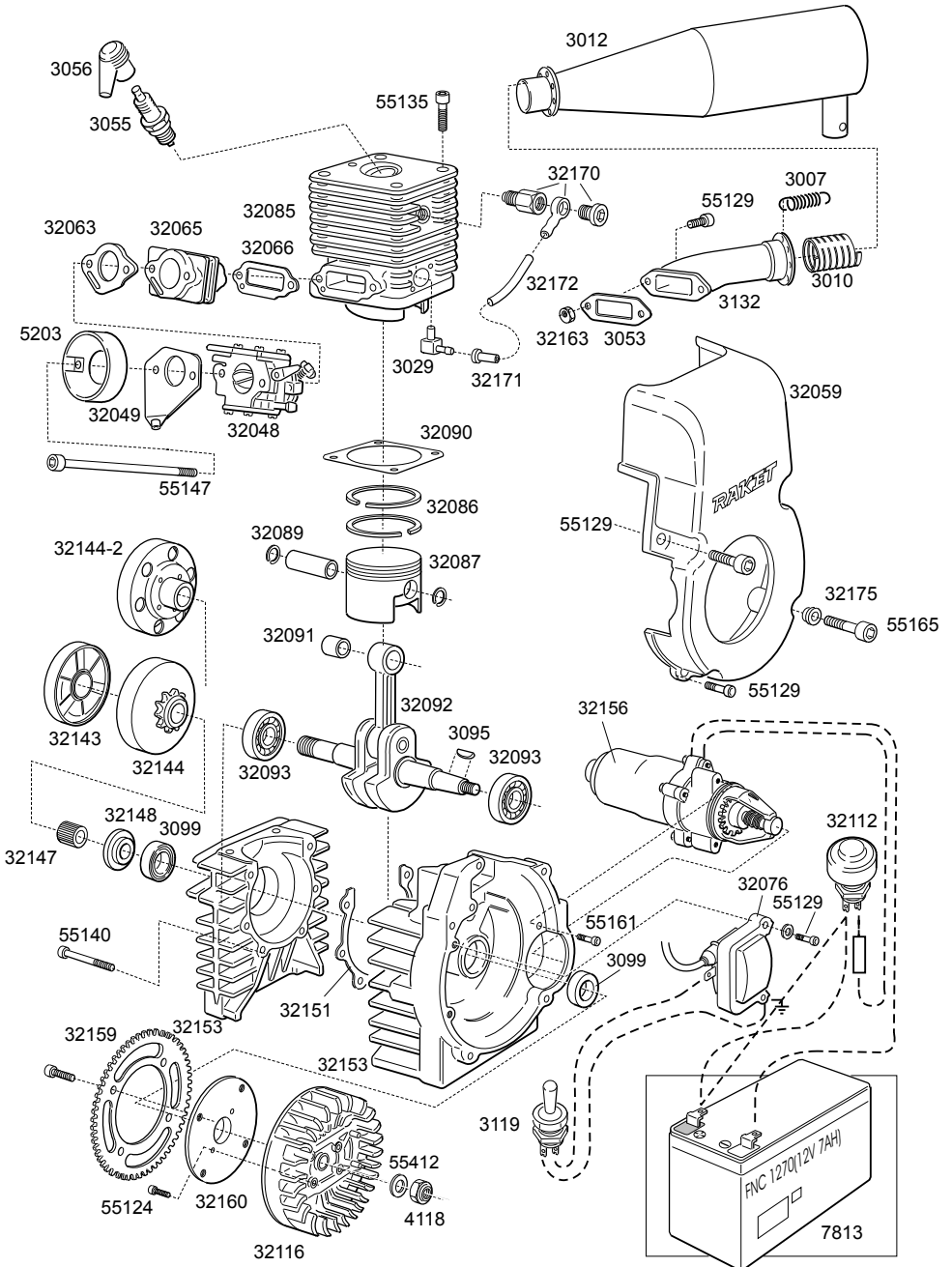

Radne Motor AB, Box 3035, 136 03 Haninge, Sweden

Tel: +46-8-556 506 90, Fax: +46-8-556 506 91

info@radne.se

<http://www.radne.se>