

# **OPERATION & INSTRUCTION MANUAL**

(3kW – 12kW Steam Generator & Control Panel)

## Table of Contents

### **Part 1: Steam Generator**

Safety Warnings .....	2
Safety Warnings in French.....	3
Users Instructions .....	4
Choosing a proper location .....	4
Steam equipment installation diagram .....	5
Installation of the pipeline .....	5
Steam Generator blueprint .....	8
Electric requirements .....	10
Power line assemble illustration .....	11
Wiring Diagram 380-415V (3PH) .....	12
Wiring Diagram 208V (3PH) .....	13
Wiring Diagram 220-240V (1PH/2PH) .....	14
Installation of the top light.....	15
Choose your type of machine .....	16
Steam generator configuration .....	17
Troubleshooting guide .....	18
Specification .....	19

### **Part 2: Control Panel**

Control Panel blueprint .....	20
Controller Installation instruction .....	21
Temperature detector installation.....	22
Controller Panel Illustration .....	22
Operating instructions .....	23

**\*\*\*SAVE THESE INSTRUCTIONS!**

**READ AND FOLLOW ALL INSTRUCTIONS.**

**\*\*\**Ces instructions sont à conserver soigneusement!***

**ETUDIER ET ENSUITE SE CONFORMER À TOUTES  
LES INSTRUCTIONS**

**WARNING!**

*To reduce the risk of injury, do not permit children to use this product unless they are closely supervised at all times.*

**WARNING!**

To reduce the risk of injury:

- a. *The wet surfaces of steam enclosures may be slippery. Use care when entering or leaving.*
- b. *The steam head is hot. Do not touch the steam head and avoid the steam near the steam head.*
- c. *Prolonged use of the steam system can raise excessively the internal human body temperature and impair the body's ability to regulate its internal temperature (hyperthermia).*

**WARNING!**

*Hyperthermia occurs when the internal temperature of the body reaches a level several degrees above the normal body temperature of 98.6° F. The symptoms of hyperthermia include an increase in the internal temperature of the body, dizziness, lethargy, drowsiness, and fainting. The effects of hyperthermia include:*

- a) *Failure to perceive heat;*
- b) *Failure to recognize the need to exit the steam bath;*
- c) *Unawareness of impending risk;*
- d) *Fetal damage in pregnant women;*
- e) *Physical inability to exit the steam bath; and*
- f) *Unconsciousness.*

**WARNING!**

*The use of alcohol, drugs, or medication can greatly increase the risk of hyperthermia.*

*Limit your use of steam to 10 – 15 minutes until you are certain of your body's reaction.*

*Excessive temperatures have a high potential for causing fetal damage during the early months of pregnancy. Pregnant or possibly pregnant women should consult a physician regarding correct exposure.*



**Caution:** Do not place wire in close proximity to hot water or steam pipes.



**Attention:** *If the installation and operation instruction are not read or understood, do not install. Install the controller based on the installation instruction.*

*If the controller is installed outside the steam room, the temperature sensor must be installed in the steam room. To prevent overheating, operate the controller as described in this manual only.*

**\*\*Not for Space Heating Purposes**

## **DANGER!**

*Afin de réduire les risque de blessures, ne jamais autoriser des enfants à utiliser ce appariel, sauf s'ils sont étroitement surveillés, à tout moment*

## **DANGER!**

- a) *Les cabines où de la vapeur est introduite peuvent comporter des surfaces humides et donc glissantes. La plus grande prudence est de rigueur au moment où l'utilisateur pénètre, ou quitte la cabine*
- b) *La tête d'injection de la vapeur est à haute temperature; il faut veiller à ne pas entrer en contact avec cette tête d'injection. De plus, il faudra éviter le contact avec le jet de vapeur à proximité de la tête d'injection.*
- c) *Soumis, d'une manière prolongée aux températures occasionnées par un jet de vapeur, la température interne du corps humain est susceptible de dépasser le seuil où celui-ci s'auto-régule, provoquant l'hyperthermie.*

## **DANGER!**

*Le corps humain enter en hyperthermie quand sa température interne dépasse de plusieurs degrés sa temperature normale de 98.6° Fahrenheit, soit 37°Celsius.*

*La personne en état d'hyperthermie souffre d'étourdissements, est léthargique, assoupie et susceptible d'évanouissement.*

*Les effets de l'hyperthermie comportent:*

- a) *Insensibilisation à la chaleur*
- b) *L'absence de volonté de quitter le local sous temperature élevée*
- c) *Inconscience du danger imminent*
- d) *En ce qui concerne les femmes enceintes, la possibilité de réactions nocives au niveau du fœtus. Les femmes enceintes, ou potentiellement enceintes, doivent préalablement consulter un médecin*
- e) *Engourdissement physique menant à l'incapacité de quitter le local*
- f) *Perte de connaissance*

## **DANGER!**

*L'usage de drogues, d'alcool, de médicaments est susceptible d'augmenter les risques d'hyperthermie dans de larges proportions.*

*Avant utilisation, il y a lieu de limiter votre usage de la vapeur à 10-15 minutes pour tester les réactions de votre corps.*

*Pendant les premiers mois de grosses, des températures excessives sont susceptibles d'engendrer des dommages, à issue fatale, au fœtus. Les personnes enceintes, ou probablement enceintes, doivent obtenir un avis médical en ce qui concerne les conditions auxquelles elles peuvent se soumettre.*

## **Avertissements**

- Ne pas installer de fils à proximité d'eau chaude ou de conduits de vapeur
- La tête d'injection de vapeur ainsi que l'orifice de débit de vapeur sont à hautes températures – Eviter le contact de ces appareils sous peine de brûlures.
- Cet appareil ne doit pas être utilisé à de fins de chauffage ambiant
- Avant toutes opérations de maintenance et de nettoyage, déconnecter la source de courant

## **Installation**

- Installer la tête d'injection de vapeur enter 15 et 30 cm au-dessus du sol. Si le bain de vapeur se trouve dans la baignoire ou la salle de bains, installer la tête d'injection de vapeur à 15 cm au-dessus de la baignoire

*Le jet de vapeur doit être dirigé vers le bas. Entourer le filet du tuyau de vapeur de quelques couches de Teflon, visser la tête d'injection de vapeur et visser manuellement.*

# Part 1: Steam Generator

## User instructions



**Attention:** *We are not responsible for the malfunction and damage from improper installation that does not comply with the user's manual.*

1. Make sure the model and the accessories are correct, including the voltage input.
2. Make sure the steam power is matched with the dimensions of the sauna room. Pay attention to the steam room's cubic feet measurements and construction materials. If you have any problems, please refer to the Page 11 to get the correct information.
3. Make sure to read this manual carefully for correct and effective use.
4. We shall not be responsible for the product damage or malfunction caused by self-installation or the operation procedures which is not in compliance with the Operation and Instruction Manual.
5. Please check the contents when the package arrives to assure it is in good condition. If you find any damage in the package, please contact the transportation company or the supplier to claim any damage.
6. This product must be used indoors.

## Choosing proper location

Recommended locations for proper installation:

1. The steam box should not be located further than 16 feet away from the steam room.
2. The steam generator should not be installed in the steam room.
3. The steam generator should not installed outdoor or in any places that will influence the security of the machine.
4. Do not install it in any places where the water might freeze.
5. Do not install near flammable objects or chemicals (coal, gas, etc.)
6. The steam generator should be installed in a dry and ventilated place.
7. Make sure the steam generator is secured on the wall and is in horizontally positioned.
8. On the other three sides, there has to be minimum of 12inches of space left between steam generator and any other object.
9. The place where the machine is installed must be accessible for cleaning and possible service work.
10. The steam generator should be in a close proximity to a drain for convenient Water Drain Valve hook-up.
11. After use, the steam pipe, safety valve, drain valve, water pipe, steam outlet is still very hot.
12. Place steam outlet away from bathers.

**Attention:** *install an exhaust fan outside of the steam room so that it can expel any excess steam for proper ventilation.*



**Attention:** The steam generator (including the controller) are UL approved.

## Installation drawing of the steam generator

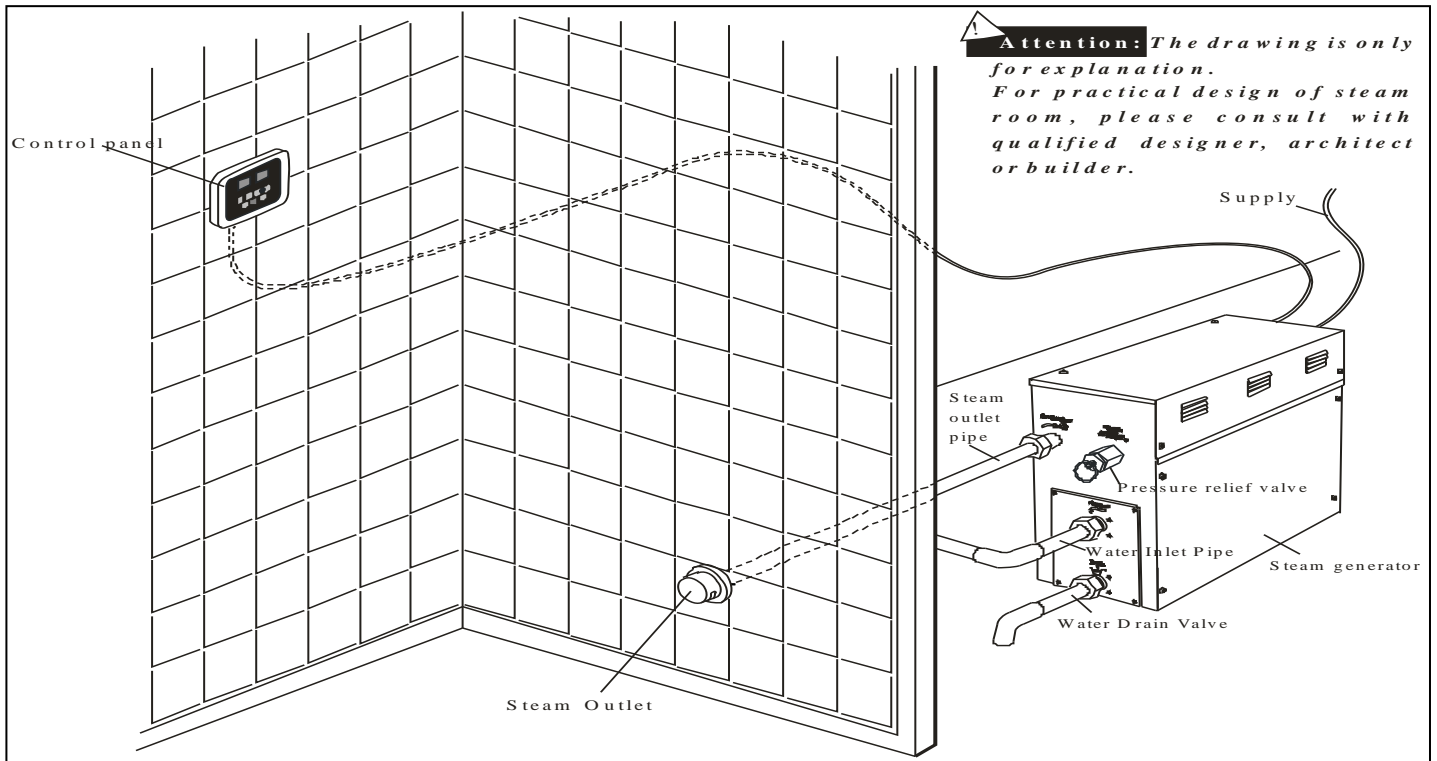

## Installation of pipeline



**Attention:** The installation of all the pipes should be completed by qualified plumbers or technicians.

1. Use brass or copper pipes only.
2. Do not use black, galvanized or PVC pipes.

### Water supply pipe (1/2")

1. Connect cold water pipe to water inlet.
2. Install shutoff valve in the water supply pipe. The shutoff valve should be installed in a place where it is easily operated in case of emergency.
3. Clean the water supply pipe completely before connecting it to the steam engine.
4. It is suggested that a water filter should be installed in the water supply pipe.
5. The water pressure should be no less than 20 pounds/square inch (psi), and no more than 75 (psi). If necessary, decrease or increase the pressure accordingly.

Steam pipe (3kW/4.5kW pipe size: 1/2"£6kw & above:3/4")

1. Do not install any valves in the steam pipes. The steam can never be obstructed.
2. Install a brass or copper steam pipe(3kW/4.5kW pipe size: 1/2"£6kw & above:3/4") as connector between the steam outlet and the steam nozzle.
3. The heat insulation material used to insulate the steam pipe should be resistant to temperature as high as 248oF or higher.
4. Do not bend the pipe so that the cooled water will not stay in the curve of the steam pipe.
5. The shorter the steam pipe, the better. Try to decrease the number of elbows and avoid abrupt turns.
6. Have no valleys or dips in the output steam line.
7. Do not install a valve in the steam line.
8. Do not connect the drain valve into the steam line.
9. Do not connect the over-pressure device output into the steam line.

Steam nozzle (3kW/4.5kW pipe size: 1/2"£6kw & above:3/4")

### **WARNING!**

The steam nozzle and steam outlet are very hot! Avoid installing the steam nozzle near steam bathers.

1. Install the steam nozzle 6-12 inches above the ground. If the steam bath is in the bathtub or bathroom, install the steam nozzle 6 inches above the bathtub.
2. The steam spray outlet should be installed face down. Wrap a few circles Teflon tape around the threads of the steam pipe, install the steam nozzle and tighten with hands.

### **DANGER!**

1. Installer la tête d'injection de vapeur enter 15 et 30 cm au-dessus du sol. Si le bain de vapeur se trouve dans la baignoire ou la salle de bains, installer la tête d'injection de vapeur à 15 cm au-dessus de la baignoire
2. Le jet de vapeur doit être dirigé vers le bas. Entourer le filet du tuyau de vapeur de quelques couches de Teflon, visser la tête d'injection de vapeur et visser manuellement



**Attention:** *In order to protect the steam nozzle, do not use any tools to tighten that will scratch finish, use a little soap water and soft sponge to wipe, and do not use erosive chemical solutions or abrasive cleaning tools.*



**Attention:**

Please consult your distributors of building materials like acrylic, fiber glass or other heat resistant sheet about the installation and position of steam nozzle. It is suggested that MS-103412 heat resistant material is used.

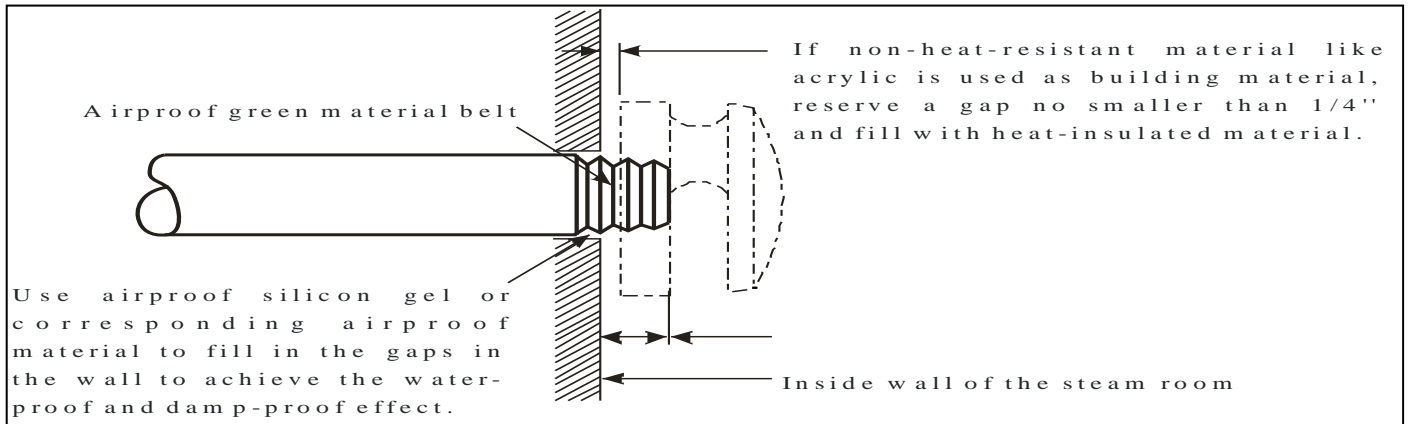

**Drainpipe (1/2")**

According to national and local codes, the steam engine drain valve should be equipped with drainpipe. The steam engine will drain water on its own.



**Attention:** drainpipe should not incline upwards.

**Safety valve**

1. Safety valve is to prevent too much steam pressure in the interior steam engine.
2. The pressure limit range of safety valve is 15PSI and the pressure will begin to decrease if pressure should come over this value.
3. Provide the safety valve with exterior drainpipe.



**Attention:**

1. For safety, do not dismantle the pressure decrease valve at random.
2. To maintain the proper and automatic operation of safety valve, make sure the safety valve connection pipe is smooth.



# Blueprint for the steam engine

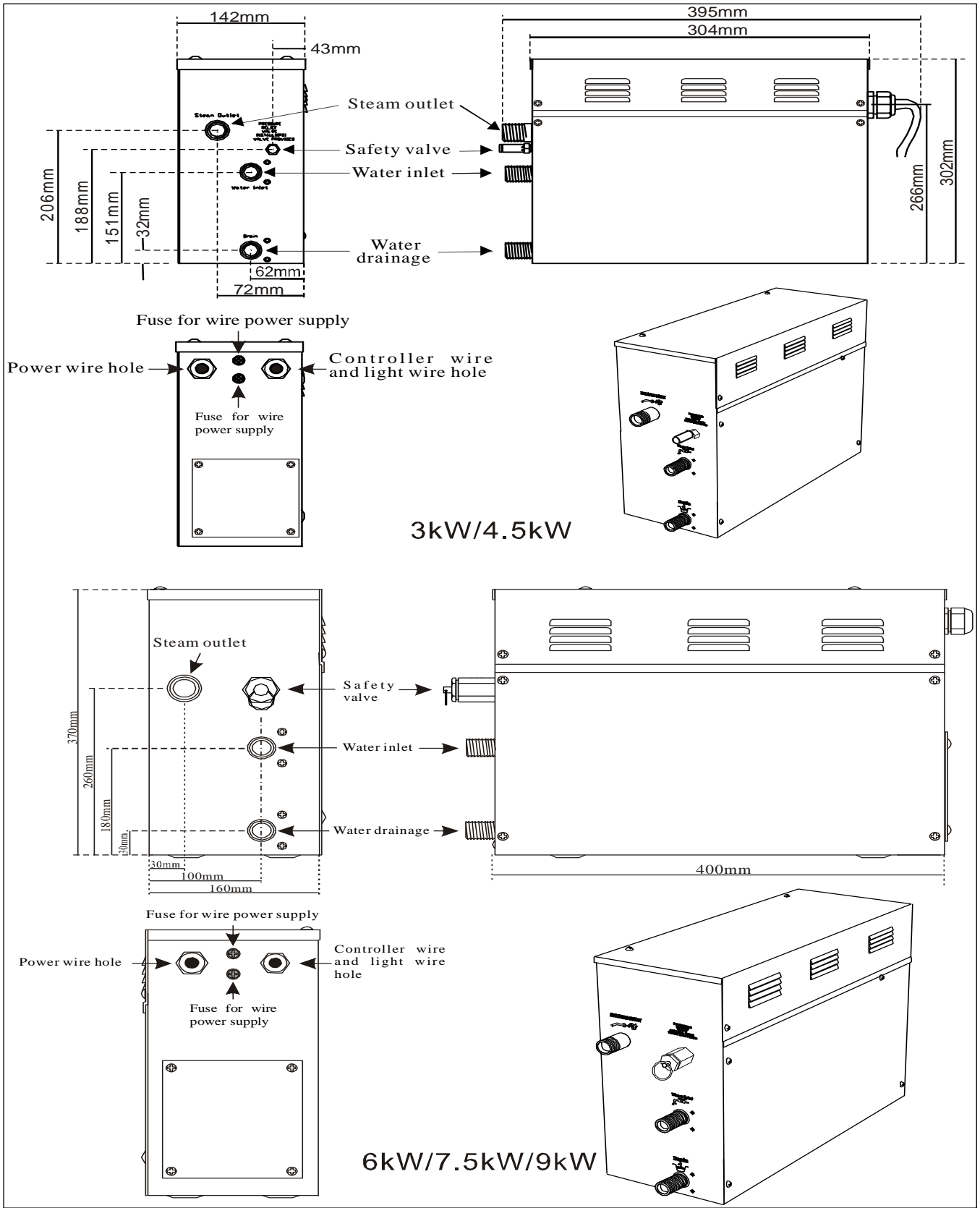

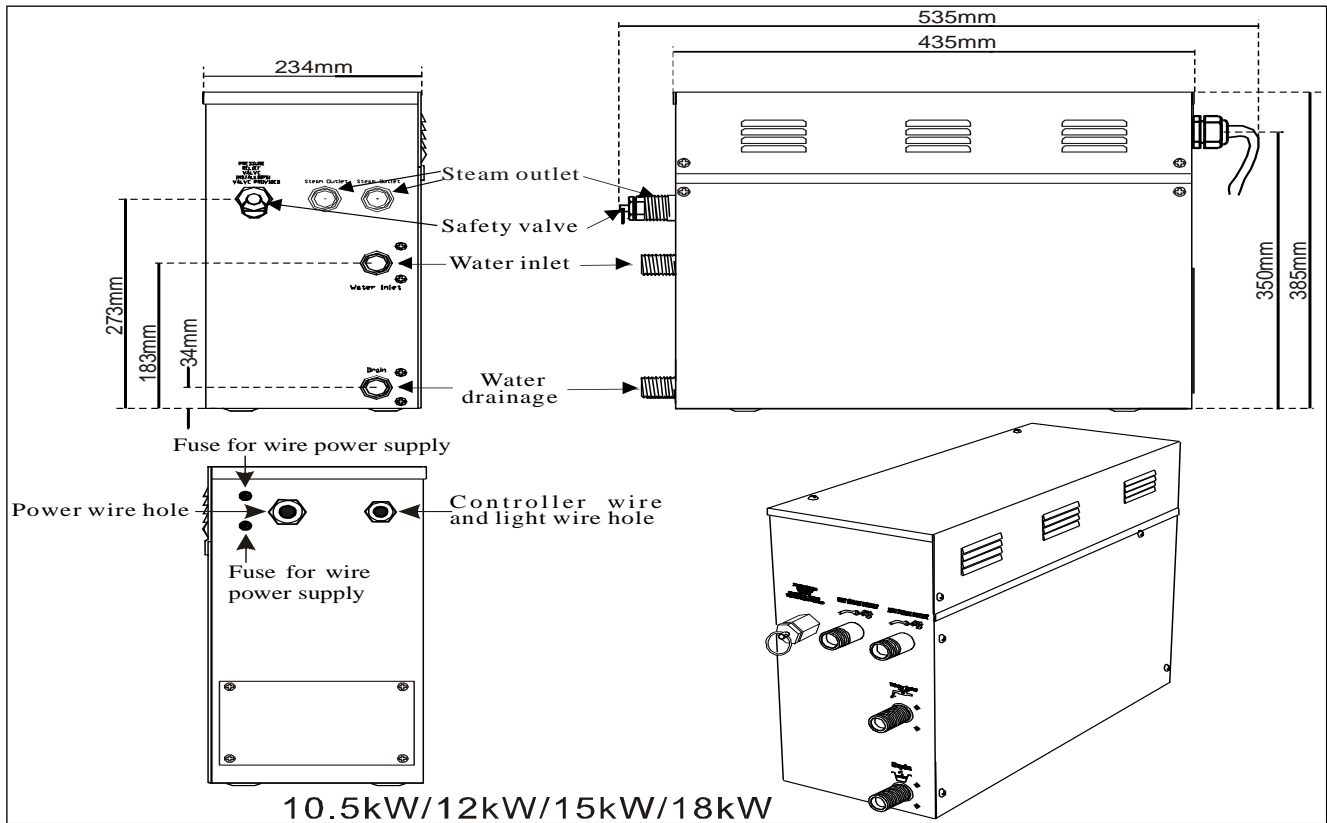

**Attention:** Keep the steam engine clean.

**Attention:** To avoid damage to the equipment, do not connect strong electrical current directly to the components.

**IMPORTANT:** Each unit shall be provided with a pressure-release device to address overpressure due to inadvertent blockage of the output steam head or piping. If factory installed, it shall be provided with no more than 6 inches (150mm) of piping between the device and the generator tank. If shipped with the steam generator, the installation instructions shall indicate it shall be installed to the generator tank with no more than 6 inches (150 mm) of piping.

### **Electrical requirements:**

Electricity supply circuitry:

1. Test the voltage of the electric supply and make sure that the steam engine with suitable electric voltage is used.
2. Insulated copper wire should be used with a heat resistant temperature of 194oF and a specified voltage of 500V. Refer to national or local electricity consumption code for the specifications. Refer to the ammeter for the ampere.
3. Choose steam engine with suitable item number, and plug the ground wire into the ground terminal.
4. Install an independent GFCI circuit breaker between the power supply and the steam engine so as to provide an electric supply with overflow protection and electricity leakage protection.

**Important:** All the connections must be in accordance with national and local electricity code and be installed by professional electricians.

### **Ampere Meter**

Type	Applicable space of the room (m <sup>3</sup> )	Electricity supply	Max. Electrical current (A)	Specifications for power wire ( A W G)
GS08-3kW	3~6	220-240V / (1PH/2PH)	13.7A	12# or 2.0mm <sup>2</sup>
GS08-4.5kW	4~7	220-240V / (1PH/2PH)	20.5A	12# or 4.0mm <sup>2</sup>
GS08-6kW	5~8	220-240V / (1PH/2PH)	27.3A	10# or 6.0mm <sup>2</sup>
		208V / (3PH)	16.7A	12# or 4.0mm <sup>2</sup>
		380-415V / (3PH)	9A	12# or 2.0mm <sup>2</sup>
GS08-7.5kW	7~9	220-240V / (1PH/2PH)	34A	8# or 6.0mm <sup>2</sup>
		208V / (3PH)	21A	10# or 4.0mm <sup>2</sup>
		380-415V / (3PH)	11.4A	12# or 2.0mm <sup>2</sup>
GS08-9kW	10~12	220-240V / (1PH/2PH)	41A	8# or 8.0mm <sup>2</sup>
		208V / (3PH)	25A	12# or 4.0mm <sup>2</sup>
		380-415V / (3PH)	13.7A	12# or 2.0mm <sup>2</sup>
GS08-10.5kW	12~14	220-240V / (1PH/2PH)	48A	8# or 8.0mm <sup>2</sup>
		208V / (3PH)	29A	8# or 6.0mm <sup>2</sup>
		380-415V / (3PH)	16A	12# or 4.0mm <sup>2</sup>
GS08-12kW	14~16	220-240V / (1PH/2PH)	55A	6# or 10.0mm <sup>2</sup>
		208V / (3PH)	33.3A	8# or 6.0mm <sup>2</sup>
		380-415V / (3PH)	18.2A	12# or 4.0mm <sup>2</sup>

The data provided above are for 220-240V (1PH/2PH) and 208V (3PH) and 380-415V (3PH).

## Assembly graph for power wire

**Attention:** To avoid the damage to the equipment, do not connect strong electric current to the component directly.

### **WARNING!**

This graph is for explanation only. For actual installation, refer to national and local electric codes and consult with a professional electrician.

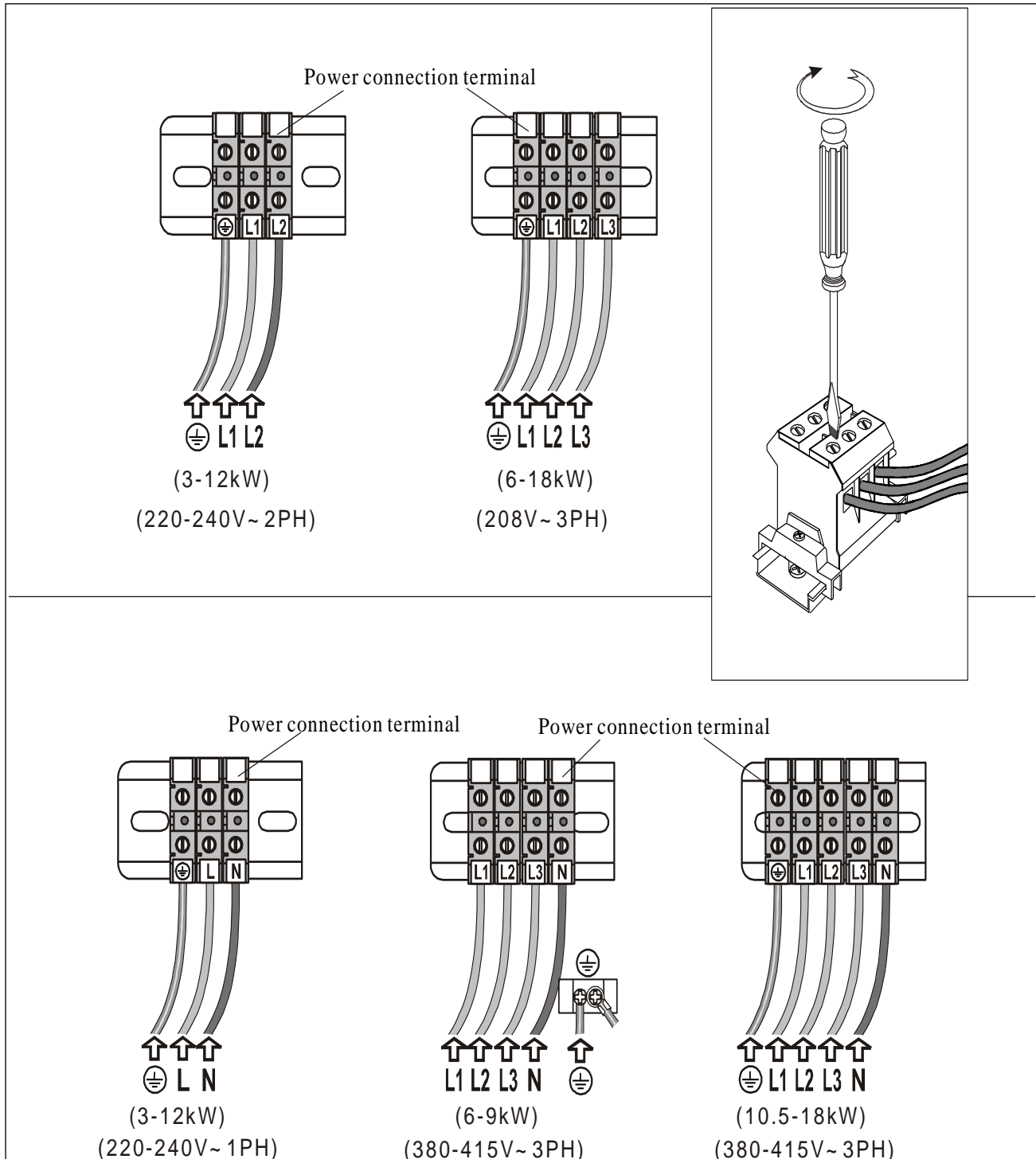

# Wiring Diagram 380-415V (3PH)

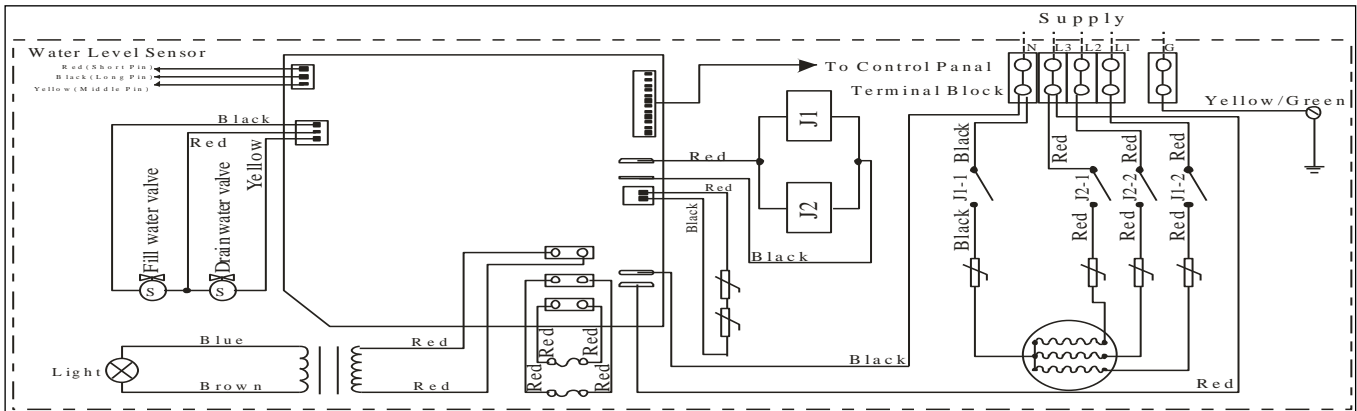

GS08-6kW/7.5kW/9kW (380-415V ~ 3PH)

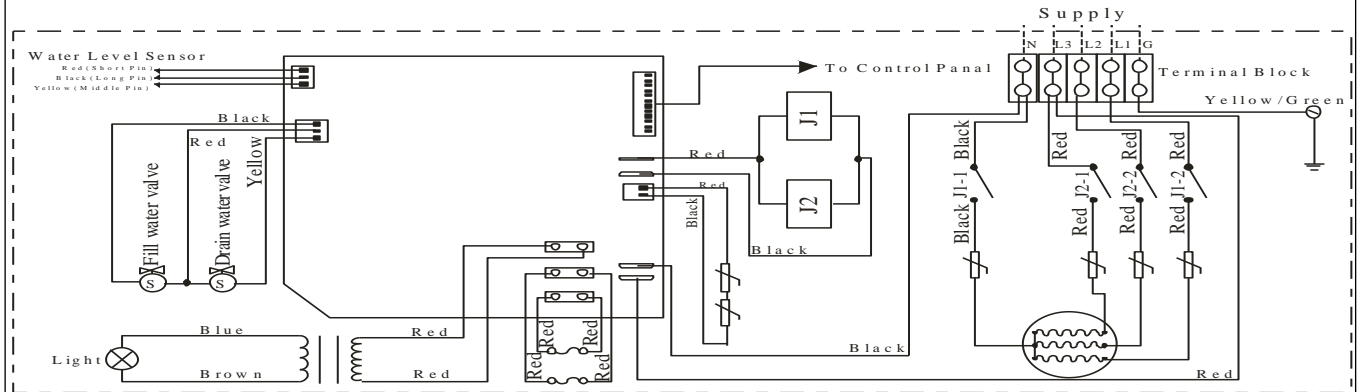

GS08-10.5kW/12kW/13.5kW (380-415V ~ 3PH)

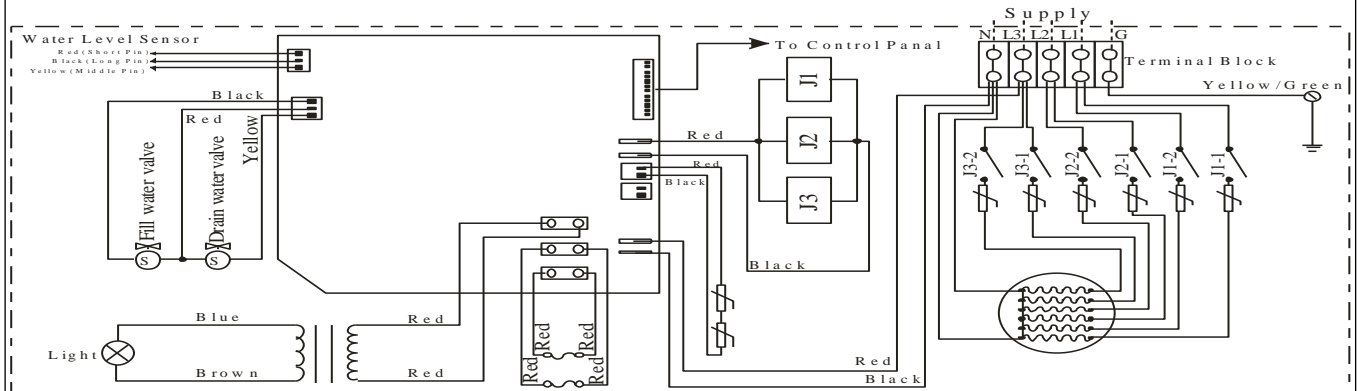

GS08-15kW/18kW (380-415V ~ 3PH)

# Wiring Diagram 208V (3PH)

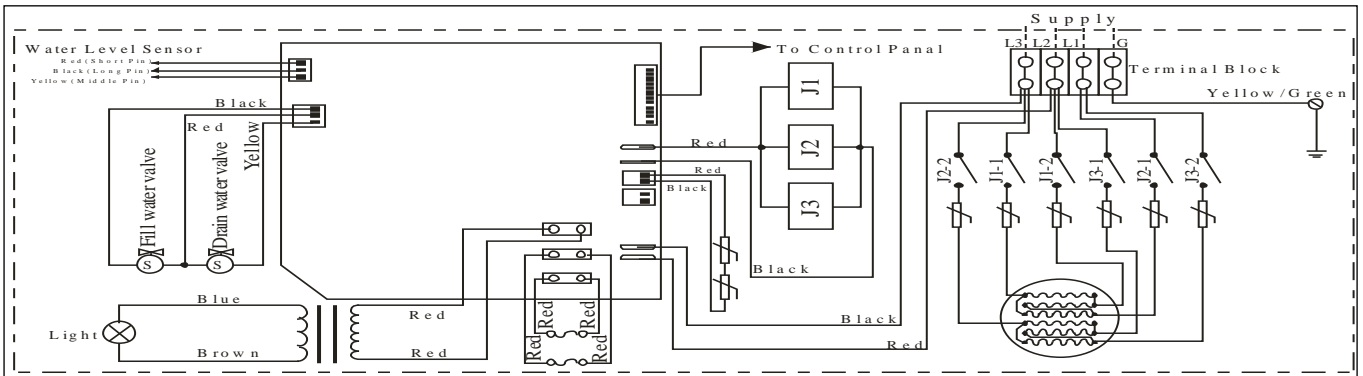

GS08-15kW /18kW (208V ~ 3PH)

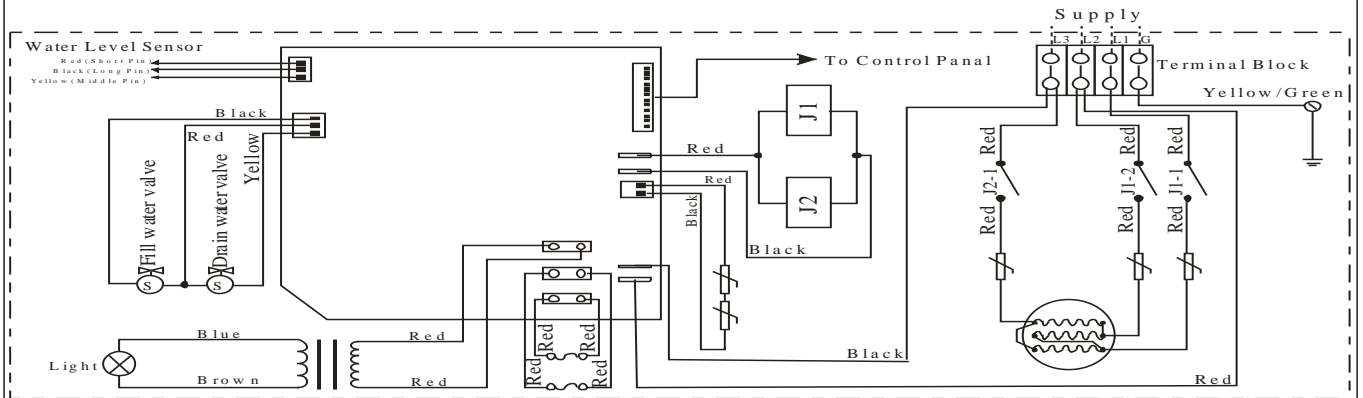

GS08-6kW /9kW (208V ~ 3PH)

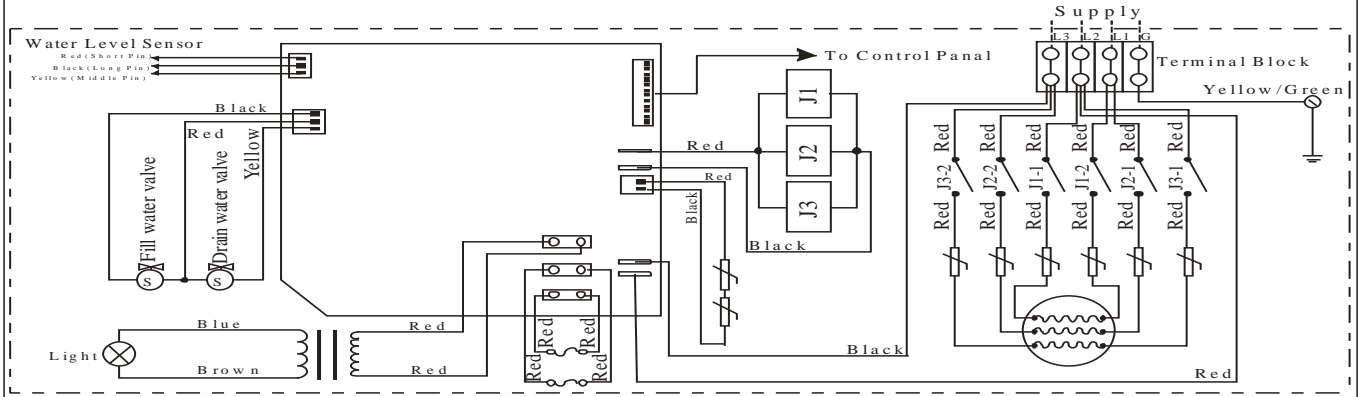

GS08-10.5kW /12kW /13.5kW (208V ~ 3PH)

# Wiring Diagram 220-240V (1PH/2PH)

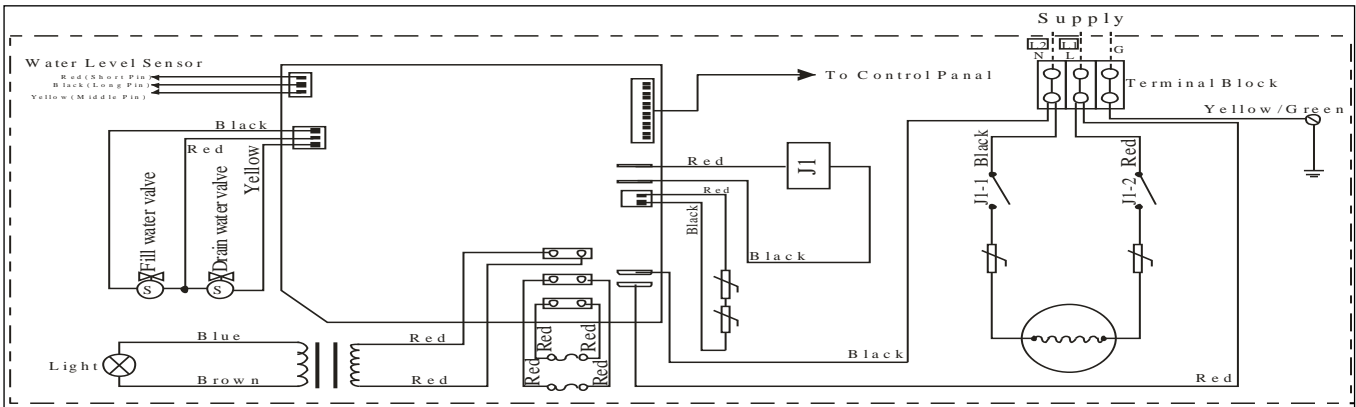

GS08-3kW (220-240V ~ 1PH/2PH)

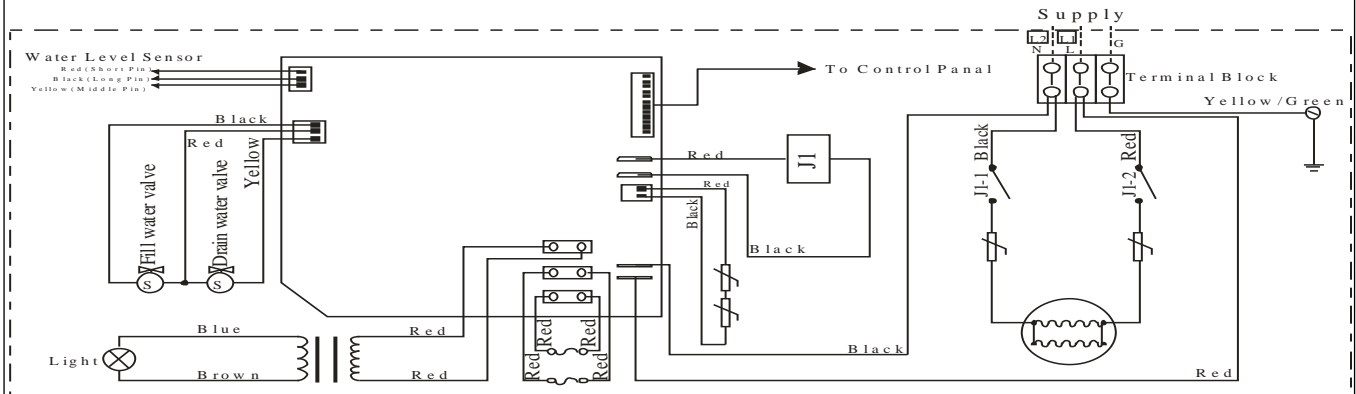

GS08-4.5kW (220-240V ~ 1PH/2PH)

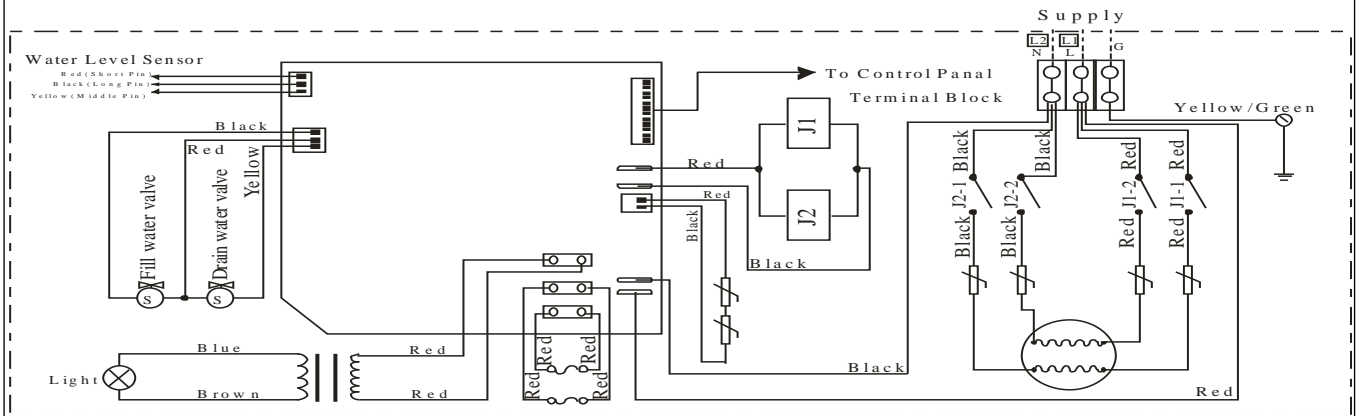

GS08-6kW/7.5kW/9kW (220-240V ~ 1PH/2PH)

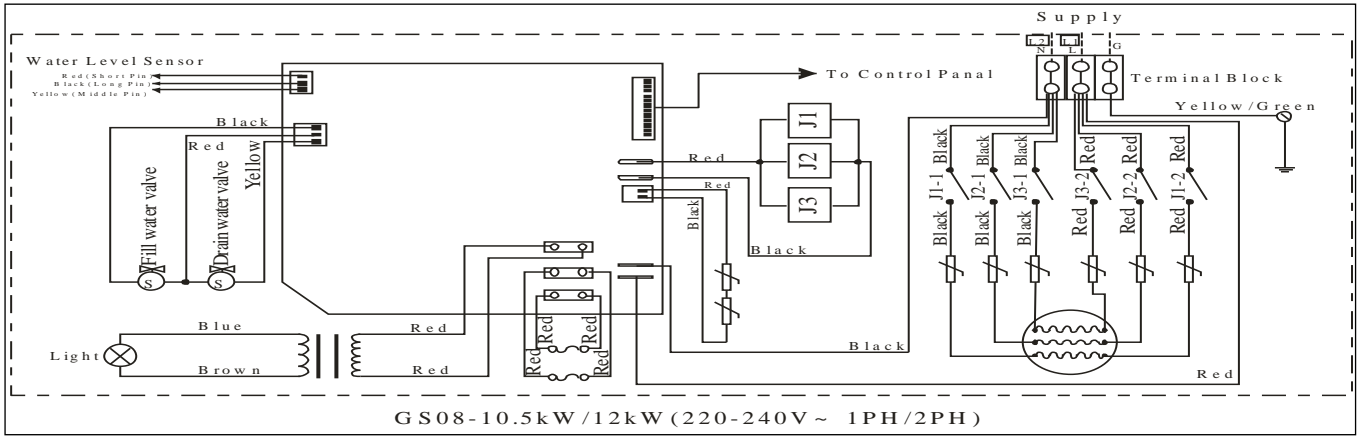

## **Installation of the top light**

**Attention:** 12V output port is available for 12V light (not included).

If the light output is 12V, the power of the light should not be more than 35W.  
The light should be installed on the top of the steam room.

**Attention:** Do not let the electrical components be exposed to moisture; otherwise, it may cause damage or short circuit.

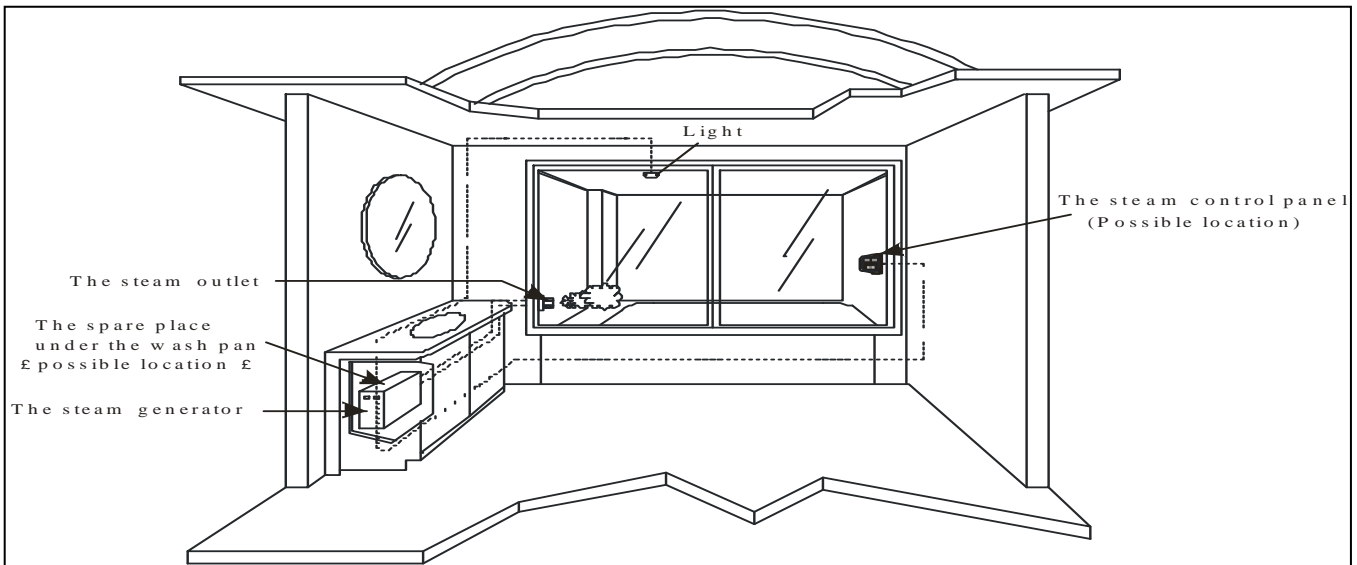

**Caution:** The illustration is just for explanation, the practical installation must comply with the national electric code, and installed by professional electrician.



## **Choose your type of machine**

Measure the length, width and height (foot) of the current steam shower or bathtub room.

Example;

L:7 x W:5 x H:8 = 280 Cubic Feet

You would need Model s-900(it is that simple)

However, if your shower materials are;

A: Natural Stone (Granite or Marble etc.)	ADD	100%
B: Exterior walls	ADD	25%
C: Ceiling Heights exceeding 8 FT.	ADD	25%
D: Ceramic tile	ADD	50%
E: Glass (2 walls)	ADD	50%

***Important:*** The calculation formula for selecting the type of steam engine is for reference only. Due to the variability of the building, the specifications and size illustration are used as guidelines only. If you have complete information, including actual blueprint, project instruction and building details, you can select the type of steam unit required. Otherwise, the manufacturer will not be responsible for the selection of the type of steam unit.

Maintenance of the steam engine

Important: Perform water discharge operation after each use.

1. Wait for the completion of automatic water discharge after each time of using the steam engine to make sure the water in the tank is discharged completely before cutting off power supply.
2. There should not be any leakage or damage among the steam engine, steam nozzle, components and pipes. They should be checked monthly.
3. Clean the water supply pipes of the steam engine once a year.
4. Check all the connections, faucets and connection terminal to see whether they become loose or are damaged due to overheating.
5. Check the furring/scaling accumulated in the water tank and electric heating tube. If the furring is thick, clean it (use diluted lemon acid to soak for 15-30 minutes).
6. Remove the water level sensory needle four times per year to clean the furring/scaling in the needle.

## Steam Generator Configuration

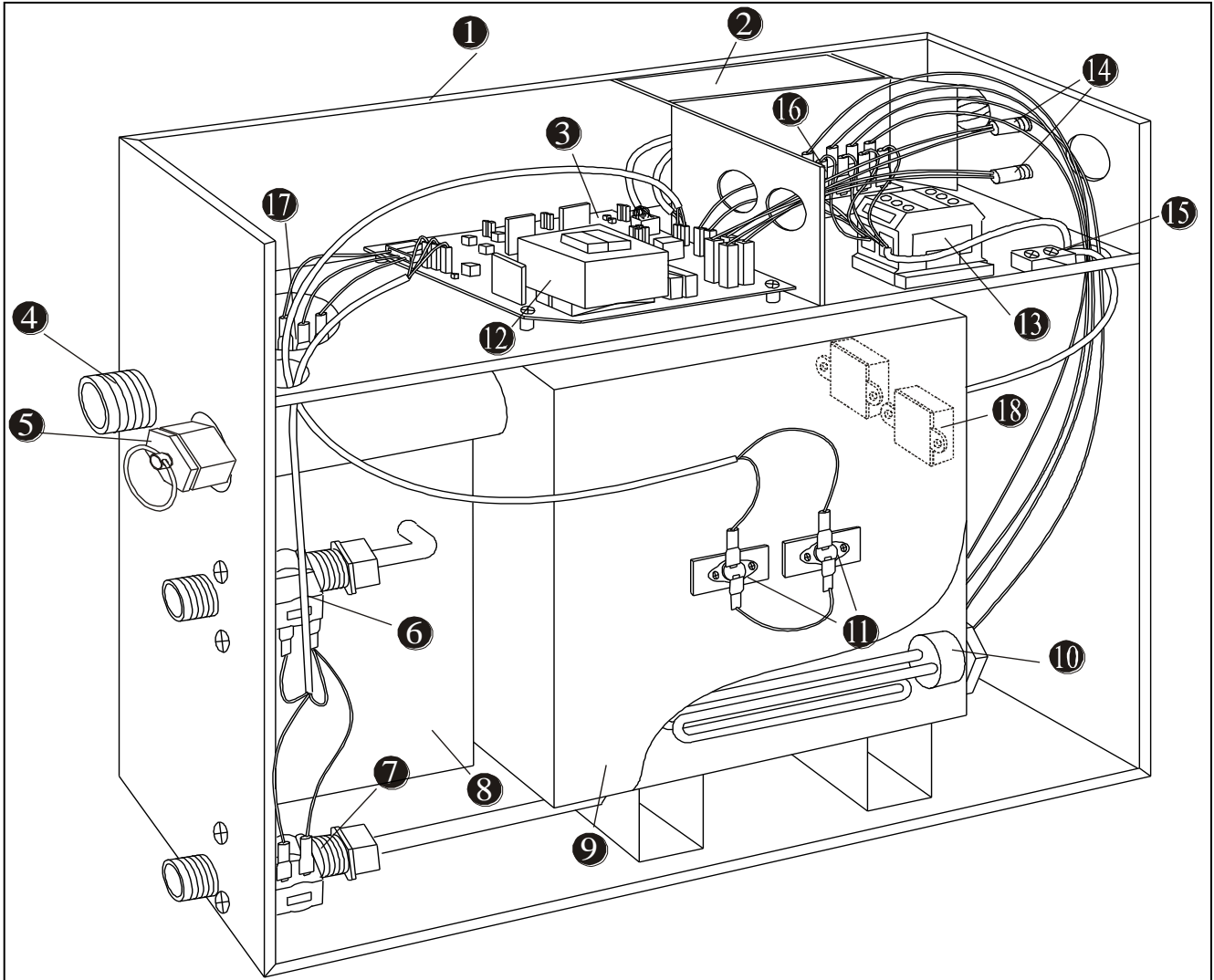

- |                         |                         |                      |
|-------------------------|-------------------------|----------------------|
| ① Enclosure             | ⑦ Water drain valve     | ⑬ Terminal block     |
| ② Insulation bracket    | ⑧ Subsidiary water tank | ⑭ Fuse               |
| ③ Circuit board         | ⑨ Main water tank       | ⑮ Ground connector   |
| ④ Steam Outlet          | ⑩ Heating Element       | ⑯ Relay              |
| ⑤ Pressure relief valve | ⑪ 221°F Hi-limit        | ⑰ Water level sensor |
| ⑥ Water fill valve      | ⑫ Transformer           | ⑱ 221°F Hi-limit     |

## Trouble shooting:

Trouble	Causes of Trouble	Trouble-Shooting Method
The machine does not start when power is supplied	<ol style="list-style-type: none"> <li>1. The fuse is burned.</li> <li>2. The wire connection terminal is loose.</li> <li>3. Bad Contact in the connection wire between the controller and the steam engine.</li> </ol>	<ol style="list-style-type: none"> <li>1. Change the fuse (on the shell 0.8A/250V)</li> <li>2. Plug-in the wire connection terminal</li> <li>3. Make sure the steam engine and the controller is in good contact.</li> </ol>
GFCI switch breaks automatically	<ol style="list-style-type: none"> <li>1. The wire connector is damp or damaged.</li> <li>2. The heating tube breaks</li> </ol>	<ol style="list-style-type: none"> <li>1. Check whether the wire connector is damp or damaged, and dry with dryer if dampened.</li> <li>2. Change the heating tube.</li> </ol>
When the machine is started, hot water comes out with little or no steam	<ol style="list-style-type: none"> <li>1. The water drainage valve is broken.</li> </ol>	<ol style="list-style-type: none"> <li>1. Change the water drainage valve.</li> </ol>
The display screen on the control panel does not display	<ol style="list-style-type: none"> <li>1. The power wire is not connected properly. The connection plug between the control panel and the electrically-controlled box is loose.</li> <li>2. Trouble with plug board.</li> </ol>	<ol style="list-style-type: none"> <li>1. Tighten the loose connector, and change the broken pipe.</li> <li>2. Change the water input valve or the water drainage valve.</li> </ol>
Water leakage	<ol style="list-style-type: none"> <li>1. The water pipe connector is loose or the pipe breaks.</li> <li>2. Water leakage in the water input valve or the water drainage valve</li> </ol>	<ol style="list-style-type: none"> <li>1. Tighten the loose connector, and change the broken pipe.</li> <li>2. Change the water input valve or the water drainage valve.</li> </ol>
No steam when starting the machine	<ol style="list-style-type: none"> <li>1. No electricity</li> <li>2. No water</li> <li>3. The set temperature is too low</li> <li>4. Trouble with wire</li> </ol>	<ol style="list-style-type: none"> <li>1. Check the power supply</li> <li>2. Check the water input pipe and water input valve</li> <li>3. Reset the temperature</li> <li>4. Contact the distributor</li> </ol>
The steam does not come out, there are water sounds in the machine	<ol style="list-style-type: none"> <li>1. The steam pipe is jammed.</li> </ol>	<ol style="list-style-type: none"> <li>1. Cut power supply to check whether the steam pipe is smooth.</li> </ol>
The light can not be turned on	<ol style="list-style-type: none"> <li>1. The fuse is burned.</li> <li>2. The light is broken.</li> <li>3. The wire is broken.</li> <li>4. The plug does not have good contact</li> </ol>	<ol style="list-style-type: none"> <li>1. Change the fuse (on the shell 1A/250V)</li> <li>2. Change the light bulb.</li> <li>3. Change wire.</li> <li>4. Replace plug</li> </ol>
The display box displays normally, but with no steam input	<ol style="list-style-type: none"> <li>1. Too much pressure inside the steam engine, so the system breaks for heat protection.</li> <li>2. The heat protection wire is broken.</li> </ol>	<ol style="list-style-type: none"> <li>1. Check the team transport pipe and restore automatically after heat protection becomes cool.</li> <li>2. Check the heat protection wire to make sure the connection is good.</li> </ol>

## **Specifications**

***Important:*** The list below is for reference only. In actual checking and repairing, based on the national and local codes, ask professional service personnel for advice.

<b>Power Output</b>	<b>3kW</b>	<b>4.5kW</b>	<b>6kW</b>	<b>7.5kW</b>	<b>9kW</b>	<b>10.5kW</b>	<b>12kW</b>	<b>15kW</b>	<b>18kW</b>
<b>Potency Error</b>	±10%	±10%	±10%	±10%	±10%	±10%	±10%	±10%	±10%
<b>Duration</b>	>1500V	>1500V	>1500V	>1500V	>1500V	>1500V	>1500V	>1500V	>1500V
<b>Resistance</b>	>20W	>20W	>20W	>20W	>20W	>20W	>20W	>20W	>20W
<b>Steam Pressure</b>	0.12MPa	0.12MPa	0.14MPa	0.14MPa	0.14MPa	0.16MPa	0.16MPa	0.16MPa	0.16MPa
<b>Steam Volume</b>	140	160	180	220	260	300	360	450	500
<b>Steam Production Time</b>	100-150	90-120	100-160	90-140	80-130	180-240	150-160	120-150	90-150
<b>Water Tank Volume</b>	2.5L	2.5L	5.7L	5.7L	5.7L	12L	12L	12L	12L
<b>Applicable space of the room (m<sup>3</sup>)</b>	3~6	4~7	5~8	7~9	10~12	12~14	14~16	18~20	20~24

***Important:*** The parameter listed in the above table may vary from place and temperature, please consult a qualified designer or architect for more detailed use.

***NOTE:*** Steam Bath Generators are considered to be able to cooperate above atmospheric pressure in abnormal operation and shall therefore comply with UL clause 64.8.

## Part 2: Control Panel



**Attention:** Before installing the controller, make sure the steam generator is shut off otherwise damage may occur.

Do not use a controller inconsistent with the steam generator, do not use the controller to operate steam generator of other brand.

The instructions include important safety, operation and maintenance information.

Keep the instruction manual handy.

If the steam generator is damaged or does not operate normally, do not continue to install or use.

### Control Panel Blueprint

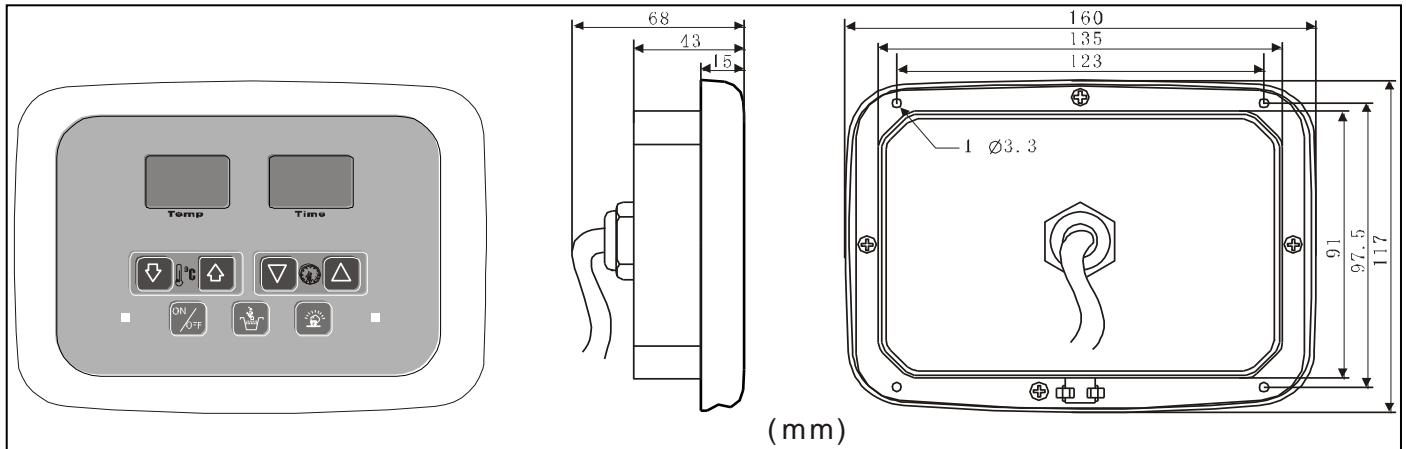

## Controller Installation instruction



**Attention:** Before installing the controller, make sure the steam engine is shut off.

### Step one

Determine the installation location of the controller.

For installation:

1. 4 -5feet away from the ground.
2. Locate controller on separate wall from steam nozzle.
3. Do not expose yourself to the direct spray of steam.

The controller wire is 1.5 feet long with a controller lengthened wire of 19.5 feet long. In the installation of controller should be in a position not more than 21 feet from the steam engine. If longer wire is needed contact professional service personnel.

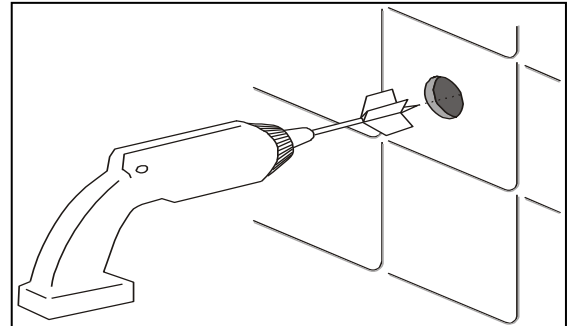

**Attention:** Do not install the controller under the water pipe or in a position where water can easily make contact.

### Step two

Drill a round hole of 35mm in diameter in a chosen position.

### Step three

Pull the controller wire through the round hole, connect it to the corresponding wire in the engine.



**Attention:** Do not over tighten or clip the controller wire.

### Step four

Start the power supply of steam engine, check and adjust connection, check each item on the 6<sup>th</sup> page to make sure all functions work properly.



**Attention:** Before setting the controller, make sure the steam engine is shut off.

### Step five

Remove the paper at the bottom.

To achieve good adhesion, make sure surface is clean and dry.

### Step six

Locate the display screen at the 12 o'clock position, and press tight. Adhere controller to the wall.



**Attention:** Level controller.

**IMPORTANT:** PLEASE place sticker that comes with unit in a visible location to pass inspection.

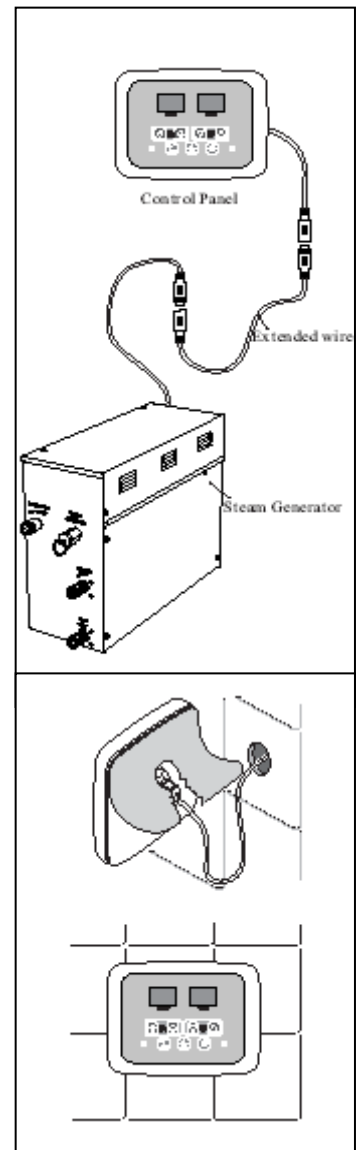

## Temperature detector installation

1. The position of the temperature sensor should be within 4-5ft above the ground. Try to avoid installing near the steam mouth or the opening side of the steam room door.
2. As shown in Fig.1, drill a small hole (10mm) in the selected position.
3. Apply silicone along the edge of the back of the detector foundation (as shown in Fig.2).
4. Use a locknut to lock the detector foundation. (As shown in Fig.2)
5. Push the temperature detector go through the back of the detector foundation (As shown in Fig.3)
6. The temperature detector should be installed by extending about 1cm from the front of the room for accurate temperature.
7. Apply silicone to the back and set the detector. (As shown in Fig.3)

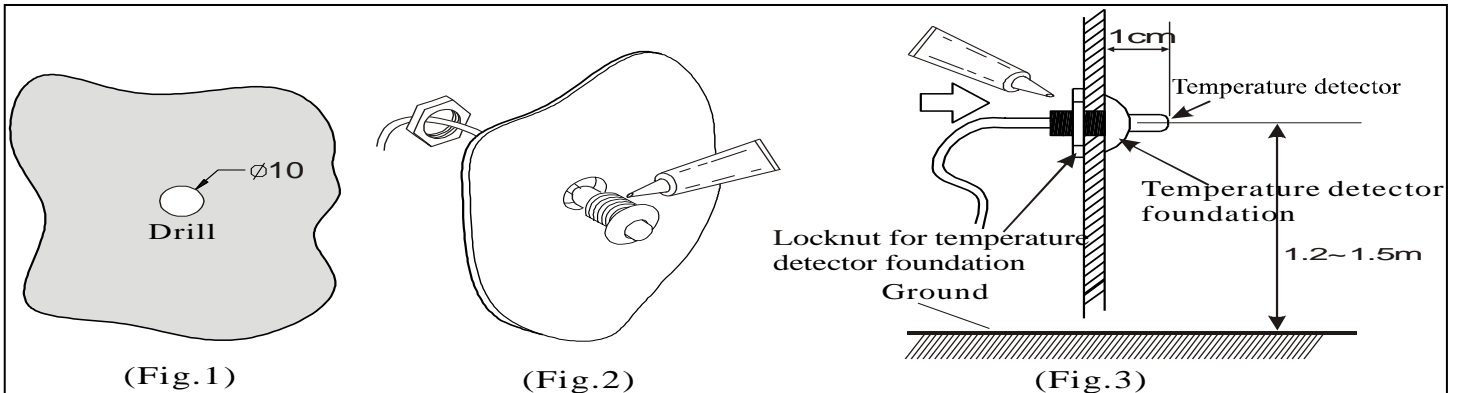

## Controller Panel illustration

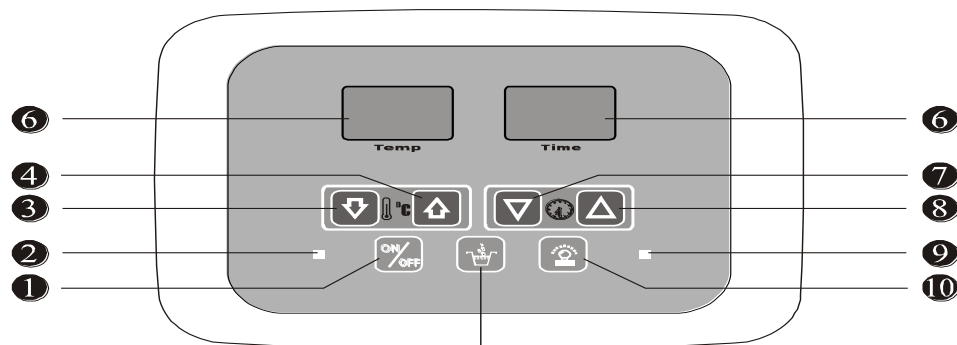

- |                                      |                   |                               |
|--------------------------------------|-------------------|-------------------------------|
| ① Power ON/OFF                       | ⑤ Water drain Key | ⑥ LED SCREEN                  |
| ② Steam Indicator LED                |                   | ⑦ Steam Time Adjust Key--LOW  |
| ③ Steam Temperature Adjust Key--LOW  |                   | ⑧ Steam Time Adjust Key--HIGH |
| ④ Steam Temperature Adjust Key--HIGH |                   | ⑨ Power Indicator LED         |
|                                      |                   | ⑩ Mood Light ON/OFF           |



## **Operation Instruction:**

1. When power supply is applied to the steam box system the RED stand-by light will be illuminated. (see **Illustration of the controller panel** for location)
2. Pressing the ON/OFF button will start the system. The steam box will fill with water. This will take a few minutes; the water may cycle on and off a few times as the water tank fills. This is normal operation. The display will show ambient Temperature and Running time – 8hrs.
3. When the red light next to the ON/OFF button becomes illuminated the system is operating and will start generating steam for 5 – 8 minutes.
4. Pressing the UP and Down arrows under the temperature display will adjust the temperature accordingly. The temperature can be changed from Celsius to Fahrenheit . The temperature range is 25°C to 68°C or 78°F to 150°F. The unit will cycle on and off to maintain the set temperature.  
  
Once the user has adjusted the temperature to their preferred temperature, the temperature lights will blink several times and time will be the active temperature.
5. When system is on, press UP or DOWN triangle keys on control panel to adjust running time, meanwhile, time display window shows the time you desire. The steam time range is 1minute to 8hours. When setting time to less than 1hour, the time unit is by the minute; when more than 1hour, the unit is hour and time display window will indicate h.
6. When system is on, press the LIGHT key to turn on light; press again to turn off.
7. When system is in waiting state, press keys DOWN temperature key and UP triangle at the same time will switch Fahrenheit and centigrade and temp display window display/ F means Fahrenheit; display C means centigrade. System will save it for next usage.



### **Attention:**

1. *Use soft cloth with soap and water to clean the controller.*
2. *Do not use abrasive cleaning tools.*