

Operating Instructions

Race Car Tympanometer



Operating Instructions

Race Car Tympanometer

Table of Contents		Page
1	Introduction	1
2	Description	2
2.1	Tympanometry	2
2.2	Acoustic Reflex	3
3	Getting started	4
3.1	Unpacking	4
3.2	Environmental conditions for the RC	5
3.3	Preparing the RC for use	5
3.4	Getting familiar with the RC	6
3.5	Calibrate the probe	9
3.6	Getting familiar with the probe	10
3.7	Choose an appropriate ear tip	11
4	How to create a tympanogram	12
4.1	The basics of the impedance measurement	12
4.2	Preparing the patient	14
4.3	Preparing the measurement	14
4.4	Measuring the tympanogram	14
4.5	How to evaluate the tympanogram display	15
4.6	Performing the tympanometry test w/ animation	16
4.7	Graphics and screens	16
4.8	How to print the test result	18
4.9	How to delete the test results	18
5	How to create a tympanogram with high probe tone	19
5.1	To select high probe tone frequency	19
6	How to measure the Stapedius reflex	20
6.1	The basics of the Stapedius reflex measurement	20
6.2	Preparing the patient	20
6.3	Preparing the ipsilateral measurement	21
6.4	Taking the ipsilateral measurement	22
6.5	Preparing the contralateral measurement (optional)	23
6.6	How to interpret the reflex display	23
6.7	How to print the test results	24
7	Interpreting Test Results	25
7.1	Understanding the printout	25
7.2	Interpreting the tympanometric test result	26
7.3	Abnormal Values	26
8	How to test children	28
9	Additional Reading	29
10	Individual Setup of the RC	30

Operating Instructions

Race Car Tympanometer

10.1	The setup menu	30
10.2	The tympanometer setup	31
10.3	The Setup menu for Reflex Test	32
10.4	The Common Setup Menu	33
10.5	Insert your personal printout data.....	34
11	Care and maintenance of the instrument.....	35
12	How to change the printer paper	36
13	Warranty, maintenance and after-sales service.....	37
13.1	Warranty	37
13.2	Maintenance	38
14	Safety regulations	40
14.1	Electrical safety:.....	40
14.2	Measuring accuracy:.....	40
14.3	Device control:	40
15	Checklist for subjective device control	41
16	Technical Data and Accessories.....	42

Operating Instructions

Race Car Tympanometer

1 Introduction

Thank you very much for purchasing a quality product from MAICO. This automatic **Race Car (RC) Tympanometer** is manufactured to meet all quality and safety requirements.

This user manual should make it as easy as possible for you to become familiar with the functions of the **RC**. The description of the position (e.g., ⑤) of controls, displays and connections, found again in the text, will make it easier for you to learn how to operate the **RC**.

If you have problems or have ideas for further improvements, please get in touch with us. Simply call.

Your **MAICO** team

Operating Instructions

Race Car Tympanometer

2 Description

The **RC** is an automatic instrument that is designed for tympanometric screening. Tests done in the tympanometric screening mode measure middle ear mobility and ipsilateral acoustic reflex. Contralateral acoustic reflex is available as an option. Test results are displayed on the front panel LCD (liquid crystal display) screen and may be printed.

The design of the **RC** allows rapid and reliable measurements. This equipment is designed for middle ear function screening.

PC-Interface:

A USB interface for data transfer to a connected computer is built in.

2.1 Tympanometry

Tympanometry is the objective measurement of middle ear mobility (compliance) and pressure within the middle ear system. During the test, a tone (226 Hz, or 1000Hz) is presented to the ear canal by means of the hand-held probe. This tone is used to measure the change in compliance in the middle ear system while the air pressure is varied automatically from a positive value (+200 daPa) to a negative value (-400 daPa max.).

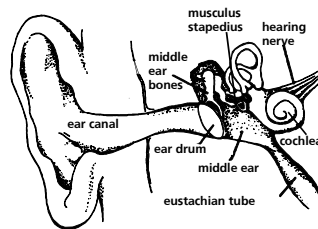

Figure 1
The middle ear

Maximum compliance of the middle ear system occurs when the pressure in the middle ear cavity is equal to the pressure in the external auditory canal. This is the highest peak of the curve as it is recorded on the chart. The position of the peak on the horizontal axis and on the vertical axis of the chart will provide diagnostic information regarding the function of the middle ear system. Examples of normal and abnormal tympanograms can be found in a later section of this manual.

Gradient calculations are reported as the tympanogram width at half of peak compliance expressed in daPa. A "limits" box is available on both the display and printout to aid in diagnosis.

Compliance is measured with respect to an equivalent volume of air, with the scientific quantity milliliter (ml). Air pressure is measured in deca-Pascals (daPa).

NOTE: 1.02 mm H₂O = 1.0 daPa.

Operating Instructions

Race Car Tympanometer

2.2 Acoustic Reflex

An acoustic reflex, or contraction of the Stapedius muscle, occurs under normal conditions when a sufficiently intense sound is presented to the auditory pathway. This contraction of the muscle causes a stiffening of the ossicular chain which changes the compliance of the middle ear system. As in tympanometry, a probe tone is used to measure this change in compliance.

When the stimulus presentation and measurement are made in the same ear by means of the probe, this acoustical reflex is referred to as an ipsilateral acoustic reflex. When the stimulus presentation and measurement are made in opposite ears, the reflex is referred to as a contralateral acoustic reflex.

For best results, this reflex measurement is automatically conducted at the air pressure value where the compliance peak occurred during the tympanometric test. Stimulus tones of varying intensities at 500, 1000, 2000 or 4000 Hz are presented as short bursts. If a change in compliance greater than 0.05 ml is detected, a reflex is considered present. Because this is an extremely small compliance change, any movement of the probe during the test may produce an artifact (false response). The test result is recorded as **Pass/No Response**, and in graphical form.

If the tympanometric results display any abnormal findings, the results of the acoustic reflex testing may be inconclusive and should be interpreted with care. Theoretically, a compliance peak is necessary to observe a reflex at peak pressure.

Operating Instructions

Race Car Tympanometer

3 Getting started

Your **RC** was carefully inspected and packed for shipping. However, it is good practice to thoroughly inspect the outside of the shipping container for signs of damage. If any damage is noted, please notify the carrier immediately.

3.1 Unpacking

Remove the accessories. Carefully remove the instrument from the shipping carton. Remove the instrument from the plastic bag and inspect the case for any damage. Notify the carrier immediately if any mechanical damage is noted. This will assure that a proper claim is made. Save all packing material so the claim adjuster can inspect it as well. When the adjuster has completed the inspection, notify the **MAICO** Special Instrument Distributor you purchased this unit from.

Save all the original packing material and the shipping container so the instrument can be properly packaged if it needs to be returned for service or calibration.

3.1.1 Accessories Supplied

Please check that all accessories listed below are received in good condition. If any accessories are missing or damaged, immediately notify your **MAICO** Special Instrument Distributor.

Description	Part No.
Hand-held probe	570G-14
24-count eartips kit:	6613
(4) yellow, 7 mm	6643
(4) green, 9 mm	6644
(4) white, 11 mm	6645
(4) yellow, 13 mm	6646
(4) green, 15 mm	6647
(4) blue, 18 mm	6648
Thermal printer paper	5529
Calibration test cavity	5533
Operating Instructions	1162-0321
Optional Accessories:	
Soft-sided carrying case	1035-3002
Contra button phone and cable	4796
Contra TDH 39 phone and cable	4682

Operating Instructions

Race Car Tympanometer

3.2 Environmental conditions for the RC

The **RC** should be operated in a quiet room.

The test room must be at normal temperature, usually 15° C / 59° F to 35° C / 95° F, and the instrument should be switched on about 10 minutes before the first measurement to guarantee precise measuring results. If the device has been cooled down (e.g. during transport), please wait until it has warmed up to room temperature

3.3 Preparing the RC for use

3.3.1 Connect probe and accessories

- Connect the probe cable to socket (C) on the rear of the instrument.
- Insert the plug into the socket and secure the connection by fastening the two screws of the connector.
- Insert the pressure tube into the socket (B) and press it until it is secure on the socket.
- Put the enclosed power cable into the power connection socket (A) and then plug it into a power outlet. The instrument is now operational.



Figure 2
The probe of the RC

Operating Instructions

Race Car Tympanometer

3.4 Getting familiar with the RC

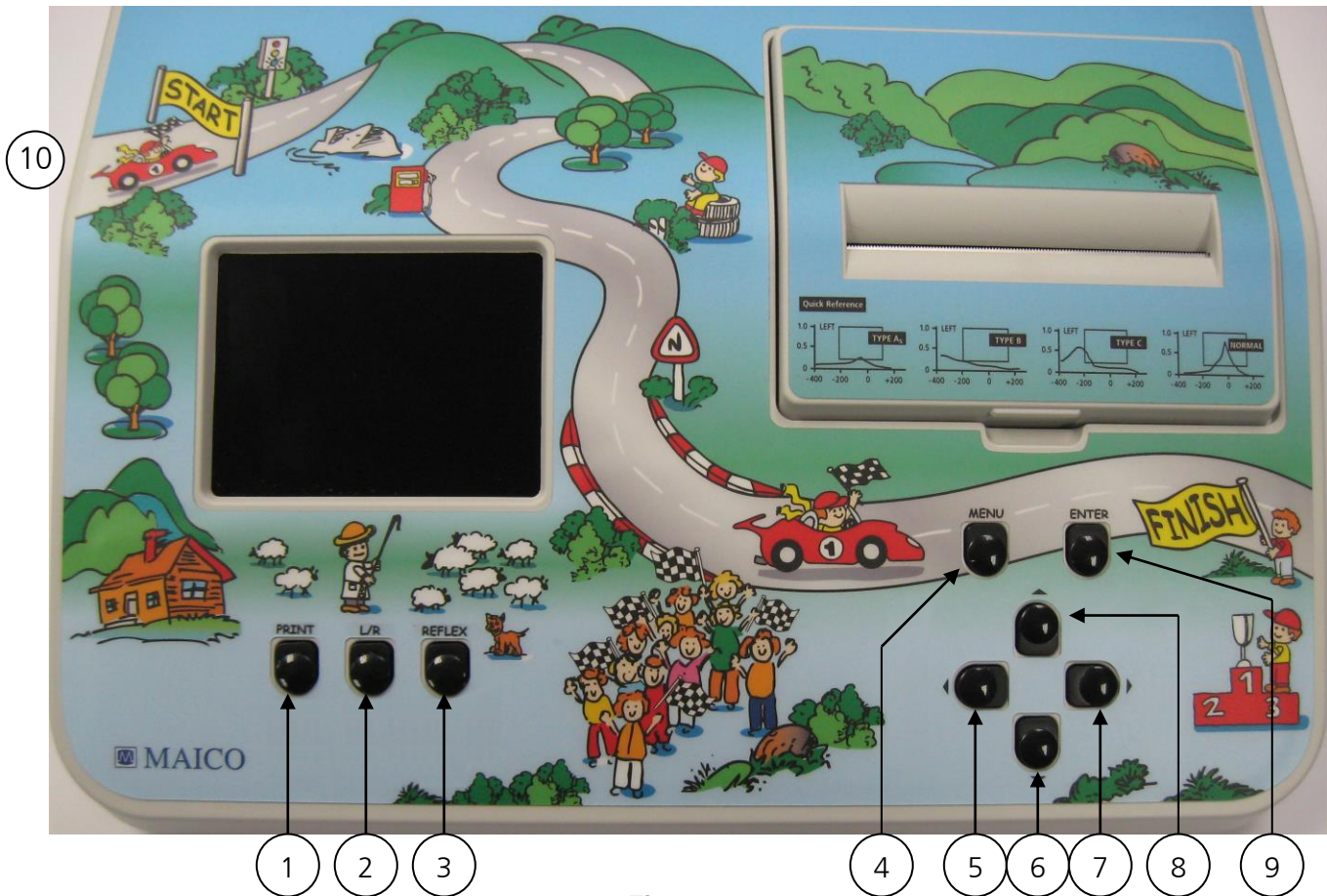

Figure 3
The controls of the RC

3.4.1 The RC Front Panel Controls

1. **PRINT** = Prints the test results.
2. **L/R** = Changes test ears from left to right, or right to left for tympanogram or audiogram. Press and hold for 2 seconds to erase stored tests.
3. **REFLEX** = Changes the reflex testing modes from IPSI to CONTRA or NO REFLEX. (Press and hold to change to 1000Hz probe tone for tympanometry.)
4. **MENU** = Enters the main menu screen
5. ◀ = Decreases the frequency (Hz) for audiometric testing.
6. ▼ = Decreases the intensity level (dB) of reflex or audiometric testing.
7. ▶ = Increases the frequency (Hz) for audiometric testing.
8. ▲ = Increases the intensity level (dB) of reflex or audiometric testing.
9. **ENTER** = Enters the highlighted menu or the highlighted option.
10. **POWER** = Power switch

How to use the extended functions is described in chapter 9: "Individual Setup of the RC."

Operating Instructions

Race Car Tympanometer

The RC Rear Panel Connections

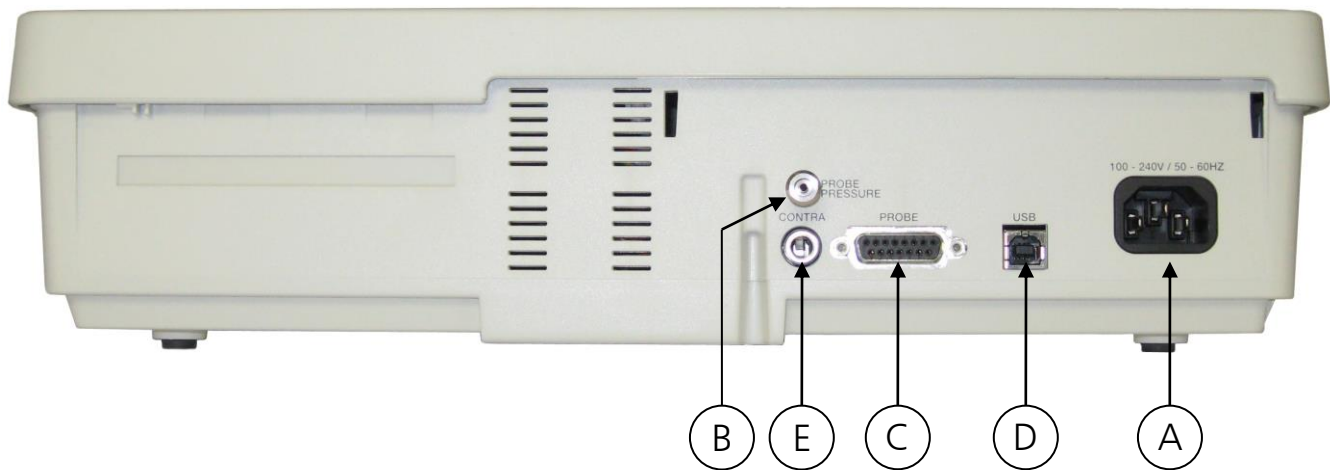

Figure 4
Connectors on the rear of the RC

- A. Power connection socket
- B. Probe tube connection
- C. Probe connection socket
- D. PC interface
- E. Contra receiver socket

3.4.2 Switch the instrument on

Turn the power switch (10) on. The LCD will show the type of instrument and software version for a moment. Then the basic measuring figure appears.

The **RC** should be switched on about 10 minutes before the first measurement to guarantee precise measuring results. If the device has been cooled down (e.g. during transport), please wait until it has warmed up to room temperature.

Operating Instructions

Race Car Tympanometer

3.4.3 The display of the RC

The test result is shown during the measurement on the LCD. The measurements are saved automatically and can be printed out in a fast and quiet way with the integrated printer.

In figure 5 the initial empty measurement screen is shown. The measurement screen shows actual settings, test results and the graphical display of the tympanogram and reflexes.

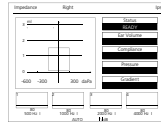

From left to right the top line shows the type of test (impedance is shown in Figure 5) the selected test ear (left or right) and the selected reflex test (*ipsi*, *contra* (optional) or *tympanogram* if no reflex test is selected).

Figure 5
The measurement screen of the RC

At the left center, the graph of the tympanogram is shown. At the right, five boxes show the status and test values.

The upper box shows the actual status of the instrument:

- READY** - means that the instrument is ready for testing
- IN EAR** - shows that the probe is inserted in the ear
- TESTING** - means that the test is in progress
- BLOCKED** - means that probe is blocked in the ear
- LEAKING** - indicates that the ear tip does not have a proper seal

The boxes below **Status** show the volume of the ear canal, the compliance, the pressure at maximum compliance and the gradient of the tympanogram when the test has been completed.

The four boxes at the bottom of the screen, marked 1 to 4, show the graphical reflex curves after the test. Below each box the test level (Figure 5: 80 dB), and the test frequencies (Figure 5: 500 Hz, 1000 Hz, 2000 Hz and 4000 Hz) are displayed. After the frequency an "I" shows that ipsilateral testing is selected.

Finally, at the very bottom in (Figure 5) the word **Auto** and 80 dB scale is shown. This means that the reflex test level will increase automatically until a reflex is found or the maximum level is reached. With the arrow keys, the test levels can be changed to a fixed level. The dB values below the boxes change accordingly. It is possible to have fixed levels from 70 dB to 100 dB or **Auto**.

Operating Instructions

Race Car Tympanometer

3.5 Calibrate the probe

Adjust the impedance measuring instrument every day to the actual atmospheric pressure by means of the enclosed calibration volume. The calibration is very easy and takes only 20 seconds.

Press the menu key **4** and the main menu (Figure 6) appears on the LCD. Select the menu option **Calibration** with the arrow keys and press **Enter**. Follow the instructions on the LCD as shown in figure 7.

Put the probe tip **S** without ear tip into the hole of the test cavity labeled 0.5 ml. The text on the display will request that the probe tip be inserted for the 2 ml calibration. Put the probe tip in the 2 ml cavity. Do this again for the 5 ml volume. The **RC** will automatically change into the tympanometry mode. The basic menu for the impedance measurement appears again and you are ready for measurements.

If the error information **Cavity Calibration Out of Range** appears during the calibration, please check if the opening of the probe tip is clean and try to recalibrate the probe. If the error information appears again, the probe or the instrument is probably in need of service. Inform your Maico Special Instrument Distributor to get immediate help.

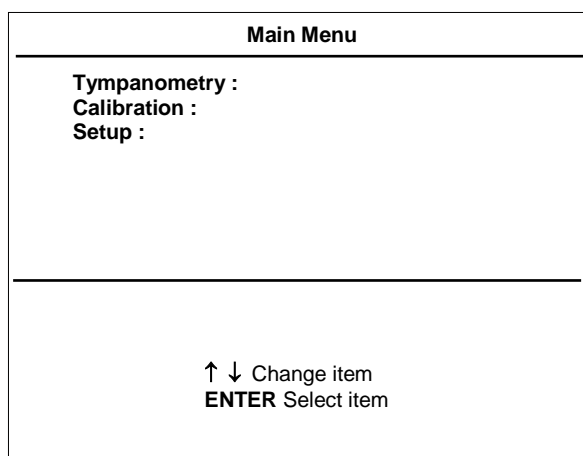

Figure 6
The RC main menu

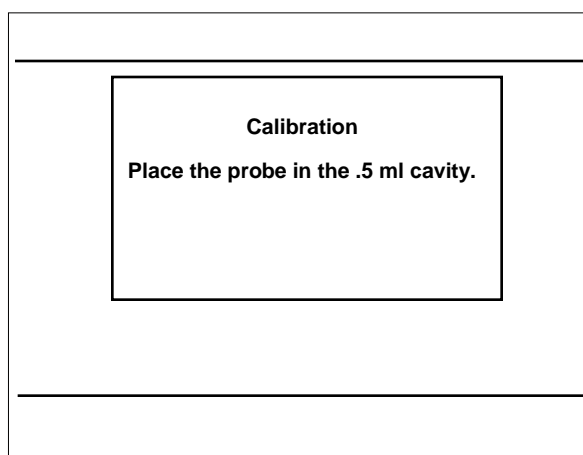

Figure 7
The calibration screen

Operating Instructions

Race Car Tympanometer

3.6 Getting familiar with the probe

The probe of the **RC** is shown in figure 8. The probe head is adjustable to three angles (0°, 60° and 80°). It is adjusted by turning the locking screw (T) at the bottom of the probe using a coin or a screw driver.

Adjust the probe head (P) by pulling it into the required position until it rests. After it is set to the required position tighten the fixation screw again.

The probe button (M) can be used to select the required test ear.

The color of the (O) control light changes accordingly to red (right ear) or blue (left ear).

The color of the control light on the probe indicates your current operation.

A red control light indicates that the right ear is selected.

The system is ready for measurements. As soon as you have put the probe into

the auditory canal the control light turns green. Now the test is in progress. Do not change the position of the probe until the green control light goes out indicating the end of the measurement.

A blue control light indicates that the left ear is selected. The system is ready for measurements. As soon as you have put the probe into the auditory canal the control light turns green. Now the test is in progress. Do not change the position of the probe until the green control light goes out indicating the end of the measurement.

A yellow control light indicates an error. The kind of error is indicated on the LCD under status:

LEAKING: The ear tip is not sealed in the auditory canal. Change the position of the probe until the control light turns green. If you are not successful use a bigger ear tip.

BLOCKED: Indicates blockage in the probe opening. Change the position of the probe so that it points straight into the auditory canal until the control light turns green. If you are not successful, check that the probe is not blocked with ear wax.

The complete probe insert can be changed by pressing the release button (Q).

If the probe tip is clogged, you can remove it by opening the fixation ring (R). After cleaning the probe tip or attaching a new one, the tip must be fixed again by

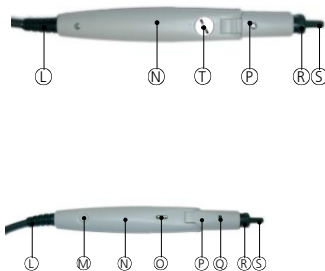

Figure 8
The probe of the RC

Operating Instructions

Race Car Tympanometer

fastening the fixation ring.

3.7 Choose an appropriate ear tip

Choose an ear tip of the appropriate size from the ear tip set. Put the ear tip tightly on the probe tip. The probe tip should end near the end of the ear tip. It should not be inserted more than about 1 mm inside the ear tip or just protrude out of the ear tip (see Figure 9).

By choosing an appropriate ear tip and placing it correctly on the probe you create the basic conditions for measurements without problems and mistakes.

Now all preparations are concluded and you can start the impedance and reflex measurement. Please read the following chapters.

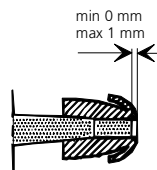

Figure 9
Proper placement
of ear tip

Operating Instructions

Race Car Tympanometer

4 How to create a tympanogram

In the following paragraph we will briefly explain the principle and the background of the impedance measurement to create a better understanding. If you want to begin the measurements immediately, just skip this paragraph and continue reading section 4.3 "Preparing the Measurements."

4.1 The basics of the impedance measurement

The impedance measurement assists in diagnosing of the condition of the middle ear and can therefore not be compared directly with other audiometric tests such as sound or speech audiometry which assists in the measurement of hearing. Furthermore the impedance measurement is an objective measuring method which does not depend on the cooperation of the test person and can therefore not be falsified by the patient.

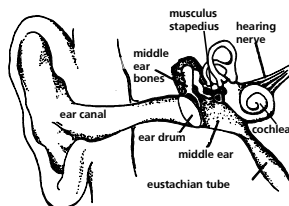

The two most important impedance measuring methods possible with your **RC** are tympanometry and the measurement of the Stapedius reflex which is discussed in chapter 5: "How to measure the Stapedius reflex."

Figure 10
The middle ear

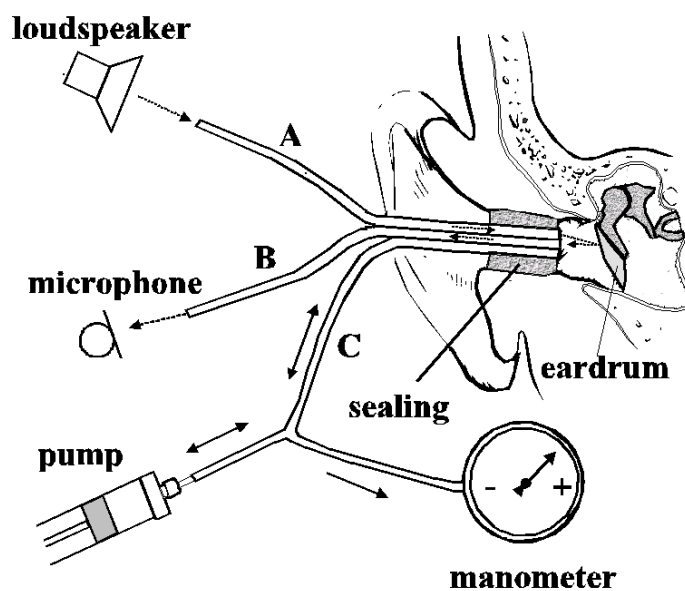

Figure 11
Principle of the impedance measurement

Operating Instructions

Race Car Tympanometer

The impedance measurement examines the acoustic resistance of the middle ear. If the eardrum is hit by a sound, part of the sound is absorbed and sent via middle ear to the inner ear while the other part of the sound is reflected. The stiffer the eardrum the more sound reflected, and therefore less sound reaches the inner ear. Inside the probe of the impedance measuring instrument a small loudspeaker is installed which emits a tone through a tube (Figure 11: A) into the auditory canal before the eardrum. Another tube (Figure 11: B) is connected to the microphone inside the probe which receives the sound. Together with a third tube (Figure 11: C), all three are inserted nearly to the eardrum and are made airtight against outside pressure by the ear tip. A manometer and a pump, which can produce both positive and negative pressure, are connected with tube C. Less sound is reflected to the microphone when the eardrum is stiff and the eardrum transmits the majority of the sound via the middle ear to the inner ear. The highest compliance is normally reached with an air pressure corresponding to the outside pressure.

During a Tympanometry measurement, a continuous change of positive and negative pressure is produced by the pump of the instrument in the outer auditory canal. The compliance is measured simultaneously and shown in a diagram (the tympanogram) which illustrates the compliance in ml over the pressure in daPa. In Figure 12), the area for normal tympanogram curves is hatched. Here you can see that the highest compliance is reached with normal pressure. When you create positive and negative pressure the eardrum stiffens - the compliance decreases.

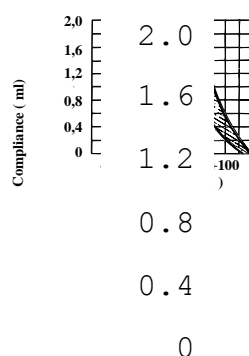

Figure 12
Tympanogram
(normal curve area is hatched)

So you can draw conclusions on the condition of the middle ear from the shape and the values of the tympanogram.

Operating Instructions

Race Car Tympanometer

4.2 Preparing the patient

Explain to the patient that the measurement is painless and that nothing enters the auditory canal. The patient does not have to respond when there are loud test sounds or when the pressure in the auditory canal changes. In no case should the patient swallow, chew or move during the measurement.

4.3 Preparing the measurement

The LCD shows the empty measurement screen for the right ear and the control light of the probe turns red. To measure the left ear, change the side by pressing the **L/R** key or the probe button (M). Then the selected test ear shown in the middle-top of the LCD will change from **Right** to **Left** and the control light of the probe will turn blue. Switch off the reflex measurement by pressing the **Reflex** key (3).

The word **Tympanometry** must appear at the right top of the display. Make sure the auditory canal is clear. Choose an ear tip according to the size of the auditory canal and put it firmly onto the probe tip (see Figure 9 in chapter 3.7).

4.4 Measuring the tympanogram

Take hold of the top of the outer ear and pull it back. Insert the probe with the ear tip into the auditory canal until the control light of the probe is green indicating the start of the test. Do not move the probe until the green light goes out; the patient must not swallow or speak during the measurement. During the test the LCD will display the tympanogram on the left side as the test is running and then the values will appear on the right side. After about 4-5 seconds the test is completed and the green light turns off. Now you can remove the probe from the ear.

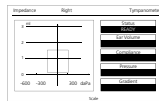

Figure 13
Measurement screen (only tympanogram)

If an error occurs during the measurement the test will stop. If leakage occurs, the control light of the probe turns yellow and **Leaking** will appear under **Status**. If the probe is blocked, the control light of the probe turns yellow and **Blocked** will appear under **Status**. Please proceed as described in chapter 3.6 "Getting familiar with the probe." To measure the other ear, change the side by pressing the **L/R** key or the probe button and repeat the measuring procedure described above with the other ear.

Operating Instructions

Race Car Tympanometer

4.5 How to evaluate the tympanogram display

After having completed a measurement you can see the results on the LCD.

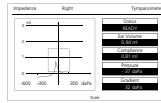

On the left side of the display you see a graph of the tympanogram. The area surrounded by the box is valid for "normal" tympanograms. You can change the area or turn it off.

For details see chapter 10 "Individual Setup of the **RC.**"

In the top-middle of the LCD, the words **Right** or **Left** indicate the ear chosen at the moment.

Figure 14
Display of a normal tympanogram

Tympanometer (at the top right) - indicates that the reflex measurement has been switched off.

In the boxes to the right the following test measurements are displayed:

Ear Volume - indicates the volume of the section of the auditory canal between the ear tip and the eardrum in ml (in the example 0.94 ml).

Compliance - indicates the maximum value of the compliance from the tympanogram in ml (in the example 0.81 ml).

Pressure - indicates the pressure with the highest measured compliance (in the example -37 daPa).

Gradient - calculations are reported as the tympanogram width at half of peak compliance expressed in daPa (in the example 32 daPa).

Operating Instructions

Race Car Tympanometer

4.6 Performing the tympanometry test w/ animation

NOTE: Animation must be turned on in set-up menu (see section 10.4 the common set-up menu)

- Press **ENTER** to activate the **RC** animation.
- INSERTING THE PROBE:

While the child is distracted by the graphics, Place the hand held probe (with proper ear tip) inside the child's ear while gently pulling the earlobe down. Check for excess wax or obstructions. Because children have very small ear canals, this allows the operator to maintain a seal easily.

NOTE: The ear tip does not need to go into the ear canal. It should only seal the canal opening. Attempt to point the end of the ear tip into the canal, toward the eardrum. Depending on the child, or larger size ear tip may be needed to secure a proper seal.

4.7 Graphics and screens

The Race Car Tympanometer or Race Car Tympanometer W/Audiometer will show different graphics throughout the test. In addition, the status of the test will also be indicated at the top of the screen.

When the Instrument is ready to test, the following screen will appear. "Ready" status will be indicated at the top of this screen.

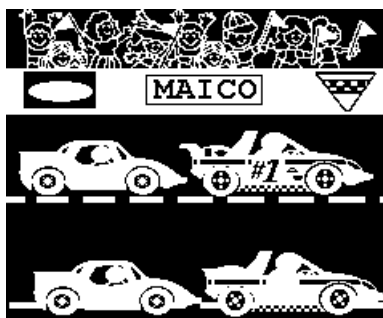

When the probe is inserted into the ear the status changes to "in ear". When a proper seal is detected, the test status will change to "testing". The graphic of the Race Car will also change as displayed below.

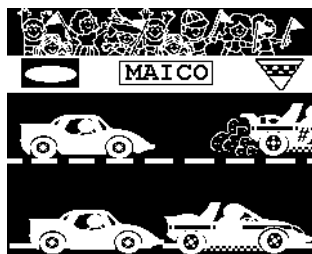

Operating Instructions

Race Car Tympanometer

When the test is finished, the following screen will appear.



The actual tympanogram with numerical data will then appear on the screen for review.

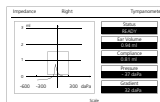

To test the other ear with **RC** animation, first switch the ears with the L/R button, then press **ENTER** to start the animation. Perform the test in the same way as stated above.

If a leak is detected during the test, the following graphic will be displayed. "Leaking" will be displayed at the top of the screen.



If the probe tip is blocked (either by wax or up against the ear canal wall), the same graphic will display. But "Blocked" will be displayed at the top of the screen. In either case, remove the probe and re-insert into the ear to re-start the test.

Operating Instructions

Race Car Tympanometer

4.8 How to print the test result

After the end of a test you can print the results for your records by pressing the **Print** button (1). The quiet thermal printer prints out the example used in the previous paragraph in only six seconds.

While the printer is working, no key action is possible and the probe is inactive. figure **Id No:** Patient's Id number.

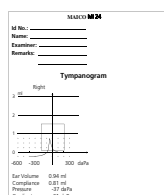

MAICO Race Car Tympanometer

Date: Actual test date.

Name: Name of the patient.

Examiner: Name of the examiner.

Remarks: Additional information about the test or patient.

All other values and the tympanogram correspond to those you have seen on the LCD (explained on the previous page under 4.5).

The “intelligent” printer control helps you save paper. It will only print out what was actually measured. The printout in the example above does not show reflex frequencies because only the tympanogram was measured.

If you have saved two tympanograms (for example, both the left and the right ear) they are printed side by side.

You can produce as many printouts as you want by pressing the **Print** button several times.

Figure 15
Printout of a normal tympanogram

4.9 How to delete the test results

By holding down the **L/R** key the measurement memory will be deleted. On the LCD the message **Delete all Data?** appears. Press **Enter** to delete all patient data. Then the LCD shows an empty measurement screen.

If you press the **Menu** button, you return to the measurement screen without deleting the measurement data.

Operating Instructions

Race Car Tympanometer

5 How to create a tympanogram with high probe tone

In addition to the standard 226 Hz probe tone tympanometry, a higher frequency probe tone may be selected by the user. A tympanogram recorded using the high probe tone may be better suited for screening newborns and provides more accurate results for those subjects.

5.1 To select high probe tone frequency

When the instrument is switched on, it automatically powers-up in the standard tympanometry mode (226Hz). In order to choose tympanometry with high probe tone (1000Hz), hold down the Reflex key for two seconds.

The screen for high probe tone tympanometry looks very similar to the normal tympanometry mode, however the following differences will appear on the screen:

- The scaling is now measured in mmho
- The pre-selected frequency (1000 Hz) is displayed in the upper left hand side of the screen

The tympanometry test with high probe tones is performed in the exact same way as a normal tympanometry test.

It is possible to perform normal tympanometry and high probe tone tympanometry in one test session and print the results for comparison. Now the next curve will be drawn automatically. Press Print and a printout presenting both curves will appear. **When the first tympanometry curve has been drawn, press the Reflex key for two seconds to switch to high probe tone tympanometry.**

Note: It is not possible to perform reflexes on the basis of a high probe tone tympanogram.

Operating Instructions

Race Car Tympanometer

6 How to measure the Stapedius reflex

6.1 The basics of the Stapedius reflex measurement

While tympanometry measures the change of the compliance caused by changing pressure in the outer auditory canal, the Stapedius reflex measurement works with a changing compliance caused by contraction of the Stapedius muscle in the middle ear. The contraction - called Stapedius reflex - causes a decrease in compliance and is caused by loud acoustic stimuli. Regardless whether the acoustic stimulus is active on the left or on the right or on both sides the Stapedius reflex is always binaural, i.e. it occurs in both ears at the same time. The Stapedius reflex is elicited by sound pressure levels between 70 and 105 dB in ears of adults with normal hearing.

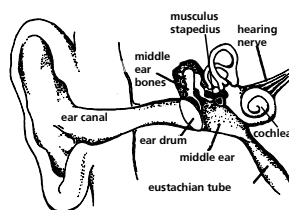

Figure 16
The middle ear

In the probe ear, the reflex method continuously measures the compliance at peak pressure as indicated by the tympanogram. Simultaneously the stimulus ear is irritated by the sound which causes the contraction of the Stapedius muscle.

The ipsilateral reflex measurement uses the same ear for the probe and the stimulus. The contra-lateral measurement uses different ears for the probe and the stimulus. The acoustic stimulus is applied to the ear opposite the probe ear.



Figure 17
Ipsilateral test

If the applied stimulus causes a reflex, the impedance measuring instrument registers a decrease in compliance in the "probe ear" which indicates a Stapedius reflex at the actual test frequency and the test level. The lowest test level at which a reflex occurs is called a reflex threshold and is shown in dB_{HL} (dB hearing level).

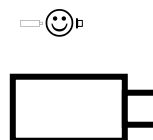

Figure 18
Contralateral test

6.2 Preparing the patient

In addition to the general introduction described in chapter 4.2, explain to the patient that loud test sounds will occur during the reflex measurement. It is very important that the patient does not move because a reflex can be registered with a change of compliance of 0.05 ml.

Operating Instructions

Race Car Tympanometer

6.3 Preparing the ipsilateral measurement

The LCD shows the empty tympanogram for the right ear and the control light of the probe is red.

To measure the left ear, change the side by pressing the **L/R** key or the probe button. The selected test ear shown in the middle-top of the LCD will change from **Right** to **Left** and the control light of the probe will turn blue.

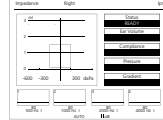

Turn the reflex measurement on by pressing the **Reflex** key. The word **Ipsi** must appear at the right top of the display. The sound stimuli for the reflex measurement are reproduced by the receiver integrated in the probe.

Figure 19
Display Tympanogram and reflex
(ready for measurement)

Set the desired intensity level with the **down/up** keys. On the LCD below the reflex boxes at the bottom, the selected level in dB (Figure 19: 80 dB) appears. The **"I"** indicates that an ipsilateral test is selected. You can choose between the fixed levels 70, 75, 80, 85, 90, 95 and 100 dB_{HL} and **Auto**.

If you choose **Auto**, the **RC** starts with the preset level and increases the level automatically until a reflex is registered or the maximum value is reached. You can choose your individual starting level and maximum level. If you have chosen a fixed level, the instrument measures only with this level.

Make sure the auditory canal is clear.

Choose the correct ear tip according to the size of the auditory canal and put it firmly onto the probe tip (see chapter 3.7 Figure 9).

Operating Instructions

Race Car Tympanometer

6.4 Taking the ipsilateral measurement

Carry out the measurement as described in chapter 4.4 "Recording the Tympanogram." The Stapedius reflex is measured after the measurement of the tympanogram. During the measurement of the Stapedius reflex the change of the compliance is represented in real time on the LCD. When the test is finished the curves for the changes of compliance at 500 Hz, 1000 Hz, 2000 Hz and 4000 Hz are shown in four separate graphs at the bottom of the measurement screen (see Figure 20). Below each curve is the test level where a Stapedius reflex was registered automatically. This is indicated by a **Pass** below the frequency. If no reflex was detected, a **Fail** is reported and the maximum level is shown.

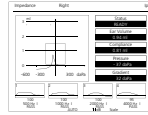

Figure 20
Example of a normal tympanogram
with ipsilateral reflex results

You can judge this by watching the real time graph if you have a real Stapedius reflex or only disturbance and artifacts. The lower dotted zero-line of a graph indicates the measured compliance without a test sound. All the positive or negative changes of compliance are shown as deviation from the zero-line. If a Stapedius reflex occurs, the compliance increases and the curve rises. The box which appears during the test symbolizes the threshold at which the **RC** accepts a change of compliance as a valid Stapedius reflex.

Operating Instructions

Race Car Tympanometer

6.5 Preparing the contralateral measurement (optional)

Switch on the contralateral reflex measurement by pressing the **Reflex** key (the word **Contra** must appear on the right top of the LCD). Here the highest fixed level is 110 dB_HL (with TDH 39 contra phone only).

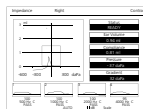

The contralateral measurement produces more reliable results because the receiver emitting the test signal and the probe measuring the compliance are separated.

If you are using an insert phone for contralateral measurement, put an appropriate ear tip on the insert phone and insert it in the contralateral ear.

Continue now as described previously for the ipsilateral measurement.

Figure 21
Example of a normal tympanogram with contralateral reflex results

6.6 How to interpret the reflex display

After having carried out a measurement you can read the recorded values on the LCD.

In addition to the tympanogram shown on the left side and the values shown on the right, the results of the reflex measurement appear in the lower part of the display. In the four boxes marked 1 to 4 the Stapedius response is shown graphically. Below each box the test level, the test frequency and the type of the test (**I**=ipsi, **C**=contralateral) are shown. The test result is also shown as **Pass** or **Fail**. In (Figure 22), for 500 Hz a Stapedius reflex was registered at 100 dB_HL and for 4 kHz at 95 dB_HL. If no reflex threshold is registered, **Fail** appears below the frequency.

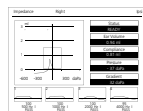

Correct interpretation of the reflex results should be made in conjunction with the tympanogram, the graphic reflex display, and other audiometric data.

Figure 22
Example of a normal tympanogram with ipsilateral reflex results

Operating Instructions

Race Car Tympanometer

6.7 How to print the test results

After a test, print the results for your documents by pressing the **Print** button. The printer prints out the example used in the previous paragraph in only 12 seconds.

While the printer is working no key action is possible and the probe is inactive.

In addition to printing the text as seen in chapter 4.6 the result of the reflex test is printed out.

The level value (dB_HL) at which a reflex had been measured appears below the graph.

If no reflex was registered, **Fail** is printed on the top of the graph behind the test frequency.

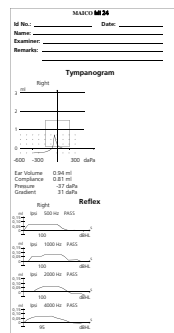

MAICO Race Car Tympanometer

Figure 23
Printout of a normal tympanogram
with ipsilateral reflex measurement

Operating Instructions

Race Car Tympanometer

7 Interpreting Test Results

7.1 Understanding the printout

The printout contains the following information:

- Ear volume
- Compliance
- Pressure
- Gradient
- Reflex Test Results (**Pass, Fail**) and **ipsi, contra** or **tympanogram** (depending on the test you have performed).

This information provides the data you need to interpret the test results.

A graph of the tympanogram is provided (Figure 24) to assist you in a visual interpretation of the test. This graph is a representation of the relative mobility of the middle ear system. The horizontal axis shows the changes in air pressure and the resulting mobility of the system. The compliance is recorded on the vertical axis. This mobility is expressed as a change in the volume of the ear canal in ml.

The reflex is shown in up to four graphs with time on the horizontal axis and the change of the compliance on the vertical axis.

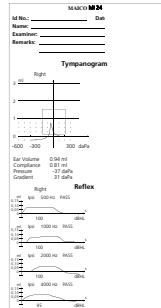

MAICO Race Car Tympanometer

Figure 24
Printout of a normal tympanogram

Operating Instructions

Race Car Tympanometer

7.2 Interpreting the tympanometric test result

As a general rule, values for ear canal volume should be between 0.2 and 2.0 ml (children and adults). A variance will be seen within this range depending on the age and ear structure of the person. For example, a 2.0 ml or larger reading in a small child could indicate a perforation in the tympanic membrane, while it may be a normal reading in an adult. You will become more familiar with the normal ranges when you use the instrument.

The normal range for compliance is 0.2 ml to approximately 1.8 ml. A compliance peak within the range indicates normal mobility of the middle ear system. A peak found outside of these limits may indicate one of several pathologies.

Middle ear pressure should be equivalent to ambient air pressure (0 daPa on an air pressure scale). Minor shifts of the peak compliance to the negative may occur with congestion and are rarely to the positive side. Establish criteria for abnormal negative pressure when you become more familiar with using the equipment. It is generally accepted that negative pressure of greater than -150 daPa indicates a referral for medical evaluation. A normal tympanogram is shown on the previous page in figure 24.

7.3 Abnormal Values

It is the purpose of this section to provide samples of tympanograms which reflect abnormal states of the middle ear mechanism. It is not the intention of this section to provide you with a complete guide to interpreting results. Complete information regarding pathologies and abnormal impedance testing can be found in the literature referenced.

A perforation in the tympanic membrane will cause a high ear canal volume measurement because the instrument will measure the volume of the entire middle ear space. The **RC** may refuse to run the test, with the probe indicating a volume out of tolerance by illuminating the red light, or a flat tympanogram will be recorded since no movement will occur with a change in air pressure.

An extremely flaccid tympanic membrane or an ossicular chain discontinuity will yield a very high peak compliance in the presence of normal middle ear pressure. Ear canal volume will be normal and the reflex will be absent.

A fixation of the ossicular chain, as in otosclerosis, will produce a tympanogram with very low compliance in the presence of normal middle ear air pressure. Ear canal volume is normal and the reflex is absent.

Operating Instructions

Race Car Tympanometer

Middle ear fluid such as in serous otitis media will yield a very flat tympanogram with no definite peak. A resolving case or beginning case may produce a reduced peak in the presence of severe negative middle ear pressure. The ear canal volume is normal and the reflex is either absent or at an elevated level.

Eustachian tube dysfunction in the absence of fluid will show a normal compliance curve, but it will be displayed to the negative side of the tympanogram. Ear canal volume will be normal and the reflex may be present, depending on the degree of involvement.

Operating Instructions

Race Car Tympanometer

8 How to test children

When practicing impedance measurement with small children, be aware of problems caused by the child being restless or afraid of the examination or reacting sensitively to the change of pressure and the loud test sound. There are also different conditions of the eardrum and the middle ear which do not appear in ears of adults.

It may be difficult to create a probe seal with restless children. If the child yawns or cries, the instrument will not have stable pressure in the outer auditory canal. In addition, speaking causes Stapedius muscle reflexes which lead to a change in the compliance of the eardrum.

The child should be made familiar with the surroundings and the ear being touched by the probe in order to carry out a successful impedance measurement. This could be done by getting in touch with the child and by playfully touching the ear with the probe. If you can touch the ear without problems, the child will normally accept the probe being inserted.

Operating Instructions Race Car Tympanometer

9 Additional Reading

Auditory Disorders: A Manual for Clinical Evaluation

Jerger, Susan, and James Jerger

Boston: College Hill Press, 1981

Handbook of Clinical Audiology

Katz, Jack

Baltimore: William & Wilkins, 1994

Roeser's Audiology Desk Reference

Roeser, Ross J.

New York / Stuttgart: Thieme, 1996

Auditory Diagnosis

Silam, Shlomo and Carol A. Silvermann

San Diego / London: Singular Publishing Group, 1997

Operating Instructions

Race Car Tympanometer

10 Individual Setup of the RC

The **RC** offers many options for the experienced user to adapt the instrument to individual demands.

The settings shown in the figures are the standard settings. If you have altered a value by accident you just have to return to the standard setting shown here and the instrument will work as before.

By pressing the **Menu** key (4) you can return from every sub-menu to the main menu tympanometry mode.

You can change the menu options with the **up/down/left/right** cursor keys. The menu option selected is highlighted on the LCD (**Setup** in Figure 25). Accept the chosen menu option by pressing **Enter**.

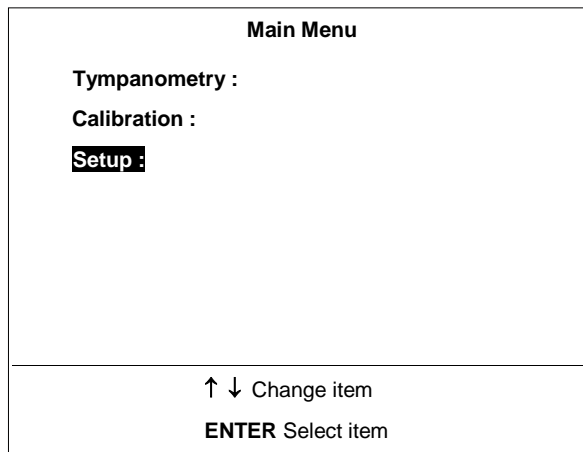

Figure 25
RC main menu

10.1 The setup menu

Select the menu option **Setup** as illustrated in (Figure 25) and the main setup menu will appear on the LCD. You can make different settings for the measurement of the tympanogram and the Stapedius reflex as well as the instrument setup (for example the contrast of the LCD). All your settings are saved permanently until you change them again. The settings also remain when the instrument is switched off.

Operating Instructions

Race Car Tympanometer

10.2 The tympanometer setup

Select the menu option **Tympanometry Setup Menu** as illustrated in figure 26 and the Tympanometer Setup Menu will appear on the LCD.

Change the menu options with the **up/down** cursor keys.

Change the displayed item with the **left/right** cursor keys. The following settings are possible:

Pump speed:

With this option you can set the measurement speed. With **Automatic**, the pump speed adjusts automatically to the test conditions. It is possible to choose **Minimum, Medium** or **Maximum** as well. A lower pump speed creates a higher precision of the measurement but needs more test time.

Display limits:

On displays normative boundaries in the tympanogram test Screen. **Off** turns it off.

Press. Limit hi:

With this option you can set the right limit of the normative box display on the tympanogram test screen. Values can be set between 0 daPa and +200 daPa in steps of 25 daPa.

Press. Limit lo:

With this option you can set the left limit of the normative box display on the tympanogram test screen. Values can be set between -400 daPa and -25 daPa in steps of 25 daPa.

Comp. limit hi:

With this option you can set the upper limit of the normative box display on the tympanogram test screen. Values can be set between 0.1 ml and 3 ml in steps of 0.1 ml.

Comp. limit lo:

With this option you can set the lower limit of the normative box display on the tympanogram test screen. Values can be set between 0.1 ml and 1.0 ml in steps of 0.1 ml. To leave the **Tympanometry Setup Menu** press the **Menu** button.

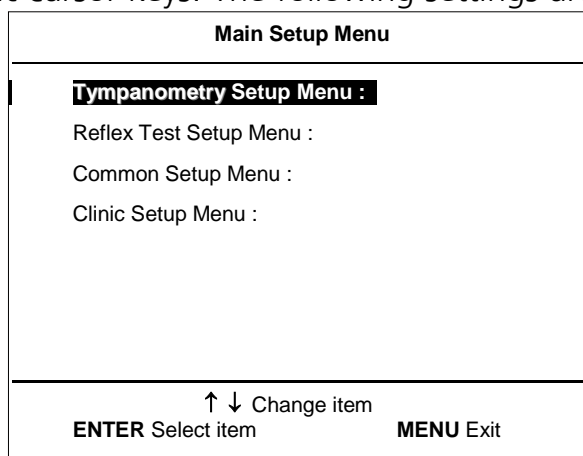

Figure 26
RC setup menu

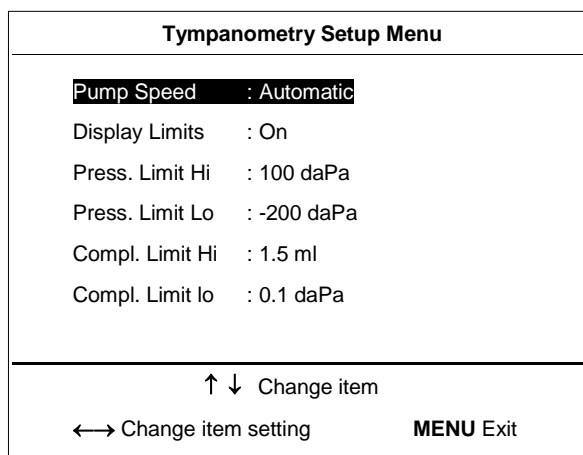

Figure 27
RC Tympanometer Setup Menu
(pump speed selected)
(display limits setup selected)

Operating Instructions

Race Car Tympanometer

10.3 The Setup menu for Reflex Test

Select the menu option **Reflex Test Setup Menu** from the main setup menu as described before for the **Tympanometry Setup Menu**. The reflex setup menu will appear on the LCD.

The reflex setup menu offers the following options:

Auto start dB :

With this option you can choose the starting acoustic pressure level if the automatic identification of the reflex threshold is switched on. You can choose the acoustic pressure levels from 70 dB_{HL} to 100 dB_{HL} in steps of 5 dB.

Auto maximum dB:

With this option you can choose the maximum acoustic pressure level the **RC** uses if the automatic identification of the reflex threshold is switched on. You can choose maximum levels from 80 dB_{HL} to 110 dB_{HL} in steps of 5 dB.

Reflex sensitivity:

With this option, select the sensitivity of the Stapedius reflex detection.

The **Sensitive** setting will achieve a **Pass** test result with a very small compliance change. **(i.e. 0.03ml)**

The **Normal** setting is the default setting. **(i.e. 0.05ml)**

With the **Robust** setting, a larger compliance change is needed to detect a **Pass**. **(i.e. 0.08ml)**

Print graphic:

With this option the printout of the graphic reflex display can be turned on or off for documentation.

500 Hz : The Stapedius reflex test can be turned on and off with this option.

1000 Hz : The Stapedius reflex test can be turned on and off with this option.

2000 Hz : The Stapedius reflex test can be turned on and off with this option.

4000 Hz : The Stapedius reflex test can be turned on and off with this option.

To leave the Setup Menu for reflex, press the **Menu** button.

Reflex Test Setup Menu	
Auto. Start dB	: 80
Auto. Maximum dB	: 105
Reflex sensitivity	: Normal
Print graphic	: On
500 Hz	: On
1000 Hz	: On
2000 Hz	: On
4000 Hz	: On

↑ ↓ Change item

← → Change item setting MENU Exit

Figure 28
RC Reflex Setup Menu
(auto start dB setup selected)

Operating Instructions

Race Car Tympanometer

10.4 The Common Setup Menu

Select the menu option **Common Setup Menu** from the main setup menu.

The common setup menu offers the following options.

Power-up:

Choose the test mode of the **RC** after switching on. With the **Tymp** setting, only tympanometry is tested after power-up.

With **Tymp and Reflex**, tympanometry and reflex are tested after power-up.

Baud Rate:

Set the transmission speed of the serial data interface. Possible settings are **57600** Baud or **38400** Baud.

Remote Switch:

Change the function of the probe button. You can choose between:

L/R: the test ear can be selected with the probe button.

Pause: the test can be paused and restarted with the probe button.

L/R or Pause: both the test ear and the test can be selected, paused and restarted with the probe button (M) or off.

Subject Data Printout :

Turn the printout of the headline (data entry area at the top) on or off.

Clinic Data Printout :

If you entered your clinic data the printout of the entered data can be switched on and off with this option.

Print after test :

With this option you enable an automatic printout after you have finished a test by setting it on. With the setting off, the printout will be processed after you press the **Print** button.

Race Car:

Turn on Race Car animation during tympanometry test by selecting **ON**. If this feature is turned **OFF**, only the traditional tympanogram will be shown during the test.

Common Setup Menu	
Power-up	: Tymp and Reflex
Baud Rate	: 57600
Remote switch	: L/R
Subject Data Printout	: On
Clinic Data Printout	: On
Print after Test	: Off
Race Car	: On
Language	: English
Display adjust	:

↑ ↓ Change item

Figure 29
RC Reflex Setup Menu
(auto start dB setup selected)

Operating Instructions

Race Car Tympanometer

Language :

You can choose one of the following languages: German, French, English or Spanish for the text on the LCD and the printout. After selection all the texts appear in the chosen language.

Display adjust :

The contrast of the LCD can be changed with this option.

10.5 Insert your personal printout data

Select the menu option **Clinic Setup Menu** from the main setup menu, see figure 28, to enter all required data for your clinic. The data will be printed out with the test results and the patient data.

Operating Instructions

Race Car Tympanometer

11 Care and maintenance of the instrument

Disconnect the power plug before cleaning.

To clean the instrument, probe, contralateral receiver and other accessories use a soft, damp cloth (use warm soapy water; no liquids containing alcohol or ammonia should be used) to gently wipe the area clean.

During cleaning, please ensure that no liquid runs into the switches, level control or probe openings.

Operating Instructions

Race Car Tympanometer

12 How to change the printer paper

At the right side of the housing, pull the printer cover up using its finger recess in the front of the printer cover.

Remove the printer cover.

Remove the empty paper roll.

Place the new paper roll in the paper compartment in such a way that the paper unrolls from the **bottom side** of the roll.

Pull the blue lever, which is located on the right front of the printer, forward into position.

The paper must feed from the bottom because it is only coated on one side. **If it is inserted wrong, no printout will be visible!**

Gently insert the paper end in between the rubber roll and the black plastic part at the rear of the printer.

Feed the printer paper until it appears from the upper part of the rubber roll.

Feed about 4 – 5 inches of paper from the roll.

Push the blue lever back into its backward position.

Guide the paper end through the paper slot of the printer cover.

Close the printer cover by putting the two guide rails at the end of the printer cover into their appropriate slots in the paper compartment of the housing of the **RC**. Press the front of the printer cover down until it fastens.

You are now ready to print.

Operating Instructions

Race Car Tympanometer

13 Warranty, maintenance and after-sales service

13.1 Warranty

This warranty is extended to the original purchaser of the **RC** by Maico, through the authorized Special Instrument Distributor from whom it was purchased, and covers defects in material and workmanship for a period of one year from date of delivery of the **RC**.

Should the Maico **RC** require service due to a defect in material or workmanship, Maico, at its option, will repair or replace the instrument at no charge except for transportation to and from the point of service. It is the purchaser's responsibility to return the **RC** to the Maico Special Instrument Distributor from whom it was purchased or directly to Maico after receiving a return authorization.

This warranty does not cover breakage or failure caused by tampering, misuse, carelessness, accident or modification. The warranty is void if the instrument is serviced by other than an authorized Maico Special Instrument Service Center.

NOTE:

Specifications in this manual are in effect at the time of printing. Maico reserves the right to modify or change specifications or design at any time without notice or incurring obligation.

WARNING:

The **Maico RC** is designed to be used with a hospital grade outlet. Injury to personnel or damage to equipment can result when a three-prong to two-prong adapter is connected between the power plug and an AC outlet or extension cord.

Operating Instructions

Race Car Tympanometer

13.2 Maintenance

The **RC** is designed to require minimal maintenance and should provide you with years of trouble-free use. The following suggestions may assist you in avoiding and/or solving problems.

Calibration:

The optimum length of time between recalibrations for impedance meters or audiometers varies, depending upon the treatment given the instrument and the headphones/probe. It is recommended that the instrument have a laboratory calibration at least once every year. Since rough handling, such as dropping the probe, can easily cause calibration errors it is advisable to establish a biological calibration check as soon as you receive the instrument.

Should you feel at a later date that the impedance or audiometer's calibration may be in error, perform a biological check on a known ear. If all retests show major changes, calibration is probably in error.

All repair and recalibration should be done at an authorized Maico Special Instruments Distributor service center. This assures the use of quality materials by trained and experienced technicians using the proper, accurate equipment.

Maico Special Instruments Distributors are located in major cities throughout the world. To minimize costs and time delays, contact the Distributor that you purchased the instrument from. If you don't know who that is, or need to find the Distributor closest to you, contact the factory at:

Maico Diagnostics
10393 West 70th St
Eden Prairie, MN 55344
Toll free 888-941-4201
Phone 952-941-4200
Fax 952-903-4200

Customers outside of North America and South America may contact:

Maico Diagnostic GmbH
Sickingenstr 70/71
10587 Berlin, Germany
Phone ++030 70 71 46 50
Fax ++030 70 71 46 99

Operating Instructions

Race Car Tympanometer

Care of eartips:

The eartips supplied with your instrument are latex-free silicone rubber and can be cleaned with a mild soap and water, chlorine bleach or with alcohol. Dry the tips thoroughly before replacing them on the probe.

Shipping instructions for recalibration or repair

In the event it becomes necessary to return the instrument for recalibration or repair, please follow these instructions:

1. Place the instrument in the original shipping carton, using the packaging provided. Be sure to include all accessories, as they are required for proper calibration.
2. Enclose an explanatory letter describing the service you require, carefully detailing any operational problems. Be sure to include your name, phone number, the serial number and your full return address for return shipping.
3. Ship, prepaid, to your Maico Special Instrument service center.

NOTE: Warranty service is provided by your authorized Maico Special Instruments Distributor.

**DO NOT ATTEMPT TO REMOVE THE INSTRUMENT CASE YOURSELF.
THIS SHOULD ONLY BE DONE BY AN AUTHORIZED MAICO SERVICE TECHNICIAN.**

Operating Instructions

Race Car Tympanometer

14 Safety regulations

14.1 Electrical safety:

The **RC** tympanometer is constructed to comply with protection class II of the international standard IEC 601-1 (EN 60601-1).

The instruments are not intended for operation in areas with an explosion hazard.

14.2 Measuring accuracy:

To guarantee that the tympanometer works properly, the instrument has to be checked and calibrated at least once a year.

The service and calibration must be performed by an authorized service center.

The use of non-calibrated tympanometers is not allowed.

14.3 Device control:

The user of the instrument should perform a subjective instrument check once a week. This check can be completed following the list for subjective instrument check (see next page). For your own security, you should copy the enclosed list, fill it in once a week and store it in your files.

Operating Instructions

Race Car Tympanometer

15 Checklist for subjective device control

According to the manufacturer requirements, the user should test the instrument once a week. This is to find errors immediately and to avoid inaccurate test results. This test should test tympanogram and reflex with an otologic normal person and compare the results with earlier measurements. The printout should be filed together with the subjective test protocol to document the instrument test. The test person should be healthy (no otitis etc.) and should not be exposed to loud noise for at least 12 hours before the test. The instrument must be calibrated according to chapter 3.5 of the operating instructions.

Instrument type:

Serial No.:

Test person:

Connectors and cables OK?

Instrument and probe?

Is the green light  of the probe blinking?

Probe tip and ear tip clean?

Are all controls easy to use?

Are the test signals clear and non-distorted?

Reflex test	500 Hz	1000 Hz	2000 Hz	4000 Hz
right ear				
90 dBHL				
Reflex test	500 Hz	1000 Hz	2000 Hz	4000 Hz
left ear				
90 dBHL				

If significant differences or damages are found, please send in for service repair.

Tested by:

Date:

Operating Instructions

Race Car Tympanometer

16 Technical Data and Accessories

Impedance measurement:

Type: Clas 2 acc. to ANSI S3.39

Tympanometer:

Test frequency: 226 Hz \pm 1%

Test level: 85 dB_{SPL} in 2 cm³

Pressure range: +200 to -400 daPa

Volume range: 0.1 to 6.0 ml

Accuracy: \pm 5 % or \pm 10 daPa

Test time: Less then 3 seconds typical

Compliance range: 0.2 to 3.0 ml

Reflex measurement:

Test frequencies: 500 Hz, 1 kHz, 2 kHz, 4 kHz \pm 2%

Test method: ipsilateral, contralateral (optional)

Test level ipsilateral: 70 dB_{HL} to 105 dB_{HL}

(High freq. option) (for 4 kHz to 105 dB_{HL})

Test level contralat.: 70 dB_{HL} to 110 dB_{HL}

(High freq. option) (for 4 kHz to 105 dB_{HL})

Attack/release time: Typical 10 ms

ON/OFF Ratio: Greater than 70 dB

Pressure at test: Pressure @ max. compliance

General:

Memory: Storage of two complete test result sets

LCD-display: Graphical display of the tympanograms and the reflex curves

Numeric display of max. compliance, pressure at max. Compliance, canal volume, gradient and reflex thresholds

Printer: Thermal printer, paper roll width 110 mm

Printing time: Between 4 seconds (one tympanogram) and 12 seconds (tympanogram and reflex for both ears)

Voltage: 96 - 240 V / 50/60 Hz

Power consumption: approximately 65 VA

Operating Instructions

Race Car Tympanometer

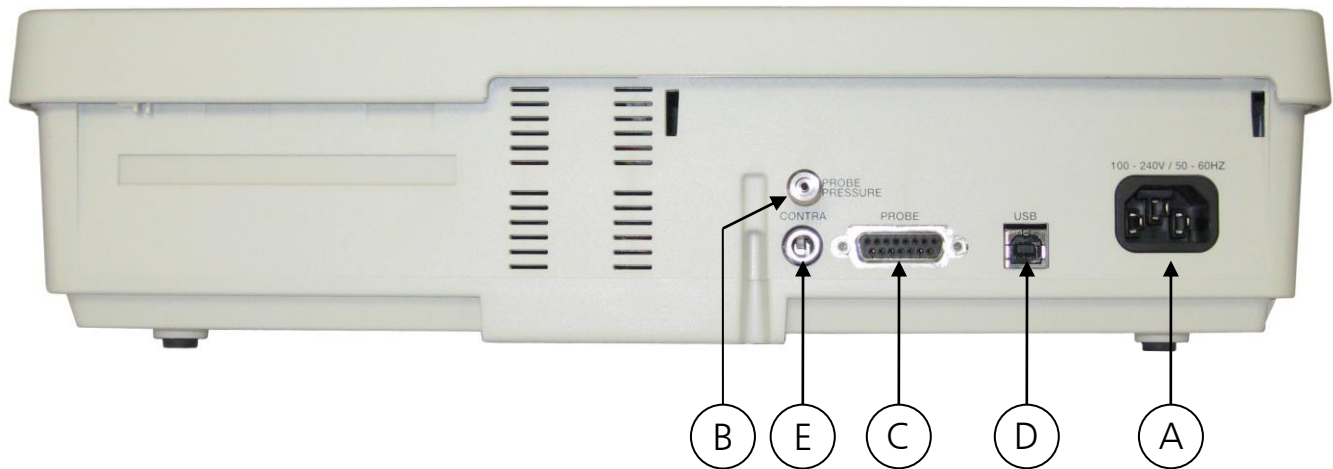

Figure 4
Connectors on the rear of the RC

Connection plugs:

- A. Power socket
- B. Pressure tube
- C. Probe
- D. USB PC-interface
- E. Contra lateral phone (option)

Warm up time: less than 10 minutes after power on

Environment conditions: + 15 to + 35 °C / + 59 to + 95 °F (operation)
+ 5 to + 50 °C / + 41 to + 122 °F (storage)
Maximum humidity 90 % (storage and operation)

Dimensions: 15 ¼" W x 11 ½" D x 4 ¼" H
(39 cm W x 29 cm D x 11 cm H)

Weight: approximately 5.5 Lbs (2.6 kg)

Operating Instructions

Race Car Tympanometer

Accessories:

Standard:	1 hand-held probe
	1 power cable
	1 set of ear tips
	1 calibration cavities (cavities 5ml, 2ml, 0.5ml)
	1 printer paper roll (for app. 350 printouts)

Consumable:	1 roll printer paper	Part No. 5529
	4 pc. ear tips yellow (7 mm)	Part No. 6643
	4 pc. ear tips green (9 mm)	Part No. 6644
	4 pc. ear tips white (11 mm)	Part No. 6645
	4 pc. ear tips yellow (13 mm)	Part No. 6646
	4 pc. ear tips green (15 mm)	Part No. 6647
	4 pc. ear tips blue (18 mm)	Part No. 6648

Specifications are subject to change.



MAICO Diagnostics
10393 West 70th St
Eden Prairie, MN 55344
Tel.: 888.941.4201
Fax: 952.278.4481
E-mail: info@maico-diagnostics.com
Internet: www.maico-diagnostics.com

