

---

# User's Manual

## Confocal Scanner Unit CSU-X1

IM 85A7C25-02E

---



## *TABLE OF CONTENT*

<b>1</b>	<b><i>Safety Precautions</i></b> .....	<b>5</b>
1.1	<b>Introduction</b> .....	<b>5</b>
1.2	<b>CAUTION</b> .....	<b>5</b>
1.3	<b>History</b> .....	<b>5</b>
1.4	<b>General Safety Precautions</b> .....	<b>6</b>
1.5	<b>Laser safety Precautions</b> .....	<b>8</b>
1.5.1	Laser Safety Standards .....	8
1.5.2	About the Class 3B Laser .....	11
1.5.3	Safety Precautions .....	11
<b>2</b>	<b><i>Product Overview</i></b> .....	<b>18</b>
2.1	<b>Principle of the Confocal Microscope</b> .....	<b>18</b>
2.2	<b>Structure and Features of the CSU-X1</b> .....	<b>19</b>
2.3	<b>Description of CSU-X1</b> .....	<b>20</b>
2.3.1	CSU-X1-M1.....	21
2.3.2	CSU-X1-M2.....	22
2.3.3	CSU-X1-A1 .....	23
2.3.4	CSU-X1-A2 .....	24
2.3.5	CSU-X1-A3 .....	25
<b>3</b>	<b><i>Before Using the Unit</i></b> .....	<b>26</b>
3.1	<b>Packing List</b> .....	<b>26</b>
3.2	<b>Option List</b> .....	<b>27</b>
3.2.1	Filter wheel control unit (CSU-X1CU-F1).....	27
3.2.2	Filter wheel (CSU-X1FW):.....	27
3.2.3	Bright Field Control unit (CSU-X1CU-B1) .....	27
3.3	<b>Installation</b> .....	<b>28</b>
3.3.1	Installation of Microscope.....	28
3.3.2	Installation of Laser System and Adjustment of Fiber Coupler .....	31
3.3.3	Installation of CSU-X1.....	32
3.3.4	Connection Diagram .....	37
3.3.5	Installation of Camera.....	39
3.3.6	Power witch .....	39

3.3.7	Power Off .....	40
<b>4</b>	<b><i>Name and Function</i></b> .....	<b>41</b>
4.1	M1 Model .....	41
4.2	M2 Model .....	44
4.3	A1 Model .....	44
4.4	A2 Model .....	45
4.5	A3 Model .....	45
<b>5</b>	<b><i>Maintenance</i></b> .....	<b>46</b>
5.1	BA Filter Exchange .....	46
5.2	Dichroic Mirror Unit Exchange.....	47
<b>6</b>	<b><i>Trouble Shooting</i></b> .....	<b>48</b>
6.1	Microscope, Laser and fiber coupler.....	48
6.2	CSU-X1.....	48
<b>7</b>	<b><i>Specification</i></b> .....	<b>50</b>
7.1	<b>Product Specifications</b> .....	<b>50</b>
7.1.1	Specifications of CSU-X1 unit.....	50
7.1.2	Electrical Specifications of CSU-X1 unit.....	53
7.1.3	Specifications of Control unit .....	54
7.1.4	Specifications of Filter Wheel.....	55
7.1.5	Environment.....	56
7.1.6	Conformity .....	57
7.1.7	Global Environment Action.....	57
7.2	<b>Model and Suffix Code (MS Code)</b> .....	<b>58</b>
7.3	<b>Dimension</b> .....	<b>60</b>
7.3.1	CSU-X1-A1 .....	60
7.3.2	CSU-X1-A2 .....	61
7.3.3	CSU-X1-A3 .....	62
7.3.4	CSU-X1-M1.....	63
7.3.5	CSU-X1-M2.....	64
7.3.6	CSU-X1CU.....	65
7.3.7	CSU-X1FW .....	65

7.4	Control Signal.....	66
8	<i>Command list</i> .....	73
9	<i>Warranty</i> .....	75



# 1 Safety Precautions

## 1.1 Introduction

Thank you so much for purchasing the CSU-X1. This manual covers the features, operation methods and procedures, safety and handling precautions of the CSU-X1.

Before you start to use this instrument, read this manual thoroughly and operate the instrument in a proper manner.

After reading through, please keep this manual in a safe place for future quick reference.

## 1.2 CAUTION

No part of the user's manuals may be transferred or reproduced without prior written consent from Yokogawa.

Yokogawa continues to improve the product's performance and features, and for this reason, the specifications and information herein are subject to change at any time and without notice.

The authors and publishers of this manual have used their best efforts in preparing this document, but make no representation or warranties with respect to the accuracy, applicability, fitness, or completeness of the contents of this manual. If you have noticed any problems or have any suggestions for the manual, please contact us.

To maintain long-term, stable performance of the product, please observe the operation instructions in this manual.

## 1.3 History

1<sup>st</sup> Edition: September, 2007

## 1.4 General Safety Precautions

For the protection and safe use of this instrument, be sure to observe the instructions on safety described in this manual when handling this instrument. If you use the instrument in a manner not specified in this manual, the protection provided by this instrument may be impaired. In addition, Yokogawa Electric Corporation assumes no liability for the customer's failure to comply with these requirements.

The following safety precaution symbols are attached to the instrument:



Both of the above two symbols indicate that important content is mentioned. The symbols are given wherever you are required to refer to the manual in order to avoid personal injury and/or damage to the instrument.

The following safety precaution symbols are used in this manual.



This symbol indicates that the operator must observe the explanation in the user's manual in order to avoid serious injury or death and/or damage to the instrument.



This symbol indicates that the operator must observe the explanation in the user's manual in order to avoid minor injury and/or damage to the instrument.



To reduce the risk of bodily injury of personnel such as electric shock or and/or damage to the instrument, please comply the following precautions:

 **WARNING**

Power supply

Please make sure the source voltage matches the voltage of the power supply before turning on the power.

The CSU-X1 is classified as a laser hazard CLASS 3B instrument in accordance with WHO regulations. Please comply with the remarks on laser safety precautions described in the next chapter of this manual.

 **CAUTION**

The CSU-X1 is used in combination with a microscope, laser system, camera, and other peripheral instruments. Please read carefully instruction manuals of each instrument, and follow safety precautions.

Please use input/output terminals of the CSU-X1 within the range of specification as stated in this manual.

The CSU-X1 is a precision optical instrument. Please do not install the CSU-X1 system under inappropriate circumstances, such as vibrating conditions, dusty place, very humid and/or high temperature room, drastic change in the room temperature, corrosive or inflammable atmosphere, etc.

Do not touch inside the CSU-X1. Unauthorized open/touch inside the CSU-X1 may cause mechanical and optical damages, and may cause serious damages.

Do not touch and soil the surface of the lenses inside the camera port adapter and C mount port of the CSU-X1 at the time of installation or storing..

In the case of malfunction, please do not open the CSU-X1 but consult Yokogawa Electric Corporation, or your local representative for proper advice and repair.

## 1.5 Laser safety Precautions

Laser products are classified on the basis of their laser beam wavelengths and power characteristics, and a common set of safety standards is applied to the products in each class. The CSU-X1 is classified as a laser hazard CLASS 3B instrument in accordance with WHO regulations, which indicates that it is capable of producing skin or eye damage if used improperly. Direct viewing into the laser beam or the viewing of reflected beams must strictly be prevented. The WHO recommendations concerning health and industrial protection when handling laser instruments must strictly be observed. Before operating the CSU-X1, please read the following to become familiar with its safety control, markings, and warnings.

### 1.5.1 Laser Safety Standards

The CSU-X1 is designed in compliance with the Emission Safety Guideline of Laser Product of Japanese Industrial Standard (JIS C 6802). For safe use of the CSU-X1, the following considerations are made:

#### Warning labels

You must attach the warning labels at appropriate positions indicated below either on the CSU-X1 or on the microscope at installation, and strictly follow the warnings when using the CSU-X1, for your own safety. Figure 1-1 shows warning labels for safe use of the laser product to be attached to this product, and the microscope to be used in combination with it. Figure 1-2 shows the positions to attach the warning labels for the CSU-X1 and the filter wheel. Figure 1-3 shows the positions to which the warning labels for the microscope to be used in combination with this instrument should be attached.

Warning label (1)  
M3916LK(E)

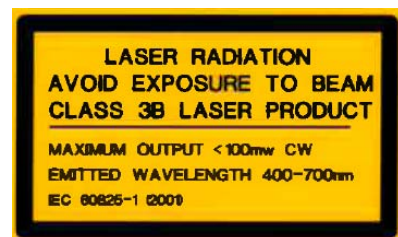

Warning label (2)  
M3916LL(E)



Warning label (3)  
M3916LM(E)



Warning label (4)  
D8953RH(E)

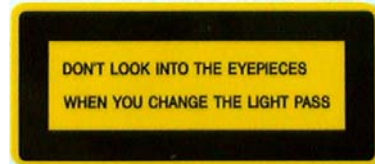

Warning label (5)  
M3916MB



Warning label (6)  
M3916XE



Figure1-1 Warning labels

(1) Warning label (1)

Warning sign to indicate this product belongs to the Class 3B laser product, and indicates the product's wavelength, maximum laser output power and laser class.

(2) Warning label (2)

Warning sign to instruct the operator must turn the laser off when he removes the FC connector.

(3) Warning label(3)

Warning sign to indicate the laser aperture must be closed when the laser is on.

(4) Warning label (4) : For Direct view Port (Option)

Warning sign to instruct the operator avoid looking into the eyepiece of microscope when exchanging the light path between confocal and non-confocal observation to avoid laser exposure through the eyepiece.

(5) Warning label (5)

Warning sign to advise the necessity to use the laser in compliance with the class 3B laser safety precautions. Specifically, it is necessary to avoid direct exposure of the laser beam on the skin or eyes. Do not touch or look into the laser beam.

(6) Warning label (6)

Warning sign to indicate the operator must never insert the fingers or hand in the filter wheel holes while operation.

(7) Laser key switch

The laser power supply used for CSU-X1 system employs a key switch for your safety. The key switch is to turn off laser emission into the CSU-X1. For details, see the user's manual of the laser system you are using.

(8) Shutter

The shutter is for the incident laser beam. You may select full-open or close. For non-confocal observation, always keep the shutter closed. Red LED light on the operation panel of CSU-X1 will be OFF when the shutter is closed.

(9) Interlock

When you use the CSU-X1 without control unit (CSU-X1CU-F1), insert the interlock key into the EXT CONTROL / INTERLOCK connector before turning on the unit. This will disengage the interlock circuit, and you will be able to manually open/close the shutter from the operation panel. If you use the control unit (CSU-X1CU-F1), insert the interlock key into the EXT INTERFACE1 (at the back of the control unit). After turn on the CSU-X1 unit, you will be able to open/close the shutter via operation panel or control unit.

## 1.5.2 About the Class 3B Laser

Laser products are classified by their acceptable exposure limit ( AEL) based on the laser beam wavelengths and power characteristics, and a common set of safety standards is applied to the products in each class. The CSU-X1 is classified as a laser hazard CLASS 3B instrument in accordance with WHO regulations, which indicates that it is capable of producing skin or eye damage if used improperly. Direct viewing into the laser beam or the viewing of reflected beams must strictly be prevented. The WHO recommendations concerning health and industrial protection when handling laser instruments must strictly be observed..

## 1.5.3 Safety Precautions

### (1) Controlled access area

The laser products shall be operated within controlled access areas.

### (2) Warning Signs

At the entrance of the controlled access areas, post laser warning signs.

### (3) Surface reflection

Metallic and other lustrous and reflective surfaces may reflect laser beams. Make sure that no unexpected reflection of laser beams may occur.

### (4) Beam path

The laser beam coming through the optical fiber is injected into the CSU-X1 via an FC connector. Never remove the FC connector connected to the CSU-X1 unless the outgoing laser beam is stopped. Do not directly view or touch the laser beam source, optical fiber, or laser beam coming out of the CSU-X1.

### (5) Protective glasses

When you want to observe the direct light or reflected light, protect your eyes by wearing protective glasses.

### (6) Key control of laser sources

Power supply of laser system used for laser confocal scanner system can be turned on/off by using a key provided with the laser system. When you don't use the laser system, please remove the laser key and store it in a safe place so that unauthorized persons are not able to operate the laser. For details, refer to the user's manual of the laser system you are using in combination of the CSU-X1.

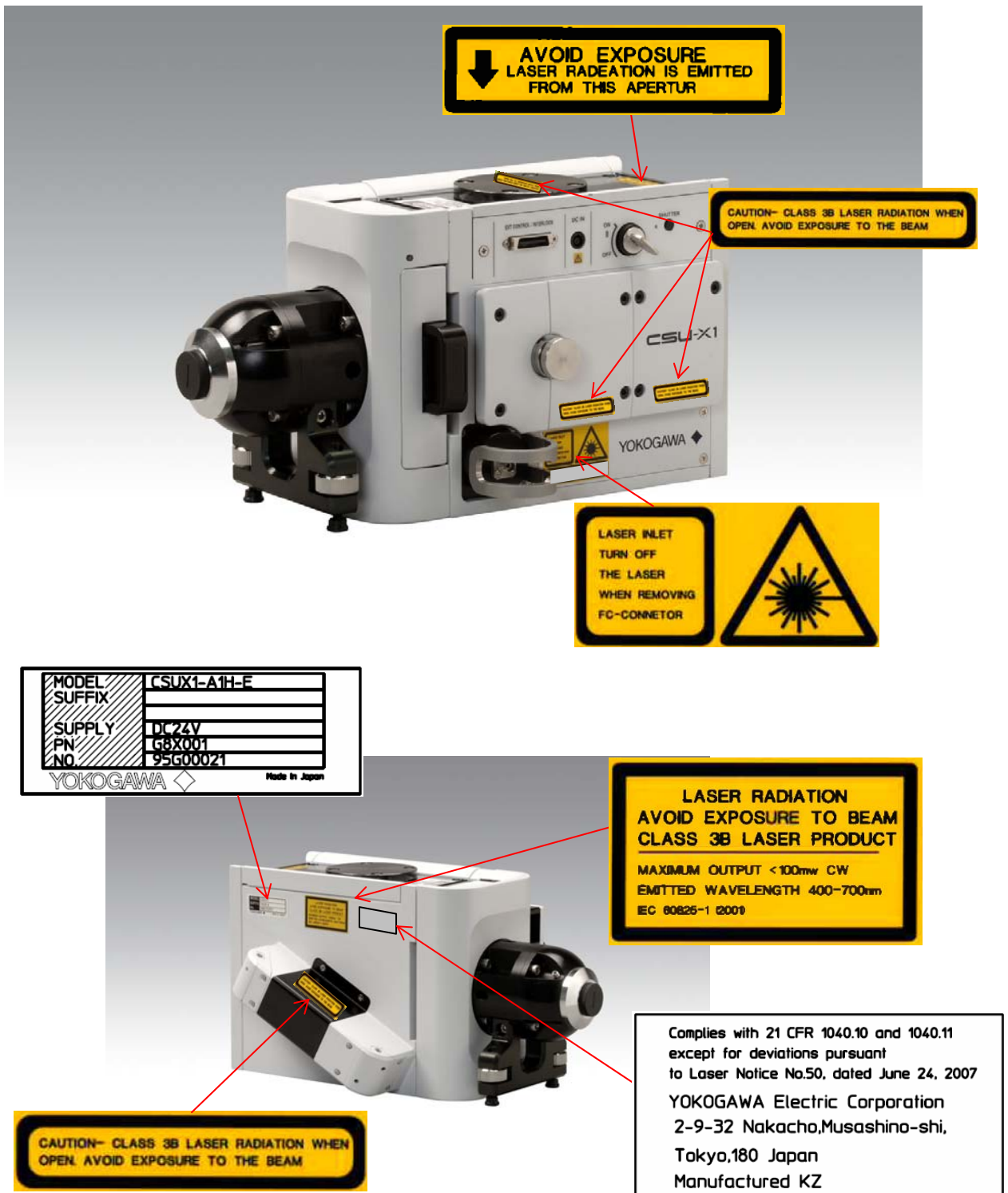

Figure 1-2 Positions to attach warning labels to CSU-X1-M1-E  
(Labels are the same with the A1 model.)



MODEL	CSUX1-A1H-E
SUFFIX	
SUPPLY	DC 24V
PN	GBX001
NO.	95G00021
YOKOGAWA  Made in Japan	

**LASER RADIATION**  
**AVOID EXPOSURE TO BEAM**  
**CLASS 3B LASER PRODUCT**

MAXIMUM OUTPUT <100mw CW  
 EMITTED WAVELENGTH 400-700nm  
 IEC 60826-1 (2001)

Complies with 21 CFR 1040.10 and 1040.11 except for deviations pursuant to Laser Notice No.50, dated June 24, 2007

YOKOGAWA Electric Corporation  
 2-9-32 Nakacho, Musashino-shi,  
 Tokyo, 180 Japan  
 Manufactured KZ

CAUTION- CLASS 3B LASER RADIATION WHEN OPEN. AVOID EXPOSURE TO THE BEAM

Figure 1-3 Positions to attach warning labels to CSU-X1-M2-E

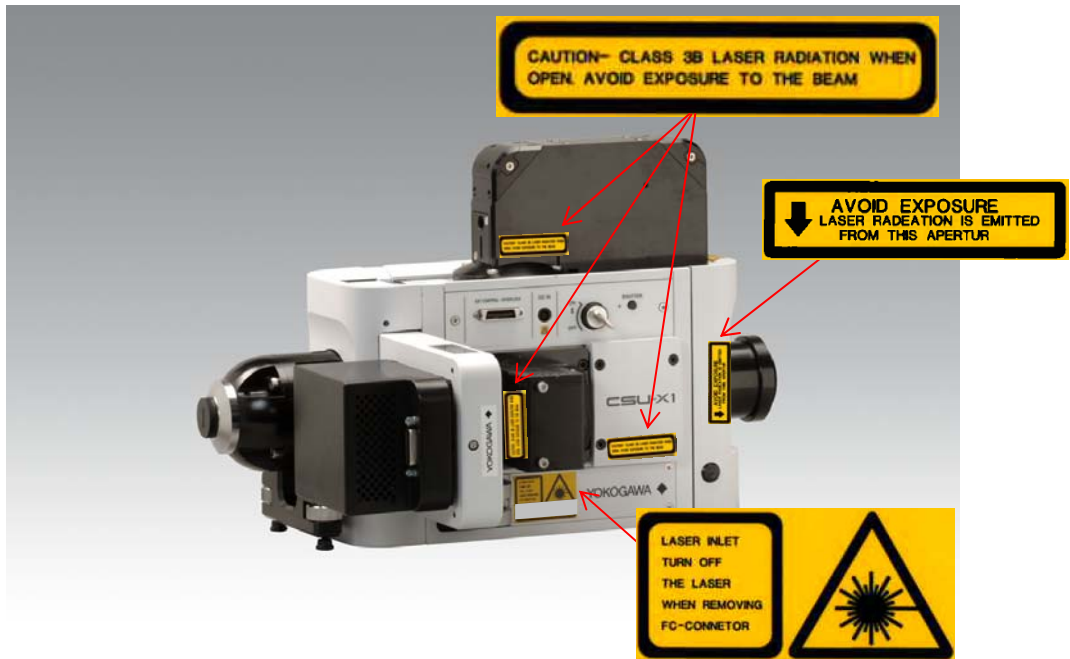

MODEL	CSUX1-A1H-E
SUFFIX	
SUPPLY	DC24V
PN	G8X001
NO.	95G00021
YOKOGAWA  Made in Japan	

**LASER RADIATION**  
**AVOID EXPOSURE TO BEAM**  
**CLASS 3B LASER PRODUCT**

MAXIMUM OUTPUT < 100mw CW  
 EMITTED WAVELENGTH 400-700nm  
 IEC 60826-1 (2001)

Complies with 21 CFR 1040.10 and 1040.11 except for deviations pursuant to Laser Notice No.50, dated June 24, 2007  
 YOKOGAWA Electric Corporation  
 2-9-32 Nakacho, Musashino-shi,  
 Tokyo, 180 Japan  
 Manufactured KZ



Figure 1-4 Positions to attach warning labels to CSU-X1-A2-E



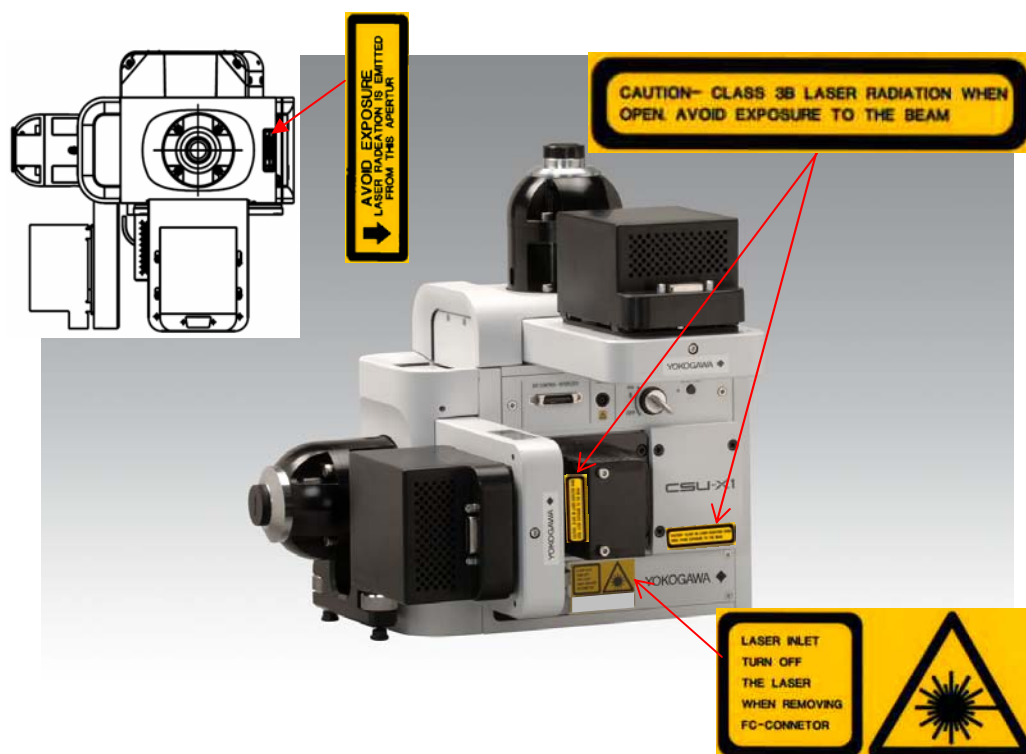

MODEL	CSUX1-A1H-E
SUFFIX	
SUPPLY	DC24V
PN	G8X001
NO.	95G00021
YOKOGAWA  Made in Japan	

**LASER RADIATION**  
**AVOID EXPOSURE TO BEAM**  
**CLASS 3B LASER PRODUCT**

MAXIMUM OUTPUT <100mw CW  
EMITTED WAVELENGTH 400-700nm  
IEC 60826-1 (2009)

Complies with 21 CFR 1040.10 and 1040.11  
except for deviations pursuant  
to Laser Notice No.50, dated June 24, 2007  
YOKOGAWA Electric Corporation  
2-9-32 Nakacho, Musashino-shi,  
Tokyo, 180 Japan  
Manufactured KZ



Figure 1-5 Positions to attach warning labels to CSU-X1-A3-E



CSU-X1-M1

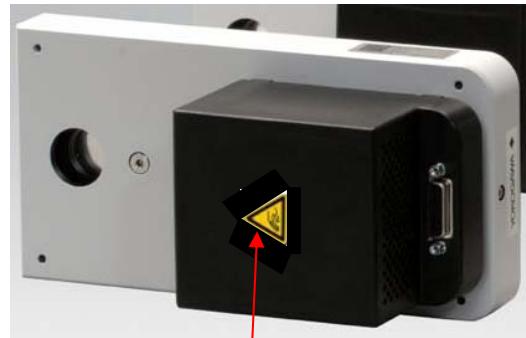

CSU-X1-FW



CSU-X1-A2



CSU-X1-A3



Figure 1-6 Positions to attach warning labels (6)

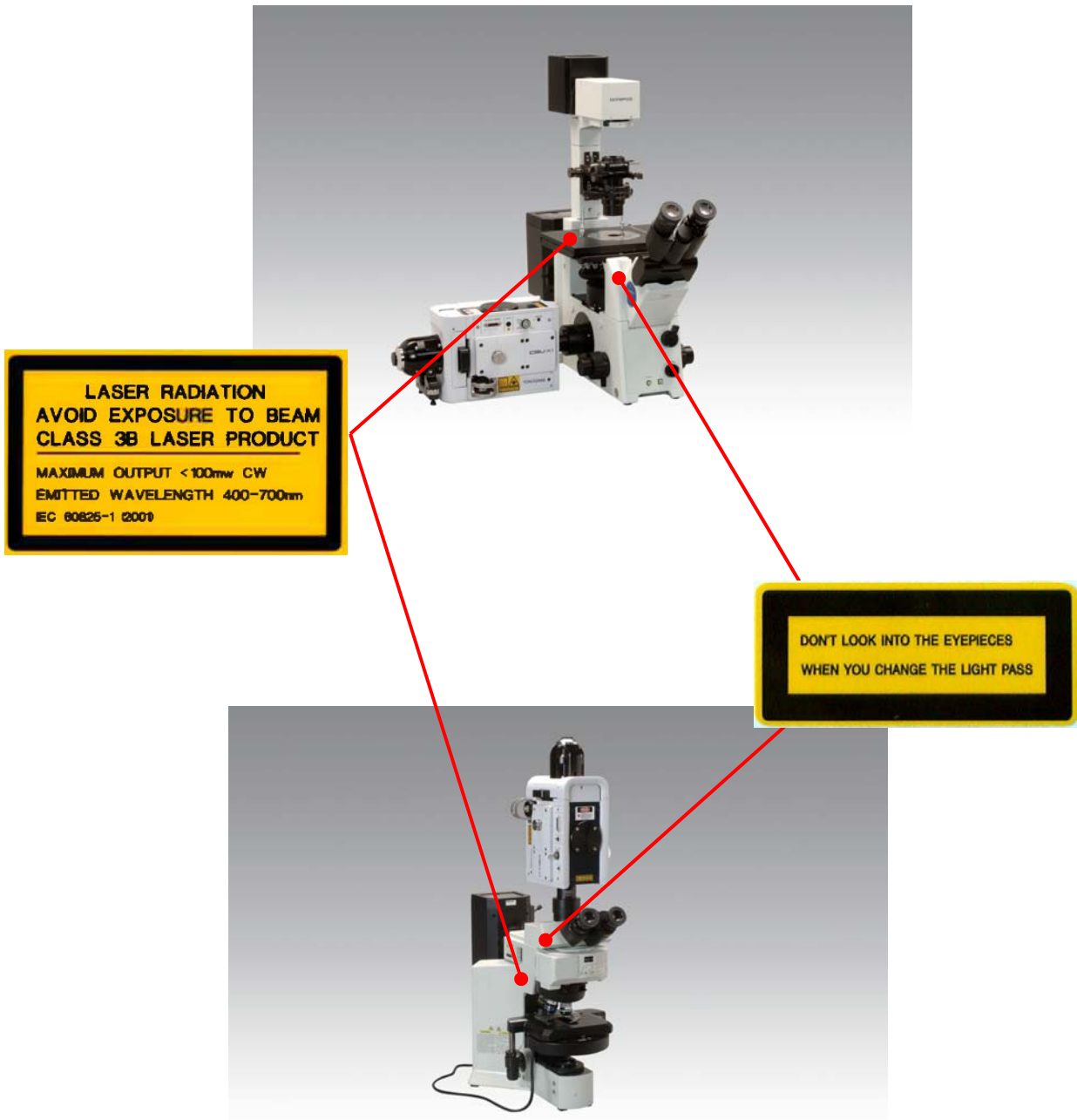

Figure 1-7 Examples of warning labels attached to the microscope

## 2 Product Overview

### 2.1 Principle of the Confocal Microscope

As conventional optical microscopes use surface light sources such as halogen lamp or others, diffused light from places other than the point of interest are mixed with the light from the point of interest. Further, when planar photo detectors like cameras or eyes are used, blurred, out-of-focus light from the points shifted toward the optical axis are observed, overlapped with the observed light. For these reasons, the conventional optical microscope has a limited spatial resolution. On the contrary, confocal microscope systems use laser beams to illuminate samples with pin-point accuracy, to eliminate diffused light from sources other than the point of interest. In addition, pin-hole windows are provided in front of the light detector to cut off the light from sources other than the point of interest for high resolution.

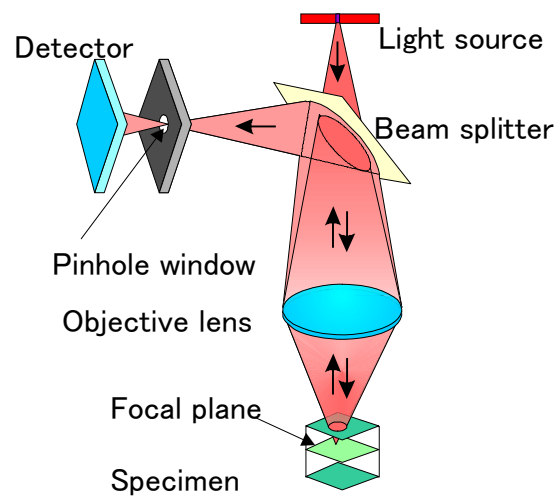

Figure 2-1 Principle of the confocal microscope

## 2.2 Structure and Features of the CSU-X1

The CSU-X1 has a combination of upper and lower disks rotated by a motor. As shown in Figure 2-2, about 20,000 microlens in the upper disk focus collimated light from a laser on corresponding pinholes in the lower disk, which are arranged in the same pattern as the microlens on the upper disk. The light passing through the pinhole is focused by an objective lens on the specimen. Light from the specimen returns along the same path through the objective lens and pinholes, is reflected by a dichroic mirror, and is focused at a camera or eyepiece. The upper disk containing the microlens is mechanically connected to the lower disk containing the pinholes, and a motor rotates the both disks. Thus, the light beams can illuminate the entire observation area of the specimen and forms a confocal optical slice at the camera or eyepiece.

The CSU-X1 has a built-in microcomputer. It is possible to control various operations by communication with an external computer (optional).

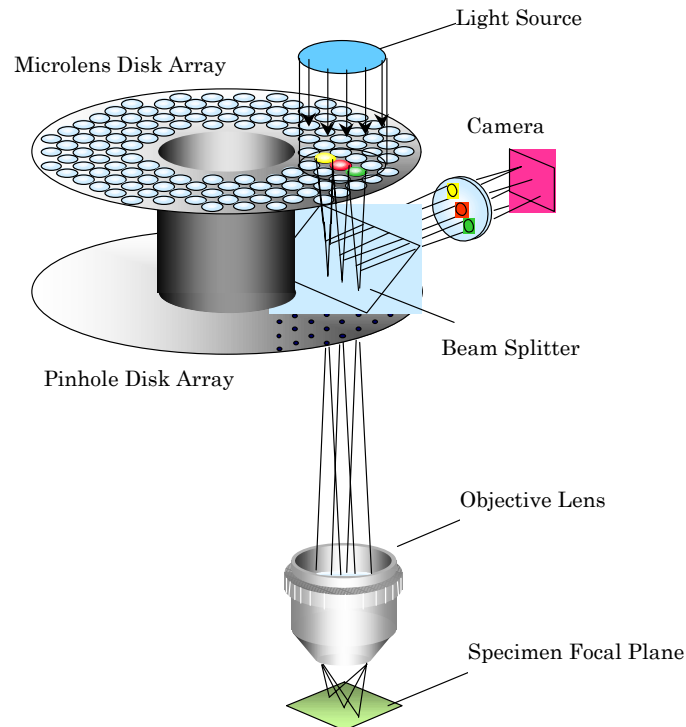

Figure 2-2 Basic configuration of the CSU-X1

## 2.3 Description of CSU-X1

CSU-X1 was developed as an advanced model of our conventional CSU10/22 models which have been widely used as a standard tool for live cell imaging.

As enlisted below, CSU-X1 is significantly improved in its basic optical features. Moreover, various optional systems are available to allow flexible design of total imaging system as you need.

- a. Newly developed lens system allows about twice highly efficient excitation power. (\*1)
- b. High speed shutter to work minimizing laser damage/photo bleaching.
- c. Doubled the maximum scanning speed from 1,000fps (CSU22) to 2000fps.(High-speed model)
- d. Bright Field Switching port (CSU-X1-A2, -M2) is an emission light path to bypass the disks in the CSU-X1, and allows you to use the same camera for both confocal and non-confocal (\*2) imaging without light loss.
- e. Second camera port (CSU-X1-A3) is for either to install a second camera or direct view ocular port. (\*3) By using an appropriate dichroic mirror, simultaneous two color imaging with two cameras is possible.
- f. User can manually exchange the dichroic mirror blocks in the CSU-X1.
- g. High-end models (CSU-X1-A1, -A2, -A3) provide controllable dichroic mirror block for up to three dichroic mirrors.
- h. Basic model provides a dichroic mirror block for one dichroic mirror.
- i. High-end models (CSU-X1-A1, -A2, -A3) provide function to control Yokogawa high-speed filter wheel.
- j. Direct C-mount adapter for 8X8 mm CCD camera such as EMCCD camera is available.

(\*1) Actual light efficiency depends on the total system including the microscope optics.

(\*2) Bright Field means non-confocal, wide-field images such as DIC, phase, epifluorescence and TIRF.

(\*3) It is necessary to use appropriate barrier filter for laser safety.

### 2.3.1 CSU-X1-M1

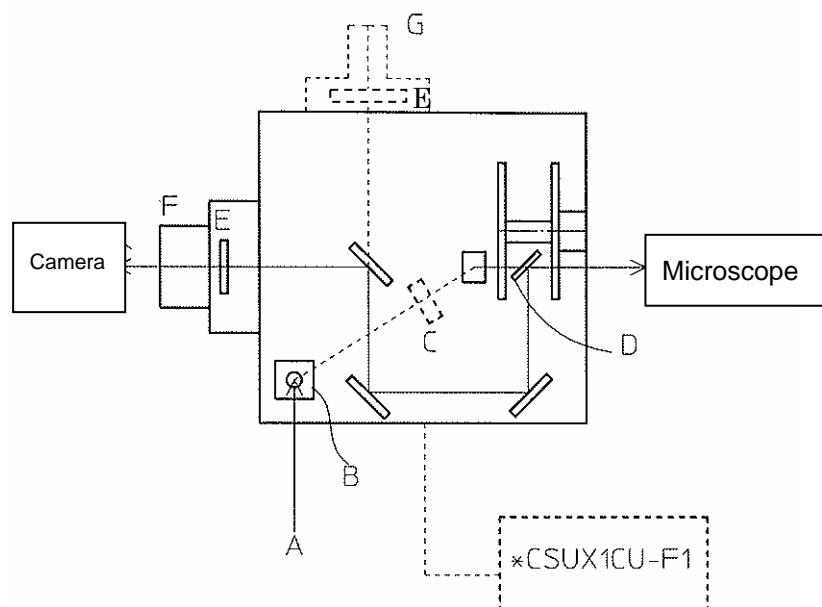

\*Control unit: CSU-X1CF-F1 is ONLY connectable with CSU-X1-M1H or M1N

- A: Laser inlet
- B: FC connector/shutter
- C: Excitation filter (See Option List)
- D: Dichroic mirror (See Specification List)
- E: Barrier filter (See Specification List)
- F: Camera port
- \*8X8mm adapter for EMCCD is available. (Option)
- G: Direct view eyepiece unit (Option)

CSU-X1-M1 is a Basic model.

Your choice of one dichroic mirror and one barrier filter can be installed at your order. Options shown above are selectable.

Maximum disk rotation speed for CSU-X1-M1L is 1,800rpm. If connected with the control unit CSU-X1CU-F1, rotation speed of CSU-X1-M1H is adjustable between 1,500 ~ 10,000rpm and that of CSU-X1-M1N is between 1,500 ~ 5,000rpm, respectively.

### 2.3.2 CSU-X1-M2

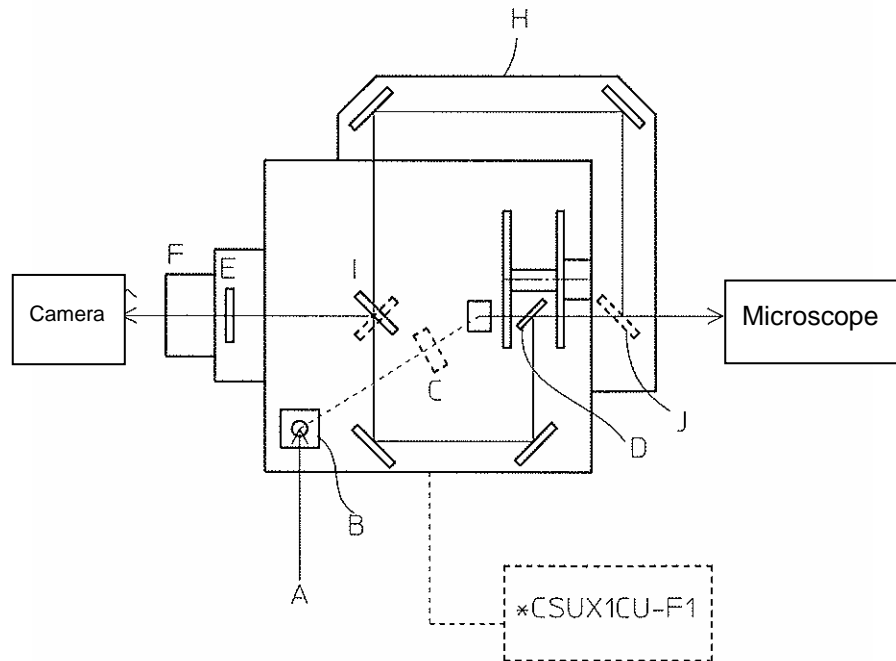

\*Control unit, CSU-X1CF-F1 is ONLY connectable with CSU-X1-M1H, M1N

- A: Laser inlet
- B: FC connector/shutter
- C: Excitation filter (Option)
- D: Dichroic mirror (See Specification List)
- E: Barrier filter (See Specification List)
- F: Camera port
- \*8X8mm adapter for EMCCD is available. (Option)
- G: Direct view eyepiece unit (Option)
- H: Bright Field Unit
- I: Manual Light Path Switching port
- J: Manual Light Path Switching port

This model is CSU-X1-M1 plus Bright Field port, which is an emission light path to bypass the disks in the CSU-X1, and allows you to use the same camera for both confocal and non-confocal (\*1) imaging without light loss. Light path can be switched manually by moving the two ports (I & J).

- Bright Field means non-confocal, wide-field images such as DLC, phase, epifluorescence and TIRF.



### 2.3.3 CSU-X1-A1

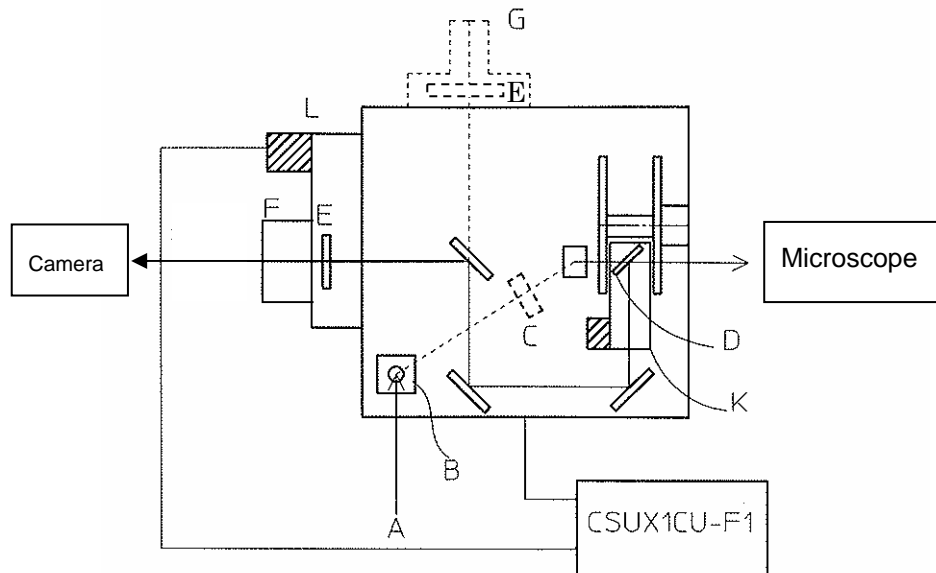

A: Laser inlet

B: FC connector/shutter

C: Excitation filter (Option)

D: Dichroic mirror (See Specification List)

E: Barrier filter (See Specification List)

F: Camera port

\*8X8mm adapter for EMCCD is available. (Option)

G: Direct view eyepiece unit (Option)

K: Dichroic mirror block (automatic control for up to three dichroic mirrors)

L: Filter Wheel (for up to six barrier filters)

This is a High-end model with motorized dichroic mirror unit for up to 3 dichroic mirrors and a filter wheel for up to 6 filters.

Disk rotation speed is adjustable between 1,500~10,000rpm (CSU-X1-A1H ) or between 1,500 ~ 5,000rpm(CSU-X1-A1N), respectively, if connected with the control unit, CSU-X1CU-F1.

## 2.3.4 CSU-X1-A2

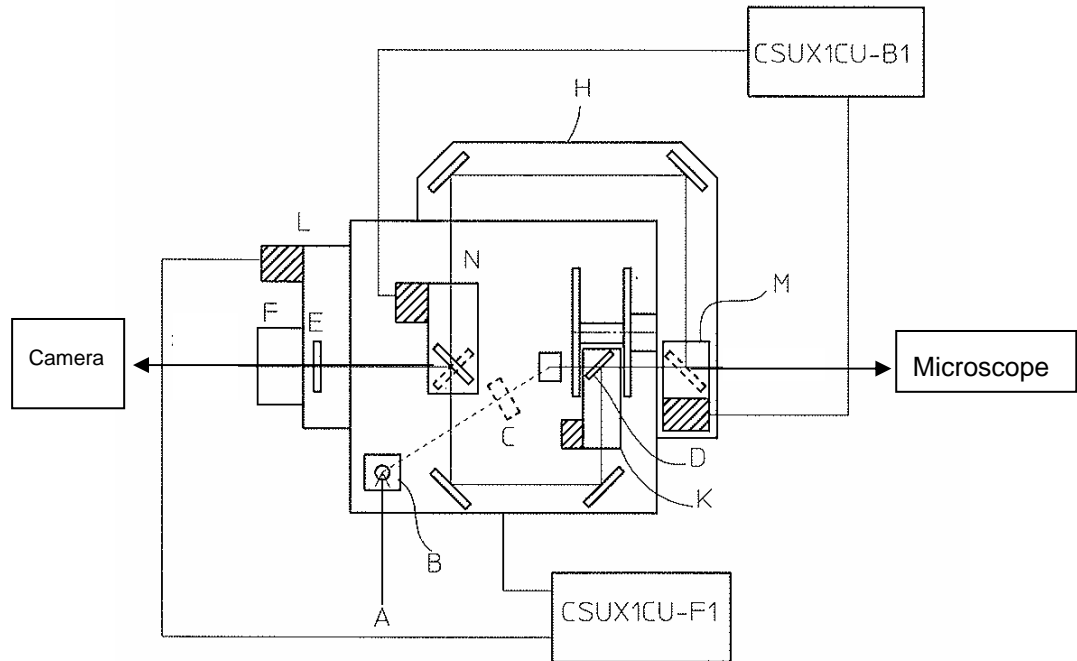

A: Laser inlet

B: FC connector/shutter

C: Excitation filter (Option)

D: Dichroic mirror (See Specification List)

E: Barrier filter (See Specification List)

F: Camera port

\*8X8mm adapter for EMCCD is available. (Option)

H: Direct view eyepiece unit (Option)

K: Dichroic mirror block (automatic control, for up to three dichroic mirrors)

L: Filter Wheel (for up to six barrier filters)

M: Motorized light path switching port 1

N: Motorized light path switching port 2

This model is CSU-X1-A1 plus Bright Field port, which is an emission light path to bypass the disks in the CSU-X1, and allows you to use the same camera for both confocal and non-confocal imaging without light loss. Light path switching is controlled by the control unit: CSU-X1CU-F1

Bright Field means non-confocal, wide-field images such as DLC, phase, epifluorescence and TIRF.

### 2.3.5 CSU-X1-A3

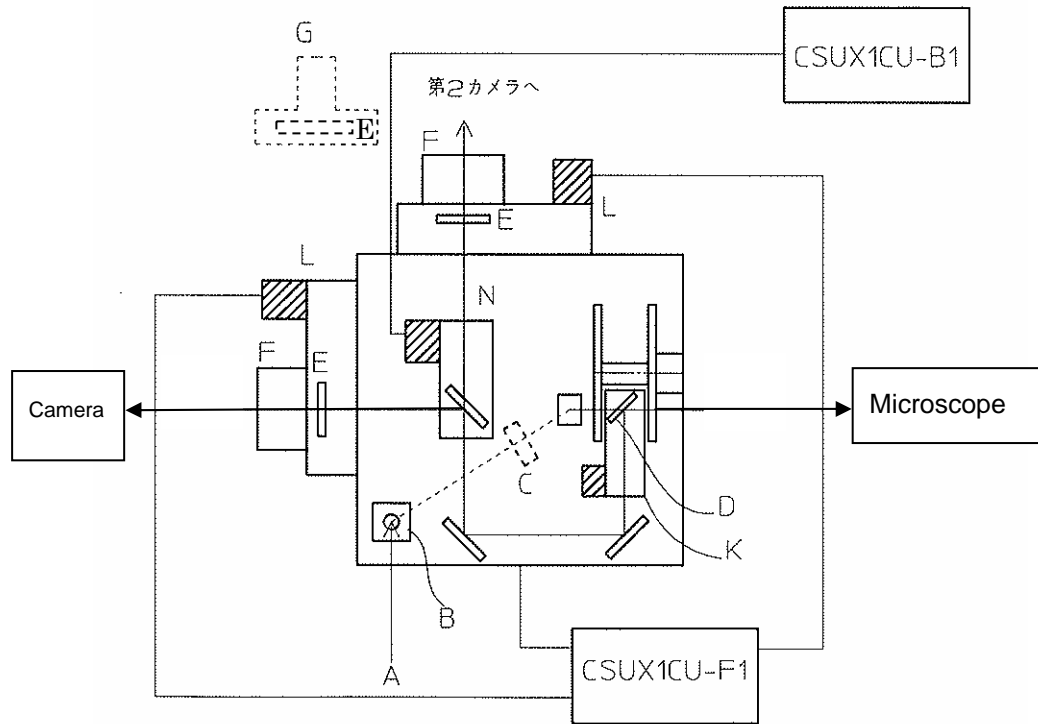

- A: Laser inlet
- B: FC connector/shutter
- C: Excitation filter (Option)
- D: Dichroic mirror (See Specification List)
- E: Barrier filter (See Specification List)
- F: Camera port
- \*8X8mm adapter for EMCCD is available. (Option)
- H: Bright Field Unit
- K: Dichroic mirror block (automatic control, for up to three dichroic mirrors)
- L: Filter Wheel (for up to six barrier filters)
- N: Automatic Light Path Switching port

This model is CSU-X1-A1 plus 2<sup>nd</sup> camera port to enable installation of two cameras. Light path switching between two camera ports is controlled by the control unit: CSU-X1CU-F1. Dichroic mirror for simultaneous imaging with two cameras can be installed. It is also possible to install confocal ocular port instead of the second camera.

## 3 Before Using the Unit

### 3.1 Packing List

Part name	Part number	QTY	Description
CSU-X1	CSU-X1	1	
AC adapter	M3916UD	1	Power supply for CSU-X1
Power cable	A1077WD	1	AC adapter cable
Warning label	D8953RH	1	「Don't look into the eyepieces when you change the light pass.」
Warning label	M3916LK	1	「LASER RADIATION AVOID EXPOSURE TO BEAM CLASS 3B LASER PRODUCT」
Interlock key for CSU-X1 unit	M3916HA	1	To control CSU-X1 from the control panel
Allen wrench	M3916CV	1	For M3 set screw to fix a camera to C-mount
Bottom port cover	D8953GV	1	For laser output hole, mounted at factory.
Second port cover	M3916CN	1	For second camera port, mounted at factory. (Bright Field or two FW type)
Second port cover screws		4	Could be mounted at factory
Camera port *1	M3916JA	1	Camera port of CSU-X1.
Camera port support	M3916CT	1	Support when CSU-X1 is installed at side port of inverted microscope.
Screw	Y9510ZU	2	To fix M3916CT camera port support
Key Switch		1	Spare key
Optical Fiber	M3916VU	1	Angled 8 degrees polished, AFC connector



#### CAUTION

Please only use CSU-X1 specific optical fiber supplied with the CSU-X1 head for the best optical performance. In case different optical fibers were used, CSU-X1 may not be able to work at its best optical performance.

## 3.2 Option List

### 3.2.1 Filter wheel control unit (CSU-X1CU-F1)

Part name	Part number	QTY	Description
Filter wheel control unit	M3918EA	1	Main control unit
Interlock cable	M3918AN	1	2.5m shield cable for control unit
Communication cable	M3918WA	1	Crossing serial cable, DSUB 9-pin, female-female, 3m shield cable
Controller Interlock key	M3918AT	1	Interlock key for control unit

### 3.2.2 Filter wheel (CSU-X1FW):

Necessary for CSU-X1-A1, -A2, -A3, -M1N, -M1H, -M2N, -M2H

Part name	Part number	QTY	Description
Filter wheel	M3918MA	1	Filter wheel unit
Aluminum disc	M3916MW	6	Aluminum disc to fill open positions in the filter wheel for weight balance
Connection cable 1 *1	M3918AP	1	2.5m shield cable for filter wheel 1,
Connection cable 2 *1	M3918AQ	1	2.5m shield cable for filter wheel 2
Filter Wrench	M3916CX	1	Tool for exchanging filters in the filter wheel

\*1: Connection cable 1 is supplied with CSU-X1FW-06P-01, and Connection cable 2 is supplied with CSU-X1FW-06P-02

### 3.2.3 Bright Field Control unit (CSU-X1CU-B1)

Necessary for CSU-X1-A2, -A3

Part name	Part number	QTY	Description
Bright Field control unit	M3918EB	1	Main unit
Connection cable 1	M3918AR	1	2.5m shield cable for Bright Field 1,
Connection cable 2	M3918AS	1	2.5m shield cable for Bright Field 2,
Interlock cable	M3918AN	1	2.5m shield cable for Control unit Interlock
Communication cable *1	M3918WA	1	Crossing serial cable, DSUB 9-pin, female-female, 3m shield cable
Controller Interlock key	M3918AT	1	Interlock key for control unit

\*1: Not supplied if you already have filter wheel control unit (CSU-X1CU-F1) .



## CAUTION

Please ONLY use supplied cables, otherwise, it is possible to fail EMC conformity.

## 3.3 Installation

For installation, please follow instructions and installation manual of the microscope, laser system, fiber coupler, camera, etc.



### CAUTION

Do not use a different microscope or laser system from the originally installed system.

If you need to use a microscope or laser system different from the originally installed one, please consult Yokogawa Electric Corporation or your local sales representative. Please strictly follow Class 3B laser safety instructions in manipulating the optical fiber and optical fiber coupler when you connect to, adjust, or remove from the laser system or the CSU-X1.

### 3.3.1 Installation of Microscope

Please follow the instructions given in the user's manual of the microscope manufacturer.

For confocal imaging, laser beam emerges from the objective lens to excite fluorescence of the specimen when CSU-X1 is set to the microscope to output a laser beam and the microscope's light path is set for confocal observation. Part of the laser beam may be reflected at the specimen's surface, and a reflected laser beam may be observed. Be careful not to look at the reflected laser beam from the specimen's surface, or shield the stage so that it does not go directly into your eyes.

The reflected laser beam goes through the objective lens, and depending on your light path setting, it may be observed from the eyepiece of the microscope. As the reflected laser beam may come out from the ocular lens of the microscope, you must perform the inspection and modification described in Items (1) and (2) on the next page, and operate the microscope and unit by following the guidelines given below.

In confocal observation, the light observed through the eyepiece of CSU-X1 (Option) is weak fluorescence from the specimen. The unit is designed in a way that no reflected laser beam should be observed via the eyepiece if proper barrier filter is installed.

However when the system is under automatic control, there is a possibility of leakage of laser beam into the eyepiece, which is extremely hazardous. If you control the filters from the computer commands, **DO NOT LOOK INTO THE EYEPIECE!**

NOTE: When incident laser power (488 nm) is 30mW at the end of the fiber, incident laser power at the objective lens is about 3mW(typical). Assuming the multiple reflection rate of the cover glass to be 8%, the reflected laser beam could be around 0.24mW, which corresponds to Class II (\*) of JIS laser safety standard (488nm, 1mW

or less at CW)

\* Brief summary of laser safety standard:

Class 1: Intrinsically safe, having little possibility of damaging eyes if looked at for some time.

Class 2: Little possibility of damaging eyes if the exposure time is less than 0.25 seconds.

Class 3B: Hazardous to eyes if the laser beam is looked at directly. Even if you use a laser beam weaker than this class, damage to the eyes may occur.

 CAUTION

Please refer to laser safety manual to fully understand laser safety requirement.

 CAUTION

(1) Inspection of tripod of the microscope

Laser beam reflected at the surface of specimen/cover glass could possibly return the light path, emerge at the microscope eyepiece, and be directed into your eyes. To prevent a hazardous accident, please inspect your microscope and take the necessary measures in accordance with the following directions:

Please only use 0-100/100-0% switch to select the light path between camera port and eyepiece port of the microscope.

Before installing the CSU-X1 to the microscope, please inspect the microscope. If there are reflective surfaces inside the microscope due to reasons such as damage to inner painted areas in the microscope or damaged prism masking, laser beam could be reflected and directed into the microscope eyepiece. Please repair any damage inside the microscope before installing the scanner unit.

## (2) Modification of non 100/0 microscope

Some microscopes, typically Olympus BX50 series, have a slider (switching between eyepiece and camera port) other than 100/0 or 0/100, such as 20/80. If the switching slider was set at a non-100/0 position, part of the reflected laser beam will reach into the microscope eyepiece. Never use such non-100/0 position for your own safety. It is highly recommended to seal such non-100/0 slider windows with black tape so as to prevent accidental laser exposure. Figure 3-2 shows examples of where to seal the 20/80 windows of the switching slide of the Olympus BX50 microscope. Please make sure both windows (eyepiece side and camera port side) are sealed. Furthermore, it is strongly recommended that you should always shut CSU-X1 shutter when you are not observing confocal images, so that you can avoid accidental laser exposure.

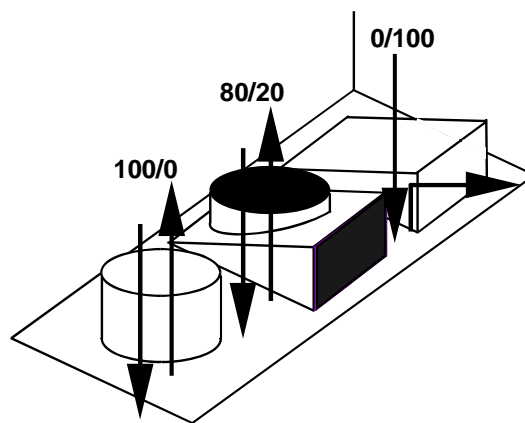

Figure 3-2 Where to seal the 20/80 windows of the switching slider of the Olympus BX50 microscope

When you switch the light path between confocal and non-confocal observation, (epifluorescence, transmitted light image, etc.) reflected laser beam could reach into the microscope eyepiece at the moment of switching due to the reflection at the edge of switching prism.

Never look into the microscope eyepiece when you change the light path, and always shut the CSU-X1 shutter when you switch the light path, or turn off the laser when you switch the light path.

## (3) Laser warning labels

Please attach laser warning labels on your microscope as indicated in Figure 1-3.



### 3.3.2 Installation of Laser System and Adjustment of Fiber Coupler

Please follow the instructions given in each of the user's manuals to install the laser system and fiber coupler, and make adjustments so that the connection between the laser source and fiber coupler can be optimized.



#### WARNING

You should strictly follow the laser hazard class 3B safety requirements whenever you install, adjust, or remove the fiber coupler from the laser system, and connect or disconnect the fiber from the CSU-X1.

Never touch the tip of the fiber and be most careful to keep the fiber tip clean. If you touch or damage the tip, the laser output power at the fiber will be affected, and thus the confocal image will be impaired. When you measure the laser output power at the fiber tip, please set the laser power at the minimum level. Possibility of damage to the fiber due to air dust would be higher if the output is set higher, and the laser beam might be diffused.

To prevent damages on the system, please use the laser of less than 100mW. Use of higher than 100mW laser may damage the CSU-X1 system.

Use of control, adjustment or performance of procedures other than those specified herein may result in hazardous radiation exposure. Never use lasers outside of the specification.

#### NOTE :

Recommended laser specification:

Range of wavelength: 405nm to 647nm.

Laser power: 100mW or less at either input to the CSU-X1 or fiber output.

#### NOTE :

The best efficiency of laser coupling by the coupler is 50% or more. To examine laser outputs from your laser system and the fiber, it is recommended to use a power meter for measurement.

### 3.3.3 Installation of CSU-X1



#### CAUTION

Do not turn on the laser system before all the installation and connection procedures described below have been completed.

#### (1) Mechanical and optical installation and connection

Attach the microscope C-mount adapter to the bottom of the CSU-X1 by turning clockwise until hand-tight in accordance with the microscope user's manual. Be careful not to thread too tight.

When you set the CSU-X1 to side port of an invert type microscope, please support the CSU-X1 with the level screw provided so that the adapter will not be deformed. Depending of the microscope type, it may be necessary to insert appropriate spacers under the microscope.

#### (2) Electrical connection

Plug the DC plug of the AC adapter into the DC POWER of the CSU-X1. You must always use the AC adapter supplied with CSU-X1.

For laser safety, the scanner power switch is designed as a key switch. To turn the unit on, insert the key provided.

#### (3) Connection of fiber

Connect the fiber to the FC connector port of the CSU-X1 by matching the guide key on the FC connector and fiber connector and turning the screw tightly. Attach fiber guard.



#### CAUTION

Please only use CSU-X1 specific optical fiber supplied with the CSU-X1 head for the best optical performance. In case different optical fibers were used, CSU-X1 may not be able to work at its best optical performance.

#### (4) Interlock

If you use the optional control unit, please refer (5) and (6).

Before use, insert CSU-X1 interlock key supplied with the unit into the interlock connector and then turn the power switch on. The interlock is unlocked, enabling you to manually open/close the shutter from the operation panel.

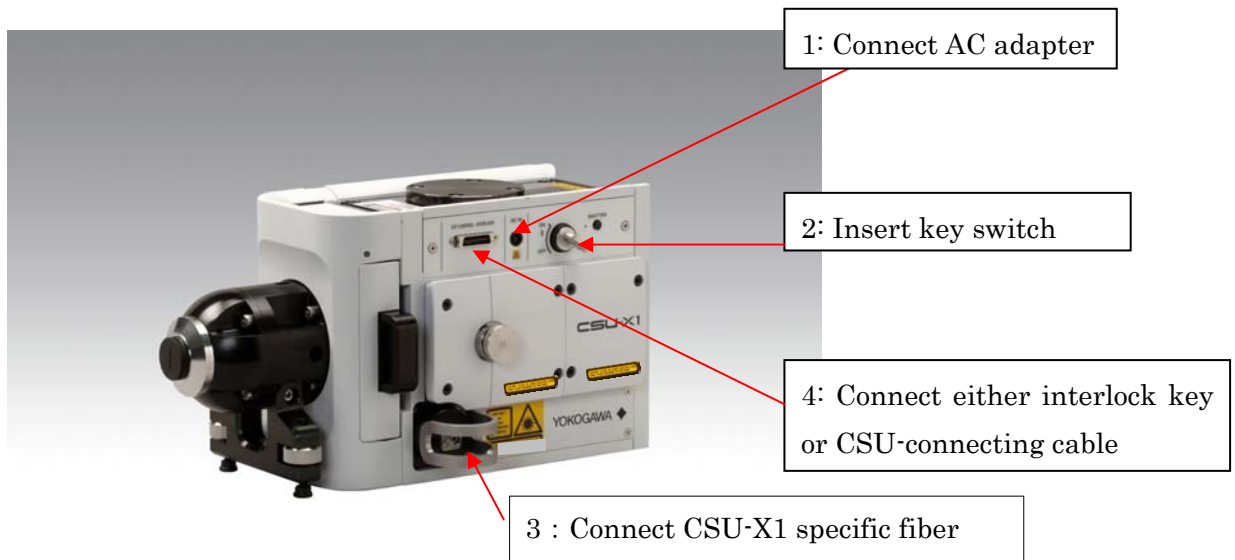

The photo shows the CSU-X1-M1 model, but the same for M2, A1, A2 and A3 models..

(5) Connection with control unit: CSU-X1CU-F1

- a. Connect the CSU connector of control unit (CSU-X1CU-F1) and the EXT CONTROL / INTERLOCK connector of CSU-X1 with supplied cable.
- b. Insert controller interlock key to EXT CONTROL / INTERLOCK
- c. Connect RS232C1 connector of the control unit and a PC with RS232C cable.
- d. Connect MOTOR1 connector and Filter Wheel 1.with supplied FW1 cable.
- e. Connect MOTOR2 connector and Filter Wheel 2 with supplied FW2 cable, if necessary.
- f. Connect power cable after confirming the power switch is OFF.

Please use power receptacle with the following specification:

3-prong plug with protective earth terminal.

Rated supply voltage: 100-240VAC,

Voltage frequency range: 90-264VAC.

Rated supply frequency: 50-60Hz.,

Supply frequency tolerance: 48-63Hz.,

Max. power consumption:200VA

 **WARNING**

- Please confirm your power supply is suitable for the rated supply voltage of the CSU-X1 before connection.

- Please confirm all main switches of CSU-X1 and attached instruments are OFF before connecting power cord.
- Please only use provided power cord to avoid any risks such as fire or electrification
- Please always use 3-prong plug with protective earth terminal to avoid risk of electrification.

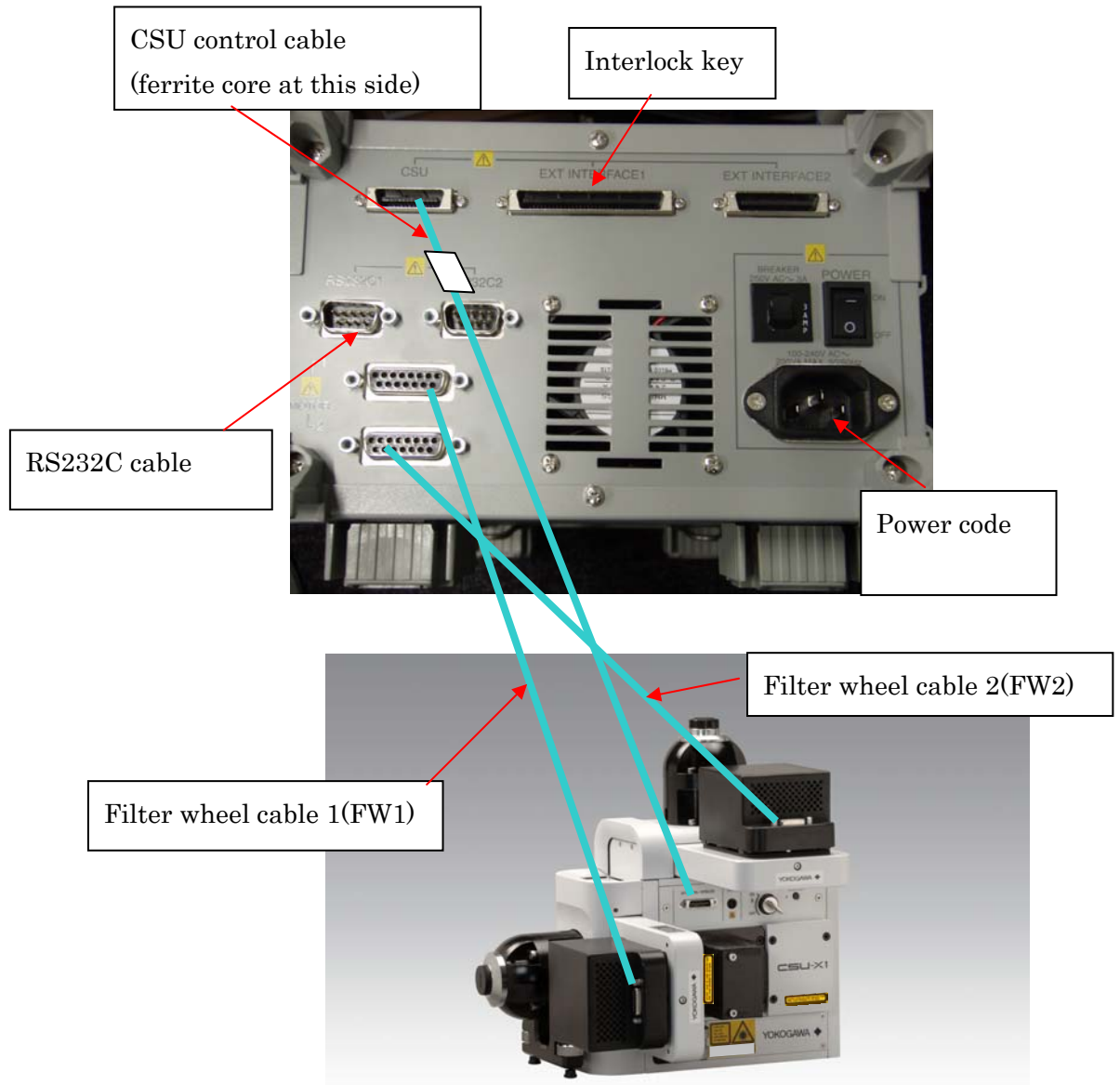

## CAUTION

Please ONLY use supplied cables, otherwise, it is possible to fail EMC conformity.

(6) Connection with control unit: CSU-X1CU-B1

To use CSU-X1-A2 or A3, you have to connect Bright Field control unit: CSU-X1CU-B1 to CSU-X1.

- a. Connect RS232C2 connector of CSU-X1CU-F1 to RS232C1 connector of the second control unit: CSU-X1CU-B1 with supplied cable.
- b. Insert interlock key into EXT INTERFACE1/L.LOCK
- c. Connect MOTOR1 of the second control unit: CSU-X1CU-B1 with BF1 connector of CSU-X1 using BF1 cable, and MOTOR 1 with BF2 connector using BF2 cable, respectively.
- d. In the case of CSU-X1-A3, only connect MOTOR1 and BF1 connector of CSU-X1.
- e. Connect power cable after confirming the power switch is OFF.

Please use power receptacle with the following specification:

3-prong plug with protective earth terminal.

Rated supply voltage: 100-240VAC,

Voltage frequency range: 90-264VAC.

Rated supply frequency: 50-60Hz.,

Supply frequency tolerance: 48-63Hz.,

Max. power consumption:200VA



## WARNING

- Please confirm your power supply is suitable for the rated supply voltage of the CSU-X1 before connection.
- Please confirm all main switches of CSU-X1 and attached instruments are OFF before connecting power cord.
- Please only use provided power cord to avoid any risks such as fire or electrification
- Please always use 3-prong plug with protective earth terminal to avoid risk of electrification.

RS232C cable: connect with RS232C2 of control unit (CSU-X1CU-F1)

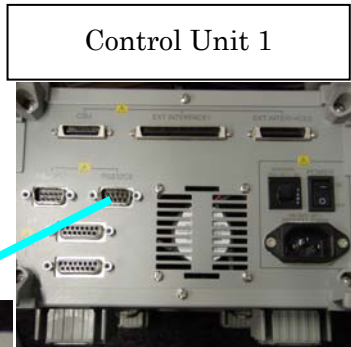

Power code

Bright Field2 (BF2) cable

Bright Field1 (BF1) cable



### CAUTION

Please ONLY use supplied cables, otherwise, it is possible to fail EMC conformity.

### 3.3.4 Connection Diagram

CSU-X1-A1

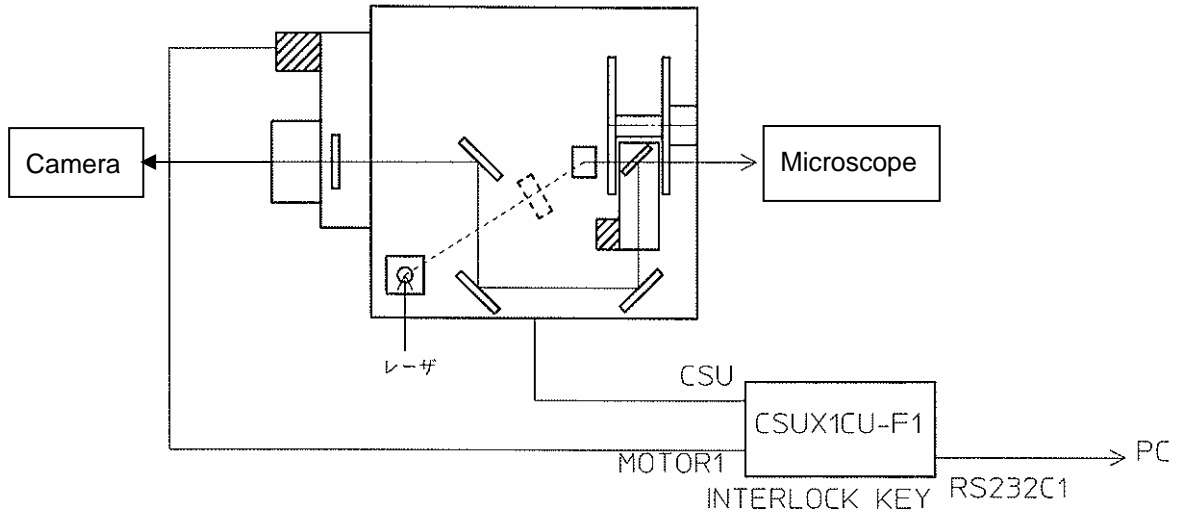

CSU-X1-A2

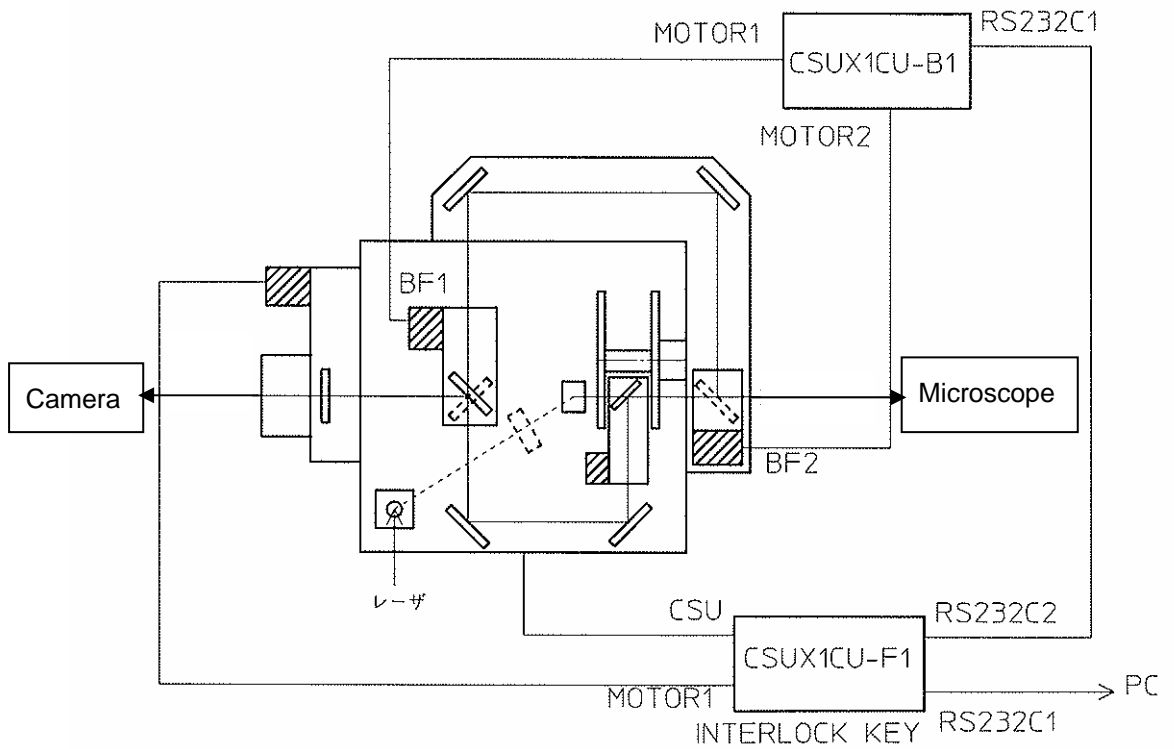

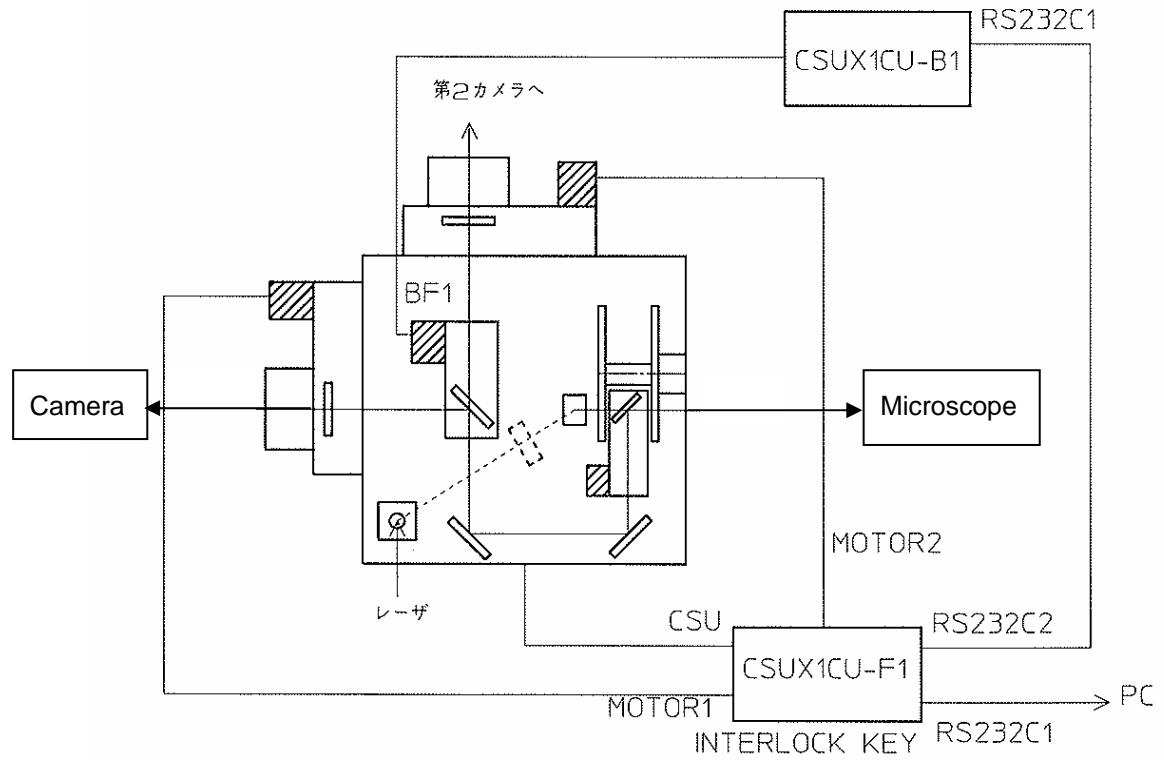

**CAUTION**

You have to use supplied cables ONLY, otherwise, it is possible to fail EMC conformity.



### 3.3.5 Installation of Camera

Please follow the user's manual of your camera when you mount it on the CSU-X1 using the C-mount adapter. Insert the C-mount adapter fixed to the camera into the camera port adapter on the unit. Use the M3 screws to fix the camera adapter with the Allen wrench provided.



#### CAUTION

The body of the CSU-X1 is durable up to 5 kg. If you install a camera heavier than 5 kg on the CSU-X1, please use an appropriate support to fix the camera so that the CSU-X1 will not be deformed.

When you install the CSU-X1 to the side port of an inverted microscope and mount a camera horizontally, please support the camera to prevent deformation of the camera adapter.

When you install the system onto an upright type microscope and total weight of confocal system including CSU-X1, its accessories including a camera surpassed microscope's maximum weight tolerance, it is necessary to support total system. Please inquire your local sales representative.

### 3.3.6 Power Switch

- Control Unit

Please confirm if the control unit Interlock key is inserted into EXT INTERFACE1/I.LOCK at the backside of the control unit. If not, please insert supplied key. Also, please confirm if CSU-X1 and the control unit is connected with supplied cable. And then, put the power of the control unit ON.

- CSU-X1

(1) Model without a control unit:

Please insert CSU-X1 Interlock key into EXT CONTROL / INTERLOCK connector before put ON the power. The interlock is unlocked, enabling you to manually open/close the shutter from the operation panel.

(2) Model with a control unit: CSU-X1CU-F1

Shutter control via panel switch or control unit becomes possible after CSU-X1 power is ON.



## WARNING

Never insert your fingers/hand into the holes in the filter wheel. If you do while the wheel is moving, you may injure your fingers/hand.



## CAUTION

Please refer to the specification sheet in this manual to learn the conditions of filter wheel moving speed. If you try to move too fast, the filter wheel could fail to move properly.

### 3.3.7 Power Off

#### (1) CSU-X1

Please close the shutter first either manually by shutter button, or by “shutter close” command when you use control unit, before shut down the CSU-X1 by turning the key switch to OFF position.



## WARNING

- If you shut down the CSU-X1 when shutter is open, shutter may not be completely closed. In such case, please switch on again so that the system returns to default status and shutter closes.

#### (2) Control Unit

Please switch off the power switch at the back panel of the control unit.

## 4 Name and Function

### 4.1 M1 Model

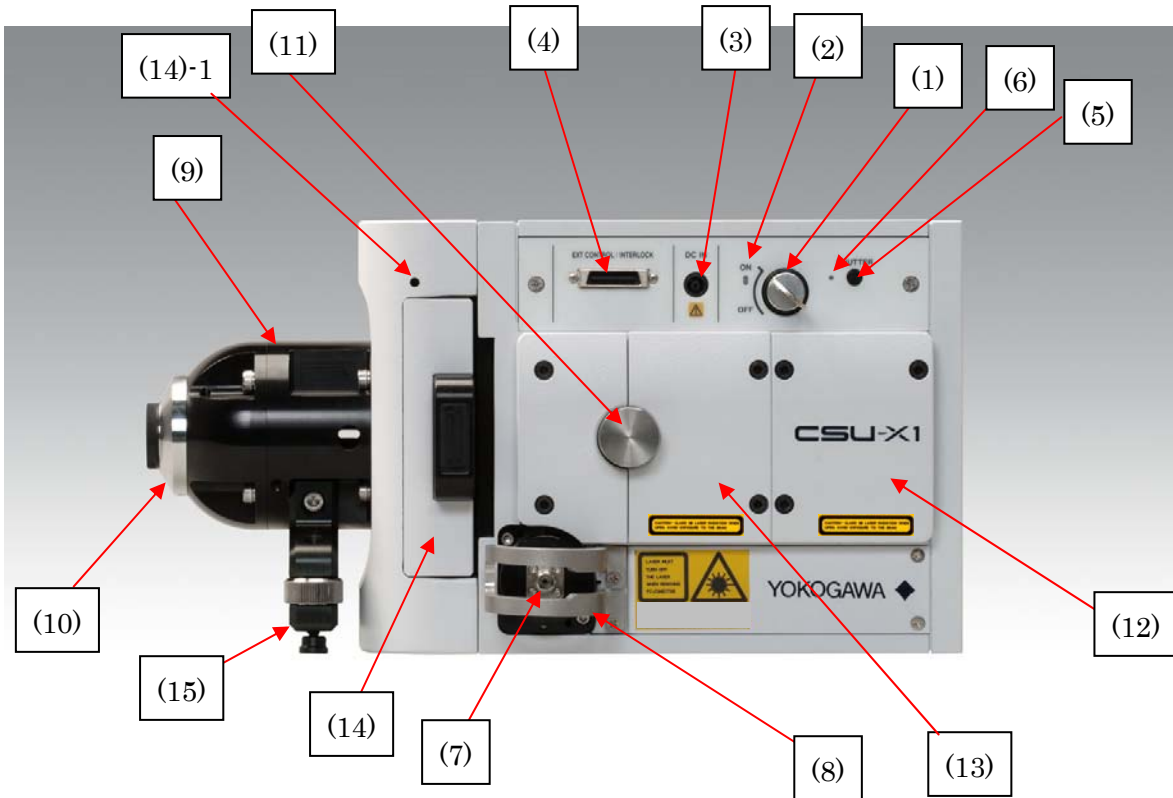

(1) Key switch

Turn from OFF to ON position when use at user initialized status (explained later). If you wish to re-set the CSU-X1, turn the key to OFF position and ON again. You cannot remove the key switch at ON position.

(2) Power ON indicator

Green LED lights when power is ON. LED is off when power is OFF.

(3) Power port

DC POWER input port.

(4) Interlock key port

Insert supplied CSU-X1 interlock key here for manual shutter control. Remote shutter control is enabled by connecting with a control unit with interlock cable (option). For urgent system shut down, it is possible to shut off laser beam and stop disk motor by disconnecting the interlock key.

(5) Shutter button

Momentary switch to open/close shutter.

(6) Shutter light

Red LED lights when shutter is open, no light when closed.

(7) FC connector

FC connector of the fiber is connected here. Please firmly connect the fiber by adjusting to the guide key and tightly screw. Please use supplied FC connector cover for a dust cover in case of storing or fiber exchange.

(8) Fiber guard

Guard to protect fiber from mechanical damage.

(9) C-mount

Camera port. Please use supplied C-mount adapter (D8953CF) to set a camera on this port, and fix with set screws.

(10) C-mount adapter(D8953CF)

(11) Port switching knob (manual)

Knob to switch light path between 1<sup>st</sup> camera port (pushed) and 2<sup>nd</sup> camera port (pulled). In the case of A2 and A3 models, no manual knob is provided since they have motorized switching system.

(12) Dichroic mirror block cover

This cover will be removed when to set or exchange the dichroic mirror block inside. If you open this cover, Class 3B laser beam could be emitted. Warning sign to class 3B laser radiation to advise to avoid exposure to the beam is attached. Please ask for the advice from your support service when you wish to exchange the DM block.

(13) Light path selecting block cover

Light path selecting block to set either a dichroic mirror or reflection mirror inside. If you open this cover, Class 3B laser beam could be emitted. Warning sign for class 3B laser radiation to ask avoiding exposure to the beam is attached.. Please ask for the advice from your support service when you wish to exchange the mirrors.

(14) BA (Barrier) filter block

Barrier filter block will be set here. When you remove this block for filter exchange, please turn off the power for laser safety.

(14)-1 Fixing screw for setting the BA filter block or filter wheel unit

(15) Camera port support

To adjust height and support weight when CSU-X1 is installed at the side port of microscope.



(16)

(16) C-mount port

The port to connect C-mount adapter of your microscope. Dust cover (D8953GV) is fixed at factory.

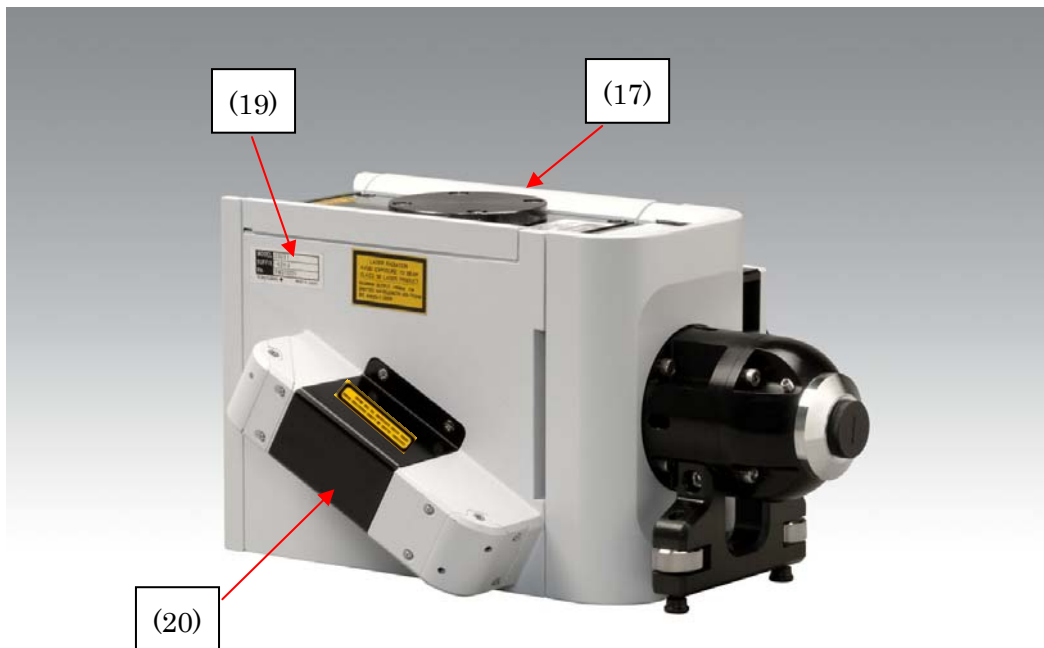

(17) Dust cover for 2<sup>nd</sup> camera port will be provided with M1 and A1 models.

(18) Space for excitation filter block.

The same excitation block with that of CSU10 can be inserted here.

(19) Identification label

MS code, rated supply voltage, product number and serial number

(20) Cover for the excitation light path

This cover may be removed when you install the excitation filter unit.

If you open this cover, Class 3B laser beam could be emitted. Warning sign to class 3B laser radiation to ask avoiding exposure to the beam is attached. Please ask for the advice from your support service when you wish to install or exchange the excitation filter unit..

Please refer to Chapter 1 for the explanation of warning labels.

## 4.2 M2 Model

\*Please refer to 4.1 for common parts.



(21) Bright Field unit. Only for M2 and A2 models.

(22) Bright Field switching knob

Switch the light path between confocal (pushed) and bright field (non-confocal: pulled). In the case of A2 model, port switching is automated and no manual knob is provided.

(23) Microscope adapter

Microscope specific adapters are necessary to install Bright Field. (Option)

## 4.3 A1 Model



(24) Filter Wheel (1<sup>st</sup> camera port) Provided with A1, A2 and A3 models. Up to 6

emission filters can be installed.

#### 4.4 A2 Model



(25) Light path switching unit

Motorized unit for automated light path switching provided for A2 and A3 models.

#### 4.5 A3 Model



(26) Filter wheel for 2<sup>nd</sup> camera port

Provided with A3 model. Up to 6 emission filters can be installed.

(27) C-mount for 2<sup>nd</sup> camera port

To install a camera to the 2<sup>nd</sup> port with supplied adapter (D8953CF). Dust cover (D8953MZ) is fixed at factory. Please use dust cover when you don't use the 2<sup>nd</sup> port.

## 5 Maintenance

Never use organic solvent to clean the CSU-X1 body. Wipe off stains with clean cloths, and if necessary diluted detergent may be used to remove stubborn stains.

Always cover apertures of the CSU-X1(C-mount and camera port) with the provided dust covers when not in use.

Never open or touch the inside of the CSU-X1

Please consult Yokogawa Electric Corporation, or your local representative, in the case of malfunction.

### 5.1 BA Filter Exchange

#### (1) Basic model

1. Take out the BA filter block after loosening the fixing screw.
2. Take out BA filter after removing fixing screw ring by using supplied filter wrench
3. Insert and fix new BA filter with fixing screw ring by using the filter wrench  
(CAUTION: Do not touch and stain filter surface. Be careful to set the filter surface at the right direction.)
4. Fix filter block and tighten the fixing screw.

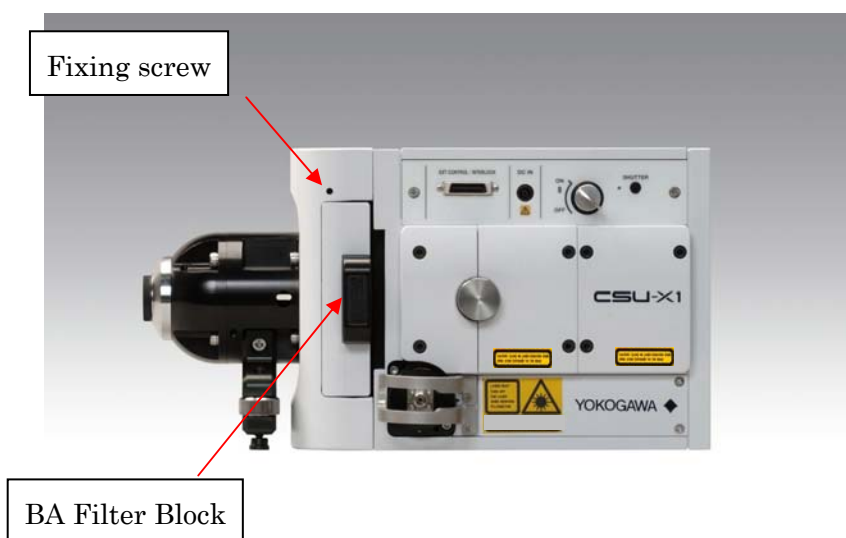

#### (2) High-end model

1. Take out filter wheel after removing the screw at the upper right side of filter block. (Please refer to the instruction manual of CSUX1FW for details.)
2. Remove cover, and take out BA filter after removing fixing screw ring by using supplied filter wrench
3. Insert and fix new BA filter with fixing screw ring by using the filter wrench



(**CAUTION:** Do not touch and stain filter surface! Be careful to set the filter surface at the right direction.)

4. Fix the cover



**Warning**



**CAUTION**

- Never inset your fingers in the open ports of filter wheel. You could injure fingers if the wheel moves.
- You must power-off the filter wheel when you exchange filter, otherwise you may injure fingers if the wheel moves by accident.
- Please fix supplied dummy filter disks at each of open position so as to balance weight. Without proper balance, filter wheel may not work properly.

## 5.2 Dichroic Mirror Unit Exchange

Please ask for the advice form your support service if you wish to exchange the DM unit.



**WARNING and PRECAUTION**

Never exchange the DM block when the laser beam is emitted.

The Class 3B laser radiation could be hazardous to the eyes if you directly look into the beam of reflected laser beam. You should avoid exposure to the beam.

## 6 Trouble Shooting

Please always follow safety instructions for laser hazard CLASS 3B products when you inspect CSU-X1 problems.

### 6.1 Microscope, Laser and fiber coupler

Please cope with any problems specific in the microscope, lasers, camera or fiber couplers by following instruction manuals of each instrument.

### 6.2 CSU-X1

	Problem	Possible Cause	Solution
a	No images confirmed when microscope light path is at the camera port	Light path switching knob is pulled	Push the knob and switch to 1 <sup>st</sup> port
		Motor not rotating	Turn on the key switch(Green LED)
		Too weak illumination of microscope	To increase illumination light power
b	No confocal images confirmed	No laser beam incident from the objective lens	Turn on key switch (Green LED). Switch microscope light path to camera port. Select through(no DM) block in the microscope Remove DIC polarizer Turn on the laser system
		Light path is at 2 <sup>nd</sup> port	Push the knob and switch to 1 <sup>st</sup> port
		Laser is too weak for proper excitation	Power up the laser
		Microscope illumination is ON	Turn down the illumination
		Camera is not working	Inspect the camera following its instruction manual
c	Visible dust	Dust at the specimen	Clean cover/slide glasses
		Objective lens is dirty	Clean the objective lens following microscope instruction
		Dust on the camera port, DM or pinhole disk surface.	Remove dusts with air-blow from the camera port aperture of CSU. Some dust could not be removable with air-blow. Some dusts could be hard to remove. But please be most careful to avoid damaging the optical parts. Small particles originating from the base plate of dichroic mirrors could be visualized with highly sensitive cameras as minor artifact images.

	Problem	Possible Cause	Solution
d	Shutter LED stay lighted against manual switch-off or command off	Shutter external control signal is at High	Set shutter external signal to Low, or stop signal input
e	Shutter LED blinks(Repeat blinking twice and off cycle)	Interlock is working	Connect interlock key if not Attach DM block cover properly
f	Shutter LED blinks(Repeat blinking 5 times and off cycle)	Total on/off cycle of shutter surpassed beyond guaranteed 60,000 times	Blinking stops by manual button. (Shutter works accordingly) Please call you local rep and exchange the shutter if this problem occurs

## 7 Specification

### 7.1 Product Specifications

#### 7.1.1 Specifications of CSU-X1 unit

Item	Specification
Principle	Dual Nipkow disk spinning scan with a microlens array
Scanning speed	1. Basic model * Standard 1: 1,800rpm (w/o control unit) * Standard 2: 1,500~5,000rpm (Max.1000fps, requires control unit) * High speed: 1,500~10,000rpm (Max.2000fps,requires control unit) 2. High-end model (with control unit) * Standard: 1,500~5,000rpm (Max.1,000fps) * High speed: 1,500~10,000rpm (Max. 2,000fps)
Scan area size	Standard: C mount: X 1, Image size 10×7mm<
Excitation laser range	405~647nm
Excitation laser power	50mW > after FC connector (Laser safety Class 3B)
EX (excitation) Filter	1. Standard: None 2. EX Filter Wheel (CSU-X1FW-06P-02) * Option: Please inquire (EX filter wheel is not directly attachable to the CSU-X1 body.) * EX filter line-up is shown in Table 7-1-1. 3. Manual exchange: * Option: 3 position slider is available, please inquire. * EX filter line-up is shown in the Tables 7-1-1-1, & -2.
DM (dichroic mirror)	1. Standard: None 2. Option: * Size: 13mm×15mm×0.5mm * DM line-up is shown in the Table 7-2-2.
DM exchange	1. Basic model (with & w/o control unit) * Only CH1 in the DM block is valid. * DM block can be exchanged manually(*) 2. High-end model (with control unit) * Three channels are available in a DM block * DM block can be exchanged manually(*)  <b>(CAUTION)</b> (*) Please ask the advice from your support service for safely exchanging the dichroic mirror block. Please comply with the laser Class 3B safety precautions.
Laser input	Yokogawa standard fiber supplied with the CSU-X1 head Connector 8 degrees polished, AFC connector
Shutter	1. Response time: 30msec (Not including communication and overhead of the firmware)

Item	Specification
	2. Life: on/off total count 60,000< 3. Continuous open/shut frequency: 3Hz>
Emission range	420~700nm
BA (barrier) filter	1. Standard: None 2. Option: BA line-up is shown in the Table 7-2-2 <b>(CAUTION)</b> You must install optimal BA filter to match the laser and DM.
BA filter position and exchange	1. Basic model One position in the filter slot at each of 1 <sup>st</sup> and 2 <sup>nd</sup> camera port. Filter size:φ25mm 2. High-end Model * To use Filter Wheels installed in the filter slot at each of 1 <sup>st</sup> and 2 <sup>nd</sup> camera port * CSU-X1FW-06P-01: Filter Wheel for 1 <sup>st</sup> camera port * CSU-X1FW-06P-02: Filter Wheel for 2 <sup>nd</sup> camera port * CSU-X1CU-F1 control unit is required to use CSU-X1FW-06P-01.
Bright Field (Non-confocal)/Confocal switching	1 Light path exchange (High-end mode): * Motor driven: Requires CSU-X1CU-B1(Bright Field control unit) 2 Light path exchange (Basic mode) * Manually exchange two ports with each lever
Microscope connection	1. Standard: C mount of each microscope 2. Option for Bright Field: Microscope specific connectors are necessary to install Bright Field unit. Specific connectors for Olympus, Nikon, Zeiss, Leica , upright/inverted microscopes are available as option.
Switching between 1 <sup>st</sup> and 2 <sup>nd</sup> camera port	1 .Light path exchange (High-end model): Motor driven: Requires CSU-X1CU-B1(Bright Field control unit) 2 Light path exchange (Basic model) Manual exchange with a port exchange lever
Camera port	1.Standard: * 1 <sup>st</sup> camera port: C mount (X 1) * 2 <sup>nd</sup> camera port position: covered 2.Option: * 2 <sup>nd</sup> camera port with C mount (X 1) * C mount adapter for EMCCD (X 1.2 for 8×8mmCCD chip) available for both 1 <sup>st</sup> /2 <sup>nd</sup> camera port * Eye piece for direct view of confocal image at 2 <sup>nd</sup> port. <b>(WARNING)</b> To install the direct view eye piece, appropriate barrier filter to cut the excitation laser has to be installed for laser safety.

Item	Specification
Accessory	<ol style="list-style-type: none"> <li>1. AC adapter</li> <li>2. AC adapter cable for AC100V</li> <li>3. Laser safety labels</li> <li>4. Interlock key for CSU-X1 unit</li> <li>5. Hexagonal wrench set</li> <li>6. Dust cover (at laser path)</li> <li>7. 2<sup>nd</sup> camera port cover</li> <li>8. Camera port support for inverted microscope installation</li> <li>9. Support screws</li> <li>10. CSU key switch</li> <li>11. Standard fiber</li> </ol>

Table 7-1-1-1 EX filter list (for EX Filter Wheel)

Laser (nm)	Ex: Chroma HQ seriesφ25
405	HQ405/40x
440-445	HQ440/40x
473-491	HQ480/40x
505-514	HQ520/40x
561-568	HQ565/30x
635-648	HQ650/45x

Table 7-1-1-2 EX filter list (for manual exchange)

Laser (nm)	Ex.: Asahi φ20
488	TXC117
568	TXC118
647	TXC119

## 7.1.2 Electrical Specifications of CSU-X1 unit

Item	Specification
External Control	1. Basic model: * Low speed: No control unit is necessary * Standard: Requires CSU-X1CU-F1(control unit) and a PC * High speed: Requires CSU-X1CU-F1(control unit) and a PC 2. High-end model: Requires CSU-X1CU-F1(control unit) and a PC
Interlock key for CSU-X1 unit (Basic model)	1. Installed: Manual shutter switch becomes valid 2. Uninstalled: Shutter closes, motor stops and manual shutter switch becomes invalid
Interlock key for control unit (High-end model)	1. Installed: Manual shutter switch becomes valid. External shutter control from PC through control unit becomes possible. 2. Uninstalled: Shutter closes, motor stops and manual shutter switch becomes invalid
DM exchange	* DM exchange should be conducted after switching off. CAUTION: Disks could be fatally damaged if DM block touches the rotating disks. * If DM holder case were opened when CSU is working, interlock works to close shutter and stop disk rotation.
Rotation speed limit	1. Basic model (w/o control unit) * Fixed at 1800rp. * Can synchronize with external pulse signal within 1500~1800rpm range 2. Basic model and High-end model (with control unit) * External rotation speed control from PC is possible * Can synchronize with external pulse signal within the designated range
Shutter control	1. Manual shutter switch inside CSU Momentary switch 2. External control PC control through CSU-X1-F1(control unit) <b>Max. allowable switch on/off is 3 times/second</b> 3. Hardware control Shutter hardware control is possible with TTL level signal input to the external input terminal of CSU-X1-F1(control unit) <b>(Maximum repeated shutter ON/OFF count per second is recommended at 3 times/sec. More frequent ON/OFF could damage shutter.)</b>
Shutter indicator	Red LED when open No light when close
Power consumption	<AC adapter> Input: 100~240VAC±10%, 50 or 60Hz, 38W> Output: 24VDC, 1.6A> <CSU Unit > Input: 24VDC, 1A>

### 7.1.3 Specifications of Control unit

Item	Specification
Rotation speed control	<ul style="list-style-type: none"> <li>*Standard: 1,500~5,000rpm (Max.1,000fps)</li> <li>* High Speed: 1,500~10,000rpm (Max.2,000fps)</li> <li>* Possible for command control of rotation speed setting.</li> <li>* Rotation speed setting/reading resolution:               <ul style="list-style-type: none"> <li>1,500~5,000rpm: 1rpm</li> <li>5,000~10,000rpm: 2rpm</li> </ul> </li> <li>* External sync is possible by pulse signal input via external signal input terminal.</li> <li>* External output terminal can send 12 pulse per one rotation</li> </ul>
DM Exchange	Command control of exchanging up to 3 DM positions in the DM block
Shutter control	Command control or external line control of shutter on/off
External I/O control	<ul style="list-style-type: none"> <li>*Digital I/O: TTL Input 4CH, Contact Input 4CH, Open Collector output 4CH, Contact output 4CH</li> <li>*External shutter control, synchronization control of CSU rotation speed, synchronization signal output, etc.</li> <li>*Analogue input: 8 ports, 0~5V, 8Bit (0~255), Response 100ms.</li> <li>*Analogue output: 4 ports, 0~5V, 8Bit (0~255), Response 10ms</li> </ul>
Filter Wheel control (CSU-X1CU-F1)	<p>Command control of filter positions</p> <p>One control unit controls up to two filter wheels</p>
Bright Field/ Camera port control (CSU-X1CU-B1)	<p>Command control of light path switching (confocal/non-confocal)</p> <p>Switch between the 1<sup>st</sup> camera port and the 2<sup>nd</sup> camera port</p>
Interlock key	<p>1.Installed:</p> <p>Manual shutter switch becomes valid.</p> <p>External shutter control from PC through control unit becomes possible.</p> <p>2.Uninstalled:</p> <p>Shutter closes, motor stops and manual shutter switch becomes invalid</p>
Communication	<p>1.Connection</p> <p>Connect control unit cable to the external interlock connector of CSU-X1 head</p> <p>Connect control unit and PC through RS232C serial cable</p> <p>Possible to connect and control two control units through daisy chain.</p> <p>2. Conditions</p> <ul style="list-style-type: none"> <li>* Speed: 115,200 bps</li> <li>* Data bit: 8</li> <li>* Parity check: None</li> <li>* Stop bit : 1</li> <li>* Line-feed character: CR</li> <li>* Separating character: colon or space</li> <li>* Case sensitivity: Yes</li> </ul>
Commands	Shown in the command list
Power consumption	Input: 100~240VAC±10%、50 or 60Hz、200VAm <sub>ax</sub>



Item	Specification
Accessory	1. AC100VAC cable 2. Bright Field1connection cable (only for CSU-X1CU-B1) 3. Bright Field2connection cable(only for CSU-X1CU-B1) 4. CSU connection cable 5. RS232C cable (cross) 6. Interlock key for control unit

#### 7.1.4 Specifications of Filter Wheel

Item	Specification
Installable filters	<ul style="list-style-type: none"> <li>* Size: <math>\varnothing 25\text{mm}</math>&gt;</li> <li>* Max. 6 filters</li> <li>* It is necessary to fill open positions with supplied dummy discs for weight balance</li> </ul>
Exchange speed	<ul style="list-style-type: none"> <li>* 33msec to the adjacent position. It is necessary to wait for 33msec&lt; before moving to the next position</li> <li>* 66msec to move two positions. It is necessary to wait for 33msec&lt; before moving to the next position</li> <li>* 99msec to move three positions. It is necessary to wait for 33msec&lt; before moving to the next position.</li> <li>* Control unit makes the filter wheel move toward shortest direction.</li> </ul>
Accessories	<ul style="list-style-type: none"> <li>* 6 Aluminum disks (dummy filter) to balance weight</li> <li>* Special tool to screw/unscrew filter fixing rings</li> <li>* Connection cable</li> </ul>
Power supply	24V DC 3.7A> Supplied from the control unit

## 7.1.5 Environment

Item	Specification
Environment	1. Operation temperature and humidity range 15~40°C, 20~75%RH. No condensation. 2. General environment -20~70 °C, 5~95%RH No condensation.*1
Dimensions	1. CSU-X1 Unit * CSU-X1-M1: 175(W)×328.5(H)×177.5(L) mm (w/o protruding parts) * CSU-X1-M2: 258.8(W)×373(H)×177.5(L) mm (Includes Bright Field, w/o protruding parts.) * CSU-X1-A1: 175(W)×328.5(H)×325.1(L) mm (Includes filter wheel, w/o protruding parts.) * CSU-X1-A2: 258.8(W)×373(H)×325.1(L) mm (Includes filter wheel and Bright Field, w/o protruding parts.) * CSU-X1-A3: 308.5(W)×328.5(H)×325.1(L) mm (Includes 2 <sup>nd</sup> camera port and filter wheel, w/o protruding parts.) 2. Control unit (CSU-X1CU) 213(W)×132(H)×438(L) mm (w/o protruding parts) 3. Filter wheel (CSU-X1FW) 112(W)×100(H)×226(L) mm (w/o protruding parts)
Weight	1. CSU-X1 Main unit: 5.5kg Camera port and filter block: 2.0kg Bright Field Unit: 2kg 2. Control unit (CSU-X1CU) 5.2kg 3. Filter wheel (CSU-X1FW) 1.9kg

\*1 Desirable environment for delivery, storage or whatever when the instrument is not in operation, under which the instrument may not suffer unrecoverable damages.

## 7.1.6 Conformity

CE marking:

EMC Directive : EN61326、 EN61000-3-2、 EN61000-3-3

Low Voltage Directive : EN61010-1

Measurement category (\*1)

Pollution Degree 2 (\*2)

- \*1: To measure circuit connected to low voltage units, applied on electrical instruments which has power supply from fixed power switchboard.
- \*2: Degree of adhesion of any solid, liquid or gas which may lower surface resistance or electric strength, applied to normal room atmosphere.

FDA Laser Safety Regulation: Applied on August, 2007.

## 7.1.7 Global Environment Action

Lead free solder is used.

Lead free glass is used.

No use of Cr+6 for chromium plating: Will be completed by March, 2008.

## 7.2 Model and Suffix Code (MS Code)

Table 7-2-1 CSU-X1 Basic Specification Codes

Model	Model Code	Specification
<b>CSU-X1</b>	.....	Confocal scanner unit model CSU-X1
Main unit	-A1..... -A2..... -A3..... -M1..... -M2.....	High-end Model High-end Model (with BrightField) High-end model (with Second camera) Basic Model Basic model (with BrightField)
Rotation speed	H ..... N ..... L .....	High Speed (10000rpm) Standard (5000rpm) Low Speed (1800rpm)
Language of labels	-J ..... -E .....	Japanese English

(\*) 1800 rpm is for CSU-X1-M1 and -M2 ONLY

Table 7-2-2 CSU-X1 Suffix Code: DM (Dichroic Mirror) and BA (Barrier Filter) or fiber Selection

Suffix Code	Laser line	Example of Dyes
Dichroic Mirror (DM)	/D*000	488nm EGFP, FITC
	/D*001	532nm TRITC
	/D*002	568nm DsRed, mRFP
	/D*100	445/488 ECFP, EGFP, FITC
	/D*101	442/505/635nm ECFP, EYFP, Cy5
	/D*200	405/473-491/568/635-647nm DAPI, EGFP, FITC, DsRed, mRFP, Cy5
	/D*201	445/514/635-647nm ECFP, EYFP, Cy5
Barrier Filter (BA)	/B#100	405nm DAPI
	/B#101	440-445nm ECFP
	/B#102	473-491nm EGFP, FITC
	/B#103	473-496nm (ArKr laser) EGFP, FITC
	/B#104	505nm, 514nm EYFP
	/B#105	532nm TRITC
	/B#106	561nm, 568nm DsRed, mRFP
Fiber	/B#107	635-647nm Cy5
	/FB1	405-650nm With the standard fiber

\*: means DM position: 0 for M (Manual Model), 1,2,3 for A(High-end model) to indicate DM position. No duplicate numbers can be assigned.

#: means BA position: 0 for M (Basic model) In the case of A (High-end model), please refer to Suffix code of CSUX1-FW (Filter wheel).

Table 7-2-3 Basic Specification of Control Unit

Model	Basic Code	
<b>CSUX1CU</b>		
Main Unit	<b>-F1</b>	Filter Wheel Control
	<b>-B1</b>	Bright Field Control
:Language of label	<b>-J</b>	Japanese
	<b>-E</b>	English

Table 7-2-4 Basic Specification of Filter Wheel Unit

Model	Basic Code	
<b>CSUX1FW</b>		
Filter position	<b>-06P</b>	6 Positions
Channel No.	<b>-01</b>	First Camera port
	<b>-02</b>	Second Camera Port

- Please select filters as suffix code.
- Please indicate positions of BA filters to be installed in the filter wheel by numbers 1 to 6. No duplicate number is accepted.

## 7.3 Dimension

### 7.3.1 CSU-X1-A1

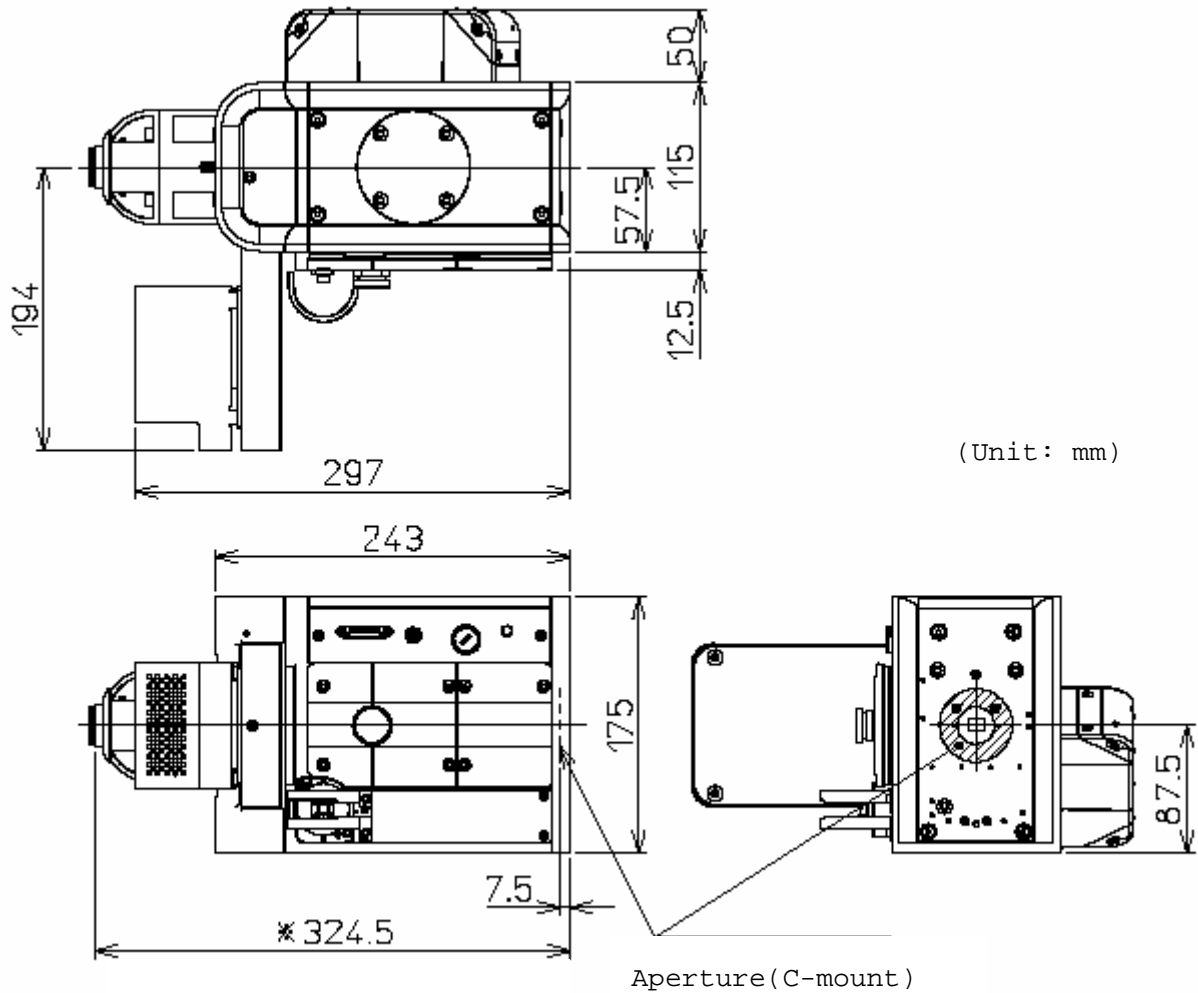

Total width of CSU-X1-A1 main unit is 328.5mm including 4mm of the screw head of C-mount adapter of main camera port.

Please connect CSU-X1-A1 to microscope with the direct C-mount adapter of your microscope.

### 7.3.2 CSU-X1-A2

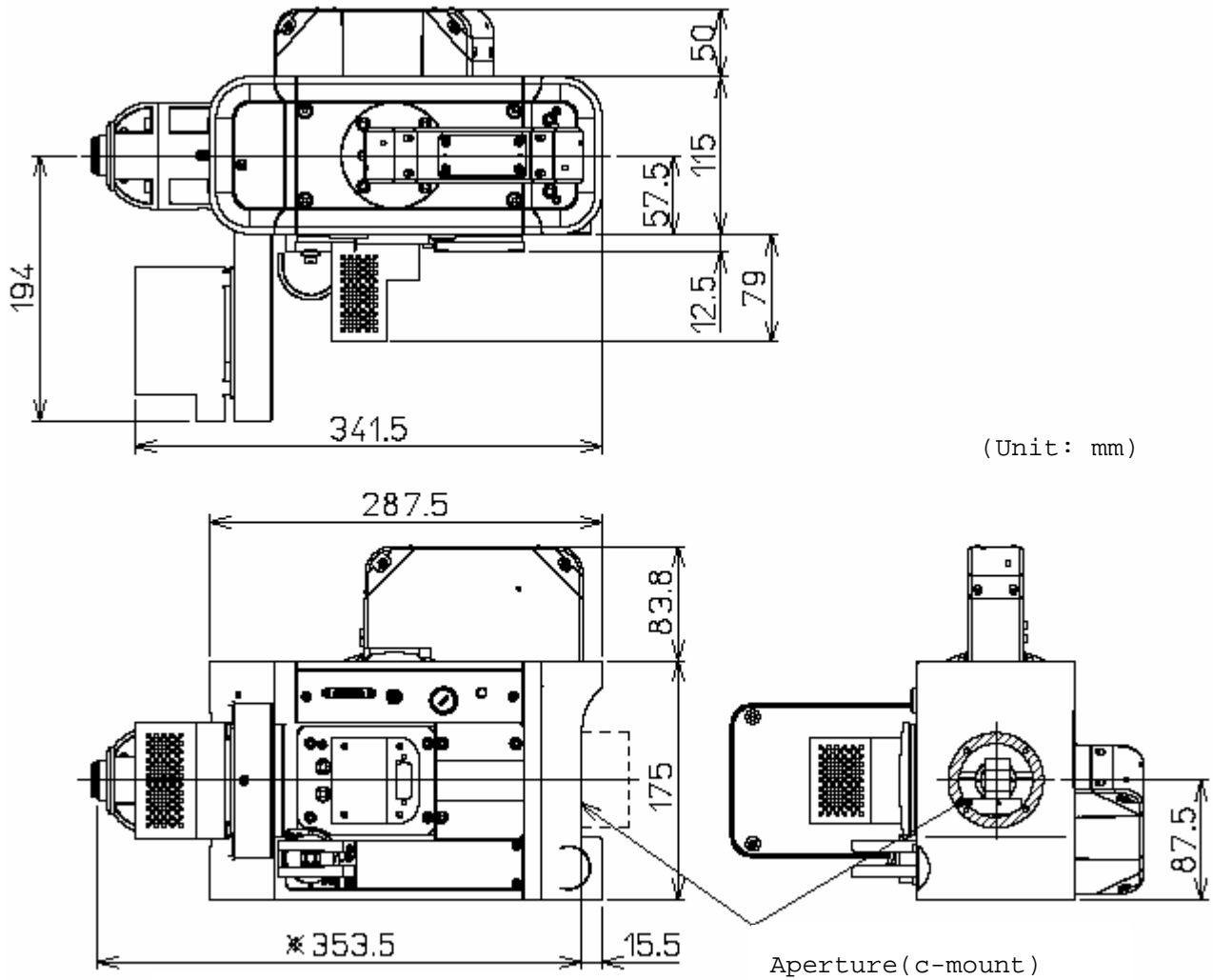

Total width of CSU-X1-A2 main unit is 328.5mm including 4mm of the screw head of C-mount adapter of main camera port.

Please connect CSU-X1-A2 to microscope with microscope specific adapter made by Yokogawa and supplied as option.

### 7.3.3 CSU-X1-A3

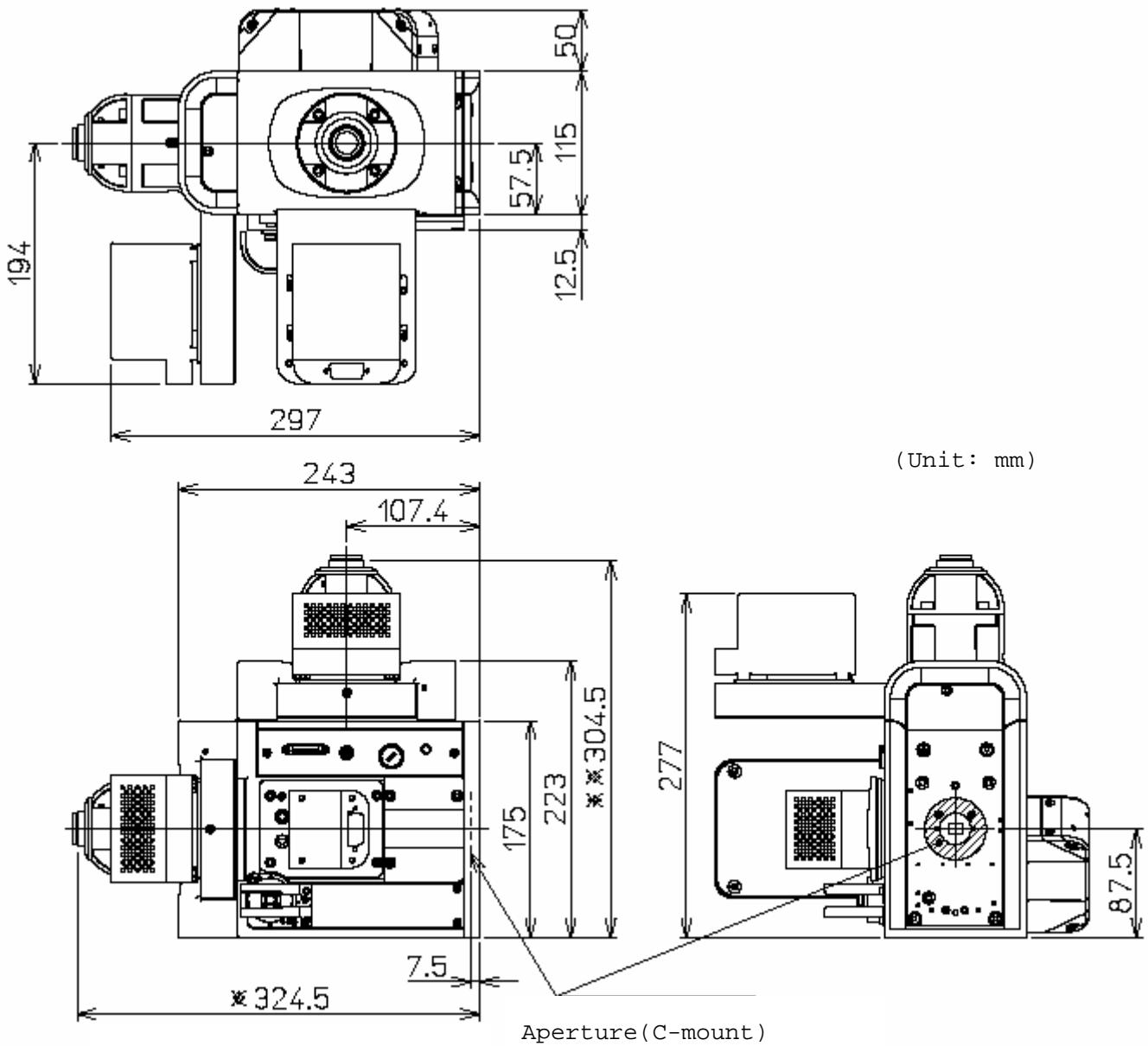

Total height of CSU-X1-A3 main unit is 308.5mm including 4mm of the screw head of C-mount adapter of second camera port.

Please connect CSU-X1-A3 to microscope with the direct C-mount adapter of your microscope.



### 7.3.4 CSU-X1-M1

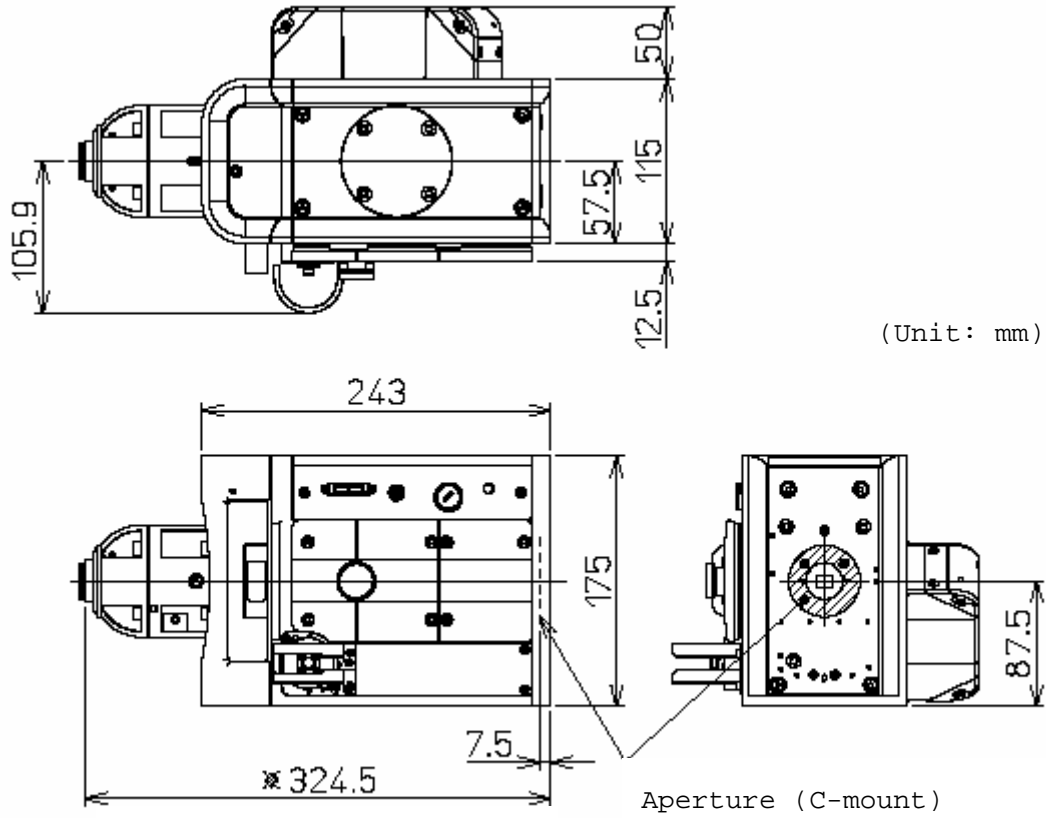

Total width of CSU-X1-M1 main unit is 328.5mm including 4mm of the screw head of C-mount adapter of main camera port.

Please connect CSU-X1-M1 to microscope with the direct C-mount adapter of your microscope.

### 7.3.5 CSU-X1-M2

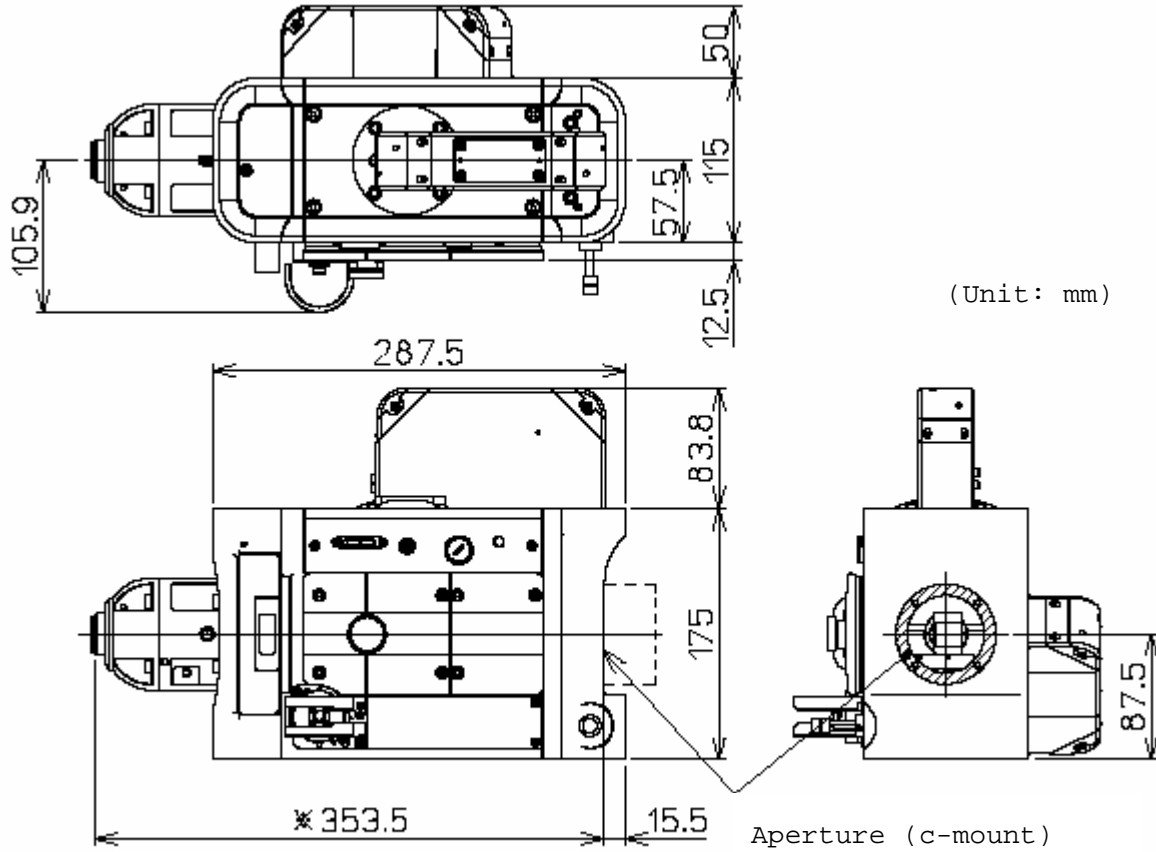

Total width of CSU-X1-M2 main unit is 328.5mm including 4mm of the screw head of C-mount adapter of main camera port.

Total height of CSU-X1-M2 main unit is 308.5mm including 4mm of the screw head of C-mount adapter of second camera port.

Please connect CSU-X1-M2 to microscope with microscope specific adapter made by Yokogawa and supplied as option.

### 7.3.6 CSU-X1CU

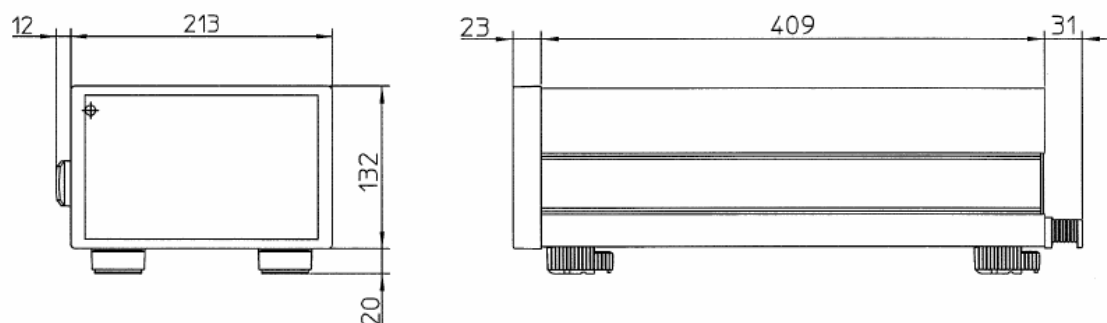

(Unit: mm)

### 7.3.7 CSU-X1FW

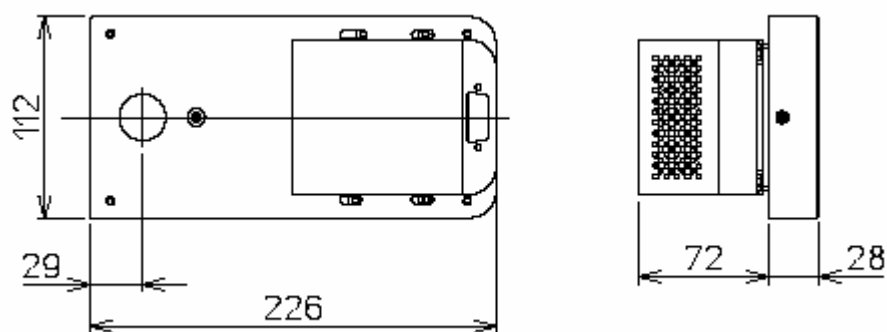

(Unit: mm)

## 7.4 Control Signal

Table 7-4-1 PCR28 pin(male) connector of CSU-X1 main unit

Pin No.	Signal Name	Function	I/O	Connection
1	Reserved			
2	Reserved			
3	SHUTTER*1	High: Open, Low: Close	Input	TTL/CMOS level
4	Reserved			
5	Reserved			
6	Reserved			
7	SYNC	Sync trigger signal input	Input	TTL/CMOS level
8	INDEX	Sync trigger signal output Pulse width 10ms<, 300Hz-2kHz	Output	TTL/CMOS level
9	Interlock	Open for Interlock	Input	TTL/CMOS level
10	Reserved			
11	Reserved			
12	Reserved			
13	PORT	M6 port position signal	Output	TTL/CMOS level
14	Reserved			
15	Reserved			
16	Reserved			
17	Reserved			
18	Reserved			
19	Reserved			
20	Reserved			
21	SYNC-	GND		
22	INDEX-	GND		
23	Interlock-	GND		
24	Reserved			
25	Reserved			
26	Reserved			
27	PORT-	GND		
28	Reserved			

\*1: For the protection of shutter, maximum allowable On/Off frequency is 3Hz. If you input faster signal, shutter may not work properly.

Table 7-4-2 PCR68 pin (male) connector of Control unit

Pin No.	Signal name	Function	I/O	Connection
1	TI1(EI1)*1	TTL input ch1	Input	TTL level 
2	TI2(EI2)*1	TTL input ch 2	Input	
3	TI3(EI3)*1	TTL input ch3	Input	
4	TI4(EI4)*1	TTL input ch4	Input	
5	VCOM1	Source for contact input VCOM1	Input	For contact input source (DC5V) 
6	VCOM2	Source for contact input VCOM2	Input	
7	VCOM3	Source for contact input VCOM3	Input	
8	VCOM4	Source for contact input VCOM4	Input	
9	Interlock+	Open is Interlock	Input	Connect with 43pin
10	Reserved			
11	Reserved			
12	CSU_SYNC	CSU sync signal input 300Hz-2kHz "limitation exists in the rotation speed"	Input	TTL/CMOS level 
13	SHUTTER*5	External shutter control signal H:Open, L:Close	Input	
14	OC1(EO1)*2	Open collector output1, H is ON	Output	DC5V 100mA max 
15	OC2(EO2)*2	Open collector output 2, H is ON	Output	
16	OC3	Open collector output 3, H is ON	Output	
17	OC4	Open collector output 4, H is ON	Output	
18	DO1+(EO5)* 3	Contact output 1+, H is ON	Output	DC30V 500mA max 
19	DO2+(EO6)* 3	Contact output 2+, H is ON	Output	
20	DO3+(EO7)* 3	Contact output 3+, H is ON	Output	
21	DO4+(EO8)* 3	Contact output 4+, H is ON	Output	
22	Reserved			
23	Reserved			
24	Reserved			

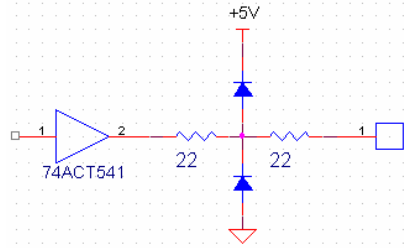
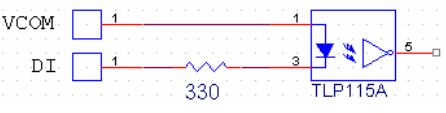
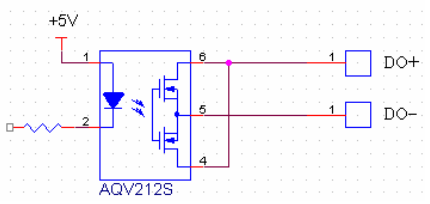
25	Reserved			
26	Reserved			
27	CSU_INDEX	CSU rotation sync signal 300-2kHz	Output	TTL level 
28-31	Reserved			
32-34	5V	5VDC	Output	100mA max
35	GND	GND		
36	GND			
37	GND			
38	GND			
39	DI1(EI5)*4	Photo coupler input 1	Input	DC5V 7~20mA
40	DI1(EI5)*4	Photo coupler input 2	Input	
41	DI1(EI5)*4	Photo coupler input 3	Input	
42	DI1(EI5)*4	Photo coupler input 4	Input	
43	Interlock-	Interlock-	Input	Connect with pin 9
44	GND			
45	GND			
46	GND			
47	GND			
48	GND			
49	GND			
50	GND			
51	GND			
52	DO1-	Contact output 1-	Output	
53	DO2-	Contact output 2-	Output	
54	DO3-	Contact output 3-	Output	
55	DO4-	Contact output 4-	Output	
56-68	GND			

\*1 : Possible to acquire input terminal ch1-ch4 levels: EI,[ch],?

\*2 : Possible to assign output terminal ch1-ch4 levels: EO,[ch],[n]

\*3 : Possible to assign output terminal ch5-ch8 levels: EO,[ch],[n]

\*4 : Possible to acquire input terminal ch5-ch8 levels: EI,[ch],?



**WARNING**



**CAUTION**

\*5: Please control shutter ON/OFF below 3Hz. Faster ON/OFF control may damage the shutter.

Please do not open the dichroic mirror block cover when you input shutter control signal. If you do so, shutter closing timing could delay and laser beam may leak out.

Table 7-4-3 PCR36 pin (male) connector for control unit

Pin No.	Signal Name	Function	I/O	Connection
1	AD1 *1	Analogue input 1CH	Input	Resolution 0-5V 10bit Precision 8bit 
2	AD2 *1	Analogue input 2CH	Input	
3	AD3 *1	Analogue input 3CH	Input	
4	AD4 *1	Analogue input 4CH	Input	
5	AD5 *1	Analogue input 5CH	Input	
6	AD6 *1	Analogue input 6CH	Input	
7	AD7 *1	Analogue input 7CH	Input	
8	AD8 *1	Analogue input 8CH	Input	
9	DA1 *2	Analogue output 1CH	Output	Resolution 0-5V 12bit Precision 8bit 
10	DA2 *2	Analogue output 2CH	Output	
11	DA3 *2	Analogue output 3CH	Output	
12	DA4 *2	Analogue output 4CH	Output	
13	NC	Unconnected		
14	NC	Unconnected		
15	NC	Unconnected		
16	NC	Unconnected		
17	NC	Unconnected		
18	Reserved			
19-30	GND A	Analogue GND		
31-35	NC	Unconnected		
36	GND A	Analogue GND		

\*1 : Possible to acquire AD ch1-ch8 data: AD\_DATA,[ch],?

\*2 : Possible to assign AD ch1-ch8 output value: DA\_DATA,[ch],[n]

Table 7-4-4 RS232C1 D-Sub9 pin connector for control unit

Pin No.	Signal Name	Function	I/O	Connection
1	NC	Unconnected		
2	RXD		Input	RS232C compliant
3	TXD		Output	RS232C compliant
4	NC	Unconnected		
5	GND			
6	NC	Unconnected		
7		Short circuit with pin 8		
8		Short circuit with pin 7		
9	NC	Unconnected		

Table 7-4-5 RS232C2 D-Sub9 pin connector for control unit

Pin No.	Signal Name	Function	I/O	Connection
1	NC	Unconnected		
2	RXD		Input	RS232C compliant
3	TXD		Output	RS232C compliant
4	NC	Unconnected		
5	GND			
6	NC	Unconnected		
7		Short circuit with pin 8		
8		Short circuit with pin 7		
9	NC	Unconnected		

Table 7-4-6 MOTOR1 D-Sub15 pin connector for control unit 1(CSU-X1CU-F1)

Pin No.	Function	I/O	Connection
1	MOTOR1 output	Output	
2	MOTOR1 output	Output	
3	MOTOR1 output	Output	
4	MOTOR1 output	Output	
5	MOTOR1 output	Output	
6	MOTOR1 output	Output	
7	MOTOR1 output	Output	
8	MOTOR1 output	Output	
9	Unconnected		
10	Unconnected		
11	Sencer input	Input	
12	Unconnected		
13	Unconnected		
14	Source for sensor (24V)		
15	GND for sensor		



Table 7-4-7 MOTOR2 D-Sub15 pin connector for control unit 1(CSU-X1CU-F1)

Pin No.	Function	I/O	Connection
1	MOTOR2 output	Output	
2	MOTOR2 output	Output	
3	MOTOR2 output	Output	
4	MOTOR2 output	Output	
5	MOTOR2 output	Output	
6	MOTOR2 output	Output	
7	MOTOR2 output	Output	
8	MOTOR2 output	Output	
9	Unconnected		
10	Unconnected		
11	Sensor input	Input	
12	Unconnected		
13	Unconnected		
14	Source for sensor (24V)		
15	GND for sensor		

Table 7-4-8 MOTOR1 D-Sub15 pin connector for control unit 2(CSU-X1CU-B1)

Pin No.	Function	I/O	Connection
1	Unconnected		
2	Unconnected		
3	Unconnected		
4	Unconnected		
5	Unconnected		
6	Unconnected		
7	Unconnected		
8	MOTOR1output	Output	
9	MOTOR1output	Output	
10	MOTOR1output	Output	
11	Sensor input	Input	
12	MOTOR1output	Output	
13	MOTOR1output	Output	
14	Source for sensor		
15	GND for sensor		

Table 7-4-9 MOTOR2 D-Sub15 pin connector for control unit 2(CSU-X1CU-B1)

Pin No.	Function	I/O	Connection
1	Unconnected		
2	Unconnected		
3	Unconnected		
4	Unconnected		
5	Unconnected		
6	Unconnected		
7	Unconnected		
8	MOTOR1output	Output	
9	MOTOR1output	Output	
10	MOTOR1output	Output	
11	Sensor input	Input	
12	MOTOR1output	Output	
13	MOTOR1output	Output	
14	Source for sensor(24V)		
15	GND for sensor		

## 8 Command list

Main Item	Detailed item	Function	Command
CSU control	Shutter	Open shutter	SHO
		Close shutter	SHC
		Acquire shutter status	SH, ?
		Acquire open/close count	SH_CNT, ?
	Disk	Assign disk rotation speed [rpm]	MS, [n]
		Fine adjustment of disk rotation speed to increase	MS+
		Fine adjustment of disk rotation speed to decrease	MS-
		Acquire disk rotation speed [rpm]	MS, ?
		Acquire upper limit of disk rotation speed [rpm]	MS_MAX, ?
		Automatic adjustment to camera exposure time [ms]	MS_ADJUST, [f]
		Run disk rotation	MS_RUN
		Stop disk rotation	MS_STOP
	Dichroic mirror	Assign dichroic mirror position	DM_POS, [n]
Acquire dichroic mirror position		DM_POS, ?	
Filter Wheel control		Assign Filter Wheel position	FW_POS, [ch], [n]
		Acquire Filter Wheel position	FW_POS, [ch], ?
Bright Field control (Port switching control)	Bright Field	Move Bright Field port to the original point	BF_INIT
		Switch port to confocal position	BF_OFF
		Switch port to Bright Field position	BF_ON
		Acquire current position	BF_POS, ?
	Port	Assign Port position	PT_POS, [ch], [n]
		Acquire Port position	PT_POS, [ch], ?
External IO control	General purpose IO	Assign output terminal level	EO, [ch], [n]
		Acquire appointed level of output terminal	EO, [ch], ?
		Acquire input terminal level	EI, [ch], ?
	General purpose DA	Set DA output parameter	DA_DATA, [ch], [n]
	General purpose DA General purpose AD	Set DA output parameter	DA_DATA, [ch], [n]
General purpose AD	Acquire AD input value	AD_DATA, [ch], ?	
Memory control	Save memory	Save parameters	SAVE_MEM
		Save Filter Wheel information (max.16 letters)	FW_INFO, [ch], [n] "XXXX"
		Save dichroic mirror information (max. 16 letters)	DM_INFO, [n], "XXXX"
	Memory load	Load parameters from memory	LOAD_MEM
		Load default parameter	LOAD_INIT
		Acquire Filter Wheel information	FW_INFO, [ch], [n], ?
		Acquire dichroic mirror information	DM_INFO, [ch], ?
Hardware information	CSU Information	Acquire serial number of CSU	SERIAL_CSU, ?
		Acquire product ID of CSU	PRODUCT_CSU, ?

	Error information	Acquire error ID	ERRID, ?
	Connection status	Acquire hardware connections	SYSTEM, ?
	Software information	Acquire software version	VER, ?
		Acquire build time of software	BULIDTIME, ?
	Hardware misc.	Output error ID log	LOG_ON
		Not to output error ID log	LOG_OFF
		Acquire connection status of own control unit	SYSTEM_THIS, ?
		Acquire connection status of extension control unit	SYSTEM_EXT, ?

#### Command notation

- \* colon or (space) : delimiter
- \* [ch] : channel number of connected instruments
- \* [n] : integral number parameter
- \* [f] : decimal number parameter
- \* "xxxx" : letter string parameter

## 9 Warranty

- The term of warranty is for one year after the day of purchase. Yokogawa Electric Corporation will repair the Product at no charge during the term of warranty.
- This warranty covers only this instrument.
- Yokogawa Electric Corporation cannot be held liable for damages resulting from operating errors, improper use, handling or storage, unauthorized repair or modification of this instrument by the customer, transportation, fire, natural disasters (such as earthquake, flood, thunderbolt, etc.), salt damages, corrosive gas damages, or abnormal voltage, moving or dropping this instrument after delivery, or any other damages for which Yokogawa Electric Corporation is not responsible.
- Please contact either Yokogawa Electric Corporation or your representative if you want to request for repair.

### Contact:

Yokogawa Electric Corporation,  
Life Science Business Headquarters,  
Bio Center  
E-Mail: [csu@csv.yokogawa.co.jp](mailto:csu@csv.yokogawa.co.jp)  
Tel: 81-(0) 76-258-7028  
Fax: 81-(0) 76-258-7029



---

**User's  
Manual**

**CSU Control Unit CSUX1CU**

**IM 85A7C26-02E**

---





## Table of content

1	Safety Precautions .....	3
1.1	Introduction.....	3
1.2	Caution.....	3
1.3	History.....	3
1.4	General Safety Precautions.....	4
2	Product Overview.....	7
2.1	Product Overview.....	7
3	Before Use .....	8
3.1	Packing List .....	8
3.1.1	CSU Filter Wheel Control Unit (CSUX1CU-F1).....	8
3.1.2	CSU Bright Field Control Unit (CSUX1CU-B1) .....	8
3.1.3	Option: Filter Wheel (CSUX1FW).....	9
3.2	Precautions.....	10
3.2.1	Safety Precautions.....	10
3.2.2	General precautions on handling.....	10
3.3	Installation.....	11
3.3.1	Installation requirements.....	11
3.3.2	Connection.....	12
3.3.3	Power On.....	17
4	Name and Function.....	18
5	Maintenance.....	20
5.1	Circuit Breaker .....	20
6	Specification .....	22
6.1	Product Specification .....	22
6.1.1	Control Unit .....	22
6.1.2	Filter Wheel (Option).....	23
6.1.3	Environment .....	24
6.1.4	Conformity .....	25
6.1.5	Global Environment Action.....	25
6.2	Model and Suffix Code (MS Code).....	26
6.3	Dimension of CSUX1CU .....	26
6.4	External Input/Output.....	27
6.5	Command List.....	34
7	Warranty.....	36



# 1 Safety Precautions

## 1.1 Introduction

Thank you so much for purchasing CSUX1CU: Control Unit for CSU.

This manual covers the features, operation methods and procedures, safety and handling precautions of the CSUX1CU.

Before you start to use the unit, read this manual thoroughly and operate the unit in a proper manner.

Please, keep this manual in a safe place for future quick reference.

## 1.2 Caution

- No part of the user's manuals may be transferred or reproduced without prior written consent from YOKOGAWA.
- YOKOGAWA continues to improve the product's performance and features, and for this reason, the specifications and information herein are subject to change at any time and without notice.
- The authors and publishers of this manual have used their best efforts in preparing this document, but make no representation or warranties with respect to the accuracy, applicability, fitness, or completeness of the contents of this manual. If you have noticed any problems or have any suggestions for the manual, please contact us.
- To maintain long-term, stable performance of the product, please observe the operation instructions in this manual.

## 1.3 History

1<sup>st</sup> Edition: August, 2007

-

## 1.4 General Safety Precautions

For the protection and safe use of this instrument, be sure to follow the instructions on safety described in this manual when handling this instrument. If you use the instrument in a manner not specified in this manual, the protection provided by this instrument may be impaired. In addition, Yokogawa Electric Corporation assumes no liability for the customer's failure to comply with these requirements.

The following symbols are used on the instrument:



Both of the above two symbols indicate that important content is mentioned. The symbols are given wherever you are required to refer to the manual in order to avoid personal injury and/or damage to the instrument.

The following symbols are used in this manual.



This symbol indicates that the operator must refer to an explanation in the user's manual in order to avoid serious injury or death and/or damage to the instrument.



This symbol indicates that the operator must refer to an explanation in the user's manual in order to avoid minor injury and/or damage to the instrument.

To reduce the risk of injury of personnel such as electric shock or and/or damage to the instrument, please comply the following precautions:



## WARNING

- Power supply
- Ensure the source voltage matches the voltage of the power supply before turning on the power. Please only use supplied power cable.
- Power strip and plug
- To avoid electric shock or fire, please only use power code supplied by YOKOGAWA. Be sure to connect main power supply plug with grounded power receptacle. If you use extension code without protective earth terminal, protected operation becomes invalid.
- Protective earth
- To avoid electrical shock, ensure the protective earth before turning on the power. The power supply code of CSUX1CU is a tripolar power strip with earthing conductor, thus please use tripolar power receptacle with protective earth terminal.
- Necessity of the protective earth
- Do not cut internal or external protective earth conductor, or unfix the wire connection of the protective earth terminal, otherwise, this instrument may get in danger..
- Defection of protective function
- Never operate this instrument if protective function seems to be defective. Please confirm protective function before you use this instrument.
- Use under gas
- It is extremely dangerous to use this instrument under the atmosphere with explosive or evaporating gas, or vapor.
- Disassembly of the case
- There are high-voltage parts inside this instrument. Never disassemble the case except by the authorized service person..
- External connection
- Ensure the protective earth before connecting to this instrument.



## CAUTION

- This instrument is used in combination with CSU-X1 confocal scanner unit, filter wheel, laser system, microscope, and cameras, to be purchased separately. In addition to this manual, read carefully the user's manual of the respective products and follow their instructions.

- To avoid damage to this instrument, make sure to use input and output terminals within their specification..
- This instrument is a precision optical instrument. Do not use this instrument in areas with excessive vibration, or dust, high humidity, excessive heat (near heat sources or under direct sunlight), sudden temperature change (where condensation could occur), corrosive or flammable gas, etc.
- In case of mechanical trouble, never touch inside the instrument, and contact Yokogawa Electric Corporation or its representative.

## 2 Product Overview

### 2.1 Product Overview

CSUX1CU controls Confocal Scanner Unit Model CSU-X1.

Major functions of CSUX1CU are shown below.

- \* CSU scanning speed (Max. speed varies depending on CSU-X1 Models.)
- \* Dichroic mirror movement (High-end Models)
- \* CSU Shutter ON/OFF (Command level or external control)
- \* External Input/Output signal control
- \* Filter Wheel (CSUX1FW) movement (CSUX1CU-F1 type)
- \* Bright Field port switching (CSUX1CU-B1type)
- \* Interlock
- \* Communication (RS232C)

(Fig. 2-1) CSUX1-A2Model: CSUX1CU-F1and CSUX1CU-B1



### 3 Before Use

#### 3.1 Packing List

##### 3.1.1 CSU Filter Wheel Control Unit (CSUX1CU-F1)

Name	Parts No.	QTY	Usage
Filter Wheel Control unit	M3918EA	1	To control FW
Source cable	A1006WD	1	UL,CSA standard
Controller Interlock cable	M3918AN	1	Interlock cable for CSU control 2.5m shield cable
Communication cable	M3918WA	1	Serial cross cable, DSUB 9pin, female-female,3m shield cable
Controller Interlock key	M3918AT	1	Interlock key for CSU control unit

##### 3.1.2 CSU Bright Field Control Unit (CSUX1CU-B1)

Name	Parts No.	QTY	Usage
Bright Field Control Unit	M3918EB	1	To control Bright Field
Source cable	A1006WD	1	UL,CSA standard
Bright Field1 Cable	M3918AR	1	Bright Field1 connection cable 2.5m shield cable
Bright Field2 Cable	M3918AS	1	Bright Field2 connection cable 2.5m shield cable
CSU Control unit cable *1	M3918AN	1	Interlock cable to control CSU 2.5m shield cable
Communication cable	M3918WA	1	Serial cross cable, DSUB 9pin, female-female,3m shield cable
Controller Interlock key	M3918AT	1	Interlock key for CSU control unit

\*1: This is not supplied if you already have a CSUX1CU-F1



### 3.1.3 Option: Filter Wheel (CSUX1FW)

Necessary for CSUX1-A1,-A2,-A3 or CSUX1-M1N,-M1H,-M2N,-M2H

Part name	Part number	QTY	Description
Filter wheel	M3918MA	1	Filter wheel
Aluminum disc for weight balance	M3916MW	6	Aluminum disc to fill open positions in the filter wheel for weight balance
Connection cable 1 *1	M3918AP	1	Connection cable for filter wheel 1 2.5m shield cable
Connection cable 2 *1	M3918AQ	1	Connection cable for filter wheel 2 2.5m shield cable
Filter Wrench	M3916CX	1	Tool for exchanging filters in the filter wheel

\*1: Connection cable 1 is supplied with CSUX1FW-06P-01, and Connection cable 2 is supplied with CSUX1FW-06P-02



#### CAUTION

You have to use attached cables ONLY, otherwise, it is possible to fail EMC conformity.

## 3.2 Precautions

### 3.2.1 Safety Precautions

- Before you start to use the unit, please read this manual thoroughly
- Do not remove the cover to avoid risk of burn injury, since some parts inside the unit could become high temperature. Please contact Yokogawa Electric Corporation or its representative, when you need inspection or adjustment of this instrument.
- In case of such abnormal status as unusual odor or smoke goes up from this instrument, turn off the power switch and disconnect power code. Please contact Yokogawa Electric Corporation or its representative in such unusual case.
- Do not put any objects on the cable. Do not let the cable touch heating objects. When you disconnect the cable, do not pull the cable but always pull the connector. In case a cable was damaged, please contact your local representative for replacement order. You may find necessary parts number in the packing list of this manual.

### 3.2.2 General precautions on handling

- Please do not place any liquid-containing objects on this unit, since liquid spilling could damage the unit.
- Be careful not to add mechanical shock or drop the unit, which could result in severe damage. Application of mechanical shock to the cable could cause electric noise which may lead to malfunction. .
- Avoid bringing any charged object close to the terminal, which may cause failure.
- Please be most careful when you carry this unit. Remove the connecting cable first, then use the handle on this unit to carry. This unit weighs about 5 kg.
- Please do not wipe the plastic surface with organic solvents such as benzene or paint thinner, which may cause discoloration. When the surface of the unit gets dirty, please clean with soft cloth wet with dilute solvent, and then wipe with a dry cloth.

## 3.3 Installation

### 3.3.1 Installation requirements

Please use the FW under the following environment.

Ambient air temperature: 15~40℃

Ambient humidity: 20~75%RH (No dew condensation.)



#### CAUTION

- Dew formation inside the unit may occur when you move the unit between much different temperature/humidity environments. In such case, please wait for an hour or more until condensation resolved before use.

#### <Ventilation>

Please be careful to secure enough space around the ventilation hole of the unit placed at the motor cover to avoid overheating.,

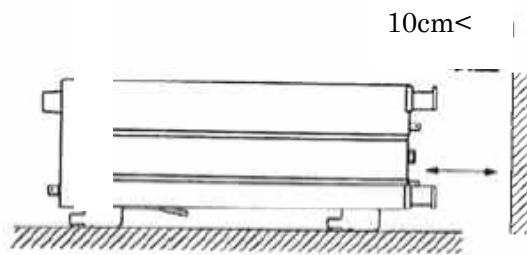
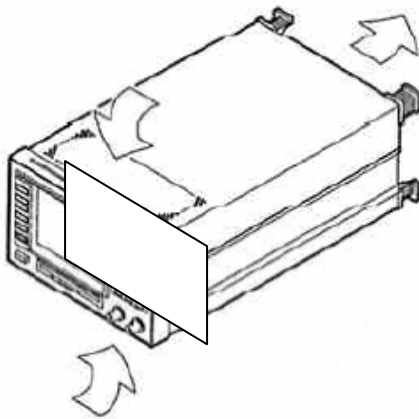



## CAUTION

Please do not install the unit under the following conditions.

- Under direct sunlight
- Close to heating objects
- Polluted with oily smoke, steam, dusts or corrosive gas
- Close to any objects with heavy electromagnetic field
- Close to high-voltage apparatus or a power line
- Under heavy mechanical vibration
- Unstable place

< Installation >

Please install the unit horizontally.

### 3.3.2 Connection

#### 3.3.2.1 CSUX1CU-F1 Model

- (1) Connect EXT CONTROL / INTERLOCK of CSU-X1 with the CSU connector of control unit ;CSUX1CU-F1, with supplied cable.
- (2) Connect controller interlock key to EXT INTERFACE1/I.LOCK.
- (3) For communication, connect RS232C1 connector of control unit with PC using supplied RS232C cable.
- (4) To use Filter Wheel, connect FW1 and MOTOR1 connector with supplied FW1 cable.
- (5) To connect second FW, connect FW2 and MOTOR 2 connector with supplied FW2 cable.
- (6) After checking the power switch is OFF, connect the power cable

Please use the power receptacle which fulfills the following conditions.

- \* 3 pole electric socket equipped with protective earth terminal.
- \* Rated supply voltage: 100~240VAC
- \* Power voltage frequency range: 90~264VAC
- \* Rated supply frequency: 50~60Hz
- \* Power frequency latitude: 48~63Hz
- \* Maximum electric power consumption: 200VA

Please follow the warnings and cautions below before connecting the power supply of a control unit. If these warning and cautions were not followed, there is a possibility of causing an electric shock or breakage of apparatus.



## WARNING

- Please confirm your power supply is suitable for the rated supply voltage of this unit before connection.
- Please confirm before connecting the power cord if the power switch of this unit is off.
- Please ONLY use supplied power code to prevent electrical shock or fire.
- Please be sure to ground the protective earth for electric shock prevention.
- Please always use 3-prong plug with protective earth terminal to avoid risk of electrification.
- Please do not use the extension code without a protective earth conductor. Use of such will cancel out protection.

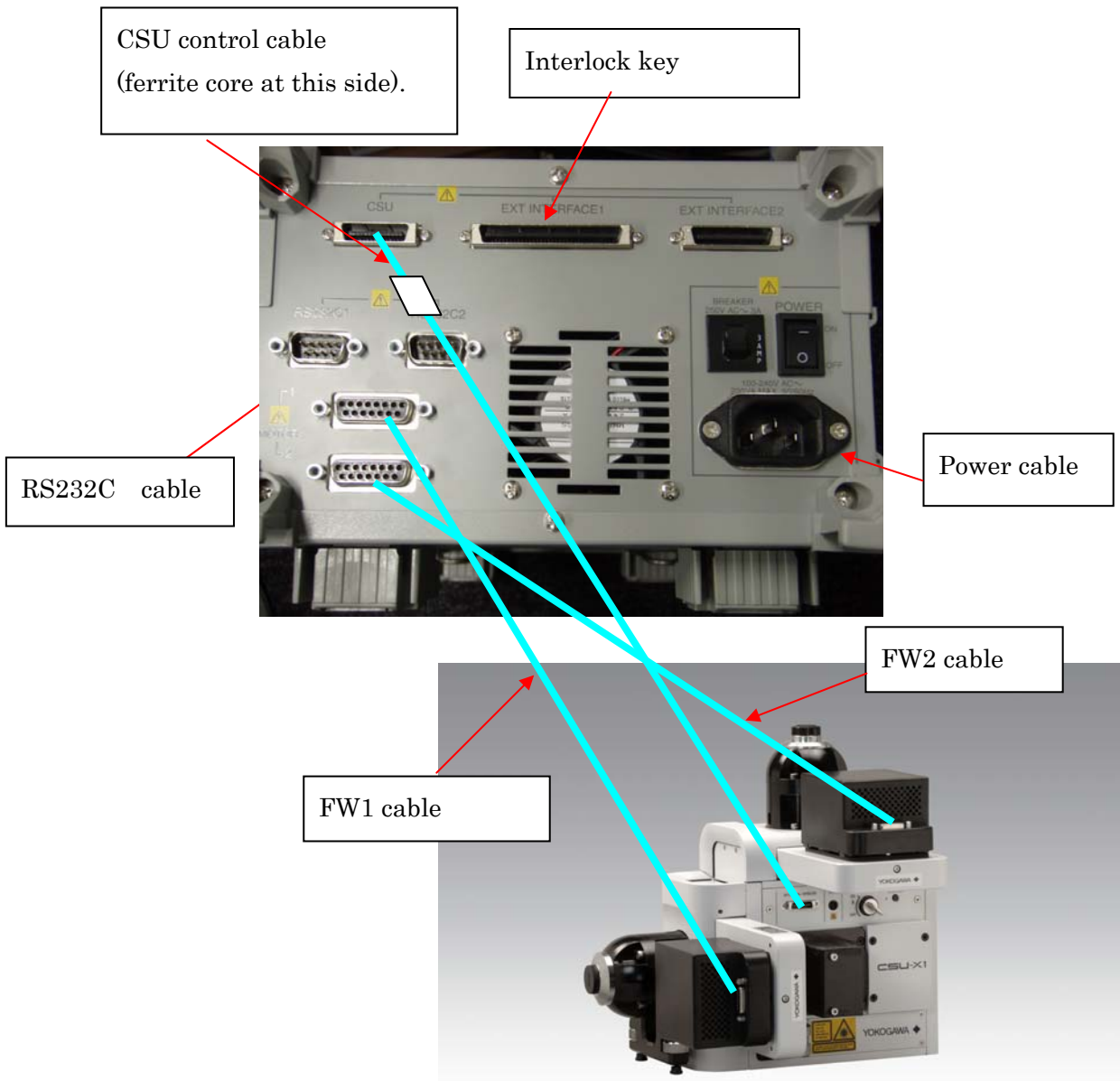

## CAUTION

Please ONLY use attached cables, otherwise, it is possible to fail EMC conformity.

### 3.3.2.2 CSUX1CU-B1 Model

Following connection is necessary to use Bright Field with CSUX1-A2 and A3 models.

- (1) Connect RS232C2 connector of control unit 1 (CSUX1CU-F1) and RS232C1 connector of control unit 2 (CSUX1CU-B1) with supplied cable.
- (2) Connect controller interlock key to EXT INTERFACE1/I.LOCK.
- (3) Connect MOTOR1 of control unit 2 (CSUX1CU-B1) and BF1 connector of CSU-X1 with supplied Bright Field cable (BF1).
- (4) Connect NOTOR2 and BF2 connector with supplied Bright Field 2(BF2) cable.  
(Not necessary for A3 model.)
- (5) After checking the power switch is OFF, connect the power cable

Please use the power receptacle which fulfills the following conditions.

- \* 3 pole electric socket equipped with protective earth terminal.
- \* Rated supply voltage: 100~240VAC
- \* Power voltage frequency range: 90~264VAC
- \* Rated supply frequency: 50~60Hz
- \* Power frequency latitude: 48~63Hz
- \* Maximum electric power consumption: 200VA

Please follow the warnings and cautions below before connecting the power supply of control unit. If these warning and cautions were not followed, there is a possibility of causing an electric shock or breakage of apparatus.



#### WARNING

- Please confirm your power supply is suitable for the rated supply voltage of this unit before connection.
- Please confirm before connecting the power cord if the power switch of this unit is off.
- Please ONLY use supplied power code to prevent electrical shock or fire.
- Please be sure to ground the protective earth for electric shock prevention.
- Please always use 3-prong plug with protective earth terminal to avoid risk of electrification.
- Please do not use the extension code without a protective earth conductor. Use of such will cancel out protection.

RS232C cable connect with RS232C2 of control unit 1(CSUX1CU-F1)

Control unit 1



Power code

Bright Field2 (BF2) cable

Bright Field 1(BF1) cable



**CAUTION**

Please ONLY use attached cables, otherwise, it is possible to fail EMC conformity.



### 3.3.3 Power On

(1) Control Unit

Please confirm if the controller Interlock key is inserted into

EXT INTERFACE1/I.LOCK at the backside of the control unit. If not, please insert supplied key. Also, please confirm if CSU-X1 and the control unit is connected with supplied cable. And then, put the power of the control unit ON.

(2) CSU-X1

Please switch on the CSU-X1 after the control unit is ON.

## 4 Name and Function

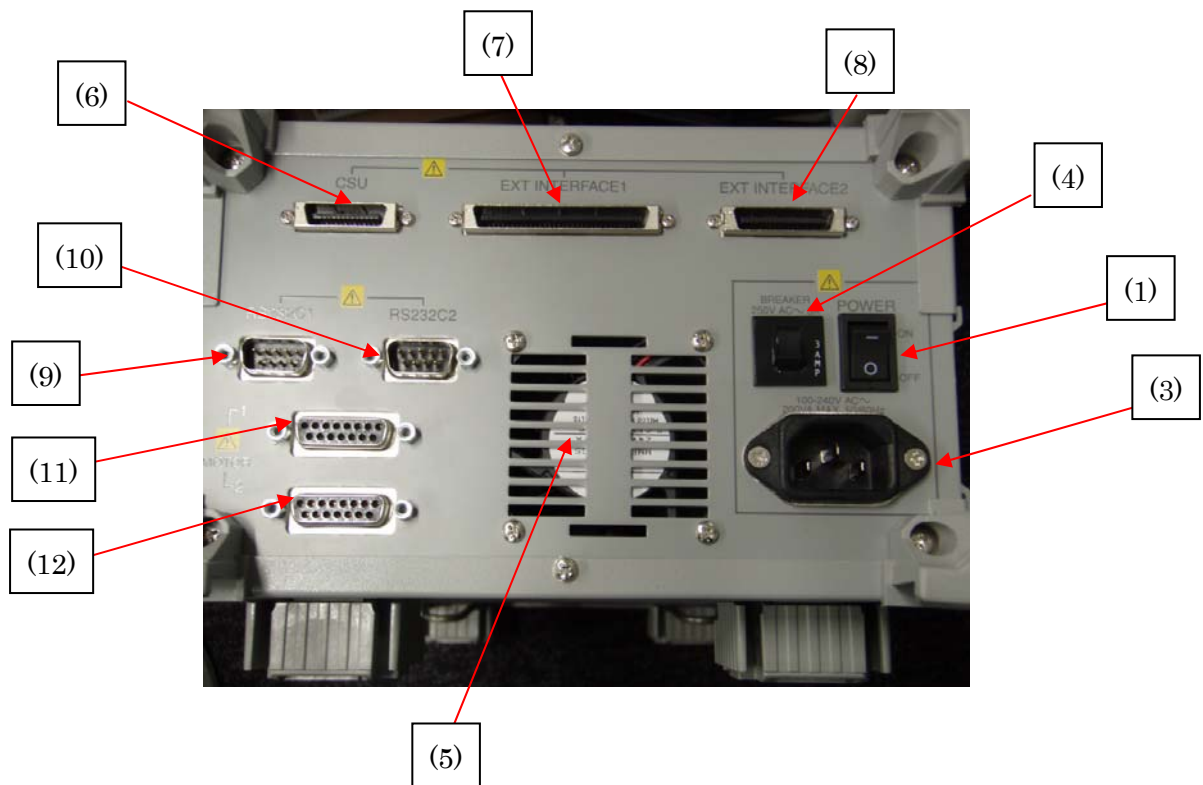

(1) Power Switch

(2) Power ON indicator

Green LED lights when power is ON. LED is off when power is OFF.

(3) AC Inlet

Socket for AC POWER. Please use supplied power cable.

(4) Circuit breaker: 3A

(5) Cooling fan

(6) CSU connector

To connect with CSU-X1 with supplied CSU connector cable.

(7) EXT INTERFACE1/I.LOCK connector

For controller interlock and external input/output connection

(8) EXT INTERFACE2 connector

For external analogue input/output connection

(9) RS232C1 connector

For serial interface CH1 connection using supplied RS232C cable. When you use one control unit, connect to PC, and connect to RS232C2 (CH2) if you use two control units. Please firmly connect with fixing screw.

(10) RS232C2 connector

For serial interface CH2 connection using supplied RS232C cable. It is not necessary when you use only one control. Connect to RS232C1 (CH1) of the second control unit if you use two control units. Please firmly connect with fixing screw.

(11) MOTOR1 connector

\*CSUX1CU-F1 model: Connector for Filter wheel 1, connected with supplied FW1 cable. Please firmly connect with fixing screw..

\*CSUX1CU-B1model: Connector for Bright Field1 connection, connected with supplied Bright Field1 cable. Please firmly connect with fixing screw.

(12) MOTOR2 connector

\*CSUX1CU-F1 model: Connector for FW1 connection, connected with supplied FW1 cable. Please firmly connect with fixing screw..

\*CSUX1CU-B1model: Connector for Bright Field2 connection, connected with supplied Bright Field2 cable. Please firmly connect with fixing screw.

(13) Identification label

MS code, rated supply voltage, product number and serial number

## 5 Maintenance

- Never use organic solvent to clean this instrument. Wipe off stains with clean cloths, and if necessary diluted detergent may be used to remove stubborn stains.
- Consult Yokogawa Electric Corporation, or your local representative, in the case of malfunction.

### 5.1 Circuit Breaker

#### (1) Position

Circuit breaker, instead of fuse, is installed at the following position.



Circuit breaker

#### (2) Function

Shut down if overloaded and becomes over current status. As shown below, reset button gets out and white indicator shows up.

White indicator

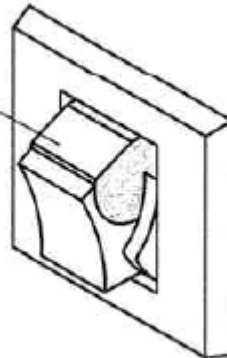

### (3) Resetting of circuit breaker

You can reset the circuit breaker by pushing the button one minute after shut down. However, if over current status still continues, top-free function works and you cannot reset.

### Caution

In case circuit breaker worked to shut down, there should be a problem in the circuit of this unit. If you cannot reset, please consult with your local representative. Do not repeat resetting many times.

## 6 Specification

### 6.1 Product Specification

#### 6.1.1 Control Unit

Item	Specification
Rotation speed control	<ul style="list-style-type: none"> <li>*Standard: 1500~5000rpm (Max.1000fps)</li> <li>* High Speed: 1500~10000rpm (Max.2000fps)</li> <li>* Possible for command control of rotation speed setting.</li> <li>* Rotation speed setting/reading resolution:               <ul style="list-style-type: none"> <li>1500~5000rpm: 1rpm</li> <li>5000~10000rpm: 2rpm</li> </ul> </li> <li>* External sync is possible by pulse signal input via external signal input terminal.</li> <li>* External output terminal can send 12 pulse per one rotation</li> </ul>
DM Exchange	Command control of exchanging up to 3 DM positions in the DM block
Shutter Control	Command control or external line control of shutter on/off
External I/O control	<ul style="list-style-type: none"> <li>*Digital I/O: TTL Input 4CH, Contact Input 4CH, Open Collector output 4CH, Contact output 4CH</li> <li>*External shutter control, synchronization control of CSU rotation speed, synchronization signal output, etc.</li> <li>*Analogue input: 8 ports, 0~5V, 8Bit (0~255), Response 100ms.</li> <li>*Analogue output: 4 ports, 0~5V, 8Bit (0~255), Response 10ms</li> </ul>
Filter Wheel control (CSU-X1CU-F1)	Command control of filter positions One control unit controls up to two filter wheels
Bright Field/ Camera port control (CSU-X1CU-B1)	Command control of light path switching (confocal/non-confocal) Switch between 1 <sup>st</sup> camera port and 2nd camera port
Interlock key	<ol style="list-style-type: none"> <li>1.Installed: Manual shutter switch becomes valid. External shutter control from PC through control unit becomes possible.</li> <li>2.Uninstalled: Shutter closes, motor stops and manual shutter switch becomes invalid</li> </ol>

Item	Specification
Communication	<p>1.Connection Connect control unit cable to the external interlock connector of CSU-X1 head Connect control unit and PC through RS232C serial cable Possible to connect and control two control units through daisy chain.</p> <p>1. Conditions * Speed: 115,200 bps * Data bit: 8 * Parity check: None * Stop bit : 1 * Line-feed character: CR * Separating character: colon or space ① * Case sensitivity: Yes</p>
Commands	Shown in the command list
Power consumption	Input: 100~240VAC±10%、50 or 60Hz、200VAmax
Accessory	<p>1. AC100VAC cable 2. Bright Field1connection cable (only for CSU-X1CU-B1) 3. Bright Field2connection cable(only for CSU-X1CU-B1) 4. CSU connection cable 5. RS232C cable (cross)</p> <p>1. 6. Interlock key for control unit</p>

### 6.1.2 Filter Wheel (Option)

Item	Specification
Installable filters	<ul style="list-style-type: none"> <li>* Size: <math>\phi 25\text{mm}</math>&gt;</li> <li>* Max. 6 filters</li> <li>* It is necessary to fill open position with a dummy disc for weight balance</li> </ul>
Exchange speed	<ul style="list-style-type: none"> <li>* 33msec to the adjacent position. It is necessary to wait for 33msec&lt; before moving to the next position</li> <li>* 66msec to move two positions. It is necessary to wait for 33msec&lt; before moving to the next position</li> <li>* 99msec to move three positions. It is necessary to wait for 33msec&lt; before moving to the next position.</li> <li>* Control unit makes the filter wheel move toward shortest direction.</li> </ul>
Accessories	<ul style="list-style-type: none"> <li>* 6 Aluminum disks (dummy filter) to balance weight</li> <li>* Special tool to screw/unscrew filter fixing rings</li> <li>* Connection cable</li> </ul>
Power supply	24V DC 3.7A Supplied from the control unit

### 6.1.3 Environment

Item	Specification
Environment	1. Operation temperature and humidity range 15~40°C, 20~75%RH. No condensation. 2. General environment -20~70 °C, 5~95%RH No condensation.*1
Dimensions	1. CSU-X1 Unit * CSU-X1-M1: 175(W)×328.5(H)×177.5(L) mm (w/o protruding parts) * CSU-X1-M2: 258.8(W)×373(H)×177.5(L) mm (Includes Bright Field, w/o protruding parts.) * CSU-X1-A1: 175(W)×328.5(H)×325.1(L) mm (Includes filter wheel, w/o protruding parts.) * CSU-X1-A2: 258.8(W)×373(H)×325.1(L) mm (Includes filter wheel and Bright Field, w/o protruding parts.) * CSU-X1-A3: 308.5(W)×328.5(H)×325.1(L) mm (Includes 2 <sup>nd</sup> camera port and filter wheel, w/o protruding parts.) 2. Control unit (CSU-X1CU) 213(W)×132(H)×438(L) mm (w/o protruding parts) 3. Filter wheel (CSU-X1FW) 112(W)×100(H)×226(L) mm (w/o protruding parts)
Weight	1. CSU-X1 Main unit: 5.5kg Camera port and filter block: 2.0kg Bright Field Unit: 2kg 2. Control unit (CSU-X1CU) 5.2kg 3. Filter wheel (CSU-X1FW) 1.9kg

\*1 Desirable environment for delivery, storage or whatever when the instrument is not in operation, under which the instrument may not suffer unrecoverable damages.



## 6.1.4 Conformity

CE marking:

EMC Directive : EN61326、 EN61000-3-2、 EN61000-3-3

Low Voltage Directive : EN61010-1

Measurement category (\*1)

Pollution Degree 2 (\*2)

- \*1: To measure circuit connected to low voltage units, applied on electrical instruments which has power supply from fixed power switchboard.
- \*2: Degree of adhesion of any solid, liquid or gas which may lower surface resistance or electric strength, applied to normal room atmosphere.

## 6.1.5 Global Environment Action

Lead free solder is used.

Lead free glass is used.

No use of Cr+6 for chromium plating

## 6.2 Model and Suffix Code (MS Code)

Basic specification code of control unit

Model	Basic Code	
<b>CSUX1CU</b>		
Main Unit	<b>-F1</b>	For Filter Wheel
	<b>-B1</b>	For Bright Field
Language of labels	<b>-J</b>	Japanese
	<b>-E</b>	English

Basic specification of Filter Wheel (Option)

Please refer to IM of CSUX1FW

## 6.3 Dimension of CSUX1CU

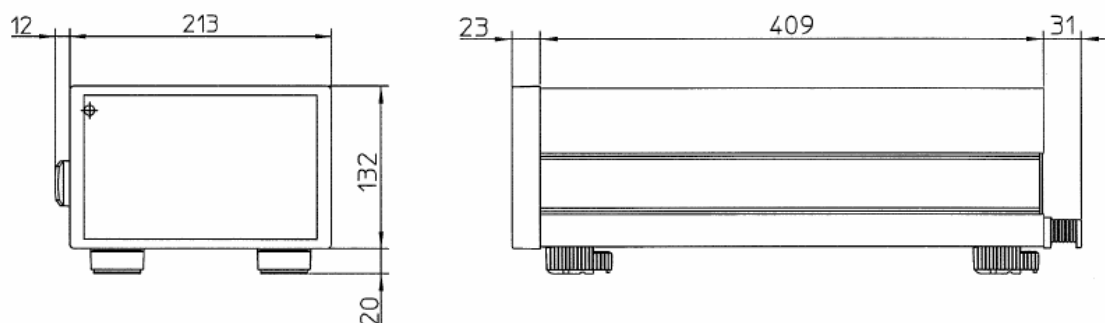

## 6.4 External Input/Output

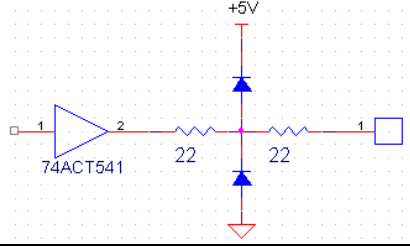

Table 6-4-1 PCR28 pin(male) connector

Pin No.	Signal	Function	I/O	Connection
1	Reserved			
2	Reserved			
3	SHUTTER*1	Shutter control input signal: High is Open; Low is Close	Input	TTL/CMOS level
4	Reserved			
5	Reserved			
6	Reserved			
7	SYNC	Sync trigger input signal	Input	TTL/CMOS level
8	INDEX	Sync trigger output signal Pulse width 10ms< 300Hz~2kHz	Output	TTL/CMOS level
9	Interlock	Open is interlock	Input	TTL/CMOS level
10	Reserved			
11	Reserved			
12	Reserved			
13	PORT	M6 port position signal	Output	TTL/CMOS level
14	Reserved			
15	Reserved			
16	Reserved			
17	Reserved			
18	Reserved			
19	Reserved			
20	Reserved			
21	SYNC-	GND		
22	INDEX-	GND		
23	Interlock-	GND		
24	Reserved			
25	Reserved			
26	Reserved			
27	PORT-	GND		
28	Reserved			

\*1 : Maximum allowable shutter on/off frequency is 3Hz for shutter protection. If you input faster frequency, shutter will not work properly.

Table6-4-2 PCR68pin (male) connector of control unit

Pin No.	Signal name	Function	I/O	Connection
1	TI1(EI1)*1	TTL input ch1	Input	TTL level 
2	TI2(EI2)*1	TTL input ch2	Input	
3	TI3(EI3)*1	TTL input ch3	Input	
4	TI4(EI4)*1	TTL input ch4	Input	
5	VCOM1	Source for contact input VCOM1	Input	For contact input source (DC5V) 
6	VCOM2	Source for contact input VCOM2	Input	
7	VCOM3	Source for contact input VCOM3	Input	
8	VCOM4	Source for contact input VCOM4	Input	
9	Interlock +	Open is interlock	Input	4Connect with 43pin
10	Reserved			
11	Reserved			
12	CSU_SYNC	CSU sync signal input 300Hz-2kHz “limitation exists in the rotation speed”	Input	TTL/CMOS level 
13	SHUTTER*5	External shutter control signal H:Open, L:Close	Input	
14	OC1(EO1)*2	Open collector output 1, H is ON	Output	DC5V 100mA max 
15	OC2(EO2)*2	Open collector output 2, H is ON	Output	
16	OC3(EO3)*2	Open collector output 3, H is ON	Output	
17	OC4(EO4)*2	Open collector output 4, H is ON	Output	
18	DO1+(EO5)* 3	Contact output 1+, H is ON	Output	DC30V 500mA max 
19	DO2+(EO6)* 3	Contact output 2+, H is ON	Output	
20	DO3+(EO7)* 3	Contact output 3+, H is ON	Output	
21	DO4+(EO8)* 3	Contact output 4+, H is ON	Output	
22	Reserved			
23	Reserved			
24	Reserved			
25	Reserved			

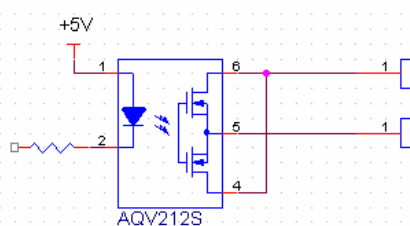
26	Reserved			
27	CSU_INDEX	CSU rotation sync signal 300-2kHz	Output	TTL level 
28-31	Reserved			
32-34	5V	DC5V	Output	100mA max
35	GND	GND		
36	GND			
37	GND			
38	GND			
39	DI1(EI5)*4	Photo-coupler input 1	Input	DC5V 7~20mA 
40	DI2(EI6)*4	Photo-coupler input 2	Input	
41	DI3(EI7)*4	Photo-coupler input 3	Input	
42	DI4(EI8)*4	Photo-coupler input 4	Input	
43	Interlock-	Interlock	Input	Connect with 9 pin
44	GND			
45	GND			
46	GND			
47	GND			
48	GND			
49	GND			
50	GND			
51	GND			
52	DO1-	Contact output 1-	Output	DC30V 500mA max 
53	DO2-	Contact output 2-	Output	
54	DO3-	Contact output 3-	Output	
55	DO4-	Contact output 4-	Output	
56-68	GND			

\*1: Possible to acquire input terminal ch1-ch4 levels: EI,[ch],?

\*2: Possible to assign output terminal ch1-ch4 levels: EO,[ch],[n]

\*3: Possible to assign output terminal ch5-ch8 levels: EO,[ch],[n]

\*4: Possible to acquire input terminal ch5-ch8 levels: EI,[ch],?



WARNING



CAUTION

\*5:

Please control shutter ON/OFF below 3Hz. Faster ON/OFF control may damage the shutter. Shutter may not work properly above 3Hz.

Please do not open the dichroic mirror block cover when you input shutter control signal. If you do so, shutter closing timing could delay and laser beam may leak out

Table 6-4-3 PCR36 pin (male) connector

Pin No.	Signal Name	Function	I/O	Connection
1	AD1 *1	Analogue input 1CH	Input	Resolution 0-5V 10bit Precision 8bit 
2	AD2 *1	Analogue input 2CH	Input	
3	AD3 *1	Analogue input 3CH	Input	
4	AD4 *1	Analogue input 4CH	Input	
5	AD5 *1	Analogue input 5CH	Input	
6	AD6 *1	Analogue input 6CH	Input	
7	AD7 *1	Analogue input 7CH	Input	
8	AD8 *1	Analogue input 8CH	Input	
9	DA1 *2	Analogue output 1CH	Output	Resolution 0-5V 12bit Precision 8bit 
10	DA2 *2	Analogue output 2CH	Output	
11	DA3 *2	Analogue output 3CH	Output	
12	DA4 *2	Analogue output 4CH	Output	
13	NC	Unconnected		
14	NC	Unconnected		
15	NC	Unconnected		
16	NC	Unconnected		
17	NC	Unconnected		
18	Reserved			
19-30	GNDA	Analogue GND		
31-35	NC	Unconnected		
36	GNDA	Analogue GND		

\*1 : Possible to acquire AD ch1-ch8 data: AD\_DATA,[ch],?

\*2: Possible to assign AD ch1-ch8 output value: DA\_DATA,[ch],[n]

Table 6-4-4 RS232C1 D-Sub9 pin connector

Pin No.	Signal Name	Function	I/O	Connection
1	NC	Unconnected		
2	RXD		Input	RS232C compliant
3	TXD		Output	RS232C compliant
4	NC	Unconnected		
5	GND			
6	NC	Unconnected		
7		Short circuit with pin 8		
8		Short circuit with pin 7		
9	NC	Unconnected		

Table 6-4-5 RS232C2 D-Sub9 pin connector

Pin No.	Signal Name	Function	I/O	Connection
1	NC	Unconnected		
2	RXD		Input	RS232C compliant
3	TXD		Output	RS232C compliant
4	NC	Unconnected		
5	GND			
6	NC	Unconnected		
7		Short circuit with pin 8		
8		Short circuit with pin 7		
9	NC	Unconnected		

Table 6-4-6 MOTOR1 D-Sub15 pin connector of control unit 1 (CSUX1CU-F1)

Pin No.	Function	I/O	Connection
1	MOTOR1 output	Output	
2	MOTOR1 output	Output	
3	MOTOR1 output	Output	
4	MOTOR1 output	Output	
5	MOTOR1 output	Output	
6	MOTOR1 output	Output	
7	MOTOR1 output	Output	
8	MOTOR1 output	Output	
9	Unconnected		
10	Unconnected		
11	Sencer input	Input	
12	Unconnected		
13	Unconnected		
14	Source for sensor (24V)		
15	GND for sensor		

Table 6-4-7 MOTOR2 D-Sub15 pin connector of control unit 1 CSUX1CU-F1)

Pin No.	Function	I/O	Connection
1	MOTOR2 output	Output	
2	MOTOR2 output	Output	
3	MOTOR2 output	Output	
4	MOTOR2 output	Output	
5	MOTOR2 output	Output	
6	MOTOR2 output	Output	
7	MOTOR2 output	Output	
8	MOTOR2 output	Output	
9	Unconnected		
10	Unconnected		
11	Sensor input	Input	
12	Unconnected		
13	Unconnected		
14	Source for sensor (24V)		
15	GND for sensor		

Table 6-4-8 MOTOR1 D-Sub15 pin connector of control unit 2 (CSUX1CU-B1)

Pin No.	Function	I/O	Connection
1	Unconnected		
2	Unconnected		
3	Unconnected		
4	Unconnected		
5	Unconnected		
6	Unconnected		
7	Unconnected		
8	MOTOR1output	Output	
9	MOTOR1output	Output	
10	MOTOR1output	Output	
11	Sensor input	Input	
12	MOTOR1output	Output	
13	MOTOR1output	Output	
14	Source for sensor		
15	GND for sensor		



Table 6-4-9 MOTOR2 D-Sub15 pin connector of control unit 2 (CSUX1CU-B1)

Pin No.	Function	I/O	Connection
1	Unconnected		
2	Unconnected		
3	Unconnected		
4	Unconnected		
5	Unconnected		
6	Unconnected		
7	Unconnected		
8	MOTOR1output	Output	
9	MOTOR1output	Output	
10	MOTOR1output	Output	
11	Sensor input	Input	
12	MOTOR1output	Output	
13	MOTOR1output	Output	
14	Source for sensor(24V)		
15	GND for sensor		

## 6.5 Command List

Table 6-5-1 Command List

Main Item	Detailed item	Function	Command	
CSU control	Shutter	Open shutter	SHO	
		Close shutter	SHC	
		Acquire shutter status	SH, ?	
		Acquire open/close count	SH_CNT, ?	
	Disk	Assign disk rotation speed [rpm]	MS, [n]	
		Fine adjustment of disk rotation speed to increase	MS+	
		Fine adjustment of disk rotation speed to decrease	MS-	
		Acquire disk rotation speed [rpm]	MS, ?	
		Acquire upper limit of disk rotation speed [rpm]	MS_MAX, ?	
		Automatic adjustment to camera exposure time [ms]	MS_ADJUST, [f]	
		Run disk rotation	MS_RUN	
		Stop disk rotation	MS_STOP	
		Dichroic mirror	Assign dichroic mirror position	DM_POS, [n]
			Acquire dichroic mirror position	DM_POS, ?
Filter Wheel control	Assign Filter Wheel position	FW_POS, [ch], [n]		
	Acquire Filter Wheel position	FW_POS, [ch], ?		
Bright Field control ( Port switching control)	Bright Field	Move Bright Field port to the original point	BF_INIT	
		Switch port to confocal position	BF_OFF	
		Switch port to Bright Field position	BF_ON	
	Port	Acquire current position	BF_POS, ?	
		Assign Port position	PT_POS, [ch], [n]	
		Acquire Port position	PT_POS, [ch], ?	
External IO control	General purpose IO	Assign output terminal level	EO, [ch], [n]	
		Acquire appointed level of output terminal	EO, [ch], ?	
		Acquire input terminal level	EI, [ch], ?	
	General purpose DA	Set DA output parameter	DA_DATA, [ch], [n]	
	General purpose DA	Set DA output parameter	DA_DATA, [ch], [n]	
	General purpose AD	Acquire AD input value	AD_DATA, [ch], ?	
	Memory control	Save memory	Save parameters	SAVE_MEM
Save Filter Wheel information (max.16 letters)			FW_INFO, [ch], [n] "XXX X"	
Save dichroic mirror information (max. 16 letters)			DM_INFO, [n], "XXXX"	
Memory load		Load parameters from memory	L_LOAD_MEM	
	Load default parameter	LOAD_INIT		

		Acquire Filter Wheel information	FW_INFO, [ch], [n], ?
		Acquire dichroic mirror information	DM_INFO, [ch], ?
Hardware information	CSU Information	Acquire serial number of CSU	SERIAL_CSU, ?
		Acquire product ID of CSU	PRODUCT_CSU, ?
	Error information	Acquire error ID	ERRID, ?
	Connection status	Acquire hardware connections	SYSTEM, ?
	Software information	Acquire software version	VER, ?
		Acquire build time of software	BULIDTIME, ?
	Hardware misc.	Output error ID log	LOG_ON
		Not to output error ID log	LOG_OFF
		Acquire connection status of own control unit	SYSTEM_THIS, ?
		Acquire connection status of extension control unit	SYSTEM_EXT, ?

#### Command notation

- \* colon or (space) : delimiter
- \* [ch] : channel number of connected instruments
- \* [n] : integral number parameter
- \* [f] : decimal number parameter
- \* "xxxx" : letter string parameter

## 7 Warranty

- The term of warranty is for one year after the day of purchase. Yokogawa Electric Corporation will repair the Product at no charge during the term of warranty.
- The warranty covers this instrument only.
- Yokogawa Electric Corporation cannot be held liable for damages resulting from operating errors, improper use, handling or storage, unauthorized repair or modification of the Product by the customer, transportation, fire, natural disasters (such as earthquake, flood, thunderbolt, etc.), salt damages, corrosive gas damages, or abnormal voltage, moving or dropping the Product after delivery, or any other damages for which Yokogawa Electric Corporation is not responsible.
- Please contact either Yokogawa Electric Corporation or your representative if you want to request for repair.

Contact:

Yokogawa Electric Corporation,  
Life Science Business Headquarters,  
Bio Center

E-Mail: [csu@csv.yokogawa.co.jp](mailto:csu@csv.yokogawa.co.jp)

Tel: 81-(0) 76-258-7028

Fax: 81-(0) 76-258-7029

---

**User's  
Manual**

**Filter Wheel—CSUX1FW**

**IM 85A7C27-01E**

---



## Table of contents

1	Safety Precautions .....	3
1.1	Introduction.....	3
1.2	Caution .....	3
1.3	History.....	3
1.4	General Safety Precautions.....	4
2	Product Overview.....	7
2.1	Product overview.....	7
3	Before Using the Unit.....	8
3.1	Packing List .....	8
3.2	Before Use .....	9
3.2.1	Safety Precautions.....	9
3.2.2	General precautions on handling.....	9
3.3	Installation.....	10
3.3.1	Installation requirements.....	10
3.3.2	Connection of equipment.....	11
3.3.3	Application of Power.....	13
4	Name and function.....	14
5	Maintenance.....	17
5.1	Filter exchange.....	17
6	Specification .....	19
6.1	Specification .....	19
6.1.1	Specification of filter wheel .....	19
6.1.2	Environment .....	19
6.1.3	Conformity .....	20
6.1.4	Global Environment Action.....	20
6.2	Model and Suffix Code (MS Code).....	21
6.3	Dimension of CSUX1FW .....	22
6.4	Control Signal .....	23
7	Warranty .....	24





# 1 Safety Precautions

## 1.1 Introduction

Thank you so much for purchasing the CSUX1FW: Filter Wheel for CSU.

This manual covers the features, operation methods and procedures, safety and handling precautions of the CSUX1FW.

Before you start to use the unit, read this manual thoroughly and operate the unit in a proper manner.

After read the annual through, keep the manual in a safe place for future quick reference.

## 1.2 Caution

- No part of the user's manuals may be transferred or reproduced without prior written consent from YOKOGAWA.
- YOKOGAWA continues to improve the product's performance and features, and for this reason, the specifications and information herein are subject to change at any time and without notice.
- The authors and publishers of this manual have used their best efforts in preparing this document, but make no representation or warranties with respect to the accuracy, applicability, fitness, or completeness of the contents of this manual. If you have noticed any problems or have any suggestions for the manual, please contact us.
- To maintain long-term, stable performance of the product, observe the operation instructions in this manual.

## 1.3 History

1<sup>st</sup> Edition: August, 2007

-

## 1.4 General Safety Precautions

For the protection and safe use of this instrument, be sure to follow the instructions on safety described in this manual when handling this instrument. If you use the instrument in a manner not specified in this manual, the protection provided by this instrument may be impaired. In addition, Yokogawa Electric Corporation assumes no liability for the customer's failure to comply with these requirements.

The following symbols are used on the instrument:

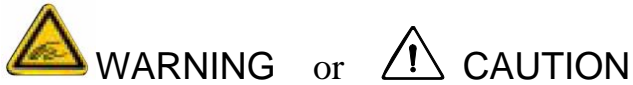

Both of the above two symbols indicate that important content is mentioned. The symbols are given wherever you are required to refer to the manual in order to avoid personal injury and/or damage to the instrument.

The following symbols are used in this manual.



This symbol indicates that the operator must refer to an explanation in the user's manual in order to avoid injury or death of personnel and/or damage to the instrument.



The symbol indicates that the operator must refer to an explanation in the user's manual in order to avoid minor injury and/or damage to the instrument.

To reduce the risk of bodily injury or of personnel and/or damage to the instrument, observe the following precautions:



## WARNING

- **Power supply**  
Ensure the source voltage matches the voltage of the power supply before turning on the power.
- **Power strip and plug**  
Avoid electric shock and fire disaster, please use a power strip that provided by YOKOGAWA. Connect the main power supply plug with power receptacle that comprise a protective earth terminal. If you use extension code without protective earth terminal, protected operation is invalid.
- **Protective earth**  
Avoid electrical shock , ensure the protective earth before turning on the power. The power supply code attached the CSUX1FW is tripolar power strip with earthing conductor, thus please use tripolar power receptacle with protective earth terminal. If you use an adapter that exchangeable between tripolar and bipolar, ensure the protective earth terminal connected with earthing conductor of the conversion adapter.
- **Necessity of the protective earth**  
Avoid mechanical failure, never cut off internal and external of protective earth conductor and unfix the wire connection of the protective earth terminal.
- **Defection of protective function**  
Never apply the CSUX1FW, when defection of protective function such as protective earth and fuse appear. Ensure the protective function before using the CSUX1FW.
- **Use under gas**  
It is extremely dangerous to use this instrument under the atmosphere with explosive or evaporating gas, or vapor.
- **Disassemble the case**  
There are high-voltage place internal of the CSUX1FW, never disassemble the case except the service personnel.
- **External connection**  
Ensure the protective earth before connect with referent hardware.



## CAUTION

- The CSUX1FW is used in combination with CSU-X1 confocal scanner unit, CSU control unit, laser system, microscope, and cameras, to be purchased separately. In addition to this manual, read carefully the user's manual of the respective products and follow their instructions.
- To avoid damage to the CSUX1FW, make sure that input and output terminals satisfy the specifications.
- The CSUX1FW is high-precision optical product. Do not install or use the CSUX1FW in areas with excessive vibration, excessive or conductive dust, high humidity, excessive heat (near heat sources or in direct sunlight), sudden temperature change ( that may cause condensation), corrosive or flammable gas, etc.
- Do not touch any parts inside the CSUX1FW. Any dust, soil or minor damage on the optical parts inside the CSUX1FW may result in damages.
- In case of a mechanical trouble in the CSUX1FW, never touch inside the instrument, and contact Yokogawa Electric Corporation or its representative.

## • 2 Product Overview

### 2.1 Product overview

The CSUX1FW is a high speed filter wheel to be used in combination with the confocal scanner, model CSU-X1. The Control unit, CSUX1CU-FI (optional) is necessary to use the CSUX1FW.

One CSU control unit (CSUX1CU-F1) can control up to two units of CSUX1FW



Two units of CSUX1FW mounted to CSUX1-A3 (Second Camera Model)



### 3 Before Using the Unit

#### 3.1 Packing List

Filter Wheel (CSUX1FW)

Supplied with CSUX1-A1,-A2,-A3,or CSUX1-M1N,-M1H,-M2N,-M2H

Part name	Part number	QTY	Description
Filter wheel	M3918MA	1	Filter wheel
Aluminum disc for weight balance	M3916MW	6	Aluminum disc to fill open positions in the filter wheel for weight balance
Connection cable 1 *1	M3918AP	1	Connection cable for filter wheel 1 2.5m shield cable
Connection cable 2 *1	M3918AQ	1	Connection cable for filter wheel 2 2.5m shield cable
Filter Wrench	M3916CX	1	Tool for exchanging filters in the filter wheel

\*1: Connection cable 1 is supplied with CSUX1FW-06P-01, and Connection cable 2 is supplied with CSUX1FW-06P-02



#### CAUTION

- You have to use attached cables ONLY, otherwise, it is possible to fail EMC conformity.

## 3.2 Before Use

### 3.2.1 Safety Precautions

- Before you start to use the unit, please read this manual thoroughly
- Do not remove the cover to avoid risk of burn injury, since some parts inside the unit could become high temperature. Please contact Yokogawa Electric Corporation or its representative, when you need inspection or adjustment of the CSUX1FW.
- In case of such abnormal status as unusual odor or smoke goes up from the CSUX1FW, turn off the power switch of the controller and contact Yokogawa Electric Corporation or its representative.
- Do not put any objects on the cable. Do not let the cable touch heating objects. When you disconnect the cable, do not pull the cable but always pull the connector. In case a cable was damaged, please contact your local representative for replacement order. You may find necessary parts number in the packing list of this manual.

### 3.2.2 General precautions on handling

- Please do not place any liquid-containing objects on this unit, since liquid spilling could damage the unit.
- Be careful not to add mechanical shock or drop the unit, which could result in severe damage. Application of mechanical shock to the cable could cause electric noise which may lead to malfunction..
- Avoid bringing any charged object close to the terminal, which may cause failure.
- Please be most careful when you carry this unit. Remove the connecting cable first, then, use the handle on this unit to carry. This unit weighs about 2kg.
- Please do not wipe the plastic surface with organic solvents such as benzene or paint thinner, which may cause discoloration. When the surface of the unit gets dirty, please clean with soft cloth wet with dilute solvent, and then wipe with a dry cloth.

## 3.3 Installation

### 3.3.1 Installation requirements

Please use this unit under the following environment.

Ambient air temperature: 15~40□

Ambient humidity: 20~75%RH (No dew condensation.)



#### CAUTION

- Dew formation inside the unit may occur when you move the unit between much different temperature/humidity environments. In such case, please wait for an hour or more until condensation resolved before use.

<Ventilation>

Please be careful to secure enough space around the ventilation hole of the unit placed at the motor cover to avoid overheating.,



#### CAUTION

Please do not install the unit under the following conditions.

- Under direct sunlight
- Close to heating objects
- Polluted with oily smoke, steam, dusts or corrosive gas
- Close to any objects with heavy electromagnetic field
- Close to high-voltage apparatus or a power line
- Under heavy mechanical vibration
- Unstable place

<Installation>

Please install the unit as shown below.





### 3.3.2 Connection of equipment

#### Connection with the controller

Connect MOTOR1 connector and Filter Wheel 1 with supplied Filter wheel 1 (FW1) connecting cable.

- If necessary, connect MOTOR2 connector of Filter Wheel 2 with supplied Filter Wheel 2 (FW2) connecting cable.
- Connect CSU connector of the control unit (CSUX1CU-F1) and the EXT CONTROL /INTERLOCK connector of CSUX1 with the supplied cable.

Connect the controller interlock key to the EXT INTERFACE1 / I.LOCK .

Connects the RS232C1 connector and PC with supplied RS232C cable.

After checking the power switch is OFF, connect the power cable

Please use the power receptacle which fulfills the following conditions.

- \* 3 pole electric socket equipped with protective earth terminal.
- \* Rated supply voltage: 100~240VAC
- \* Power voltage frequency range: 90~264VAC
- \* Rated supply frequency: 50~60Hz
- \* Power frequency latitude: 48~63Hz
- \* Maximum electric power consumption: 200VA

Please follow the warnings and cautions below before connecting the power supply of a controller. If these warning and cautions were not followed, there is a possibility of causing an electric shock or breakage of apparatus.



#### WARNING

- Please confirm your power supply is suitable for the rated supply voltage of this unit before connection.
- Please confirm before connecting the power cord if the power switch of this unit is off.
- Please ONLY use supplied power code to prevent electrical shock or fire.
- Please be sure to ground the protective earth for electric shock prevention.
- Please always use 3-prong plug with protective earth terminal to avoid risk of electrification.
- Please do not use the extension code without a protective earth conductor. Use of such will cancel out protection.

CSU control cable  
(ferrite core at this side).

Interlock key

PC COM port

RS232C cable

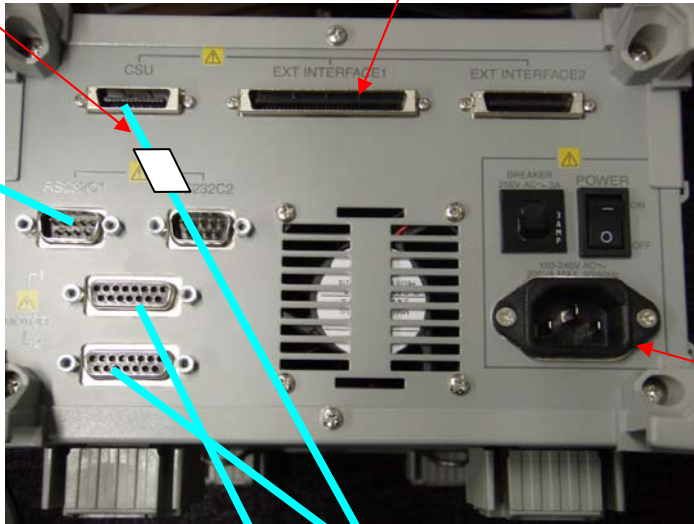

Power cable

Filter Wheel 2(FW2) cable

Filter Wheel 1(FW1) cable



### CAUTION

Please ONLY use attached cables, otherwise, it is possible to fail EMC conformity.

### 3.3.3 Application of Power

- Application of power on the controller

When you connect the CSUX1FW with a CSU-X1, confirm if the interlock key is connected to EXT INTERFACE1/I.LOCK at the back of a controller, and if not, please connect the interlock key. After checking the CSUX1 and the controller is connected with the connection cable, turn on the controller power.

- Application of power on the CSUX1: Release of the interlock

Please turn on power switch of the controller (CSUX1CU-F1) first, then, turn on the CSU-X1 power.



#### WARNING

Never inset your fingers in the open ports of filter wheel. You could injure fingers if the wheel moves.



#### CAUTION

There is a limitation in the operation interval of this filter wheel. If moved too fast, there could be malfunction. Please refer to the specification list in this manual.

## 4 Name and function

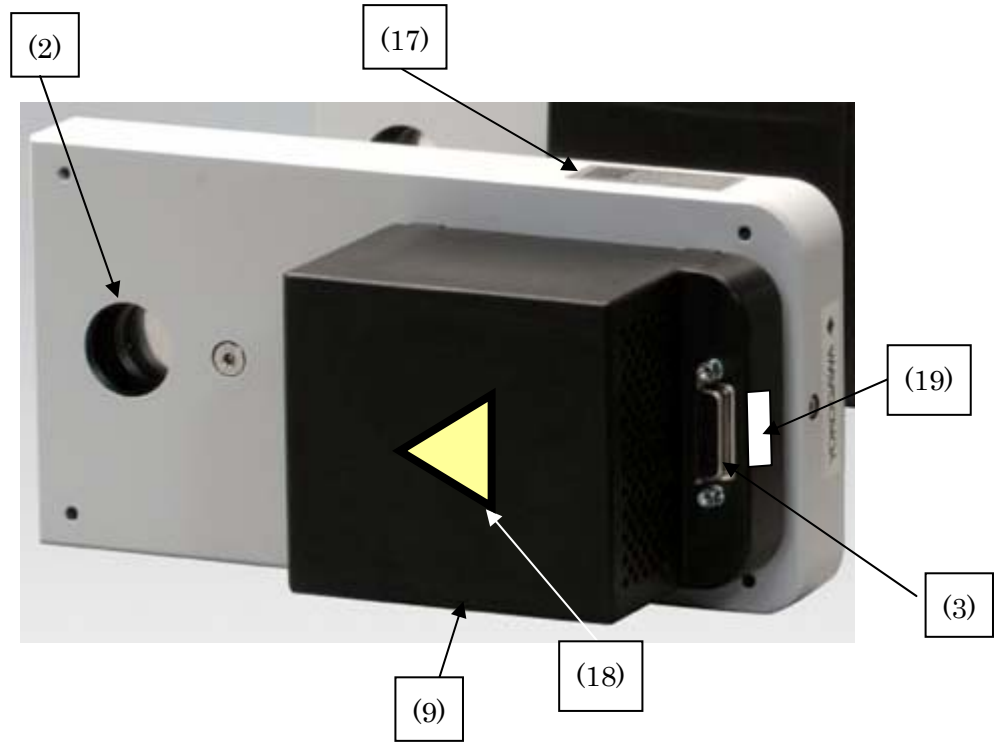

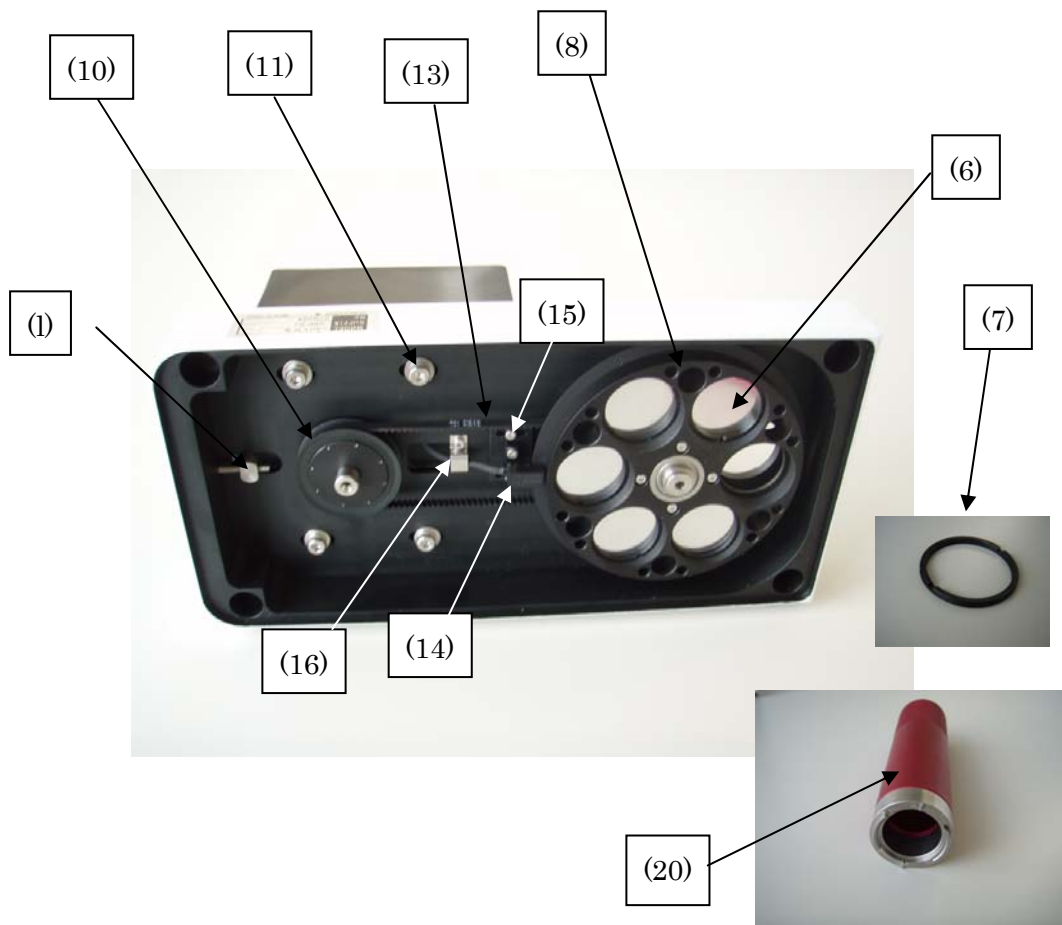

- 1) Incident light path window  
Do not put your fingers into this window when turn on the power supply and filter wheel is under operation. You could injure your fingers.
- 2) Outgoing light path window  
Do not put your fingers into this window when turn on the power supply and filter wheel is under operation. You could injure your fingers.
- 3) Connector for MOTOR cable  
Connect with the supplied MOTOR connecting cable. Please connect MOTOR1 connecting cable to the 1st filter wheel, and MOTOR2 connecting cable to the 2nd filter wheel.
- 4) Filter wheel cover  
Please open when exchanging filters. Make sure to put off power when you exchange filters.
- 5) Filter cover fixing screw  
Four screws to fix the cover.
- 6) Filter ports
- 7) Filter fixing ring  
Can be tightly screwed by using supplied screwing tool (20).

8). 6 ports filter table

Filter location numbers (from 1 to 6) are printed on the outer plate. Please set supplied aluminum discs into any open ports for weight balance.

9) Motor cover

Do not remove this cover to avoid burn injury since surface of the motor could become hot under operation.

10) Motor side pulley

11) Motor fixing screws

Never loosen these screws, otherwise, motor may fail normal function.

12) Belt adjustment screw

Please do not touch these screws.

13) Belt

14) Photo-sensor

15) Photo-sensor fixing screw

Do not loosen these screws, otherwise, photo-sensor may not work properly.

16) Photo-sensor cable fixing bracket

Please do not remove this bracket, otherwise, cable and belt may touch and cause damages.

17) Name plate to show below

\*Model code

\* Rated supply voltage

\* Product number

\* Serial number

18) Warning label

Warning label to indicate the operator must not insert fingers into the filter wheel ports under operation.



**WARNING**

Never inset your fingers into the open ports of filter wheel. You could injure fingers if the wheel moves

19) Identification label

To identify filter wheels 1 and 2.

20) Ring screwing tool

Special tool to screw/unscrew filter fixing ring, used when exchanging filters.

## 5 Maintenance

- Please do not use organic solvents for cleaning painted surface of this product. Please use soft cloth for cleaning.
- Do not touch inside the unit in case of failure, and please contact your local representative for repair.

### 5.1 Filter exchange

#### (1) Filter exchange

Set the notch of screwing tool (t) at the notch of filter fixing ring, turn counterclockwise to loosen and remove the ring.



The notch on the tool matches with the notch on the ring.

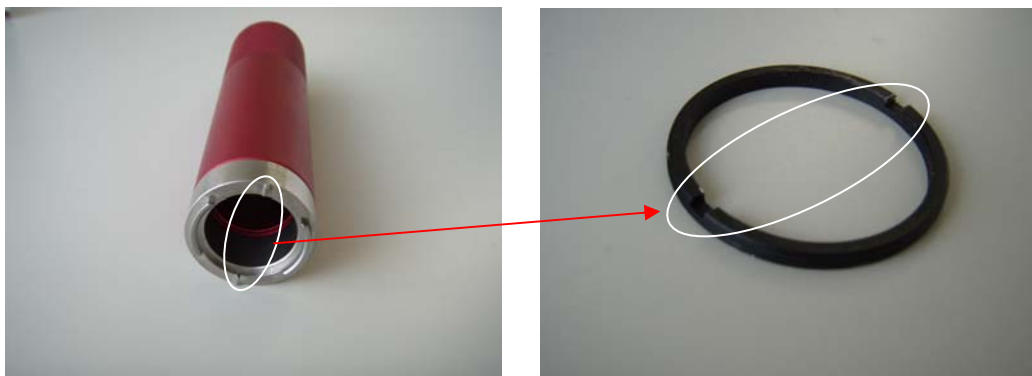



## WARNING

Please make sure to turn off power when you exchange filters. Otherwise, you may get injured when the filter wheel moves.



## CAUTION

Please fill all empty ports with supplied aluminum discs (one disc at one port) for weight balance. Otherwise, filter wheel may fail normal function.

“Aluminum disc”





## 6 Specification

### 6.1 Specification

#### 6.1.1 Specification of filter wheel

Item	Specification
Installable filters	<ul style="list-style-type: none"> <li>* Size: <math>\phi 25\text{mm}</math>&gt;</li> <li>* Max. 6 filters</li> <li>* It is necessary to fill all open positions with dummy discs to keep weight balance</li> </ul>
Exchange speed	<ul style="list-style-type: none"> <li>* 33msec to the adjacent position. It is necessary to wait for 33msec&lt; before moving to the next position</li> <li>* 66msec to move two positions. It is necessary to wait for 33msec&lt; before moving to the next position</li> <li>* 99msec to move three positions. It is necessary to wait for 33msec&lt; before moving to the next position.</li> <li>* Control unit makes the filter wheel move toward shortest direction.</li> </ul>
Accessories	<ul style="list-style-type: none"> <li>* 6 Aluminum disks (dummy filter) to balance weight</li> <li>* Special tool to screw/unscrew filter fixing rings</li> <li>* Connection cable</li> </ul>
Power supply	24V DC 3.7A Supplied from the control unit

#### 6.1.2 Environment

Item	Specification
Environment	1.Operation temperature and relative humidity range 15~40°C 20~75%RH No condensation. 2. General Environment -20~70°C 5~95%RH No condensation.*1
Dimensions	112(W) X 100(H) X 226(L) :excluding edged attachments
Weight	1.9Kg

\*1 Desirable environment for delivery, storage or whatever when the instrument is not in operation, under which the instrument may not suffer unrecoverable damages.

### 6.1.3 Conformity

CE marking:

EMC Directive : EN61326、 EN61000-3-2、 EN61000-3-3

Low Voltage Directive : EN61010-1

Measurement category (\*1)

Pollution Degree 2 (\*2)

- \*1 To measure circuit connected to low voltage units, applied on electrical instruments which has power supply from fixed power switchboard.
- \*2 Degree of adhesion of any solid, liquid or gas which may lower surface resistance or electric strength, applied to normal room atmosphere.

### 6.1.4 Global Environment Action

Lead free solder is used.

Lead free glass is used.

## 6.2 Model and Suffix Code (MS Code)

### CSUX1 Basic Specification (Optional)

Please refer to Installation Manual for the CSUX1

### Control unit Basic Specification (Optional)

Please refer to Installation Manual for the CSUX1CU

### Basic Specification of Filter Wheel

Model	Basic Codes	
<b>CSUX1FW</b>		
Filter position	<b>-06P</b>	6 Positions
Channel No.	<b>-01</b>	First Camera Port
	<b>-02</b>	Second Camera Port

Please select filters enlisted below:

When you order filters, please indicate filter position by numbers 1 to 6, and be careful not to select same numbers which means duplicate position..

Suffix Code	Laser nm,	Dye Examples
	<b>/B#100</b> 405nm	DAPI
Barrier Filter	<b>/B#101</b> 440-445nm	ECFP
(BA)	<b>/B#102</b> 473-491nm(for Solid laser)	EGFP, FITC
	<b>/B#103</b> 473-496nm(for ArKr laser)	EGFP, FITC
	<b>/B#104</b> 505nm, 514nm	EYFP
	<b>/B#105</b> 532nm	TRITC
	<b>/B#106</b> 561nm, 568nm	DsRed, mRFP
	<b>/B#107</b> 635-647nm	Cy5

### 6.3 Dimension of CSUX1FW

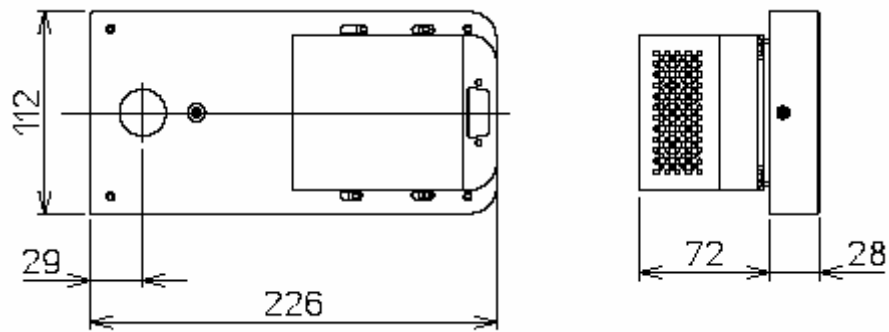

## 6.4 Control Signal

Table 6-4-1 D-Sub15 pin connector for filter wheel

Pin No.	Function	I/O	Connection
1	MOTOR1 input	input	
2	MOTOR1 input	input	
3	MOTOR1 input	input	
4	MOTOR1 input	input	
5	MOTOR1 input	input	
6	MOTOR1 input	input	
7	MOTOR1 input	input	
8	MOTOR1 input	input	
9	Unconnected		
10	Unconnected		
11	Sensor input	Output	
12	Unconnected		
13	Unconnected		
14	Source for sensor(24V)		
15	GND for sensor		

## 7 Warranty

- The term of warranty is for one year after the day of purchase. Yokogawa Electric Corporation will repair the Product at no charge during the term of warranty.
- The warranty covers this instrument only.
- Yokogawa Electric Corporation cannot be held liable for damages resulting from operating errors, improper use, handling or storage, unauthorized repair or modification of the Product by the customer, transportation, fire, natural disasters (such as earthquake, flood, thunderbolt, etc.), salt damages, corrosive gas damages, or abnormal voltage, moving or dropping the Product after delivery, or any other damages for which Yokogawa Electric Corporation is not responsible.
- Please contact either Yokogawa Electric Corporation or your representative if you want to request for repair.

Contact:

Yokogawa Electric Corporation,  
Life Science Business Headquarters,  
Bio Center

E-Mail: [csu@csv.yokogawa.co.jp](mailto:csu@csv.yokogawa.co.jp)

Tel: 81-(0) 76-258-7028

Fax: 81-(0) 76-258-7029