

AC/DC CLAMP METER

USER'S MANUAL

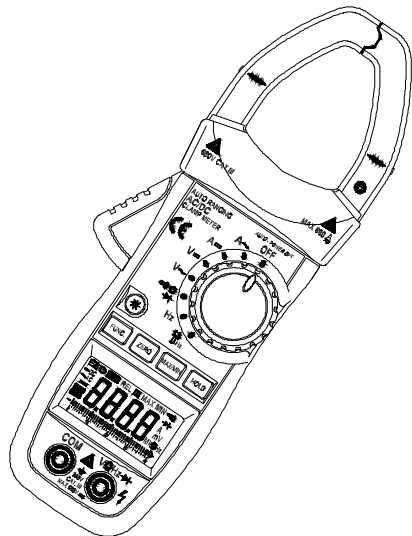

| CONTENTS | PAGE |
|--------------------------------|------|
| 1. SAFETY INFORMATION..... | 1 |
| 2. SYMBOL EXPLANATION | 1 |
| 3. SAFETY PRECAUTIONS..... | 2 |
| 4. MAINTENANCE..... | 3 |
| 5. GENERAL DESCRIPTION..... | 3 |
| 6. PANEL DESCRIPTION..... | 4 |
| 7. FORWARD LAYOUT..... | 6 |
| 8. OPERATING INSTRUCTIONS..... | 7 |
| 9. SPECIFICATIONS..... | 10 |
| 10. AUTO POWER OFF..... | 13 |
| 11. REPLACING THE BATTERY..... | 13 |
| 12. ACCESSORIES..... | 14 |

1. SAFETY INFORMATION

The digital clamp meter has been designed according to IEC1010 – 1 and IEC1010 – 2 – 032 concerning safety requirements for electrical measuring instruments and hand-held current clamps with double insulation overvoltage category 1000V CAT II 600V CAT III and pollution 2.

This meter complies with the requirements of the following European Community Directives:





89 / 336 / EEC (Electromagnetic Compatibility) and 73 / 23 / EEC (Low Voltage) as amended by 93 / 68 / EEC (CE Marking).

However, electrical noise or intense electromagnetic fields in the vicinity of the equipment may disturb the measurement circuit.

Measuring instruments will also respond to unwanted signals that may be present within the measurement circuit.

Users should exercise care and take appropriate precautions to avoid misleading.

2. SYMBOL EXPLANATION

-  Important safety information, refer to the operating manual.
-  Dangerous voltage may be present.
-  Earth ground.
-  Double insulation (Protection class 1000V CAT II 600V CAT III).

3. SAFETY PRECAUTIONS

Follow all safety and operating instructions to ensure maximum personal safety during the operation and to ensure the meter is used safely and is kept in good operating condition.

- Read the operating instructions thoroughly and completely before operating your meter.
- Pay attention to WARNINGS, which will inform you of potentially dangerous procedures. The instructions in these warnings must be followed.
- Always inspect your meter and test leads for any sign of damage or abnormality before every use. If any abnormal conditions exist (i.e. broken test leads, cracked cases, display not reading, etc.), do not attempt to take any measurements.
- Do not expose the instrument to direct sunlight, extreme temperature or moisture.
- Never ground yourself when taking electrical measurements. Keep your body isolated from ground by using dry clothing, rubber shoes, rubber mat or any approved insulating material.
- You always are careful when working with voltages above 60V dc or 30V ac rms. Keep fingers behind the probe barriers while measuring.
- To avoid damages to the instrument, do not exceed the maximum limits of the input values shown in the technical specification tables.
- Never use the meter to measure voltages that might exceed the maximum allowable input value of any

function.

- Never touch exposed wiring, connections or any live circuit when attempting to take measurements.
- Before opening the case, always disconnect test leads from all energized circuits.
- Never use the meter unless the back cover is in place and fastened completely.
- Do not use abrasives or solvents on the meter. To clean it using a damp cloth and mild detergent only.
- Qualified and trained service technicians should only perform calibration and repair of the meter.

4. MAINTENANCE

1. Never touch exposed wiring, connections or any live circuit when attempting to take measurements.
2. Before opening the case, always disconnect test leads from all energized circuits.
3. Never use the meter unless the back cover is in place and fastened completely.
4. Do not use abrasives or solvents on the meter. To clean it using a damp cloth and mild detergent only.
5. Qualified and trained service technicians should only perform calibration and repair of the meter.

5. GENERAL DESCRIPTION

The meter is an autorange professional clamp meter with 3999 counts. For measuring DC and AC voltage, DC and AC current, Resistance, Frequency, Frequency for the clamp, Diode, and Continuity Test with battery operated.

There is the AC measurement to be RMS or TRUE RMS about the meter. It is chosen as user buy.

6. PANEL DESCRIPTION

Transformer jaws

Pick up DC or AC current flowing through the conductor.

Rotary switch

Rotary switch is used to select functions.

HOLD button

When this button is pushed, the display will keep the last reading and “

MAX/MIN button

Press the button to enter the **MAX/MIN** Recording Hold mode. The maximum, minimum values are then reset to the present input. The readings are stored in memory. “**MAX**” or “**MIN**” annunciator turns on to indicate what value is being displayed. Hold this button for more than 3 seconds to return to the normal operating mode.

LCD display

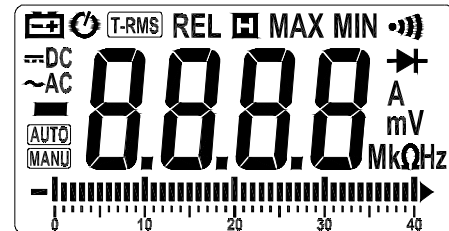

“VWHz” jack

This is positive input terminal for volt, resistance, frequency, diode and Continuity test. Connection is made to it using the red test lead.

“COM” jack

This is negative (ground) input terminal for all measurements except current.

Connection is made to it using the black test lead.

ZERO button

Push the button to get relative measurement mode, “REL” annunciate display on LCD. But store the displayed reading as a reference value. In the Relative mode, the value shown on the LCD is always the difference between the stored reference value and the present reading. If the new reading is the same as the reference value, the display will be zero.

FUNC. button

In \overline{W} or \overline{Hz} range, press this button to select \overline{W} or \overline{Hz} or \overline{Hz} function. Different symbol of function will appear on the LCD.

button

Press the button is used to turn the backlight on. After about 8 seconds, the backlight is auto-off. To turn the backlight on again, just press it once more.

When measuring current, press the button the radius lamp near the clamp is lighted at one time.

Rigger

Press the lever to open the transformer. When the lever is released, the jaws will close again.

7. FORWARD LAYOUT

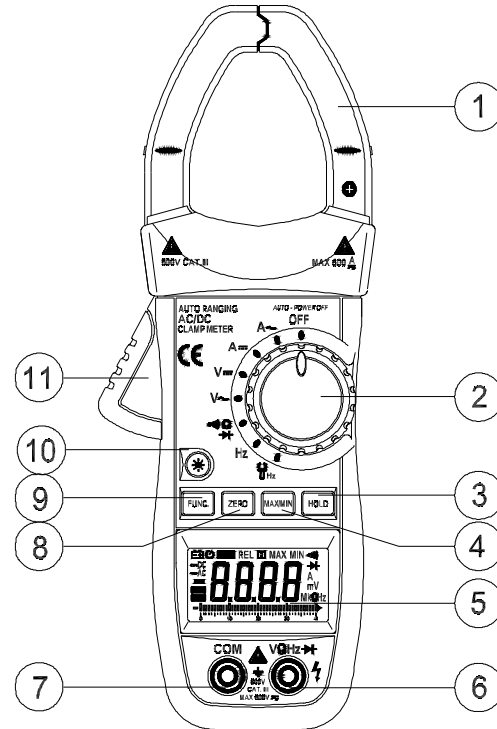

8. OPERATING INSTRUCTIONS

8.1 DC VOLTAGE MEASUREMENT

1. Insert the black and red test leads into the **COM** and **VWHz** input terminals respectively.
2. Set rotary switch at desired $V \overline{\text{---}}$ position.
Connect the test lead tips in parallel with the circuit to be measured. Be careful not to touch any electrical conductors.
3. The polarity of the red lead connection will be indicated along with the voltage value.
4. Read the measure result from the display.

8.2 AC VOLTAGE MEASUREMENT

1. Insert the black and red test leads into the **COM** and **VWHz** input terminals respectively.
2. Set rotary switch at desired $V \sim$ position.
Connect the test lead tips in parallel with the circuit to be measured. Be careful not to touch any electrical conductors.
3. Read the measure result from the display.

8.3 DC CURRENT MEASUREMENT

1. Set the rotary switch at $A \overline{\text{---}}$ position.
2. Press **ZERO** button to enter the zero mode.
3. Press the trigger to open transformer jaw and to clamp one conductor only, making sure that the jaw is firmly closed around the conductor.
4. Read the measure result from the display.

NOTE:

1. Make certain that all test leads are disconnected from the meter terminals.
2. Open and close the clamp jaw several times to

demagnetize the clamp jaw before taking any DC current measurement.

3. To avoid using the backlight when read the measure result from the display.

8.4 AC CURRENT MEASUREMENT

1. Set the rotary switch at desired $A \sim$ position.
2. Press **ZERO** button to enter the zero mode.
3. Press the trigger to open transformer jaw and to clamp one conductor only, making sure that the jaw is firmly closed around the conductor.
4. Read the measure result from the display.

NOTE:

1. Make certain that all test leads are disconnected from the meter terminals.
2. Open and close the clamp jaw several times to demagnetize the clamp jaw before taking any DC current measurement.

8.5 RESISTANCE MEASUREMENT

1. Insert the black and red test leads into the **COM** and **VWHz** input terminals respectively.
2. Set rotary switch at desired $\Omega \overline{\text{---}}$ position.
3. Push **FUNC.** button to select Ω .
4. Connect the test lead tips in parallel with the resistance in the circuit being measured.
5. Read the measure result from the display.

NOTE:

1. If the resistance being measured exceeds the maximum value of the range or the input is not connected, an overrange indication "OL" will be display.

2. When checking in-circuit resistance, be sure the circuit under test has all power removed and that all capacitors have been discharged fully.

8.6 CONTINUITY TESTING

1. Insert the black and red test leads into the **COM** and **VWHz** input terminals respectively.
2. Set rotary switch at desired $\text{W}\cdot\text{Hz}\rightarrow\text{H}\rightarrow\text{L}$ position.
3. Push **FUNC.** button to select $\text{H}\rightarrow\text{L}$.
4. Connect the test lead tips in parallel with the resistance in the circuit being measured. If continuity exists (i.e., resistance less than 40 Ω) built-in buzzer will sound.

8.7 DIODE TESTING

1. Insert the black and red test leads into the **COM** and **VWHz** input terminals respectively.
2. Set rotary switch at desired $\text{W}\cdot\text{Hz}\rightarrow\text{H}\rightarrow\text{L}$ position.
3. Push **FUNC.** button to select $\text{H}\rightarrow\text{L}$. The red lead should be connected to the anode and the black lead to the cathode of the diode.
4. The typical voltage drop should be about 0.6V for silicon diode or 0.3V for germanium diode. If the diode is reverse biased or there is an open circuit the reading displayed will be "OL".

8.8 FREQUENCY MEASUREMENT

1. Insert the black and red test leads into the **COM** and **VWHz** input terminals respectively.
2. Set the rotary switch to **Hz** position.
3. Connect the test leads across the source or load under measurement. The polarity of the red lead connection is positive "+".

- 9 -

4. Read the measure result from the display.

NOTE:

1. The signal amplitude must also be greater than the sensitivity level.
2. Determine that the amplitude level of the signal to be measured is not greater than the input voltage limit (250V DC/AC rms.).

8.9 MEASURING FREQUENCY FOR CLAMP

1. Set the rotary switch to $\text{H}\rightarrow\text{Hz}$ position.
2. Press the trigger to open transformer jaw and to clamp one conductor only, making sure that the jaw is firmly closed around the conductor.
3. Read the measure result of frequency of AC current flowing through the transformer jaw from the display.

NOTE:

Frequency range: 40Hz to 400Hz (> 20A).

9. SPECIFICATIONS

Accuracy:

$\pm\%$ of reading \pm number of least significant digits at 18°C to 28°C, with relative humidity up to 75%.

All specifications assume less than 1 year since calibration. Temperature coefficient:

0.1 \times specified accuracy/ °C.

9.1 GENERAL

Maximum voltage: 1000V CAT II 600V CAT III

Altitude: 2000m

Display: LCD 3999 counts Updates 2-3/sec

Ranging method: Auto range mode

- 10 -

Polarity indication: “-” display for negative polarity

Overrange indication: LCD will display “OL”

Low battery: “ ” will appears on LCD

Jaw capability: 40mm,Max conductor size

Power: Battery1.5V×3  Size AAA

Size: 225mm×86mm×32mm

Weight: Approx. 330g

Operating: 5°C to 35°C

Storage temperature: -10°C to 50°C

9.2 DC VOLTAGE

| Range | Resolution | Accuracy |
|-------|------------|--------------------------|
| 4V | 1mV | ± (0.8%of rdg +5 digits) |
| 40V | 10mV | |
| 400V | 0.1V | |
| 600V | 1V | ± (1.0%of rdg +5 digits) |
| 1000V | 1V | |

Input Impedance: 10MΩ

Overload Protection: 1000V DC or 700V AC RMS

9.3 AC VOLTAGE

| Range | Resolution | Accuracy |
|-------|------------|--------------------------|
| 4V | 1mV | ± (1.2%of rdg +5 digits) |
| 40V | 10mV | |
| 400V | 0.1V | |
| 600V | 1V | ± (2%of rdg +5 digits) |
| 700V | 1V | |

Input Impedance: 10MΩ

Frequency range: 40Hz to 400Hz

Overload Protection: 1000V DC or 700V AC RMS

9.4 DC CURRENT

| Range | Resolution | Accuracy |
|-------|------------|--------------------------|
| 400A | 0.1A | ± (3.0%of rdg +5 digits) |
| 600A | 1A | |
| 1000A | 1A | ± (3.0%of rdg +6 digits) |

Overload Protection: 120% ranges for 60 seconds max

9.5 AC CURRENT

| Range | Resolution | Accuracy |
|-------|------------|--------------------------|
| 400A | 0.1A | ± (2.5%of rdg +5 digits) |
| 600A | 1A | |
| 1000A | 1A | ± (3.0%of rdg +6 digits) |

Frequency range: 50Hz to 60Hz

Overload Protection: 120% ranges for 60 seconds max

9.6 RESISTANCE

| Range | Resolution | Accuracy |
|-------|------------|--------------------------|
| 400Ω | 0.1Ω | ± (1.0%of rdg +5 digits) |
| 4kΩ | 1Ω | |
| 40kΩ | 10Ω | |
| 400kΩ | 0.1kΩ | |
| 4MΩ | 1kΩ | |
| 40MΩ | 10kΩ | ± (2.0%of rdg +6 digits) |

Overload Protection: 250V dc or rms, ac for all ranges

9.7 FREQUENCY



| Range | Resolution | Accuracy |
|--------|------------|------------------------|
| 40Hz | 1Hz | ± (0.1%of rdg +1digit) |
| 400Hz | 1Hz | |
| 4kHz | 10Hz | |
| 40kHz | 100Hz | |
| 100kHz | 100Hz | |

Measurement range: 1V to 10V rms, 40Hz to 100kHz

9.8 FREQUENCY MEASUREMENT FOR CLAMP

| Range | Resolution | Accuracy |
|-------|------------|-------------------------|
| 40Hz | 0.01Hz | ± (0.1% of rdg +1digit) |
| 400Hz | 0.1Hz | |

9.9 AUDIBLE CONTINUITY AND DIODE

| Range | Description |
|---|---|
|  | If continuity exists (about less than 40Ω), built-in buzzer will sound. |
|  | Show the approx. Forward voltage of the diode. |

10. AUTO POWER OFF

To extend the battery life, Auto Power Off function is provided. If no key operations of range changing happen about 30 minutes, the meter will be turned off automatically. To turn it on, pushing the **FUNC.** Button only.

11. REPLACING THE BATTERY

WARNING

To avoid electrical shock or personal injury, remove the test leads and any input signals before replacing the battery. Replace only with same type of battery.

When the electrical tester displays the " " mark or the backlight be not very lit, the battery must be replaced to maintain proper operation. Use the following procedure to replacing the battery:

1. The Rotary Switch is used to select OFF. Disconnect

test leads from any live source and remove the test leads from the input terminals.

2. Remove screws on the battery cover and open the cover.

3. Remove the exhausted battery and replace with three new 1.5V size AAA batteries.

4. Place battery cover and secure by a screw.

CAUTION

Using this appliance in an environment with a strong radiated radio-frequency electromagnetic field (approximately 3V/m) may influence its measuring accuracy.

12. ACCESSORIES

- Operator's instruction manual
- Set of test leads
- Gift box
- Battery 1.5V×3 = Size AAA