

3M™ Automatic HVLP Spray Gun Owner's Manual

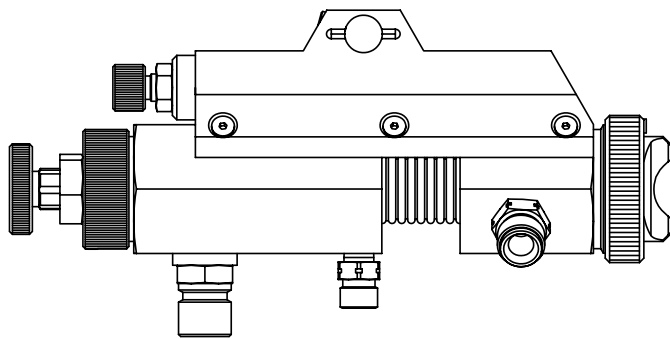

Series 52

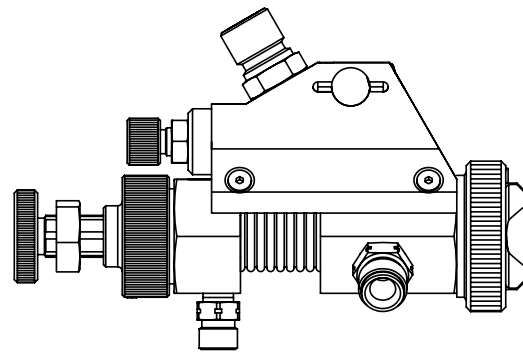
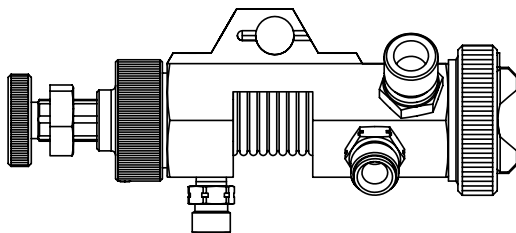

Series 55



Series 56

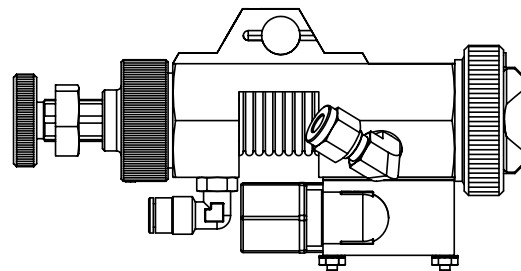

Series 57

 **Read Warnings and Instructions**

This Manual Covers Spray Gun Models 52, 55, 55ZZ, 56, 56ZZ, 57, 57ZZ and 57UL

Manual Available upon request in Spanish

El manual está disponible en español cuando se lo solicite



Table of Contents

Topic	Page Number
Safety Statements	2
Contents-Unpacking	5
Spray Gun Installation Guidelines	8
General Set Up and Spray Gun Use	10
Spray Gun Care and Cleaning	19
Spray Gun Parts Identification Series 52.....	21
Spray Gun Parts Identification Series 55.....	23
Spray Gun Parts Identification Series 55ZZ.....	25
Spray Gun Parts Identification Series 56.....	27
Spray Gun Parts Identification Series 56ZZ.....	29
Spray Gun Parts Identification Series 57.....	31
Spray Gun Parts Identification Series 57ZZ.....	33
Spray Gun Parts Identification Series 57UL	35
Tip/Nozzle/Air Cap Selection Guide	37
Troubleshooting	39

3M™ Automatic HVLP Spray Gun Safety Statements

Read, understand and follow all safety information contained in these instructions prior to set up and operation of any 3M™ Automatic HVLP Spray Gun. Retain these instructions for future reference. Refer to the applicable Material Safety Data Sheet and material container label for each material to be sprayed before using this 3M equipment.

Intended Use:

Each 3M™ Automatic HVLP Spray Gun is intended for use by professionals who are familiar with the possible applicable safety hazards. They are intended to deliver the desired production speed and finish quality for all commonly used coatings.

The spray gun must be set up as specified in the 3M™ Automatic HVLP Spray Gun Owner's Manual. It has not been evaluated for other uses.

Explanation Of Signal Word Consequences	
⚠ WARNING:	Indicates a hazardous situation, which, if not avoided, could result in death or serious injury.
⚠ CAUTION:	Indicates a hazardous situation, which, if not avoided, could result in minor or moderate injury.

Explanation of Product Safety Label Symbols	
	Attention: Read accompanying documentation

⚠ WARNING

To reduce the risks associated with all residual hazards:

- Read, understand, follow and retain for future reference all safety statements in each applicable equipment owner's manual and refer to the applicable Material Safety Data Sheet & material container label for each material to be sprayed before using your 3M equipment.
- This equipment is to be used only by professionals familiar with the possible applicable safety hazards.
- Do not use this product around unsupervised children.
- Never modify any part of this product.
- Always comply with local, state and national codes governing ventilation, fire protection, operation, maintenance, housekeeping and disposal plus all safety statements in applicable owner manuals, MSDS and material container labels.

To reduce the risks associated with chemical exposure:

- Never point a spray gun at anyone else or place any part of your body in front of a spray nozzle.
- Check spray equipment for damage and proper function before use. Repair/replace worn, damaged or malfunctioning components.
- Always wear appropriate, approved personal protective equipment for eye, skin, respiratory and hearing protection per the applicable MSDS and material container labels at all times when spraying.

To reduce the risks associated with fire and explosion:

- Must maintain adequate ventilation per applicable MSDS and material container labels for each material being sprayed in the work area.
- All ignition sources such as smoking must be kept out of the spray area.
- Always maintain a readily available, approved fire extinguisher or other approved fire fighting equipment in the spray area.
- Never use solvents containing Methylene Chloride and Trichloromethane for any reason to avoid a possible violent, explosive chemical reaction when exposed to aluminum or zinc (refer to the manufacturer's MSDS or contact material supplier if there is any doubt to confirm compatibility).

⚠ CAUTION

To reduce the risks associated with lifting and handling:

- Always follow proper lifting and handling practices when moving system components.

To reduce the risks associated with tripping, falling and tipping:

- Route air hoses away from traffic areas.

To reduce the risks associated with hazardous air pressure:

- Maintain spray equipment per 3M care and cleaning instructions in the applicable owner's manual.
- Ensure air input pressure and all applicator system regulators are properly adjusted prior to each use.
- Always follow required air pressure relief procedures for relieving air pressure from the unit.

To reduce the risks associated with compression spring release:

- Maintain a firm grip on fluid adjustment knob when removing.

To reduce the risks associated with environmental contamination:

- Spray materials, solvents, other cleaning materials and electronic components must be disposed of per federal, state and local regulations.

Spray Gun Overview

3M spray guns were designed from the inside out for the effective, efficient, economical application of paints, adhesives, coatings and finishes. These spray guns deliver large spray patterns with very low overspray. The soft, tight, adjustable pattern with complete atomization results in a high finish quality and absolute control. Each light weight spray gun is designed for easy handling, reliability and durability and for minimum maintenance costs.

3M's Automatic HVLP spray guns deliver superior atomization for a wide range of coatings. The standard spray gun body is made of light weight aluminum. The Zinc HVLP Automatic Spray Gun body is made of composite material. Manufactured for durability and dependability, both versions are easy to maintain for long-lasting performance.

3M equipment is for professional use only. Hazards can occur from equipment misuse. Any misuse of the equipment or accessories, such as over pressurizing, modifying parts, using incompatible chemicals and fluids, or using worn or damaged parts can cause serious bodily injury, fire, explosion or property damage. **Please read and follow all Safety Statements and Instructions.**

Contents

Unpacking

Remove the components from the box. Inspect for concealed damage and/or missing items. If you discover any damage and/or missing pieces, contact your distributor immediately.

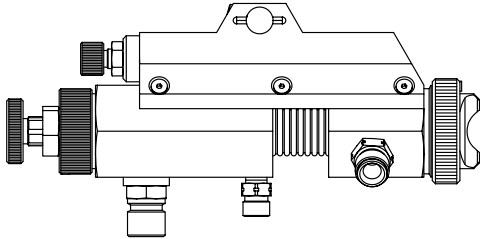

3M™ Series 52 HVLP Automatic Spray Gun

All Series 52 HVLP Automatic Spray Guns are non-bleed spray guns with low pressure air inlets and a manual rear fan control. These spray guns are available with an aluminum gun body, 10 cfm air consumption, 1:1 reduction ratio, 3/4" air inlet connection, and a 10 psi maximum inlet air pressure*. These spray guns are most commonly used for stationary or reciprocator mounting applications.

* Maximum inlet pressure will yield approximately 10 psi at the air cap.

Contents cont.

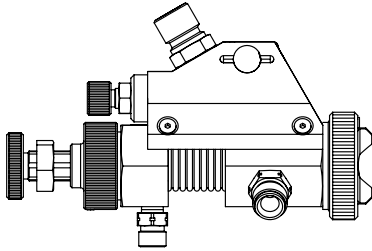

3M™ Series 55 HVLP Automatic Spray Gun

3M™ Series 55ZZ HVLP Automatic Spray Gun (Zinc)

All Series 55 HVLP Automatic Spray Guns are bleeder spray guns with low pressure air inlets and a manual rear fan control. These spray guns are available with an aluminum gun body or a composite gun body with composite wetted components for zinc compatibility. The technical specifications include 10 cfm air consumption, 1:1 reduction ratio, 3/4" air inlet connection, and a 10 psi maximum inlet air pressure*. These guns are most commonly used for stationary or reciprocator mounting applications.

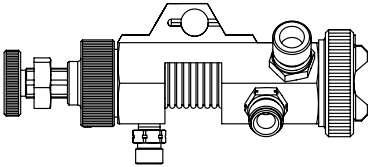

3M™ Series 56 HVLP Automatic Spray Gun

3M™ Series 56ZZ HVLP Automatic Spray Gun (Zinc)

All Series 56 HVLP Automatic Spray Guns are bleeder spray guns with dual air inlets for separate control of atomization and fan air pressures. These spray guns are available with an aluminum gun body or a composite gun body with composite wetted components for zinc compatibility. The technical specifications include 10 cfm air consumption, 1:1 reduction ratio, 3/4" air inlet connection, and a 10 psi maximum inlet air pressure*. These guns are most commonly used for robotic and remote control applications.

* Maximum inlet pressure will yield approximately 10 psi at the air cap.

Contents cont.

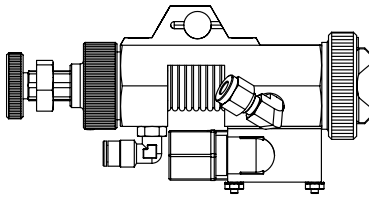

3M™ Series 57 HVLPAutomatic Spray Gun

All Series 57 HVLPAutomatic Spray Guns are bleeder spray guns with dual air inlets for separate control of atomization and fan air pressures. These spray guns are available with an aluminum gun body. The technical specifications include 10 cfm air consumption, 1:1 reduction ratio, $\frac{3}{4}$ " air inlet connection, and a 10 psi maximum inlet air pressure*. These guns are most commonly used for robotic and remote control applications.

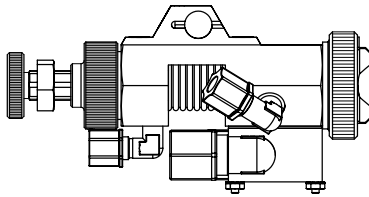

3M™ Series 57ZZ HVLPAutomatic Spray Gun (Zinc)

All 57ZZ Series HVLPAutomatic Spray Guns are bleeder spray guns with dual air inlets for separate control of atomization and fan air pressures. These spray guns are available with a composite gun body with composite wetted components for zinc compatibility. The technical specifications include 10 cfm air consumption, 1:1 reduction ratio, $\frac{3}{4}$ " air inlet connection, and a 10 psi maximum inlet air pressure*. These guns are most commonly used for robotic and remote control applications.

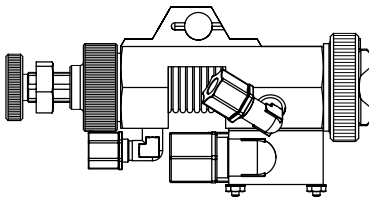

3M™ Series 57UL HVLPAutomatic Spray Gun (Ultralight)

All 57UL Series HVLPAutomatic Spray Guns are bleeder spray guns with dual air inlets for separate control of atomization and fan air pressures. These spray guns are available with a composite gun body. The technical specifications include 10 cfm air consumption, 1:1 reduction ratio, $\frac{3}{4}$ " air inlet connection, and a 10 psi maximum inlet air pressure*. These guns are most commonly used for robotic and remote control applications.

* Maximum inlet pressure will yield approximately 10 psi at the air cap.

Spray Gun Installation Guidelines

3M™ Series 52 HVLP Automatic Spray Gun

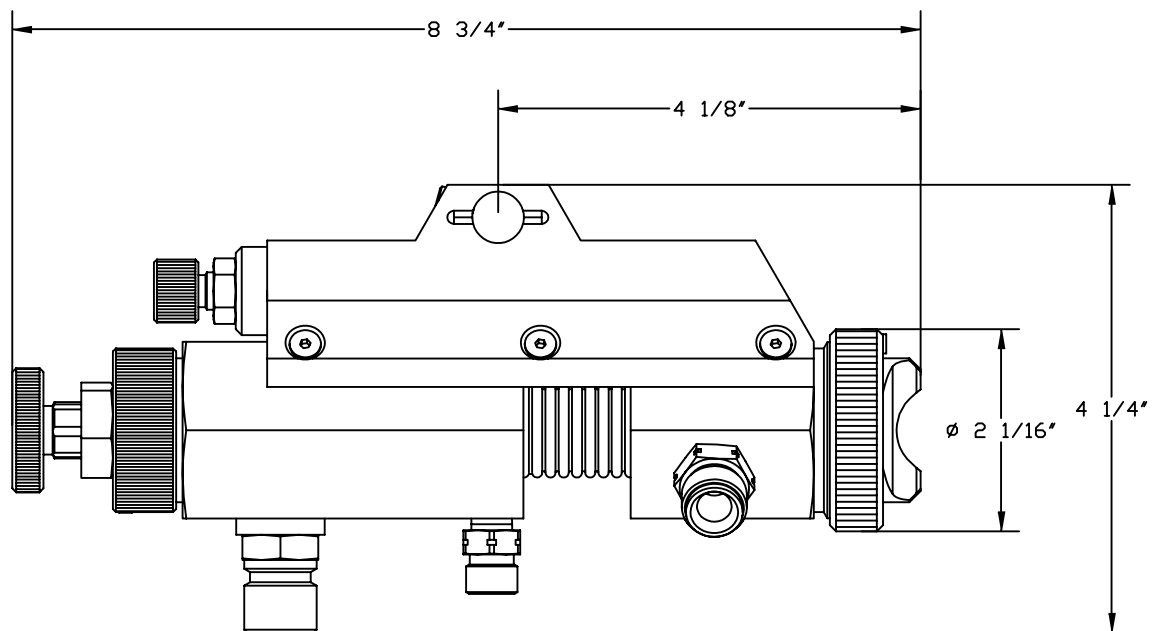

3M™ Series 55 HVLP Automatic Spray Gun

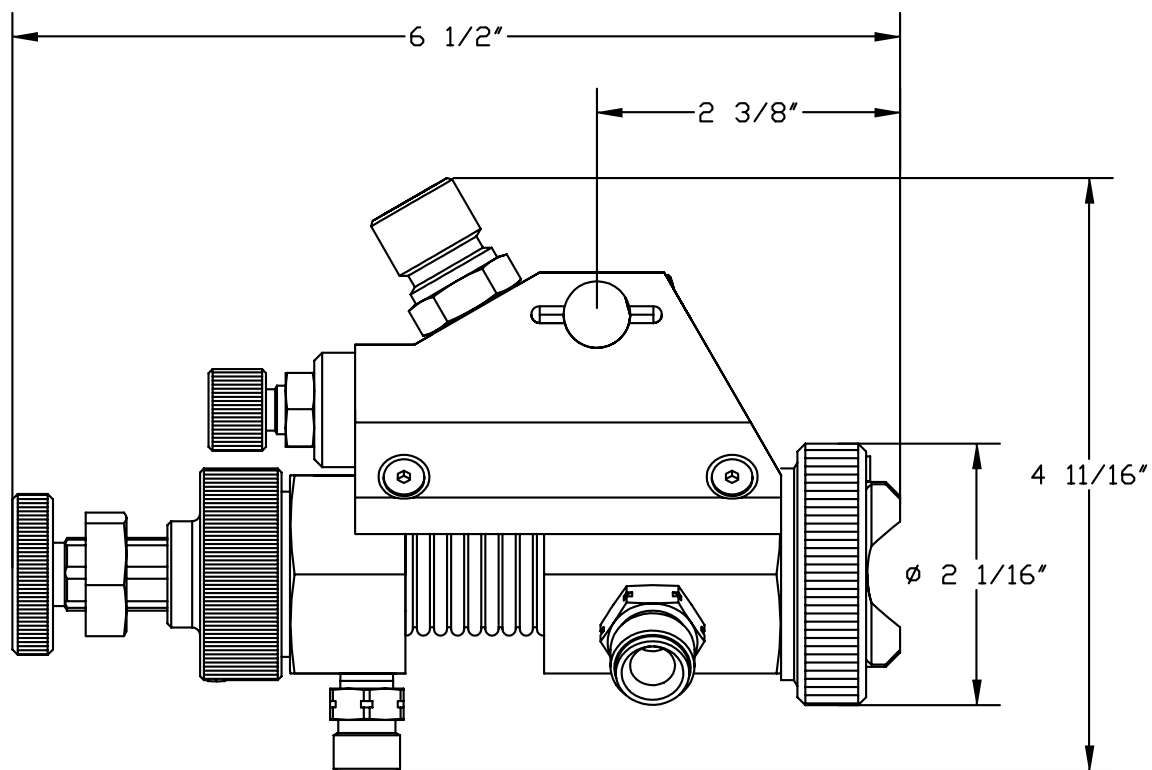

Spray Gun Installation Guidelines cont.

3M™ Series 56 HVLP Automatic Spray Gun

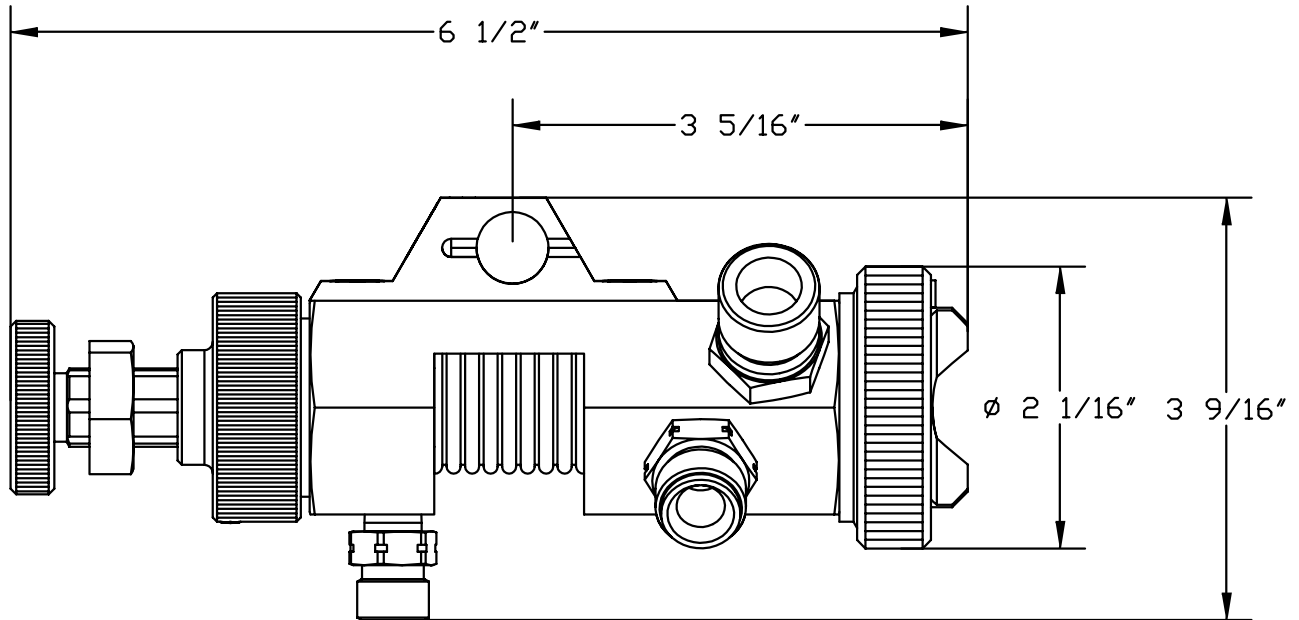

3M™ Series 57 HVLP Automatic Spray Gun

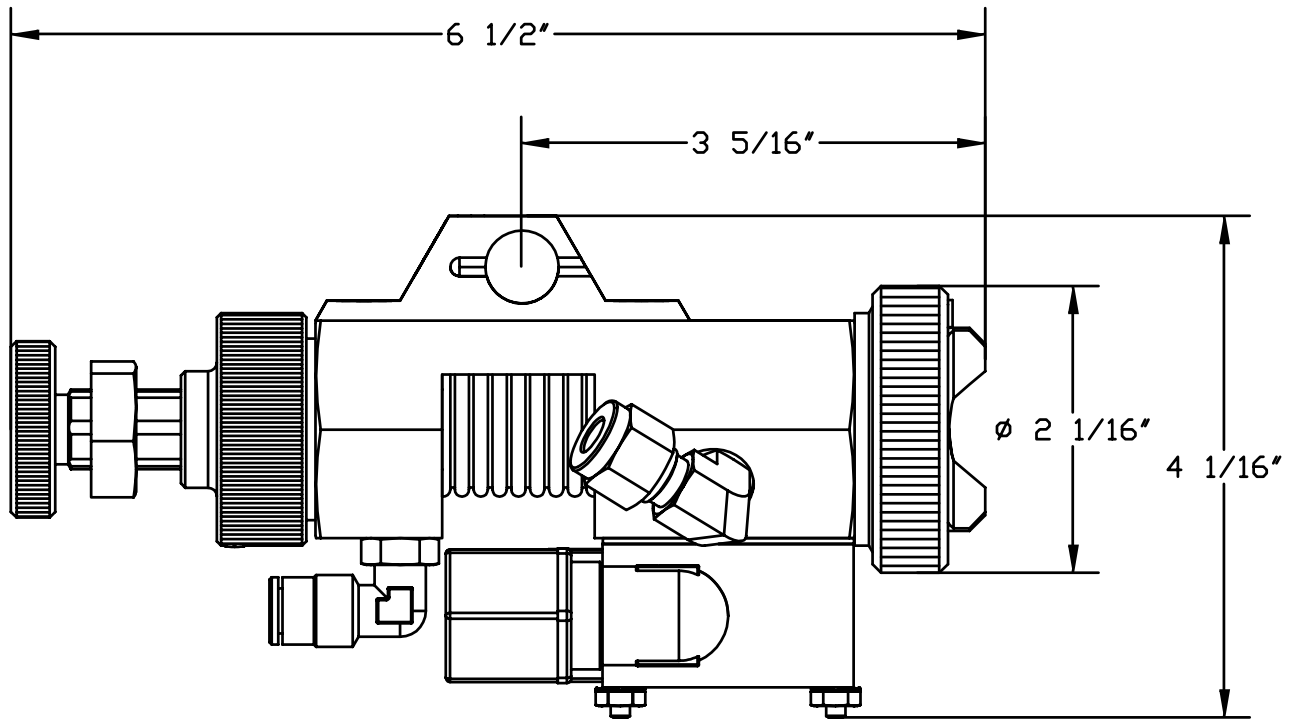

General Set Up and Spray Gun Use

For additional instructions refer to your fluid source manual.

3M™ Series 52 HVLP Automatic Spray Gun Connection Diagram

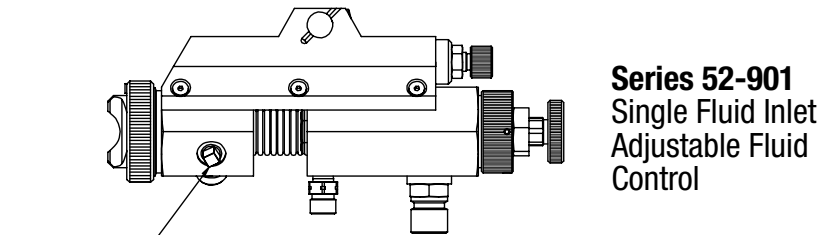
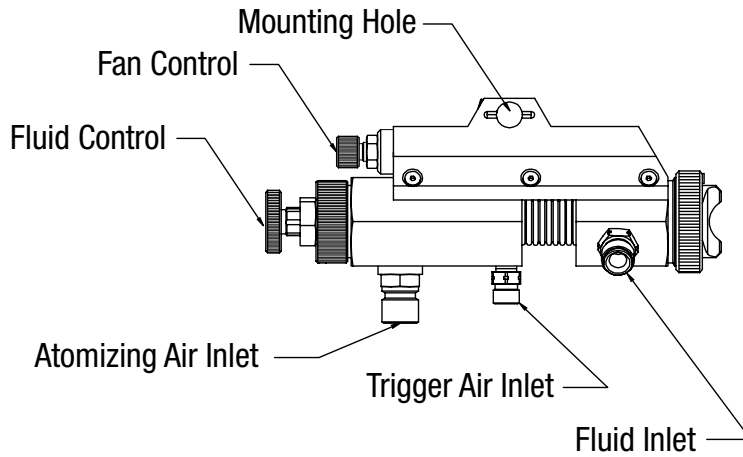

Series 52-901
Single Fluid Inlet
Adjustable Fluid Control

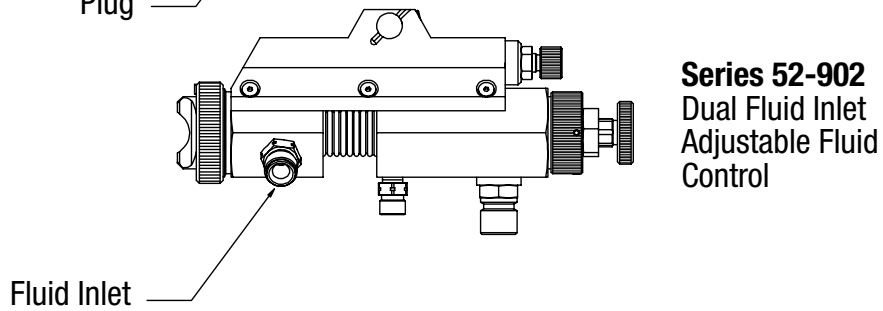

Series 52-902
Dual Fluid Inlet
Adjustable Fluid Control

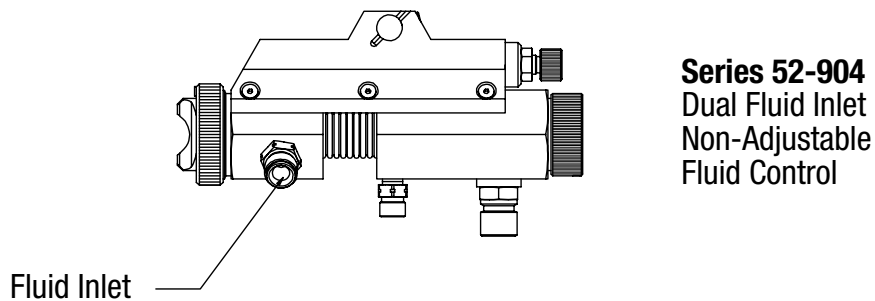

Series 52-904
Dual Fluid Inlet
Non-Adjustable Fluid Control

General Set Up and Spray Gun Use cont.

3M™ Series 55 HVLP Automatic Spray Gun Connection Diagram

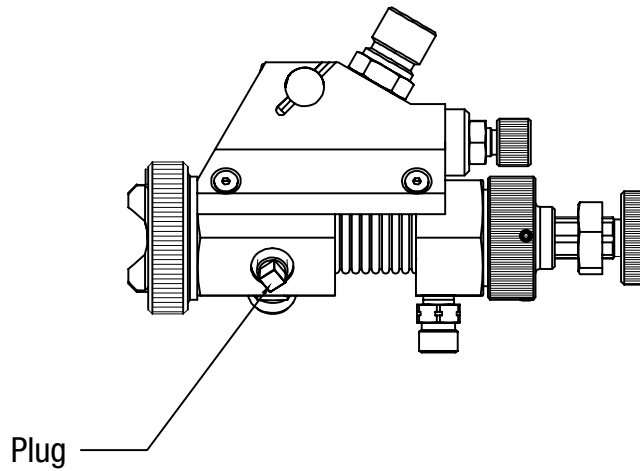
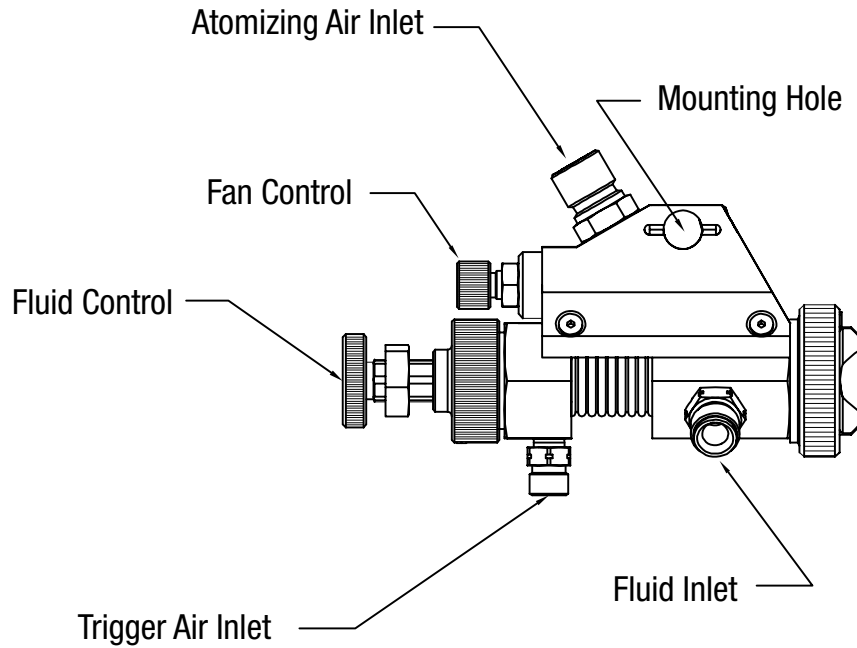

Series 55-901 Series
Single Fluid Inlet
Adjustable Fluid Control

General Set Up and Spray Gun Use cont.

3M™ Series 55ZZ HVLP Automatic Spray Gun Connection Diagram

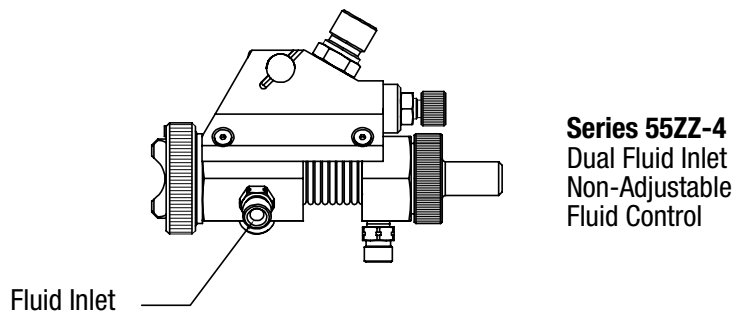
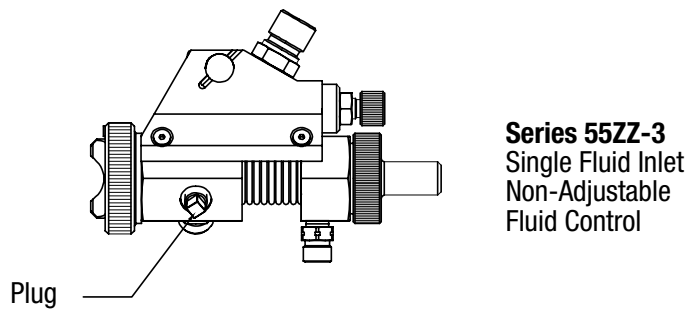
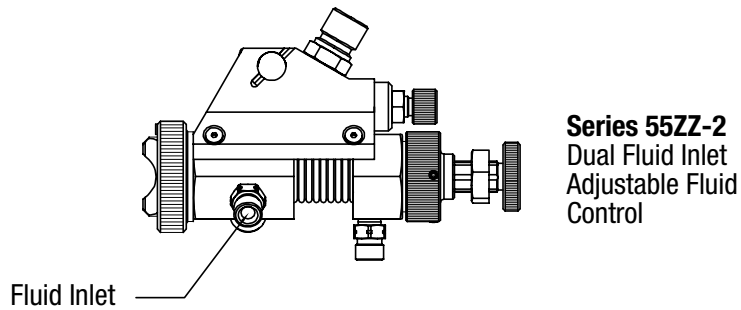
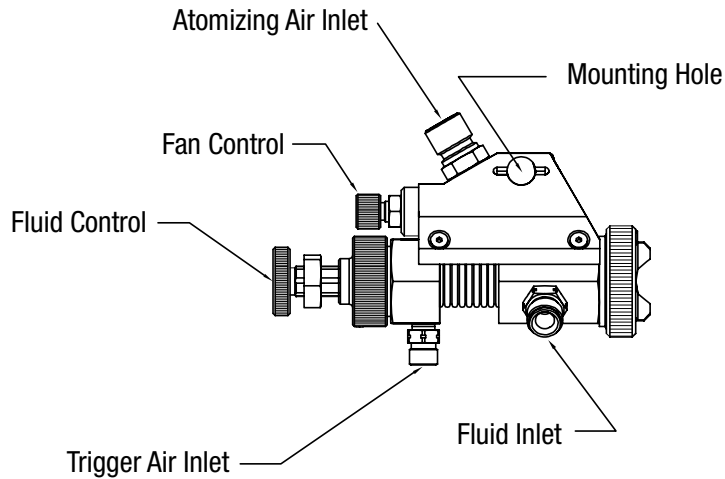

General Set Up and Spray Gun Use cont.

3M™ Series 56 HVLP Automatic Spray Gun Connection Diagram

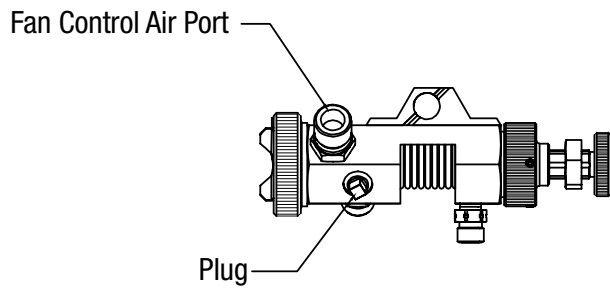
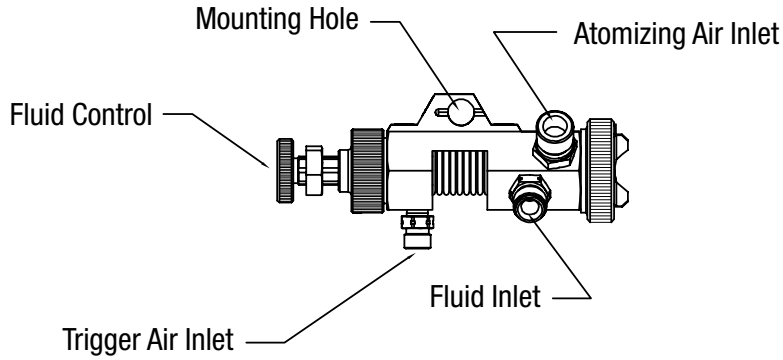

Series 56-901
Single Fluid Inlet
Adjustable Fluid
Control

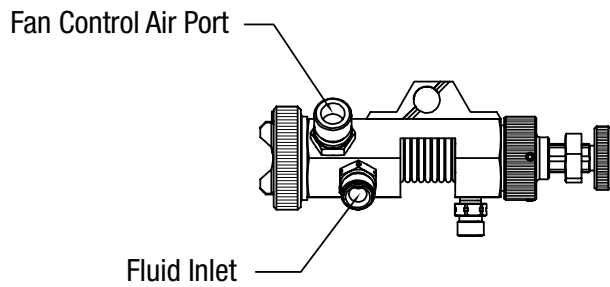

Series 56-902
Dual Fluid Inlet
Adjustable Fluid
Control

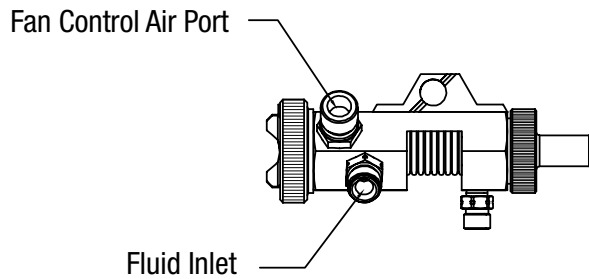

Series 56-904
Dual Fluid Inlet
Non-Adjustable
Fluid Control

General Set Up and Spray Gun Use cont.

3M™ Series 56ZZ HVLV Automatic Spray Gun Connection Diagram

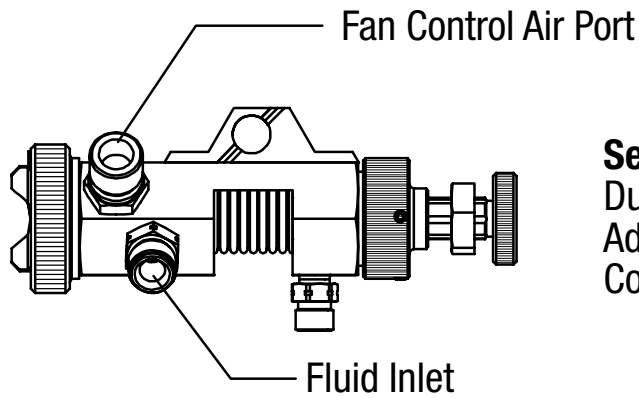
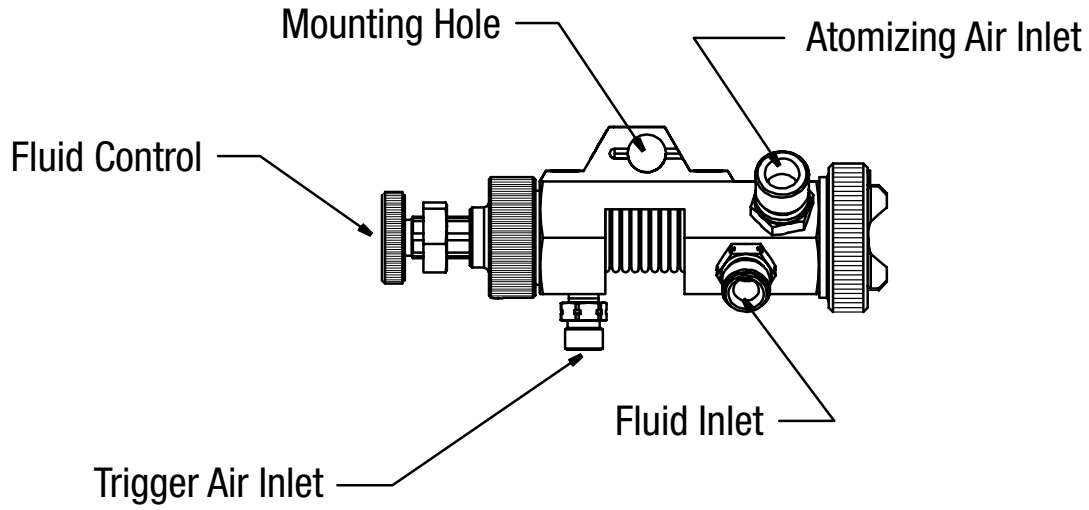

Series 56ZZ-2
Dual Fluid Inlet
Adjustable Fluid
Control

General Set Up and Spray Gun Use cont.

3M™ Series 57 HVLP Automatic Spray Gun Connection Diagram

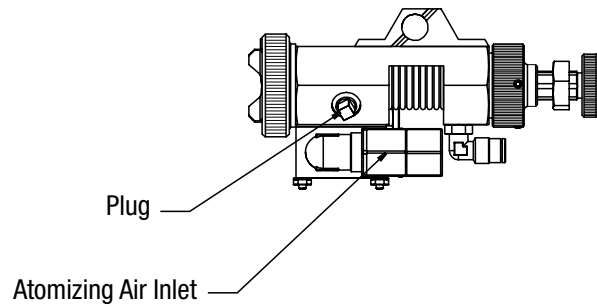
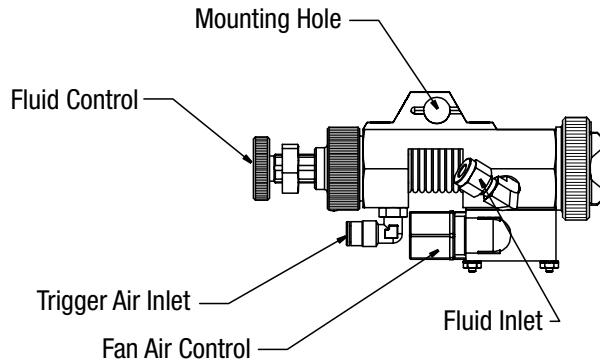

Series 57-901
Single Fluid Inlet
Adjustable Fluid
Control

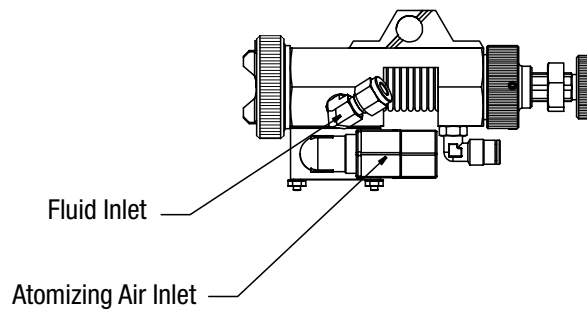

Series 57-902
Dual Fluid Inlet
Adjustable Fluid
Control

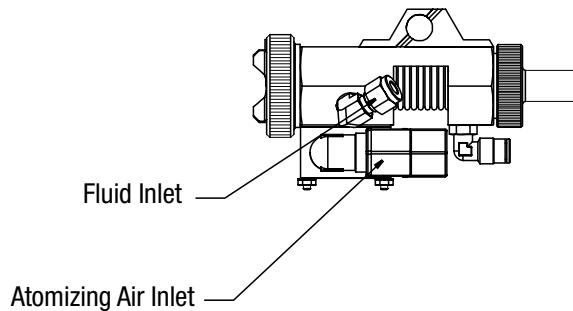

Series 57-904
Dual Fluid Inlet
Non-Adjustable
Fluid Control

General Set Up and Spray Gun Use cont.

3M™ Series 57ZZ HVLV Automatic Spray Gun Connection Diagram

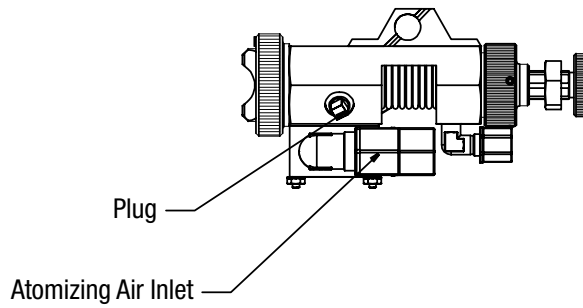
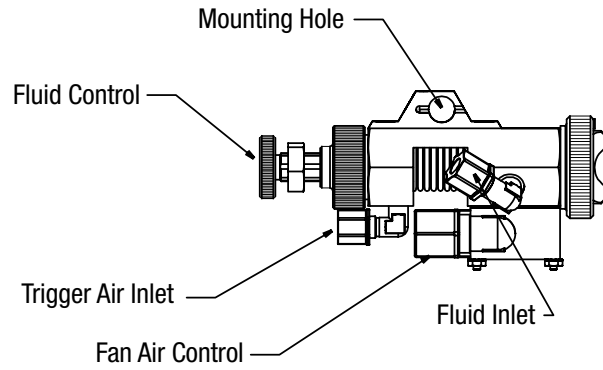

Series 57ZZ-1
Single Fluid Inlet
Adjustable
Fluid Control

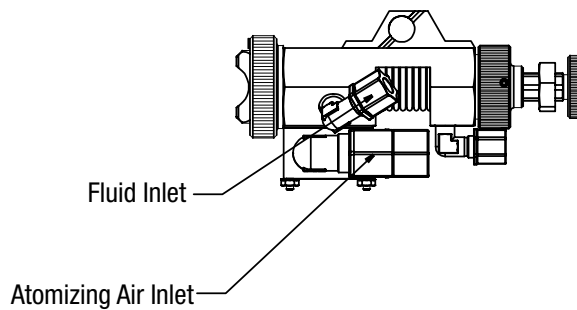

Series 57ZZ-2
Dual Fluid Inlet
Adjustable
Fluid Control

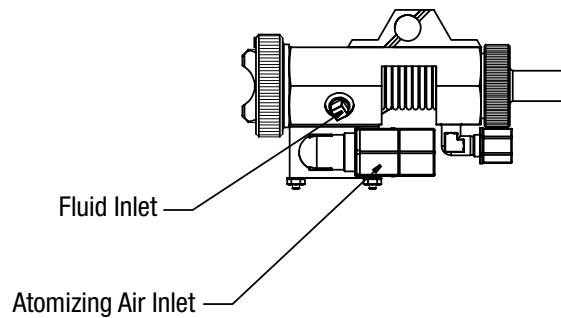

Series 57ZZ-3
Single Fluid Inlet
Non-Adjustable
Fluid Control

General Set Up and Spray Gun Use cont.

3M™ Series 57UL HVLP Automatic Spray Gun Connection Diagram

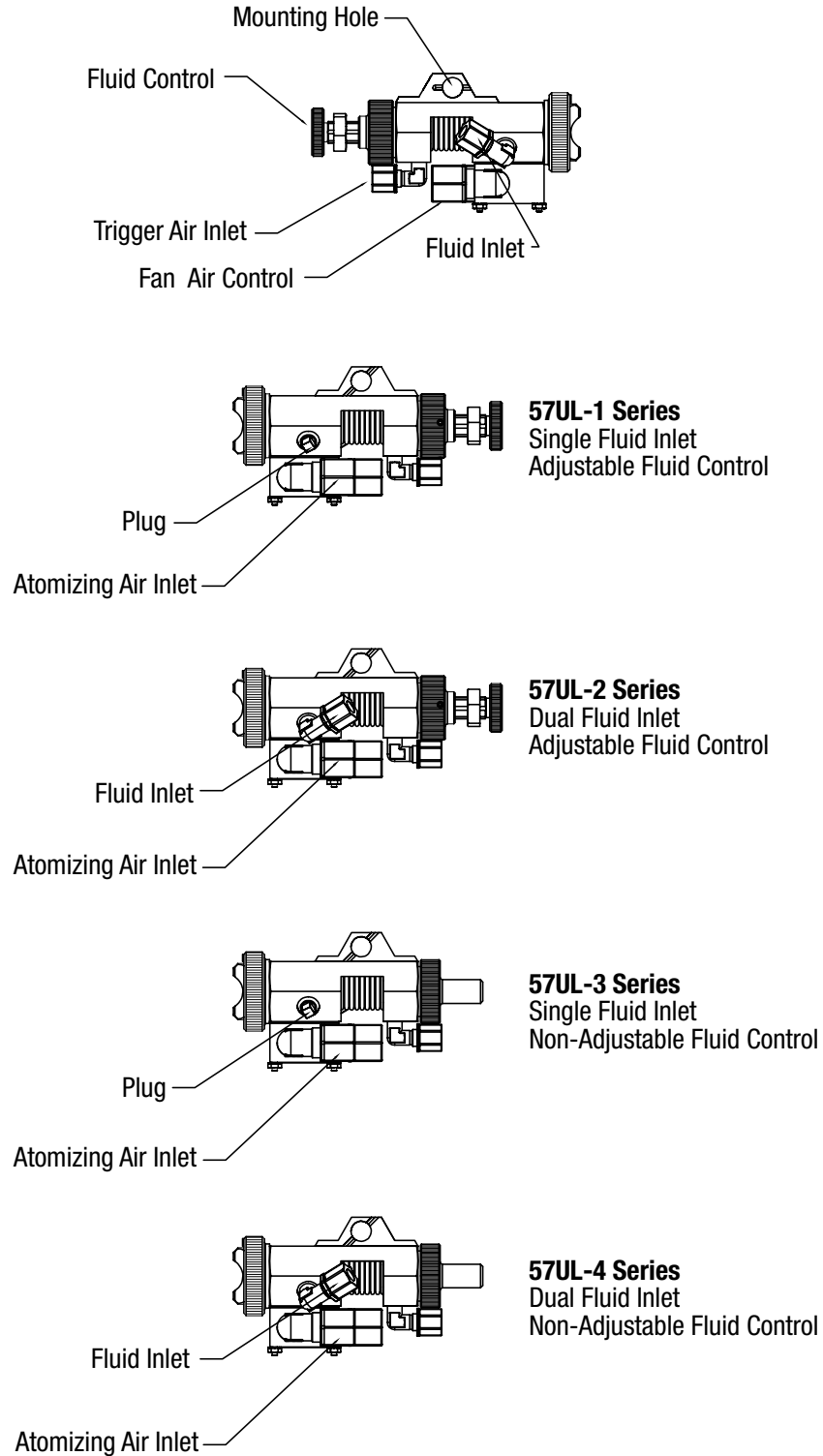

General Set Up and Spray Gun Use cont.

Adjusting the Fluid Flow

The adjustable fluid control is located at the rear of the spray gun (if equipped). As a starting point, gently turn the knob clockwise until you have very little needle travel. Do not over-tighten. After the needle travel has stopped, further tightening will only serve to compress the spring and will not aid in adjustment. Next turn the knob counterclockwise two full turns. These adjustment procedures will serve only as a starting point. Fine tuning of these adjustments will be based on your material and technique.

Adjusting the Fan Pattern Size

The fan adjustment screw is located at the top of the Series 52 and Series 55 models, and the fan is adjusted by remote on the Series 56 and Series 57. As a starting point, gently turn the knob clockwise until you feel no further adjustment. Next, turn the knob counter-clockwise one full rotation. The fan adjustment will allow you to spray from a small round to a full fan pattern. The pattern can also be changed from vertical to horizontal by rotating the air cap a ¼ turn.

Note: The small round pattern can be achieved by closing down the fan adjustment.

Spray Technique

1. To achieve the best results when spraying material, keep the spray gun perpendicular to the surface and maintain a consistent distance of approximately 6 to 8 inches (160-200 mm) from the object being sprayed.
2. Apply coating with 50% overlap to achieve an even finish.

Note: Your spray gun may be made from aluminum and may contain aluminum components. Certain solvents containing Methylene Chloride and Trichloromethane are not chemically compatible with aluminum.

Read, understand and follow all safety statements as well as wear appropriate, approved personal protective equipment per the applicable MSDS and material container labels for cleaning solutions.

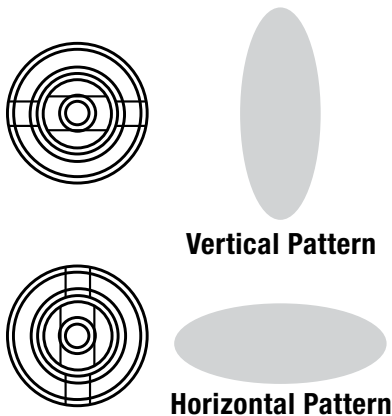

Spray Gun Care and Cleaning

Lubrication:

Regular lubrication is important to maintain the high performance of your HVLP Automatic Spray Gun. Every time your spray gun is cleaned, the oil that lubricates the friction points is washed away.

You must lubricate all working threads after every cleaning. We recommend using a lubricant such as petroleum jelly. Using lubricants containing silicone can contaminate your entire finishing department. The following illustrations identify the spray gun lubrication points.

3M™ Series 52

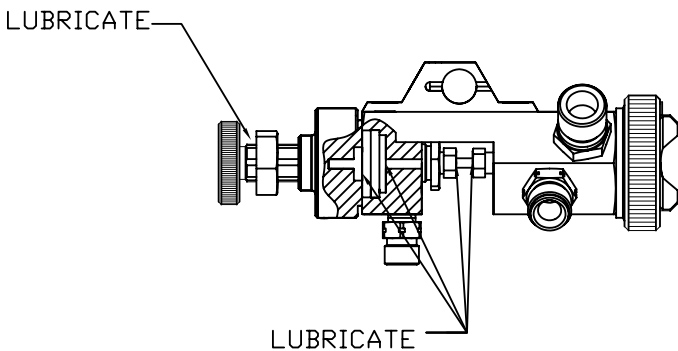

3M™ Series 55

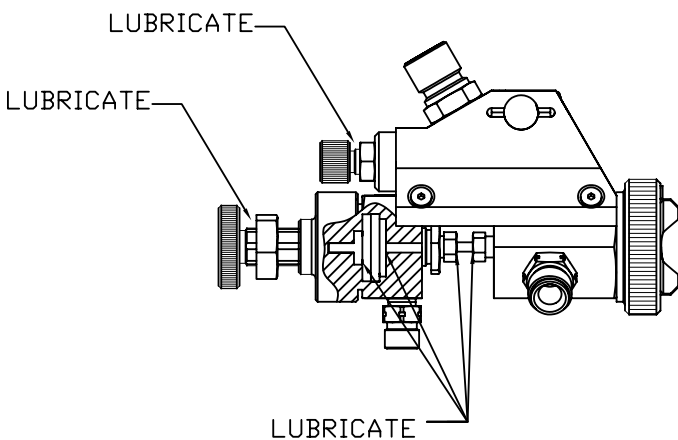

3M™ Series 56

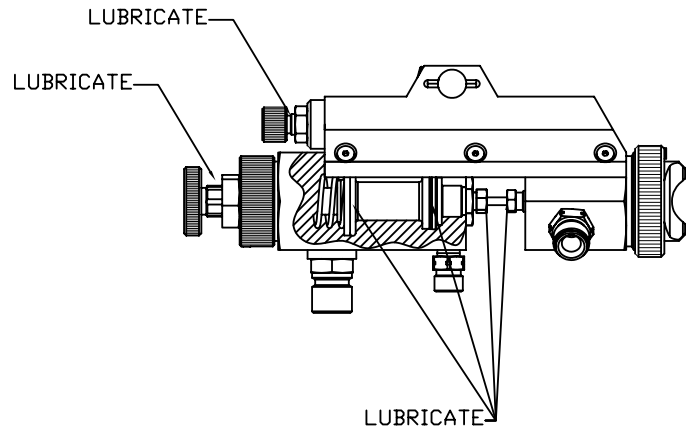

3M™ Series 57

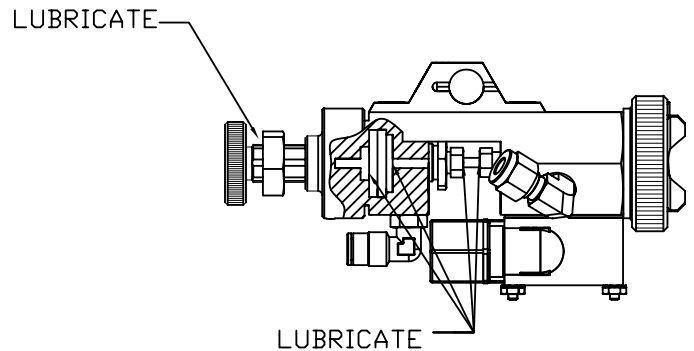

General System Maintenance

- ✓ Relieve the pressure from the spray gun before servicing.
 1. Turn off the air supply to the spray gun.
 2. Disconnect air line from the spray gun.
- ✓ Clean the fluid and air line filters daily.
- ✓ Check for any fluid leakage from the spray gun and fluid hoses.
- ✓ Flush the spray gun before changing colors and when done operating the spray gun.

Spray Gun Care and Cleaning cont.

ATTENTION

Solvent left in the spray gun air passages could result in a poor quality paint finish. Do not use any cleaning method which may allow solvent into the spray gun air passages. Do not expose air regulators and gauges to solvent as damage may occur.

Cleaning Process

1. Relieve the pressure from the spray gun before servicing.
2. Refer to your fluid source manual for removal and cleaning.
3. To retain unused material or temporarily store mixed material, see your Local, State, Federal and OSHA guidelines, along with material manufacturer's recommendations for storage.
4. Flush the spray gun. To flush spray gun, run water or compatible and compliant solvent into the spray gun fluid passage while triggering the spray gun.
5. Remove the retaining ring and air cap.
6. Unscrew the fluid needle tip with fingers.
7. Dip the end of a soft-bristle brush into a compatible solvent. Do not continuously soak the brush's bristles with solvent, and do not use a wire brush.

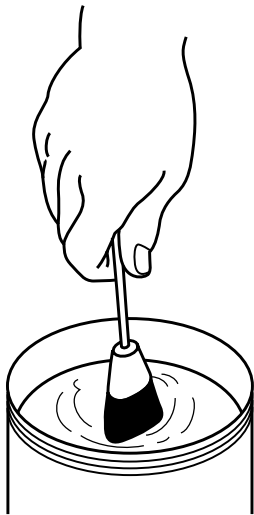

8. Clean the front of the spray gun, using a soft-bristle brush and solvent.
9. Scrub the retaining ring, air cap and fluid nozzle with a soft-bristle brush. To clean out air cap holes, use a small brush.

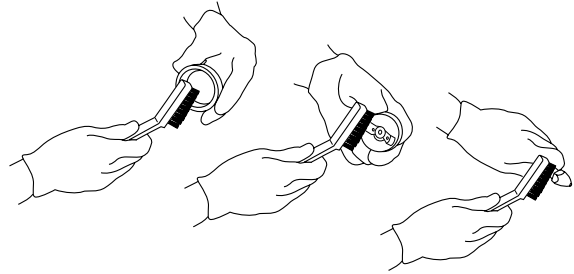

10. Clean the air cap and fluid nozzle after each use. Do not use metal tools to clean the air cap holes as this may scratch them; scratches can distort the spray pattern. Do not soak the retaining ring in solvent for prolonged periods of time.

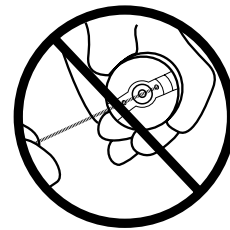

11. Thread fluid needle tip on finger tight. Tighten the nozzle securely to obtain a good seal.
12. Install the retaining ring and air cap.
13. Dampen a soft cloth with solvent and wring-out the excess. Wipe off the outside of the spray gun.

3M™ Series 52 HVLP Automatic Spray Gun Parts Identification

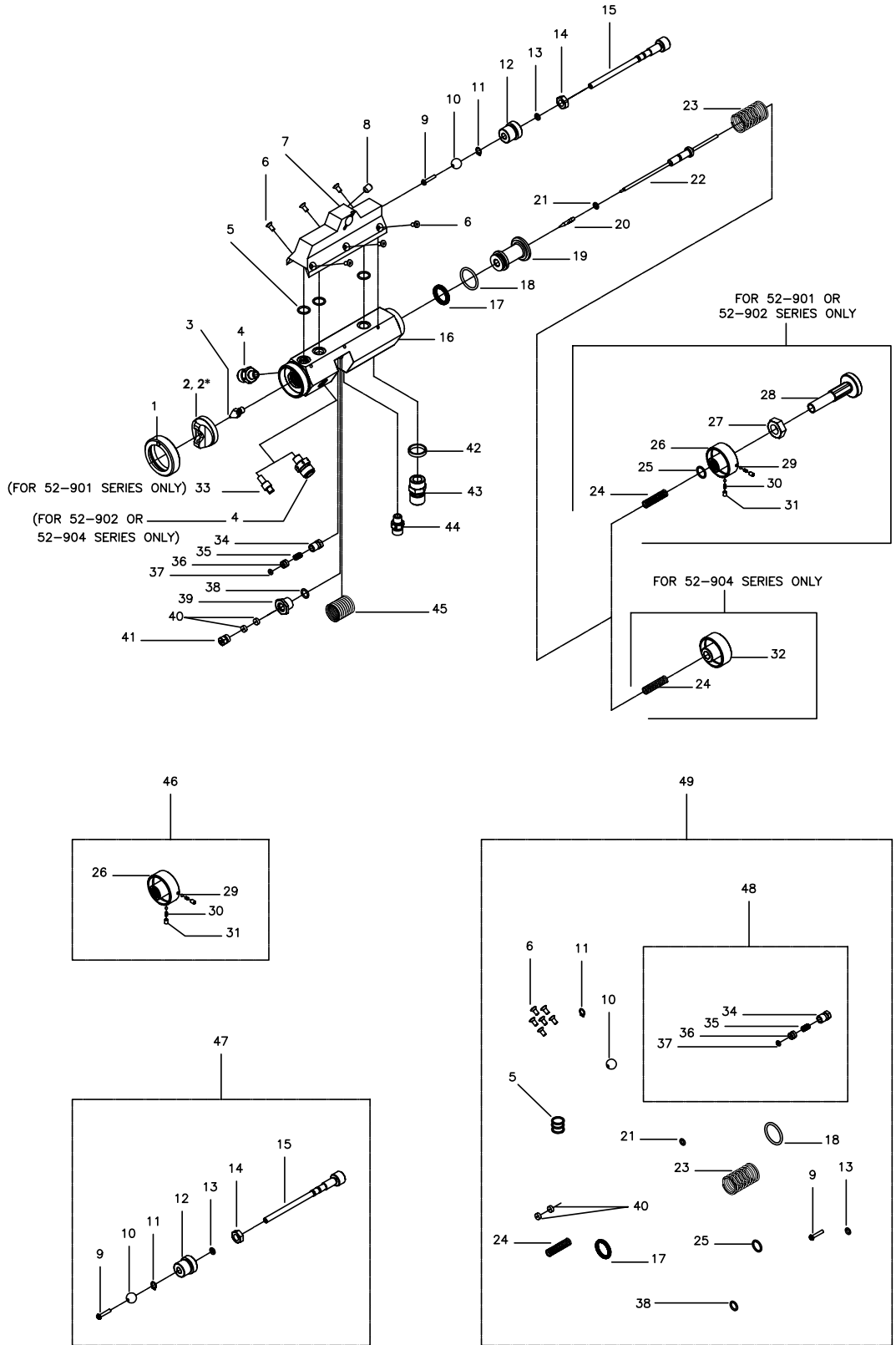

3M™ Series 52 HVLP Automatic Spray Gun Parts Identification

Item	Description	Replacement PN	
1	Retaining Ring	91-043	
2	Air Cap (Composite)	91-009-XXX	
2*	Air Cap (Aluminum)	91-071-XXX	
3	Fluid Nozzle		
4	Fluid Fitting	95-025	
5	O-Ring		
6	Flat Head Screw		
7	Air Manifold	95-002	
8	Set Screw	UH-612/5	(Pack of 5)
9	Philips Pan Head Screw		
10	Valve Seal Ball		
11	Snap Ring		
12	Fan Valve Body	95-014	
13	O-Ring		
14	Hex Jam Nut		
15	Valve Stem	95-015	
16	Autogun Body Assembly	95-022	
17	Cylinder Seal (U-Cup)	95-018	
18	O-Ring		
19	Piston 95-005		
20	Needle Tip (Delrin®)	91-107-XXX/4	(Pack of 4)
21	O-Ring	UH-768/5	(Pack of 5)
22	Needle Shaft	95-010	
23	Piston Return Spring		
24	Needle Return Spring		
25	O-Ring		
26	Cylinder Cap (Adjustable)		
27	Stainless Steel Ball	UH-610	
28	Compression Spring	95-013	
29	Set Screw	UH-691/5	(Pack of 5)
30	Jam Nut UH-824		
31	Needle Adjustment Screw	95-007	
32	Cylinder Cap (Non-Adjustable)	95-071	
33	Plug	95-077	
34	Packing Nut		
35	Compression Spring		
36	Needle Guide		
37	O-Ring	UH-1405/10	(Pack of 10)
38	O-Ring	UH-647/10	(Pack of 10)
39	Seal Housing	95-017	
40	Teflon® Seal	95-020/2	(Pack of 2)
41	Seal Nut	95-016	
42	Spacer	95-073	
43	Quick Disconnect Fitting	80-874	
44	Connection – ¼ NPS x 1/8 NPT	80-932	
45	Needle Cover	95-102	
46	Cylinder Cap (Adjustable) Assembly	95-039	
47	Fan Control Assembly	94-041	
48	Fluid Packing Kit	91-200	
49	Universal Maintenance Kit	95-043	

Note: For all part numbers with X, see page 37

* Denotes difference in material



3M™ Series 55 HVLP Automatic Spray Gun Parts Identification

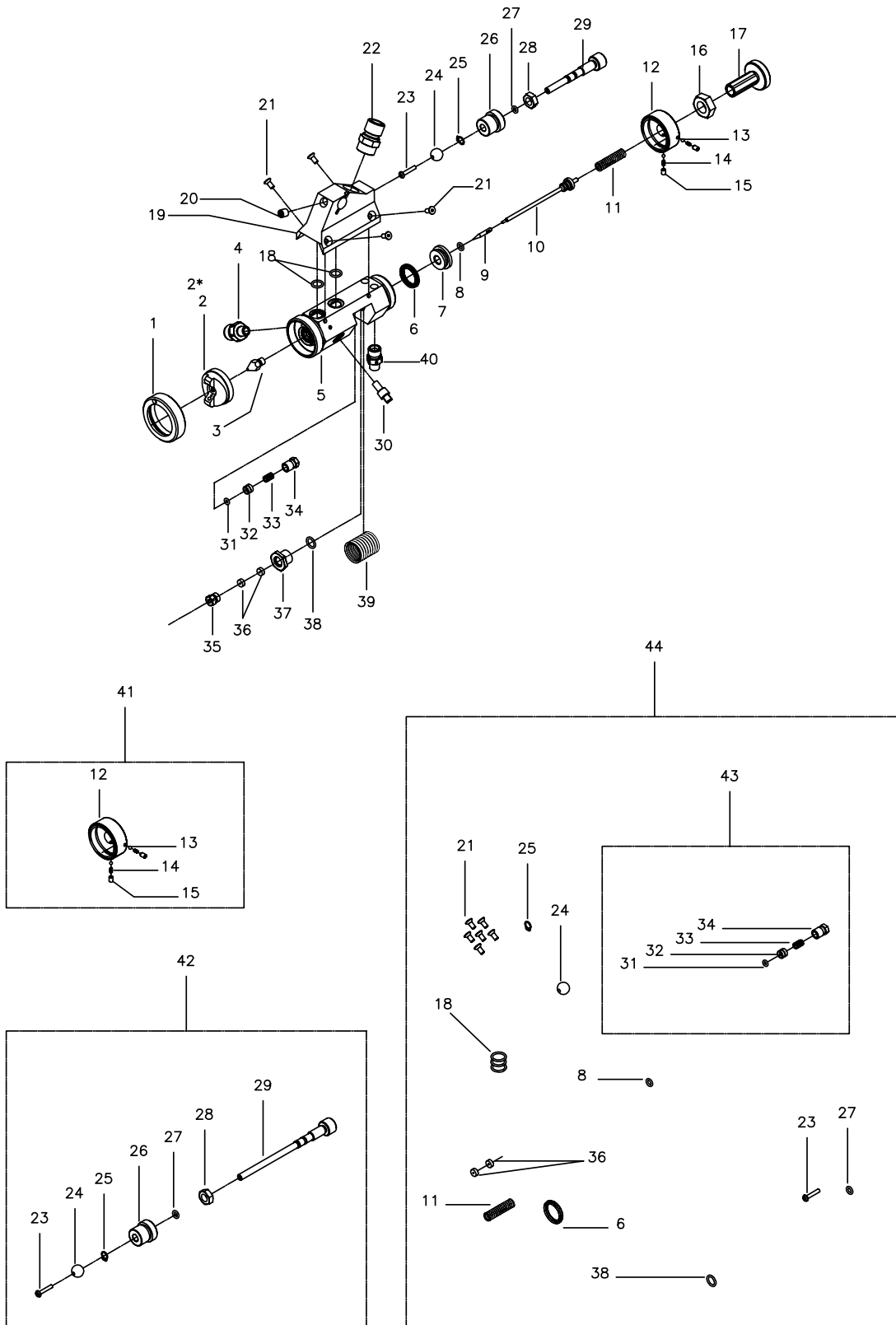

3M™ Series 55 HVLP Automatic Spray Gun Parts Identification

Item	Description	Replacement PN	
1	Retaining Ring	91-043	
2	Air Cap (Composite)	91-009-XXX	
2*	Air Cap (Aluminum)	91-071-XXX	
3	Fluid Nozzle		
4	Fluid Fitting	95-025	
5	Autogun Body Assembly	95-028	
6	Cylinder Seal (U-Cup)	95-018	
7	Piston	95-031	
8	O-Ring	UH-768/5	(Pack of 5)
9	Needle Tip (Delrin®)	91-107-XXX/4	(Pack of 4)
10	Needle Shaft	95-033	
11	Needle Return Spring		
12	Cylinder Cap (Adjustable)		
13	Stainless Steel Ball	UH-610	
14	Compression Spring	95-013	
15	Set Screw	UH-691/5	(Pack of 5)
16	Jam Nut	UH-824	
17	Needle Adjustment Screw	95-032	
18	O-Ring		
19	Air Manifold	95-030	
20	Set Screw	UH-612/5	(Pack of 5)
21	Flat Head Screw		
22	Air Inlet Fitting		
23	Phillips Pan Head Screw		
24	Valve Seal Ball		
25	Snap Ring		
26	Fan Valve Body	95-014	
27	O-Ring		
28	Hex Jam Nut		
29	Valve Stem	95-036	
30	Plug	95-077	
31	O-Ring	UH-1405/10	(Pack of 10)
32	Needle Guide		
33	Compression Spring		
34	Packing Nut		
35	Seal Nut		
36	Teflon® Seal	95-020/2	(Pack of 2)
37	Seal Housing	95-017	
38	O-Ring	UH-647/10	(Pack of 10)
39	Needle Cover	95-102	
40	Fluid Inlet Fitting	80-932	
41	Cylinder Cap (Adjustable) Assembly	95-040	
42	Fan Control Assembly	95-042	
43	Fluid Packing Kit	91-200	
44	Universal Maintenance Kit	95-043	

Note: For all part numbers with X, see page 37

* Denotes difference in material



3M™ Series 55ZZ HVLP Automatic Spray Gun Parts Identification

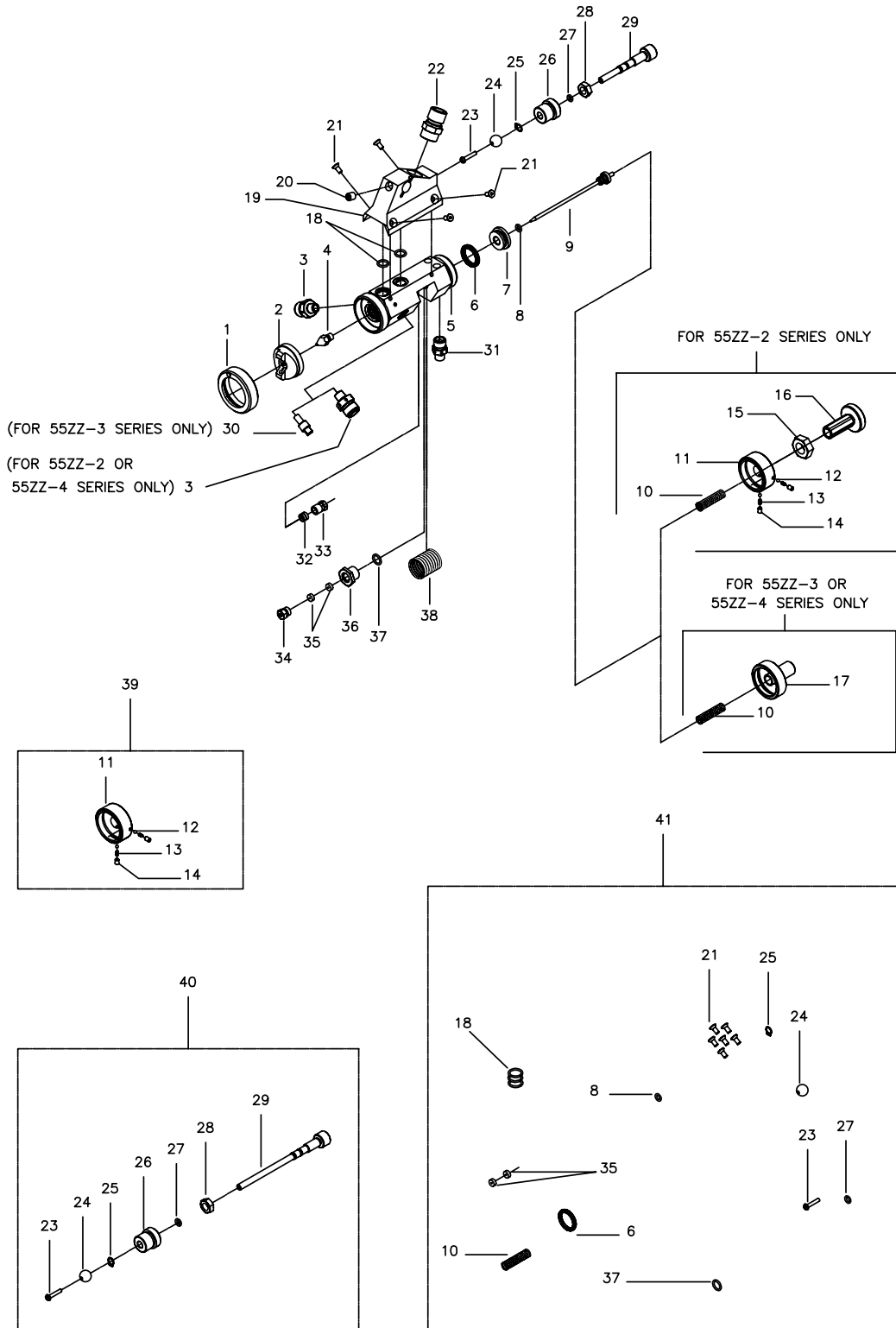

3M™ Series 55ZZ HVLP Automatic Spray Gun Parts Identification

Item	Description	Replacement PN	
1	Retaining Ring	91-043	
2	Air Cap (Composite)	91-009-XXX	
3	Fluid Fitting	95-025	
4	Delrin® Fluid Nozzle	91-148-XXX	
5	Autogun Body Assembly	95-028	
6	Cylinder Seal (U-Cup)	95-018	
7	Piston	95-031	
8	O-Ring	UH-768/5	(Pack of 5)
9	Full Delrin® Needle Assembly	95-048-XXX	
10	Needle Return Spring		
11	Cylinder Cap (Adjustable)	95-091	
12	Stainless Steel Ball	UH-610	
13	Compression Spring	95-013	
14	Set Screw	UH-691/5	(Pack of 5)
15	Jam Nut	UH-824	
16	Needle Adjustment Screw	95-032	
17	Cylinder Cap (Non-Adjustable)	95-080	
18	O-Ring		
19	Air Manifold	95-030	
20	Set Screw	UH-612/5	(Pack of 5)
21	Flat Head Screw		
22	Air Inlet Fitting		
23	Philips Pan Head Screw		
24	Valve Seal Ball		
26	Fan Valve Body	95-014	
27	O-Ring		
28	Hex Jam Nut		
29	Valve Stem	95-036	
30	Plug	95-077-D	
31	Fluid Inlet Fitting	80-932	
32	Fluid Needle Packing	91-139	
33	Packing Nut	91-023-D	
34	Seal Nut		
35	Teflon® Seal	95-020/2	(Pack of 2)
36	Seal Housing	95-017	
37	O-Ring	UH-647/10	(Pack of 10)
38	Needle Cover	95-102	
39	Cylinder Cap (Adjustable) Assembly	95-040	
40	Fan Control Assembly	95-042	
41	Universal Maintenance Kit	95-043	

Note: For all part numbers with X, see page 37



3M™ Series 56 HVLP Automatic Spray Gun Parts Identification

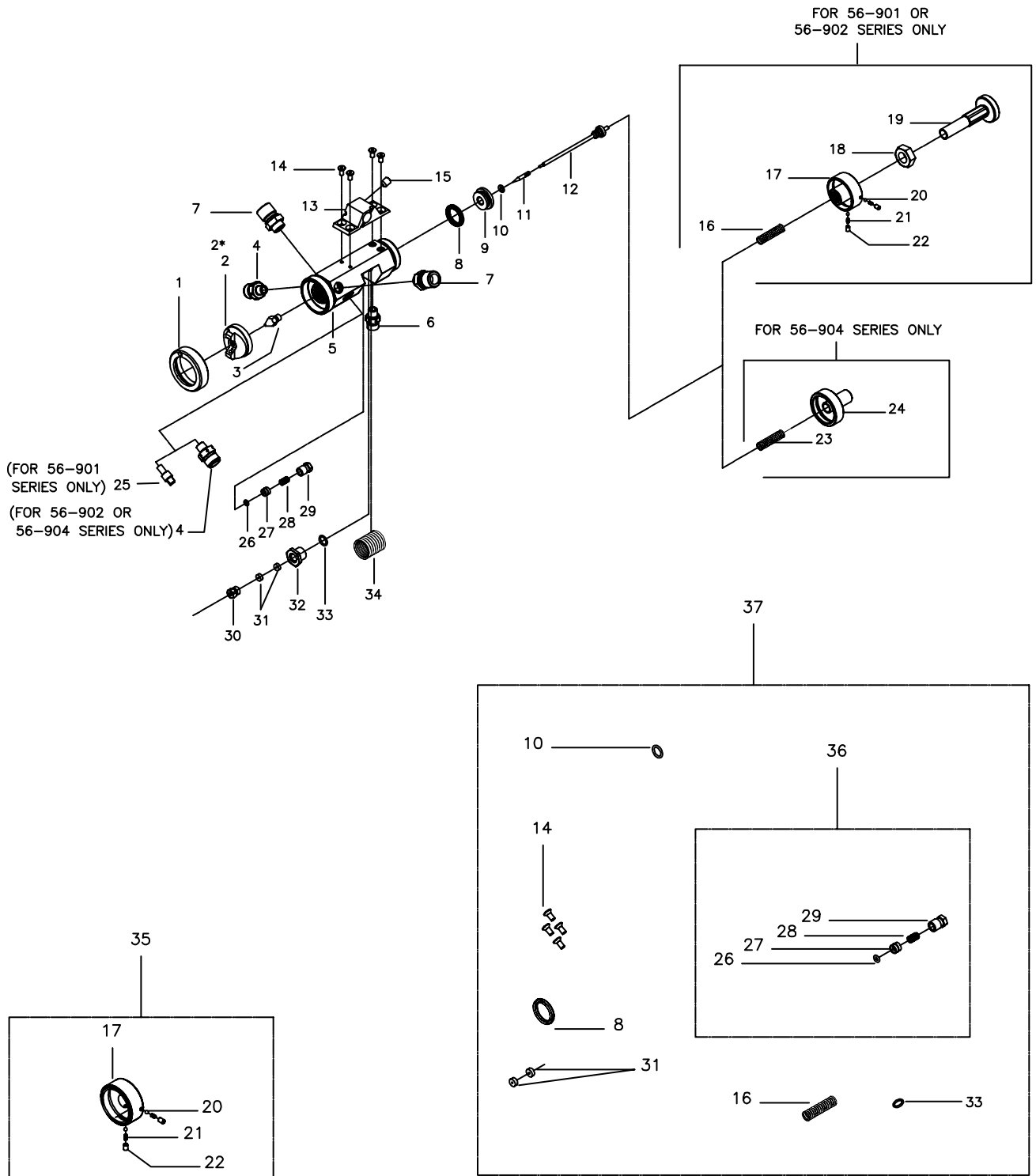

3M™ Series 56 HVLP Automatic Spray Gun Parts Identification

Item	Description	Replacement PN	
1	Retaining Ring	91-043	
2	Air Cap (Composite)	91-009-XXX	
2*	Air Cap (Aluminum)	91-071-XXX	
3	Fluid Nozzle		
4	Fluid Fitting	95-025	
5	Autogun Body Assembly	95-029	
6	Fitting	80-932	
7	Quick Disconnect Fitting	95-038	
8	Cylinder Seal (U-Cup)	95-018	
9	Piston	95-031	
10	O-Ring	UH-768/5	(Pack of 5)
11	Needle Tip (Delrin®)	91-107-XXX/4	(Pack of 4)
12	Needle Shaft	95-033	
13	Mounting Bracket	95-037	
14	Screw		
15	Set Screw	UH-612/5	(Pack of 5)
16	Needle Return Spring		
17	Cylinder Cap (Adjustable)		
18	Jam Nut	UH-824	
19	Needle Adjustment Screw	95-032	
20	Stainless Steel Ball	UH-610	
21	Compression Spring	95-013	
22	Set Screw	UH-691/5	(Pack of 5)
23	Compression Spring		
24	Cylinder Cap (Non-Adjustable)	95-082	
25	Plug	95-077	
26	O-Ring	UH-1405/10	(Pack of 10)
27	Needle Guide		
28	Compression Spring		
29	Packing Nut		
30	Seal Nut	95-016	
31	Teflon® Seal	95-020/2	(Pack of 2)
32	Seal Housing	95-017	
33	O-Ring	UH-647/10	(Pack of 10)
34	Needle Cover	95-102	
35	Cylinder Cap (Adjustable) Assembly	95-040	
36	Fluid Packing Kit	91-200	
37	Universal Maintenance Kit	95-043	

Note: For all part numbers with X, see page 37

* Denotes difference in material



3M™ Series 56ZZ HVLP Automatic Spray Gun Parts Identification

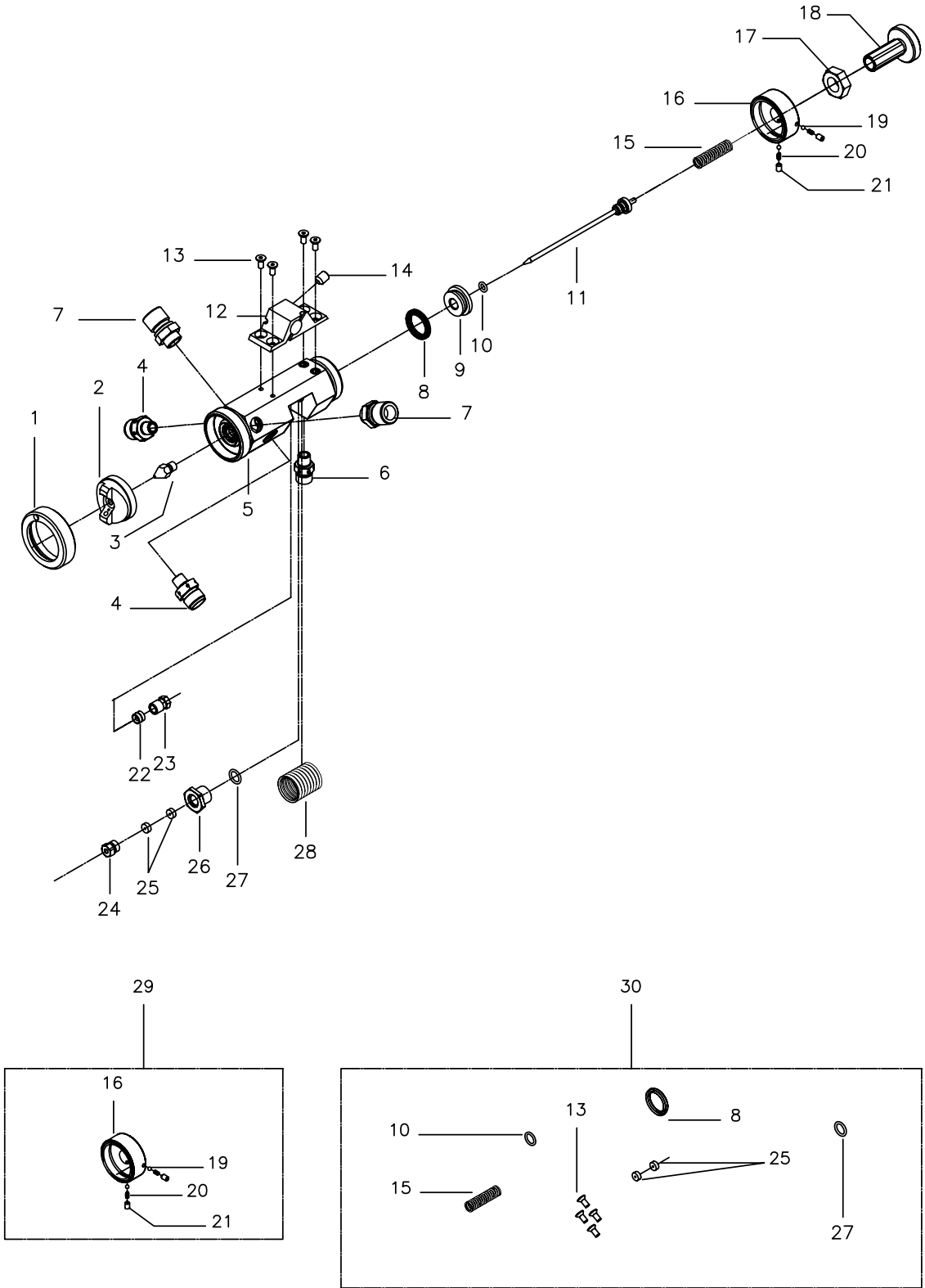

3M™ Series 56ZZ HVLP Automatic Spray Gun Parts Identification

Item	Description	Replacement PN	
1	Retaining Ring	91-043	
2	Air Cap (Composite)	91-009-XXX	
3	Delrin® Fluid Nozzle	91-148-XXX	
4	Fluid Fitting	95-025-D	
5	Autogun Body Assembly	95-029-D	
6	Fitting	80-932	
7	Quick Disconnect Fitting	95-038	
8	Cylinder Seal (U-Cup)	95-018	
9	Piston	95-031	
10	O-Ring	UH-768/5	(Pack of 5)
11	Full Delrin® Needle Assembly	95-048-XXXD	
12	Mounting Bracket	95-037	
13	Screw		
14	Set Screw	UH-612/5	(Pack of 5)
15	Needle Return Spring		
16	Cylinder Cap (Adjustable)		
17	Jam Nut	95-089	
18	Needle Adjustment Screw	95-032	
19	Stainless Steel Ball	UH-610	
20	Compression Spring	95-013	
21	Set Screw	UH-691/5	(Pack of 5)
22	Needle Fluid Packing	91-139	
23	Packing Nut	91-023-D	
24	Seal Nut	95-016-D	
25	Teflon® Seal	95-020/2	(Pack of 2)
26	Seal Housing	95-017	
27	O-Ring	UH-647/10	(Pack of 10)
28	Needle Cover	95-102	
29	Cylinder Cap (Adjustable) Assembly	95-040	
30	Universal Maintenance Kit	95-043	

Note: For all part numbers with X, see page 37



3M™ Series 57 HVLP Automatic Spray Gun Parts Identification

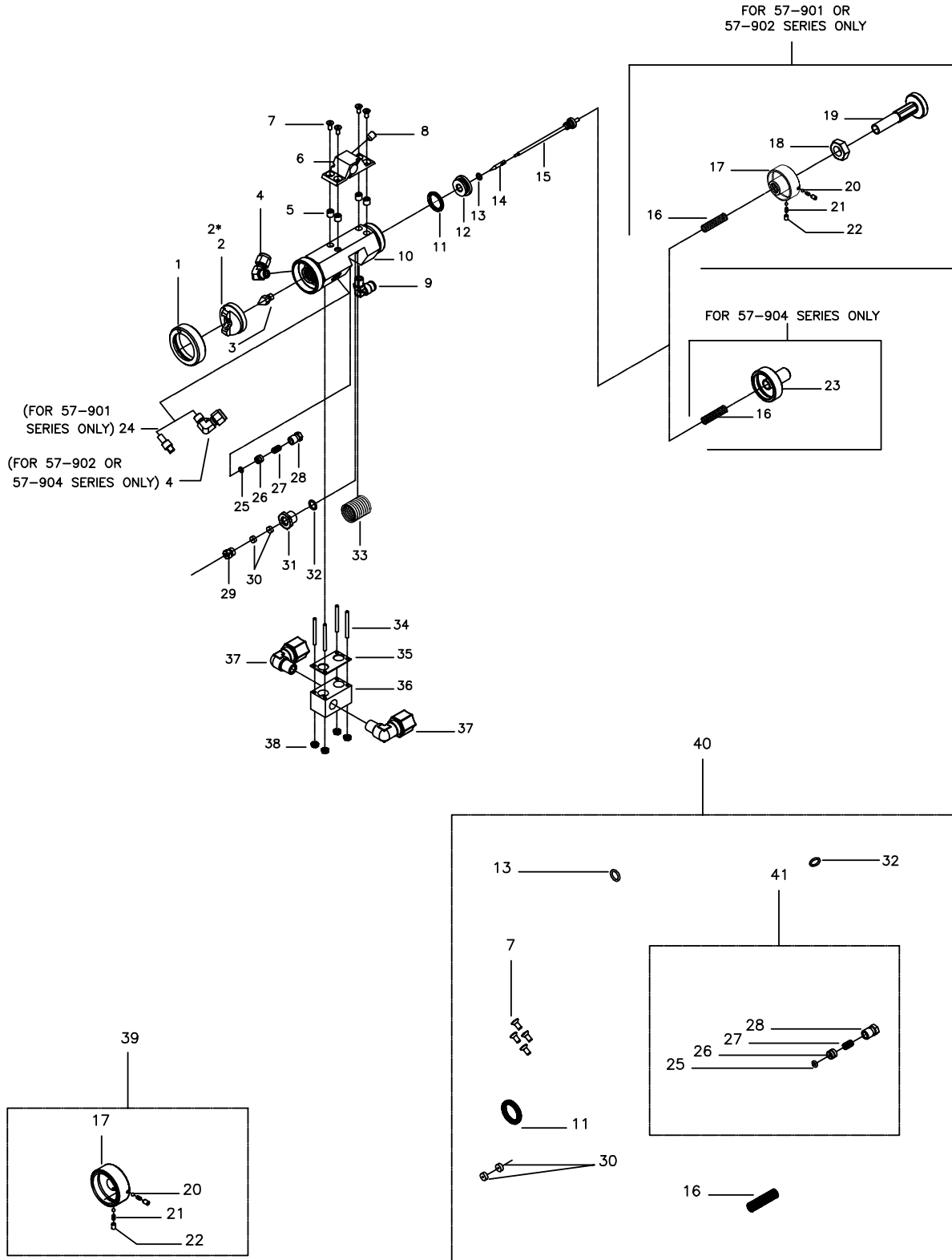

3M™ Series 57 HVLP Automatic Spray Gun Parts Identification

Item	Description	Replacement PN	
1	Retaining Ring	91-043	
2	Air Cap (Composite)	91-009-XXX	
2*	Air Cap (Aluminum)	91-071-XXX	
3	Fluid Nozzle		
4	Fluid Fitting-Elbow	95-SP2-10	
5	Threaded Insert		
6	Mounting Bracket	95-037	
7	Screw		
8	Set Screw	UH-612/5	Pack of 5)
9	Trigger Fitting	95-SP2-8	
10	Autogun Body Assembly	95-SP2-1	
11	Cylinder Seal (U-Cup)	95-018	
12	Piston	95-031	
13	O-Ring	UH-768/5	(Pack of 5)
14	Needle Tip (Delrin®)	91-107-XXX/4	(Pack of 4)
15	Needle Shaft	95-033	
16	Needle Return Spring		
17	Cylinder Cap (Adjustable)		
18	Jam Nut	UH-824	
19	Needle Adjustment Screw	95-032	
20	Stainless Steel Ball	UH-610	
21	Compression Spring	95-013	
22	Set Screw	UH-691/5	(Pack of 5)
23	Cylinder Cap (Non-Adjustable)	95-082	
24	Plug	95-077	
25	O-Ring	UH-1405/10	(Pack of 10)
26	Needle Guide		
27	Compression Spring		
28	Packing Nut		
29	Seal Nut	95-016	
30	Teflon® Seal	95-020/2	(Pack of 2)
31	Seal Housing	95-017	
32	O-Ring	UH-647/10	(Pack of 10)
33	Needle Cover	95-102	
34	Mounting Stud	95-076	
35	Manifold Gasket	95-078	
36	Manifold Block	95-075	
37	Elbow	UH-967	
38	Hex Nut with Lock Washer	UH-911	
39	Cylinder Cap (Adjustable) Assembly	95-040	
40	Universal Maintenance Kit	95-043	
41	Fluid Packing Kit	91-200	

Note: For all part numbers with X, see page 37

* Denotes difference in material



3M™ Series 57ZZ HVLP Automatic Spray Gun Parts Identification

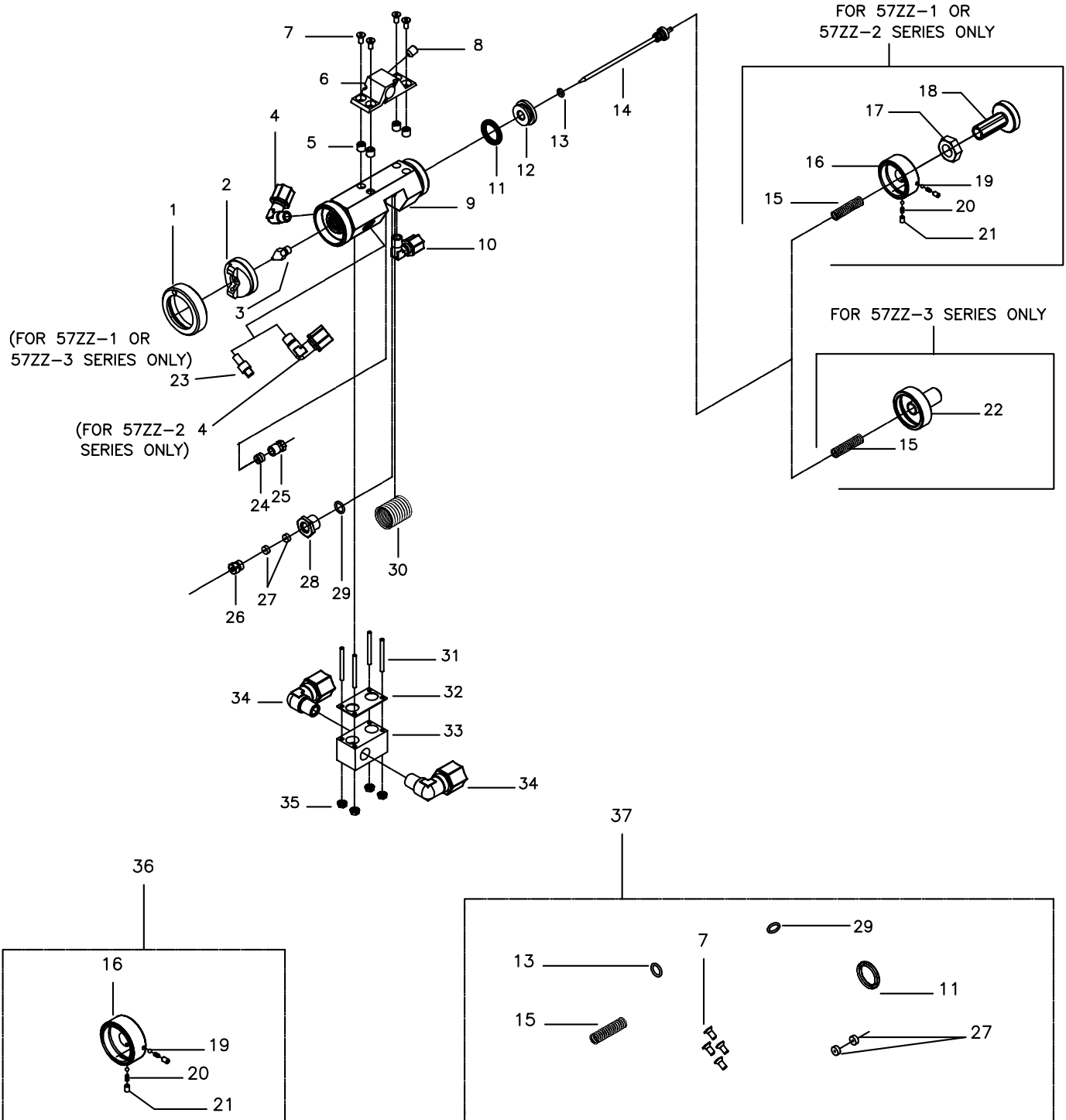

3M™ Series 57ZZ HVLP Automatic Spray Gun Parts Identification

Item	Description	Replacement PN	
1	Retaining Ring	91-043	
2	Air Cap (Composite)	91-009-XXX	
3	Delrin® Fluid Nozzle	91-148-XXX	
4	Fluid Fitting-Elbow		
5	Threaded Insert		
6	Mounting Bracket	95-037	
7	Screw		
8	Set Screw	UH-612/5	(Pack of 5)
9	Autogun Body Assembly	95-083	
10	Trigger Fitting-Elbow		
11	Cylinder Seal (U-Cup)	95-018	
12	Piston	95-031	
13	O-Ring	UH-768/5	(Pack of 5)
14	Full Delrin® Needle Assembly	95-048-XXXD	
15	Needle Return Spring		
16	Cylinder Cap (Adjustable)		
17	Jam Nut	95-089	
18	Needle Adjustment Screw	95-032	
19	Stainless Steel Ball	UH-610	
20	Compression Spring	95-013	
21	Set Screw	UH-691/5	(Pack of 5)
22	Cylinder Cap (Non-Adjustable)	95-080	
23	Plug	95-077-D	
24	Needle Fluid Packing	91-139	
25	Packing Nut	91-023-D	
26	Seal Nut	95-016-D	
27	Teflon® Seal	95-020/2	(Pack of 2)
28	Seal Housing	95-017	
29	O-Ring	UH-647/10	(Pack of 10)
30	Needle Cover	95-102	
31	Mounting Stud	95-076	
32	Manifold Gasket	95-078	
33	Manifold Block	95-075	
34	Elbow	UH-967	
35	Hex Nut with Lock Washer	UH-911	
36	Cylinder Cap (Adjustable) Assembly	95-040	
37	Universal Maintenance Kit	95-043	

Note: For all part numbers with X, see page 37



3M™ Series 57UL HVLP Automatic Spray Gun Parts Identification

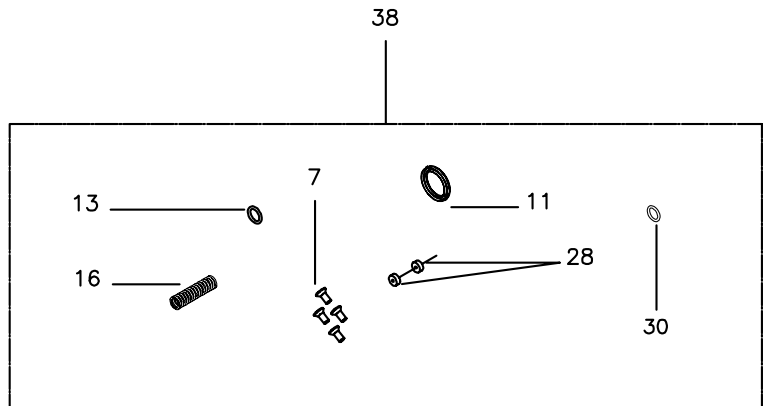
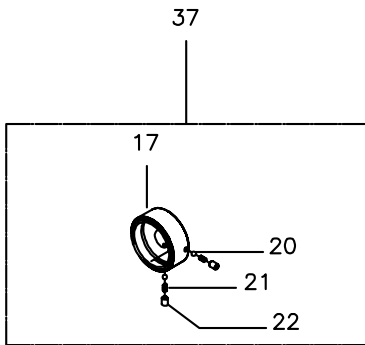
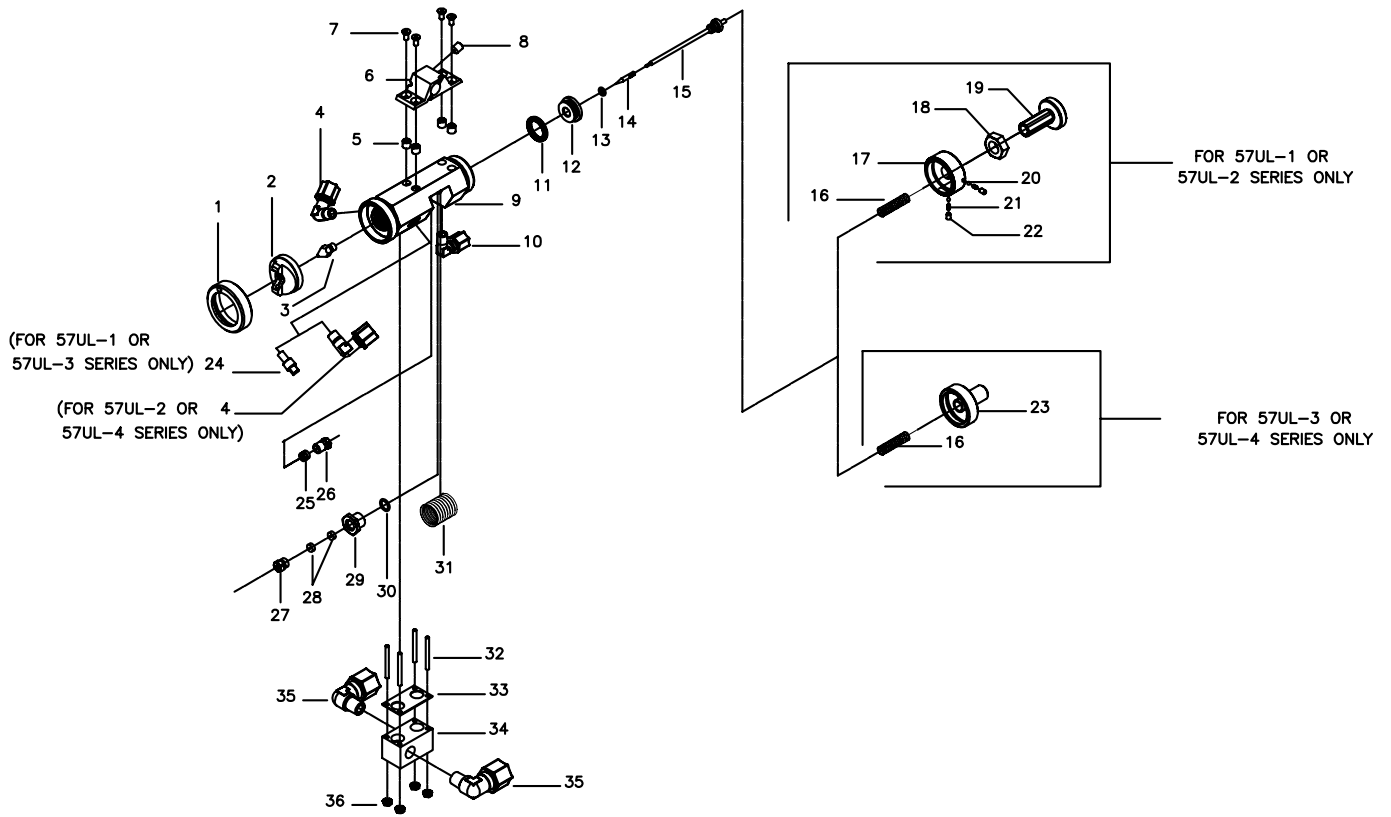

3M™ Series 57UL HVLP Automatic Spray Gun Parts Identification

Item	Description	Replacement PN	
1	Retaining Ring	91-043	
2	Air Cap (Composite)	91-009-XXX	
3	Delrin® Fluid Nozzle	91-148-XXX	
4	Fluid Fitting-Elbow		
5	Threaded Insert		
6	Mounting Bracket	95-037	
7	Screw		
8	Set Screw	UH-612/5	(Pack of 5)
9	Autogun Body Assembly	95-083	
10	Trigger Fitting-Elbow		
11	Cylinder Seal (U-Cup)	95-018	
12	Piston	95-031	
13	O-Ring	UH-768/5	(Pack of 5)
14	Delrin® Needle Tip	91-107-XXX/4	(Pack of 4)
15	Stainless Steel Needle Shaft	95-033	
16	Needle Return Spring		
17	Cylinder Cap (Adjustable)		
18	Jam Nut	95-089	
19	Needle Adjustment Screw	95-032	
20	Stainless Steel Ball	UH-610	
21	Compression Spring	95-013	
22	Set Screw	UH-691/5	(Pack of 5)
23	Cylinder Cap (Non-Adjustable)	95-080	
24	Plug	95-077-D	
25	Needle Fluid Packing	91-139	
26	Packing Nut	91-023-D	
27	Seal Nut	95-016-D	
28	Teflon® Seal	95-020/2	(Pack of 2)
29	Seal Housing	95-017	
30	O-Ring	UH-647/10	(Pack of 10)
31	Needle Cover	95-102	
32	Mounting Stud	95-076	
33	Manifold Gasket	95-078	
34	Manifold Block	95-075	
35	Elbow	UH-967	
36	Hex Nut with Lock Washer	UH-911	
37	Cylinder Cap (Adjustable) Assembly	95-040	
38	Universal Maintenance Kit	95-043	

3M™ Tip/Nozzle/Air Cap Selection Guide

Standard Tip/Nozzle

Size	Description	Replacement PN
.021 (0.5mm)	Replacement Tips	91-107-021/4 (Pack of 4)
	Standard Tip/Nozzle Set	91-143-021DT
.028 (0.7mm)	Replacement Tips	91-107-028/4 (Pack of 4)
	Standard Tip/Nozzle Set	91-143-028DT
.036 (0.9mm)	Replacement Tips	91-107-036/4 (Pack of 4)
	Standard Tip/Nozzle Set	91-143-036DT
.043 (1.1mm)	Replacement Tips	91-107-043/4 (Pack of 4)
	Standard Tip/Nozzle Set	91-143-043DT
.051 (1.3mm)	Replacement Tips	91-107-051/4 (Pack of 4)
	Standard Tip/Nozzle Set	91-143-051DT
.061 (1.5mm)	Replacement Tips	91-107-061/4 (Pack of 4)
	Standard Tip/Nozzle Set	91-143-061DT
.072 (1.8mm)	Replacement Tips	91-107-072/4 (Pack of 4)
	Standard Tip/Nozzle Set	91-143-072DT
.084 (2.0mm)	Replacement Tips	91-107-084/4 (Pack of 4)
	Standard Tip/Nozzle Set	91-143-084DT
.110 (3.0mm)	Replacement Tips	91-107-110/4 (Pack of 4)
	Standard Tip/Nozzle Set	91-143-110DT

Air Cap

Air Cap Number	Description	Replacement PN
2	Aluminum Air Cap	91-071-2
3	Aluminum Air Cap	91-071-3
4	Aluminum Air Cap	91-071-4
5	Aluminum Air Cap	91-071-5
6	Aluminum Air Cap	91-071-6
7	Aluminum Air Cap	91-071-7
8	Aluminum Air Cap	91-071-8
	Composite Air Cap	91-009-8
9	Aluminum Air Cap	91-071-9
	Composite Air Cap	91-009-9
10	Aluminum Air Cap	91-071-10
	Composite Air Cap	91-009-10
11	Aluminum Air Cap	91-071-11
	Composite Air Cap	91-009-11
12	Composite Air Cap	91-009-12
13	Composite Air Cap	91-009-13

3M™ Tip/Nozzle/Air Cap Selection Guide

Size	Description	Replacement PN
.021 (0.5mm)	Full Delrin® Needle Assembly Delrin® Fluid Nozzle	95-048-021D 91-148-021
.028 (0.7mm)	Full Delrin® Needle Assembly Delrin® Fluid Nozzle	95-048-028D 91-148-028
.036(0.9mm)	Full Delrin® Needle Assembly Delrin® Fluid Nozzle	95-048-036D 91-148-036
.043 (1.1mm)	Full Delrin® Needle Assembly Delrin® Fluid Nozzle	95-048-043D 91-148-043
.051 (1.3mm)	Full Delrin® Needle Assembly Delrin® Fluid Nozzle	95-048-051D 91-148-051
.061 (1.5mm)	Full Delrin® Needle Assembly Delrin® Fluid Nozzle	95-048-061D 91-148-061
.072 (1.8mm)	Full Delrin® Needle Assembly Delrin® Fluid Nozzle	95-048-072D 91-148-072
.084 (2.0mm)	Full Delrin® Needle Assembly Delrin® Fluid Nozzle	95-048-084D 91-148-084

Troubleshooting

Problem	Cause	Remedy
Bad Spray Pattern	Air cap or nozzle clogged	Clean with appropriate solvent
	Bent fluid needle	Replace fluid needle
Blistering	Moisture on surface	Clean surface
	Wrong solvent	Check solvent
	Coats not compatible	Check material compatibility
	Insufficient dry time	Longer dry time
	Surface too cold	Warm surface
Fish Eyes	Air contamination	Add air filtration
	Silicone contamination	Clean surface with solvent
Heavy Middle Pattern	Too much fluid pressure	Reduce fluid pressure
	Not enough atomizing pressure	Increase atomizing pressure
Intermittent Pulsating Spray	Worn or loose packing	Tighten or replace
	Low fluid pressure	Add fluid or increase fluid pressure
Insufficient Fluid Flow, Pressure Feed	Restriction in fluid line Blocked hose	Use 3/8" fluid hose Flush or replace hose
	Fluid nozzle too small	Use larger needle/nozzle
	Low fluid pressure	Increase fluid pressure
Coarse or Lumpy Surface	Dirt or dust on surface	Tack wipe before spray
	Material is contaminated	Change or strain
Mottled Looking Surface	Coating too thin	Use less thinner
	Coats too wet	Use less thinner
	Improper spray technique	Ensure gun is parallel to work
No Paint Flow	Clogged fluid nozzle	Clean fluid nozzle
	Loss of fluid pressure	Out of paint
	Clogged air passage	Clean with solvent
	Restriction in mat'l hose	Flush with solvent
	Clogged check valve	Replace check valve
Orange Peel	Paint drying too fast	Use proper solvent
	Gun too far from target	6-8 inches is ideal
	Viscosity too high	Reduce with solvent
Overspray is Excessive	Gun too far from target	6-8 inches is ideal
	Too much atomizing air for coating being sprayed	Reduce atomizing air
Pin-Holing, Solvent Pops	Trapped solvent	Apply lighter coats
	Improper solvent	Check coating manufacturer
	System contaminated	Clean all parts
Paint Leak	Wrong needle size	Replace
	Damaged-worn needle	Replace
	Loose fluid nozzle	Tighten or replace
	Worn/loose packing nut	Tighten or replace
	Needle not closing	Packing too tight. Broken or missing needle spring. Dried paint on needle.
	Loose fluid fitting	Tighten or replace

Spray Equipment Warranty and Limited Remedy

3M™ warrants to the original purchaser that, when used in accordance with 3M's written instructions, 3M spray equipment will be free of defects in materials and manufacture for one year from the date of purchase. This warranty does not apply to damage or malfunction caused by normal wear, failure to maintain, or by any abuse, accident, tampering, alteration, or misuse of the spray equipment.

To make a claim under the warranty, you must first contact the 3M service center at 1-877-MMM-CARS to receive a return authorization number. Spray equipment must be returned, freight prepaid by the purchaser, to the service location address given by the 3M service center. Upon validation of the warranty claim, 3M will replace or repair the spray gun, at 3M's option, and return it to the purchaser at 3M's expense, including parts, labor and return shipping charges. If it is determined that the claim is not covered by the warranty, the purchaser will be given the option to have the spray gun repaired outside of the warranty. An estimate of parts and labor will be provided by 3M and must be approved by the purchaser in advance.

Except as written above, 3M MAKES NO OTHER EXPRESS OR IMPLIED WARRANTIES OR CONDITIONS, INCLUDING BUT NOT LIMITED TO ANY IMPLIED WARRANTY OR CONDITION OF MERCHANTABILITY OR FITNESS FOR A PARTICULAR PURPOSE. The purchaser is responsible for determining whether the 3M spray equipment is fit for any particular purpose intended.

Limitation of Liability: The remedies set forth above are exclusive. Except where prohibited by law, 3M and any seller of the spray equipment will not be liable for any loss or damage arising from or related to the use or inability to use this product, whether direct, indirect, special, incidental or consequential, regardless of the legal theory or basis of liability asserted.

Contact Information

TO PLACE AN ORDER, contact your 3M Sales Representative or Distributor, or call this number:
1-877-MMM-CARS
(1-877-666-2277)

All written and visual data contained in this document reflects the latest product information available at the time of publication.
3M reserves the right to make changes at any time without notice.

3M Automotive Aftermarket Division

31100 Solon Road, Bldg. B
Solon, OH 44139-3462
www.3M.com

PRINTED IN U.S.A. ©3M 2008. All Rights Reserved.

3M is a trademark of 3M Company.

Teflon® and Delrin® are registered trademarks of E.I. du Pont de Nemours and Company.

Revision A

34-8701-7283-9



DO NOT PRINT THIS PAGE

Contact: Correen Rosenberger

Creator: deZinnia

Spec # 34-8701-7283-9

Structure: SS-19907

Inks: Black

Date: 9/05/08

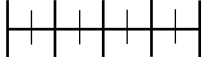
Scale:  1 Inch

All Prints BLACK

This artwork has been created as requested by 3M. 3M is responsible for the artwork AS APPROVED and assumes full responsibility for its correctness.