

Preliminary Technical Information

SMV SmartLine Multivariable Transmitter Specification 34-SM-03-92, October 2015



Introduction

The SMV 800 combines sensor technologies for differential pressure, static pressure and temperature with the latest microprocessor technology to provide highly accurate compensated flow measurement. When paired with the other SmartLine unique features the SMV 800 delivers the highest levels of safety, reliability and efficiency available. The SmartLine family is also fully tested and compliant with Experion[®] PKS providing the highest level of compatibility assurance and integration capabilities.

Best in Class Features:

- Accuracy up to 0.0400% for Differential pressure
- Accuracy up to 0.0375% for Static pressure
- Accuracy up to 0.1 Deg C for Temperature
- Mass Flow Reference Accuracy: up to 0.6%
- Automatic static pressure & temperature compensation
- Rangeability up to 400:1
- Compensated flow response time of up to 2x per second
- Multiple local display capabilities
- External zero, span, & configuration capability
- Polarity insensitive electrical connections
- Comprehensive on-board diagnostic capabilities
- Integral Dual Seal design for highest safety based on ANSI/NFPA 70-202 and ANSI/ISA 12.27.0
- World class overpressure protection
- Modular design characteristics

Span & Range Limits:

Model	URL	LRL	Max Span	Min Span
PV1 - DP	"H ₂ O (mbar)	"H ₂ O (mbar)	"H ₂ O (mbar)	"H ₂ O (mbar)
SMA810	25 (62.50)	-25 (-62.5)	25 (62.50)	1.0 (2.5)
SMA845	400 (1000)	-400 (-1000)	400 (1000)	1.0 (2.5)
SMG870	400 (1000)	-400 (-1000)	400 (1000)	1.0 (2.5)
PV2 - SP	psiA (bara)	psiA (bara)	psiA (bara)	psiA (bar)
SMA810	100 (7.0)	0 (0)	100 (7.0)	5 (0.35)
SMA845	1500 (104)	0 (0)	1500 (104)	30 (2.1)
PV2 - SP	psig (barg)	psig (barg)	psig (barg)	psig (barg)
SMG870	4500 (310)	-14.7 (-1)	4500 (310)	60 (4.2)



Figure 1 – SMV 800 Multivariable Transmitters feature field-proven piezoresistive sensor technology

Communications/Output Options:

- 4-20mA DC (Analog)
- Honeywell Digitally Enhanced (DE) Single or Multivariable
- HART[®] (version 7.0)

All transmitters are available with the above listed communication protocols.

Description

Honeywell's SMV 800 Smart Multivariable Flow Transmitter extends our proven "smart" technology to the measurement of three separate process variables with the ability to calculate compensated mass or volume flow rate as a fourth process variable according to industry standard methods for air, gases, steam and liquids.

Unique Indication/Display

Advanced Graphics LCD Display Features

- Modular (may be replaced in the field)
- 0, 90, 180, & 270 degree position adjustments
- Standard and custom measurement units available.
- Up to eight display screens with 3 formats are possible (Large PV with Bar Graph or PV with Trend Graph)
- Configurable screen rotation timing (3 to 30 sec)
- Display Square Root capabilities may be set separately from the 4-20mA dc output signal
- Multiple language capability. (EN, GE, FR, IT, SP, RU, TU, CH, & JP)

Diagnostics

SmartLine transmitters all offer digitally accessible diagnostics which aid in providing advanced warning of possible failure events minimizing unplanned shutdowns, providing lower overall operational costs

Configuration Tools

Integral Three Button Configuration Option

Suitable for all electrical and environmental requirements, SmartLine offers the ability to configure the transmitter and display via three externally accessible buttons except for the flow related parameters. Zero/span capabilities are also optionally available via these buttons with or without selection of a display option.

Hand Held Configuration

SmartLine transmitters feature two-way communication and configuration capability between the operator and the transmitter. This is accomplished via Honeywell's field-rated Multiple Communication Configurator (MCT404). The MCT404 is capable of field configuring HART SMV Devices, for all parameters other than flow configuration, can be ordered for use in intrinsically safe environments. All Honeywell transmitters are designed and tested for compliance with the offered communication protocols and are designed to operate with any properly validated hand held configuration device.

Measurement Types:

SMV is capable of mass flow measurements for liquids, gases, and superheated and saturated steam.

Personal Computer Configuration

Honeywell's PC Based configuration Toolkit SCT3000 provides an easy way to configure the SMV800 DE devices.

SMV800 HART Device can be configured using Device Description based DCs Hosts and Asset Management Systems. HART device can also be configured using PC based DTMs. DTMs provide enhanced features like:

- Easy to use Flow Configuration
- Units Preference: Configurable Engineering units
- Auto Calculation of Viscosity and Density Coefficients, Auto Calculation of K User, Beta Factor
- Export and Import Configurations to/from external file with predefine schema/format
- Summary Page

Primary Element Compatibility

Flow: The SMV is compatible with and provides dynamic calculation capabilities for the following primary flow elements:

- Orifice Plates (ASME MFC-3M & AGA No 3/ISO 5167/GOST 8.586).
- Integral Orifice
- Small Bore Orifice (ASME MFC -14M)
- Conditional Orifice (ISO5167-2003)
- Nozzles (ASME MFC-3M/ISO 5167/GOST 8.586).
- Venturi Tubes (ASME MFC-3M/ISO 5167/GOST).
- Averaging Pitot Tubes
- V-Cone[®], Wafer Cone, Wedge

Fixed Parameters: Fixed Cd, Y1, Viscosity, Density are supported for user to customize the flow calculation

Temperature: The SMV also has the following temperature input options:

- **RTD** (2,3,4 wires): PT25, PT100, PT200, PT500, PT1000
- **Universal Input:** RTD PT25, PT100, PT200, PT500, PT1000 and **Thermocouple:** Type B, E, J, K, N, R, S, T

Mass Flow Calculation

Mass Flow Compensation can be selected for Standard Compensations by user for Gas, Liquid and Steam without limitation on primary elements.

Mass Flow Compensation can be selected for Dynamic Compensation by the user from: ASME-MFC-3M, ISO5167, Gost-8.586, for Orifice Plate, Nozzle and Venturri, AGA3 for Orifice, and Calculation Support for Averaging Pitot Tube, VCone, Wafer Cone, Wedge and Integral Orifice and Conditional Orifice are also available. Mass Flow Calculations also support user Fixed Input Parameters for Customizing the Calculations.

System Integration

- SmartLine communications protocols all meet the most current published standards for HART/DE
- Integration with Honeywell's Experion PKS offers the following unique advantages.
 - Messaging & Maintenance Mode Indication
 - Tamper reporting
 - FDM Plant Area Views with Health summaries
 - All SMV 800 units are Experion tested to provide the highest level of compatibility assurance

Automatic Density Compensation

Using the configuration software, the SMV can be configured with the primary element type and the physical parameters of the fluid measured. This method dynamically compensates for fluid characteristics such as discharge coefficients, gas expansion factors, density, and viscosity as well as installation issues like upstream pipe size using the above referenced algorithms.

Basic Flow Density Compensation

This conventional calculation method is based on flow factors being manually entered

Modular Design

To help contain maintenance & inventory costs, all SMV 800 transmitters are modular in design supporting the user's ability to replace meter bodies, indicators or change electronic modules without affecting overall performance or approval body certifications. Each meter body is uniquely characterized to provide in-tolerance performance over a wide range of application variations in temperature and pressure and due to the Honeywell advanced interface, electronic modules may be swapped without losing in-tolerance performance characteristics.

Modular Features

- Meter body replacement
- Replaceable electronics/comm modules*
- Add or remove integral indicators*
- Add or remove lightning protection (terminal connection)*

* Field replaceable in all electrical environments (including IS) except flameproof without violating agency approvals.

See [Model Selection Guide](#)

With no performance effects, Honeywell's unique modularity results in lower inventory needs and lower overall operating costs.

Performance Specifications

Digital Reference Accuracy² (conformance to +/-3 Sigma)

TABLE I

	Model	URL	LRL	Min Span	Maximum Turndown Ratio	Stability (% URL/Year)	Reference Accuracy ¹ (% Span)
PV1 Differential	SMA810	25 in H ₂ O/62.5mbar	-25 in H ₂ O/-62.5mbar	1 in H ₂ O/2.5mbar	25:1	1.0	0.0400
	SMA845	400 in H ₂ O/1000mbar	-400 in H ₂ O/-1000mbar	1 in H ₂ O/2.5mbar	400:1	0.0625	
	SMG870						
PV2 Static	SMA810	100 psiA/7 bara	0 psiA/0 bara	5 psiA/0.35 bara	20:1	0.125	0.0375
	SMA845	1500 psiA/104 bara	0 psiA/0 bara	30 psiA/2.1 bara	50:1	0.008	
	SMG870	4500 psig/310 barg	-14.7 psig/-1.0 barg	60 psig/4.2 barg	75:1	0.025	

Zero and span may be set anywhere within the listed (URL/LRL) range limits

Digital Accuracy at Specified Span, Temperature and Static Pressure

(Combined Zero & Span, conformance to +/-3 Sigma)

TABLE II

	Model	URL	Accuracy ¹ (% of Span)			Temperature Effect (% Span/50°F)		Static Line Pressure Effect (% Span/1000psi) ³		
			For Spans Below	A	B	C	D	E	F	G
PV1 Differential	SMA810	25 in H ₂ O	1:1	0.015	0.025	25	0.100	0.1000	0.180	0.080
	SMA845	400 in H ₂ O	16:1				0.075	0.0250	0.200	0.025
	SMG870	400 in H ₂ O	16:1							
PV2 Static	SMA810	100psiA	2:1	0.0125	0.025	50	0.05	0.0500	n/a	
	SMA845	1500psiA	10:1			150	0.055	0.0200		
	SMG870	4500psig	10:1			450				
Turn Down Effect						Temp Effect		Static Effect ³		
± $\left[A + B \left(\frac{C}{\text{Span}} \right) \right]$						± $\left[D + E \left(\frac{\text{URL}}{\text{Span}} \right) \right]$		± $\left[F + G \left(\frac{\text{URL}}{\text{Span}} \right) \right]$		
% Span						% Span per 28°C (50°F)		% Span per 1000 psi		

Typical Calibration Frequency:

PV1 and PV2 calibration verification is recommended every four (4) years

Notes:

¹ Digital terminal based accuracy – Includes the combined effects of linearity, hysteresis and repeatability. Analog output adds 0.005% of span error.

² For zero based spans and reference conditions of 25°C (77°F), 0 static pressure, 10 to 55% RH and 316SS barrier diaphragm.

³ Static Line Pressure effect for SMA810 is % span/25 psi

Performance Specifications

Digital PV3 Temperature Reference Accuracy ² (conformance to +/-3 Sigma)

Table III

Input Type	Maximum Range Limits		Digital Accuracy (+/-) ¹	Min Span	Stability (% ULR/year)	Standards
RTD (2,3,4 wire)	°C	°F	°C	°C	%	
Pt25	-200 to 850	-328 to 1562	0.50	1.0	0.01	IEC751:1990 ($\alpha=0.00385$)
Pt100	-200 to 850	-328 to 1562	0.10	1.0	0.01	IEC751:1990 ($\alpha=0.00385$)
Pt200	-200 to 850	-328 to 1562	0.20	1.0	0.01	IEC751:1990 ($\alpha=0.00385$)
Pt500	-200 to 850	-328 to 1562	0.12	1.0	0.01	IEC751:1990 ($\alpha=0.00385$)
Pt1000 ⁴	-200 to 500	-328 to 932	0.10	1.0	0.01	IEC751:1990 ($\alpha=0.00385$)
Thermo-couples³	°C	°F	°C			
B	200 to 1820	392 to 3308	0.60	1.0	0.01	IEC 584-1 (ITS-90)
E	-200 to 1000	-328 to 1832	0.20	1.0	0.01	IEC 584-1 (ITS-90)
J	-200 to 1200	-328 to 2192	0.25	1.0	0.01	IEC 584-1 (ITS-90)
K	-200 to 1370	-328 to 2498	0.25	1.0	0.01	IEC 584-1 (ITS-90)
N	-200 to 1300	-328 to 2372	0.40	1.0	0.01	IEC 584-1 (ITS-90)
R	-50 to 1760	-58 to 3200	0.50	1.0	0.01	IEC 584-1 (ITS-90)
S	-50 to 1760	-58 to 3200	0.50	1.0	0.01	IEC 584-1 (ITS-90)
T	-250 to 400	-418 to 752	0.20	1.0	0.01	IEC 584-1 (ITS-90)

Notes:

1. Digital Accuracy is accuracy of the digital value accessed by the Host system and the handheld communicator
2. Analog Output Accuracy is applicable to the 4 to 20 mA Signal output
3. For TC inputs, CJ accuracy of 0.25°C shall be added to digital accuracy to calculate the total digital accuracy
4. These input types are not available on DE units

Total analog accuracy is the sum of digital accuracy and 0.005% of span.

Ambient Temperature Effect Digital Accuracy: For RTD Inputs, 0.0015°C/°C/. For T/C Inputs: 0.005°C/°C

Output D/A: 0.0005% of span/°C

PV4 Mass Flow Reference Accuracy: 0.6% over 20:1 flow range, calculated every 500ms^{1,2}

¹ Flow performance specifications assume dynamic compensation and is applicable for SMA845 and SMG870

² Applicable standards and installations per ASME MFC 3M or ISO 5167-1 for un-calibrated orifice; Bigger than 2.8 inch Pipe Diameter; (0.2 < beta < 0.6 Orifice). DP Turn down 16:1; Reference accuracy does not include RTD sensor accuracy.

Operating Conditions – All Models

Parameter	Reference Condition		Rated Condition		Operative Limits		Transportation and Storage	
	°C	°F	°C	°F	°C	°F	°C	°F
Ambient Temperature¹ SMA810, SMA845, SMG870	25±1	77±2	-40 to 85	-40 to 185	-40 to 85	-40 to 185	-55 to 120	-67 to 248
Meter Body Temperature² SMA810, SMA845, SMG870	25±1	77±2	-40 to 110 ¹	-40 to 230 ¹	-40 to 125	-40 to 257	-55 to 120	-67 to 248
Humidity %RH	10 to 55		0 to 100		0 to 100		0 to 100	
Vac. Region – Min. Pressure mmHg absolute inH₂O absolute	Atmospheric Atmospheric		25 13		2 (short term) ³ 1 (short term) ³			
Supply Voltage Load Resistance	HART Models: 10.8 to 42.4 Vdc at terminals (IS version limited to 30v) 0 to 1440 ohm (as shown in Figure 2) DE Models: 15V to 42.4 Vdc at terminals (IS version limited to 30V, XP and Non Sparking/ Non Incentive, 42 Volts.) 0 to 900 ohm (as shown in Figure 2)							
Maximum Allowable Working Pressure (MAWP)^{4,5} (SMV 800 products are rated to Maximum Allowable Working Pressure. MAWP depends on Approval Agency and transmitter materials of construction.)	Standard: SMA810 = 100 psiA, 7.0 BarA SMA845 = 1500 psiA, 104 BarA SMG870 = 4500 psiG, 310 BarG							

¹ LCD Display operating temperature -20 °C to +70 °C (-4 °F to 158 °F) . Storage temperature -30 °C to 80 °C (-22 °F to 176 °F).

² For CTFE fill fluid, the rating is -15 to 110 °C (5 to 230 °F)

³ Short term equals 2 hours at 70 °C (158°F)

⁴ MAWP applies for temperatures -40 °C to 125 °C (-40 °F to 257 °F). Static Pressure Limit is de-rated to 3,000 psi (207 BarA) for -26°C to -40°C (-14.8 °F to -40 °F). Use of graphite o-rings de-rates transmitter to 3,625 psi. Use of ½” - process adaptors with graphite o-rings de-rates transmitter to 3,000 psi.

⁵ Consult factory for MAWP of SMV 800 transmitters with CRN approval.

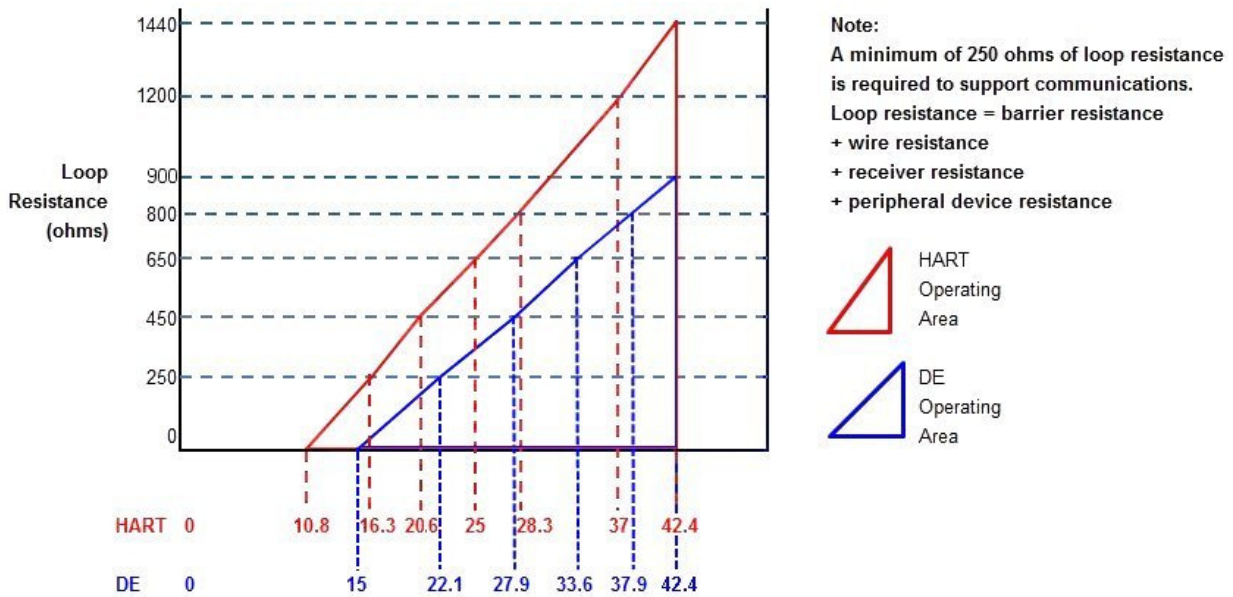

For DE, $R_{max} = 35 * (\text{Power Supply Voltage} - 15)$
 For HART, $R_{max} = 45.6 * (\text{Power Supply Voltage} - 10.8)$

Figure 2 - Supply voltage and loop resistance chart & calculations (HART/DE Protocols)

Performance Under Rated Conditions – All Models

Parameter	Description												
Analog Output Digital Communications:	Two-wire, 4 to 20 mA (HART & DE Transmitters only) Honeywell DE, HART 7 protocol or FOUNDATION Fieldbus ITK 6.0.1 compliant All transmitters, irrespective of protocol have polarity insensitive connection.												
Output Failure Modes	<table border="0"> <tr> <td></td> <td style="text-align: center;">Honeywell Standard:</td> <td style="text-align: center;">NAMUR NE 43</td> </tr> <tr> <td>Compliance:</td> <td></td> <td></td> </tr> <tr> <td>Normal Limits:</td> <td style="text-align: center;">3.8 – 20.8 mA</td> <td style="text-align: center;">3.8 – 20.5 mA</td> </tr> <tr> <td>Failure Mode:</td> <td style="text-align: center;">≤ 3.6 mA and ≥ 21.0 mA</td> <td style="text-align: center;">≤ 3.6 mA and ≥ 21.0 mA</td> </tr> </table>		Honeywell Standard:	NAMUR NE 43	Compliance:			Normal Limits:	3.8 – 20.8 mA	3.8 – 20.5 mA	Failure Mode:	≤ 3.6 mA and ≥ 21.0 mA	≤ 3.6 mA and ≥ 21.0 mA
	Honeywell Standard:	NAMUR NE 43											
Compliance:													
Normal Limits:	3.8 – 20.8 mA	3.8 – 20.5 mA											
Failure Mode:	≤ 3.6 mA and ≥ 21.0 mA	≤ 3.6 mA and ≥ 21.0 mA											
Supply Voltage Effect	0.005% span per volt.												
Transmitter Turn on Time (includes power up & test algorithms)	HART or DE: 5.0 sec.												
Response Time (DP) (delay + time constant)	DE/HART Analog Output: 144mS												
Damping Time Constant	<p>HART DP/SP: Adjustable from 0 to 32 seconds in 0.1 increments. Default: 0.50 seconds</p> <p>HART Temperature: Damping limit is 0 to 102</p> <p>HART FLOW: Damping limit is 0 to 100</p> <p>DE DP/SP: 0, 0.16, 0.32, 0.48, 1, 2, 4, 8, 16, 32 seconds. Default: 0.48 seconds</p> <p>DE for Temperature PV: Damping time 0, 0.3, 0.7, 1.5, 3.1, 6.3, 12.7, 25.5, 51.1, 102.3</p> <p>DE for Flow PV: Damping time 0, 0.50, 1, 2, 3, 4, 5, 10, 50, 100</p>												
Vibration Effect SMA845, SMG870	Less than +/- 0.1% of URL w/o damping Per IEC60770-1 field or pipeline, high vibration level (10-2000Hz: 0.21 displacement/3g max acceleration)												
Electromagnetic Compatibility	EN 61326-1												
Isolation	2000 Vdc (1400Vrms) Galvanic Isolation between inputs and outputs												
Maximum Lead Wire Resistance	Thermocouples: 50 ohms/leg Pt100, Pt200, Pt500 and Pt1000 RTDs: 50 ohms/leg Pt25 RTD: 10 ohms per leg												
Ambient Temperature Effect	Digital Accuracy: For RTD Inputs, 0.0015 °C/°C For T/C Inputs: 0.005 °C/°C												
Temperature Sensor Burnout	Burnout detection is user selectable. Upscale or down scale with critical status message. For RTD type inputs; broken wire/wires will be indicated												
Lightning Protection Option	<p>Leakage Current: 10uA max @ 42.4VDC 93C</p> <p>Impulse rating:</p> <table border="0"> <tr> <td style="padding-right: 20px;">8/20uS</td> <td style="padding-right: 20px;">5000A (>10 strikes)</td> <td>10000A (1 strike min.)</td> </tr> <tr> <td>10/1000uS</td> <td>200A (> 300 strikes)</td> <td></td> </tr> </table>	8/20uS	5000A (>10 strikes)	10000A (1 strike min.)	10/1000uS	200A (> 300 strikes)							
8/20uS	5000A (>10 strikes)	10000A (1 strike min.)											
10/1000uS	200A (> 300 strikes)												

Materials Specifications

(See model selection guide for availability/restrictions with various models)

Parameter	Description
Barrier Diaphragms Material	316L SS, Hastelloy [®] C-276 ² , Monel [®] 400 ³ , Tantalum, Gold-plated 316L SS, Gold-plated Hastelloy [®] C-276, Gold-plated Monel [®] 400
Process Head Material	316 SS ⁴ , Carbon Steel (Zinc-plated) ⁵ , Hastelloy C-276 ⁶ , Monel 400 ⁷
Vent/Drain Valves & Plugs ¹	316 SS ⁴ , Hastelloy C-276 ² , Monel 400 ⁷
Head Gaskets	Glass-filled PTFE standard. Viton [®] and graphite are optional.
Meter Body Bolting	Carbon Steel (Zinc plated) standard. Options include 316 SS, NACE A286 SS bolts, Monel K500, Super Duplex and B7M.
Optional Adapter Flange and Bolts	Adapter Flange materials include 316 SS, Hastelloy C-276 and Monel 400. Bolt material for flanges is dependent on process head bolts material chosen. Standard adaptor o-ring material is glass-filled PTFE. Viton and graphite are optional.
Mounting Bracket	Carbon Steel (Zinc-plated), 304 Stainless Steel or 316 Stainless Steel
Fill Fluid	Silicone Oil DC200, Silicone Oil 704, NEOBEE [®] M-20 or CTFE (Chlorotrifluoroethylene).
Electronic Housing	Pure Polyester Powder Coated Low Copper (<0.4%)-Aluminum. Meets Type 4X, IP66, & IP67. All stainless steel housing is optional.
Mounting	Can be mounted in virtually any position using the standard mounting bracket. Bracket is designed to mount on 2-inch (50 mm) vertical or horizontal pipe. See Figure 4 .
Process Connections	1/4"- NPT or 1/2"- NPT with adapter (meets DIN requirements)
Wiring	Accepts up to 16 AWG (1.5 mm diameter).
Dimensions	See Figure 5 .
Net Weight	8.3 pounds (3.8 Kg). With Aluminum Housing

¹ Vent/Drains are sealed with Teflon[®]

² Hastelloy C-276 or UNS N10276

³ Monel 400 or UNS N04400

⁴ Supplied as 316 SS or as Grade CF8M, the casting equivalent of 316 SS.

⁵ Carbon Steel heads are zinc-plated and not recommended for water service due to hydrogen migration. For that service, use 316 stainless steel wetted Process Heads.

⁶ Hastelloy C-276 or UNS N10276. Supplied as indicated or as Grade CW12MW, the casting equivalent of Hastelloy C-276

⁷ Monel 400 or UNS N04400. Supplied as indicated or as Grade M30C, the casting equivalent of Monel 400

Communications Protocols & Diagnostics

HART Protocol

Version:

HART 7

Power Supply

Voltage: 10.8 Vdc to 42.4 Vdc at terminals

Load: Maximum 1440 ohms See [Figure 2](#).

Minimum Load: 0 ohms. (For handheld communications a minimum load of 250 ohms is required)

Standard Diagnostics

SMV 800 top level diagnostics are reported as either critical or non-critical and readable via the DD/DTM tools or integral display as shown below.

Critical Diagnostics	
HART DD/DTM Tools	Display
<ul style="list-style-type: none"> • Sensor Critical Fault 	<ul style="list-style-type: none"> • Meter Body and/or • Meter Body Comm and/or • Temp Sense Board and/or • Temp Input and/or • Temp Sensor Comm
<ul style="list-style-type: none"> • SIL Diag Failure or • msp vcc fault and/or • Config Data Corrupt • DAC Failure 	<ul style="list-style-type: none"> • Comm Module
<ul style="list-style-type: none"> • DAC Failure 	<ul style="list-style-type: none"> • Comm Module Temp
<ul style="list-style-type: none"> • msp vcc fault 	<ul style="list-style-type: none"> • msp vcc fault

Honeywell Digitally Enhanced (DE)

DE is a Honeywell proprietary protocol which provides multivariable DE communications between Honeywell DE enabled field devices and Hosts.

Power Supply

Voltage: 15 Vdc to 42.4 Vdc at terminals

Load: Maximum 900 ohms See [Figure 2](#).

Non-critical Diagnostics	
HART DD/DTM Tools	Display
<ul style="list-style-type: none"> • Local Display 	<ul style="list-style-type: none"> • Display Setup
<ul style="list-style-type: none"> • Fixed Current Mode 	<ul style="list-style-type: none"> • Analog Out Mode
<ul style="list-style-type: none"> • Comm Sec NC Fault 	N/A
<ul style="list-style-type: none"> • Sensing Sec NC Fault 	<ul style="list-style-type: none"> • Temp cal Correct • DP Zero Correct and/or • DP Span Correct and/or • Meter Body Input
<ul style="list-style-type: none"> • Sensor Over Temperature 	<ul style="list-style-type: none"> • Temp Module Temp and/or • Meter Body Temp
<ul style="list-style-type: none"> • PV Out Of Range 	<ul style="list-style-type: none"> • PV Out Of Range
<ul style="list-style-type: none"> • No Fact Calib 	<ul style="list-style-type: none"> • Pressure Fac Cal and/or • Temp Fac Cal
<ul style="list-style-type: none"> • No DAC Compensation 	<ul style="list-style-type: none"> • DAC Temp Comp
<ul style="list-style-type: none"> • N/A 	<ul style="list-style-type: none"> • Temp Cal Correct
<ul style="list-style-type: none"> • LRV Set Err. Zero Config Button 	N/A
<ul style="list-style-type: none"> • URV Set Err. Span Config Button 	N/A
<ul style="list-style-type: none"> • CJ Out of Limit 	<ul style="list-style-type: none"> • CJ Range
<ul style="list-style-type: none"> • AO Out of Range 	N/A
<ul style="list-style-type: none"> • Sensor Input Open 	<ul style="list-style-type: none"> • Temp Input and/or • Temp Input TB6
<ul style="list-style-type: none"> • Loop Current Noise 	N/A
<ul style="list-style-type: none"> • Sensor Unreliable Comm 	<ul style="list-style-type: none"> • Meter Body Comm and/or • Temp Comm
<ul style="list-style-type: none"> • Tamper Alarm 	N/A
<ul style="list-style-type: none"> • No DAC Calibration 	N/A
<ul style="list-style-type: none"> • Low Supply Voltage 	<ul style="list-style-type: none"> • Supply Voltage
<ul style="list-style-type: none"> • Flow Calculation Details 	<ul style="list-style-type: none"> • Flow Divide by 0 and/or • Flow Sqrt of Neg and/or • Flow Direction and/or • Flow SP/PT Comp
<ul style="list-style-type: none"> • DP/SP/PT/FLOW Simulation Mode 	<ul style="list-style-type: none"> • DP Simulation and/or • SP Simulation and/or • PT Simulation and/or • Flow Simulation
<ul style="list-style-type: none"> • Sensor health Warning 	N/A
<ul style="list-style-type: none"> • Sensor In Low Power Mode 	N/A

Other Certification Options

Materials

- NACE MRO175, MRO103, ISO15156

Temperature Sensor Wiring Diagram

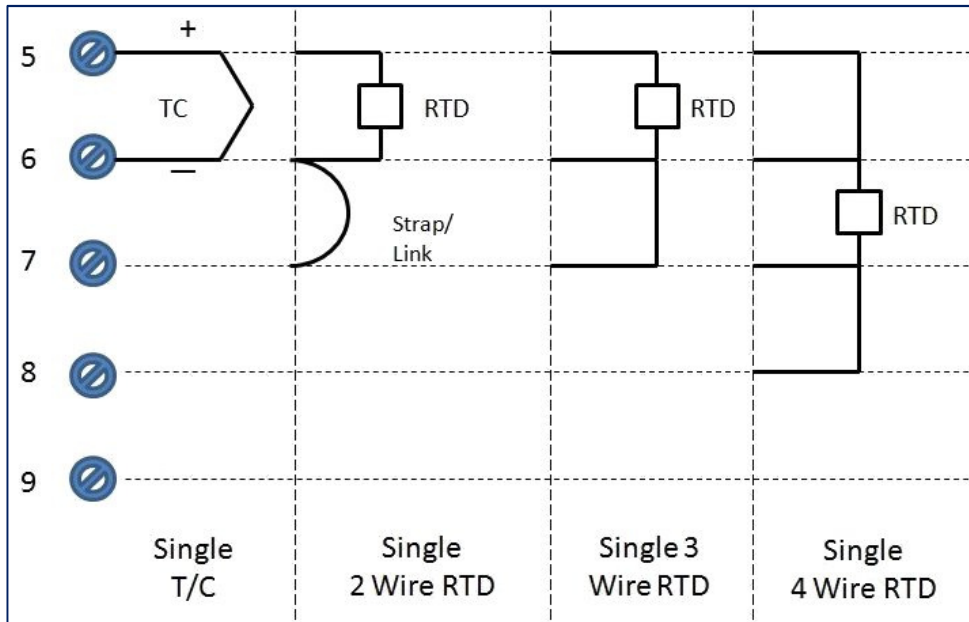

Figure 3 – Temperature sensor Wiring Diagram

Approval Certifications:

MSG CODE	AGENCY	TYPE OF PROTECTION	COMM. OPTION	FIELD PARAMETERS	AMBIENT TEMP (Ta)
A	FM Approvals™	Explosionproof: Class I, Division 1, Groups A, B, C, D; Dust Ignition Proof: Class II, III, Division 1, Groups E, F, G; T4 Class I, Zone 1/2, AEx d IIC T4 Class II, Zone 21, AEx tb IIIC T 85°C IP 66	All	Note 1	-50 °C to 85°C
		Intrinsically Safe: Class I, II, III, Division 1, Groups A, B, C, D, E, F, G; T4 Class 1, Zone 0, AEx ia IIC T4	4-20 mA/ DE/ HART	Note 2	-50 °C to 70°C
		Nonincendive: Class I, Division 2, Groups A, B, C, D locations, Class 1, Zone 2, AEx nA IIC T4	4-20 mA/ DE/ HART	Note 1	-50 °C to 85°C
		Enclosure: Type 4X/ IP66/ IP67	All	All	-
B	Canadian Standards Association (CSA)	Explosion Proof: Certificate: 70007689 Class I, Division 1, Groups A, B, C, D; Dust Ignition Proof: Class II, III, Division 1, Groups E, F, G; T4 Ex d IIC T4 Ex tD A21 T 95°C IP 66	All	Note 1	-50 °C to 85°C
		Intrinsically Safe: Certificate: 70007689 Class I, II, III, Division 1, Groups A, B, C, D, E, F, G; T4 Ex nA IIC T4	4-20 mA/ DE/ HART	Note 2	-50 °C to 70°C
		Nonincendive: Certificate: 70007689 Class I, Division 2, Groups A, B, C, D; T4 Ex nA IIC T4	4-20 mA/ DE/ HART	Note 1	-50 °C to 85°C
		Enclosure: Type 4X/ IP66/ IP67	All	All	-
		Canadian Registration Number (CRN):	All models except and have been registered in all provinces and territories in Canada and are marked CRN: 0F8914.5C.		

Approval Certifications: (Continued)

MSG CODE	AGENCY	TYPE OF PROTECTION	COMM. OPTION	FIELD PARAMETERS	AMBIENT TEMP (Ta)
C	ATEX	Flameproof: Certificate : SIRA 15ATEX2039X II 1/2 G Ex d IIC T4 II 2 D Ex tb IIIC T 85°C IP 66	All	Note 1	-50 °C to 85°C
		Intrinsically Safe: Certificate : SIRA 15ATEX2039X II 1 G Ex ia IIC T4	4-20 mA/ DE/ HART	Note 2	-50 °C to 70°C
		Nonincendive: Certificate : SIRA 15ATEX4040X II 3 G Ex nA IIC T4	4-20 mA/ DE/ HART	Note 1	-50 °C to 85°C
		Enclosure: IP66/ IP67	All	All	All
D	IECEx (World)	Flameproof : Certificate : SIR 15.0022X Ga/Gb Ex d IIC T4 Ex tb IIIC T 85°C IP 66	All	Note 1	-50 °C to 85°C
		Intrinsically Safe: Certificate : SIR 15.0022X Ex ia IIC T4	4-20 mA/ DE/ HART	Note 2	-50 °C to 70°C
		Nonincendive: Certificate : SIR 15.0022X Ex nA IIC T4	4-20 mA/ DE/ HART	Note 1	-50 °C to 85°C
		Enclosure: IP66/ IP67	All	All	All

Notes:

1. Operating Parameters:

Voltage= 11 to 42 V DC Current= 4-20 mA Normal (3.8 – 23 mA Faults)

2. Intrinsically Safe Entity Parameters

Analog/ DE/ HART Entity Values:

Vmax= Ui = 30V I_{max}= I_i= 225 mA Ci = 4.2nF Li = 0uH Pi =0.9W

Mounting & Dimensional Drawings

Reference Dimensions: $\frac{\text{millimeters}}{\text{inches}}$

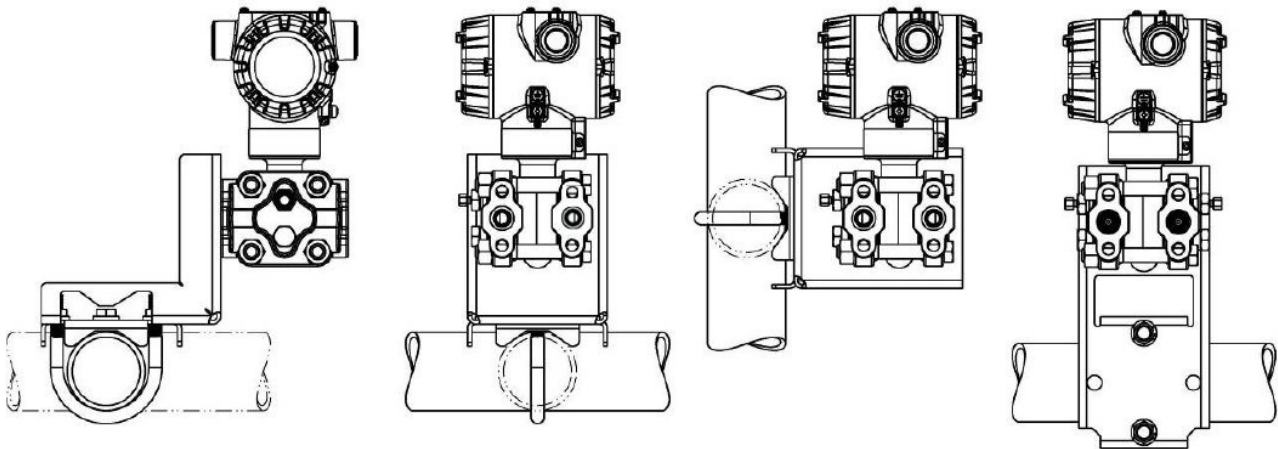

Figure 4 – Mounting Configurations

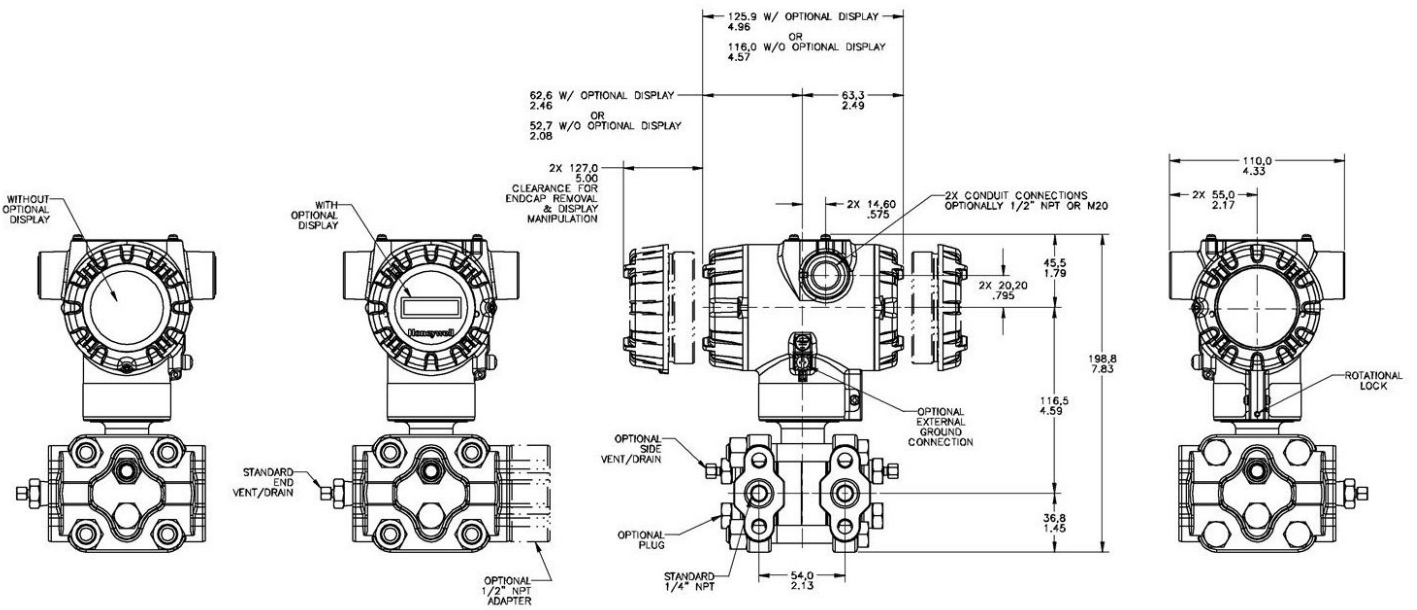
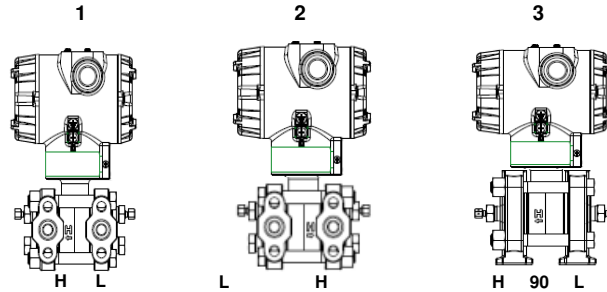

Figure 5 – Typical mounting dimensions for reference

Model Selection Guide



SMG870
 SMA845
 SMA810

1	*	*	*
2	*	*	*
3	h	h	h

TABLE IV		Meter Body & Connection Orientation	
Head/Connect Orientation	Standard	High Side Left, Low Side Right ² / Std Head Orientation	
	Reversed	Low Side Left, High Side Right ² / Std Head Orientation	
	90/Standard	High Side Left, Low Side Right ² / 90° Head Rotation	

TABLE V		Agency Approvals (see data sheet for Approval Code Details)	
Approvals	No Approvals Required		
	FM Explosion proof, Intrinsically Safe, Non-incendive, & Dustproof		
	CSA Explosion proof, Intrinsically Safe, Non-incendive, & Dustproof		
	ATEX Explosion proof, Intrinsically Safe & Non-incendive		
	IECEx Explosion proof, Intrinsically Safe & Non-incendive		

0	*	*	*
A	*	*	*
B	*	*	*
C	*	*	*
D	*	*	*

TABLE VI				TRANSMITTER ELECTRONICS SELECTIONS			
a. Electronic Housing Material & Connection Type	Material		Connection		Lightning Protection		
	Polyester Powder Coated Aluminum		1/2 NPT		None		
			M20		None		
	316 Stainless Steel (Grade CF8M)		1/2 NPT		Yes		
			M20		Yes		
			1/2 NPT		None		
M20			None				
1/2 NPT		Yes					
M20		Yes					
b. Output/ Protocol	Analog Output		Digital Protocol				
	4-20mA dc		HART Protocol				
4-20mA dc		DE Protocol					
c. Customer Interface Selections	Indicator		Ext Zero, Span & Config Buttons		Languages		
	None		None		None		
	None		Yes (Zero/Span Only)		None		
	Advanced		None		EN,DE,FR,IT,ES,RU,TU		
	Advanced		Yes		EN,DE,FR,IT,ES,RU,TU		
	Advanced		None		EN, CH, JP		
Advanced		Yes		EN, CH, JP			

A __	*	*	*
B __	*	*	*
C __	*	*	*
D __	*	*	*
E __	*	*	*
F __	*	*	*
G __	*	*	*
H __	*	*	*

_ H _	*	*	*
_ D _	u	u	u

_ _ 0	*	*	*
_ _ A	*	*	*
_ _ D	*	*	*
_ _ E	*	*	*
_ _ H	*	*	*
_ _ J	*	*	*

TABLE VII				CONFIGURATION SELECTIONS			
a. Application Software	Diagnostics						
	Standard Diagnostics						
b. Output Limit, Failsafe & Write Protect Settings	Write Protect	Fail Mode	High & Low Output Limits ³				
	Disabled	High > 21.0mAdc	Honeywell Std (3.8 - 20.8 mAdc)				
	Disabled	Low < 3.6mAdc	Honeywell Std (3.8 - 20.8 mAdc)				
	Enabled	High > 21.0mAdc	Honeywell Std (3.8 - 20.8 mAdc)				
	Enabled	Low < 3.6mAdc	Honeywell Std (3.8 - 20.8 mAdc)				
c. General Configuration	Factory Standard						
Custom Configuration (Unit Data Required from customer)							

1 _ _	*	*	*
-------	---	---	---

_ 1 _	*	*	*
_ 2 _	*	*	*
_ 3 _	*	*	*
_ 4 _	*	*	*
_ _ S	*	*	*
_ _ C	*	*	*

² Left side/Right side as viewed from the customer connection perspective

³ NAMUR Output Limits 3.8 - 20.5mAdc can be configured by the customer or select custom configuration Table Vc

Model Selection Guide

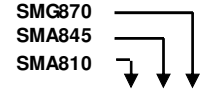

TABLE VIII PV1,PV2 & PV3 CALIBRATION & ACCURACY SELECTIONS			
	Accuracy	Calibrated Range	# of Calibrations
a. Accuracy and Calibration	Standard	PV1,PV2&PV3 Factory Std	PV1,PV2&PV3 Single Calibration
		PV1,PV2&PV3 Custom (Unit Data Required)	PV1,PV2&PV3 Single Calibration
		PV1,PV2&PV3 Custom (Unit Data Required)	PV1&PV2 Dual Calibration
		PV1,PV2&PV3 Custom (Unit Data Required)	PV1&PV2 Triple Calibration

A	*	*	*
B	*	*	*
C	*	*	*
D	*	*	*

TABLE IX ACCESSORY SELECTIONS		
	Bracket Type	Material
a. Mounting Bracket	None	None
	Angle Bracket	Carbon Steel
	Angle Bracket	304 SS
	Angle Bracket	316 SS
	Flat Bracket	Carbon Steel
	Flat Bracket	304 SS
	Flat Bracket	316 SS
b. Customer Tag	Customer Tag Type	
	No customer tag	
	One Wired Stainless Steel Tag (Up to 4 lines 26 char/line) Two Wired Stainless Steel Tag (Up to 4 lines 26 char/line)	
c. Unassembled Conduit Plugs & Adapters	Unassembled Conduit Plugs & Adapters	
	No Conduit Plugs or Adapters Required	
	1/2 NPT Male to 3/4 NPT Female 316 SS Certified Conduit Adapter	
	1/2 NPT 316 SS Certified Conduit Plug	
	M20 316 SS Certified Conduit Plug	
	Minifast® 4 pin (1/2 NPT) (not suitable for X-Proof applications) Minifast® 4 pin (M20) (not suitable for X-Proof applications)	

0	---	*	*	*
1	---	*	*	*
2	---	*	*	*
3	---	*	*	*
5	---	*	*	*
6	---	*	*	*
7	---	*	*	*

_0	_	*	*	*
_1	_	*	*	*
_2	_	*	*	*

_A0	*	*	*
_A2	n	n	n
_A6	n	n	n
_A7	m	m	m
_A8	n	n	n
_A9	m	m	m

TABLE X OTHER Certifications & Options: (String in sequence comma delimited (XX, XX, XX,...))	
Certifications & Warranty	None - No additional options
	NACE MR0175; MR0103; ISO15156 (FC33338) Process wetted parts only
	NACE MR0175; MR0103; ISO15156 (FC33339) Process wetted and non-wetted parts
	EN10204 Type 3.1 Material Traceability (FC33341)
	Certificate of Conformance (F3391)
	Calibration Test Report & Certificate of Conformance (F3399)
	Certificate of Origin (F0195)
	Over-Pressure Leak Test Certificate (1.5X MAWP) (F3392)
	Cert Clean for O ₂ or CL ₂ service per ASTM G93
	Extended Warranty Additional 1 year
	Extended Warranty Additional 2 years
	Extended Warranty Additional 3 years
	Extended Warranty Additional 4 years
	Extended Warranty Additional 15 years

00	*	*	*
FG	*	*	*
F7	c	c	c
FX	*	*	*
F3	*	*	*
F1	*	*	*
F5	*	*	*
TP	*	*	*
OX	e	e	e
01	*	*	*
02	*	*	*
03	*	*	*
04	*	*	*
15	*	*	*

TABLE XI Manufacturing Specials	
Factory	Factory Identification

0000	*	*	*
------	---	---	---

MODEL RESTRICTIONS

Restriction Letter	Available Only with		Not Available with	
	Table	Selection(s)	Table	Selection(s)
a			X	F7, FG
c	IIId	___ N,K,D,B ___	IIIa	C,D,3,G,H,6,K,L,8
e	IIIb	_ 2 _		
h			IIIe	4, 5, 6
			IXa	1,2,3,5,6,7
m	Via	B, D, F, H __		
n	Vla	A, C, E, G __		
p			V	B- No CRN number available
t			IIIa	J, K, 7, L, 8
u			VIIIa	C,D
b	Select only one option from this group			

Model Selection Guide

FIELD INSTALLABLE/ACCESSORY PARTS

Description	Kit Number
Integrally Mounted Advanced Indicator Kit (EN,DE,FR,ES,IT,RU,TU - compatible with all Electronic Modules)	50049846-506
Integrally Mounted Advanced Indicator Kit (EN, CH, JP - compatible with all Electronic Modules)	50087087-503
Terminal Strip w/o Lightening Protection for HART or DE Modules	50086421-501
Terminal Strip w/Lightning Protection Kit for HART or DE Modules	50086421-503
Terminal Strip w/o Lightening Protection FFB/ <i>Profibus</i> Module	50086421-507
Terminal Strip w/Lightning Protection Kit for FFB/ <i>Profibus</i> Module	50086421-509
HART Electronics Module	50098718-501
HART Electronics Module w/connection for external configuration buttons	50098718-502
DE Electronics Module	50098718-503
DE Electronics Module w/connection for external configuration buttons	50098718-504

PAPER MANUALS

Description	Part Number
Paper Manual SMV 800 Smart Transmitter User Manual - English	34-SM-25-03
Paper Manual SMV 800 Smart Transmitter HART/DE Communications Manual - English	34-SM-25-06

Sales and Service

For application assistance, current specifications, pricing, or name of the nearest Authorized Distributor, contact one of the offices below.

ASIA PACIFIC

Honeywell Process Solutions,
(TAC) hfs-tac-support@honeywell.com

Australia

Honeywell Limited
Phone: +(61) 7-3846 1255
FAX: +(61) 7-3840 6481
Toll Free 1300-36-39-36
Toll Free Fax:
1300-36-04-70

China – PRC - Shanghai

Honeywell China Inc.
Phone: (86-21) 5257-4568
Fax: (86-21) 6237-2826

Singapore

Honeywell Pte Ltd.
Phone: +(65) 6580 3278
Fax: +(65) 6445-3033

South Korea

Honeywell Korea Co Ltd
Phone: +(822) 799 6114
Fax: +(822) 792 9015

EMEA

Honeywell Process Solutions,
Phone: + 80012026455 or
+44 (0)1344 656000

Email: (Sales)

FP-Sales-Apps@Honeywell.com

or

(TAC)

hfs-tac-support@honeywell.com

AMERICA'S

Honeywell Process Solutions,
Phone: (TAC) 1-800-423-9883 or
215/641-3610
(Sales) 1-800-343-0228

Email: (Sales)

FP-Sales-Apps@Honeywell.com

or

(TAC)

hfs-tac-support@honeywell.com

Specifications are subject to change without notice.

For more information

To learn more about SmartLine Transmitters,
visit www.honeywellprocess.com
Or contact your Honeywell Account Manager

Process Solutions

Honeywell
1250 W Sam Houston Pkwy S
Houston, TX 77042

Honeywell Control Systems Ltd
Honeywell House, Skimped Hill Lane
Bracknell, England, RG12 1EB

Shanghai City Centre, 100 Jungi Road
Shanghai, China 20061

www.honeywellprocess.com

Honeywell

34-SM-03-92

October 2015

©2015 Honeywell International Inc.