

M-AUDIO

Oxygen Series

User Guide

1 Introduction

Congratulations on purchasing an M-Audio Oxygen Series keyboard. Oxygen keyboards now offer DirectLink, which provides support for Digital Audio Workstations (DAW)¹ such as Pro Tools 8 by automatically mapping the track and master volume sliders, slider buttons, pan knobs and transport controls to their corresponding functions in the program.

A single USB connection not only sends MIDI data to the computer, but also provides power to the keyboard. All Oxygen Series keyboards function as class-compliant devices and will be recognized by your computer without the need to install additional drivers. Simply use the included USB cable to connect the keyboard to an available USB port on your computer and set the power switch to the On position.

Please refer to Section 5 of this Guide for more information on keyboard setup (including optional driver installation), and configuration of your recording application.

2 What's in the Box

The Oxygen Series keyboard packaging includes the following:

- ▶ Oxygen Series keyboard
- ▶ USB Cable
- ▶ Printed Quick Start Guide
- ▶ Oxygen Series disk

¹ Please check www.m-audio.com for a current list of supported recording applications, the most recent DirectLink installers, and configuration instructions. Applications not directly supported via DirectLink can be controlled by using your recording application's "MIDI learn" feature or by mapping the Oxygen controls manually. See sections 8 and 9 of this guide for more information.

3 Oxygen Series Features

- ▶ 25, 49 or 61 velocity sensitive full-size keys
- ▶ Automatic mapping of top panel controls to supported DAWs
- ▶ Advanced programming functions via the keyboard
- ▶ Octave/Transpose buttons
- ▶ 2 Track Select buttons
- ▶ 9 sliders (1 on Oxygen 25); MIDI re-assignable
- ▶ 9 buttons (Oxygen 49/61 only); MIDI re-assignable
- ▶ 8 knobs; MIDI re-assignable
- ▶ Pitch Bend and Modulation wheels; MIDI re-assignable
- ▶ 6 Transport Buttons; MIDI re-assignable
- ▶ Sustain pedal input; MIDI re-assignable
- ▶ 10 user editable memory locations
- ▶ 3 digit LED screen
- ▶ USB 2.0 port (backward compatible with USB 1.1)

4 Minimum System Requirements

Minimum system requirements can be found on the Oxygen Series product packaging as well as the M-Audio website at www.m-audio.com.

5 Setup

Oxygen Series keyboards function as class-compliant devices and will be recognized by your computer without the need to install additional drivers. Simply use the included USB cable to connect the keyboard to an available USB port on your computer and set the power switch to the On position.

Windows users, who are planning to:

- *use the keyboard with more than one application at the same time*

or

- *simultaneously use other class-compliant USB devices with audio capabilities*

...must install the latest Oxygen Series drivers found at the M-Audio website www.m-audio.com.

Windows XP and Windows Vista Installation Instructions

NOTE: Make sure your Oxygen keyboard is not connected to the computer when beginning the installation. The following instructions will indicate when you should connect it to your computer.

1. Install the Oxygen Series drivers by doing one of the following:
 - ▶ Download the latest Oxygen Series drivers from the Support > Drivers page at www.m-audio.com. Once you have saved the installer to your computer, double-click the file to start the installation process.
 - ▶ Select Oxygen Series from the menu and click "Install." ❶

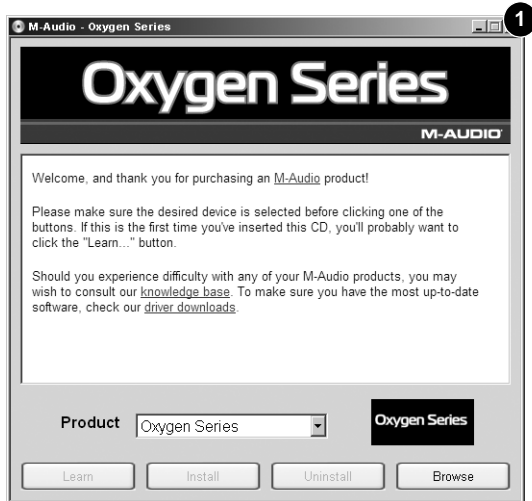

2. Follow the driver installer's on-screen instructions. At various points in this installation process, you may be notified that the driver being installed has not passed Windows Logo Testing, or asked whether the program you wish to run is a trusted application. Click "Continue Anyway" ❷ (Windows XP) or "Install" ❸ (Windows Vista) to proceed with the installation.

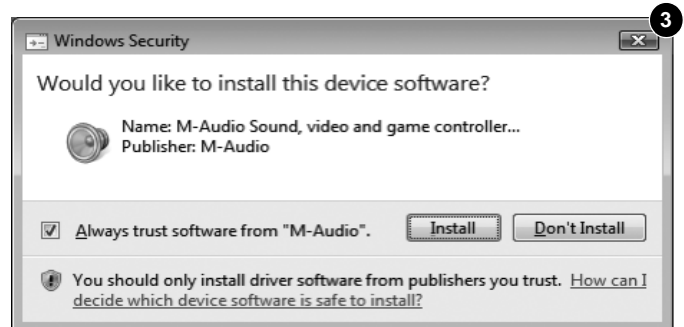
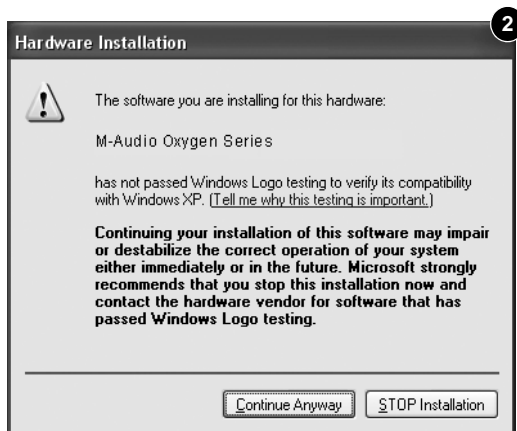

3. Once the installer has completed, click "Finish."
4. Connect your Oxygen Keyboard to an available USB port on your computer. If you are using Windows Vista, your Oxygen keyboard is now ready to use. If you are using Windows XP, proceed with steps 5-8.

5. Windows XP will identify the keyboard and ask if you want to search the Internet for a driver. Select "No, not this time" and press "Next." **4**
6. Windows XP will display a Found New Hardware Wizard dialog. Choose "Install the software automatically" and click "Next." **5**

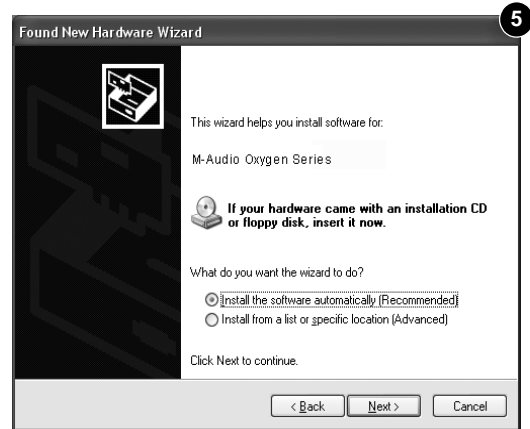

7. Once the Wizard has completed, click "Finish." If you are presented with another Found New Hardware Wizard dialog, repeat steps 5-7.
8. When the installation is complete, you will see a message stating "Your new hardware is installed and ready to use."

Mac OS X Installation Instructions

The class-compliant drivers built into Mac OS X provide full support for all features of Oxygen series keyboards. This means that no additional M-Audio drivers are necessary (or available) when using your Oxygen keyboard on Mac OS X - simply connect the controller keyboard to the computer using the supplied USB cable, configure your recording software and start making music.

Host Software Configuration

When using an Oxygen series keyboard², you may need to configure your music software to receive MIDI data. This process varies from one application to another, but is usually done through a "Preferences," "Setup," or "Options" menu. Please refer to the documentation for your DAW software to learn how to do this.

Because Oxygen Series keyboards do not contain built-in sounds, pressing a key will only send MIDI data to the computer, giving instructions on when and how a note should play. A virtual instrument loaded onto a track of your DAW software then creates the sound, based on the instructions received from your Oxygen keyboard. Please refer to the documentation for your DAW software for more details on using virtual instruments.

² In Windows XP, the Oxygen MIDI ports will appear as "USB Audio Device" for all models. Install the M-Audio Oxygen drivers as described earlier (available from www.m-audio.com) for the ports to appear as described above.

6 DirectLink / DAW Support

DirectLink automatically maps the track volume and master sliders, slider buttons (mute/solo), pan knobs and transport controls to their corresponding functions in supported recording applications³ such as Pro Tools 8.

Installation

In order to use DirectLink, you must first install the DirectLink support files for your DAW software. Check www.m-audio.com for a current list of supported recording applications, then download and save the DirectLink installer for the DAW software you use. Once the download has finished, close your DAW software (if it is running), then double-click the downloaded file and follow the onscreen instructions.

1. Close the DAW application if it is currently running
2. Download and save the DirectLink installation program for your DAW
3. Locate the downloaded file, and double-click on its icon to launch the installer
4. Save or print the configuration instructions contained in the installation program
5. Follow all on-screen instructions and prompts

DAW Configuration

Once the DirectLink files have been installed, you must configure your DAW software for use with DirectLink. The configuration procedure varies between different applications. Please print and follow the configuration steps contained within the DirectLink installer. Pro Tools 8 users can use the configuration instructions listed below.

DirectLink Configuration for Pro Tools 8:

(For DAW applications other than Pro Tools, please check the configuration instructions contained in the DirectLink installer, available for download from www.m-audio.com).

1. Launch Pro Tools
2. Select "Peripherals" from the Setup menu
3. Select the "MIDI Controllers" tab from the window that appears
4. Click the first "Type" drop-down menu and select "M-Audio Keyboard"
5. Click the first "Receive From" drop-down menu and select the "Oxygen 49 In" port³
6. Click the first "Send To" drop-down menu and select the "Oxygen 49 Out" port³
7. Make sure that "8" is selected in the "# Ch's" drop-down menu and click "OK" to close the window

Load Preset 10 (DirectLink Preset) on your Oxygen keyboard:

1. Press the Select button until the lower edge of the LED display shows a red dot above "PRESETS"
2. Scroll through the Preset numbers using the "-" or "+" buttons until the LED display shows "P10."

Applications not currently supported by DirectLink:

Most DAW applications that are not directly supported by DirectLink allow mapping of the Oxygen top panel controls by using the software's MIDI Learn function. Refer to the documentation provided with the DAW software for more information about its MIDI learn capabilities.

If your software does not support DirectLink or MIDI learn, it may be possible to control it manually by assigning the buttons, knobs and sliders of your Oxygen keyboard to the MIDI CC numbers for various software parameters.

For further information, please refer to *Section 8 - Advanced Keyboard Functions*, and *Section 9 - Advanced Programming Functions*.

³ These MIDI port names will display the number of keys, based on the Oxygen Series model you use: 25, 49 or 61. In Windows XP, the Oxygen MIDI ports will appear as "USB Audio Device" for all models. Install the M-Audio Oxygen drivers (available from www.m-audio.com) in Windows XP for the ports to appear as described above.

7 Controls and Connectors

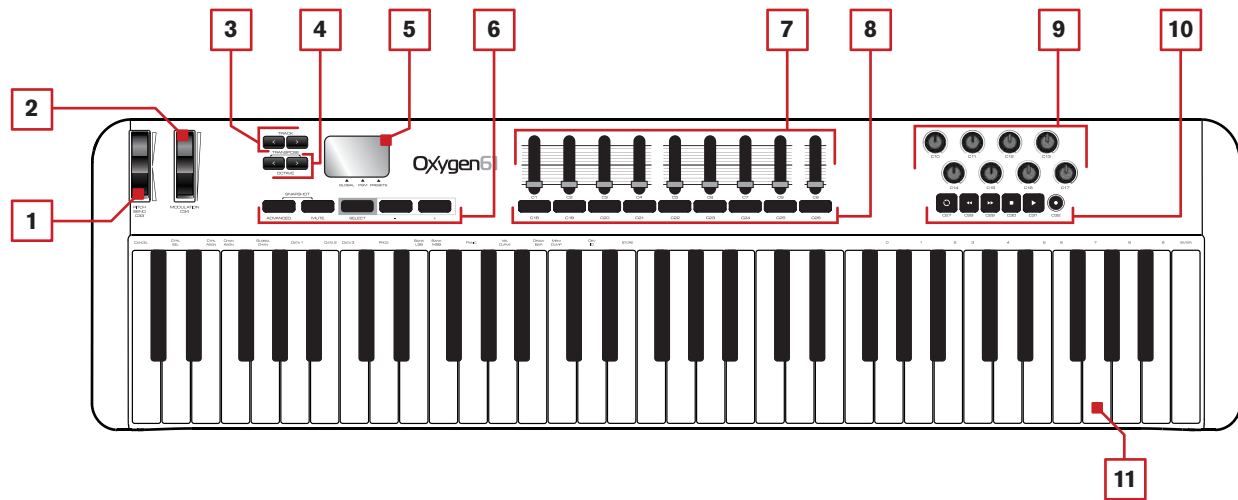

About DirectLink:

Once installed and configured, DirectLink automatically maps many of the top panel controls of Oxygen Series keyboards to their corresponding functions in supported recording applications.

Where applicable, the following section will explain both, the operation of these controls when using DirectLink, as well as their default MIDI assignments.

Top Panel

1. Pitch Bend Wheel:

This wheel creates expressive changes in performances by raising and lowering pitch. Rolling the Pitch Bend wheel upward will raise an instrument's pitch whereas rolling it downward will lower the pitch. The upper and lower pitch bend limit is determined by settings on your hardware or software synthesizer, not by the Pitch Bend wheel on the Oxygen Series keyboard itself. Typically, this can be either a half note or an octave up/down. This wheel is spring mounted and will return to the center detente position when released.

The Pitch Bend wheel is an assignable controller capable of sending a variety of MIDI messages other than pitch bend data. See Appendix A for a list of parameters the Pitch Bend wheel can be assigned to.

2. Modulation Wheel:

This wheel is used to add expression to performances by changing the intensity of certain effects. By default, most synthesizers assign this wheel to control vibrato (change in intonation) or tremolo (change in volume) although it is usually possible to reassign the function of this wheel through the instrument's control panel.

Rolling the Modulation Wheel upward will increase the modulation effect, while rolling downward will reduce the effect.

The Modulation Wheel is an assignable controller capable of sending a variety of MIDI messages other than Modulation data. See Appendix A for a list of parameters the Modulation wheel can be assigned to.

3. Track Buttons:

DirectLink Operation:

The left Track button (<) selects the previous Track in supported DAW applications. For example if Track 2 is currently selected, pressing this button will select Track 1 in the application.

The right Track button (>) selects the next Track in supported DAW applications. For example if Track 2 is currently selected, pressing this button will select Track 3 in the application.

These buttons also allow the selection of tracks outside the currently active bank of 8 sequencer tracks. For example, if track 8 is currently selected and the > track button is pressed, track 9 will be selected. The track sliders and their corresponding buttons will now control Tracks 9 - 16.

Standard Operation:

The left Track button sends MIDI CC 14, while the right Track button sends MIDI CC 15. These buttons are not re-assignable to other MIDI parameters. Use the recording program's "MIDI Learn" function (if available) to assign these buttons to software functions as desired. Refer to the manual provided with your DAW software for more information about its MIDI Learn capabilities.

4. Octave / Transpose Buttons:

The Octave buttons are used to shift the keyboard up or down in one octave increments, to extend the range of playable notes. The Right button (>) shifts upward (note F3 becomes F4), while the Left button (<) shifts downward (note F3 becomes F2).

Transpose is the secondary function of these two buttons and can be accessed by pressing both buttons simultaneously. In this mode, pressing the Right button shifts the keyboard upward by one half-step (semi tone). As a result, note F3 becomes F#3. Pressing the Left button shifts the keyboard downward by one half-step (F3 becomes E3).

5. LED Screen:

All Oxygen Series keyboards feature a 3 digit LED display providing visual information regarding current operation, programming and controller status.

6. Function Buttons:

All Oxygen Series keyboards feature 5 function buttons for programming, access to settings and advanced features as outlined below.

Advanced

The Advanced button allows access to the extended parameters listed along the top edge of the keyboard. When the Advanced button is pressed, the LED screen shows three dots along the bottom of the display, indicating that the keyboard is in Advanced mode. Please refer to *Section 8 - Advanced Keyboard Functions* and *Section 9 - Advanced Programming Functions* for more information on how this function is used.

Mute

When the Mute button is activated, the Knobs and Sliders will not transmit MIDI data and the LED screen will display "OFF" while adjusting them. This allows changes to Slider and Knob positions without affecting the settings of connected MIDI devices or applications.

As shown in the following example, the Mute function can be used to prevent "jumps" caused by differences between the physical positions of sliders and knobs on an Oxygen keyboard, and the expected values of the corresponding software parameters:

When loading a new sound patch for a virtual instrument in your DAW software, its settings will likely not match the current positions of the knobs on the Oxygen keyboard and will be "out-of-sync" with what the virtual instrument is expecting. In other words, an Oxygen Knob may be set to 64 (center position) while the sound patch expects this value to be at zero (all the way to the left). This may cause this synthesizer setting to jump or "snap" from zero to 64 when the Oxygen Knob is adjusted, which can be a jarring experience if the knob is controlling a parameter like Master Volume or Filter.

These value jumps can be prevented by first pressing the Mute button, and then setting the Knobs and Sliders to their expected positions before using them with a new sound patch. Press the Mute button a second time to exit Mute mode.

***NOTE:** The Mute function does not affect the buttons, keys or the sustain pedal and pressing any of them automatically cancels Mute mode.*

Snapshot (Advanced & Mute)

Pressing the Advanced and Mute buttons at the same time activates the Snapshot function. The LED screen momentarily shows "S-S" and the Oxygen keyboard immediately sends the current values of all knobs and sliders. This feature can be used to simultaneously change multiple parameters within the software you are controlling to match the settings on your Oxygen keyboard.

Select

The Select button assigns the "-" and "+" buttons to one of three parameters as indicated by a dot along the lower edge of the LED display:

- ▶ GLOBAL; The - / + buttons set the global MIDI channel.
- ▶ PGM (program); The - / + buttons transmit program change messages.
- ▶ PRESETS; The - / + buttons step through and load Oxygen presets from its 10 memory locations.

"-" and "+" Buttons

These buttons are used in combination with the Select button, to decrease (–) or increase (+) the value of the currently active function or parameter (Global MIDI channel, Program Change, Preset Number).

7. Sliders:

Oxygen 49 and 61 feature nine Sliders. Oxygen 25 features one Slider.

DirectLink Operation:

Oxygen 49 and 61: The first eight sliders automatically map to control the track volume for the currently selected bank of eight tracks in a supported DAW application. The right-most Slider (C9) maps to the master volume fader of a supported DAW application.

Oxygen 25: The single slider will map to the master volume fader of a supported DAW.

Standard Operation:

These sliders send different types of standard MIDI CC messages or advanced MIDI messages (see Appendix B), based on the parameter they are assigned to, or the active preset. Each slider can be mapped to control various parameters in your DAW by using your recording application's MIDI Learn function (if available – check the user documentation for your DAW), or assigning the slider manually as described in *Section 9 - Advanced Programming Functions*.

8. Slider Buttons:

Oxygen 49 and 61 feature nine Slider Buttons.⁴

DirectLink Operation:

The first eight buttons map to the currently active bank of eight tracks within supported DAW applications. By default, pressing a Slider button will mute the corresponding DAW track. Pressing and holding the right-most Button (C26) places all other Slider buttons in Solo mode. While the right-most button is held down, pressing another Slider button will solo the corresponding DAW track.

When using Pro Tools 8, the right-most Slider button (C26) also allows using the eight Oxygen control knobs to adjust either the left, or the right pan knobs of Pro Tools stereo tracks (only available on Oxygen 49 and 61). By default, the Oxygen knobs control the left pan knobs of stereo tracks. While the right-most button is held down, the Oxygen knobs control the right pan knobs of Pro Tools stereo tracks.

Standard Operation:

These buttons send different types of standard MIDI CC, MIDI note or other advanced MIDI messages (see Appendix B), based on the parameter they are assigned to, or the active preset. Each button can be mapped to control various parameters in your DAW by using your recording software's MIDI Learn function (if available – check the user documentation for your DAW), or assigning the Oxygen controls manually as described in *Section 9 - Advanced Programming Functions*.

⁴Not available on Oxygen 25

9. Knobs:

All Oxygen Series keyboards feature 8 MIDI Control Knobs.

DirectLink Operation:

Oxygen 49 and 61: These knobs map to control the panorama or balance setting for the currently active bank of eight tracks in a supported DAW application. When working with stereo tracks in Pro Tools 8, pressing the right-most Slider button (C26) will select either the left or right pan control.

Oxygen 25: These knobs map to control the track volume for the currently active bank of eight tracks in a supported DAW application.

Pro Tools 8 users can place the 8 control knobs into Instrument mode by quickly pressing the Loop button. In this mode, the 8 control knobs automatically map to 8 parameters on the active Instrument or Effect Plug-In. The Instrument mode parameter mapping can be customized by clicking the "learn" button in the upper right corner of the Plug-In. Please check the Pro Tools 8 documentation for more details.

Standard Operation:

These knobs send different types of standard MIDI CC messages or advanced MIDI messages (see Appendix B), based on the parameter they are assigned to, or the active preset. Each knob can be mapped to control various parameters in your DAW by using your recording application's MIDI Learn function (if available – check the user documentation for your DAW), or assigning the Oxygen knobs manually as described in *Section 9 - Advanced Programming Functions*.

10. Transport Buttons:

All Oxygen Series keyboards feature 6 Transport Buttons.

DirectLink Operation:

These buttons map to the Transport Buttons in supported DAW applications to control playback, record, start/stop, fast forward and rewind, as well as enabling (or disabling) of the loop function.

Pro Tools 8 users can access additional functions via the Loop button:

- a. Holding the Loop button while pressing one of the other Transport Control buttons gives access to additional Pro Tools transport functions. See Appendix D for more details.
- b. Quickly pressing the Loop button toggles the control knobs on your Oxygen keyboard between Instrument Mode and Mixer mode.
 - Mixer mode (default):, The 8 knobs control their corresponding tracks' pan or balance settings.
 - Instrument Mode: The control knobs automatically map to 8 parameters on the active Instrument or Effect Plug-In. The Instrument mode parameter mapping can be customized by clicking the "learn" button in the upper right corner of the Plug-In. Please check the Pro Tools 8 documentation for more details.

Standard Operation:

These buttons send standard MIDI CC, MIDI note, MMC (MIDI Machine Control) or other advanced MIDI messages (see Appendix B), based on the parameter they are assigned to, or the active preset. Each button can be reassigned to control various parameters in your DAW, including the transport controls, by using your recording application's MIDI Learn function (if available – check the user documentation for your DAW), or assigning the Oxygen controls manually as described in *Section 9 - Advanced Programming Functions*.

11. Velocity-sensitive Keyboard:

The velocity sensitive keyboard is not only the primary method of sending Note On/ Off and Velocity data when performing, it is also used to access extended programming functions listed along its upper edge.

Please refer to *Section 8 - Advanced Keyboard Functions* and *Section 9 - Advanced Programming Functions* for more information on the extended keyboard functions and how to use them for programming.

Back Panel

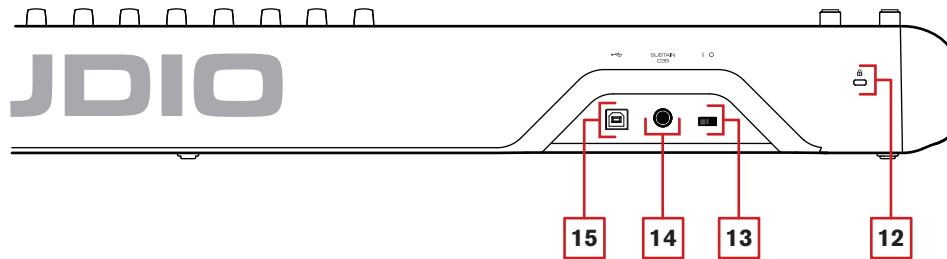

12. Kensington® Lock Connector:

This connector is compatible with standard laptop-style Kensington® security cables for theft protection.

13. On/Off Switch:

Use this switch to power the device on or off. When this switch is set to the on position, Oxygen is powered through the USB connection to your computer.

14. Sustain Pedal Input:

This socket accepts a momentary-contact foot pedal (not included). When pressed, this pedal will sustain the sound you are playing without having to keep your fingers pressing down the keys.

NOTE: The polarity of the sustain pedal is determined by the keyboard upon startup. When an Oxygen keyboard is powering up, the sustain pedal is assumed to be in the "up" (Off) position. It is important that the sustain pedal is not pressed during startup, otherwise the pedal will reverse its operation, and notes will sustain when the pedal is not pressed.

15. USB Port:

The USB 2.0 port (backward compatible with USB 1.1) delivers power to the keyboard and transmits MIDI data when connected to a computer.

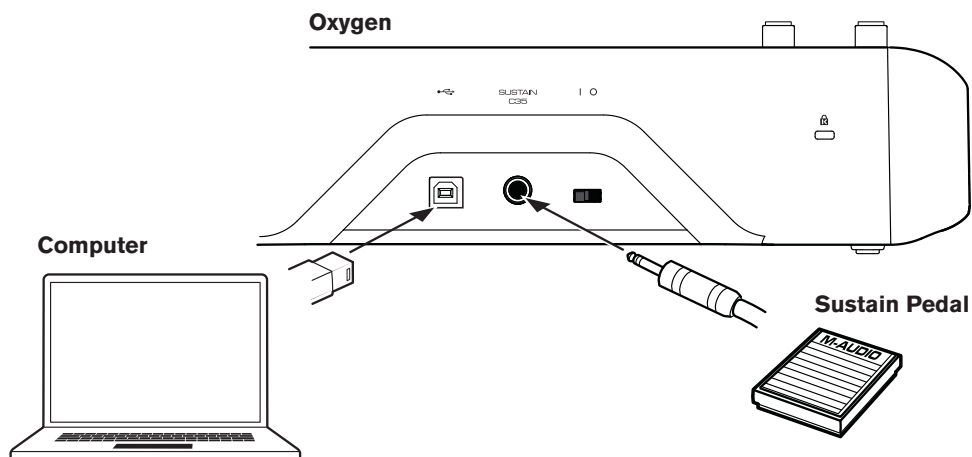

8 Advanced Keyboard Functions

Oxygen Series keyboards include extended programming capabilities through secondary functions of the keys. The available parameters are listed along the top edge of the keyboard, and accessed by pressing the Advanced button. The LED screen shows the numerical value of the parameter being edited.

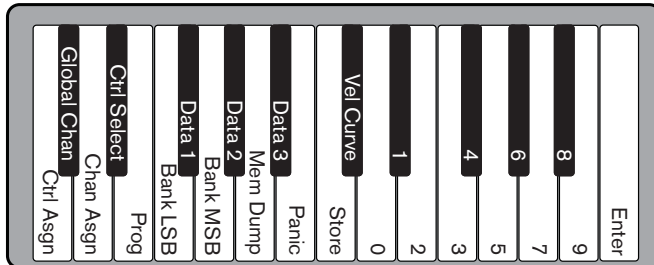

Oxygen 25

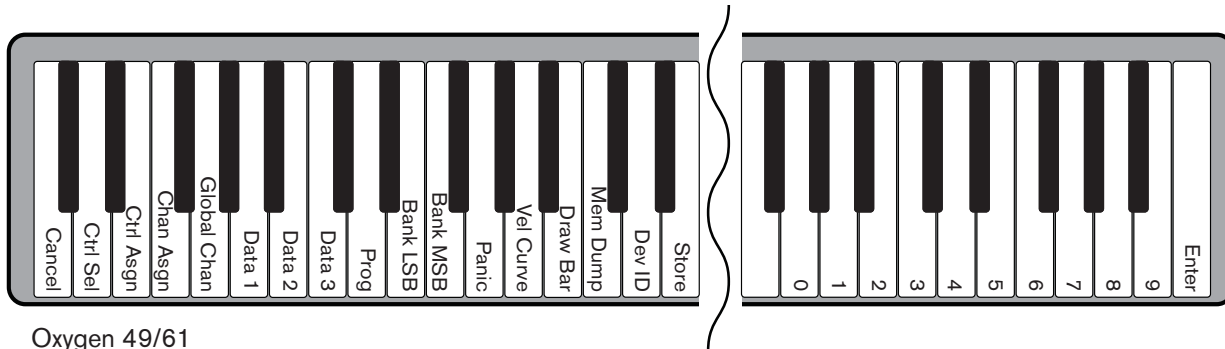

Oxygen 49/61

Cancel (Oxygen 49 and 61 only)

Pressing the Cancel key will exit advanced mode, discarding all changes. Alternatively, pressing the Advanced button a second time will yield the same result.

Oxygen 25 does not feature a dedicated Cancel key. Press the Advanced button a second time to cancel all changes and exit Advanced mode.

NOTE: The Panic, Drawbar and Memory Dump functions take immediate effect and cannot be cancelled once the corresponding key has been pressed.

Control Select

The Control Select function (CTRL SEL) is used to select a MIDI control (a Knob, Button, Slider or the Sustain Pedal jack) for editing.

NOTE: Every control is labeled with a unique number, such as C1, C2, etc. It is not necessary (or possible) to enter the letter C when following the editing examples below.

1. Press the Advanced button
2. Press the Control Select key
3. Enter the control's ID number using the number keys
4. Press the Enter key to confirm

- or -

Move or press the control to be programmed, before or after pressing the Advanced button.

Control Assign, Data 1, Data 2, Data 3

The Control Assign function (CTRL ASGN) assigns a MIDI continuous control number (MIDI CC), or other MIDI parameter from the table in Appendix B to the selected Knob, Button, Slider, or to the Sustain Pedal jack. The Data 1, Data 2, and Data 3 keys define various related aspects of the parameter or function assigned to a control.

For example, it is possible to configure a Button to send MIDI note On/Off Data by assigning it to controller number 147. The Data 1 key is used to specify the pitch (or note number) of the MIDI note for the button (see Appendix C). The Data 2 key is used to set the Note Off velocity (Velocity Off), and the Data 3 key is used to set the Note On velocity (Velocity On), determining how loud the note will sound.

Please refer to *Section 9 - Advanced Programming Functions*, for more details and step-by-step control assignment examples for different purposes.

Channel Assign

The Channel Assign function (CHAN ASGN) assigns a Knob, Slider, Button or the Sustain Pedal jack to a specific MIDI channel.

1. Select the control as described earlier in this guide.
2. Press the Advanced button
3. Press the Channel Assign key - the LED display will show the currently assigned MIDI channel for the active control (for example "c.0.2.")
4. Enter the new MIDI channel number using the number keys
5. Press the Enter key

When assigned to channel "0", the control (Knob, Slider, Button or Sustain Pedal jack) will transmit on the Global MIDI Channel. See the next section, "Global Channel" for more information.

NOTE: When a control is assigned to send SysEx messages, the displayed number represents the SysEx Device ID instead of the MIDI transmit channel number. Please refer to *Section 10 - MIDI Messages Defined for more information about SysEx messages, and Appendix B for a complete list of assignable SysEx messages.*

Global Channel

The Global Channel function (GLOBAL CHAN) sets the default MIDI channel for the keyboard and all MIDI controls, except for those that have a specific MIDI channel assigned to them.

1. Press the Advanced button
2. Press the Global Channel key - The LED display will show the current Global channel. For example if channel 1 is the current Global channel, it will appear as "c.0.1."
3. Enter the new channel number using the number keys
4. Press the Enter key

The Global Channel can also be changed by using the following method:

1. Press the Select button until the lower edge of the LED displays a red dot above "GLOBAL"
2. Scroll through the MIDI channels using the "-" or "+" buttons to select the new channel number

Program

This function sends Program Change MIDI messages on the Global Channel and can be used to select different sound patches contained within your virtual instrument or sound module.

1. Press the Advanced Function button
2. Press the Program key - the LED display will show the last sent program number (for example ".0.1.")
3. Enter the Program number
4. Press the Enter key to send the program change message

Program change messages can also be sent using the following method:

1. Press the Select button until the lower edge of the LED shows a red dot above "PGM"
2. Scroll through the Program numbers using the "-" or "+" buttons.

Bank LSB

The Bank LSB function sends bank change messages on the Global MIDI channel. These messages are used to access additional banks of sound patches on virtual instruments or sound modules (if additional banks are available).

Refer to the documentation for the virtual instrument or synthesizer to confirm it will respond to these messages.

1. Press the Advanced button
2. Press the Bank LSB key - the LED display will show the last sent Bank LSB number (for example ".0.1.")
3. Enter the new Bank LSB number using the number keys
4. Press the Enter key

NOTE: Bank LSB messages will not have any effect until they are followed by a Program Change message. See Section 10 - MIDI Messages Defined for more information.

Bank MSB

The Bank MSB function sends bank change messages on the Global MIDI channel. These messages are used to access additional banks of sound patches on virtual instruments or sound modules (if additional banks are available).

Refer to the documentation for the virtual instrument or synthesizer to confirm it will respond to these messages.

1. Press the Advanced button
2. Press the Bank MSB key - the LED display will show the last sent Bank MSB number (for example ".0.1.")
3. Enter the new Bank MSB number using the number keys
4. Press the Enter key

NOTE: Bank MSB messages will not have any effect until they are followed by a Program Change message. See section 10, MIDI Messages Defined for more information.

Panic

Press the Advanced button followed by the Panic key to send an "All Notes Off" message on all 16 MIDI channels. This stops any stuck notes that continue to play even after their keys have been released.

Velocity Curve

The Velocity Curve Select key (VEL CURVE) is used to change the touch sensitivity of the keyboard. This setting lets you decide how the force with which you hit a key affects the volume at which a note plays. Oxygen Series keyboards provide 7 different sensitivity options:

- 1 = **C1** is a sensitivity setting that generates lower velocity values for the same force. This setting is useful for playing more quietly, even if you tend to strike the keys harder.
- 2 = **C2** is the default setting, and is designed to be useful for most players with an "average" touch (people who play with an average amount of force).
- 3 = **C3** is a sensitivity setting that generates higher velocity values for the same force. This setting is useful for playing more loudly, even if you tend to strike the keys with less force.
- 4 = **C4** is a sensitivity setting that generates an equal velocity value for a given amount of force, resulting in a linear (or neutral) keyboard response.
- 5 = **F1** is a setting that effectively disables sensitivity, meaning the keyboard will generate a fixed velocity value of 64 (on a scale of 0-127) regardless of how hard or soft the keys are struck.
- 6 = **F2** is a setting that effectively disables sensitivity, meaning the keyboard will generate a fixed velocity value of 100 (on a scale of 0-127) regardless of how hard or soft the keys are struck.
- 7 = **F3** is a setting that effectively disables sensitivity, meaning the keyboard will generate a fixed velocity value of 127 (on a scale of 0-127) regardless of how hard or soft the keys are struck.

When a new Velocity Curve is selected using either method described below, the LED screen will show the first 4 Velocity curves as C1 - C4, and the three fixed velocity settings as F1 - F3.

1. Press the Advanced button
2. Press the Velocity Curve key - the LED display will show the current velocity curve (for example ".C.2")
3. Type the Velocity Curve number (1 through 7) using the number keys
4. Press the Enter key

- or -

1. Press the Advanced button
2. Press the Velocity Curve key - the LED display will show the current velocity curve (for example ".C.2")
3. Use the "-" and "+" buttons to scroll through the Velocity Curves (C1 through F3)
4. Press the Enter key

Drawbar Mode (Oxygen 49 and 61 only)

This parameter switches all 9 Sliders to Drawbar Mode. In this mode, the operation of the sliders is reversed, so that the maximum value (127) is at the bottom and the minimum value (0) is at the top.

This feature is intended for use with Organ presets that utilize drawbars.

1. Press the Advanced button
2. Press the Drawbar key - the LED screen will momentarily display "On"
Drawbar mode becomes active immediately and Advanced mode exits automatically

Repeat steps 1 and 2 to disable Drawbar mode. The LED screen will momentarily display "OFF"

Memory Dump

The SysEx Memory Dump function (MEM DUMP) will send the contents of all 10 Preset memory locations for storage in a DAW application. Please refer to the documentation provided with your DAW software for information on how to record SysEx MIDI data.

1. Prepare a MIDI track within your DAW software to record from your Oxygen keyboard
2. Press the Advanced button on your Oxygen keyboard
3. Start the MIDI recording in your DAW software
4. Press the Memory Dump key on your Oxygen keyboard. The SysEx memory dump will begin immediately and the LED will display "SYS" to indicate that data is being sent

The SysEx file will appear as a new MIDI recording in your DAW software.

Restoring a Memory Dump:

IMPORTANT: Restoring a saved Memory Dump will permanently overwrite all current presets on your Oxygen keyboard.

Play back a MIDI track that contains a previously recorded Oxygen SysEx Memory Dump. The SysEx data is sent back to the Oxygen keyboard. The Oxygen LED screen will display "SYS" while receiving the SysEx data.

NOTE: Restored settings will not become active until a new preset is loaded on your Oxygen keyboard, or the device has been powered off and on.

Device ID (Oxygen 49 and 61 only)

The Device ID function (DEV ID) allows the assignment of a unique SysEx Device ID to differentiate between multiple MIDI devices of the same model, when sending or receiving SysEx data.

The default setting of 127 lets the keyboard respond to all incoming SysEx messages compatible with the same type of Oxygen Series keyboard controllers. However, if the Device ID is changed to any other value, the keyboard will only respond to SysEx messages that contain the same Device ID number. This is useful in situations where multiple Oxygen controller keyboards are connected to the same DAW software and SysEx information needs to be sent to a specific keyboard controller with a unique Device ID number.

1. Press Advanced
2. Press the Device ID key - the LED screen will show the current Device ID (for example "1.2.7.")
3. Enter the new Device ID number using the number keys
4. Press the Enter key

NOTE: If the Device ID number of an Oxygen keyboard is changed after a Memory Dump was recorded into a DAW application, any attempts to restore it will be ignored because the numbers do not match. If you do not remember the Device ID number used when the Memory Dump was recorded, set your Oxygen keyboard to Device ID 127 to ensure all Memory Dumps will be recognized.

For more information on SysEx messages and Device ID numbers, please refer to *Section 10 - MIDI Messages Explained*.

Store

The Store function saves control assignment settings to one of 10 memory locations.

IMPORTANT: Storing new assignment settings will overwrite the contents of the selected memory location

1. Press the Advanced button
2. Press the Store key - the LED screen will show the number of the last selected memory location (for example P. 0.1.)
3. Enter the number of the memory location you want to store the new settings to by using the number keys or the - / + buttons
4. Press the Enter key to save the changes and overwrite the previous settings of the memory location

NOTE: The Oxygen Series factory presets can be restored by holding down the "-" and "+" buttons during power up.
IMPORTANT: This will permanently erase all customized user settings.

Number Keys

This section of the keyboard is used to type in numerical parameter values while in Advanced mode.

Enter Key

The Enter key confirms changes made and exits Advanced mode.

NOTE: The Panic, Drawbar and Memory Dump functions take immediate effect when the corresponding key is pressed. Advanced mode will exit automatically.

9 Advanced Programming Functions

The MIDI CC (continuous controller) numbers from 0 to 127 are part of the General MIDI specification, and are typically used for real-time control of parameters in MIDI compatible music equipment. For example, an Oxygen knob may be assigned to MIDI CC number 10, which controls the Pan setting of a connected synthesizer or DAW software track.

Many of the controls on Oxygen series keyboards are fully programmable, and can be assigned to any of these standard MIDI CC's. However, to simplify assignment of other, more complex MIDI message types (for example SysEx or RPN/NRPN), M-Audio has appended such additional MIDI message types to the end of the MIDI CC number list, extending it's range beyond 127. These additional messages can be assigned to Oxygen controls, just as if they were standard MIDI CC's, but using numbers in the range from 128 to 255, as listed in the tables in Appendix B.

Generally, this is achieved by selecting the control for editing and assigning a 3-digit number.

This section provides examples of the typical control assignment procedure for knobs, sliders, buttons and the sustain pedal jack. Assigning MIDI messages that are not explicitly mentioned in this section is done by using the same basic principle as given in the examples.

Appendix A lists the standard MIDI CC numbers from 0 to 127 and their corresponding General MIDI parameters.

Appendix B lists the additional, M-Audio specific MIDI assignment options (128 - 255), grouped by control type (sliders & knobs / buttons & sustain pedal jack), as well as their corresponding data type and purpose.

NOTE: Your Oxygen keyboard never transmits values outside the range specified by the MIDI protocol (0-127). The controller numbers from 128 - 255 are only used internally by your Oxygen keyboard. This simplifies configuration of the knobs, buttons and sliders when assigning advanced MIDI messages, and allows additional configuration options for the controls (for example, setting Trigger or Toggle operation of a button).

Setting Toggle Values (Min/Max) for Buttons or the Sustain Pedal

When standard MIDI CC numbers are assigned to buttons or the Sustain pedal, they will toggle between two values. This means that one value is sent the first time it is pressed, and another value is sent the next time it is pressed.

By default, the buttons on your Oxygen Series keyboard are already configured to operate as toggle switches. When configuring a button or the sustain pedal to operate in toggle mode, the following three values need to be specified:

Key	Parameter	Value
Control Assign (example)	MIDI CC number	10 (Pan)
Data 2 (example)	Second press	0 (minimum)
Data 3 (example)	First press	127 (maximum)

The following example will configure a button to "hard pan" the sound to the left speaker when it is pressed the first time, and "hard pan" to the right speaker when it is pressed a second time:

1. Select a button as described earlier in this guide
2. Press the Advanced button
3. Press the Control Assign key
4. Type 10 using the number keys. This assigns MIDI CC number 10 (Pan) to the button. See Appendix A
5. Press the Enter key
6. Press the Advanced button
7. Press the Data 2 key
8. Type 0 using the number keys to assign the "second button press" (minimum) value
9. Press the Enter key
10. Press the Advanced button
11. Press the Data 3 key
12. Type 127 using the number keys to assign the "first button press" (maximum) value
13. Press the Enter key

TIP: It can be useful to transmit two other specific values instead of sending minimum (zero) and maximum (127) values as in the above example. When assigning a button to control Pan (MIDI CC 10), you can, for example, configure Data 2 to send value 38, and Data 3 to send value 93, effectively causing pan to switch between the approximate "ten o'clock" and "two o'clock" positions when pressing the button repeatedly.

NOTE: If you want the button to send the same value every time it is pressed, enter the same value for both the Data 2 and Data 3 parameters.

Setting Trigger Values for the Buttons or the Sustain Pedal

It is possible to set a Trigger Value for a button or the sustain pedal, causing it to send one value when pressed and held down, and another value when released.

The sustain pedal is already configured to send trigger values by default, ensuring it activates the sustain effect when pressed and deactivates it when the pedal is released. Buttons can also be configured to operate this way, which requires four values to be specified. At the example of the sustain pedal, these four values are:

Key	Parameter	Value
Control Assign	Trigger On/Off operation	146
Data 1 (example)	MIDI CC number	64 (Sustain)
Data 2 (example)	Button/Pedal Released	0 (minimum)
Data 3 (example)	Button/Pedal Pressed	127 (maximum)

NOTE: When working with proprietary M-Audio parameters from the 128-255 range, the "Control Assign" setting is used to configure a button or the sustain pedal for this special mode of operation. This means that certain values that are usually specified through the "Control Assign" setting must instead be specified via the "Data 1" parameter (such as the standard MIDI CC parameter in the example below).

The following example will configure a button to "hard pan" the sound to the right speaker when it is held down, and "hard pan" to the left speaker when it is released. This involves configuring the button to operate as a trigger, while controlling the Pan parameter (MIDI CC 10):

1. Select a button as described earlier in this guide
2. Press the Advanced button
3. Press the Control Assign key
4. Type 146 using the number keys. This configures the button to operate as a trigger (press/release). See Appendix B
5. Press the Enter key
6. Press the Advanced button
7. Press the Data 1 key
8. Type 10 using the number keys. This specifies which parameter the button will trigger and release. In this example, MIDI CC 10 (Pan). See Appendix A
9. Press the Enter key
10. Press the Advanced button
11. Press the Data 2 key
12. Type 0 using the number keys. This sets the "release" value to zero. In other words, sound will be panned "hard left" when the button is released.
13. Press the Enter key
14. Press the Advanced button
15. Press the Data 3 key
16. Type 127 using the number keys. This sets the "press" value to the maximum value, so that the sound is panned hard right when the button is pressed.
17. Press the Enter key

TIP: It can be useful to transmit two other specific values instead of sending minimum (zero) and maximum (127) values as in the above example. When assigning a button to control Pan (MIDI CC 10), you can, for example, configure Data 2 to send value 38, and Data 3 to send value 93, effectively causing pan to switch between the approximate "ten o'clock" and "two o'clock" positions when pressing and releasing the button.

Assigning MMC Control to Buttons

The transport functions of some hardware recording devices and DAW applications can be remotely operated via MMC (MIDI Machine Control) commands. MMC is a specialized transport control protocol and requires a somewhat different configuration method.

The following values need to be specified:

Key	Parameter	Value
Control Assign	MMC Control	149
Channel Assign (example)	Device ID	127
Data 2 (example)	MMC Function	2 (Play)

The following example will configure a button to send the MMC command "Play":

1. Select an assignable button described earlier in this guide
2. Press the Advanced button
3. Press the Control Assign key
4. Type 149 using the number keys. This sets the button to send MMC (MIDI Machine Control)
5. Press the Enter key
6. Press the Advanced button
7. Press the Channel Assign key
8. Enter 127 (Poly On) using the number keys. This ensures all receiving devices will respond to the MMC messages
9. Press the Enter key
10. Press the Advanced button
11. Press the Data 2 key
12. Enter a number from the chart below to select the MMC command for the button. This determines which transport function will be controlled by this button. For example, enter "2" for the Play command
13. Press the Enter key

Number	MMC Command
01	STOP
02	PLAY
03	DEFERRED PLAY
04	FAST FORWARD
05	REWIND
06	RECORD STROBE
07	RECORD EXIT
08	RECORD PAUSE
09	PAUSE
09	EJECT
10	CHASE
11	COMMAND ERROR RESET
12	MMC RESET

Assigning a Note to a Button

It is possible to configure a Button to send a Note On message when it is held down, and a Note Off message when it is released.

This requires four values to be specified (values given are examples):

Key	Parameter	Value
Control Assign	Trigger Note On/Off	147
Data 1 (example)	Note pitch	64 (E4 - see Appendix C)
Data 2 (example)	Note off velocity	0
Data 3 (example)	Note on velocity	100

The following example configures a button to play MIDI note E4 while it is being held down and stop the note when the button is released.

1. Select a button as described earlier in this guide
2. Press the Advanced button
3. Press the Control Assign key
4. Enter 147 using the number keys. This sets the button to trigger MIDI Notes (see Appendix B)
5. Press the Enter key
6. Press the Advanced button
7. Press the Data 1 key (Pitch/Note parameter)
8. Enter "64" using the number keys. This sets the button to play MIDI note 64 (E4 - see Appendix C)
9. Press the Enter key
10. Press the Advanced button
11. Press the Data 2 key (Velocity Off)
12. Enter 0 using the number keys. This sets the button to transmit a Note Off message with a release velocity value of zero.
13. Press the Enter key
14. Press the Advanced button
15. Press the Data 3 key (Velocity On)
16. Enter 100 using the number keys. This sets the button to transmit a Note On message with a velocity of 100 when pressed
17. Press the Enter key

NOTE: It is also possible to configure a button to send a note on message when it is pressed and a note off message when it is pressed a second time. To do this, follow the above configuration steps, but enter 148 for the "Control Assign" parameter (see Appendix B).

Setting Buttons to send combined Program Change, Bank LSB and Bank MSB messages

The assignable buttons and the sustain pedal can be configured to send a multi-part message, consisting of a Program Change, Bank LSB and Bank MSB message when pressed. This is useful for specific patch/sound selection from a specific bank of a connected synthesizer or virtual instrument.

This requires four values to be specified (values given are examples):

Key	Parameter	Value
Control Assign	Program/Bank Preset select	145
Data 1 (example)	Program Change Number	42 (GM Instrument Cello - see Appendix C)
Data 2 (example)	Bank LSB number	8
Data 3 (example)	Bank MSB number	32

The following example configures a button to send a total of 3 MIDI messages each time the button is pressed (Bank LSB, Bank MSB and Program Change), allowing you to recall any sound in any bank of a connected software or hardware synthesizer that supports this:

1. Select the Control as described earlier in this guide (Button or Pedal)
2. Press the Advanced button
3. Press the Control Assign key
4. Enter 145 using the number keys. This sets the button or the pedal to send a combined Bank Select/Program Change message
5. Press the Enter key
6. Press the Advanced button
7. Press the Data 1 key
8. Enter the Program Change number, for example 42
9. Press the Enter key
10. Press the Advanced button
11. Press the Data 2 key
12. Enter the Bank LSB number, for example 8
13. Press the Enter key
14. Press the Advanced button
15. Press the Data 3 key
16. Enter the Bank MSB number, for example 32
17. Press the Enter key

See *Section 10 - MIDI Messaged Defined* for an in-depth explanation of how Bank LSB / Bank MSB and Program Change messages work together to access all programs on a connected synthesizer or other MIDI device.

Programming a Button to Increment/Decrement a MIDI CC value

It is possible to configure a button to increase or decrease a value each time it is pressed. This is useful if you want to step through values one by one each time a button is pressed.

To configure a button to increment a MIDI CC between a minimum and maximum value, assign the button to number 154 (see Appendix B). The minimum and maximum values are set using the Data 2 and Data 3 parameters respectively.

This requires four values to be specified (values given are examples):

Key	Parameter	Value
Control Assign	Increment MIDI CC	154
Data 1 (example)	MIDI CC number	72 (Release Time)
Data 2 (example)	Low Limit	0
Data 3 (example)	High Limit	127

The following example configures a button to increment the release time of the currently active MIDI instrument sound patch every time the button is pressed (you may have to push the button several times while playing notes to hear a difference).

1. Select the Control as described in this guide (Button or Pedal)
2. Press the Advanced button
3. Press the Control Assign key
4. Enter 154 using the number keys. This sets the button or the pedal to increment the MIDI CC value
5. Press the Enter key
6. Press the Advanced button
7. Press the Data 1 key
8. Enter "72" using the number keys. This specifies the MIDI CC for which values will be incremented
9. Press the Enter key
10. Press the Advanced button
11. Press the Data 2 key
12. Enter 0 using the number keys. This specifies the minimum value
13. Press the Enter key
14. Press the Advanced button
15. Press the Data 3 key
16. Enter 127 using the number keys. This specifies the maximum value
17. Press the Enter key

To configure a button to decrement (decrease) a MIDI CC value, assign the button to number 153 (see Appendix B). The minimum and maximum value (range) for each button is set using the Data 2 and Data 3 parameters respectively.

NOTE: Each button will only increment or decrement its own parameter value and this value is independent of any other button. In other words, assigning one button to increment a parameter and another button to decrement the same parameter will cause the first button to send values such as 1, 2, 3, etc., each time the button is pressed. Pressing the second button will send values such as 127, 126, 125 (as opposed to starting to decrement where the first button left off; for example 2, 1, 0).

Programming a Button to Increment/Decrement a Program Change

It is possible to configure a button to send an Increment (increase) or Decrement (decrease) Program Change message each time it is pressed.

To configure a button to increment a Program Change between a minimum and maximum value, assign the button to number 156 (see Appendix B). The minimum and maximum values are set using the Data 2 and Data 3 parameters respectively.

The requires three values to be specified (values given are examples):

Key	Parameter	Value
Control Assign	Program Increment	156
Data 2 (example)	Program Number (minimum)	0
Data 3 (example)	Program Number (maximum)	127

The following example configures a button to increment through the sound patches on a connected software or hardware synthesizer:

1. Select the Control as described in this guide (Button or Pedal)
2. Press the Advanced button
3. Press the Control Assign key
4. Enter 156 using the number keys. This configures the button to increment the Program number
5. Press the Enter key
6. Press the Advanced button
7. Press the Data 2 key
8. Enter 0 using the number keys. This specifies the lowest Program number
9. Press the Enter key
10. Press the Advanced button
11. Press the Data 3 key
12. Enter 127 using the number keys. This specifies the highest Program number
13. Press the Enter key

To configure a button to decrement a Program Change between a maximum and minimum value, assign the button to number 155 (see Appendix B). The minimum and maximum values are set using the Data 2 and Data 3 parameters respectively.

NOTE: Each button will only increment or decrement its own parameter value and this value is independent of any other button. In other words, assigning one button to increment through sound patches and another button to decrement through sound patches will cause the first button to recall programs 1, 2, 3, etc., each time the button is pressed. Pressing the second button will recall programs such as 127, 126, 125 (as opposed to starting to decrement where the first button left off; for example 2, 1, 0).

Reversing the operation of Knobs or Sliders

Most MIDI parameters assignable to knobs or sliders can be configured so that the control's operation is reversed. Once a control is assigned to a MIDI parameter, by default the Data 2 parameter defines the minimum value (for example zero) while the Data 3 parameter defines the maximum value to be transmitted (for example 127). Reversing the operation of Knobs or Sliders is achieved by entering a higher value for the Data 2 parameter (usually minimum) and a lower value for the Data 3 parameter (usually maximum).

This is useful when a single Slider needs to be configured to work as a drawbar, or if a knob needs to be configured in reverse when controlling a particular parameter.

This requires two values to be specified (values given are examples):

Key	Parameter	Value
Data 2 (example)	Minimum Value	127
Data 3 (example)	Maximum Value	0

The following example configures a button or slider to reverse its operation:

1. Select a Knob or Slider as detailed earlier in this guide
2. Press the Advanced button
3. Press the Data 2 key
4. Enter 127 using the number keys. This configures the control to reach its maximum value when it is all the way down
5. Press the Enter key
6. Press the Advanced button
7. Press the Data 3 key
8. Enter 0 using the number keys. This configures the control to reach its minimum value when it is all the way up
9. Press the Enter Key

The Knob or Slider now operates reversed. What was originally the maximum position, is now the minimum position, and vice versa.

Limiting the Range of a Knob or Slider

The MIDI protocol allows for a maximum range of transmitted values between 0 and 127. The effective range of values transmitted by Knobs and Sliders can be limited by entering values other than 0 and 127 (default) for the Data 2 and Data 3 parameters.

For example with the Data 2 parameter set to 38 and Data 3 set to 93, if a knob is set fully counter-clockwise, the lowest value it transmits is 38. If the knob is turned fully clockwise, the highest value it transmits is 93. This can be useful in a variety of scenarios, for example to keep a knob within the "sweet spot" of a synthesizer parameter (for example, filter cutoff), or to quickly recall a specific minimum or maximum volume setting for a track.

Key	Parameter	Value
Control Assign (example)	MIDI CC number	07 (Volume)
Data 2 (example)	Minimum Value	38
Data 3 (example)	Maximum Value	93

The following example configures a knob or slider to operate within a limited range (38 to 93):

1. Select a a Knob or Slider as described earlier in this guide
2. Press the Advanced button
3. Press the Control Assign key
4. Type 7 using the number keys. This assigns MIDI CC number 7 (Volume) to the knob or slider. See Appendix A
5. Press the Enter key
6. Press the Advanced button
7. Press the Data 2 key
8. Type 38 using the number keys
9. Press the Enter key
10. Press the Advanced button
11. Press the Data 3 key
12. Type 93 using the number keys
13. Press the Enter key

NOTE: The operation of knobs and sliders can be reversed, even if the range of operation is limited. This is achieved by entering a higher value for the Data 2 parameter and a lower value for the Data 3 parameter.

Assigning RPN/NRPN messages to a Knob, Slider, Button, or Pedal

Oxygen Series keyboards allow transmission of all three necessary MIDI CC messages for RPNs and NRPNs by simply moving a knob or slider or by pressing a button or the sustain pedal.

The "Control Assign" setting allows assignment for control of the RPN Coarse (132) and RPN Fine (133), as well as NRPN Coarse (134) and NRPN Fine (135) parameters (see *Section 10 - MIDI Messages Defined* and *Appendices A & B* for more information).

The Data 1 setting lets you specify which MIDI CC number is sent to alter values (usually: Coarse=CC 6; Fine=CC 38). The Data 2 setting defines what value is sent for LSB (RPN: CC 100, NRPN: CC 98) while the Data 3 setting defines which value is sent for MSB (RPN: CC 101, NRPN: CC 99). Together, the LSB and MSB values specify the RPN/NRPN parameter to be edited.

Assigning a knob to control an RPN/NRPN on a connected hardware or software device requires four values to be specified.

Key	Parameter	Value
Control Assign	NRPN Coarse	134
Data 1 (example)	CC for Value Change	6
Data 2 (example)	CC 98 / LSB	51
Data 3 (example)	CC 99 / MSB	3

The following example assigns a manufacturer specific NRPN coarse (134) message to a control on your Oxygen keyboard:

1. Select a Knob or Slider as described earlier in this guide
2. Press the Advanced button
3. Press the Control Assign key
4. Enter 134 (NRPN Coarse) using the number keys (see *Appendices B and F*)
5. Press the Enter key
6. Press the Advanced button
7. Press the Data 1 key
8. Enter 6 using the number keys (or the MIDI CC number for value changes as required by your device)
9. Press the Advanced button
10. Press the Data 2 key
11. Enter the value to be transmitted via MIDI CC 98 (LSB) using the number keys
12. Press the Enter key
13. Press the Advanced button
14. Press the Data 3 key
15. Enter the value to be transmitted via MIDI CC 99 (MSB) using the number keys
16. Press the Enter key

See *Section 10 - MIDI Messages Defined* for an in-depth explanation of RPN/NRPN MIDI messages and their usage.

SysEx Messages and Device ID

When transmitting SysEx messages, the individual control channel number does not define a transmit channel, but a Device ID. When the CHAN ASGN key is pressed, the "c" is not displayed on the LED screen.

Device ID's range between 0-127. In most cases, the Device ID should be set to 127 so that all devices will receive the SysEx message.

The Device ID for a SysEx message assigned to a controller cannot be changed using the Device ID key. This key is used for varying the global Device ID of an Oxygen Series keyboard.

For more information, please refer to the *SysEx Messages* and *Device ID* sections.

Non-Volatile Memory

All Oxygen keyboards feature non-volatile memory, which allows for automatic saving of presets when the device is powering down. The current controller and channel assignments are stored even if the Save function has not been used. The Program, Bank LSB and Bank MSB data, Global Channel setting, and last used memory preset are also stored.

Restoring the Factory Settings

Factory default settings can be restored by holding down the - and + buttons during power-up. At this point all previously saved data will be erased.

10 MIDI Messages Defined

Program and Bank Changes

When the MIDI standard was first established, it enabled the user to access only 128 different sounds using program change messages (0-127). As MIDI devices became more sophisticated and contained more sounds, bank change messages were included in an updated MIDI specification allowing access to more than 128 sounds. The language MIDI uses to communicate between musical instruments only allows for program change commands 0-127, for a total of 128 possible programs (127 programs + program "0" = 128 programs total). Due to inherent limitations of the MIDI communication protocol, the number of directly accessible programs (using program change messages) cannot easily be expanded beyond 128. Thus, a system of banks, with 128 sounds in each, has been created that enables manufacturers to overcome the 128-sound MIDI limit.

128 banks with 128 sounds in each bank is the basic principle used to expand the number of accessible sounds. However, to avoid reaching the new limit of the resulting 16,384 possible sounds (128 banks x 128 programs) accessible using a bank change combined with a program change, another layer of banks was added. The result is a system of 128 banks that can contain 128 sub-banks in each of them, which, in turn, can contain 128 sounds (programs).

Bank change messages are useful when calling up sounds from a large library that may exist in a particular sound module or software synthesizer. For example, devices that are built according to Roland's GS specification or Yamaha's XG specification (*Appendix E*) require you to specify a bank change in order to access the extra voices that these devices provide. MIDI CC 0 is the bank select MSB (Most Significant Byte) message. This MIDI message is 7-bit in size and can be used to select any of 128 banks.

This message can be used in conjunction with MIDI CC 32 which is bank select LSB (Least Significant Byte): a separate 7-bit message allowing additional selection of any of another 128 sub-banks. The combination of Bank MSB and LSB messages gives a 14-bit message that can select any of a possible 16,384 banks. Each bank can in turn contain 128 possible sounds selected via a separate program change MIDI message. This enables a user to theoretically recall over two million programs directly, using only MIDI commands. However, most devices only use a few different banks, and you can often ignore the LSB message.

You will find many MIDI devices respond to program change commands and many are organized according to the GM listing. In General MIDI devices, different sounds are organized in the same way from device to device. Piano sounds are in their particular place, string sounds are in their place, drum sounds are in their place, and so on. All GM devices (both hardware and software sound modules) are clearly labeled as such, so you know that their sounds are organized in the General MIDI structure. When a GM device receives a MIDI program change, it calls up a type of sound that you expect from the GM sound set. All non-GM MIDI sound modules call up unique sounds from their memory upon receiving MIDI program changes. Since the sounds in a non-GM device are not arranged in a particular order, you need to take a look at the device itself to see which sound you want and at which location in the memory it resides. Many VST instruments such as Native Instruments' FM7 or the synth modules in Propellerheads Reason are non-GM devices.

You can send Program Change, Bank LSB and Bank MSB messages directly from your Oxygen Series keyboard.

Please consult the documentation for your sound module, DAW or software instrument for further information.

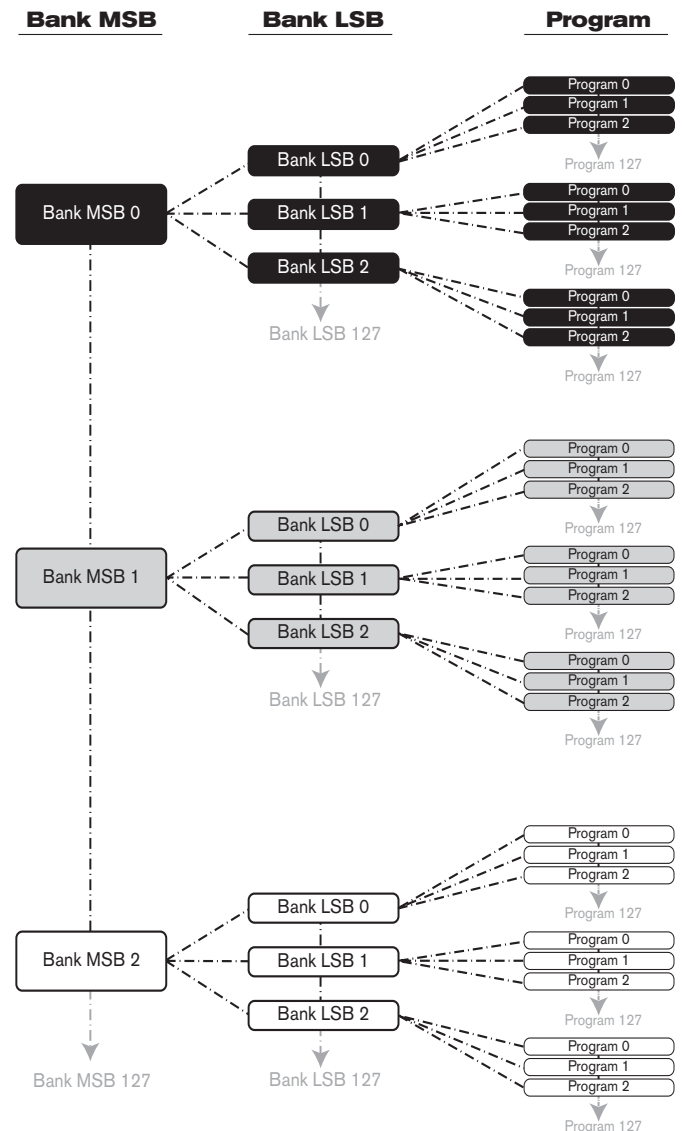

RPN/NRPN's

Overview

RPN stands for "Registered Parameter Number" and NRPN stands for "Non-Registered Parameter Number". Non-registered parameter numbers (NRPN's) are device-specific messages that enable you to control specific synthesizer or sound module parameters via MIDI, that are not accessible via standard MIDI CCs. The MIDI specification defines open parameter numbers to allow manufacturers to specify their own NRPN controllers.

The more common of these are registered by the MIDI Manufacturer's Association and are now part of the MIDI specification, hence the term Registered Parameter Numbers – RPN's (See Appendix A). Each NRPN/RPN has an associated 2-byte number. The two bytes allow for 128 values each. An RPN or NRPN message is made up of two parts: The MSB and the LSB message. Both of these messages together constitute an RPN or NRPN command. This allows for 16,384 values in total. MIDI controllers 98 and 99 represent the NRPN LSB and MSB respectively, while 100 and 101 represent the RPN LSB and MSB messages (see the MIDI controllers list in Appendix A).

To transmit an NRPN/RPN message, these LSB and MSB controller messages are sent along with their user-specified values. A further controller message and value needs to be sent to specify the (coarse or fine) value adjustment. This is specified by controller number 6 (data entry) for coarse adjustments or number 38 for fine adjustments.

A list of NRPN's is usually given in the user's manual of any device that receives NRPN messages. It is always necessary that the NRPN MSB and LSB be sent together. Both will be specified in the device's manual, but typically only in Hexadecimal format. If this is the case, you may refer to Appendix C for help translating the value to decimal.

Combining Two MIDI CC Numbers for 16,384 possible RPNs/NRPNs

A single MIDI CC provides 128 values or possible selections - not enough to provide a sufficient number of unique RPN/NRPNs for all manufacturers of MIDI equipment. In order to make a large enough number of RPN and NRPN messages available for use by the many manufacturers of MIDI devices, two specific MIDI CC numbers (NRPN=98+99; RPN=100+101) are combined for RPN/NRPN selection. When combining two MIDI CC numbers this way, the 128 possibilities of the first MIDI CC multiply with the 128 possibilities of the second MIDI CC, resulting in 16384 unique possibilities - plenty of options for all manufacturers of MIDI equipment.

You can think of this as a matrix of 128x128 options, each representing a unique identifier a manufacturer of MIDI equipment may choose to use for selection of a specific parameter in their device. See the illustration below.

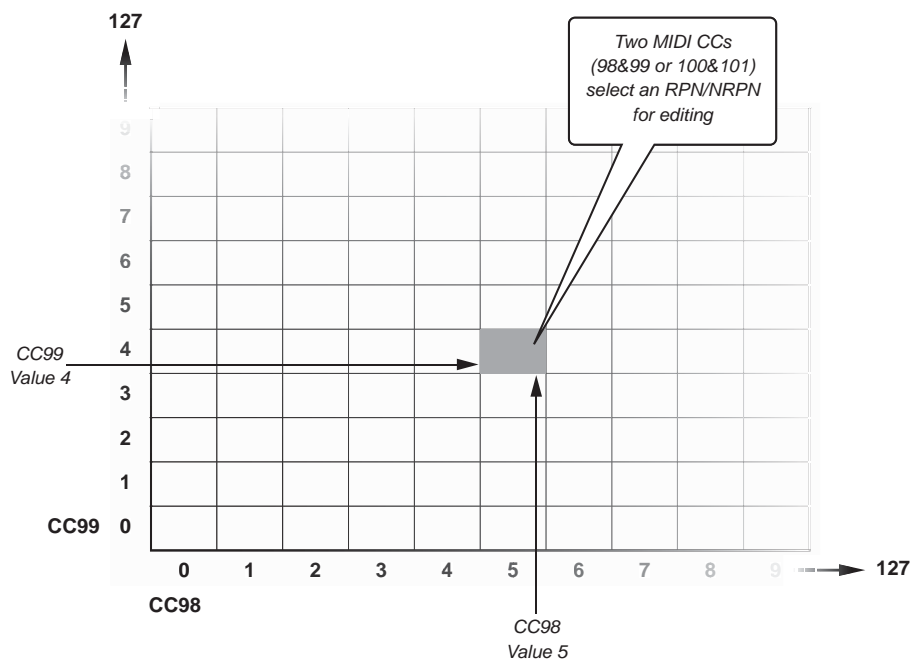

Check your 3rd Party Documentation for a RPN/NRPN List

Begin by checking the documentation for your MIDI device for a list of supported RPN or NRPN numbers. As mentioned, the supported parameters are unique to the device in use but the list should look similar to this:

	MIDI CC98	MIDI CC99	MIDI CC6
Filter Cutoff	41	3	0-127
Resonance	41	4	0-127
Attack	41	5	0-127
Decay	41	6	0-127
Sustain	41	7	0-127
Release	41	8	0-127
LPF	41	9	0-127
HPF	41	10	0-127

Find the parameter you wish to control from the list in the 3rd party manufacturer's documentation and make note of the values listed for CC 98 (LSB) and for CC 99 (MSB) when working with NRPNs, or CC 100 (LSB) and CC 101 (MSB) when working with RPNs. You will need these values once you are ready to assign an Oxygen control to an RPN or NRPN.

A Third MIDI CC Number (CC 6 or CC 38) for Altering the RPN or NRPN Value

A third MIDI CC is needed to change the value of the selected RPN or NRPN. For most devices, MIDI CC 6 is used when working with NRPN or RPN "coarse" messages, while MIDI CC 38 is used when working with "fine" messages. In other words, the combined MIDI CC numbers (NRPN=98+99; RPN=100+101) only specify the parameter to be edited. They have to be followed with yet another specific MIDI CC number/value (CC 6 or CC 38) in order to alter the associated parameter value.

This means that 3 MIDI messages have to be sent in sequence, in order to select, and then change a RPN or NRPN value. For example:

MIDI CC 98: value 51
 MIDI CC 99: value 3 } Selects a specific NRPN

MIDI CC 6: value 10 → Sets the parameter to a value of 10.

16,384 step resolution through combined Coarse and Fine messages

Most assignable MIDI controls, including those on your Oxygen series keyboard, operate with a resolution of 128 steps. Standard MIDI CC messages that can be used universally between different MIDI devices are also limited to a resolution of 128 steps. However, the RPN/NRPN concept allows for a resolution of 16,384 steps by combining two 7-bit MIDI messages into a 14-bit message (coarse + fine).

Hardware controller knobs or sliders that take advantage of the full 14-bit RPN/NRPN resolution are very uncommon. To illustrate the concept and make the purpose of RPN/NRPN Coarse and Fine messages easier to understand, we included a graphic describing how such a 14-bit RPN/NRPN control would operate (not supported by Oxygen Series keyboards):

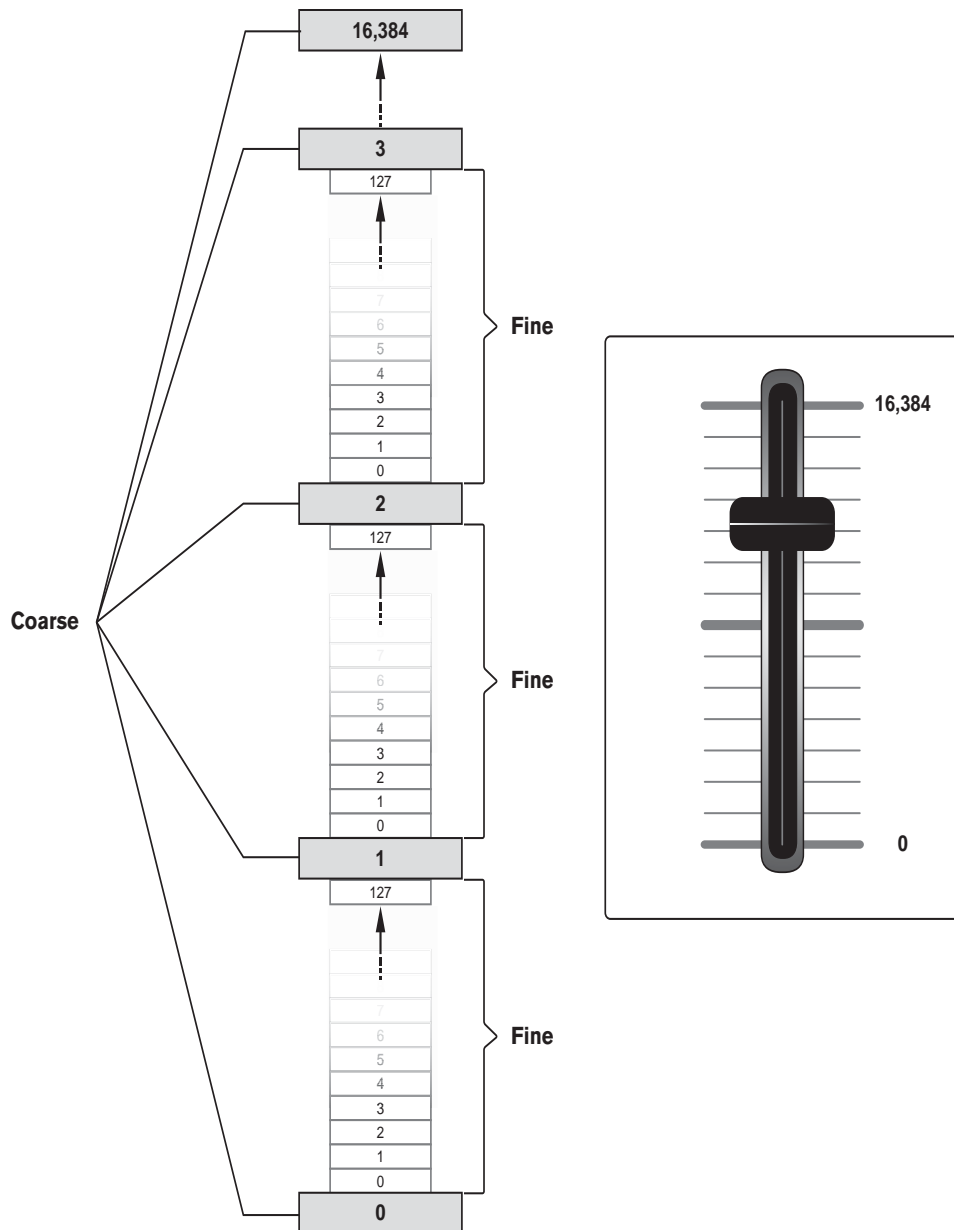

The RPN/NRPN coarse message divides the range of 16384 steps into 128 segments and activates them by sending each segment's first value, while the RPN/NRPN fine message provides the 128 steps of resolution contained in each of these segments.

The controls on your Oxygen keyboard allow assignment of either a RPN/NRPN coarse message, or a RPN/NRPN fine message, but not both simultaneously. In practical use, this means:

- ▶ Assigning an RPN/NRPN coarse message to an Oxygen control allows to access values throughout the entire range of 16384 steps while skipping 128 steps with every value transmitted (0; 129; 258; 387; 516; 645; ... ;16384).
- ▶ Assigning an RPN/NRPN fine message to an Oxygen control allows access to the first 128 values of the entire range (0-127 of 16384).

In most cases, it is preferable to assign the RPN/NRPN coarse message, unless two Oxygen controls are dedicated to be operated together for simultaneous controls of the RPN/NRPN coarse and fine parameters.

Many data sheets for synthesizers make use of NRPN messages and will give the LSB and MSB values that should be entered for Data 2 and Data 3. Some manuals may only give the hex values, but Oxygen requires the decimal value to be entered. See Appendix E for a hex to decimal conversion chart.

SysEx

System Exclusive (SysEx) messages were defined in the MIDI specification to allow control of individual devices via MIDI. The format of SysEx messages allows virtually any function to be performed via MIDI if the receiving device can read and translate the message. This allows devices to send audio sample memory data, memory dumps, controller settings, and much more. It also allows the controllers of one device to be controlled by another.

It is not possible to program your own specified SysEx message into the Oxygen controller. However, several useful SysEx messages are pre-programmed into the keyboard. They can be accessed by assigning the appropriate MIDI controller number to a control (see *Appendix A*).

A SysEx message is not transmitted on any specific channel. All SysEx messages contain a Device ID, which is used to single out devices to respond to the SysEx message. All other devices are ignored. If you are using a SysEx message with your Oxygen keyboard, the Global Channel is ignored. When you press the Channel Assign key, you will enter a Device ID instead. This is indicated by the fact that the LED displays a 3-digit number, not a 2-digit number preceded by a "c."

Device IDs run from 00 to 127. 127 is the default device number setting on the Oxygen keyboard controller. This setting transmits the SysEx message to all devices.

It is not possible to program the controls on your Oxygen keyboard with your own SysEx messages, there are software applications that can receive a MIDI input signal and translate it into a different, user-specified message. You can program your custom SysEx messages into the translator software, and then translate the incoming data from the keyboard to your custom SysEx message.

11 Troubleshooting

▶ **Oxygen keyboard suddenly stops working.**

Turn off the unit for 10 seconds, then restart your computer and power up the keyboard. If the problem persists, check the M-Audio website for the latest drivers and re-install them.

▶ **The keyboard is connected to my computer with the USB cable, but I cannot locate my Oxygen keyboard in my software's MIDI devices dialog box.**

Your Oxygen keyboard may not be receiving enough USB bus power to function correctly. Try plugging it into a different USB port or a powered USB hub connected to your computer.

In Windows XP, the Oxygen MIDI ports will appear as "USB Audio Device" if the optional drivers *have not* been installed. Select "USB Audio Device" as your audio and MIDI input and output device.

Please refer to Chapter 5 of this guide for instructions on how to install the Oxygen Series Drivers.

▶ **The Oxygen keyboard does not trigger sounds in my music software.**

Most programs have a MIDI activity indicator that can be used to confirm whether MIDI data from the keyboard is reaching the software. If the software is not receiving any MIDI data, be sure the controller is properly installed and is selected as a MIDI input device within your software. Refer to the documentation for your DAW software, to learn how to configure and select MIDI input devices.

If the MIDI activity display indicates that MIDI data is reaching your software, then you may not be hearing sounds because the MIDI data is not being routed correctly through the software itself. Refer to the documentation for your DAW software, to learn how to route MIDI data properly.

▶ **When playing a virtual instrument loaded in my music software, there is a noticeable delay before I hear any sound.**

This delay is known as latency, and it may be possible to reduce it through the Control Panel of your audio interface. Please refer to your audio interface's User Guide to see if this is possible.

▶ **I have connected a sustain pedal to my Oxygen keyboard, but its operation is reversed (i.e., the notes sustain when the pedal isn't pressed, but the notes stop sustaining once the pedal is pressed).**

The polarity of the sustain pedal is determined by the keyboard upon startup. When the keyboard is powering up, the sustain pedal is assumed to be in the "up" (off) position. It is important that the sustain pedal is not pressed down during startup, otherwise its operation may be reversed.

▶ **My virtual instrument software (or hardware MIDI module) always recalls the sound next to the program change number that I have sent to it from my Oxygen keyboard. For example, if I send a program change number 40 (Violin), my MIDI module or software loads sound number 41 (Viola).**

This behavior is normal. Some MIDI devices count their sound presets from 1-128 instead of 0-127. As a result, there may be an offset of +/-1 between the program change number sent from the keyboard and the recalled sound preset on your module.

▶ **I have changed many parameters and would like to go back to the keyboard's default settings.**

Oxygen Series keyboards can be reset to their "factory" settings by simultaneously pressing the "+" and "-" buttons as the unit is switched on.

NOTE: All assignments and modified patches will be lost once you perform this action—use this function with caution!

12 Technical Info

Caution: Electro Static Discharge, Electrical Fast Transient and Conducted RF interference may cause the unit malfunctioning. In such case, unplug the unit and plug it in again to restore normal operation.

Note: Your M-Audio product has been tested to comply with FCC Standards FOR HOME OR OFFICE USE. Modifications not authorized by the manufacturer may void users authority to operate this device.

Note: This equipment has been tested and found to comply with the limits for a Class B digital device, pursuant to Part 15 of the FCC Rules. These limits are designed to provide reasonable protection against harmful interference in a residential installation. This equipment generates, uses and can radiate radio frequency energy and, if not installed and used in accordance with the instructions, may cause harmful interference to radio communications. However, there is no guarantee that interference will not occur in a particular installation. If this equipment does cause harmful interference to radio or television reception, which can be determined by turning the equipment off and on, the user is encouraged to try to correct the interference by one or more of the following measures:

- ▶ Re-orient or relocate the receiving antenna.
- ▶ Increase the separation between the equipment and receiver.
- ▶ Connect the equipment to an outlet on a circuit different from that to which the receiver is connected.
- ▶ Consult the dealer or an experienced radio/ TV technician for help.

ASIO is a trademark of Steinberg Soft- und Hardware GmbH.

VST is a trademark of Steinberg Soft- und Hardware GmbH

13 Warranty Terms and Registration

Warranty Terms

M-Audio warrants products to be free from defects in materials and workmanship, under normal use and provided that the product is owned by the original, registered user. Visit www.m-audio.com/warranty for terms and limitations applying to your specific product.

Warranty Registration

Immediately registering your new M-Audio product entitles you to full warranty coverage and helps M-Audio develop and manufacture the finest quality products available. Register online at www.m-audio.com/register to receive FREE product updates and for the chance to win M-Audio giveaways.

Documentation Feedback

At M-Audio, we are always looking for ways to improve our documentation. If you have comments, corrections, or suggestions regarding our documentation, e-mail us at publications@m-audio.com



WARNING: This product contains chemicals, including lead, known to the State of California to cause cancer, and birth defects or other reproductive harm. **Wash hands after handling.**

©2009 Avid Technology, Inc. All rights reserved. Product features, specifications, system requirements and availability are subject to change without notice. Avid, M-Audio and Oxygen are either trademarks or registered trademarks of Avid Technology, Inc. All other trademarks contained herein are the property of their respective owners.

14 Appendix

Appendix A: Standard MIDI Control Numbers (MIDI CC's)

00 Bank Select	46 Controller 46	92 Tremolo Depth
01 Modulation	47 Controller 47	93 Chorus Depth
02 Breath Control	48 Gen Purpose 1 LSB	94 Celeste (De-tune)
03 Controller 3	49 Gen Purpose 2 LSB	95 Phaser Depth
04 Foot Control	50 Gen Purpose 3 LSB	96 Data Increment
05 Porta Time	51 Gen Purpose 4 LSB	97 Data Decrement
06 Data Entry	52 Controller 52	98 Non-Reg Param LSB
07 Channel Volume	53 Controller 53	99 Non-Reg Param MSB
08 Balance	54 Controller 54	100 Reg Param LSB
09 Controller 9	55 Controller 55	101 Reg Param MSB
10 Pan	56 Controller 56	102 Controller 102
11 Expression	57 Controller 57	103 Controller 103
12 Effects Controller 1	58 Controller 58	104 Controller 104
13 Effects Controller 2	59 Controller 59	105 Controller 105
14 Controller 14	60 Controller 60	106 Controller 106
15 Controller 15	61 Controller 61	107 Controller 107
16 Gen Purpose 1	62 Controller 62	108 Controller 108
17 Gen Purpose 2	63 Controller 63	109 Controller 109
18 Gen Purpose 3	64 Sustain Pedal	110 Controller 110
19 Gen Purpose 4	65 Portamento	111 Controller 111
20 Controller 20	66 Sostenuto	112 Controller 112
21 Controller 21	67 Soft Pedal	113 Controller 113
22 Controller 22	68 Legato Pedal	114 Controller 114
23 Controller 23	69 Hold 2	115 Controller 115
24 Controller 24	70 Sound Variation	116 Controller 116
25 Controller 25	71 Resonance	117 Controller 117
26 Controller 26	72 Release Time	118 Controller 118
27 Controller 27	73 Attack Time	119 Controller 119
28 Controller 28	74 Cut-off Frequency	Channel Mode Messages
29 Controller 29	75 Controller 75	120 All Sound off
30 Controller 30	76 Controller 76	121 Reset all Controllers
31 Controller 31	77 Controller 77	122 Local Control
32 Bank Select LSB	78 Controller 78	123 All Notes Off
33 Modulation LSB	79 Controller 79	124 Omni Off
34 Breath Control LSB	80 Gen Purpose 5	125 Omni On
35 Controller 35	81 Gen Purpose 6	126 Mono On (Poly Off)
36 Foot Control LSB	82 Gen Purpose 7	127 Poly On (Mono Off)
37 Porta Time LSB	83 Gen Purpose 8	Extra RPN Messages
38 Data Entry LSB	84 Portamento Control	128 Pitch Bend Sensitivity
39 Channel Volume LSB	85 Controller 85	129 Fine Tune
40 Balance LSB	86 Controller 86	130 Coarse Tune
41 Controller 41	87 Controller 87	131 Channel Pressure
42 Pan LSB	88 Controller 88	
43 Expression LSB	89 Controller 89	
44 Controller 44	90 Controller 90	
45 Controller 45	91 Reverb Depth	

Appendix B: Assignable MIDI CC's**Sliders and Knobs:**

MIDI CC	Description	Data 2	Data 3
0-119	Standard MIDI CC's (<i>Appendix A</i>)	Min	Max
120-127	Channel Mode Messages (<i>Appendix A</i>)	Min	Max
128	Pitch Bend Sensitivity	Min	Max
129	Channel Fine Tune	Min	Max
130	Channel Coarse Tune	Min	Max
131	Channel Pressure	Min	Max
132	RPN coarse	RPN LSB	RPN LSB
133	RPN Fine	RPN LSB	RPN LSB
134	NRPN Coarse	NRPN LSB	NRPN LSB
135	NRPN Fine	NRPN LSB	NRPN LSB
136	Master Volume GM*	Min	Max
137	Master Pan GM*	Min	Max
138	Master Coarse Tune GM*	Min	Max
139	Master Fine Tune GM*	Min	Max
140	Chorus Mod rate GM2*	Min	Max
141	Chorus Mod Depth GM2*	Min	Max
142	Feedback GM2*	Min	Max
143	Send to Reverb GM2*	Min	Max
144	Pitch Bend	-	-
255	Controller Off**	-	-

*General MIDI SysEx messages

**Press "0," and then press the Enter key. Next press the Data - button

Buttons and Pedal:

MIDI CC	Description	Data 1	Data 2	Data 3
0-119	Standard MIDI CC's (<i>Appendix A</i>)	-	Toggle Value 2	Toggle Value 1
120-127	Channel Mode Messages (<i>Appendix A</i>)	-	Toggle Value 2	Toggle Value 1
128	Pitch Bend Range	-	Sensitivity Value	-
129	Channel Fine Tune	-	Tuning Amount	-
130	Channel Coarse Tune	-	Tuning Amount	-
131	Channel Pressure	-	Pressure Amount	-
132	RPN coarse	Value	RPN LSB	RPN MSB
133	RPN Fine	Value	RPN LSB	RPN MSB
134	NRPN Coarse	Value	NRPN LSB	NRPN MSB
135	NRPN Fine	Value	NRPN LSB	NRPN MSB
136	Master Volume GM*	-	Volume LSB	Volume MSB
137	Master Pan GM*	-	Pan LSB	Pan MSB
138	Master Coarse Tune GM*	-	Tuning LSB	Tuning MSB
139	Master Fine Tune GM*	-	Tuning LSB	Tuning MSB
140	Chorus Mod rate GM2*	-	Mod Rate	-
141	Chorus Mod Depth GM2*	-	Mod Depth	-
142	Feedback GM2*	-	Feedback Level	-
143	Send to Reverb GM2*	-	Reverb Send Level	-
144	Pitch Bend	-	Pitch Shift LSB	Pitch Shift MSB
145	Program/Bank Preset	Program	Bank LSB	Bank MSB
146	MIDI CC (On/Off)	MIDI CC	Button Press Value	Button Release Value
147	Note (On/Off)	Note	Velocity Off	Velocity On
148	Note (On/Off Toggle)	Note	Velocity Off	Velocity On
149	MMC Command**	-	Command Select	-
150	Reverb Type GM2*	-	Type	-
151	Reverb Time GM2*	-	Time	-
152	Chorus Type GM2*	-	Type	-
153	MIDI CC decrement	MIDI CC	Min	Max
154	MIDI CC increment	MIDI CC	Min	Max
155	Program decrement	-	Min	Max
156	Program increment	-	Min	Max
255	Controller Off**	-	-	-

*General MIDI SysEx messages

**Press "0," and then press the Enter key. Next press the Data - button

Appendix C - Useful MIDI Data

Piano	Bass	Reed	Synth Effects
0 Acoustic Grand Piano 1 Bright Acoustic Piano 2 Electric grand Piano 3 Honky Tonk Piano 4 Electric Piano 1 5 Electric Piano 2 6 Harpsichord 7 Clavinet	32 Acoustic Bass 33 Fingered Bass 34 Electric Picked Bass 35 Fretless Bass 36 Slap Bass 1 37 Slap Bass 2 38 Syn Bass 1 39 Syn Bass 2	64 Soprano Sax 65 Alto Sax 66 Tenor Sax 67 Baritone Sax 68 Oboe 69 English Horn 70 Bassoon 71 Clarinet	96 SFX Rain 97 SFX Soundtrack 98 SFX Crystal 99 SFX Atmosphere 100 SFX Brightness 101 SFX Goblins 102 SFX Echoes 103 SFX Sci-Fi
Chromatic Percussion	Strings/Orchestra	Pipe	Ethnic
8 Celesta 9 Glockenspiel 10 Music Box 11 Vibraphone 12 Marimba 13 Xylophone 14 Tubular bells 15 Dulcimer	40 Violin 41 Viola 42 Cello 43 Contrabass 44 Tremolo Strings 45 Pizzicato Strings 46 Orchestral Harp 47 Timpani	72 Piccolo 73 Flute 74 Recorder 75 Pan Flute 76 Bottle Blow 77 Shakuhachi 78 Whistle 79 Ocarina	104 Sitar 105 Banjo 106 Shamisen 107 Koto 108 Kalimba 109 Bag Pipe 110 Fiddle 111 Shanai
Organ	Ensemble	Synth Lead	Percussive
16 Drawbar Organ 17 Percussive Organ 18 Rock Organ 19 Church Organ 20 Reed Organ 21 Accordion 22 Harmonica 23 Tango Accordion	48 String Ensemble 1 49 String Ensemble 2 50 Syn Strings 1 51 Syn Strings 2 52 Choir Aahs 53 Voice Oohs 54 Syn Choir 55 Orchestral Hit	80 Syn Square Wave 81 Syn Sawtooth Wave 82 Syn Calliope 83 Syn Chiff 84 Syn Charang 85 Syn Voice 86 Syn Sawtooth Wave 87 Syn Brass & Lead	112 Tinkle Bell 113 Agogo 114 Steel Drums 115 Woodblock 116 Taiko Drum 117 Melodic Tom 118 Syn Drum 119 Reverse Cymbal
Guitar	Brass	Synth Pad	Sound Effects
24 Nylon Acoustic 25 Steel Acoustic 26 Jazz Electric 27 Clean Electric 28 Muted Electric 29 Overdrive 30 Distorted 31 Harmonics	56 Trumpet 57 Trombone 58 Tuba 59 Muted Trumpet 60 French Horn 61 Brass Section 61 Syn Brass 1 62 Syn Brass 2	88 New Age Syn Pad 89 Warm Syn Pad 90 Polysynth Syn Pad 91 Choir Syn Pad 92 Bowed Syn Pad 93 Metal Syn Pad 94 Halo Syn Pad 95 Sweep Syn Pad	120 Guitar Fret Noise 121 Breath Noise 122 Seashore 123 Bird Tweet 124 Telephone Ring 125 Helicopter 126 Applause 127 Gun Shot

NOTE: Some MIDI devices count preset sounds from 1-128 instead of 0-127. As a result, there may be an offset of +/-1 between the program change number sent from the keyboard and the recalled sound preset on your module.

MIDI Note Numbers

Octave (n)	Note Numbers											
	Cn	C#n	Dn	D#n	En	Fn	F#n	Gn	G#	A	A#n	Bn
-1	0	1	2	3	4	5	6	7	8	9	10	11
0	12	13	14	15	16	17	18	19	20	21	22	23
1	24	25	26	27	28	29	30	31	32	33	34	35
2	36	37	38	39	40	41	42	43	44	45	46	47
3	48	49	50	51	52	53	54	55	56	57	58	59
4	60	61	62	63	64	65	66	67	68	69	70	71
5	72	73	74	75	76	77	78	79	80	81	82	83
6	84	85	86	87	88	89	90	91	92	93	94	95
7	96	97	98	99	100	101	102	103	104	105	106	107
8	108	109	110	111	112	113	114	115	116	117	118	119
9	120	121	122	123	124	125	126	127				

Appendix D - DirectLink Transport Control Assignments

Pro Tools 8 users can access additional functions via the Loop button:

1. Holding the Loop button while pressing one of the other Transport Control buttons gives access to additional Pro Tools transport functions.

Button	Pro Tools Control	Modified Button	Pro Tools Control
LOOP*	-	-	-
REW	REW	LOOP + REW	Goto Start
FWD	FWD	LOOP + FWD	Goto End
STOP	STOP	LOOP + STOP	Undo
PLAY	PLAY	LOOP + PLAY	Loop Play Mode
REC	REC	LOOP + REC	Loop Record Mode

2. Quickly pressing the Loop button toggles the control knobs on your Oxygen keyboard between Instrument Mode and Mixer mode.

- Mixer mode (default); The 8 knobs control their corresponding tracks' pan or balance settings.
- Instrument Mode: The 8 control knobs automatically map to 8 parameters on the active Instrument or Effect Plug-In. The Instrument mode parameter mapping can be customized by clicking the "learn" button in the upper right corner of the Plug-In. Please check the Pro Tools 8 documentation for more details.

Appendix E - Hexadecimal Conversion Chart**Hexadecimal to Decimal Conversion Chart**

Hexadecimal Value	Decimal Value	Hexadecimal Value	Decimal Value	Hexadecimal Value	Decimal Value
0	0	2B	43	56	86
1	1	2C	44	57	87
2	2	2D	45	58	88
3	3	2E	46	59	89
4	4	2F	47	5A	90
5	5	30	48	5B	91
6	6	31	49	5C	92
7	7	32	50	5D	93
8	8	33	51	5E	94
9	9	34	52	5F	95
0A	10	35	53	60	96
0B	11	36	54	61	97
0C	12	37	55	62	98
0D	13	38	56	63	99
0E	14	39	57	64	100
0F	15	3A	58	65	101
10	16	3B	59	66	102
11	17	3C	60	67	103
12	18	3D	61	68	104
13	19	3E	62	69	105
14	20	3F	63	6A	106
15	21	40	64	6B	107
16	22	41	65	6C	108
17	23	42	66	6D	109
18	24	43	67	6E	110
19	25	44	68	6F	111
1A	26	45	69	70	112
1B	27	46	70	71	113
1C	28	47	71	72	114
1D	29	48	72	73	115
1E	30	49	73	74	116
1F	31	4A	74	75	117
20	32	4B	75	76	118
21	33	4C	76	77	119
22	34	4D	77	78	120
23	35	4E	78	79	121
24	36	4F	79	7A	122
25	37	50	80	7B	123
26	38	51	81	7C	124
27	39	52	82	7D	125
28	40	53	83	7E	126
29	41	54	84	7F	127
2A	42	55	85		

Appendix F - Roland GS & Yamaha XG NRPN Messages

NRPN	NRPN	Data	Data
MSB	LSB	MSB	LSB
CC99	CC98	CC06	CC38
01	08	00-7F	n/a (-64 - 0 - +63) Vibrato Rate (relative change)
01	09	00-7F	n/a (-64 - 0 - +63) Vibrato Depth (relative change)
01	0A	00-7F	n/a (-64 - 0 - +63) Vibrato Delay (relative change)
01	20	00-7F	n/a (-64 - 0 - +63) Filter Cutoff Freq. (relative change)
01	21	00-7F	n/a (-64 - 0 - +63) Filter Resonance (relative change)
01	63	00-7F	n/a (-64 - 0 - +63) EG (TVF&TVA) Attack Time (relative change)
01	64	00-7F	n/a (-64 - 0 - +63) EG (TVF&TVA) Decay Time (relative change)
01	66	00-7F	n/a (-64 - 0 - +63) EG (TVF&TVA) Release Time (relative change)
14	00-7F	00-7F	n/a (-64 - 0 - +63) Drum Filter Cutoff Freq. (relative change)*
15	00-7F	00-7F	n/a (-64 - 0 - +63) Drum Filter Resonance (relative change)*
16	00-7F	00-7F	n/a (-64 - 0 - +63) Drum EG Attack Rate (relative change)*
17	00-7F	00-7F	n/a (-64 - 0 - +63) Drum EG Decay Rate (relative change)*
18	00-7F	00-7F	n/a (-64 - 0 - +63) Drum Instrument Pitch Coarse (relative change)
19	00-7F	00-7F	n/a (-64 - 0 - +63) Drum Instrument Pitch Fine (relative change)*
1A	00-7F	00-7F	n/a (0 to Max) Drum Instrument Level (absolute change)
1C	00-7F	00-7F	n/a (Random, L>C>R) Drum Instrument Pan pot (absolute change)
1D	00-7F	00-7F	n/a (0 to Max) Drum Instrument Reverb Send Level (absolute change)
1E	00-7F	00-7F	n/a (0 to Max) Drum Instrument Chorus Send Level (absolute change)
1F	00-7F	00-7F	n/a (0 to Max) Drum Instrument Variation Send Level (absolute change)**

*added by Yamaha XG;

**changed from Delay to Variation by Yamaha XG

Appendix G - General MIDI Reverb and Chorus Types

Reverb Types

- 0: Small Room
- 1: Medium Room
- 2: Large Room
- 3: Medium Hall
- 4: Large Hall
- 5: Plate

Chorus Types

- 0: Chorus 1
- 1: Chorus 2
- 2: Chorus 3
- 3: Chorus 4
- 4: FB Chorus
- 5: Flanger

M-AUDIO
a part of **Avid**

www.m-audio.com

M-AUDIO
5795 Martin Road
Irwindale, CA 91706, USA

TECHNICAL SUPPORT
Visit the M-Audio Online Support Center
at www.m-audio.com/support

PRODUCT INFORMATION
For company and product information
visit us on the web at www.m-audio.com