

# **NordicTrack**<sup>®</sup> CX 995

Model No. NTE13921

Serial No. \_\_\_\_\_

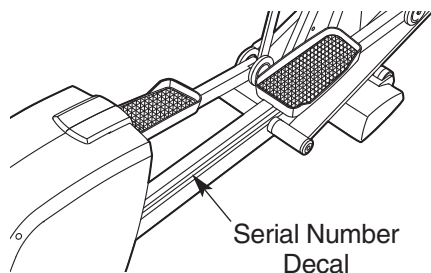

## USER'S MANUAL

### QUESTIONS?

If you have questions, or if there are missing parts, we will guarantee complete satisfaction through direct assistance from our factory.

TO AVOID DELAYS, PLEASE CALL DIRECT TO OUR TOLL-FREE CUSTOMER HOT LINE. The trained technicians on our customer hot line will provide immediate assistance, free of charge to you.

CUSTOMER HOT LINE:

**1-888-825-2588**

Mon.-Fri., 6 a.m.-6 p.m. MST

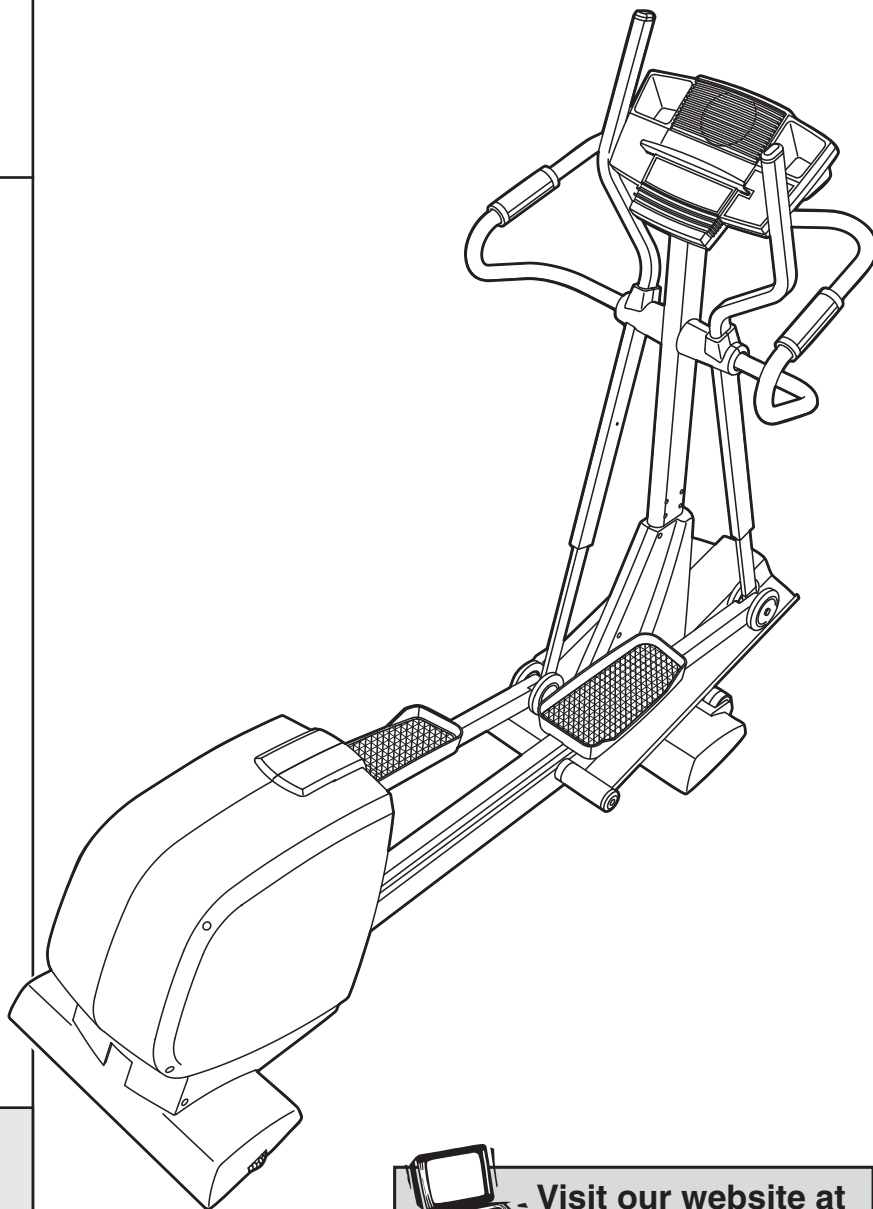

### CAUTION

Read all precautions and instructions in this manual before using this equipment. Keep this manual for future reference.



Visit our website at

[www.nordictrack.com](http://www.nordictrack.com)

*new products, prizes,  
fitness tips, and much more!*



# NordicTrack<sup>®</sup>

## CX 995

---

## TABLE OF CONTENTS

IMPORTANT PRECAUTIONS .....	.3
BEFORE YOU BEGIN .....	.4
ASSEMBLY .....	.5
HOW TO USE THE CHEST PULSE SENSOR .....	.9
HOW TO USE THE ELLIPTICAL EXERCISER .....	.11
MAINTENANCE AND TROUBLESHOOTING .....	.26
CONDITIONING GUIDELINES .....	.27
PART LIST .....	.28
EXPLODED DRAWING .....	.30
HOW TO ORDER REPLACEMENT PARTS .....	.Back Cover
LIMITED WARRANTY .....	.Back Cover

# IMPORTANT PRECAUTIONS

**⚠ WARNING:** To reduce the risk of serious injury, read the following important precautions before using the elliptical exerciser.

1. Read all instructions in this manual before using the elliptical exerciser.
2. It is the responsibility of the owner to ensure that all users of the elliptical exerciser are adequately informed of all precautions.
3. The elliptical exerciser is intended for in-home use only. Do not use the elliptical exerciser in a commercial, rental, or institutional setting.
4. Place the elliptical exerciser on a level surface, with a mat beneath it to protect the floor or carpet. Keep the elliptical exerciser indoors, away from moisture and dust.
5. Inspect and properly tighten all parts regularly. Replace any worn parts immediately.
6. Keep children under age 12 and pets away from the elliptical exerciser at all times.
7. The elliptical exerciser should not be used by persons weighing more than 250 pounds.
8. Wear appropriate exercise clothing when using the elliptical exerciser. Always wear athletic shoes for foot protection.
9. Always hold the handlebars when mounting, dismounting, or using the elliptical exerciser.
10. Keep your back straight when using the elliptical exerciser; do not arch your back.
11. If you feel pain or dizziness while exercising, stop immediately and cool down.
12. The pulse sensors are not medical devices. Various factors, including the user's movement, may affect the accuracy of heart rate readings. The pulse sensors are intended only as exercise aids in determining heart rate trends in general.
13. When you stop exercising, allow the pedals to slowly come to a complete stop. The elliptical exerciser does not have a free wheel; the pedals will continue to move until the flywheel stops.
14. Always unplug the power cord immediately after use and before cleaning the elliptical exerciser.
15. The decal shown below has been placed on the elliptical exerciser. If the decal is missing or illegible, please call our Customer Service Department toll-free at 1-888-825-2588 to order a free replacement decal. Apply the decal in the location shown.

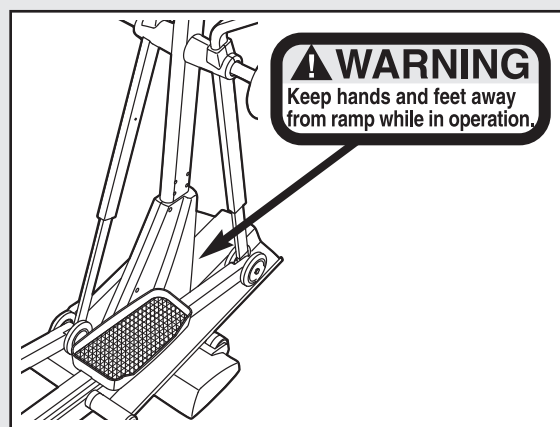

**⚠ WARNING:** Before beginning this or any exercise program, consult your physician. This is especially important for persons over the age of 35 or persons with pre-existing health problems. Read all instructions before using. ICON assumes no responsibility for personal injury or property damage sustained by or through the use of this product.

# BEFORE YOU BEGIN

Congratulations for selecting the new NordicTrack® CX 995 elliptical exerciser. The CX 995 is an incredibly smooth exerciser that moves your feet in a natural elliptical path, minimizing the impact on your knees and ankles. And the unique CX 995 features adjustable resistance and incline to help you get the most from your exercise. Welcome to a whole new world of natural, elliptical-motion exercise from NordicTrack.



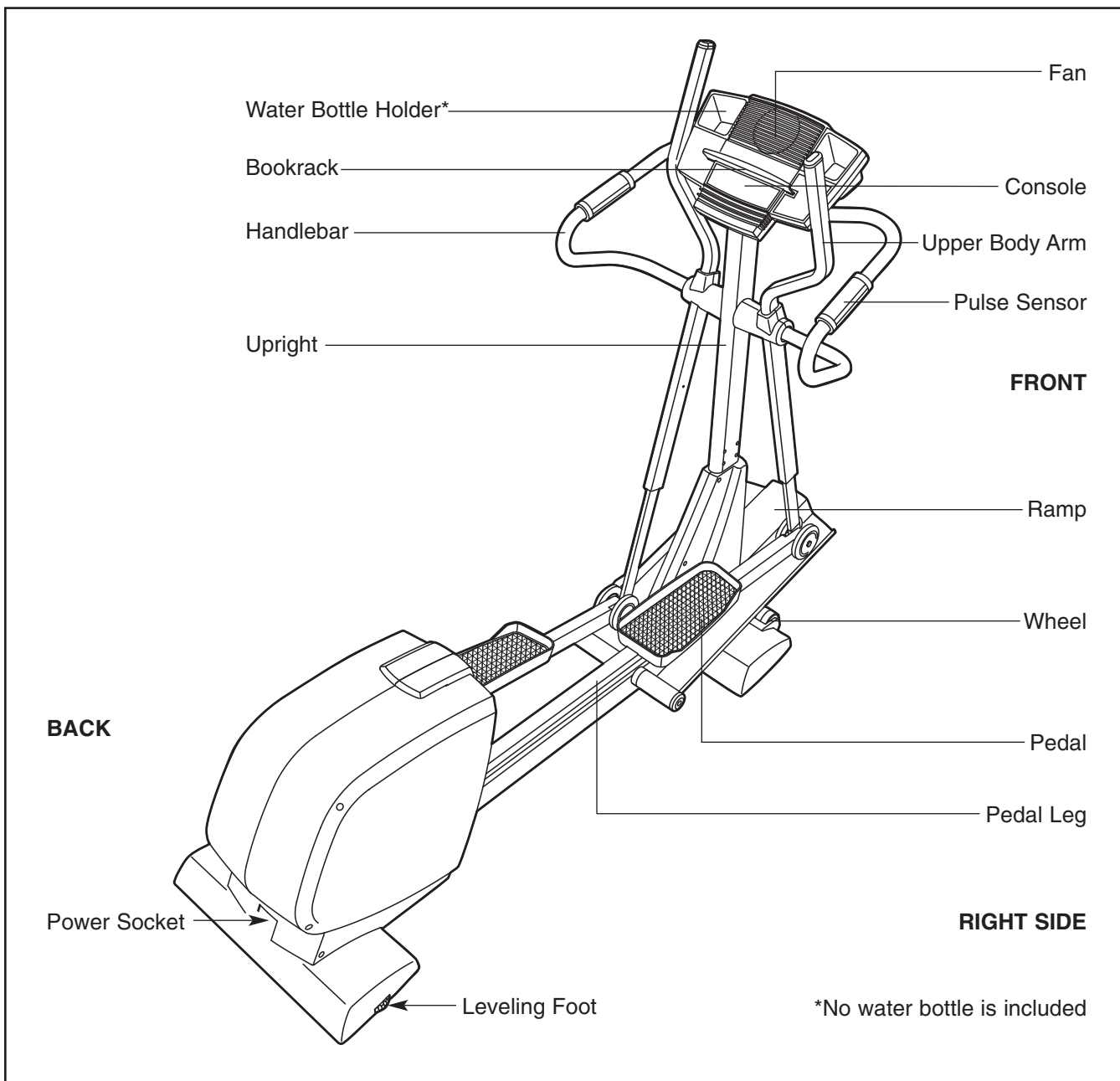

For additional questions, please call our Customer Service Department toll-free at 1-888-825-2588, Monday through Friday, 6 a.m. until 6 p.m. Mountain Time (excluding holidays). To help us assist you, please note the product model number and serial number before calling. The model number is NTE13921. The serial number can be found on a decal attached to the elliptical exerciser (see the front cover of this manual for the location of the decal).

**For your benefit, read this manual carefully before you use the elliptical exerciser.** If you have addi-

Before reading further, please familiarize yourself with the parts that are labeled in the drawing below.



# ASSEMBLY

**Assembly requires two persons.** Place all parts of the elliptical exerciser in a cleared area and remove the packing materials. Do not dispose of the packing materials until assembly is completed. **In addition to the included allen wrenches, assembly requires a phillips screwdriver** , **two adjustable wrenches** , **a rubber mallet** , and **pliers** .

As you assemble the elliptical exerciser, use the drawings below to identify the small parts used in assembly. The number in parenthesis below each drawing refers to the key number of the part, from the PART LIST on pages 28 and 29. The second number refers to the quantity used in assembly. **Note: Some small parts may have been pre-assembled. If a part is not in the parts bag, check to see if it is pre-assembled.**

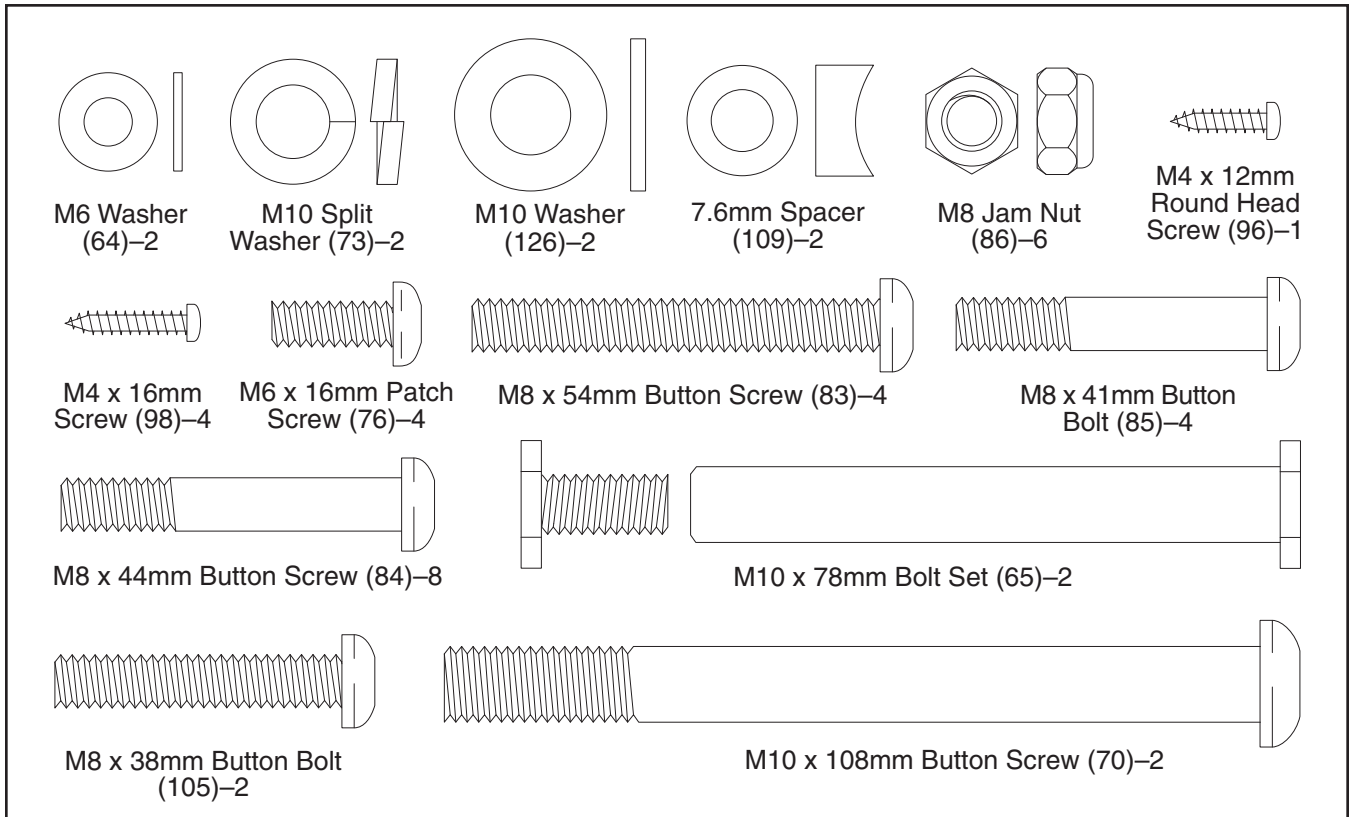

1. Identify the Front Stabilizer (8). While another person lifts the front of the Frame (1) and holds the Pedal Legs (4, 5) in the position shown, attach the Front Stabilizer to the Frame with four M8 x 44mm Button Screws (84) and a Support Plate (104).

**While another person lifts the rear of the Frame (1), attach the Rear Stabilizer (not shown) to the Frame in the same way.**

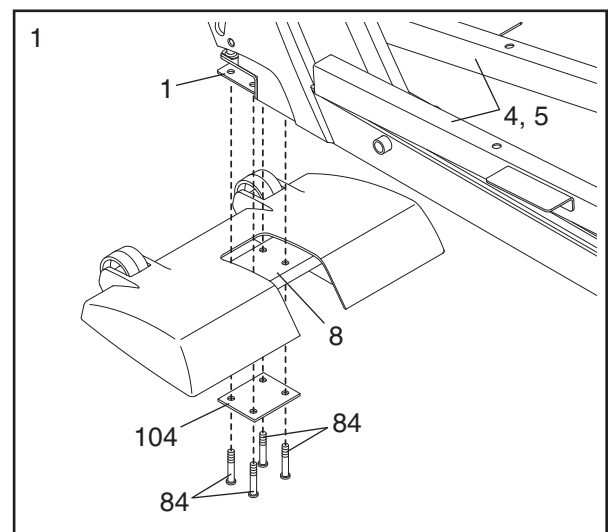

- Identify the Pivot Axle (14), which is the **longer** of the two axles. Slide a Ramp Cover (48) onto an M6 x 16mm Patch Screw (76) as shown. Tighten the Patch Screw into one end of the Pivot Axle. Apply a small amount of the included grease to the Pivot Axle.

Have a second person hold the two Ramp Spacers (99) against the sides of the Frame (1) so that they cover the indicated tubes on the Frame. Align the round tubes on the Ramp (3) with the Ramp Spacers. **Make sure that the Ramp is turned as shown in drawing 3 below.** Insert the Pivot Axle (14) into the Ramp, the Ramp Spacers, and the Frame. If necessary, tap the Pivot Axle with a rubber mallet to insert it.

Slide the other Ramp Cover (48) onto an M6 x 16mm Patch Screw (76) as shown. Tighten the Patch Screw into the open end of the Pivot Axle (14).

- Slide an M6 Washer (64) onto an M6 x 16mm Patch Screw (76). Tighten the Patch Screw into one end of the Incline Axle (13). Apply a small amount of grease to the Incline Axle.

Raise the Ramp (3). Insert the Incline Axle (13) into the welded tube under one side of the Ramp, through the motor screw, and then into the welded tube under the other side of the Ramp. **As you insert the Incline Axle through the motor screw, make sure that the motor screw does not turn.**

Slide an M6 Washer (64) onto an M6 x 16mm Patch Screw (76). Tighten the Patch Screw into the open end of the Incline Axle (13).

- Have another person hold the Upright (2) in the position shown.

Connect the Upper Wire Harness (115) to the Lower Wire Harness (42). Insert the connectors on the Wire Harnesses up into the Upright (2). **Carefully pull the upper end of the Upper Wire Harness to remove the slack from the Wire Harnesses.** See the inset drawing. Attach the Lower Wire Harness to the Upright with the Nylon Zip Tie (127). Pull the Nylon Zip Tie tight and cut off the excess.

Insert the Upright (2) into the Frame (1). **Be careful to avoid pinching the Wire Harnesses (115, 42).** Attach the Upright with two M10 x 108mm Button Screws (70), two M10 Split Washers (73), and two 7.6mm Spacers (109); **make sure that the curved sides of the Spacers are facing the Upright.** **Be careful to avoid damaging the Wire Harnesses with the Button Screws.**

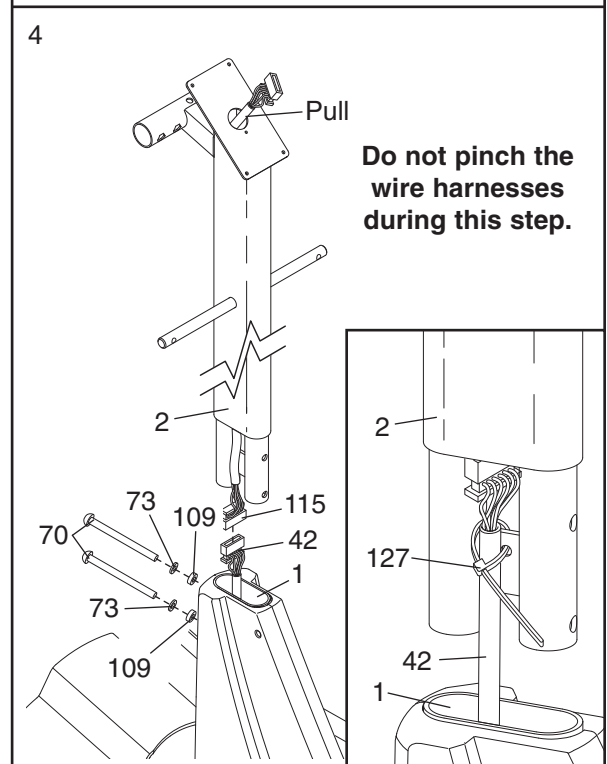
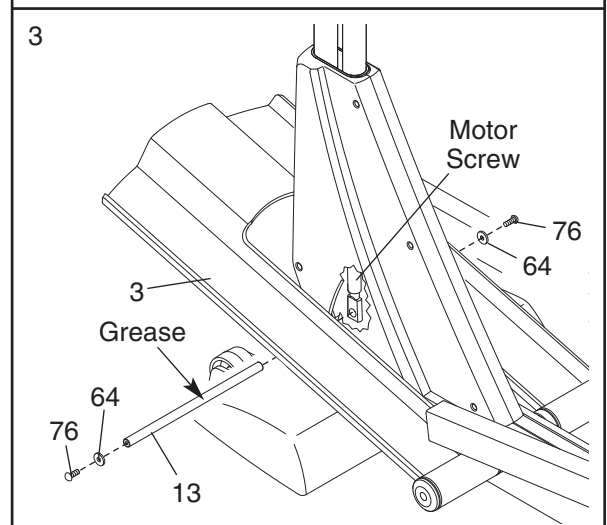
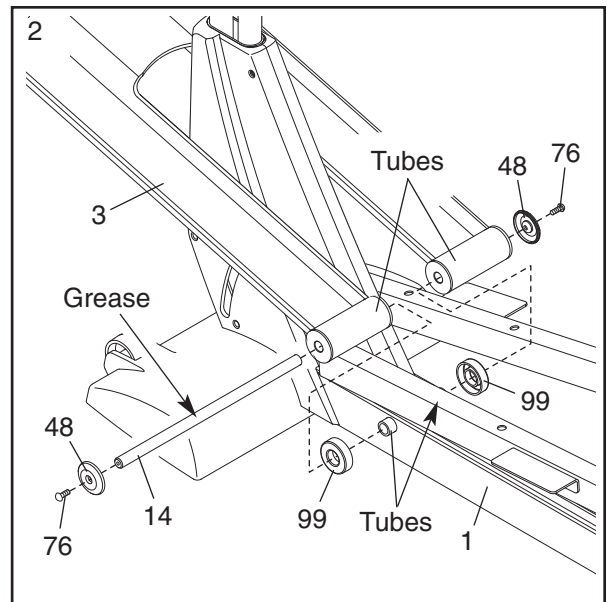

- Slide a Weld Spacer (119) onto the axle on the left side of the Upright (2), with the open side of the Weld Spacer facing the Upright.

Locate the Upper Body Arm (118) that has the Left Upper Body Leg (31) inside of it (the Left Upper Body Leg is marked with a sticker). Hold the Upper Body Arm with one hand, hold the Left Upper Body Leg with your other hand, and slide the Upper Body Arm onto the axle on the left side of the Upright (2). Then, slide the Left Upper Body Leg out of the Upper Body Arm until it rests on the Ramp (3).

Have another person hold the Left Handlebar (24) near the Upright (2) as shown. Connect the left Pulse Sensor Wire (20) to the Pulse Extension Wire (114).

Slide the upper end of the Left Handlebar (24) into the tube on the front of the Upright (2), while sliding the lower end of the Left Handlebar onto the axle on the left side of the Upright. Attach the upper end of the Left Handlebar with two M8 x 41mm Button Bolts (85) and two M8 Jam Nuts (86); **be careful not to damage the Wires (20, 114) as you insert the Button Bolts. Make sure that the Jam Nuts are resting in the hexagonal holes in the Left Handlebar.** Attach the lower end of the Left Handlebar with an M8 x 38mm Button Bolt (105) and an M8 Jam Nut (86).

Attach the other Upper Body Arm (118) and the Right Handlebar (23) to the Upright (2) in the same way.

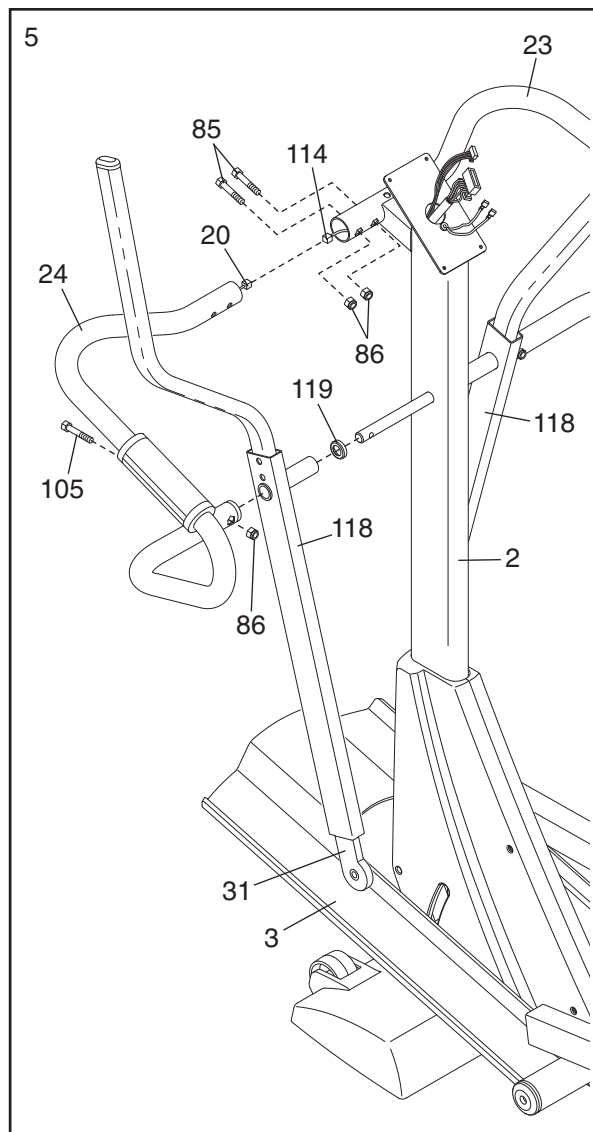

- Look inside one of the Handlebar Covers (26) and locate the square tabs connecting the two halves. Gently lift the tabs and disconnect the halves.

Hold the two halves of the Handlebar Cover (26) around the tube on the left side of the Upright (2). Align the halves and press them together until they lock.

Attach the other Handlebar Cover (26) to the right side of the Upright (2) in the same way.

Hold the halves of the Upper Handlebar Cover (25) around the tube on the front of the Upright (2); **be careful not to damage the Wires (not shown).** Attach the Upper Handlebar Cover with an M4 x 12mm Round Head Screw (96).

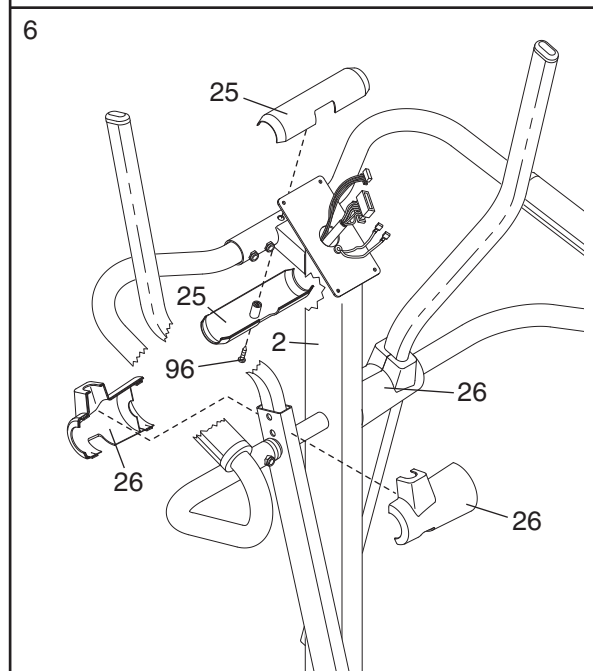

7. Identify the Left Pedal (10), which is widest at the rear and has an opening on the left side. Attach the Left Pedal to the Left Pedal Leg (4) with two M8 x 54mm Button Screws (83).

Attach the Right Pedal (11) to the Right Pedal Leg (5) in the same way.

Attach two Pedal Wheels (28), an M10 Washer (126), and the Left Upper Body Leg (31) to the Wheel Frame (30) on the Left Pedal Leg (4) with an M10 x 78mm Bolt Set (65). **Make sure that the Bolt Set, Pedal Wheels, Washer, and Upper Body Leg are oriented as shown.**

Attach the other two Pedal Wheels, the Right Upper Body Leg, and an M10 Washer (not shown) to the Wheel Frame (not shown) on the Right Pedal Leg (5) in the same way.

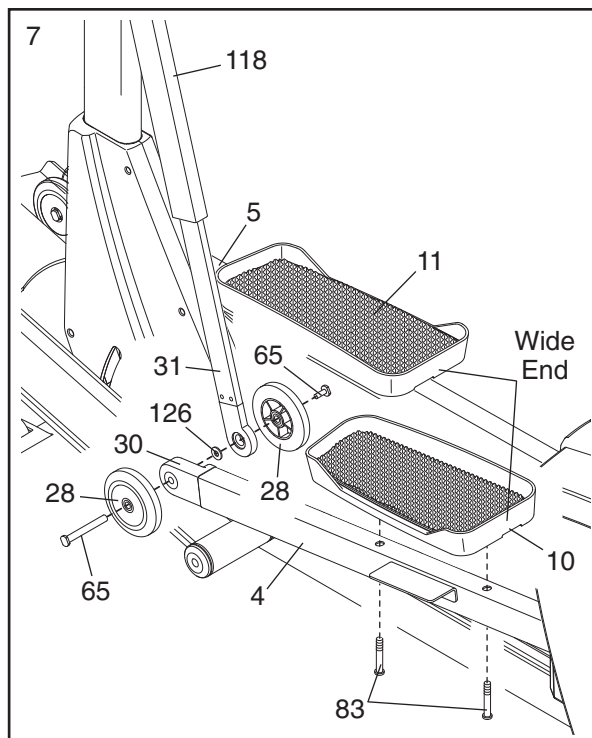

8. Have another person hold the Console (17) near the Upright (2).

Connect the Upper Wire Harness (115) to the wire harness on the Console (17). Connect the Pulse Extension Wire (114) to the pulse wire on the Console. Next, locate the two ground wires that are attached with a screw to the Upright (2). Connect the ground wires to the two smallest wires on the Console.

Carefully insert all excess wiring up into the Console (17) and down into the Upright (2). Attach the Console to the Upright with four M4 x 16mm Screws (98). (Note: The Screws may be shipped in the console box.) **Be careful to avoid pinching the wires.**

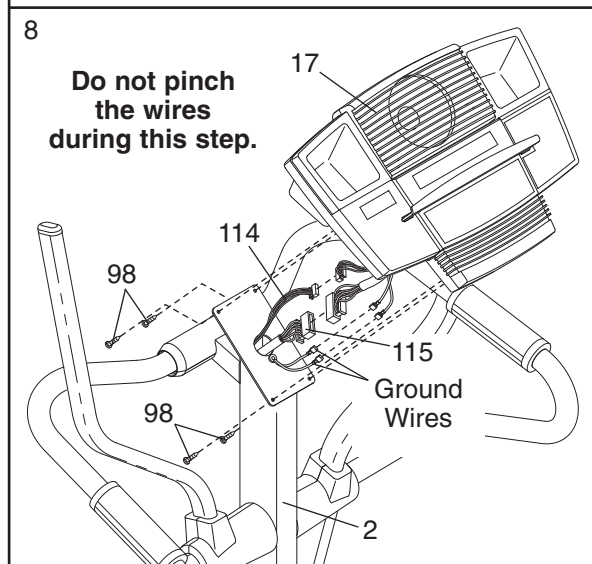

9. Plug the Power Cord (116) into the Power Socket (117) at the rear of the elliptical exerciser.

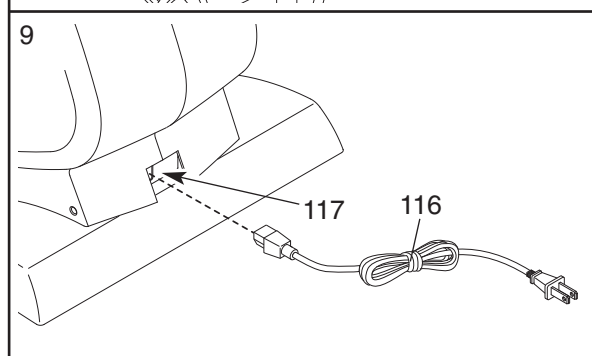

10. **Make sure that all parts of the elliptical exerciser are properly tightened.** Cover the floor beneath the elliptical exerciser to protect the floor from damage. Note: Some extra hardware may be left over.



# HOW TO USE THE CHEST PULSE SENSOR

To get the best performance from the chest pulse sensor, please read the instructions below.

## HOW TO PUT ON THE CHEST PULSE SENSOR

The chest pulse sensor consists of two components: the chest strap and the sensor unit. Follow the steps below to put on the chest pulse sensor.

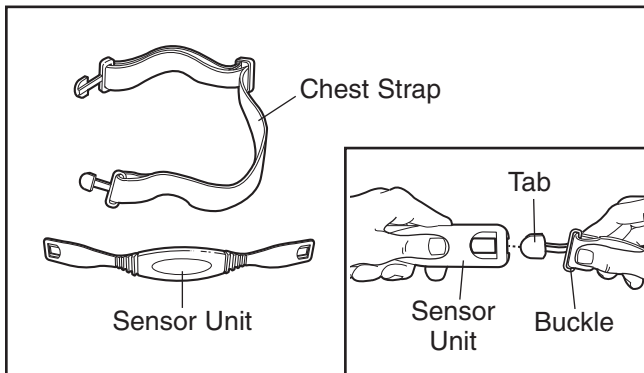

**1** Refer to the inset drawing above. Insert the tab on one end of the chest strap through one end of the sensor unit as shown. Then, press the end of the sensor unit under the buckle on the chest strap.

**2** Wrap the chest pulse sensor around your chest. Attach the free end of the chest

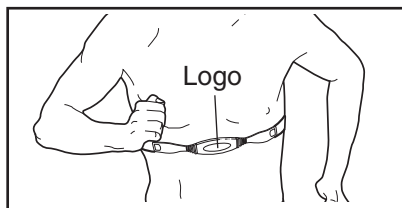

strap to the sensor unit as described above. Adjust the length of the chest strap, if necessary. The chest pulse sensor should be under your clothing, against your skin, and as high under the pectoral muscles or breasts as is comfortable. Make sure that the logo is facing forward and is right-side-up.

**3** Pull the sensor unit away from your body a few inches and locate the

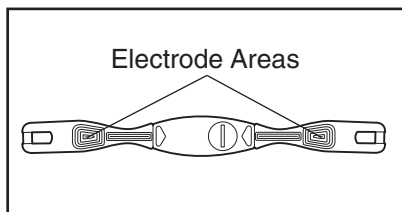

two electrode areas on the inner side. Using a saline solution such as saliva or contact lens solution, wet both electrode areas. Return the sensor unit to a position against your chest.

## CHEST PULSE SENSOR TROUBLESHOOTING

**If the chest pulse sensor does not function properly, or if the displayed heart rate is excessively high or low, try the steps below.**

- Make sure that the chest pulse sensor is worn exactly as described in step 2 at the left. If the chest pulse sensor does not function when positioned as described, move it slightly lower or higher on your chest.
- Each time you use the chest pulse sensor, use saline solution such as saliva or contact lens solution to wet the two electrode areas on the sensor unit (see the drawing in step 3 at the left). If heart rate readings do not appear until you begin perspiring, re-wet the electrode areas.
- Make sure that you are within arm's length of the console. **For the console to display heart rate readings, the user must be within arm's length of the console.**
- The chest pulse sensor is designed to work with people who have normal heart rhythms. Heart rate reading problems may be caused by medical conditions such as premature ventricular contractions (pvc's), tachycardia bursts, and arrhythmia.
- The operation of the chest pulse sensor can be affected by magnetic interference caused by high power lines or other sources. If it is suspected that magnetic interference may be causing a problem, try relocating your exercise equipment.
- If the chest pulse sensor still does not function properly, test the chest pulse sensor in the following way:

Hold the chest pulse sensor and place your thumbs over the electrode areas as shown.

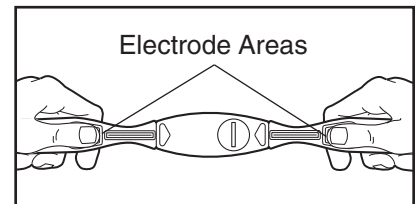

Next, hold the chest pulse sensor near the console. While holding one thumb stationary, begin tapping the other thumb against the electrode area at a rate of about one tap per second. Check the heart rate reading on the console.

- If the chest pulse sensor does not function properly after you have followed all of the above instructions, the battery should be replaced in the following way:

Locate the battery cover on the back of the sensor unit. Insert a coin into the slot in the cover, turn the cover counterclockwise, and remove the cover.

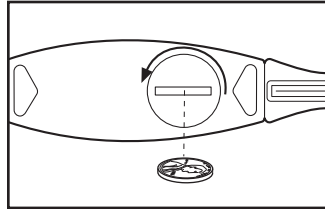

Remove the old battery and insert a new CR 2032 battery. **Make sure that the battery is turned so the writing is on top.** Replace the battery cover and turn it clockwise to close it.

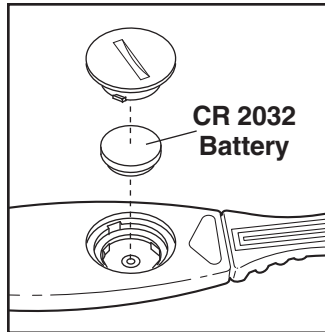

## CHEST PULSE SENSOR CARE

- Thoroughly dry the chest pulse sensor after each use. The chest pulse sensor is activated when the electrode areas are wetted and the chest pulse sensor is put on; the chest pulse sensor shuts off when it is removed and the electrode areas are dried. If the chest pulse sensor is not dried after each use, it may remain activated longer than necessary, draining the battery prematurely.
- Store the chest pulse sensor in a warm, dry place. Do not store the chest pulse sensor in a plastic bag or other container that may trap moisture.
- Do not expose the chest pulse sensor to direct sunlight for extended periods of time. Do not expose the chest pulse sensor to temperatures above 122° Fahrenheit (50° Celsius) or below 14° Fahrenheit (-10° Celsius).
- Do not excessively bend or stretch the sensor unit when using or storing the chest pulse sensor.
- Clean the sensor unit using a damp cloth—never use alcohol, abrasives, or chemicals. The chest strap may be hand washed and air dried.

# HOW TO USE THE ELLIPTICAL EXERCISER

## HOW TO PLUG IN THE POWER CORD

**This product must be grounded.** If it should malfunction or break down, grounding provides a path of least resistance for electric

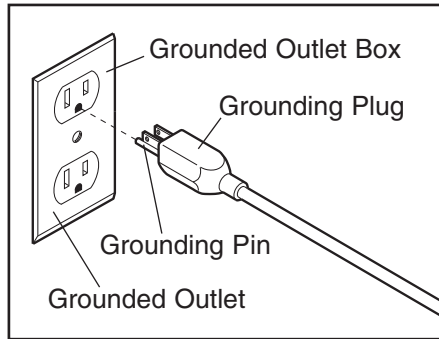

current to reduce the risk of electric shock. This product is equipped with a cord having an equipment-grounding conductor and a grounding plug. **Plug the power cord into an appropriate outlet that is properly installed and grounded in accordance with all local codes and ordinances. This product is for use on a nominal 120-volt circuit. Important: The elliptical exerciser is not compatible with GFCI-equipped outlets.**

**⚠ DANGER:** Improper connection of the equipment-grounding conductor can result in an increased risk of electric shock. Check with a qualified electrician or serviceman if you are in doubt as to whether the product is properly grounded. Do not modify the plug provided with the product—if it will not fit the outlet, have a proper outlet installed by a qualified electrician.

A temporary adapter may be used to connect the power cord to a 2-pole receptacle as shown at the right if a properly grounded outlet is not

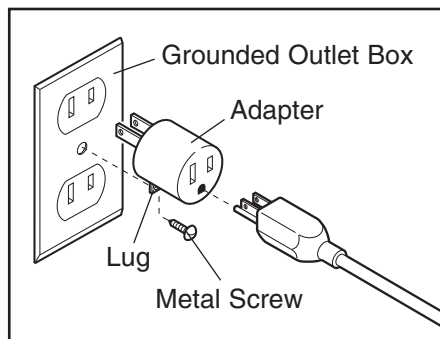

available. The temporary adapter should be used only until a properly grounded outlet can be installed by a qualified electrician.

The green-colored rigid ear, lug, or the like extending from the adapter must be connected to a permanent ground such as a properly grounded outlet box cover. Whenever the adapter is used, it must be held in place by a metal screw. **Some 2-pole receptacle outlet box covers are not grounded. Contact a qualified electrician to determine if the outlet box cover is grounded before using an adapter.**

**Note:** When the power cord is plugged in, the elliptical exerciser's incline system may automatically calibrate itself. During the calibration process, two dashes (--) will appear in the main display of the console, and the ramp will move to the highest position and then return to the lowest position. The calibration process will last for one to two minutes.

## EXERCISING ON THE ELLIPTICAL EXERCISER

To mount the elliptical exerciser, hold the handlebars and step onto the pedal that is in the lowest position. Next, step onto the other pedal. Push the pedals until they begin to move with a continuous motion.

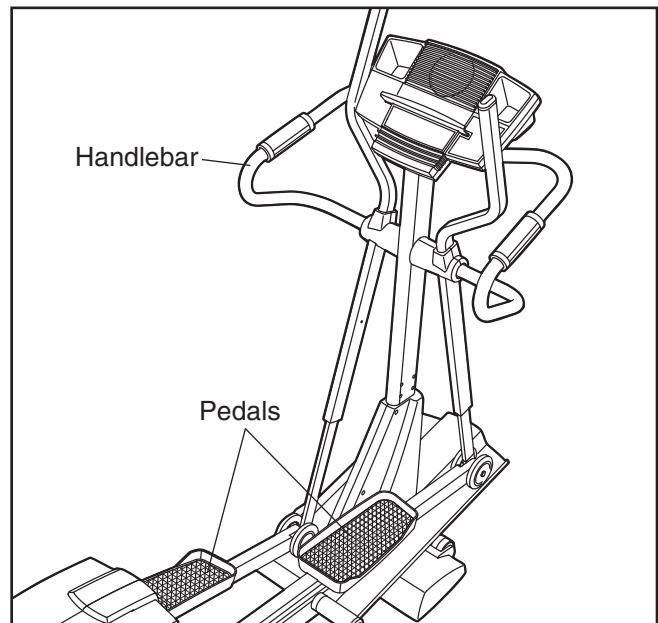

To dismount the elliptical exerciser, wait until the pedals come to a complete stop. **The elliptical exerciser does not have a free wheel; the pedals will continue to move until the flywheel stops.** When the pedals are stationary, step off the highest pedal first. Then, step off the lowest pedal.

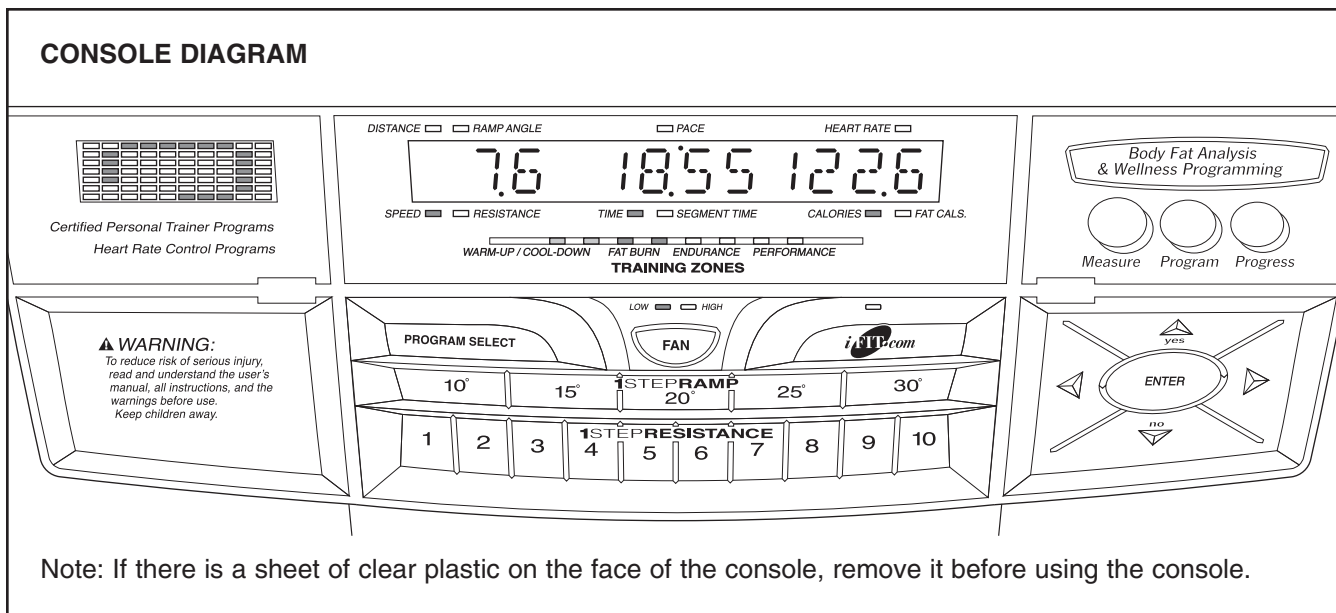

## FEATURES OF THE CONSOLE

The state-of-the-art console offers an impressive array of features. When the manual mode of the console is selected, the resistance of the pedals and the angle of the ramp can be changed with a touch of a button. As you exercise, the console will provide continuous exercise feedback. You can even measure your heart rate using the handgrip pulse sensor or the chest pulse sensor.

The console also offers 15 certified personal trainer programs. Each program automatically changes the resistance of the pedals and prompts you to increase or decrease your pace as it guides you through an effective workout.

In addition, the console features four heart rate control programs that automatically change the resistance of the pedals and prompt you to vary your pace to keep your heart rate near a target level as you exercise.

The console even measures your body fat percentage, provides custom programs based on personal data that you enter, and displays your fat burning or weight loss progress.

The console also features iFIT.com interactive technology. Having iFIT.com technology is like having a personal trainer in your home. Using the included audio cable, you can connect the elliptical exerciser to your home stereo, portable stereo, or computer and play

special iFIT.com CD programs (CDs are available separately). iFIT.com CD programs automatically control the resistance of the pedals and prompt you to vary your pace as a personal trainer coaches you through every step of your workout. High-energy music provides added motivation. Each CD features two programs designed by certified personal trainers.

In addition, you can connect the elliptical exerciser to your VCR and TV and play iFIT.com video programs (videocassettes are available separately). Video programs offer the same benefits as iFIT.com CD programs, and allow you to enjoy breathtaking scenery while you exercise. **To purchase iFIT.com CDs and videocassettes, call toll-free 1-800-735-0768.**

With the elliptical exerciser connected to your computer, you can also go to [www.iFIT.com](http://www.iFIT.com) and use programs directly from our Web site. Explore [www.iFIT.com](http://www.iFIT.com) for details.

**To use the manual mode of the console, see page 13. To use a personal trainer program, see page 15. To use a heart rate program, see page 16. To use an iFIT.com CD or videocassette, see page 21. To use a program from our Web site, see page 22.**

**To measure your body fat percentage, see page 23. To use a custom program based on personal data that you enter, see page 24. To review your fat burning or weight loss progress, see page 25.**

## HOW TO USE THE MANUAL MODE

### 1 Begin pedaling to activate the console.

Make sure that the power cord is properly plugged in (see **HOW TO PLUG IN THE POWER CORD** on page 11). To activate the console, simply begin pedaling. After a few seconds, the console displays will light. A tone will then sound and the console will be ready for use.

Note: When the console is activated, messages such as "PUSH 'MEASURE' TO DETERMINE YOUR BODY FAT PERCENTAGE" will scroll across the main display. If you wish to use these features, see pages 23 to 25.

### 2 Select the manual mode.

When the power is turned on, the manual mode will be selected. If you have already selected a program or a different mode, select the manual mode again by repeatedly pressing the Program Select button until the words "MANUAL MODE" appear in the main display. Another way to select the manual mode is to press the iFIT.com button twice.

### 3 Change the resistance of the pedals and the angle of the ramp as desired.

To change the resistance of the pedals, press the Resistance buttons. Resistance level 10 is the highest resistance level. Note: After the Resistance buttons are pressed, it will take a moment for the pedals to reach the selected resistance level.

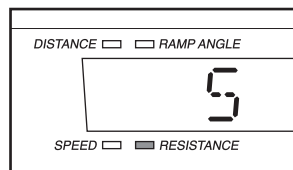

To vary the feel of your exercise on the elliptical exerciser, increase or decrease the angle of the ramp by pressing the Ramp buttons. There are five ramp angles. Note: After the Ramp buttons are pressed, it will take a moment for the ramp to reach the selected angle.

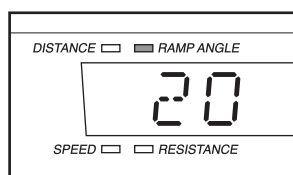

### 4 Monitor your progress with the matrix, the Training Zone bar, and the main display.

**The matrix**—When the manual mode or the iFIT.com mode is selected, the matrix will display a 1/4-mile track. As you pedal, the indicators around the track will light, one at a time, until the entire track is lit. The track will light once each time you pedal 1/4 mile.

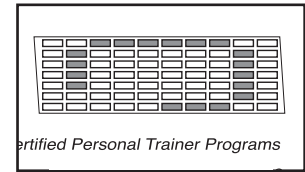

**The Training Zone bar**—The Training Zone bar will indicate the approximate intensity level of your exercise. For example, if three or four indicators in the bar are lit, the bar shows that your pace is ideal for fat burning. Note: During programs, the Training Zone bar will also prompt you to increase or decrease your pace.

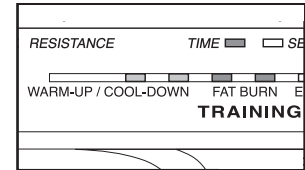

**The main display**—The main display will show the following information:

**The left side** of the main display will show the distance you have pedaled, your pedaling speed, the resistance level of the pedals, and the angle of the ramp. The display will change from one number to the next every few seconds, as shown by the indicators around the display.

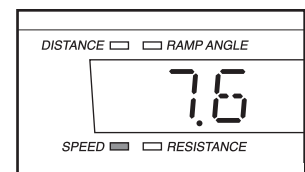

**The center** of the main display will show your pedaling pace (in *minutes per mile*) and the elapsed time. The display will change from one number to the next every few seconds, as shown by the indicators around the display. Note: When a program is selected, the display will show the time *remaining* in the program and the time remaining in the current segment of the program instead of the elapsed time.

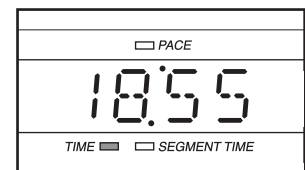

The right side of the main display will show the approximate numbers of calories and fat calories you have

burned (see FAT BURNING on page 27). The display will change from one number to the next every few seconds, as shown by the indicators around the display. Note: When you use the handgrip pulse sensor or the chest pulse sensor, the display will also show your heart rate.

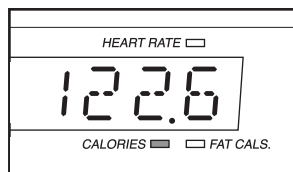

Note: The console can display speed and distance in either miles or kilometers. To find which unit of measurement is selected, you must select the console's user mode.

Hold down the Program Select button for about three seconds. The letter "E" for English miles or the letter "M" for metric kilometers will appear on the right side of the main display. To change the unit of measurement, press the Resistance 10 button.

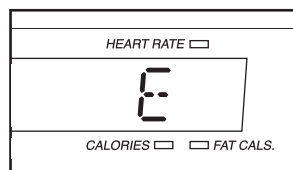

While the user mode is selected, press the iFIT.com button. The main display will then show the total number of hours that the elliptical exerciser has been used. Press the iFIT.com button again. The main display will then show the total number of miles pedaled. To exit the user mode, press the Program Select button again.

## 5 Measure your heart rate if desired.

To use the chest pulse sensor, see page 9. To use the handgrip pulse sensor, follow the instructions below. **Note: If you wear the chest pulse sensor and hold the handgrip pulse sensor at the same time, the console may not display your heart rate accurately.**

If there are thin sheets of plastic on the metal contacts on the handgrip pulse sensor, peel off the plastic. To measure your

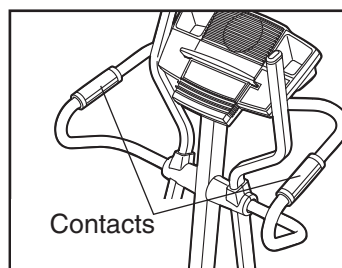

heart rate, hold the contacts; your palms must be resting on the upper contacts, and your fingers must be touching the lower contacts. **Avoid moving your hands.**

When your pulse is detected, the Heart Rate indicator above the right side of the main display will light, two dashes (--) will appear in the main display, and then your heart rate will be shown. For the most accurate heart rate reading, hold the contacts for at least 15 seconds.

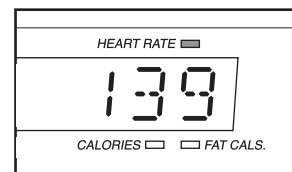

Note: If you continue to hold the contacts, the main display will show your heart rate for up to 30 seconds. The main display will then show your heart rate along with the other modes.

If your heart rate is not shown, make sure that your hands are positioned as described. Be careful not to move your hands excessively or to squeeze the contacts too tightly. For optimal performance, clean the contacts using a soft cloth; never use alcohol, abrasives, or chemicals.

## 6 Turn on the fan if desired.

To turn on the fan, press the Fan button. Pivot the fan to the desired angle. To turn on the fan at high speed, press the Fan button a second time. To turn off the fan, press the Fan button a third time.

## 7 When you are finished exercising, the console will automatically turn off.

If the pedals are not moved for several seconds, a tone will sound, the console will pause, and the time will begin to flash in the main display.

If the pedals are not moved for about five minutes, the console will turn off and the main display will be reset.

## HOW TO USE PERSONAL TRAINER PROGRAMS

### 1 Begin pedaling to activate the console.

See step 1 on page 13.

### 2 Select one of the 15 personal trainer programs.

When the power is turned on, the manual mode will be selected. To select a personal trainer program, repeatedly press the Program Select button until the name of the desired program appears in the main display.

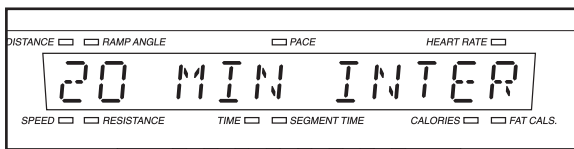

The matrix will show the first eight resistance settings of the program you have selected.

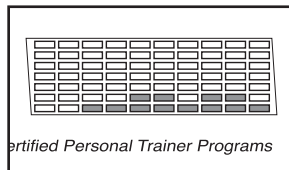

### 3 Begin pedaling to start the program.

Each program is divided into several time segments of different lengths. (The main display will show both the time remaining in the program and the time remaining in the current segment of the program.) One resistance setting and one pace setting are programmed for each segment. (The same resistance setting and/or pace setting may be programmed for two or more consecutive segments.)

The resistance setting for the first segment will be shown in the flashing Current Segment column of the matrix. (The pace settings are not shown in the matrix.) The resistance settings for the next several segments will be shown in the columns to the right.

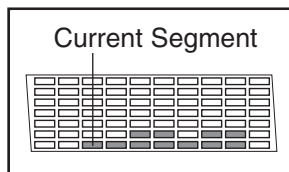

When only three seconds remain in the first segment of the program, both the Current Segment column and the column to the right will flash, a series of tones will sound, and *all resistance settings will move one column to the left*. The resistance setting for the second segment will then be shown in the flashing Current Segment column, and the resistance of the pedals will automatically change if a different resistance setting is programmed for the second segment.

As you exercise, the Training Zone bar will help you to keep your pedaling pace near the pace setting for the current segment. The lit indicators in the bar will show your actual pace.

If an indicator to the *right* of the lit indicators is flashing (see drawing a), increase your pace. If an indicator to the *left* of any lit indicator is flashing (see drawing b), decrease your pace. When no indicator is flashing, your pace matches the pace setting for the current segment. **Important:**

**The pace settings are intended only to provide motivation. Your actual pace may be slower than the current pace setting. Make sure to exercise at a pace that is comfortable for you.**

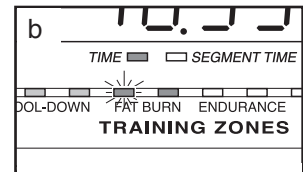
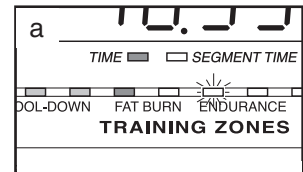

The program will continue in this way until the main display shows that no time remains in the program.

Note: During the program, you can override the resistance setting for the current segment, if desired, by pressing the Resistance buttons. However, when the next segment begins, the resistance will automatically change if a different resistance setting is programmed for the next segment. If you stop pedaling for several seconds, a tone will sound and the program will pause. To restart the program, simply resume pedaling.

**4 Monitor your progress with the main display.**

See step 4 on page 13.

**5 Measure your heart rate if desired.**

See step 5 on page 14.

**6 Turn on the fan if desired.**

See step 6 on page 14.

**7 When the program is finished, the console will automatically turn off.**

See step 7 on page 14.

**HOW TO USE HEART RATE PROGRAMS**

Each heart rate program helps you to keep your heart rate near a certain *percentage* of your *maximum heart rate* during your workout. Note: Your maximum heart rate is estimated by subtracting your age from 220. For example, if you are 30 years old, your maximum heart rate is 190 (220 – 30 = 190).

Heart rate program 1 will keep your heart rate between 50% and 80% of your maximum heart rate; heart rate program 2 will keep your heart rate between 55% and 85%; heart rate program 3 will keep your heart rate between 60% and 85%; heart rate program 4 will keep your heart rate between 50% and 85%.

Follow the steps below to use a heart rate program.

**1 Begin pedaling to activate the console.**

See step 1 on page 13.

**2 Select one of the four heart rate programs.**

When the power is turned on, the manual mode will be selected. To select a heart rate program, press the Program Select button repeatedly until the words “HEARTRATE 1,” “HEARTRATE 2,” “HEARTRATE 3,” or “HEARTRATE 4” appear in the main display.

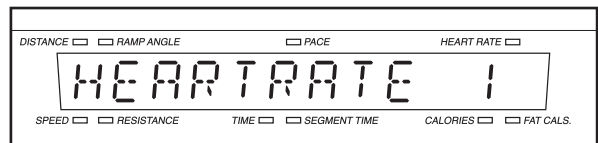

Three seconds after a program is selected, the name of the selected program and the total program time will scroll across the main display. The current age setting will then begin to flash in the main display.

During heart rate programs, the matrix will show a graphic that represents your heart rate. Each time a heartbeat is detected, an additional peak will appear.

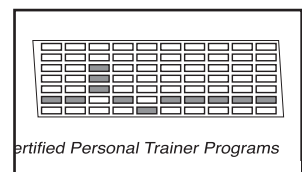



### 3 Enter your age.

You must enter your age to use a heart rate program. If you have already entered your age, press the Enter button and go to step 4. If you have not entered your age, press the Up Arrow or Down Arrow button repeatedly to enter your age, and then press the Enter button. Once you have entered your age, it will be saved in memory.

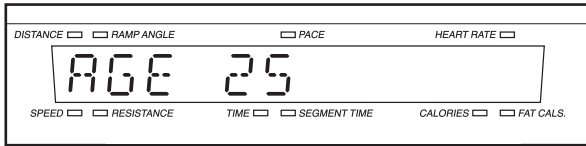

### 4 Wear the chest pulse sensor or hold the handgrip pulse sensor.

To use the chest pulse sensor, see page 9.

To use the handgrip pulse sensor, it is not necessary to hold the handgrips continuously during the program. However, you should hold the handgrips frequently for the program to operate properly. **Each time you hold the handgrips, keep your hands on the metal contacts for at least 30 seconds.** Note: When you are not holding the handgrips, the letters "PLS" will appear in the right side of the display instead of your heart rate.

### 5 Begin pedaling to start the program.

Each heart rate program consists of 20 one-minute segments. (The main display will show both the time remaining in the program and the time remaining in the current segment of the program.) One resistance setting is programmed for each segment. (The same resistance setting may be programmed for two or more consecutive segments.)

At the end of each segment, a series of tones will sound. The resistance of the pedals will then change if a different resistance setting is programmed for the next segment. Note: If the resistance is too high or too low, you can adjust the resistance by pressing the Resistance buttons. However, when the next segment begins, the resistance will automatically change if a different resistance setting is programmed for the next segment.

As you exercise, the Training Zone bar will help you to keep your heart rate near the current target heart rate for the program. The lit indicators in the bar will show your actual pace. When you wear the chest pulse sensor or hold the handgrip pulse sensor, the console will periodically compare your heart rate to the current target heart rate; if necessary, an indicator in the bar will then flash to prompt you

to increase or decrease your pace to bring your heart rate closer to the current target heart rate. If an indicator to the *right* of the lit indicators is flashing (see drawing a), increase your pace. If an indicator to the *left* of any lit indicator is flashing (see drawing b), decrease your pace.

When no indicator is flashing, your heart rate is near the current target heart rate. **Important: The target heart rates are intended only to provide motivation. Your actual heart rate may be slower than the current target heart rate. Make sure to exercise at a pace that is comfortable for you.**

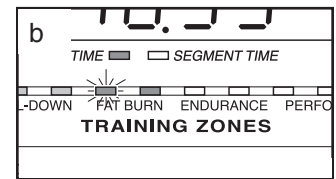
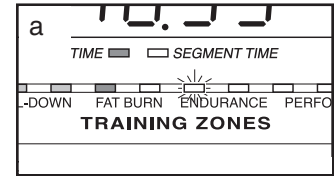

The program will continue in this way until the main display shows that no time remains in the program.

Note: If you stop pedaling for several seconds, a tone will sound and the program will end. Heart rate programs cannot be stopped temporarily and then restarted.

### 6 Monitor your progress with the main display.

See step 4 on page 13.

### 7 Turn on the fan if desired.

See step 6 on page 14.

### 8 When the program is finished, the console will automatically turn off.

See step 7 on page 14.

## HOW TO CONNECT YOUR CD PLAYER, VCR, OR COMPUTER

To use **iFIT.com CDs**, the elliptical exerciser must be connected to your portable CD player, portable stereo, home stereo, or computer with CD player. See pages 18 and 19 for connecting instructions. To use **iFIT.com videocassettes**, the elliptical exerciser must be connected to your VCR. See page 20 for connecting instructions. To use **iFIT.com programs directly from our Web site**, the elliptical exerciser must be connected to your home computer. See page 19 for connecting instructions.

## HOW TO CONNECT YOUR PORTABLE CD PLAYER

**Note:** If your CD player has separate **LINE OUT** and **PHONES** jacks, see instruction A below. If your CD player has only one jack, see instruction B.

- A. Plug one end of the audio cable into the jack beneath the console. Plug the other end of the cable into the **LINE OUT** jack on your CD player. Plug your headphones into the **PHONES** jack.

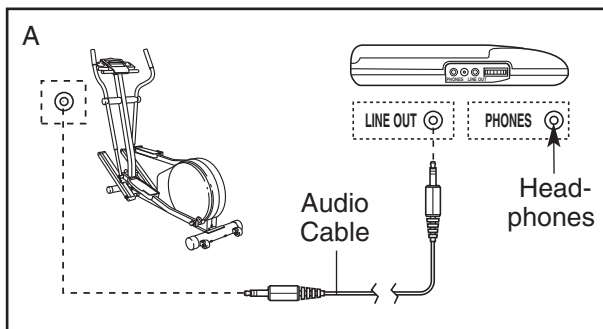

- B. Plug one end of the audio cable into the jack beneath the console. Plug the other end of the cable into a 1/8" Y-adapter (available at electronics stores). Plug the Y-adapter into the **PHONES** jack on your CD player. Plug your headphones into the other side of the Y-adapter.

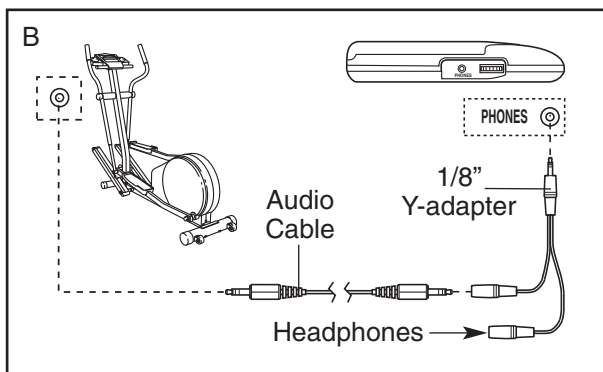

## HOW TO CONNECT YOUR PORTABLE STEREO

**Note:** If your stereo has an **RCA-type AUDIO OUT** jack, see instruction A below. If your stereo has a 1/8" **LINE OUT** jack, see instruction B. If your stereo has only a **PHONES** jack, see instruction C.

- A. Plug one end of the audio cable into the jack beneath the console. Plug the other end of the cable into the adapter. Plug the adapter into an **AUDIO OUT** jack on your stereo.

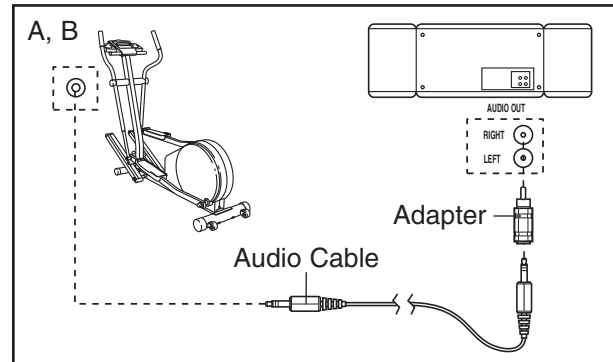

- B. Plug one end of the audio cable into the jack beneath the console. Plug the other end of the cable into the **LINE OUT** jack on your stereo. Do not use the adapter.

- C. Plug one end of the audio cable into the jack beneath the console. Plug the other end of the cable into a 1/8" Y-adapter (available at electronics stores). Plug the Y-adapter into the **PHONES** jack on your stereo. Plug your headphones into the other side of the Y-adapter.

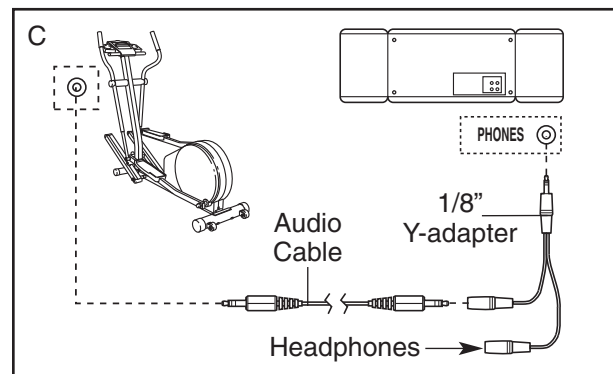

## HOW TO CONNECT YOUR HOME STEREO

**Note:** If your stereo has an unused **LINE OUT** jack, see instruction **A** below. If the **LINE OUT** jack is being used, see instruction **B**.

- A. Plug one end of the audio cable into the jack beneath the console. Plug the other end of the cable into the adapter. Plug the adapter into the **LINE OUT** jack on your stereo.

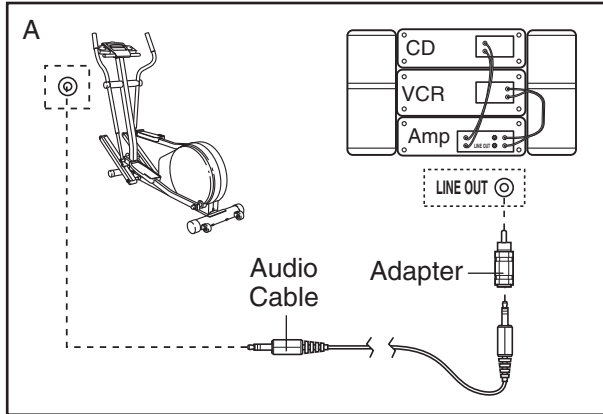

- B. Plug one end of the audio cable into the jack beneath the console. Plug the other end of the cable into the adapter. Plug the adapter into an **RCA Y-adapter** (available at electronics stores). Next, remove the wire that is currently plugged into the **LINE OUT** jack on your stereo and plug the wire into the unused side of the Y-adapter. Plug the Y-adapter into the **LINE OUT** jack on your stereo.

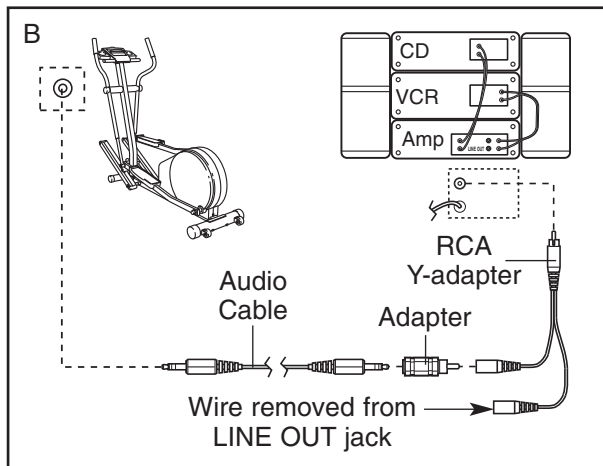

## HOW TO CONNECT YOUR COMPUTER

**Note:** If your computer has a **1/8" LINE OUT** jack, see instruction **A**. If your computer has only a **PHONES** jack, see instruction **B**.

- A. Plug one end of the audio cable into the jack beneath the console. Plug the other end of the cable into the **LINE OUT** jack on your computer.

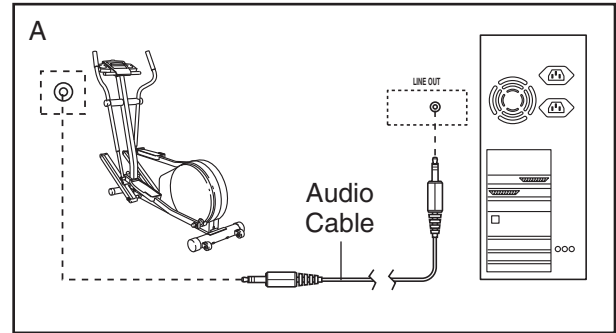

- B. Plug one end of the audio cable into the jack beneath the console. Plug the other end of the cable into a **1/8" Y-adapter** (available at electronics stores). Plug the Y-adapter into the **PHONES** jack on your computer. Plug your headphones or speakers into the other side of the Y-adapter.

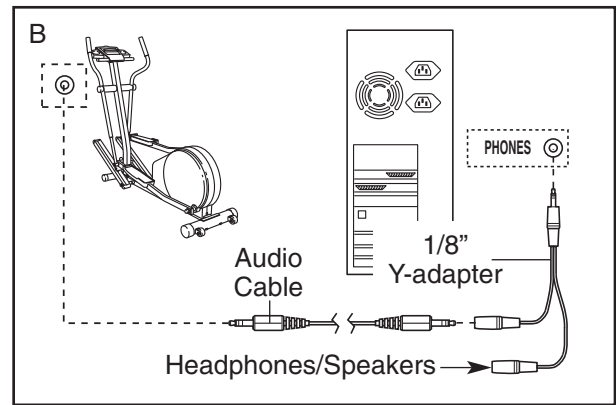

## HOW TO CONNECT YOUR VCR

**Note: If your VCR has an unused AUDIO OUT jack, see instruction A below. If the AUDIO OUT jack is being used, see instruction B. If you have a TV with a built-in VCR, see instruction B. If your VCR is connected to your home stereo, see HOW TO CONNECT YOUR HOME STEREO on page 19.**

- A. Plug one end of the audio cable into the jack beneath the console. Plug the other end of the cable into the adapter. Plug the adapter into the AUDIO OUT jack on your VCR.

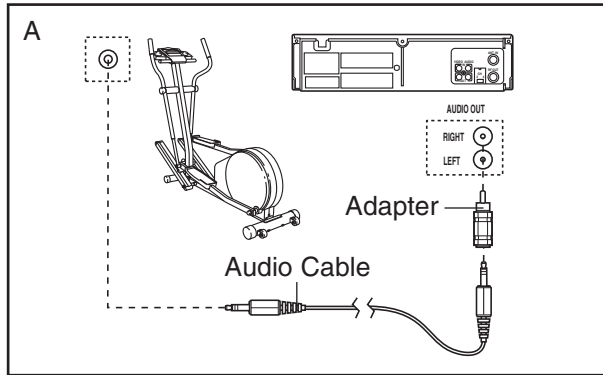

- B. Plug one end of the audio cable into the jack beneath the console. Plug the other end of the cable into the adapter. Plug the adapter into an RCA Y-adapter (available at electronics stores). Next, remove the wire that is currently plugged into the AUDIO OUT jack on your VCR and plug the wire into the unused side of the Y-adapter. Plug the Y-adapter into the AUDIO OUT jack on your VCR.

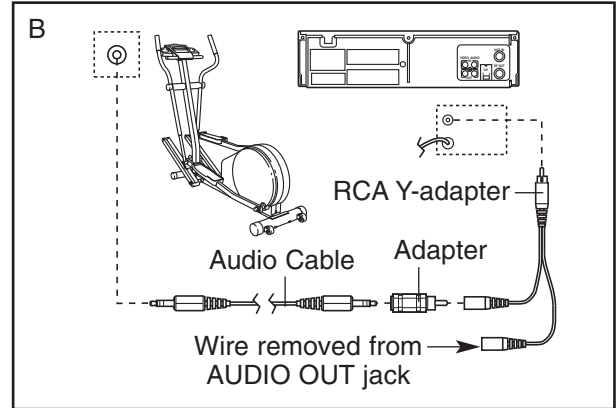

## HOW TO USE iFIT.COM CD AND VIDEO PROGRAMS

To use iFIT.com CDs or videocassettes, the elliptical exerciser must be connected to your portable CD player, portable stereo, home stereo, computer with CD player, or VCR. See HOW TO CONNECT YOUR CD PLAYER, VCR, OR COMPUTER on page 18. **To purchase iFIT.com CDs and videocassettes, call toll-free 1-800-735-0768.**

Follow the steps below to use an iFIT.com CD or video program.

### 1 Begin pedaling to activate the console.

See step 1 on page 13.

### 2 Select the iFIT.com mode.

When the console is turned on, the manual mode will be selected. To select the iFIT.com mode, press the iFIT.com button. The indicator above the button will light and the words "iFIT MODE" will appear in the main display.

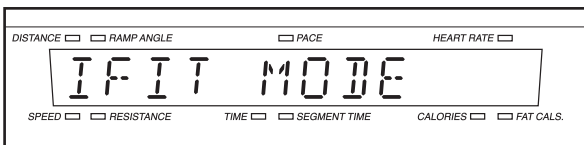

### 3 Insert the iFIT.com CD or videocassette.

If you are using an iFIT.com CD, insert the CD into your CD player. If you are using an iFIT.com videocassette, insert the videocassette into your VCR.

### 4 Press the play button on your CD player or VCR.

A moment after the play button is pressed, your personal trainer will begin guiding you through your workout. Simply follow your personal trainer's instructions.

The program will function in almost the same way as a personal trainer program (see step 3 on page 15). However, an electronic "chirping" sound will alert you when the resistance setting and/or the pace setting is about to change.

**Note: If the resistance of the pedals and/or the pace setting does not change when a "chirp" is heard:**

- Make sure that the indicator above the iFIT.com button is lit.
- Adjust the volume of your CD player or VCR. If the volume is too high or too low, the console may not detect the program signals.
- Make sure that the audio cable is properly connected and that it is fully plugged in.

### 5 Monitor your progress with the main display.

See step 4 on page 13.

### 6 Measure your heart rate if desired.

See step 5 on page 14.

### 7 Turn on the fan if desired.

See step 6 on page 14.

### 8 When the program is finished, the console will automatically turn off.

See step 7 on page 14.

## HOW TO USE PROGRAMS DIRECTLY FROM OUR WEB SITE

Our Web site at [www.iFIT.com](http://www.iFIT.com) allows you to play iFIT.com audio and video programs directly from the internet. To use programs from our Web site, the elliptical exerciser must be connected to your home computer. See HOW TO CONNECT YOUR COMPUTER on page 19. In addition, you must have an internet connection and an internet service provider. A list of specific system requirements will be found on our Web site.

Follow the steps below to use a program from our Web site.

### 1 Begin pedaling to activate the console.

See step 1 on page 13.

### 2 Select the iFIT.com mode.

When the console is turned on, the manual mode will be selected. To select the iFIT.com mode, press the iFIT.com button. The indicator above the button will light and the words "iFIT MODE" will appear in the main display.

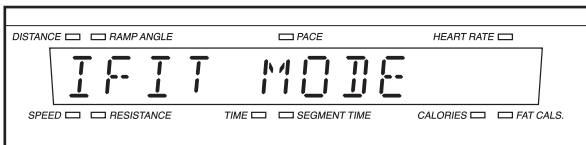

### 3 Go to your computer and start an internet connection.

### 4 Start your Web browser, if necessary, and go to our Web site at [www.iFIT.com](http://www.iFIT.com).

### 5 Follow the desired links on our Web site to select a program.

Read and follow the on-line instructions for using a program.

### 6 Follow the on-line instructions to start the program.

When you start the program, an on-screen countdown will begin.

### 7 Return to the elliptical exerciser and begin pedaling.

When the on-screen countdown ends, the program will begin. The program will function in almost the same way as a personal trainer program (see step 3 on page 15). However, an electronic "chirping" sound will alert you when the resistance setting and/or the pace setting is about to change.

### 8 Monitor your progress with the main display.

See step 4 on page 13.

### 9 Measure your heart rate if desired.

See step 5 on page 14.

### 10 Turn on the fan if desired.

See step 6 on page 14.

### 11 When you are finished exercising, the console will automatically turn off.

See step 7 on page 14.

## HOW TO MEASURE YOUR BODY FAT PERCENTAGE

**⚠ CAUTION:** The console uses a bioelectrical impedance analysis method to determine body fat percentage, sending a harmless signal through the body. Do not measure your body fat percentage if you have an internal medical device such as a pacemaker. Consult your physician if you have questions.

Follow the steps below to measure your body fat percentage.

### **1** Begin pedaling to activate the console.

See step 1 on page 13.

### **2** Press the Measure button.

When the Measure button is pressed, the words “THIS PROGRAM MEASURES YOUR BODY FAT PERCENT” and “USE UP/DOWN ARROWS TO SCROLL AND ‘ENTER’ TO SELECT” will scroll across the main display.

Before the console measures your body fat percentage, it will prompt you to enter personal data such as your age and weight. Use the Up Arrow, Down Arrow, and Enter buttons to enter information. Note: The information that appears in the main display will flash until it is modified.

### **3** Enter your user number.

The console can save personal data for three different users. The words “USER 1” will appear in the main display. To designate yourself as user 1, press the Enter button. To designate yourself as user 2 or user 3, press the Up Arrow button until the words “USER 2” or “USER 3” appear in the main display. Then, press the Enter button.

### **4** Enter your age.

If you have already entered your age, simply press the Enter button. If you have not entered your age, press the Up Arrow or Down Arrow button to enter your age, and then press the Enter button.

### **5** Enter your height.

If you have already entered your height, press the Enter button. If you have not entered your height, press the Up Arrow or Down Arrow button to enter your height, and then press the Enter button.

### **6** Enter your weight.

If you have already entered your weight, press the Enter button. If you have not entered your weight, press the Up Arrow or Down Arrow button to enter your weight, and then press the Enter button.

### **7** Enter your gender.

If you have already entered your gender (“F” for female or “M” for male), press the Enter button. If you have not entered your gender, press the Up Arrow or Down Arrow button, and then press the Enter button.

### **8** Enter the number of times that you exercise per week.

If you have already entered the number of times that you exercise per week, press the Enter button. If you have not entered the number, press the Up Arrow or Down Arrow button to enter the number, and then press the Enter button.

Note: If you wish to change any of the information that you have entered, press the Left Arrow or Right Arrow button until the desired information appears in the main display. Then, change the information by pressing the Up Arrow, Down Arrow, and Enter buttons.

### **9** Hold the handgrip pulse sensor.

When you hold the handgrip pulse sensor, the main display will begin a 10-second countdown. When the countdown ends, your body fat percentage will appear in the main display.

If you wish to receive a custom workout based on the personal data that you have entered, see HOW TO USE A CUSTOM PROGRAM on page 24.

If you wish to view your progress during recent workouts, see HOW TO CHART YOUR PROGRESS on page 25.

## HOW TO USE A CUSTOM PROGRAM

In addition to offering personal trainer programs, the console can provide custom fat burn, weight loss, or cardio programs based on the personal data that you have entered. Follow the steps below to use a custom program.

### 1 Begin pedaling to activate the console.

See step 1 on page 13.

### 2 Press the Program button.

When the Program button is pressed, the words "TO RECEIVE A CUSTOM WORKOUT BASED ON YOUR PERSONAL INFO, USE UP/DOWN ARROWS TO SCROLL AND 'ENTER' TO SELECT" will scroll across the main display.

### 3 Select a custom Fat Burn, Weight Loss, or Cardio program.

To receive a custom Fat Burn program, press the Enter button. To receive a custom Weight Loss program or Cardio program, press the Up Arrow button and then press the Enter button.

### 4 Enter your user number.

See step 3 on page 23.

**If you selected a Fat Burn program,** the main display will show the latest measurement of your body fat percentage.

**If you selected a Weight Loss program,** the main display will show the latest body weight that you have entered.

If there has been a change in any of the personal data that you have entered, such as your weight, press the Measure button while the words "IF YOU WISH TO CHANGE USER INFO PRESS 'MEASURE' NOW" appear in the main display. Then, make the necessary changes. (See HOW TO MEASURE YOUR BODY FAT PERCENTAGE on page 23.)

### 5 Enter a goal.

**If you selected a Fat Burn program,** the main display will show a body fat goal. If you have already entered a body fat goal, press the Enter button. To change the body fat goal, press the Up Arrow or Down Arrow button, and then press the Enter button. Note: The body fat goal must be at least 5%.

**If you selected a Weight Loss program,** the main display will show a body weight goal. If you have already entered a body weight goal, press the Enter button. To change the body weight goal, press the Up Arrow or Down Arrow button, and then press the Enter button.

**If you selected a Cardio program,** it is not necessary to enter a goal.

### 6 Select an intensity level for the program.

To select an intensity level for the program, first press the Up Arrow or Down Arrow button until the words "EASY," "MODERATE," "HARD," or "INTENSE" appear in the main display. Then, press the Enter button.

The maximum resistance setting of the custom program will then appear in the main display.

### 7 Press the Enter button to start the program.

The custom program will function in the same way as a personal trainer program. (See step 3 on page 15.)

When you have completed the program, the words "END OF PROGRAM" will appear in the main display.

If you wish to measure your body fat percentage, see HOW TO MEASURE YOUR BODY FAT PERCENTAGE on page 23.

If you wish to view your progress during recent workouts, see HOW TO CHART YOUR PROGRESS on page 25.



## HOW TO CHART YOUR PROGRESS

### 1 Begin pedaling to activate the console.

See step 1 on page 13.

### 2 Press the Progress button.

When the Progress button is pressed, the words "TO CHART YOUR PROGRESS USE UP/DOWN ARROWS TO SCROLL AND 'ENTER' TO SELECT" will scroll across the main display.

### 3 Enter your user number.

See step 3 on page 23.

### 4 Change your personal data if desired.

If there has been a change in any of the personal data that you have entered, such as your weight, press the Measure button while the words "IF YOU WISH TO CHANGE USER INFO PRESS 'MEASURE' NOW" appear in the main display. Then, make the necessary changes. (See HOW TO MEASURE YOUR BODY FAT PERCENTAGE on page 23.)

### 5 Select a fat burn chart or a weight loss chart.

For the console to display a chart showing your fat burning progress, press the Enter button. For the console to display a chart showing your weight loss progress, press the Up Arrow button and then press the Enter button.

### 6 View your progress chart in the matrix.

If you selected a fat burn chart, the matrix will display a chart that shows your latest ten body fat measurements compared to your body fat goal. The bottom of the chart represents your body fat goal; when only one indicator is lit in a column, you have reached your goal. The chart above, for example, shows that your body fat percentage is decreasing but that you have not yet reached your goal.

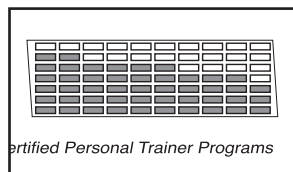

The main display will show the latest measurement of your body fat percentage, your body fat goal, and the number of times that you should exercise per week. Note: If you have not measured your body fat percentage (see page 23), the console will automatically assign a body fat percentage of 0%. If you have not entered a body fat goal (see step 5 on page 24), the console will automatically assign a goal of 20% body fat.

If you selected a weight loss chart, the matrix will display a chart that shows your latest ten body weight measurements compared to your body weight goal. The bottom of the chart represents your body weight goal; when only one indicator is lit in a column, you have reached your goal. The chart above, for example, shows that your body weight has decreased and that you have reached your goal.

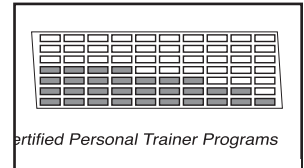

The main display will show the latest body weight that you have entered, your body weight goal, and the number of times that you should exercise per week. Note: If you have not entered your body weight (see step 6 on page 23), the console will automatically assign a body weight of 150 pounds. If you have not entered a body weight goal (see step 5 on page 24), the console will automatically assign a goal of 140 pounds.

### 7 Reset the chart if desired.

After you have viewed the chart, the words "GRAPH RESET YES/NO" will appear in the main display. To delete your last ten body fat or body weight measurements, press the Up Arrow (yes) button. If you do not wish to reset the chart, press the Down Arrow (no) button.

If you wish to measure your body fat percentage, see HOW TO MEASURE YOUR BODY FAT PERCENTAGE on page 23.

If you wish to receive a custom workout based on the personal data you have entered, see HOW TO USE A CUSTOM PROGRAM on page 24.

# MAINTENANCE AND TROUBLESHOOTING

Inspect and properly tighten all parts of the elliptical exerciser regularly. Replace any worn parts immediately.

For smooth operation of the elliptical exerciser, **inspect and clean the incline ramp regularly** using a soft cloth and mild detergent. Other parts of the elliptical exerciser can also be cleaned in this way. **Keep liquids off the console. Never use abrasives or solvents.**

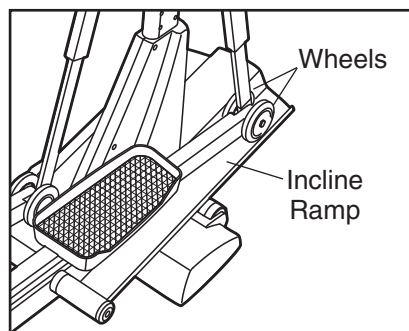

## PULSE SENSOR TROUBLESHOOTING

If the chest pulse sensor does not function properly, see CHEST PULSE SENSOR TROUBLESHOOTING on pages 9 and 10. If the handgrip pulse sensor does not function properly, see step 5 on page 14.

## HOW TO CALIBRATE THE INCLINE RAMP

If the elliptical exerciser's incline ramp does not function properly, activate the calibration process by following the steps below.

1. Hold down the Resistance 1 button and the Program Select button simultaneously for about five seconds. Note: If numbers appear in the main display, disregard the numbers.
2. Press the Program Select button again. Note: A combination of letters and numbers may appear in the main display.
3. Press the 10° or 30° Ramp button. The ramp will move all of the way up and then all of the way down.
4. Press the Program Select button three times. The console will then be in the normal operating mode and the elliptical exerciser will be ready for use.

## HOW TO MOVE THE ELLIPTICAL EXERCISER

Stand in front of the elliptical exerciser, hold the handlebars firmly, and place one foot against the ramp in the location shown below. Pull the handlebars until the elliptical exerciser can be moved on the front wheels, and carefully move the elliptical exerciser to the desired location. Then, place one foot against the ramp, and lower the elliptical exerciser. **Due to the size and weight of the elliptical exerciser, use extreme caution while moving and lowering it.**

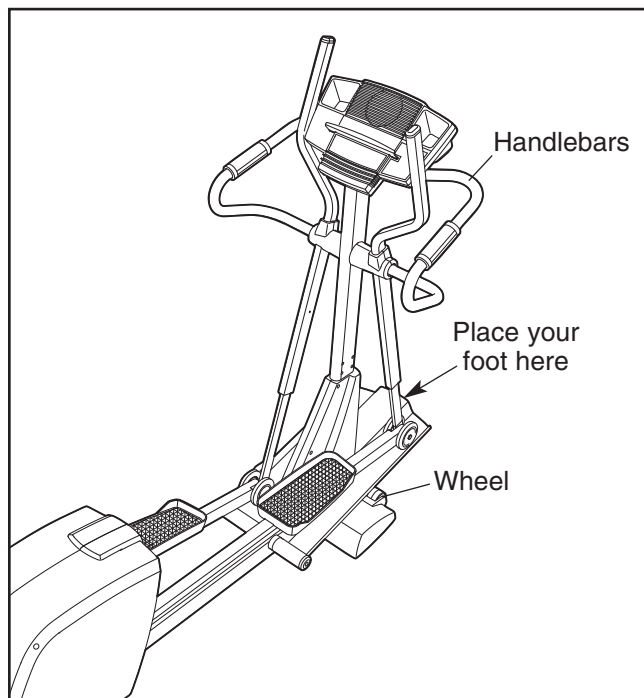

## HOW TO LEVEL THE ELLIPTICAL EXERCISER

If the elliptical exerciser rocks during use, turn one or both of the leveling feet under the rear stabilizer until the rocking motion is eliminated.

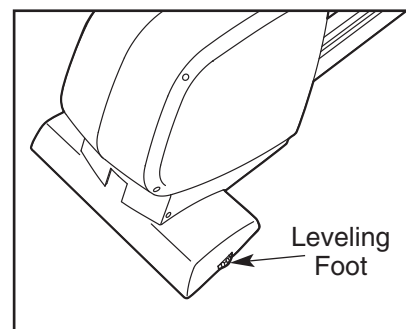

# CONDITIONING GUIDELINES

## WARNING:



Before beginning this or any exercise program, consult your physician. This is especially important for persons over the age of 35 or persons with pre-existing health problems.

The pulse sensors are not medical devices. Various factors, including the user's movement, may affect the accuracy of heart rate readings. The pulse sensors are intended only as exercise aids in determining heart rate trends in general.

The following guidelines will help you to plan your exercise program. Remember that proper nutrition and adequate rest are essential for successful results.

## EXERCISE INTENSITY

Whether your goal is to burn fat or to strengthen your cardiovascular system, the key to achieving the desired results is to exercise with the proper intensity. The proper intensity level can be found by using your heart rate as a guide. The chart below shows recommended heart rates for fat burning, maximum fat burning, and cardiovascular (aerobic) exercise.

165	155	145	140	130	125	115	
145	138	130	125	118	110	103	
125	120	115	110	105	95	90	
20	30	40	50	60	70	80	

To find the proper heart rate for you, first find your age at the bottom of the chart (ages are rounded off to the nearest ten years). Next, find the three numbers above your age. The three numbers are your “training zone.” The lower two numbers are recommended heart rates for fat burning; the highest number is the recommended heart rate for aerobic exercise.

## Fat Burning

To burn fat effectively, you must exercise at a relatively low intensity level for a sustained period of time.

During the first few minutes of exercise, your body uses easily accessible *carbohydrate* calories for energy. Only after the first few minutes of exercise does your body begin to use stored *fat* calories for energy. If your goal is to burn fat, adjust the intensity of your exercise until your heart rate is near the lowest number in your training zone as you exercise.

For maximum fat burning, adjust the intensity of your exercise until your heart rate is near the middle number in your training zone as you exercise.

## Aerobic Exercise

If your goal is to strengthen your cardiovascular system, your exercise must be “aerobic.” Aerobic exercise is activity that requires large amounts of oxygen for prolonged periods of time. This increases the demand on the heart to pump blood to the muscles, and on the lungs to oxygenate the blood. For aerobic exercise, adjust the intensity of your exercise until your heart rate is near the highest number in your training zone as you exercise.

## WORKOUT GUIDELINES

Each workout should include the following three parts:

**A warm-up**, consisting of 5 to 10 minutes of stretching and light exercise. A proper warm-up increases your body temperature, heart rate, and circulation in preparation for exercise.

**Training zone exercise**, consisting of 20 to 30 minutes of exercising with your heart rate in your training zone. (During the first few weeks of your exercise program, do not keep your heart rate in your training zone for longer than 20 minutes.)

**A cool-down**, with 5 to 10 minutes of stretching. This will increase the flexibility of your muscles and will help to prevent post-exercise problems.

## EXERCISE FREQUENCY

To maintain or improve your condition, complete three workouts each week, with at least one day of rest between workouts. After a few months of regular exercise, you may complete up to five workouts each week if desired. The key to success is to make exercise a regular and enjoyable part of your everyday life.

# PART LIST—Model No. NTE13921

R0304A

Key No.	Qty.	Description	Key No.	Qty.	Description
1	1	Frame	54	1	Clamp
2	1	Upright	55	1	Reed Switch/Wire
3	1	Ramp	56	1	Return Spring
4	1	Left Pedal Leg	57	1	Guide Rod
5	1	Right Pedal Leg	58	1	Resistance Cable
6	1	Rear Stabilizer	59	1	Flywheel Axle
7	1	Rear Stabilizer Cover	60	2	Flywheel Bearing
8	1	Front Stabilizer	61	2	Eye Bolt
9	1	Front Stabilizer Cover	62	2	Adjustment Bracket
10	1	Left Pedal	63	2	M8 x 47mm Button Screw
11	1	Right Pedal	64	2	M6 Washer
12	1	Incline Motor	65	2	M10 x 78mm Bolt Set
13	1	Incline Axle	66	2	M8 Washer
14	1	Pivot Axle	67	2	M10 x 50mm Bolt Set
15	1	Left Side Shield	68	2	Handlebar Bushing
16	1	Right Side Shield	69	10	M4 x 16mm Tek Screw
17	1	Console	70	2	M10 x 110mm Button Screw
18	1	Right Flywheel Cover	71	1	M8 Tek Washer
19	1	Left Flywheel Cover	72	1	M11 x 40mm Bolt Set
20	2	Pulse Sensor w/Wire	73	2	M10 Split Washer
21	1	Right Incline Cover	74	1	M8 x 25mm Button Bolt
22	1	Left Incline Cover	75	1	M10 x 19mm Button Bolt
23	1	Right Handlebar	76	8	M6 x 16mm Patch Screw
24	1	Left Handlebar	77	4	M5 Nut
25	1	Upper Handlebar Cover	78	4	M5 x 16mm Bolt
26	2	Handlebar Cover	79	4	M5 Washer
27	1	Frame Cover	80	2	M6 x 18mm Bolt
28	4	Pedal Wheel	81	1	M6 x 25mm Bolt
29	8	Wheel Bearing	82	2	5/16" x 25mm Flange Screw
30	2	Wheel Frame	83	4	M8 x 58mm Button Screw
31	1	Left Upper Body Leg	84	8	M8 x 44mm Button Screw
32	1	"C" Magnet	85	4	M8 x 41mm Button Bolt
33	1	Magnet Bracket	86	6	M8 Jam Nut
34	1	Left Crank Arm	87	8	M4 x 38mm Screw
35	2	28.7mm Pulley Spacer	88	3	M8 Nylon Locknut
36	1	Flywheel	89	1	M10 Nylon Locknut
37	1	Magnet	90	3	M6 Nut
38	1	Pulley	91	2	M6 Nylon Locknut
39	1	Control Box Cover	92	2	Snap Ring
40	1	Control Board	93	2	M8 x 54mm Button Screw
41	1	Control Box	94	3	M4 x 10mm Screw
42	1	Lower Wire Harness	95	6	M4 x 19mm Screw
43	1	Crank	96	1	M4 x 12mm Round Head Screw
44	2	Crank Bearing	97	2	M4 x 25mm Screw
45	1	Idler	98	15	M4 x 16mm Screw
46	4	Foot	99	2	Ramp Spacer
47	4	Ramp Bushing	100	4	M5 Nylon Locknut
48	2	Ramp Cover	101	2	31.5mm Pulley Spacer
49	1	Incline Sensor	102	1	Right Crank Arm
50	1	Sensor Cover	103	1	Flywheel Spacer
51	4	Pedal Leg Bushing	104	2	Support Plate
52	1	Resistance Motor	105	2	M8 x 38mm Button Bolt
53	1	Reed Switch Bracket	106	2	Upper Foam Grip

Key No.	Qty.	Description	Key No.	Qty.	Description
107	2	Lower Foam Grip	119	2	Weld Spacer
108	3	M4 x 25mm Tek Screw	120	2	Sleeve
109	2	7.6mm Spacer	121	2	Upper Body Foam Grip
110	6	Wheel Bushing	122	2	Upper Body Endcap
111	2	M8 x 19mm Patch Screw	123	4	Upper Body Bushing
112	2	Wheel	124	2	M5 x 4mm Screw
113	1	Belt	125	1	Right Upper Body Leg
114	1	Pulse Extension Wire	126	2	M10 Washer
115	1	Upper Wire Harness	127	1	Nylon Zip Tie
116	1	Power Cord	#		Allen Wrench
117	1	Power Socket	#		User's Manual
118	2	Upper Body Arm			

Note: # indicates a non-illustrated part. Specifications are subject to change without notice. See the back cover of this manual for information about ordering replacement parts.

# EXPLODED DRAWING—Model No. NTE13921

R0304A

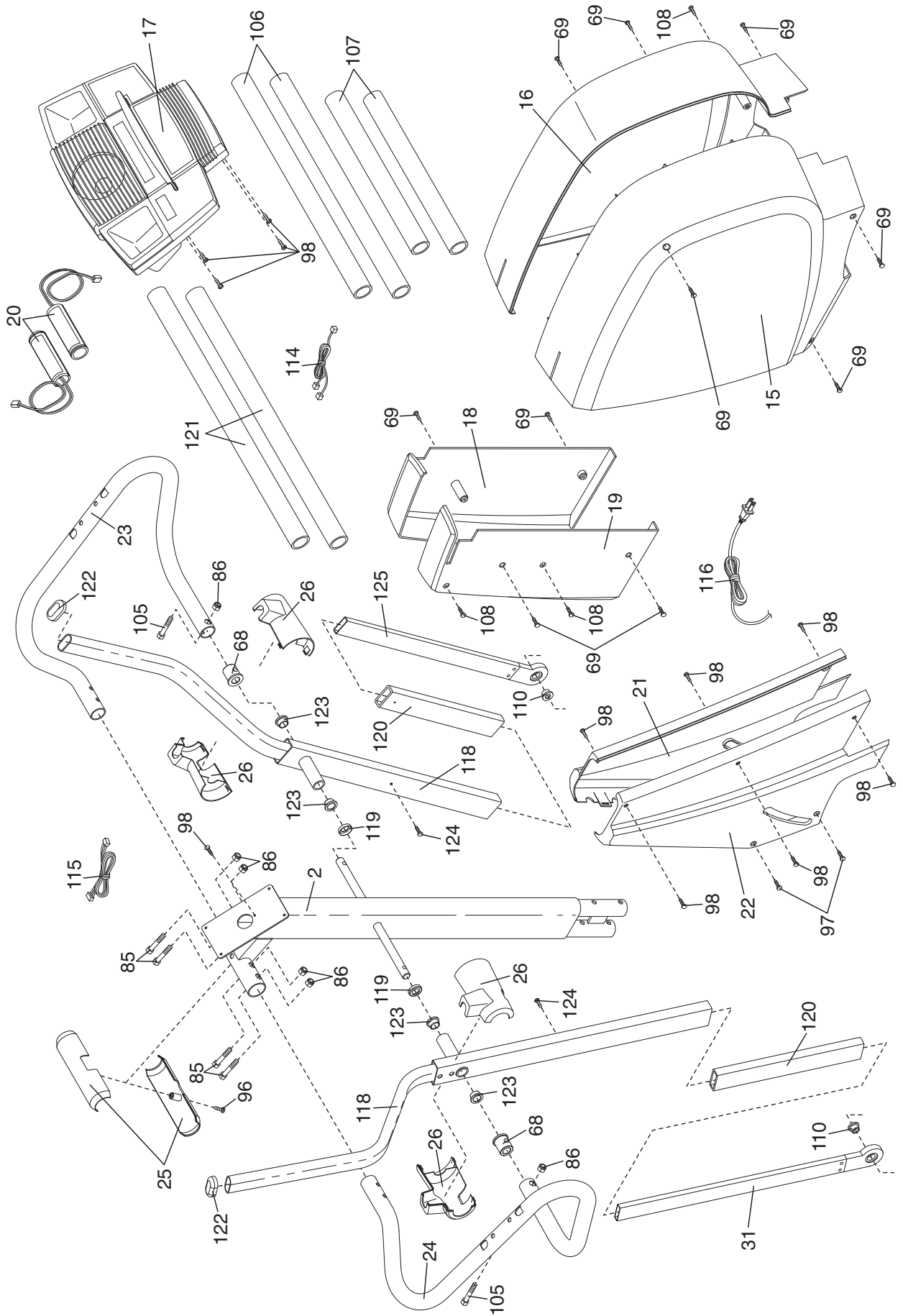

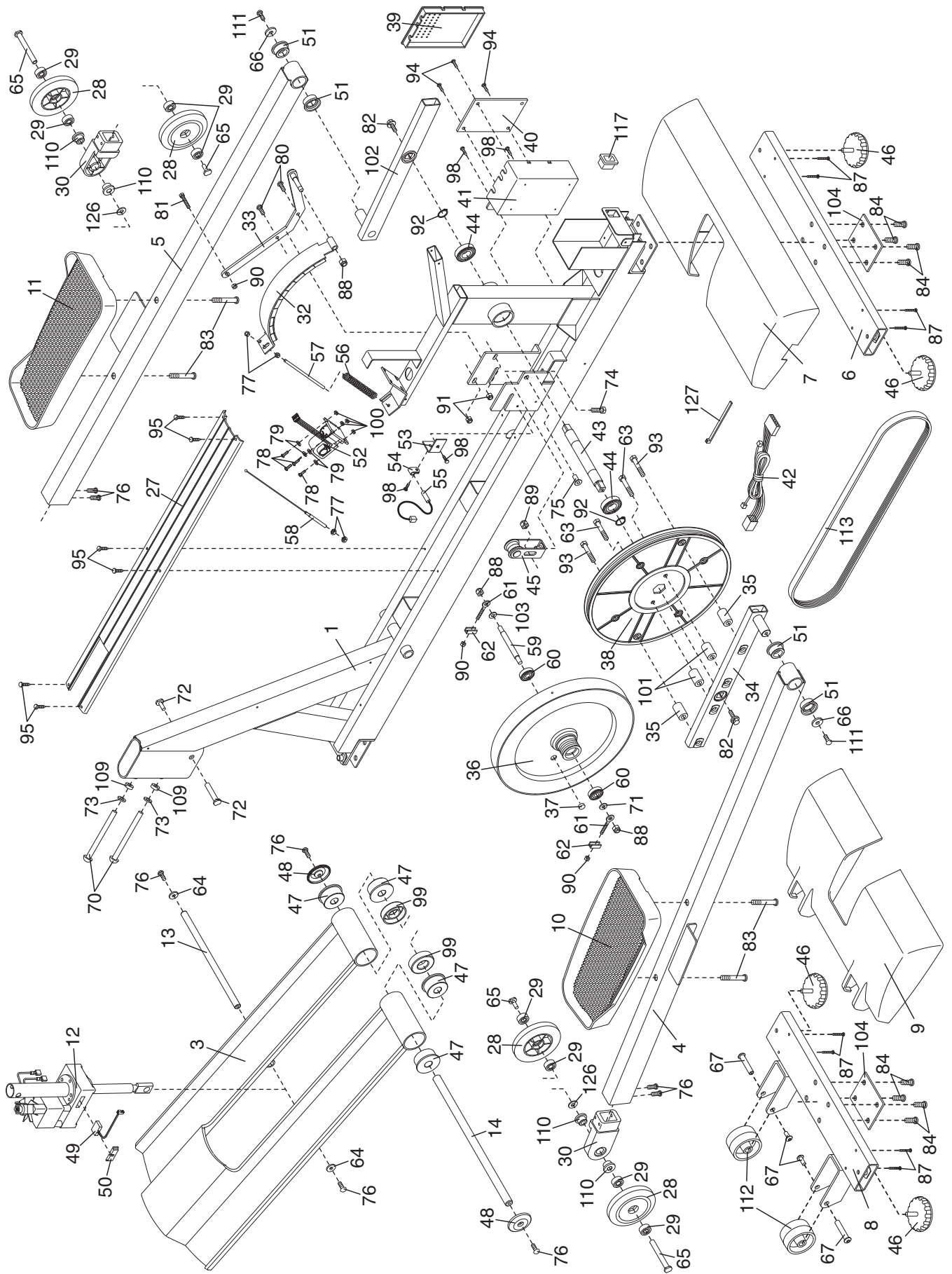

# HOW TO ORDER REPLACEMENT PARTS

To order replacement parts, simply call our Customer Service Department toll-free at 1-888-825-2588, Monday through Friday, 6 a.m. until 6 p.m. Mountain Time (excluding holidays). To help us assist you, please be prepared to give the following information when calling:

- The MODEL NUMBER of the product (NTE13921)
- The NAME of the product (NordicTrack® CX 995 elliptical exerciser)
- The SERIAL NUMBER of the product (see the front cover of this manual)
- The KEY NUMBER and DESCRIPTION of the part(s) (see pages 28 to 31)

## LIMITED WARRANTY

**WHAT IS COVERED**—The entire NordicTrack® elliptical exerciser (“Product”) is warranted to be free of all defects in material and workmanship.

**WHO IS COVERED**—The original purchaser or any person receiving the Product as a gift from the original purchaser.

**HOW LONG IS IT COVERED**—ICON Health & Fitness, Inc. (“ICON”), warrants the product for one year after the date of purchase. Labor is covered for one year.

**WHAT WE DO TO CORRECT COVERED DEFECTS**—We will ship to you, without charge, any replacement part or component, providing the repairs are authorized by ICON first and are performed by an ICON trained and authorized service provider, or, at our option, we will replace the Product.

**WHAT IS NOT COVERED**—Any failures or damage caused by unauthorized service, misuse, accident, negligence, improper assembly or installation, alterations, modifications without our written authorization or by failure on your part to use, operate, and maintain as set out in your User’s Manual (“Manual”).

**WHAT YOU MUST DO**—Always retain proof of purchase, such as your bill of sale; store, operate, and maintain the Product as specified in the Manual; notify our Customer Service Department of any defect within 10 days after discovery of the defect; as instructed, return any defected part for replacement or, if necessary, the entire product, for repair.

**USER’S MANUAL**—It is VERY IMPORTANT THAT YOU READ THE MANUAL before operating the Product. Remember to do the periodic maintenance requirements specified in the Manual to assure proper operation and your continued satisfaction.

**HOW TO GET PARTS AND SERVICE**—Simply call our Customer Service Department at 1-888-825-2588 and tell them your name and address and the serial number of your Product. They will tell you how to get a part replaced, or if necessary, arrange for service where your Product is located or advise you how to ship the Product for service. Before shipping, always obtain a Return Authorization Number (RA No.) from our Customer Service Department; securely pack your Product (save the original shipping carton if possible); put the RA No. on the outside of the carton and insure the product. Include a letter explaining the product or problem and a copy of your proof of purchase if you believe the service is covered by warranty.

ICON is not responsible or liable for indirect, special or consequential damages arising out of or in connection with the use or performance of the product or damages with respect to any economic loss, loss of property, loss of revenues or profits, loss of enjoyment or use, costs of removal, installation or other consequential damages of whatsoever nature. Some states do not allow the exclusion or limitation of incidental or consequential damages. Accordingly, the above limitation may not apply to you.

The warranty extended hereunder is in lieu of any and all other warranties and any implied warranties of merchantability or fitness for a particular purpose is limited in its scope and duration to the terms set forth herein. Some states do not allow limitations on how long an implied warranty lasts. Accordingly, the above limitation may not apply to you.

No one is authorized to change, modify or extend the terms of this limited warranty. This warranty gives you specific legal rights and you may have other rights which vary from state to state.

**ICON HEALTH & FITNESS, INC., 1500 S. 1000 W., LOGAN, UT 84321-9813**