



Salamangril®

OWNER'S MANUAL



MODELS TESG-24L
 TESG-24N

TWIN EAGLES, INC.
13231 East 166th St.
Cerritos, California 90703
1(800) 789-2206
www.twineaglesbbq.com

**NEED ASSISTANCE? PLEASE CALL:
(800) 789-2206**

FOR YOUR RECORDS

Please record the following information and refer to them when contacting the company or an authorized service agent. This information is found on the data plate, located at the back panel.

Model Number: _____

Serial Number: _____

Date of Purchase: _____

Place of Purchase: _____

Type of Gas: NG LP

FOR YOUR SAFETY

If you smell gas:

1. Shut off gas to the grill.
2. Extinguish any open flame.
3. If odor continues, immediately call your gas supplier or fire department.

FOR YOUR SAFETY

1. Do not store or use gasoline or other flammable vapors and liquid in the vicinity of this or any other appliance.
2. An LP (Liquefied Propane) cylinder not connected for use shall not be stored in the vicinity of this or any other appliance.



TABLE OF CONTENTS – Salamangrill

For Your Records...For You Safety.....	1
Table of Contents.....	2
IMPORTANT SAFETY INFORMATION	
General Safety Requirements.....	3
Safety Precautions on Pizza Stone.....	3
GAS REQUIREMENTS	
Liquefied Petroleum Connection & LP Gas Safety Information.....	4
Natural Gas Connection & NG Safety Information.....	4
INSTALLATION INSTRUCTIONS	
LP & NG Hook-up.....	5
Required Combustible Clearance Dimensions.....	5
BASIC ASSEMBLY INSTRUCTIONS	
Stopper Tab.....	6
Grease Drip Pan.....	6
SS Front Cover.....	6
Vinyl Cover.....	6
OPERATING INSTRUCTIONS	
General Operating Instructions.....	7
Battery Replacement.....	7
COOKING TIPS.....	8
CLEANING AND MAINTENANCE	
Stainless Steel.....	9
Mild Steel.....	9
Grill Rack.....	9
Slide Drip Pan.....	9
Pizza Stone.....	9
Infrared Burner.....	10
PARTS LIST	
Parts List.....	11
TROUBLESHOOTING GUIDE.....	12
WARRANTY.....	13
WARRANTY REGISTRATION.....	A

SAVE THIS MANUAL FOR FUTURE REFERENCE



IMPORTANT SAFETY INFORMATION – *Salamangrill*

IMPORTANT: PLEASE READ MANUAL CAREFULLY BEFORE USING YOUR *Salamangrill* TO ENSURE PROPER OPERATION AND TO REDUCE THE RISK OF FIRE, BURN HAZARD AND OTHER INJURY.

General Safety Requirements:

1. Do NOT operate any appliance with damages and do NOT try repairing or replacing any internal parts. Call the TWIN EAGLES customer service department at (800) 789-2206 for examination, repair or adjustments. Parts replaceable by consumer are parts listed on this manual ONLY.
2. The installation of this appliance must conform with local codes or in the absence of local codes installation must comply with either the National Fuel Gas Code, ANZI Z223.1/NFPA 54 or CAN/CGA-B149.1, Natural Gas Installation Code or CAN/CGA-B149.2, *Propane Installation Code*.
3. This outdoor cooking gas appliance is NOT intended to be installed in or on boats. It is also NOT intended to be used in the interior living space of a recreational vehicle. It can only be used outside of the RV while being hooked up to the RV's propane system.
4. This outdoor cooking gas appliance is intended for outdoor use ONLY and shall NOT be used in a building, garage or any other enclosed area.
5. Minimum clearance of **12 inches** from the back, **18 inches** from the top and **6 inches** from the sides of the *Salamangrill* to adjacent combustible construction must be maintained.
6. Do NOT use this unit for other than its intended use.
7. Keep your *Salamangrill* in an area clear and free from combustible materials, gasoline and other flammable vapors and liquids.
8. DO NOT obstruct the flow of combustion and ventilation air to this appliance.
9. Check all gas connections for leaks with soapy water solution. Never use an open flame to test for a gas leak. Also inspect the gas hose for any wear or cut, if found it must be replaced prior to operating the grill.
10. Never use the *Salamangrill* in a windy area. Keep it away from water sprinklers and rainfall.
11. The use of accessories not included or recommended by the appliance manufacturer may cause damages, injuries and/ or other serious problems.
12. Never use the *Salamangrill* without the grease slide pan & drip pans installed. Without these pans, hot grease and debris could leak downward and produce a fire hazard.
13. The pressure regulator and hose assembly supplied with the *Salamangrill* must be used. Replacement pressure regulators and hose assemblies must be those specified by Twin Eagles listed on page 11.
14. **CALIFORNIA PROPOSITION 65-WARNING:** The burning of gas cooking fuel generates some by-products which are on the list of substances known by the State of California to cause cancer or reproductive harm. California law requires businesses to warn customers of potential exposure to such substances. To minimize exposure to these substances always operate this unit according to the owner's manual, ensuring you provide good ventilation when cooking with gas.
15. Do NOT place plastic wrapped foods or containers in the *Salamangrill* at any time, plastic can melt and cause serious problems.

SAFETY PRECAUTIONS ON THE PIZZA STONE

1. Use only the Salamangrill® pizza stone provided. Other pizza stones will break under direct heat source.
2. Always follow the enclosed Manufacturer's Owner's Manual.



GAS REQUIREMENTS – *Salamangrill*

Each *Salamangrill* is set and tested at the factory for the type of gas supply intended to be used. Identify the type of gas on the rating plate located at the rear of the unit. It should either be Natural Gas (NG) or Propane/Liquefied Petroleum (LP) gas. Use only the gas stated on the rating plate. A gas conversion kit is available for the *Salamangrill* (LP-to-NG/ NG-to-LP) with instructions on how to do it.

➤ **PROPANE/ LIQUEFIED PETROLEUM (LP)**

If your *Salamangrill* is factory built for LP, the regulator supplied is set for 10” water column and is only to be used on an LP gas cylinder (5 gallon 20 lb.) along with the supplied gas hose.

- ✓ **Safety Requirement for LP Cylinder; NEVER USE A RUSTY or DENTED LP CYLINDER or A CYLINDER WITH A DAMAGED VALVE.** The LP-gas supply cylinder must be constructed and marked in accordance with the Specifications for LP-gas Cylinders of the U.S. Department of Transportation (D.O.T.) or the National Standards of Canada CAN/CSA-B339, Cylinders, Spheres and Tubes for the Transportation of Dangerous Goods, and Commission.
- ✓ **Safety Requirement for LP Plumbed-In;** the installation must conform to all local codes and CAN/CGA-B149.2, Propane Installation Code.

➤ **NATURAL GAS (NG)**

If your *Salamangrill* is factory built for natural gas, the regulator supplied is set for 4” water column and can be verified by removing the brass hex cap. You will find the conversion plastic pin attached to the cap to the underside of the cap. If the disc (1/2 in. diameter) of the pin is close to the cap, then the regulator is set for natural gas. If the disc is at the tip of the pin, away from the brass cap, the regulator is set for system LP application.

- ✓ **Safety Requirement for NG;** The installation must conform with local codes or, in the absence of local codes, with either the national Fuel Gas Code, ANSI Z223.1/NFPA 54, or CAN/CGA-B149.1, Natural Gas Installation Code.

**NEED ASSISTANCE? PLEASE CALL:
(800) 789-2206**



INSTALLATION INSTRUCTIONS – Salamangrill

Typical LP Gas Hook-up

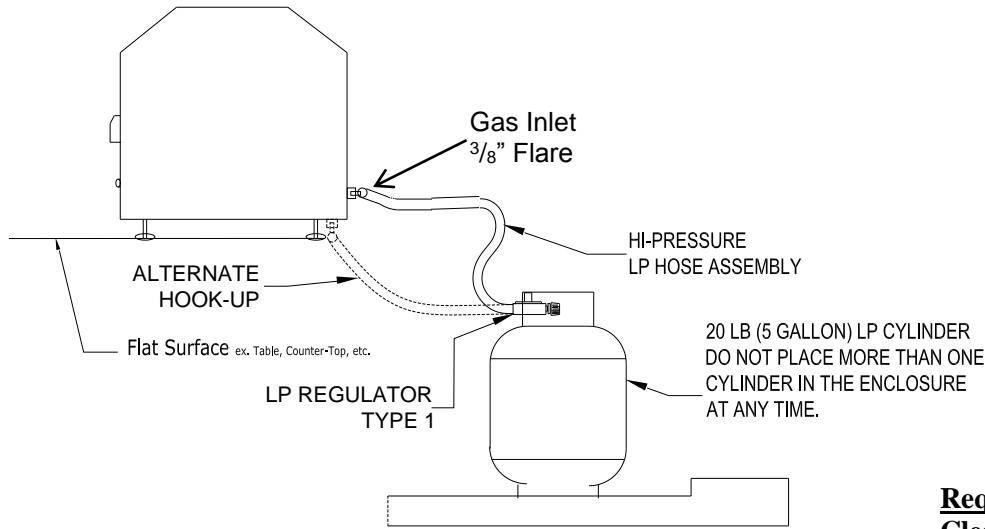

Required Combustible Clearance Dimensions

NOTE: When choosing a location for your *Salamangrill*, keep in mind that minimum clearances must be maintained to adjacent combustible construction;

TOP: 18 inches to any...

REAR: 12 inches to any...

SIDES: 6 inches to any...

...adjacent combustible construction.

Typical Natural Gas Hook-up

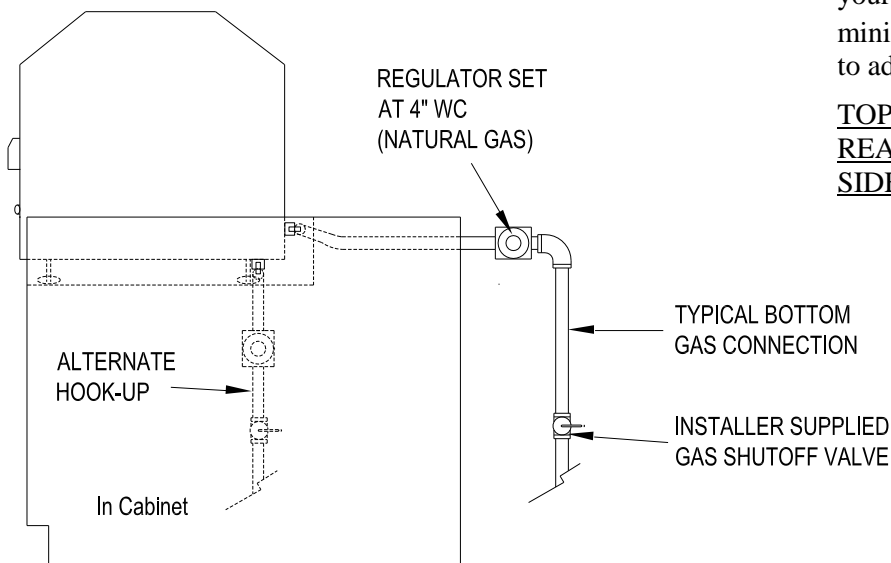

⚠ WARNING

Products, including cleaning solutions such as Chlorine, Solder fluxes and other caustic chemicals ARE NOT TO BE STORED INSIDE THE BASE CART OR NEAR THE CONNECTORS. If the SS flex hose or connectors comes in contact with any of this chemicals they **MUST** be washed off immediately with water to prevent pinholes &/ or corrosion.



BASIC ASSEMBLY INSTRUCTIONS – Salamangrill

1) **STOPPER TAB:** When you slide out the cooking rack from the handle it should have a stopping point. If it doesn't STOP, push the tab down. If the cooking rack needs to be removed for maintenance, give it a good pull and it will slide off.

2) **GREASE DRIP PAN:** The Grease Drip Pan can be removed from the cooking rack by pulling the drip pan UP and pushing the cooking rack DOWN with both hands. You will hear a "Snap" when it comes off. To place back on, do the opposite. Grease Drip Pan & Cooking Rack assembly is to be inserted as shown on picture (2.1).

3) **SS FRONT COVER: CAUTION!** DO NOT use the front cover while the burner is on or while cooking. To install, cover as shown. Stainless Steel cover is strictly used to keep dust, debris from cooking area only.

4) **VINYL COVER:** Place the vinyl cover only when the grill has cooled down to room temperature. The vinyl cover will help maintain your Salamangrill clean from outdoor exposure.

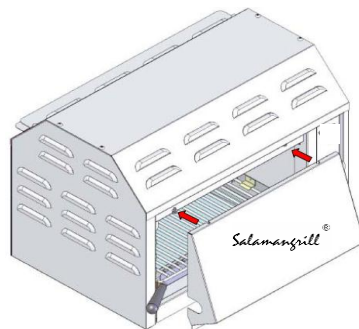
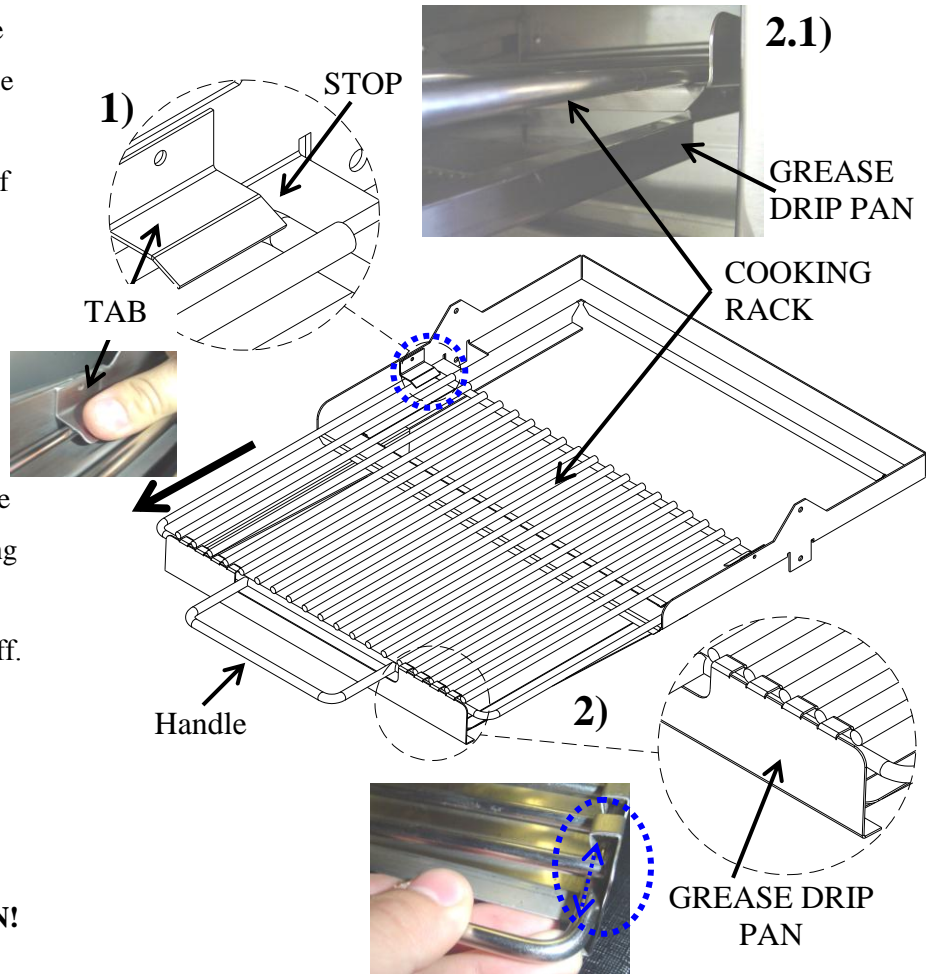

4)



OPERATING INSTRUCTIONS – Salamangrill

NOTE:

- a) Before operating the unit, make sure that all requirements specified by this Owner's Manual have been previously performed.
 - b) Cold start ignition may require multiple attempts for Infrared Burner to ignite. This is normal with infrared burners especially when an LP tank is installed for the first time since air could be trapped in the flex hose.
1. Remove the vinyl cover and Stainless Steel front cover if installed.
 2. Before lighting, make sure the grill is free of clutter & no cooking utensils are inside. Both grease drip pans and the bottom drip pan are to be installed before cooking.
 3. Make sure the knob is in the "OFF" position and make sure that the drip pans are properly installed.
 4. Turn "ON" the gas at source. **CAUTION:** If you smell gas, shut off gas supply and call for service.
 5. Push and turn the burner knob counterclockwise to "HI" (large flame) position.
 6. Push and hold the igniter button. You should hear a continuous clicking sound while sparks being provided to the burner. (If clicking sound is weak, battery must be replaced).



Replacing the Battery:

1. Unscrew the ignition button and remove the old battery.
2. Replace with a new AAA battery. (1.5V).
3. Screw on the ignition button back on.



7. If the IR burner does not ignite within 5 seconds, turn the IR burner to "OFF" and wait for five minutes and repeat steps 4-6 on this procedure.
8. The IR burner color will be blue at initial start. Within 2 minutes, the burner will start glowing red. After pre-heating the grill for 5 minutes to allow cooking rack to heat up, you are now ready to start grilling your steak, chicken or fish, melt cheese or cook your own pizza. The rack has 4 pre-set positions: the highest level being the hottest since its closer to the burner.
9. To shutdown the IR burner, push and turn the burner knob clockwise to "OFF".
10. For complete shutdown, turn "OFF" the gas at the main source.

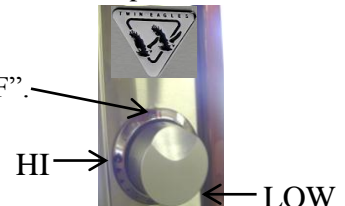

CAUTION

Do not use the front cover while the burner is ON or while cooking.

Do not leave the grill unattended. Close supervision is necessary while cooking especially when children are present.

Always wear protective insulated oven mitts when touching the –Salamangrill, pizza stone, hot dishes, drip pans and food when inserting or removing them from inside the grill. Do not touch any hot components while the unit is in operation or has not yet cooled down to room temperature because Grill surfaces and components are hot during and after use.



COOKING TIPS – Salamangrill



Burgers

Cook at High Temperature with the carriage at the highest setting.

Cook a 1-inch thick, 8-ounce burger for 3-1/2 minutes each side.

Steaks

Cook at High Temperature with the carriage at the highest setting.

Cook a 1-1/2 inch steak for 3 minutes on each side for medium rare steak.

Chicken

Chicken Breast, boneless and skinless: Cook at Medium High Heat with the carriage at the 2nd setting from top.

Cook approximately 3 to 4 minutes each side.

Chicken pieces, Medium Heat: Cook at Medium Heat with the carriage 3rd setting from top.

Cook turning occasionally for 25 to 30 minutes.

Seafood

Cook at High Temperature with the carriage at the 2nd setting from the top.

Cook salmon, swordfish or any firm flesh fish for 3 minutes on each side.



Pizza

Do not use frozen pizza. Only defrosted pizzas.

Never soak the pizza stone in any liquid.

Heat stone on carriage set at Medium High Heat with the carriage at the highest setting for 5 to 7 minutes.

Lower carriage to lowest setting.

Cook thin crust pizza on stone until cheese bubbles and crust is golden brown or in approximately 4 minutes.

Rotate pizza 180° once for even cooking from front to back.



CLEANING AND MAINTENANCE – *Salamangrill*

In order to maintain your *Salamangrill* in its original fine quality appearance, we recommend that you follow these directions carefully to maximize its performance and longevity. The frequency of usage and amounts of foods cooked will determine how often you should clean your grill. Clean the entire grill at least once a year, reference the safety instructions. Damaged caused by failure to follow these steps is not covered by the warranty.

TO CLEAN:

➤ STAINLESS STEEL:

Slight discoloration may occur at the rear area.

- a) The interior of the *Salamangrill* is made of #304 stainless steel. It is non-rusting and non-magnetic.
- b) Never clean the stainless steel surface when it is hot. After the initial grilling use, certain areas of the appliance may discolor. This is a normal discoloration caused by the intense heat given off by the Infrared burners.
- c) Specks of grease can gather on the surface of the stainless steel and get baked-on. These can be removed by using a mild abrasive pad (like Scotch Brite) with a stainless steel cleaner. Use the mildest cleaner and always scrub in the direction of the grain.
- d) Do NOT use steel wool to clean the appliance.
- e) To touch-up minor scratches in the stainless steel, sand the affected surface very lightly, with 100-dry grit emery sandpaper in the direction of the grain.

➤ MILD STEEL:

It is common to have minor color variations on the painted surface due to the nature of the coating.

The exterior of the *Salamangrill* is made of mild steel coated with powder paint and cured in an oven for durability.

- a) DO NOT clean while it's hot.
- b) DO NOT use steel wool or abrasive to clean the exterior or it will scratch the paint. Use water and liquid soap to remove dirt and grease. Then wipe surface dry with paper towel or cloth.

➤ GRILL RACK:

- a) Allow all components to cool down before cleaning or removing them.
- b) Wear a barbecue mitt to protect your hands from the heat and steam. Dip a brass bristle barbecue brush in tap water and scrub the grill rack. These food particles will fall into the drip pans.
- c) Remove the grill rack from the carriage.

➤ SLIDE/ DRIP PAN:

- a) The slide pan collects grease drippings, liquids and food particles and directs them to the drip pan.
- b) Allow the pan and its contents to cool before cleaning. Slide the pan out and wipe it clean. Make sure the pan is fully inserted back to its tray before using the *Salamangrill*®.
- c) It is highly recommended to clean the grease drip pan and the bottom drip pan after every use to avoid any possibility of a grease fire.

➤ PIZZA STONE:

Do not use other pizza stones only the *Salamangrill* pizza stone provided. Other pizza stones could break during use because they are not designed to be used for the *Salamangrill*. Always follow the enclosed Manufacturer's Use and Care Manual.

- 1) To clean your pizza stone, simply scrape off any baked-on food with a plastic scraper. You may also scour the surface with baking soda, using a plastic scouring pad or a stiff bristled brush. Sponge, using clear warm running water. Detergent or soapy water is not recommended. Air dry.
- 2) Do not clean it in a dishwasher.
- 3) Always let the pizza stone cool before placing under running water. Soaking is not recommended.

CONTINUE ON NEXT PAGE



- 4) Dropping the pizza stone may cause it to crack or break. Never use a cracked or broken pizza stone.
- 5) Always use a padded oven mitt when handling a heated pizza stone.
- 6) Do not put a wet pizza stone into a heated *Salamangrill* as this may cause cracking. Thermal shock, or a sudden change in temperature, can also cause the stones to crack, so a cold stone should not be placed in the hot *Salamangrill*. Instead, place the cool pizza stone in the lowest rack, then heat up the grill.
- 7) This pizza stone is an unglazed porous plate and can absorb cooking oils or other ingredients of a liquid nature: it is for this reason that we recommend that you only use the pizza stone for making pizza and other non-oily products. Recipes that require oils, butter, margarine or lard, are not recommended for use with this pizza stone.
- 8) This pizza stone can be cleaned periodically by placing the plate at the lower rack position and setting the grill on HI for 30 minutes. Then after the plate is cooled, you may scrape it with a plastic spatula and scour it with baking soda using a plastic scouring pad or a stiff bristle non-metallic brush to remove any surface residue. This process will help remove any residue and will freshen up the plate.
- 9) Staining is a natural part of aging of the pizza stone.

INFRARED BURNER:

- a) Do NOT clean the infrared burner. This may result in breakage.
- b) Do NOT use any type of cleaning solution on the infrared. Do NOT try to scrub the infrared burner or use a wet sponge.
- c) Never allow direct impact to the ceramic with hard objects.



REPLACEMENT PARTS LIST – *Salamangrill*

Item Number	Part Number	Part Description	Qty
1	S16115	IGNITER ELECTRODE	1
2	S16168	IGNITER WIRE	1
3	S20730Y	CARRIAGE ASSEMBLY	1
4	S13848	HANDLE, PHENOLIC	1
5	S14190	HANDLE BOLT	1
6	S13846	COOKING RACK	1
7	S20735	SLIDE PAN ASSEMBLY	1
8	S20714	DRIP PAN	1
9	S14420	ROLLER	2
10	S13101	KNOB	1
11	S13128P	BEZEL	1
12	S15106	VALVE	1
13	S16157	IGNITION MODULE	1
14	S13112	Twin Eagles LOGO	1
15	S14425	LEVELING MOUNT	4
16	S15344	LP REGULATOR (Model: TEGS-24L Only)	1
17	S15303	NG REGULATOR (Model: TEGS-24N Only)	1
18	S15325	HOSE w/ FITTINGS for NG	1
19	S14191	SPRING	1
20	S15108-57	LP ORIFICE # 57 DMS (Model: TEGS-24L Only)	1
21	S15108-50	NG ORIFICE # 50 DMS (Model: TEGS-24N Only)	1
22	S13344	INFRARED BURNER	1
23	S13138	PIZZA STONE	1
24	S20755	STAINLESS STEEL FRONT COVER	1
25	S13849	VINYL COVER, <i>Salamangrill</i>	1

For ordering parts, REFERENCE the front cover page for manufacture's contact information.

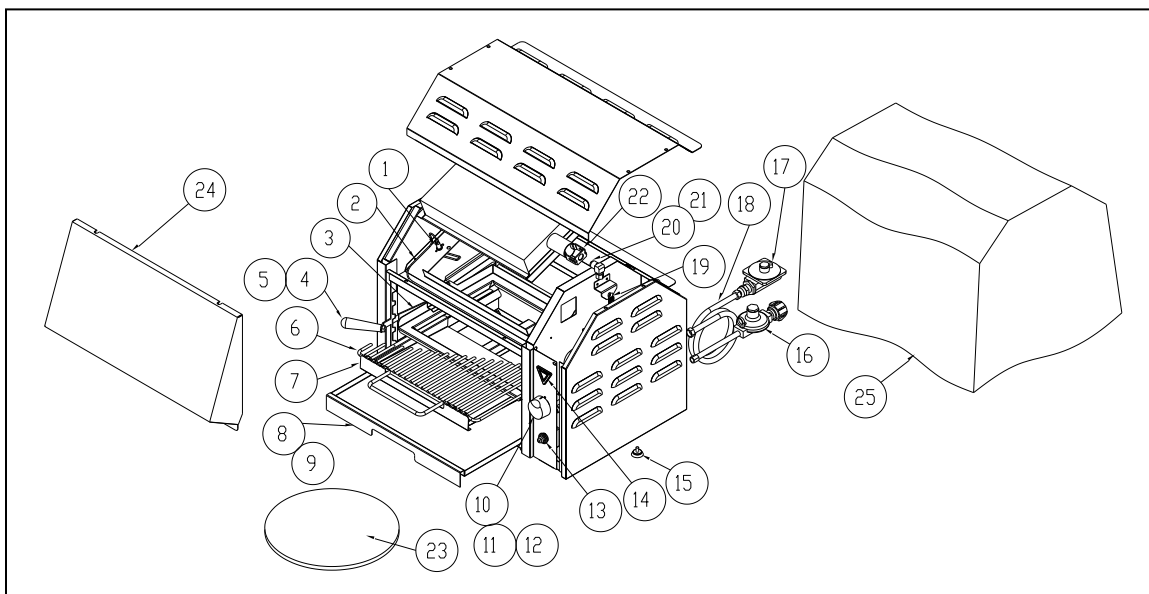

TROUBLESHOOTING GUIDE – *Salamangrill*

PROBLEM	WHAT TO DO
Grill will not fire-up	<p>1) Push the igniter button and check for sparks. If no sparks or sparks are weak, replace the battery.</p> <p>2) If there is a spark, check if gas is supplied to the burner.</p> <p style="padding-left: 20px;">a) Visually check the electrode and wire while pushing the igniter button. If a spark occurs anywhere but the igniter tip, the igniter wire or igniter electrode must be replaced.</p> <p>NOTE:</p> <p style="padding-left: 20px;">I. Cold start ignition may require multiple attempts for Infrared Burner to ignite. This is normal with infrared burners especially when an LP tank is installed for the first time since air could be trapped in the flex hose.</p> <p style="padding-left: 20px;">II. It is normal to hear a popping sound when the IR grill burner is first turned ON.</p>
Low heat generated with knob in HI-setting	<p>1) Check for any bent or kinked fuel hose.</p> <p>2) Check for proper gas supply and pressure.</p> <p>3) Pre-heat grill for 2-3 minutes or until the IR burner glows red.</p>
IR Burner Extinguishes	<p>1) Check for any burner defect</p> <p>2) Check if gas supply is sufficient</p> <p>3) Check if LP tank is empty</p> <p>4) You might need to adjust the valve by turning the bypass screw clockwise which is located in the valve and you can have access to it by removing the knob.</p>

**NEED ASSISTANCE? PLEASE CALL:
(800) 422-0091**



TWIN EAGLES – *Salamangrill*

Limited Product Warranty

Model: _____

Serial No: _____

Date of Purchase: _____

Retailer: _____

Thank you very much for purchasing a high quality grill from Twin Eagles. We have designed this grill to provide you and your family with many years of great outdoor cooking experiences. Please fill in the Model and Serial number as well as date of purchase in the areas indicated above. Please save this information for future reference. To get the full and safe enjoyment for your grill please read your Owner's Manual carefully and review the proper operating and safety instructions with any family members that may be using the grill.

Manufacturer Warranty: *Twin Eagles* warrants that this grill is designed and manufactured to be free from defects in materials and workmanship for a period of one year from original date of purchase.

Extent of Warranty: This warranty shall apply only to the products delivered in the continental United States and Canada. It extends to the selling dealers to the original purchaser at the original site of installation: This warranty becomes valid at the time of purchase and ends either by specified timeframe listed above, owner transfer or relocation. *In order to activate the warranty we require that you send in the attached warranty registration card. This registration is for our internal use only and will only be used in the event we need to send you important safety related product information. The information will not be sold or used for any marketing related purposes.*

Warranty Performance: In the event of malfunction or defect covered under the terms of this warranty, the factory authorized selling dealer and or **authorized distributor** is responsible for performing all necessary repairs. To obtain service, contact the nearest authorized retailer. In the event the consumer is unable to obtain satisfactory customer service from the authorized dealer, please call us directly at **(800) 789-2206**. We may require that a written notification be submitted to Twin Eagles Customer Service Department within ten (10) days of the reported failure. *There will be no charge for parts if they are covered under our warranty.*

In the event of any warranty replacement, all removal, replacement, installation and shipping costs are the responsibility of the grill owner. *All field service costs are not covered in any way by this warranty.* If *Twin Eagles* determines that repair of a covered item is not feasible, *Twin Eagles* reserves the right to replace the defective merchandise.

Warranty Limitations and Exclusions: This warranty does not apply to damages resulting from negligence, alteration, misuse, abuse, accident, natural disaster, improper installation or improper operation, unauthorized adjustments or calibrations, dings, dents, scratches, nor damages due to harsh chemicals (i.e. cleaning products improperly applied). Warrantor is not responsible for consequential or incidental damages. Under no circumstances shall *Twin Eagles* or any of its representatives be held liable for injury to any person or damage to any property, however arising. *This warranty does not apply to commercial use, or to products with altered or removed serial numbers.*

Important: Please retain original proof of purchase to establish warranty period.

Any implied warranties of merchantability and fitness applicable to the equipment are limited in duration to the period of coverage of this express written warranty. This warranty grants specific legal rights to the purchaser. Other rights, which may vary from state to state, may also apply. Title to the merchandise passes to the consignee upon acceptance by the carrier. After acceptance by the carrier, the merchandise travels at the risk of the purchaser. In the event of freight damage, do not refuse shipment. Advise both the freight agent and the shipper of the damage. Note the details of that damage on the freight bill before any freight charges are paid and file a claim for damages with the freight agent.

TWIN EAGLES Products-Crafted With Pride in the USA



Place
Postage
Here



Customer Service
ATTN: Warranty Department
13231 East 166th Street
Cerritos, CA 90703
Fax no. (562) 802-3391

Fold Here



Warranty Registration

Customer Name

Model #

Address

Serial #

City

Date Purchased

Zip

Dealer's Name

Phone #

Dealer's Address

e-mail:

This Warranty Registration card must be returned within thirty days of purchased to properly activate your warranty.

This information is for our internal use only.

Or you may register online at <http://www.twineaglesbbq.com/contactus.shtml>



A