

ASR1100 Rotary Stage

User's Manual

P/N: EDS131 (Revision 1.02.00)



Dedicated to the Science of Motion
Aerotech, Inc.
101 Zeta Drive,
Pittsburgh, PA, 15238
Phone: 412-963-7470
Fax: 412-963-7459
www.aerotech.com



Product Registration

Register online at: <http://www.aerotech.com/prodreg.cfm>

Technical Support

United States Headquarters:

Phone: (412) 967-6440

Fax: (412) 967-6870

Email: service@aerotech.com

United Kingdom:

Phone: +44 118 940 9400

Fax: +44 118 940 9401

Email: service@aerotech.co.uk

Germany:

Phone: +49 911 967 9370

Fax: +49 911 967 93720

Email: service@aerotechgmbh.de

Japan:

Phone: +81(0)47-489-1741 (Sales)

Phone: +81(0)47-489-1742 (Service)

Fax: +81(0)47-489-1743

Email: service@aerotechkk.com.jp

China:

Phone: +852-3793-3488

Email: saleschina@aerotech.com

Revision History

Revision 1.02.00	February 21, 2011
Revision 1.01.00	August 16, 2010
Revision 1.00.00	August 28, 2008

Table of Contents

Table of Contents.....	iii
List of Figures.....	v
List of Tables.....	vii
Chapter 1: Overview.....	1
1.1. Standard Features.....	2
1.1.1. Rotary Axis.....	2
1.2. Optional Features.....	3
1.2.1. Mounting Plate.....	3
1.2.2. Wrenches.....	3
1.2.3. Electronics Controller.....	3
1.3. Model Numbers.....	4
1.4. Dimensions.....	5
1.5. Safety Procedures and Warnings.....	6
1.6. EC Declaration of Incorporation.....	8
Chapter 2: Installation.....	9
2.1. Unpacking and Handling the Stage.....	9
2.2. Preparing the Mounting Surface.....	10
2.3. Securing the Stage to the Mounting Surface.....	11
2.4. Attaching the Payload to the Stage.....	12
2.5. Changing ASR Workholding Devices.....	13
2.5.1. Collet Installation and Removal Procedure.....	13
2.6. Electrical Installation.....	16
2.7. Air Requirements.....	16
Chapter 3: Operating Specifications.....	17
3.1. Environmental Specifications.....	17
3.2. Accuracy and Temperature Effects.....	17
3.3. Basic Specifications.....	18
3.4. Load Capability.....	19
Chapter 4: Maintenance.....	21
4.1. Service and Inspection Schedule.....	21
4.2. Cleaning and Lubrication.....	22
4.2.1. Collet & Collet Chuck Lubrication and Cleaning.....	22
4.3. Seal Replacement.....	23
4.3.1. Piston Seal Change Procedure.....	23
Appendix A: Warranty and Field Service.....	25
Appendix B: Technical Changes.....	27
Index.....	29
Reader's Comments.....	31

List of Figures

Figure 1-1: ASR1100 Rotary Stage.....	1
Figure 1-2: ASR1100 Dimensions.....	5
Figure 2-1: ASR1100 Stage Showing Mounting Plate (Top View).....	11
Figure 2-2: ASR1100 Stage Without Mounting Plate (Bottom View).....	11
Figure 2-3: Installation of Collet into Collet Nut.....	14
Figure 2-4: Installation Procedure for Collet/Collet Nut.....	15

List of Tables

Table 1-1: Model Numbering System	4
Table 3-1: Environmental Specifications.....	17
Table 3-2: ASR1100 Series Specifications.....	18
Table 3-3: ASR1100 Motor Specifications.....	19
Table 4-1: Recommended Lubricants.....	22
Table B-1: Current Changes (1.02.00).....	27
Table B-2: Archived Changes.....	28

Chapter 1: Overview

Aerotech's ASR1100 mechanical-bearing rotary stage is a system that combines high precision rotary positioning with an integrated pneumatically controlled collet chuck for material handling. The ASR1100 series utilizes direct-drive brushless motor technology to maximize positioning performance and virtually eliminate the need for maintenance. These features make the ASR1100 an ideal choice for applications where low maintenance, high throughput, and low total cost of ownership are essential.

The ASR1100 has been designed with a collet chuck that can support ER16 collets (manufactured to DIN6499 specs) to allow for a wide range of materials and applications. This product is intended for light industrial manufacturing or laboratory use.

This chapter introduces standard and optional features of the ASR1100, explains the model numbering system, and gives general safety precautions. Figure 1-1 shows a typical ASR1100.

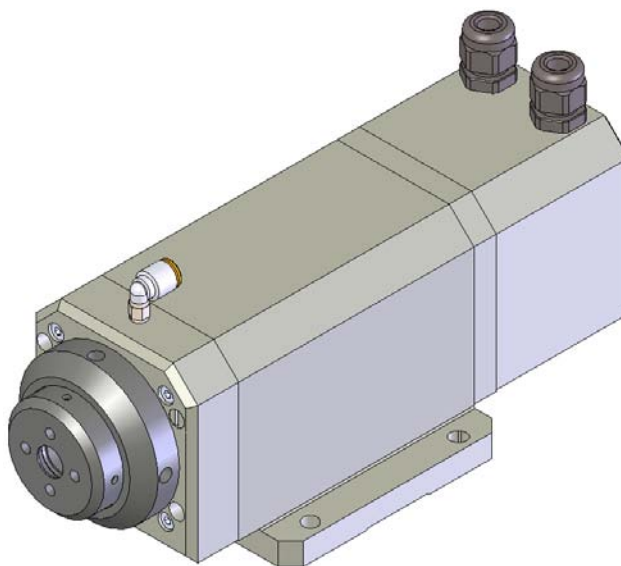

Figure 1-1: ASR1100 Rotary Stage

NOTE: Aerotech continually improves its product offerings, and listed options may be superseded at any time. Refer to the most recent edition of the Aerotech Motion Control Product Guide for the most current product information at www.aerotech.com.

NOTE: This manual should be read in its entirety before operating the ASR1100 system.

1.1. Standard Features

1.1.1. Rotary Axis

ASR1100 stages come standard with a direct drive brushless motor with a non-contacting integral rotary union. These features combine to create a low friction, low maintenance rotary stage capable of high accelerations and low positioning error. With a non-contact rotary union, there are no seals to be replaced or lubricated allowing for a lifetime of maintenance free performance. The brushless, slotless motor design allows for extremely high torque coupled with smooth motion. There are no brushes to wear, no belts to tension, and no gears to wear resulting in a completely maintenance-free motor.

The ASR1100 is designed with an ER16 style collet chuck. The maximum tube diameter supported by the ER16 collet chuck is 10 mm. The collet is retained with a threaded collet nut enabling quick changeover. It is configured in a “fail-safe” normally-closed mode where full clamping force is applied when no air pressure is present.

NOTE: Aerotech recommends using electro-polished collets manufactured to DIN6499 specs.

1.2. Optional Features

1.2.1. Mounting Plate

ASR1100 stages can be configured to include a mounting plate that can use either M6 or 1/4-20 bolts. The bottom of this mounting plate is precision machined and verified for flatness. If the mounting plate is not selected, a custom mounting option can be attached using the (Qty-4) M6 tapped holes in the bottom of the stage.

1.2.2. Wrenches

This option is selected when spanner wrenches for removing the collet nut are desired.

1.2.3. Electronics Controller

The ASR1100 stage is part of a complete Aerotech motion control system, which is adjusted at the factory for optimum performance. Setup involves connecting a stage to the appropriate drives with the cables provided. Refer to your electrical documentation package for further information.

1.3. Model Numbers

The stage model number indicates the optional features on a particular stage. To determine the options on your stage, refer to Table 1-1 for an explanation of the numbering system.

Example: ASR1100-10-HPD-NC-RE2048AS-S-MP-WRENCH

Table 1-1: Model Numbering System

ASR1100, Direct Drive Rotary Stage	
ASR1100	Direct drive rotary stage with integral ER-style collet chuck
Drive Motor	
-10	5 N-m peak, 1.95 N-m continuous direct-drive brushless motor
Connector	
-HPD	High power D connector for motor power and 25-pin D for feedback
-25D	Dual 25-pin D connectors with bridged pins for motor power
-MS	MS-style connectors for motor power and feedback
Collet Chuck	
-NC	Normally Closed Collet Chuck for ER16 Collet
Position Transducer	
-RE2048AS	Incremental encoder with 2048 cycles per rev sinusoidal output signal
-RE5000AS	Incremental encoder with 5000 cycles per rev sinusoidal output signal
Rear Seal	
-S	Rear shaft seal
-NS	No shaft seal
Options	
-MP	Mounting plate
-WRENCH	Spanner wrenches for changing ER16 collets

1.4. Dimensions

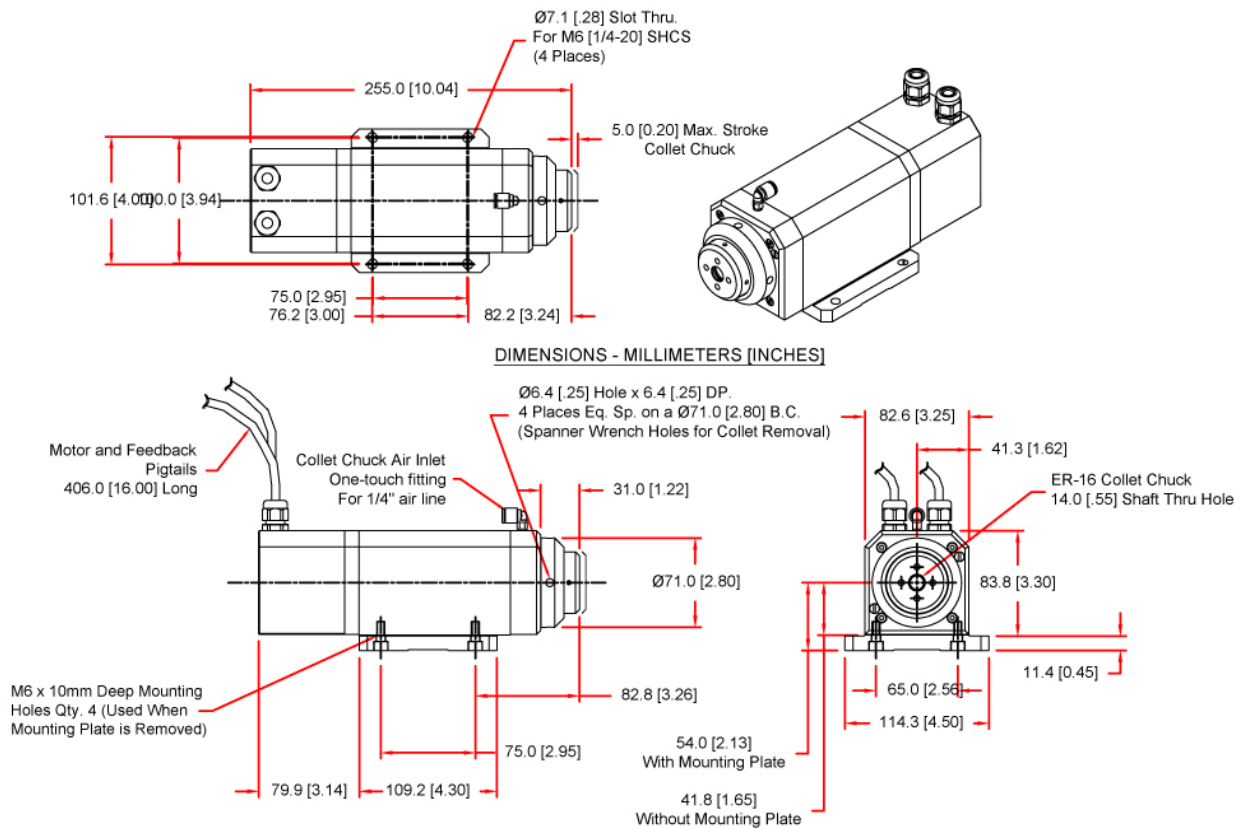

Figure 1-2: ASR1100 Dimensions

1.5. Safety Procedures and Warnings

The following statements apply throughout this manual. Failure to observe these precautions could result in serious injury to those performing the procedures and damage to the equipment.

This manual and any additional instructions included with the stage should be retained for the lifetime of the stage.



DANGER

To minimize the possibility of electrical shock and bodily injury or death, disconnect all electrical power prior to making any electrical connections.



DANGER

To minimize the possibility of electrical shock and bodily injury or death when any electrical circuit is in use, ensure that no person comes in contact with the circuitry when the stage is connected to a power source.



DANGER

To minimize the possibility of bodily injury or death, disconnect all electrical power prior to making any mechanical adjustments.



DANGER

Moving parts of the stage can cause crushing or shearing injuries. All personnel must remain clear of any moving parts.



WARNING

Improper use of the stage can cause damage, shock, injury, or death. Read and understand this manual before operating the stage.



WARNING

If the stage is used in a manner not specified by the manufacturer, the protection provided by the stage can be impaired.



WARNING

Stage cables can pose a tripping hazard. Securely mount and position all stage cables to avoid potential hazards.



WARNING

Do not expose the stage to environments or conditions outside the specified range of operating environments. Operation in conditions other than those specified can cause damage to the equipment.



WARNING

The stage must be mounted securely. Improper mounting can result in injury and damage to the equipment.



WARNING

Use care when moving the stage. Manually lifting or transporting stages can result in injury.



WARNING

Only trained personnel should operate, inspect, and maintain the stage.



WARNING

This stage is intended for light industrial manufacturing or laboratory use. Use of the stage for unintended applications can result in injury and damage to the equipment.



WARNING

Before using this stage, perform an operator risk assessment to determine the needed safety requirements.

1.6. EC Declaration of Incorporation

Manufacturer: Aerotech, Inc.
101 Zeta Drive
Pittsburgh, PA 15238
USA



herewith declares that the product:

Aerotech, Inc. ASR1100 Stage

is intended to be incorporated into machinery to constitute machinery covered by the Directive 2006/42/EC as amended;

does therefore not in every respect comply with the provisions of this directive;

and that the following harmonized European standards have been applied:

EN ISO 12100-1,-2:2003+A1:2009

Safety of machinery - Basic concepts, general principles for design

ISO 14121-1:2007

Safety of machinery - Risk assessment - Par 1: Principles

EN 60204-1:2005

Safety of machinery - Electrical equipment of machines - Part 1: General requirements

and further more declares that

it is not allowed to put the equipment into service until the machinery into which it is to be incorporated or of which it is to be a component has been found and declared to be in conformity with the provisions of the Directive 2006/42/EC and with national implementing legislation, i.e. as a whole, including the equipment referred to in this Declaration.

Authorized Representative: Manfred Besold
Address: AEROTECH GmbH
Süd-West-Park 90
D-90449 Nürnberg

Name:

Alex Weibel / 
Engineer Verifying Compliance

Position:

Location:

Pittsburgh, PA

Date:

February 21, 2011

Chapter 2: Installation

This chapter describes the installation procedure for the ASR1100 stage, including handling the stage properly, preparing the mounting surface to accept the stage, securing the stage to the mounting surface, attaching the payload, and making the electrical connections.



WARNING

Installation must follow the instructions in this chapter. Failure to follow these instructions could result in injury and damage to the equipment.

2.1. Unpacking and Handling the Stage

Carefully remove the stage from the protective shipping container. Use compressed nitrogen or clean, dry air to remove any dust or debris that has collected during shipping. *If any damage has occurred during shipping, report it immediately.*

Before operating the stage, it is important to let the stage stabilize at room temperature for at least 12 hours. Allowing the stage to stabilize to room temperature will ensure that all of the alignments, preloads, and tolerances are the same as they were when tested at Aerotech. Set the stage on a smooth, flat, and clean surface.

Each stage has a label listing the system part number and serial number. These numbers contain information necessary for maintaining or updating system hardware and software. Locate this label and record the information for later reference.



WARNING

Improper stage handling could adversely affect the stage's performance. Use care when moving the stage. Manually lifting or transporting the stage can result in injury



WARNING

Lift the stage only by the base. Do not use the ballscrew or motor as lifting points.

2.2. Preparing the Mounting Surface

The mounting surface should be flat and have adequate stiffness in order to achieve the maximum performance from the ASR1100 stage. When a stage is mounted to a non-flat surface, the stage can be distorted as the mounting screws are tightened. This distortion will decrease the overall accuracy of the stage. Adjustments to the mounting surface must be done before the stage is secured.

NOTE: To maintain accuracy, the mounting surface should be flat within 1 μm per 50 mm.

NOTE: The stage base is precision machined and verified for flatness prior to stage assembly at the factory. If machining is required to achieve the desired flatness, it should be performed on the mounting surface rather than the stage base. Shimming should be avoided if possible. If shimming is required, it should be minimized to improve the rigidity of the system.

2.3. Securing the Stage to the Mounting Surface

If a mounting plate is included on the stage, mount using (Qty-4) M6 or 1/4-20 bolts (refer to Figure 2-1). If the stage is configured without a mounting plate, use the (Qty-4) M6 tapped holes on the bottom of the stage to attach an alternative means of mounting (see Figure 2-2).



The stage must be mounted securely. Improper mounting can result in injury and damage to the equipment.

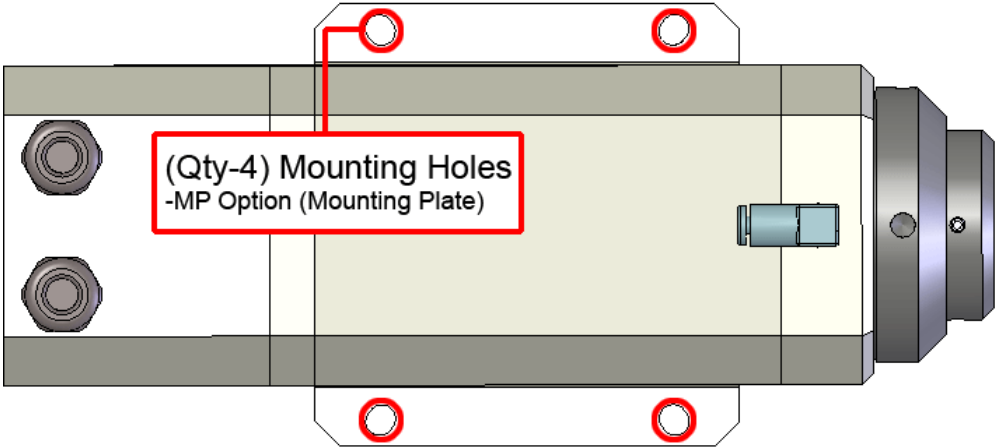

Figure 2-1: ASR1100 Stage Showing Mounting Plate (Top View)

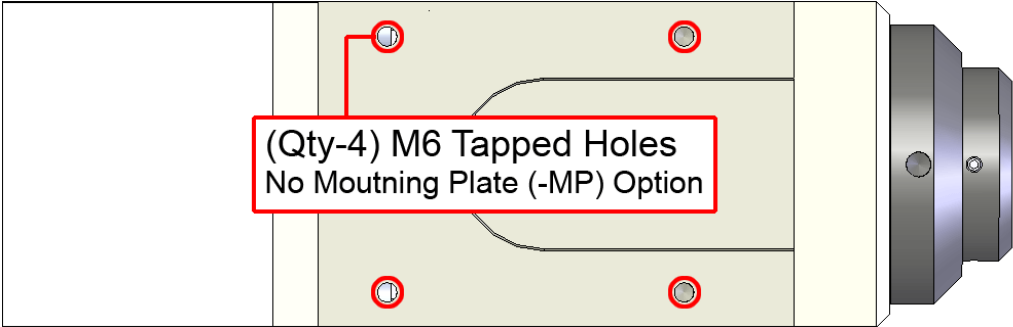

Figure 2-2: ASR1100 Stage Without Mounting Plate (Bottom View)

2.4. Attaching the Payload to the Stage

To prevent damage to the stage or parts, test the operation of the stage before any material is held in the collet. Proceed with the electrical installation and test the motion control system.

To operate the collet, clean compressed air or nitrogen must be supplied to the stage (see Section 2.7.). The one-touch air inlet fitting accepts 4 mm or 5/32" OD plastic air line.

Once air is supplied, material of the appropriate size can be placed in the collet. All collets supplied by Aero-tech are clearly labeled with their clamping size range and collet style. Be sure to use only the correct size material in the collet. If an incorrect material size is clamped, the accuracy of the collet could be compromised. Never clamp material or tools that are larger than the specified range. It is also important to have the material or tool inserted at least 2/3 the length of the collet bore. Any less than this could cause permanent deformation of the collet and reduce accuracy (see Section 2.5.1. for collet installation).

2.5. Changing ASR Workholding Devices

ASR1100 stages are equipped with an ER16 style collet. It is important that only the collets designed for a particular collet holder are used. Aerotech collet chucks are designed for use with ER collets manufactured to DIN6499 specifications. Aerotech recommends the use of ultra precision electroplated collets only. Contact the factory for more details.

NOTE: Various grip diameters are commonly available and can be interchanged following the collet removal and installation procedure detailed in Section 2.5.1.

2.5.1. Collet Installation and Removal Procedure



To minimize the possibility of bodily injury, confirm that all electrical power is disconnected prior to making any mechanical adjustments.

1. Before any collet change operation, remove power to the stage.
2. Apply air pressure to loosen the collet chuck.
3. Unscrew the collet nut. If necessary, use a spanner wrench (available from Aerotech).
4. For installation of a collet, first clean the collet housing, collet nut threads, collet nut, and new collet. Acetone or isopropyl alcohol may be used to clean the metal components. A small amount of any general-purpose, high viscosity grease can be applied to collet taper to help reduce friction and decrease wear.
5. Noting the orientation of the spot drill on the back side of the collet nut, refer to the instructions in Figure 2-3 to install the collet.
6. Guide the collet using the nut into the stage (Figure 2-4) making sure that the collet seats properly in its taper. Be sure that air pressure is still being supplied to the stage so the collet chuck is in the open position.
7. Tighten the collet nut. Tightening by hand is sufficient as the clamping force is not determined by the torque of the nut, but by the force of internal springs. Spanner wrenches may be used if desired.
8. Restore power to the stage.
9. For removal of a collet from the collet nut, apply pressure to the front of the collet while tilting it towards the spot drill.

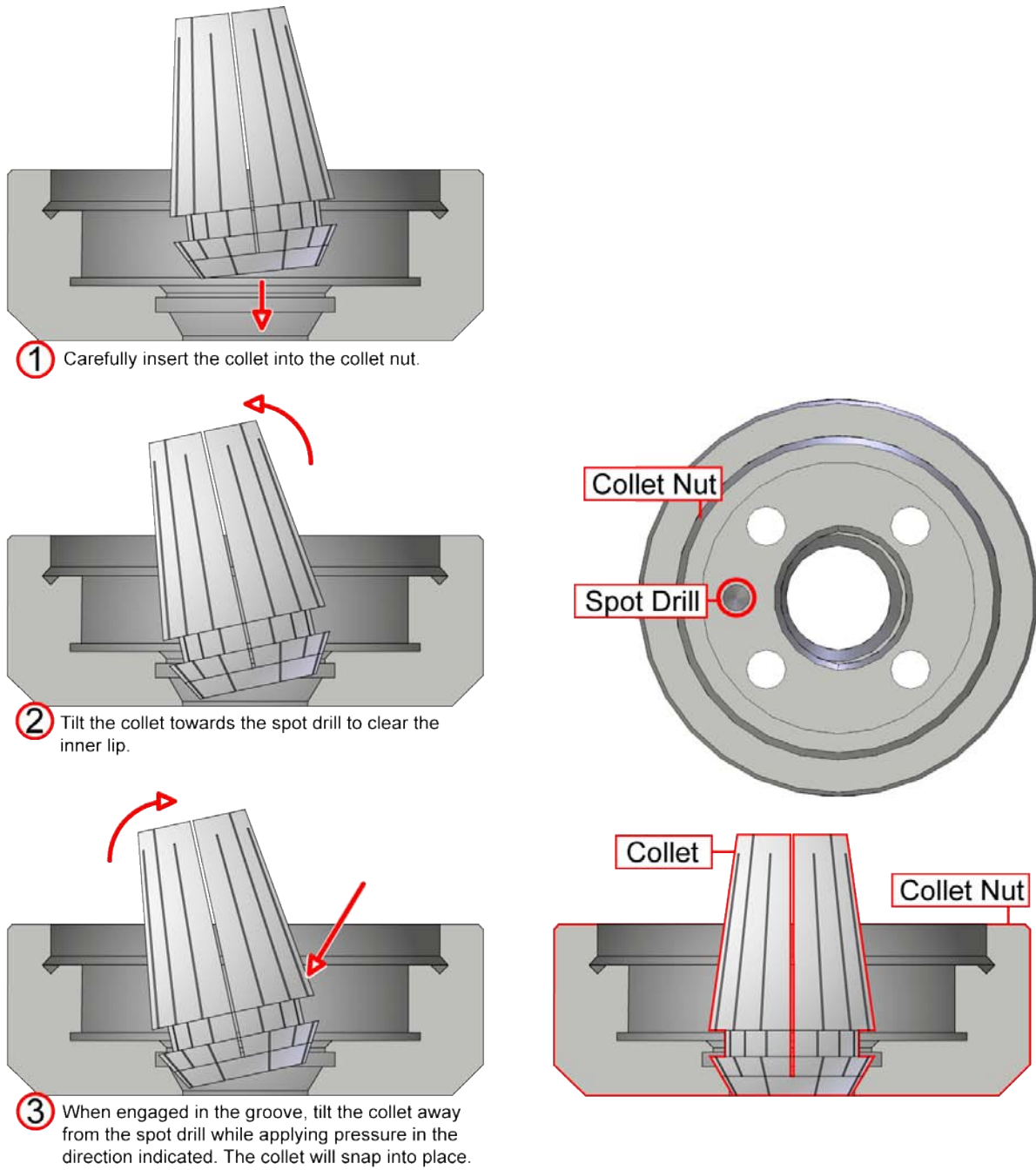

Figure 2-3: Installation of Collet into Collet Nut

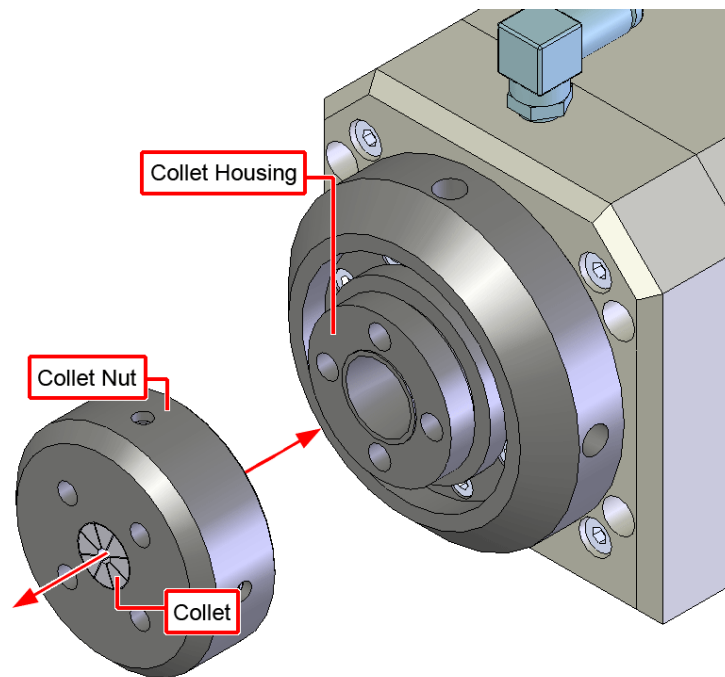

Figure 2-4: Installation Procedure for Collet/Collet Nut



WARNING

Do not install the collet into the taper and then thread the collet nut on. Damage to the collet and/or collet nut could result.

2.6. Electrical Installation

Aerotech motion control systems are adjusted at the factory for optimum performance. The ASR1100 series stage is part of a complete Aerotech motion control system. Setup involves connecting the stage and motor combination to the appropriate drive chassis with the cables provided. Connect the provided cables to the feedback and motor connectors on the stage.

Labels on the drive indicate the appropriate connections. Refer to your drive manuals and documentation for additional installation and operation information. In some cases, if the system is uniquely configured, a drawing showing system interconnects is supplied.



Never connect or disconnect any electrical component or connecting cable while power is applied, or serious damage may result.



Use only the cables provided by Aerotech as part of the complete motion control system.

2.7. Air Requirements

The air pressure supplied to the collet chuck is important in ensuring that the material or tool is released properly.

- If compressed air is used, it must be filtered to 0.25 microns, dry to 0° F dew point, and oil free.
- If nitrogen is used, it must be 99.99% pure and filtered to 0.25 microns.

The chuck becomes fully open at approximately 4-5.5 bar (60-80 psig) depending on the collet size. Higher pressures will not cause damage to the rotary union, but high flow rates will result. Because of the non-contact rotary union design on collet-equipped stages, a small amount of leakage will occur. Approximate leakage rates of between 10 Lpm (0.5 CFM) and 40 Lpm (1.4 CFM), depending on pressure, will be observed when the collet is open.

NOTE: When operating the ASR1100 it is recommended that 5 psi be supplied to the collet at all times. This will act as an air purge and help prevent contaminants from entering rotary union.

Chapter 3: Operating Specifications

The surrounding environment and operating conditions can affect the performance and service life of the stage. This chapter contains general technical information about the ASR1100 on ideal environmental, operating, and basic product specifications.

3.1. Environmental Specifications

The environmental specifications for the ASR1100 are listed in the following table.

Table 3-1: Environmental Specifications

Ambient Temperature	Operating: 16° to 25° C (61° to 77° F) The optimal operating temperature is 20° C \pm 2° C (68° F \pm 4° F). If at any time the operating temperature deviates from 20° C degradation in performance could occur. Contact Aerotech for information regarding your specific application and environment.
	Storage: 0° to 40° C (32° to 104° F) in original shipping packaging
Humidity	Operating: 40 percent to 60 percent RH The optimal operating humidity is 50 percent RH.
	Storage: 30 percent to 60 percent RH, non-condensing in original packaging
Altitude	Operating: 0 to 2,000 m (0 to 6,562 ft) above sea level Contact Aerotech if your specific application involves use above 2,000 m or below sea level.
Vibration	Use the system in a low vibration environment. Excessive floor or acoustical vibration can affect stage and system performance. Contact Aerotech for information regarding your specific application.
Dust Exposure	The ASR1100 stages have limited protection against dust, but not water. This equates to an ingress protection rating of IP50.
Use	Indoor use only



Do not expose the stage to environments or conditions outside the specified range of operating environments. Operation in conditions other than those specified can cause damage to the equipment.

3.2. Accuracy and Temperature Effects

Extreme temperature changes could cause a decrease in performance or permanent damage to the stage. Aerotech stages are designed for and built in a 20° C (68° F) environment.

3.3. Basic Specifications

ASR1100 stage specifications are shown in Table 3-2. Motor specifications are given in tab.

Table 3-2: ASR1100 Series Specifications

		Units	ASR1100
Rotary Travel		degrees	360° continuous
Maximum Speed		rpm	600
Collet Type ⁽¹⁾		n/a	ER16
Maximum Aperture (ER16)		mm	10
Accuracy		arc-sec	±15.0
Repeatability		arc-sec	±3.0
Inertia		kg-m ²	15 x 10 ⁻⁵ (0.014 oz-in-s ²)
Rotary Pin / Collet Runout ⁽²⁾		microns	<25
Maximum Load ⁽³⁾	Axial	kg	3
	Radial	kg	2
	Moment	N-m	3
Stage Mass		kg	5
Minimum System Air Pressure ⁽⁴⁾		psig	100
Finish	Stage / Body	n/a	Electroless Nickel plated Al
	Collet Chuck	n/a	Hardened 440C stainless steel/NiCoTef
<p>(1) ASR1100 collet chuck accepts Rego-Fix ER collets manufactured to DIN6499 specifications only.</p> <p>(2) Measured TIR of precision gage pin chucked with an ultra precision ER collet (DIN6499) 10 mm away from collet face.</p> <p>(3) Maximum loads are mutually exclusive. Loading limits are due to the collet chuck mechanism. Contact Aerotech directly if part load requirement exceeds specifications.</p> <p>(4) Collet chuck mechanism is normally-closed. Collet mechanism requires air to open collet chuck. Air supply must be dry (0°F dew-point) oil-less air OR 99.99% pure Nitrogen. Air or nitrogen must be filtered to 0.25 micron particle size or better.</p>			

Table 3-3: ASR1100 Motor Specifications

Model	BM250	
Performance Specifications (1,5)		
Stall Torque, Continuous (2,8)	N-m	2.0
	oz-in	285
Peak Torque (3)	N-m	5.0
	oz-in	712
Rated Speed	rpm	4,000
Rated Power Output, Continuous	watts	671
Electrical Specifications (5)		
BEMF Constant (line to line, max)	Volts pk / krpm	28.0
Continuous Current, Stall (2,8)	Amp pk	10.5
	Amp rms	7.4
Peak Current, Stall (3)	Amp pk	26.3
	Amp rms	18.6
Torque Constant (4,9)	N-m / Amp pk	0.19
	oz-in / Amp pk	27.1
	N-m / Amp rms	0.27
	oz-in / Amp rms	38.4
Motor Constant (2,4)	N-m / \sqrt{W}	0.171
	oz-in / \sqrt{W}	24.24
Resistance, 25 °C (line to line)	ohms	1.1
Inductance (line to line)	mH	1.30
Maximum Bus Voltage	VDC	340
Thermal Resistance	°C / W	0.94
Number of Poles	P	8
<p>(1) Performance is dependent upon heat sink configuration, system cooling conditions, and ambient temperature</p> <p>(2) Values shown @ 130 °C rise above a 25 °C ambient temperature, with motor mounted to a 250 mm x 250 mm x 6 mm aluminum heat sink</p> <p>(3) Peak torque assumes correct rms current, consult Aerotech</p> <p>(4) Torque Constant and Motor Constant specified at stall</p> <p>(5) All performance and electrical specifications +/- 10 percent</p> <p>(6) Maximum winding temperature is 155 °C</p> <p>(7) Ambient operating temperature range: 0 °C - 25 °C, consult Aerotech for performance in elevated ambient temperatures</p> <p>(8) De-rate continuous torque and continuous current by 10 percent when using an encoder</p> <p>(9) All Aerotech amplifiers are rated Apk; use torque constant in N-m / Apk when sizing</p>		

3.4. Load Capability

The ASR1100 is designed for tubular manufacturing applications. With this in mind, the tubes loaded into the collet chuck of the rotary axis must fall within the max load parameters outlined in Table 3-2.

NOTE: Maximum loads are mutually exclusive; loading limits are due to the collet chuck mechanism. Contact Aerotech directly if part load requirement exceeds specifications.

Chapter 4: Maintenance

This chapter will cover information about component replacement, intervals between lubrications, detail the lubrication and inspection process, and cover which lubricants are recommended for use.



To minimize the possibility of bodily injury, confirm that all electrical power is disconnected prior to making any mechanical adjustments.

Although the ASR1100 is designed to be low maintenance, there are a few items that may require preventative maintenance during the lifetime of the stage. This chapter will detail the lubrication, inspection, and replacement process of various components.



It is recommended that rotary seals be replaced at a minimum of every 1000 hours of service or until a definitive trend develops. Refer to Section 0.0.1. for more details.

4.1. Service and Inspection Schedule

Seal inspection and replacement in ASR1100 series stages depends on conditions such as duty cycle, speed, and the environment. A frequent inspection interval is recommended until a trend develops for the application. As part of this inspection interval, the seals should be examined for excessive air or water leakage. The application will determine the required replacement interval for the seals. The bearings, motor, and encoder require no lubrication or maintenance.

4.2. Cleaning and Lubrication

O-rings and collet piston seals should be lubricated with with Parker O-Lube lubricant or an equivalent o-ring lubricant.

Any metal parts may be cleaned with either acetone or isopropyl alcohol. Seals and o-rings may be wiped with a small amount of isopropyl alcohol if necessary.



Acetone should never be used to clean the o-rings or seals.

4.2.1. Collet & Collet Chuck Lubrication and Cleaning

For the collet chuck and collet to operate properly, preventative maintenance and regular cleaning is required.



Failure to lubricate and clean the collet interface surfaces will cause premature failure and wear that can void the warranty.

Before inserting any collet into the chuck, clean the chuck taper and the collet with acetone or isopropyl alcohol with a lint free cloth a rag. If necessary, you can use compressed air to clean out the collet grooves. Inspect the collet and the chuck interface surfaces to confirm that no marks are present. If wear or fret marks (copper colored oxide marks) are present, you can lightly polish the taper with a fine grit crocus cloth. You should clean the surface without removing an excessive amount of material. If the wear marks are large or excessive polishing is required to remove these marks, the taper and the collet might need to be replaced. Contact Aerotech customer service for more information.

After inspection and cleaning, grease the chuck taper and collet taper with a small amount of lubricant and insert the collet. Table 4-1 shows the lubricants recommended by Aerotech.

Table 4-1: Recommended Lubricants

Vender	Product	Item #	Description
Henkel Technologies	Loctite	80209	Silver Grade Anti-Seize
Henkel Technologies	Loctite	51168	Food Grade Anti-Seize
Jet Lube	White Knight	16404	Food Grade Anti-Seize

Lubricant inspection and replenishment depends on conditions such as collet chuck duty cycle and the surrounding environment. An inspection interval of once every eight hours is recommended until a trend develops for the application. Longer or shorter intervals might be required to maintain a film of lubricant on the collet taper. Every time you remove a collet you should clean, inspect, and grease the collet and chuck interface surfaces.

4.3. Seal Replacement

4.3.1. Piston Seal Change Procedure

The collet chuck on the ASR1100 is equipped with o-ring piston seals that are designed to last many collet chuck (open/close) cycles. However, due to regular wear, the seals may require replacement during the lifetime of the product. If trouble with the piston seals is suspected, it is recommended that you contact Aero-tech customer service. The seals should only be replaced by a qualified Aerotech technician.

Appendix A: Warranty and Field Service

Aerotech, Inc. warrants its products to be free from defects caused by faulty materials or poor workmanship for a minimum period of one year from date of shipment from Aerotech. Aerotech's liability is limited to replacing, repairing or issuing credit, at its option, for any products that are returned by the original purchaser during the warranty period. Aerotech makes no warranty that its products are fit for the use or purpose to which they may be put by the buyer, where or not such use or purpose has been disclosed to Aerotech in specifications or drawings previously or subsequently provided, or whether or not Aerotech's products are specifically designed and/or manufactured for buyer's use or purpose. Aerotech's liability or any claim for loss or damage arising out of the sale, resale or use of any of its products shall in no event exceed the selling price of the unit.

Aerotech, Inc. warrants its laser products to the original purchaser for a minimum period of one year from date of shipment. This warranty covers defects in workmanship and material and is voided for all laser power supplies, plasma tubes and laser systems subject to electrical or physical abuse, tampering (such as opening the housing or removal of the serial tag) or improper operation as determined by Aerotech. This warranty is also voided for failure to comply with Aerotech's return procedures.

Laser Products

Claims for shipment damage (evident or concealed) must be filed with the carrier by the buyer. Aerotech must be notified within (30) days of shipment of incorrect materials. No product may be returned, whether in warranty or out of warranty, without first obtaining approval from Aerotech. No credit will be given nor repairs made for products returned without such approval. Any returned product(s) must be accompanied by a return authorization number. The return authorization number may be obtained by calling an Aerotech service center. Products must be returned, prepaid, to an Aerotech service center (no C.O.D. or Collect Freight accepted). The status of any product returned later than (30) days after the issuance of a return authorization number will be subject to review.

Return Procedure

After Aerotech's examination, warranty or out-of-warranty status will be determined. If upon Aerotech's examination a warranted defect exists, then the product(s) will be repaired at no charge and shipped, prepaid, back to the buyer. If the buyer desires an airfreight return, the product(s) will be shipped collect. Warranty repairs do not extend the original warranty period.

Returned Product Warranty Determination

After Aerotech's examination, the buyer shall be notified of the repair cost. At such time, the buyer must issue a valid purchase order to cover the cost of the repair and freight, or authorize the product(s) to be shipped back as is, at the buyer's expense. Failure to obtain a purchase order number or approval within (30) days of notification will result in the product(s) being returned as is, at the buyer's expense. Repair work is warranted for (90) days from date of shipment. Replacement components are warranted for one year from date of shipment.

Returned Product Non-warranty Determination

At times, the buyer may desire to expedite a repair. Regardless of warranty or out-of-warranty status, the buyer must issue a valid purchase order to cover the added rush service cost. Rush service is subject to Aerotech's approval.

Rush Service

On-site Warranty Repair If an Aerotech product cannot be made functional by telephone assistance or by sending and having the customer install replacement parts, and cannot be returned to the Aerotech service center for repair, and if Aerotech determines the problem could be warranty-related, then the following policy applies:

Aerotech will provide an on-site field service representative in a reasonable amount of time, provided that the customer issues a valid purchase order to Aerotech covering all transportation and subsistence costs. For warranty field repairs, the customer will not be charged for the cost of labor and material. If service is rendered at times other than normal work periods, then special service rates apply.

If during the on-site repair it is determined the problem is not warranty related, then the terms and conditions stated in the following "On-Site Non-Warranty Repair" section apply.

On-site Non-warranty Repair If any Aerotech product cannot be made functional by telephone assistance or purchased replacement parts, and cannot be returned to the Aerotech service center for repair, then the following field service policy applies:

Aerotech will provide an on-site field service representative in a reasonable amount of time, provided that the customer issues a valid purchase order to Aerotech covering all transportation and subsistence costs and the prevailing labor cost, including travel time, necessary to complete the repair.

Company Address Aerotech, Inc.
101 Zeta Drive
Pittsburgh, PA
15238-2897

Phone: (412) 963-7470

Fax: (412) 963-7459

Appendix B: Technical Changes

Table B-1: Current Changes (1.02.00)

Section(s) Affected	General Information
Section 1.6.	Section added
Section 3.1.	Section added
Chapter 2: Installation, Section 2.1. , Section 2.3. , Section 2.6. , and Section 1.5.	Safety information and warnings added
Section 3.3.	Motor specifications added

Table B-2: Archived Changes

Revision	Section(s) Affected	General Information
1.00.00	--	New Manual
1.01.00	Section 4.2.1.	Collet cleaning and lubrication procedure updated

Index

A		E	
accuracy.....	10	Electrical Installation.....	16
accuracy and temperature.....	17	Environmental Specifications.....	17
air		I	
compressed.....	16	inspection schedule.....	21
nitrogen.....	16	installation.....	9
requirements.....	16	collet.....	13
air leakage.....	16	L	
Attaching the Payload.....	12	leakage (air).....	16
C		load capability.....	19
cable.....	3, 16	lubrication	
changing ASR workholding devices.....	13	collet/collet chuck.....	22
cleaning		o-rings.....	22
collet/collet chuck.....	22	piston seals.....	22
metal.....	22	Lubrication.....	22
Cleaning.....	22	M	
collet chuck option.....	4	maintenance.....	21
collet installation.....	13	model numbers.....	4
collet removal.....	13	N	
collet/collet chuck		nitrogen.....	16
cleaning.....	22	O	
lubrication.....	22	operating specifications.....	17
compressed air.....	16	options.....	3-4
connector options.....	4	-10 drive motor.....	4
D		-MP mounting plate.....	4
Declaration of Incorporation.....	8	-NC collet chuck.....	4
Dimensions.....	5	-WRENCH.....	4
drive motor options.....	4	controller.....	3
		electronics.....	3

mounting plate.....	3
rear seals.....	4
wrenches.....	3
overview.....	1

P

performance (temperature).....	17
piston seal replacement.....	23
position transducer options.....	4
Preparing the Mounting Surface.....	10

R

rear seal options.....	4
requirements	
air.....	16
rotary axis.....	2

S

safety procedures.....	6
seal replacement.....	23
Securing the Stage to the Mounting Surface.....	11
service schedule.....	21
specifications	
overview.....	17
temperature.....	17
Specifications.....	18
stage distortion.....	10
Standard Features.....	2

T

temperature and accuracy.....	17
-------------------------------	----

U

Unpacking and Handling the Stage.....	9
---------------------------------------	---

W

Warnings.....	6
workholding devices.....	13
wrenches.....	3

Reader's Comments

ASR1100 Series Stage Manual P/N: EDS131, February 21, 2011 Revision 1.02.00 Please answer the questions below and add any suggestions for improving this document.	
--	---

Is the manual:	Yes	No
Adequate to the subject		
Well organized		
Clearly presented		
Well illustrated		

How do you use this document in your job? Does it meet your needs? What improvements, if any, would you like to see? Please be specific or cite examples.

	Stage/Product Details		Name	
Model #			Title	
Serial #			Company Name	
Date Shipped			Address	
Customer Order #				
Aerotech Subsidiary Order #			Email	

Mail your comments to:	Fax to:
Aerotech, Inc. 101 Zeta Drive Pittsburgh, PA 15238 U.S.A.	412-967-6870
	Email:
	service@aerotech.com

