

- Achieves over 160% Fy, categorizing it as a Type 2 splice
- Available in #4-#18 sizes
- Complete System (Sleeve and Grout)
- Offered in Plain or Epoxy-Coated
- Grout ports are equal size
- Ports accept ASTM Standard 3/4" SCH 40 PVC
- Centering pins
- Integral rebar stop
- Integrated positioning feet



## Table of Contents

1.0	Scope .....	1
2.0	Disclaimer .....	1
3.0	Warranty Information .....	1
4.0	Approvals/Compliances .....	2
5.0	Components .....	2
5.1	D410 Sleeve-Lock Grout Sleeve .....	3
5.2	D490 Sleeve-Lock Grout .....	4
5.3	D491 Sleeve-Lock Seal Plug .....	4
5.4	D492 Sleeve-Lock Form Plug .....	4
5.5	D493 Sleeve-Lock ¾" SCH40 PVC .....	4
5.6	Sleeve-Lock Port Plug .....	5
6.0	Engineering .....	5
6.1	How to Specify .....	5
6.2	Sleeve Size Selection .....	5
6.3	Sleeve Spacing .....	5
6.4	Concrete Cover .....	5
6.5	Bar Embedment .....	5
6.6	Epoxy Coated Reinforcing .....	5
7.0	Installation .....	6
7.1	Factory Installation .....	6
7.1.1	Determining Reinforcing Bar Length .....	6
7.1.2	Using Sleeve-Lock Accessories .....	7
7.1.3	Mold Installation .....	8
7.1.4	Pre-Concrete Inspection .....	8
7.1.6	Mold Removal .....	8
7.1.7	Final Precast Inspection .....	8
7.1.8	Transportation and Storage Precautions .....	9
7.2	Field Installation .....	9
7.2.1	Erection .....	9
7.2.3	Installing Bedding Mortar .....	11
7.2.3.1	Pre-Bedding .....	11
7.2.3.2	Post-Bedding .....	12
7.2.3.3	Bedding Materials .....	12
7.2.4	Mixing Grout .....	13
7.2.5	Grouting .....	15
7.2.6	Cleaning .....	16
7.2.7	Curing .....	17
8.0	Troubleshooting .....	18
9.0	Frequently Asked Questions (FAQs) .....	19
9.1	Engineering .....	19
9.2	Purchasing .....	19
9.3	Production .....	20
9.4	Field .....	20
9.5	Quality Control Testing .....	21



## 1.0 Scope

This Application Guide shows the engineering and application details for the D410 Sleeve-Lock® Grout Sleeve as used to splice concrete reinforcement in precast and cast-in-place structures.

Structural design and details outside of those relating to the D410 Sleeve-Lock Grout Sleeve System shall be in accordance with the local specifications, codes, drawings, engineering, and other design requirements which are not provided for within this Application Guide.

## 2.0 Disclaimer

Only Dayton Superior Corporation (DSC) authorized materials should be used to make D410 Sleeve-Lock Grout Sleeve connections. Splicing is not to occur except as detailed in the Application Guide. No material alterations are permitted without the manufacturer's explicit authorization. No substitution for DSC material is permitted without the manufacturer's explicit authorization. Failure to comply to these guidelines and with this Application Guide may result in hazardous conditions to the user and/or installation site.

## 3.0 Warranty Information

DSC affirms that the D410 Sleeve-Lock Grout Sleeve and accessories, as described in this Application Guide, will be free of defects in workmanship and quality provided they are installed by the approved installation procedures, herein.

DSC warrants components of the D410 Sleeve-Lock Grout Sleeve System for a 60 day period from date of purchase and before installation, and is limited to replacement of defective parts. The warranties provided in the obligations and liabilities of DSC are exclusive. The purchaser hereby waives all of the remedies, warranties, guarantees of liabilities whether expressed or implied. No one is authorized to make any warranty or representation as to the use of this product other than those set forth in the DSC Application Guide, brochures, general literature and data sheet.

In no event shall DSC be liable for consequential or special damages or other charges for adjustments, repairs, replacement of parts, installation or other work which may be done upon, or in connection with, such product by the purchaser. Rust on the surface of the product, to the extent limited by ACI 318 shall not be construed as a defect.

The instructions for installing the grout in the sleeves are thoroughly outlined in this manual. Failure to follow these processes will void any and all warranties.

D410 Sleeve-Lock Grout Sleeves are designed to structurally join reinforcing bars. Responsibility lies with the structural engineer to specify the correct size, location, strength and distribution of reinforcing bars to achieve a structurally sound connection between concrete elements.

Any products listed in the Application Guide which are manufactured or supplied by firms other than DSC are mentioned for the convenience of the user. DSC does not warrant nor guarantee the performance of products supplied by others. All requests for information, technical assistance, or purchase orders should be referred directly to those manufacturers or suppliers.

The user should contact DSC to determine that the latest revision of this document is being used and or that no warranty information has changed.

## 4.0 Approvals/Compliances

- ACI 318-11 Type 2
- ICC AC-133
- CALTRANS Ultimate Splice
- Ministries of Transportation, Canada
- Army Corps of Engineers, CW 03210
- State Departments of Transportation, USA
- AASHTO
- International Building Codes (IBC)
- City of Los Angeles Department of Building and Safety

## 5.0 Components

The D410 Sleeve-Lock Grout Sleeve System is a complete reinforcing bar connection system. It enables rebar within precast members to be joined at the job site. All system components are available through DSC and some are available at local suppliers.

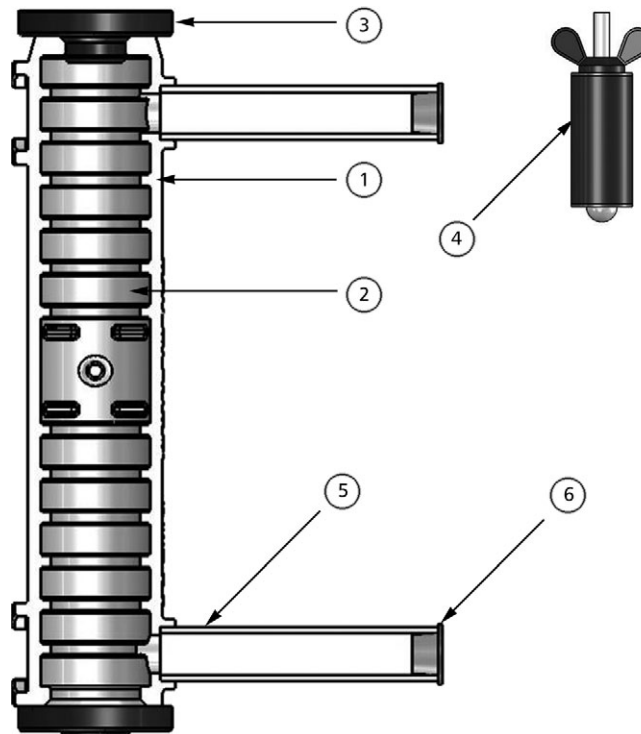

Item No.	Cat ID	Description	Included	Order Separately	Obtain Locally
1	D410	Sleeve-Lock® Grout Sleeve	X		
2	D490	Sleeve-Lock® Grout		X	
3	D487	Sleeve-Lock® Seal Plug		X	
4	D491	Sleeve-Lock® Form Plug		X	
5	D492	Sleeve-Lock® ¾" SCH40 PVC		X	X
6	D493	Sleeve-Lock® Port Plug		X	

*Figure 1 Sleeve-Lock Components and Availability*

### 5.1 D410 Sleeve-Lock Grout Sleeve

The D410 Sleeve-Lock Grout Sleeve is a metal casting capable of connecting two pieces of steel reinforcing when assembled using the manufacturer’s recommended installation procedures. The Sleeve has several unique features as shown in Figure 2:

- **Rebar Stop** – An integrated post that acts as a precise stop when inserting rebar.
- **Alignment Fins** – Positioning fins that keep inserted rebar centered.
- **Standard Port Sizes** – Ports designed to accept standard 0.75" SCH40 PVC; ports use the same size PVC.
- **Stacking Feet** – Feet used to stabilize the product during shipping and on the shelf while assisting in wire-tying and acting as a platform for a rebar chair.
- **Made In USA** – The sleeve is 100% made in the USA.

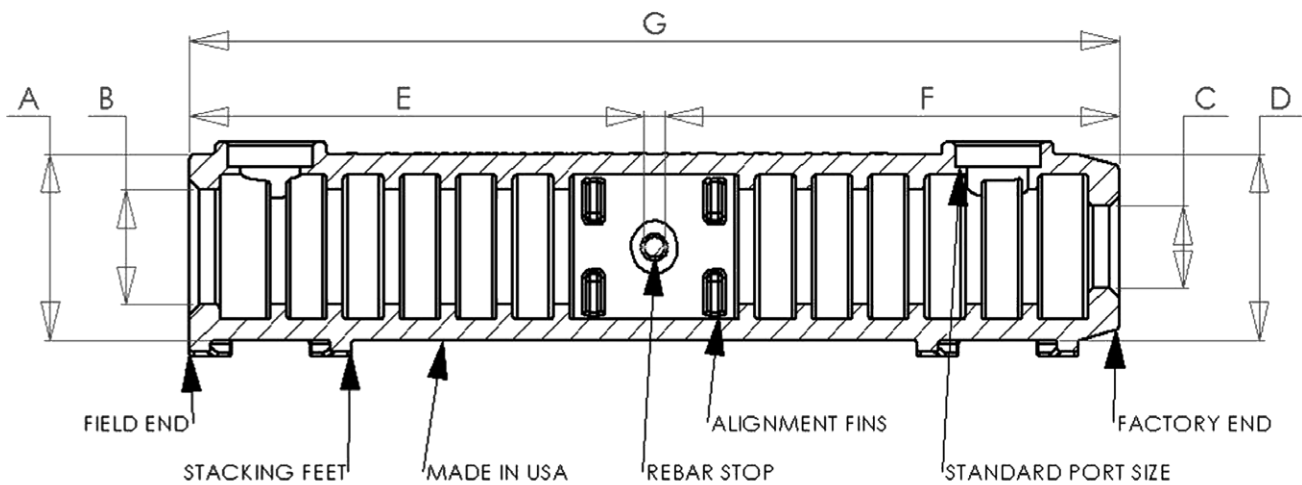

**Figure 2** D410 Sleeve-Lock Grout Sleeve Cut Away

SIZE		SLEEVE-LOCK DIMENSIONS					EMBEDMENT LENGTH			
		A	B	C	D	G	E, MAX	E, MIN	F, MAX	F, MIN
#4	13MM	2.14	1.26	0.87	2.14	9.50	4.63	3.30	4.63	3.30
#5	16MM	2.14	1.26	0.87	2.14	9.50	4.63	4.13	4.63	4.13
#6	19MM	2.61	1.73	1.14	2.61	13.00	6.38	4.92	6.38	4.92
#7	22MM	2.61	1.73	1.14	2.61	13.00	6.38	5.71	6.38	5.71
#8	25MM	2.89	2.01	1.42	2.89	16.52	8.07	6.50	8.07	6.50
#9	29MM	2.89	2.01	1.42	2.89	16.52	8.07	7.40	8.07	7.40
#10	32MM	3.04	2.16	1.57	3.04	17.99	8.75	8.19	8.75	8.19
#11	36MM	3.32	2.32	1.73	3.32	19.54	9.52	8.98	9.52	8.98
#14	43MM	3.73	2.60	2.01	3.73	24.50	12.00	11.42	12.00	11.42
#18	57MM	4.77	3.27	2.68	4.77	36.00	17.75	17.00	17.75	17.00

All dimensions are in inches.

**Table 1** Sleeve-Lock Grout Sleeve

## 5.2 D490 Sleeve-Lock Grout

The D490 Sleeve-Lock Grout is specifically designed and manufactured by Dayton Superior for the Sleeve-Lock System. It is a flowable grout capable of achieving 12,000 psi (82.7 Mpa) in 28 days when mixed following the recommended mixing instructions of Dayton Superior. Available in 50 lb bags, yield per bag, noting that grout used in PVC tubing is not accounted for, is as shown in Table 2:

SIZE		SLEEVES PER BAG OF GROUT
#4	13MM	37
#5	16MM	40
#6	19MM	16
#7	22MM	30
#8	25MM	11
#9	29MM	11
#10	32MM	9
#11	36MM	8
#14	43MM	5
#18	57MM	3

*Amounts are approximate*

**Table 2 D490 Sleeve-Lock Grout Usage by Size**

Use only potable water for mixing. A 50 pound (22.7 kg) bag of grout will require approximately 6.5 pints (3.07 liters) of water to achieve a flowable consistency. The water amount can be adjusted to a maximum of 7.0 pints (3.31 Liters) to achieve desired consistency. Determine the correct water amount by mixing a test batch prior to commencing grout operations.

## 5.3 D491 Sleeve-Lock Seal Plug

The D491 Sleeve-Lock Seal Plug is a rubberized plug used to seal the connection between the D410 Sleeve-Lock Grout Sleeve and the reinforcing bar. It is designed to keep concrete from entering the inner cavity of the D410 Sleeve-Lock Grout Sleeve on the Factory End and to contain the pumped in grout on the Field End. Per size, the Sleeve-Lock Seal Plug can be used on either end meaning that only 1 size Sleeve-Lock Seal Plug (qty 2) per sleeve need be stocked.

## 5.4 D492 Sleeve-Lock Form Plug

The D492 Sleeve-Lock Form Plug is a device using a rubberized grommet and a clamping device and used to attach the D410 Sleeve-Lock Grout Sleeve to a piece of formwork i.e. steel, lumber, composite. It is designed to fasten the sleeve to the formwork while keeping concrete out of the sleeve's inner chamber. It is to be used on the Field End only and is not designed to be used as a structural connection.

## 5.5 D493 Sleeve-Lock ¾" SCH40 PVC

The D493 Sleeve-Lock ¾" SCH40 PVC is standard, off the shelf, PVC, used to fill the inner chamber of the D410 Sleeve-Lock Grout Sleeve. Either port of the sleeve uses the same size PVC. It is available locally or through Dayton Superior.



## 5.6 Sleeve-Lock Port Plug

The Sleeve-Lock Port Plug is a plastic plug used during jobsite shipping to plug the ports in order to keep debris from entering the inner chamber of the sleeve. They can also be used to plug the PVC before or after grouting. One size will fit either end port or PVC.

## 6.0 Engineering

### 6.1 How to Specify

**Specific:** Mechanical splices shall be the D410 Sleeve-Lock Grout Sleeve manufactured by Dayton Superior Corporation.

**Generic:** The mechanical connection shall meet building code requirements of developing in tension and compression, as required, by local standards and codes. Grouting must be performed in accordance with the manufacturer's recommended grouting procedures.

### 6.2 Sleeve Size Selection

To splice bars of the same size, select the corresponding size sleeve to match. When splicing bars of different sizes, select the corresponding largest bar's sleeve.

### 6.3 Sleeve Spacing

Consult local relevant building codes and/or ACI 318 for minimum spacing design.

### 6.4 Concrete Cover

Dependant on relevant code requirements for intended service or exposure to weather, the distance for required concrete cover must be maintained from the concrete surface to either surface of the sleeve or of the stirrup bar over the sleeve.

### 6.5 Bar Embedment

Refer to the dimensions in Table 1. The Factory End reinforcing: the bar inserted in the factory in the narrow end, shall be designed as close to maximum specified length so as to reach the Rebar Stop. The Field Dowel, the bar inserted in the field during erecting in the wide end, shall be designed with consideration of field gap and tolerance.

### 6.6 Epoxy Coated Reinforcing

The D410 Sleeve-Lock Grout Sleeve may be used to connect epoxy coated reinforcing. The epoxy coating on the rebar embedded in the sleeve does not have to be removed. The sleeve can be ordered epoxy coated so that integrity of the epoxy coating is maintained.

## 7.0 Installation

The D410 Sleeve-Lock Grout Sleeve has two different installation procedures depending where the process is occurring. The first installation process, Factory Installation, is completed typically in the precast facility. The second installation process, Field Installation, is completed typically at the jobsite.

### 7.1 Factory Installation

#### 7.1.1 Determining Reinforcing Bar Length

The Length of the protruding rebar from the forms (P) is equal to the embedment length (F) from Table 1 above plus the design depth of the joint gap (J) and the design depth of the floor slab (S) such that:

$$\text{Total Protrusion Length, } P = F + J + S \text{ where:}$$

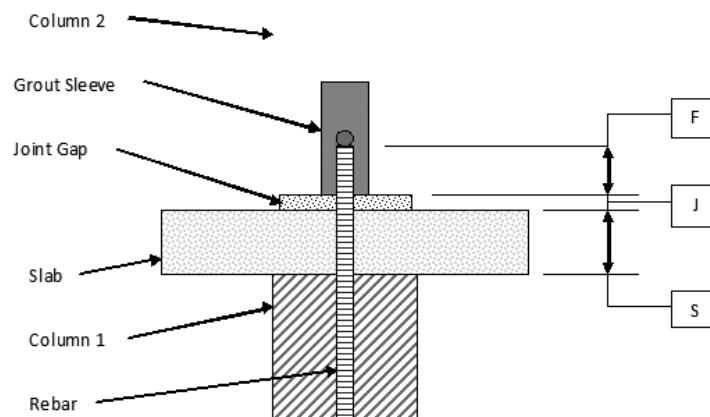

**Figure 3** Column Connection Dimensions

The total required length of reinforcing bar (L) is equal to the distance from the interior of one form to another (K) plus the required protrusion from above (B) less an embedment length (E) and center post diameter (H) from Table 1, such that:

$$\text{Total Rebar Length, } L = K + B - E - H \text{ where:}$$

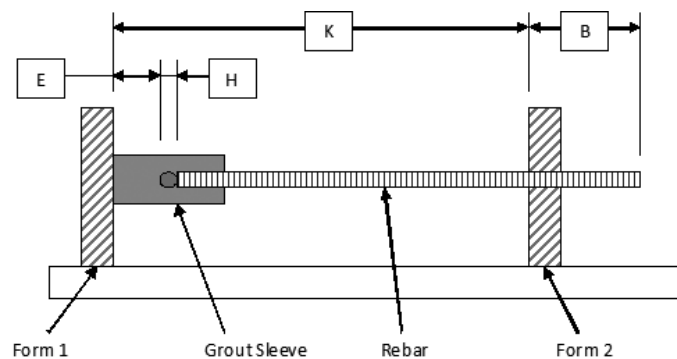

**Figure 4** Precast Layout Dimensions

The equations in Figure 3 and Figure 4 are optimum. Allowances could be made for tolerances and error in design and cutting.

It is essential that the reinforcing bars be cut accurately to the specified tolerance. It is necessary to set a bar stop on the bar cutting machine and to make certain the bar is secured tightly against the stop before cutting. The bar fabricator should be cautioned that tolerances used for cutting bars for use in cast-in-place concrete are not acceptable for use with this type of connection. Cutting tolerance should be limited to not more than  $\pm 1/8$  inch for a total of  $1/4$  inch. Short bars should not be accepted.

### 7.1.2 Using Sleeve-Lock Accessories

To install the D487 Sleeve-Lock Seal Plugs, the molded rubber parts should be inserted, tip end first into the Factory End of the sleeve.

Installing the D492 Sleeve-Lock  $3/4$  inch SCH40 PVC Grout Tubes is as easy as inserting the tubes into the ports. The ports are designed to accept American Standard ASTM Schedule 40 PVC pipe sizes. Typically, straight, ridged PVC pipe is recommended for both ports. In special applications, flexible grout tubes may be used. Care must be taken to assure that the flexible tubes do not become kinked or collapse during casting. The user is cautioned that such tubing will be difficult to clear in the event an obstruction lodges in the tubing. The ends of the PVC should be cut flush with the top of the forms or the surface of the poured concrete. To secure the tubes before casting operations, it is important to wire tie the tubes to other fixed members like reinforcing bar.

If a fixed connection is desired between the tubing and the sleeve, electrical tape can be used around the tube diameter that will be inserted into the sleeve. This will make the fit tighter and may require additional force to insert. Care must be taken to not fracture the tube.

To determine the length of the PVC tubing, a reduction of the distance (M) from the centerline of the rebar to the surface of the concrete must be accounted for. This factor comes from the seating surface within the sleeve for the tube to the centerline of the sleeve:

SIZE		M
#4	13MM	0.88
#5	16MM	0.88
#6	19MM	1.22
#7	22MM	1.22
#8	25MM	1.35
#9	29MM	1.35
#10	32MM	1.52
#11	36MM	1.60
#14	43MM	1.75
#18	57MM	2.19

*Dimensions in inches*

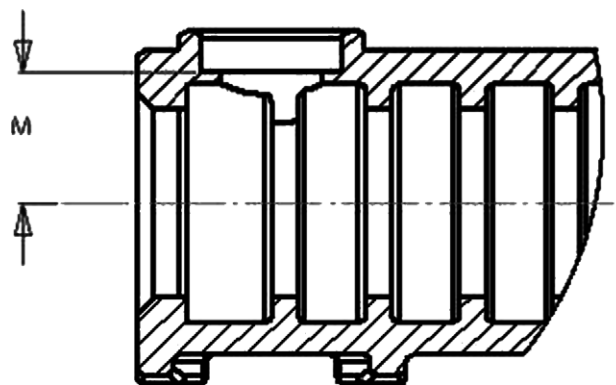

**Figure 5** PVC Tube Reduction Factor

To ensure that concrete does not enter the PVC tubes, the D493 Sleeve-Lock Port Plugs can be inserted into the PVC tube ends. This is done by pushing the tip of the plugs into the hole of the tubes.

### 7.1.3 Mold Installation

To install the D410 Sleeve-Lock Grout Sleeve into the molds and against the forms, the Sleeve-Lock Form Plug can be used to ensure that concrete does not seep into the inner chamber of the sleeve. To install, insert the threaded rod through the formwork leaving only the clamping device and bushing on the outside of the form. On the inside, put a washer, rubber grommet, another washer, and the nut in that order, threading the nut on the threaded rod until the unit is finger tight against the form. Push the sleeve Field End onto the rubber grommet until the outside face of the sleeve is against the form. Hold the sleeve firm against the form and flip the arm of the clamping device downward. This will force the rubber grommet to swell making the connection of the sleeve to the form and become “concrete tight”.

Once against the form, rebar can be inserted in the Factory End making sure to support the reinforcing bar in accordance with local building codes.

### 7.1.4 Pre-Concrete Inspection

Check the following prior to pouring concrete:

1. Sleeves are free from debris and match the size corresponding to the design.
2. Correct size Sleeve-Lock Seal Plugs are inserted into the sleeves and tie wires are used to secure the assembly.
3. Sleeves are properly and firmly secured in the mold.
4. Rebar is up against the rebar stops.
5. After assuring that the bars are up against the rebar stops, check to see that the lengths of rebars protruding from the mold are within the allowable tolerances. Long bars may be cut back later. Short bars must be replaced before casting.
6. Reinforcing bars and sleeves are held in position and properly supported with chairs, etc.
7. Grout tubes are securely attached on the sleeve and sealed properly with Sleeve-Lock Port Plugs
8. Grout tubes are long enough to reach to or through the form and are securely fastened at the forms.

### 7.1.5 Concrete Pouring

During the pouring and operation of the internal vibrator, care should be exercised not to displace the sleeves, rebar, and accessories from their installed position.

### 7.1.6 Mold Removal

After pouring concrete into the mold, and before Steam-Curing, loosen the nut of the D491 Sleeve-Lock Form Plug. This helps lengthen the service life of the Form Plug.

Once Steam-Curing has been complete, remove the side mold with the Form Plug intact. These can be unclamped and reused at a later time.

### 7.1.7 Final Precast Inspection

Check the following after concrete member has been removed from the form.

1. Using a bright light, visually check the interior of each sleeve by looking through the open end, as well as grout tubes if present. Make sure that there are no foreign substances present (ice, water, dirt, debris, etc.). If foreign materials are present, clean and flush out the contaminating materials with compressed air or water.

2. Check that the length of protruding bars is within allowable tolerances. When bars are not carried out the other end of the precast element, it is important to securely fasten them in the form so that they will not be displaced out of the sleeve during concrete placement.
3. Using a bright light, inspect the bar embedment length in the sleeves to be sure that the bars are tight to Rebar Stop.
4. Visually inspect the protruding bars to make sure they are free of bonding-breaking substances, such as oil, heavy rust, dirt, etc.
5. Check the sleeve quantity, bar size, and position for correlation to drawing requirements.
6. Check grout inlet and outlet holes to make certain that they are in the proper position and are not covered with concrete as well as that there is a clear passage from the inlet to the outlet port.

**Caution:** Precast members having embedded bar lengths shorter than the specified minimum length should be referred to the engineer for decision on remedy. If the embedded bars are too long, they may be cut to the proper length.

#### 7.1.8 Transportation and Storage Precautions

While precast members are stored and transported, care should be exercised to prevent:

1. Foreign materials contaminating sleeves, grout inlet or outlet holes.
2. Protruding bars being contaminated by bond-breaking substances such as oil, dirt and excessive rust.
3. Protruding bars from being damaged or bent.

## 7.2 Field Installation

### 7.2.1 Erection

Reinforcing bars which protrude from cast-in-place concrete foundations and which are intended to be connected to precast elements by means of the splice sleeves need to be carefully aligned both in plan and elevation. Bars extending from the foundation or protruding from precast elements to be joined in the D410 Sleeve-Lock Grout Sleeve are termed “dowels” or “rebar anchor dowels” in this section. When the foundation contractor is not the precast concrete supplier, the dowels are very likely to be misaligned or out of tolerance if the foundation contractor is not provided with special installation instructions and templates. This is because the tolerances for placing reinforcing bars under ACI code provisions for cast-in-place concrete are far too great to permit sufficient accuracy for precast concrete connections.

The following recommendations will help assure successful mating of the precast elements to the cast-in-place structure:

1. The designer should include in the specifications for the cast-in-place concrete a requirement that plan location tolerances for reinforcing bars should be  $\pm 1/8$  inch.
2. The precaster should provide the foundation contractor the information necessary to prepare dual templates to hold the foundation bars within tolerances specified above.
3. The foundation contractor should be requested to extend the reinforcing bars above the foundation several (4-6) inches longer than required. The bars can be later cut off to the required elevation after grades have been established and shims have been set.

4. A prudent precast concrete contractor will establish communications and a cooperative relationship with the foundation contractor early in the project.

To locate rebar dowels in the foundation, it is recommended to do the following:

1. The precast concrete manufacturer should furnish the site-work contractor a template for holding the dowels. The template is prepared by drilling holes to accommodate the rebar dowels to match the holes in the side-forms used for making the precast elements. Templates may be made of wood or metal. Plant quality control personnel should check that the holes in the templates are in the correct locations before sending the templates to the job-site. The foundation contractor should use the templates to make dual plates to hold the dowels in horizontal and vertical alignment. In the case of tilt-up or site precast work, side forms for the panels may be re-used as templates for locating the dowels, or templates or locating dowels may be fabricated to function as side forms, depending upon the sequence of construction.
2. Rebar dowels protruding from the foundation should be fabricated so that the vertical extension of the dowels is at least 4" longer than needed.
3. Templates should be accurately located in place and securely fastened. Patterns of dowels that are separated, but within the same precast member should be positioned with a single template assembly.
4. Vertical rebar should be accurately aligned by dual plates and may be secured by tack-welding #3 or #4 rebar to the dowels at the top of the bars. This tack-welded bar will be cut off later and not used in the splice sleeve.
5. The quality control agency or precast concrete manufacturer should check dowels for proper location and alignment before the foundation concrete is placed.
6. Immediately after the concrete for the foundation is poured, the templates and dowels should again be checked to assure that they have not moved during concrete operations.
7. After the concrete has cured, the excess length of dowels, along with the tack bars are cut off.

### 7.2.2 Installing D487 Sleeve-Lock Seal Plugs

Place D487 Sleeve-Lock Seal Plugs on dowel bars protruding from the foundation. The printed size number on the plug must correspond to the size of the rebar on which it is placed. (Plugs and bars may be color-coded by the contractor, if desired, to improve field accuracy). The purpose of the washer is to prevent bedding mortar from entering the sleeve. When bedding mortar is placed prior to setting the precast unit in position, the plug shall be placed just above the bedding mortar surface, with the face with the protrusion away from the sleeve.

When the upper precast element is lowered into position, the plug will prevent bedding mortar from entering the sleeve.

When bedding mortar or concrete topping is placed after the sleeves are grouted, the plugs should be supported tightly against the bottom of the upper precast element. This may be done with foam ring seals, springs, wedges, silicone caulking or similar methods. In most cases, it is best to place bedding mortar and allowing it to achieve at least an initial set before grouting sleeves.

### 7.2.3 Installing Bedding Mortar

Mortar to be used for bedding should conform to the engineer's specifications. The consistency of the mortar should be suitable for the chosen bedding practice. After joining the precast members, the bedding mortar should be completely finished without leaving any unfilled space between the members. Proper curing requirements should be observed.

The use of factory prepared bedding grouts is strongly encouraged and the use of uncontrolled field mixed sand-cement-water materials is emphatically discouraged.

Bedding practices for setting precast elements vary according to regions. Bedding may be placed prior to setting a precast element (pre-bedding or wet-bedding) or after a precast element has been set (post-bedding or dry-packing). Following are some general considerations of installation.

#### 7.2.3.1 Pre-Bedding

Pre-bedding is usually accomplished by placing the mortar bed immediately ahead of installation of the precast unit. An economical labor-saving technique which has been used for wet-bedding is described below.

1. Place temporary "dams" as required.
2. Place the bedding mortar so that there is sufficient quantity to completely fill the joint. It is preferred to overfill the joint space slightly.
3. Check to see that the D487 Sleeve-Lock Seal Plugs are properly placed.
4. Erect the precast member.

Temporary dams made of foam plastic are installed to confine the bedding area. After shims (where needed) have been placed, mortar of a flowable consistency and of the specified strength is poured into the confined space. The temporary dams perform several functions:

1. They confine the bedding mortar.
2. They provide a screed line to assure sufficient depth of mortar bed, and at the same time reducing material waste.
3. When the precast element is set, mortar bedding is surcharged by the weight of the precast member, assuring uniform bedding as well as visual indication (from the overflow) that an adequate amount of mortar was used in the bedding space. Make sure there is an opening(s) in the dam to provide an escape path for excess bedding mortar, so that it does not force past the seal at the Sleeve-Lock Seal Plug into the sleeve.

On floors, the dams used may be made of 1"x1" wood stock, installed temporarily, approximately 1/2 inch (1cm) outside the bottom dimension of the precast element being set. They may also be foam closed-cell glued to the floor. Where there is no horizontal surface available to install wooden strips, such as for columns, shear walls or exterior bearing walls, a square section of foam closed-cell may be used. It is secured to the top of the lower column or wall element around its perimeter with adhesive or strong tape (such as furnace duct tape), and is located within the bedding area. It is notched to provide for overflow of excess mortar. In this type of bedding, the precast element compresses the foam closed-cell dam to the degree permitted by the bedding shim, and at the same time surcharges the bedding mortar. In some cases where exterior bearing or shear walls are used, the foam dam strip used on the

external face of the wall is left in place to form a weather seal function. Normally, however, dams are removed after curing and the joints are struck for finished appearance.

**NOTES:**

1. The type of bedding material used is at the discretion of the specifier.
2. In general, where it has been possible to use pre-bedding rather than post-bedding techniques, labor cost savings have been achieved. However, contemporary practices have been influenced by labor craft jurisdictions, the contractual relationship between contractors, subcontractors and suppliers, and by reluctance to change previously established field practices. It is strongly recommended that the manufacturer of the precast elements maintain control of all grouting procedures including sleeve grouting and bedding.

**7.2.3.2 Post-Bedding**

Post-bedding has been accomplished by using a technique known as "dry-packing" or by pressure grouting.

1. Place temporary dams if and as required.
2. Assure that the D487 Sleeve-Lock Seal Plug is supported tightly against the base of the upper precast element. This may be accomplished with the use of a spring or foam ring. Some erectors have had success putting a bead of silicone caulking around the top surface perimeter of the Sleeve-Lock Seal Plug and seating it up against the underside of the precast at the wide end opening of the sleeve. Sleeves should be grouted after the bedding mortar is placed.

In dry-packing, mortar is hand-forced into a bedding space which has been kept open with the use of shims or leveling bolts. This process is labor-intensive, and it may not be certain whether the mortar bed is adequately transferring the compressive loads or if the shim packs are the principle load-bearing elements. Dry-packing should be done in joints that are at least 1.5" thick.

Pressure-grouting, pumping the bedding mortar into the joint space has also been used in some cases. It is especially appropriate under cold-weather conditions when it has been impractical to install a wet mortar bed because of freezing temperatures. After some external heating has been applied to the precast elements, bedding mortar is pumped into the joint which has been previously confined by use of a foam gasket or mortar dams around the perimeter of the bedding space.

**NOTES:**

When post-bedding methods are used, D487 Sleeve-Lock Seal Plug must be used. If the sleeves are to be grouted after installing the bedding, post-grouting of the sleeves must be delayed until after the bedding mortar has partially hardened. If the sleeves are grouted before the bedding is installed, care should be taken to assure that the washers are firm against the bottom of the upper precast element and secured into position by wedging or other appropriate measures such as a foam ring. The D487 Sleeve-Lock Seal Plug alone will not provide sufficient sealing capability to withstand pumping of D490 Sleeve-Lock Grout into the sleeve.

**7.2.3.3 Bedding Materials**

Bedding materials may be classified as follows:



Factory Formulated or Field-mixed sand-cement Metallic or Non-metallic

The use of field mixed sand and cement mortars is not recommended. The strength of the mortar bedding should be superior to that of the concrete elements on either side of the joint. It is recommended that only factory formulated non-metallic grouts be used for bedding that is exposed to the elements. Metallic grouts can be used if protected from weather.

#### 7.2.4 Mixing Grout

The following preparations should be made:

1. Prepare a daily work schedule.
2. Determine the number and types of sleeves to be grouted.
3. Assign a number to each sleeve shown on the drawing; and correspondingly at the job site on the precast element.
4. Establish the procedure for grout sampling and testing for quality control.
5. Procure electricity and water for mixing. (Hot water in cold weather or cold water in hot weather.)
6. Determine and procure the required quantity of D490 Sleeve-Lock Grout
7. Check the weather and temperature forecast at the jobsite for the day.
8. Review the Grouting Foreman's Checklist.
9. Inspect precast elements immediately before erecting to assure that sleeves and grout tubes are clear and free from restrictions.

Store the grout under temperature controlled conditions from a minimum 50°F (10°C), to a maximum 80°F (27°C).

During cold weather, check the temperature inside the sleeves from the inlet or outlet hole. If temperature is 40°F (4.4°C) or below, the temperature must be raised to above 40°F, as specified in ACI 306. Necessary steps should be taken to prevent freezing of the grout in the sleeves and to maintain curing temperature not lower than 40°F as specified in ACI 306. It is best to maintain a curing temperature above 60°F (15°C) to insure overnight curing results in sufficient compressive strength to remove braces.

During hot weather, necessary steps (such as the use of chilled mixing water) should be taken to keep the mixed grout temperature below 80°F. Avoid excessively high temperatures (above 80°F or 27°C) of mixed grout which may result in premature setting, difficult pumping, and lower strengths than expected.

In adverse conditions, grouting should not be performed under the following conditions:

1. When it is raining or snowing at the jobsite, and there is no shelter or protection to prevent rain or snow from entering into the dry or mixed D490 Sleeve-Lock Grout.
2. When it is anticipated that the grouted members or sleeves will be subjected to harmful vibrations, impacts, or other forces resulting in differential movement of the pieces being joined.
3. When the temperature is anticipated to be below 40°F and no facilities are available to raise and maintain the building temperature and curing temperature above 40°F.

Note that special inspection is required by the Building Code. This is normally accomplished by a certified testing and material laboratory.

Special inspection in the field should cover the following:

1. Check field dowels for proper embedment length.
2. Observe mixing of D490 Sleeve-Lock Grout (temperature, mix ratio, serial number, etc.).
3. Observe and verify grouting of each sleeve (exiting grout, sealing, etc.).
4. Take 2" cube samples of D490 Sleeve-Lock Grout for compressive testing in lab; a set of 3 cubes to test before removing bracing (24 hours±), a set of 3 cubes to test at 28 days, a set of 3 cubes to hold in reserve, if needed.

In order to perform the grouting operation most efficiently, it is necessary to arrange for equipment and assistance if needed in advance of the grouting work.

1. Review the sections of this manual on sleeve grouting and bedding.
2. Notify testing laboratory to provide special inspection during grouting.
3. Arrange for grout manufacturer's field representative to provide training.
4. Procure approved grout: D490 Sleeve-Lock Grout, as approved. Allow at least two weeks for delivery. Check with grout manufacturer for delivery time.
5. Grout Mixer and Pump.
6. Flow Guide from grout manufacturer (to check consistency for pumping)
7. Water supply and hose with nozzle to fit grout port tubes.
8. D487 Sleeve-Lock Port Plugs
9. A measuring cup to measure the correct amount of water for the mix. The correct amount of water will be established at the jobsite. For special assistance, contact the grout manufacturer.
10. A scale to measure the correct weight of water and serve the same purpose as the measuring cup may be used as an alternative.
11. Electric power supply.
12. Cup to collect and save excess grout coming from the outlet port during grouting.
13. Round flat-end punch to remove obstructions from the grout tubes.
14. Sledge hammer to drive the punch.
15. Flashlight or spotlight to check the grout tubes and sleeves for blockage. Use this prior to erection of the precast unit while it is on the ground or on the delivery truck.
16. Heating facilities in cold weather to permit grout to gain strength: Gas or electric radiant heaters, electric blankets and plastic sheets for closing in space.
17. Spatula or putty knife to remove excess grout.
18. Sponge and water to clean area.
19. Thermometer to measure temperature of air and materials

It is important to record the following items:

1. Temperatures: Ambient, Mixing water, Dry grout and Grout as mixed
2. Lot No. of grout used
3. Amount of mixing water used (gal. or lb/50 lb bag)
4. Sizes and numbers of grouted sleeves
5. Amount of grout used for item 4 above
6. Date of grouting

To mix the D490 Sleeve-Lock Grout:

1. First place all water into the mixer or bucket
2. Pour D490 Sleeve-Lock Grout slowly into the mixer while stirring with the mixing paddle.
3. After all materials are in the mixer, mix the grout for a minimum of five (5) minutes.

**NOTES:**

1. Mix D490 Sleeve-Lock Grout to produce the desired mixed consistency for pumping within recommended grout temperatures under jobsite conditions.
2. Use potable water only
3. For mixing grout, use a mixer as recommended elsewhere in this manual. Do not mix by hand. Do not add cement, sand, aggregate or admixtures. Do not add more water than specified. Use a full bag unit for each batch. Do not use D490 Sleeve-Lock Grout if the package is damaged. D490 Sleeve-Lock Grout has a shelf life of approximately 12 months when stored in a cool, dry environment. A production code is printed on each bag. Grout which has been stored beyond the expiration date should be discarded. Locate mixing operations as close to the grouting position as possible. Do not leave the mixed grout in the sun. Failure to mix the materials properly and long enough may cause problems not only with flow and pumping conditions but also with setting time and subsequent strength gain. The mixture should appear uniform and smooth with no lumps.
4. Warm mixing water, not exceeding 90°F (32.2°F), may be used with cold, dry grout or when placing in cold weather. Chilled mixing water, as close to 33°F (0.5°C) as possible, may be used with warm, dry grout or when placing in hot weather.

### 7.2.5 Grouting

In post-grout applications, pump grout into the inlet tube until it flows freely without air bubbles from the outlet.

1. Use an appropriate grout or mortar pump as recommended. First, saturate the pump inside with water.
2. Pour the mixed grout into the hopper of the pump, and operate the pump to push out the water (and cement paste). (Do not use this slurry in the sleeve.)
3. After confirming that a solid stream of grout (without air bubbles) is coming out of the nozzle, stop pumping and insert the nozzle into the grout inlet tube of the sleeve.
4. Keep pumping the grout into the inlet port continuously and slowly (at the rate of one stroke per second in the case of a hand operated pump) until the grout can be observed coming from the outlet hole in a solid flow. Catch the overflow in a cup (return it to the pump hopper later) and seal the outlet hole with D493 Sleeve-Lock Port Plugs, then withdraw the nozzle from the inlet hole and seal it with a rubber stopper.
5. After stoppers have been inserted, flush away any excess grout remaining on the surface of the grout face.
6. After removing the stoppers the next day, finish the recess with plain mortar.
7. When grouting at minimum temperatures, care must be taken to see that the sleeves and grout temperatures do not fall below 40°F (4.4°C), and that the grout is protected from freezing. Heat should be maintained until the grout in the sleeves has reached a minimum of 1,500 psi (10.3 MPa) compressive strength, as determined by testing 2x2x2 inch cubes. It is recommended to maintain at least 60°F (15°C) to ensure normal overnight compressive strength gain for removing braces.

In pre-grout applications, D490 Sleeve-Lock Grout is mixed and then poured or pumped into the wide end opening. Rod with a small diameter wire (coat hanger) to remove entrapped air. Always fill sleeves before placing bedding grout. Erectors often test-fit the piece to make sure all dowels fit properly in the sleeves before they are grouted.

**CAUTION:**

1. After D490 Sleeve-Lock Grout has been mixed, use it within the specified time limits.
2. If pumping is interrupted, keep circulating the mixed grout by operating the pump with the nozzle in the hopper. If shutdown exceeds the time limit specified by the grout manufacturer, discard the grout.
3. Do not remove plugs until the grout has set.
4. While pumping do not let the grout hopper become empty. Never pump air into the sleeves. Sufficient grout bags should be prepared close at hand (especially for #14 and #18 sleeves which have a large capacity) to ensure continuous grouting.
5. Make sure no sleeve is left ungrouted.
6. Be sure to wash the pump thoroughly after each session or before coffee/lunch breaks.
7. Difficulty in pumping and with premature stiffening may result from grout temperatures outside the range recommended by the grout manufacturer.
8. If a sleeve becomes clogged, try clearing outlet port with stiff wire. If still clogged, then immediately flush with water and try to grout, again. Repeat several times, if necessary.
9. If sleeve is plugged, flush with water and report situation to field engineer for instructions.

**7.2.6 Cleaning**

Check the joint between the precast units during and after grouting work is performed. If grout has leaked out of the joint, remove it immediately by flushing with water.

**WARNING**

D490 Sleeve-Lock Grout contains Portland cement and silica sand. Portland cement in combination with water may cause skin irritation, rash, and alkali burns. Prolonged exposure to silica may cause delayed lung injury (Silicosis). There is limited evidence of carcinogenicity of crystalline silica to humans. Do not breathe the dust. Follow safety and health standards for quartz dust. Do not wear contact lenses when working with this product. Remove soiled clothing and wash before reuse.

**FIRST AID**

**Eyes:** Flush with water for 15 minutes, lifting upper and lower lids occasionally; seek medical attention.

**Skin:** Wash with soap and water. Get medical attention if exposure is extensive.

**Inhalation:** Remove person to fresh air.

## DISPOSAL METHOD

This product is not listed as a hazardous waste in Federal regulations when discarded or disposed. Dispose in a landfill in accordance with local regulations. For additional information or personnel protective equipment, first aid and emergency procedures, refer to the product Material Safety Data Sheet (MSDS) on the jobsite or call the grout manufacturer.

### 7.2.7 Curing

Precast units with grouted sleeves should not be moved or loaded before the D490 Sleeve-Lock Grout develops a cube compressive strength of at least 4000 psi (about 290 kgf/cm<sup>2</sup>). For normal temperatures, Technical Data Sheet may be used as a reference for curing time, support removal time, loading, and time of starting subsequent erection operations.

Under normal summer time conditions of temperature and curing, grouted sleeves should be cured at least 24 hours or longer before removal of bracing unless cube specimens are tested that show proper minimum compressive strength to transfer load. The determination of a safe removal time of lateral bracing or other support of a precast member is an engineering decision which may not be predetermined by the instructions in this manual.

The capacity of the sleeves to transfer load is primarily a function of the grout strength, which in turn is dependent on the consistency and curing temperature of the grout material. It is recommended that the structural engineer be consulted to determine a safe schedule for removal of temporary supports. Under cold weather conditions, it is desirable to make grout specimens, cure them under job-site conditions, and test them at various ages, in accordance with Technical Data Sheet.

The mold, with test specimens, should be stored in close proximity to the grouted sleeves, utilizing the same protective means to simulate the same environmental conditions that exist for the grouted sleeve. When D490 Sleeve-Lock Grout achieves a compressive strength of over 1500 psi (105 kgf/cm<sup>2</sup>), it will not be damaged by freezing. Therefore, during cold weather, curing temperature must be maintained above 40°F until the above referenced compressive strength is achieved.

Curing time, support removal time, and the time when additional units may be erected may be determined by testing field-cured grout samples in accordance with Engineering Data Sheet. Check with the sleeve manufacturer for the latest edition.

Keep components undisturbed for at least 24 Hours or until cube specimen tests show minimum compressive strength has been achieved. Under cold weather conditions, or where the unsupported member will be subject to unusual loads, support release time should be decided by the structural engineer.

## 8.0 Troubleshooting

Location	Issue	Fix
In the Factory	Inlet/outlet ports do not reach the surface	Check and mark the position of the ports according to the drawings.
		Chip out the concrete at the marked positions to find the embedded ports.
		Blow out the ports with the air compressors or water and confirm that there is a clear passage from the inlet to outlet port.
	Concrete slurry inside the sleeve.	Insert a steel rod into the port, and hammer it to chip out or hammer to the bar to shake it off.
		Blow out the ports with the air compressors or water and confirm that there is a clear passage from the inlet to outlet port.
	Inlet and/or outlet port is clogged with concrete debris etc. or port plugs.	For debris, insert a steel rod into the ports and hammer it to clear the
For hole seals, use a hooked rod to scrape seals out of the ports.		
Protruding bar short	Blow out the ports with the air compressors or water and confirm that there is a clear passage from the inlet to outlet port.	
	Weld a small nut to compensate the length or weld a bar extension (AWS D1.4) to achieve proper length.	
	Make sure the bar in the sleeve does not break and pass through the Rebar Stop. If it does, consult the engineer of record for decision	
Bar in sleeve does not reach Rebar Stop	Measure the protruding length of opposite end of bar to calculate how much embedment has secured.	
	If it does not secure the minimum required length, consult the engineer of record for decision.	
In the Field	Field dowels from foundation are short	Weld a small nut to compensate the length of the bar.
		If shorter than 5.0D, then weld a bar extension (AWS D1.4)
	Field dowels mislocation	Chip down the concrete, bend the bar over and then back to vertical.
If more than a bar diameter out, cut it off, and drill a new hole to epoxy anchor dowel with proper length.		
Field dowels from foundation too long	Cut to proper length by sawing.	
During Grouting	Inlet/outlet ports do not reach the surface	Check and mark the position of the ports according to the drawings.
		Chip out the concrete at the marked positions to find the embedded ports.
		Blow out the ports with the air compressors or water and confirm that there is a clear passage from the inlet to outlet port.
	Due to omission of seals, the inlet port is clogged with bedding mortar from the joint	Insert a steel rod into the port, and hammer it to chip out the mortar.
		Blow out the ports with the air compressors or water and confirm that there is a clear passage from the inlet to outlet port.
	Inlet and/or outlet port is clogged with concrete debris etc. or port plugs.	For debris, insert a steel rod into the ports and hammer it to clear the
		For hole seals, use a hooked rod to scrape seals out of the ports.
	Concrete, mortar or other obstruction has intruded into the sleeve from the outlet port, and has clogged inside.	Insert a steel rod into the port, and hammer it to break out the obstruction. If this is unsuccessful, drill a new hole for an alternate port in the vicinity of the outlet port.
		Blow out the ports with the air compressors or water and confirm that there is a clear passage from the inlet to outlet port.
Leakage during pumping of grout from the joint due to incomplete mortar bedding.	Seal the joint with rags, polyurethane, mortar etc.	
	Clean the inside of the sleeve with water	
	Confirm a clear passage by blowing air	
Clogging has occurred inside the sleeve such as at point marked during pumping operation	Re-grout	
	Clean the inside of the sleeve with water	
Rebar is too close to the outlet, restricting grout flow	After confirming a clear passage by blowing air, start re-grouting at about half speed of the normal operation	
	Insert heavy punch into outlet grout tube and strike with a sledge hammer to reduce restriction	

## 9.0 Frequently Asked Questions (FAQs)

### 9.1 Engineering

Q: How many bar sizes differential can be accommodated?

A: Any given size sleeve can connect the bar designated or any combination of smaller bars.

Q: What is the difference between a Type 1 and Type 2 splice?

A: Type 1 is 125% of the specified yield strength in tension. Type 2 is typically considered to be 160% of the specified yield strength in tension or per ACI 318-11, 100% of the specified ultimate strength in tension. The Sleeve-Lock Grout Sleeve exceeds all these requirements.

Q: Do I need to specify different grout for Type 2?

A: No, the only grout approved for use in D410 Sleeve-Lock Grout Sleeve is D490 Sleeve-Lock Grout. All components are manufactured and available by Dayton Superior.

Q: Can I use the D410 Sleeve-Lock Grout Sleeve upside down?

A: Yes, this is called Pre-Grout position. The sleeve is filled (pre-grouted) just before the precast piece above is erected. This is especially good to create blind architectural connections.

Q: Do I need to stagger sleeves?

A: No, sleeves are not usually staggered. It is highly impractical to stagger sleeves on either side of a joint. Many tests have been done over the years that show staggering is not necessary. Further, you can refer to the ACI Committee 349 "Code Requirements for Nuclear Safety Related Concrete" that gives design criteria for eliminating staggering that normally is required in Chapter 21 of the ACI 318 code.

Q: How close can I space D410 Sleeve-Lock Grout Sleeves?

A: The D410 Sleeve-Lock Grout Sleeve is treated like it is the rebar. You must be able to get concrete around it. If the maximum size aggregate is  $\frac{3}{4}$ ", then you should maintain at least 1" between sleeves.

Q: How much concrete cover is required over the D410 Sleeve-Lock Grout Sleeve?

A: The D410 Sleeve-Lock Grout Sleeve is treated like it is the main bar. Depending on the exposure, you need to maintain the cover that would have been required over the main bars.

Q: What is the embedment length of a bar and sleeve assembly?

A: The D410 Sleeve-Lock Grout Sleeve is considered to be part of the bar and its length is part of the embedment length for the situation in question.

Q: Can the D410 Sleeve-Lock Grout Sleeve connect Epoxy Coated Rebar?

A: Yes and the coating does not have to be removed. The D410 Sleeve-Lock Grout Sleeve should also be specified as epoxy coated if the bar is coated.

## 9.2 Purchasing

Q: Where can I get help to figure out what to order?

A: Call Dayton Superior Corporation at 888.977.9600 or email to [info@daytonsuperior.com](mailto:info@daytonsuperior.com)

Q: Where do I place an order?

A: Call Dayton Superior Corporation at 888.977.9600

Q: What else do I need to order besides sleeves?

A: That depends on the application. You will probably need PVC tubing if the sleeves are located in Post-Grout position (bottom of piece, above the joint) which can be obtained locally or through Dayton Superior. You will need D491 Sleeve-Lock Form Plug for each sleeve in each form. The field crew will need D490 Sleeve-Lock Grout, a hand grout pump, and mixer blade among other common items. Call us for help with your specific situation.

Q: When can I expect delivery?

A: We have distribution centers across the US. Most orders are shipped by truck to arrive within one week. We can air freight overnight for stocked items by your instruction.

## 9.3 Production

Q: Can we use flexible grout tubing?

A: Flexible tubing is not recommended because the grouting crew may have to clear a plugged port in the field. It is much easier to clear a straight tube with a rod or drill bit. If you must use a flexible tube, make sure the interior is smooth and the tubing as stiff as possible to minimize the risk of collapse. Check all tubing in the plant before shipping precast to the field. Field crews should check tubing on the truck before erecting.

Q: How do you attach PVC tubing to the sleeve?

A: The PVC pushes into the ports of the sleeve. Typically, no other materials are needed, though wire tying the assembly in place is recommended. If a sturdier connection is desired, a PVC cement or adhesive tape may be used.

Q: How do I know the factory rebar is properly embedded?

A: The D410 Sleeve-Lock Grout Sleeve has a Rebar Stop in the middle of the sleeve to set the embedment length. It is also recommended to mark the bar using a jig tube such that the mark appears just outside the D487 Sleeve-Lock Seal Plug as a visual pre-pour check

Q: We are using a #11 sleeve to connect a #9 rebar. Any precautions?

A: Check the Sleeve-Lock Seal Plug to make sure it is sealing around the bar as it enters the sleeve. Adhesive tape may be used to make sure the seal is tight. Make sure the bar is fully embedded in the sleeve (see answer above).

Q: Do I have to saw cut rebar going into D410 Sleeve-Lock Grout Sleeve?

A: No, you can use a saw, shear or torch. No special bar end preparation is required.

Q: What do we do if we lose some accessories?

A: Those accessories can be re-ordered separately.



## 9.4 Field

Q: The rebar anchor dowel coming out of the foundation is too short. What can I do?

A: Weld a short length of rebar or a small nut on the short bar to bring it into tolerance.

Q: The rebar anchor dowels are out of tolerance in plan. What can I do?

A: If the bar is within a bar diameter of correct position, drill a hole similar to the diameter of the bar on the side you need to move it. Bend the bar over such that it is in proper location at the base and insert a steel wedge to hold the position. Then, bend the bar back to vertical pivoting at the wedge. Epoxy or grout the hole around the wedge.

If the bar is more than a bar diameter away, cut it off and drill and epoxy anchor a new bar in the correct location. Choose an epoxy anchoring system that develops the ultimate strength of the rebar.

Q: Can I use any grout besides D490 Sleeve-Lock Grout?

A: No.

Q: How fast does D490 Sleeve-Lock Grout cure?

A: It depends on temperature. In warm weather (70°F+ daytime), it should cure overnight to over 4,000 psi, which should be sufficient to allow removal of bracing. Freezing weather requires the use of radiant heaters to first get the sleeves over 50°F and then to maintain heat overnight.

Q: Do I need a high pressure power pump?

A: No, a hand-operated grout pump is sufficient. We recommend the Kenrich Model GP-2HD/SS. It works well for D490 Sleeve-Lock Grout and can be used all around the job site for other grouting applications.

## 9.5 Quality Control Testing

Q: What kind of inspection is needed on site?

A: ICC recommends that "special inspection" is required. This means that a quality assurance technician should check the rebar anchor dowel lengths to make sure they meet the minimum embedment lengths as specified in the User's Manual. The technician should monitor the grouting operation to verify that all sleeves have been filled and the grout mixed properly. Finally, they should take 2" cube specimens of the grout to test before the removal of bracing and at 28-days.

Q: Can the testing lab use plastic cube molds?

A: No, they must use heavy brass molds with cover plates.

Q: Can the lab use the same testing apparatus as they use for concrete cylinders?

A: No, the test machine must be fitted with the proper supports for 2" cubes. The test values are very high (reaching 14,000 psi) and ASTM procedures must be strictly followed.

Q: How do we know if the sleeve is filled?

A: The proper grouting procedure is to pump into the lower inlet port and catch the grout in a cup. The sleeve should be over-pumped by a few strokes to show that all the air has been pushed out and only a smooth flow of grout is coming from the upper

outlet port. Then, stop pumping, wait for the flow to subside and immediately put a stopper in the upper port. This insures that the grout cannot backflow. Remove the nozzle and put a stopper in the lower inlet port.

If you are doing Pre-Grout sleeves, you can look down inside and see that the sleeve is filled with grout. If the grout is somewhat stiff, use a wire to stir it to remove any entrapped air at the very bottom. Shooting the grout down in the sleeve with the grout pump nozzle is a good alternative to pouring it by hand. It is faster, too.

Q: How do we know the strength of the splice?

A: The performance of the D410 Sleeve-Lock Grout Sleeve is related to the embedment length of the bars and the compressive strength of the grout. As long as the bars meet minimum embedment lengths and the grout meets minimum compressive strengths, the splice will perform as specified.

	<h2 style="text-align: center;">⚠️ WARNING</h2> <h3 style="text-align: center;">Improper Use of Concrete Accessories Can Cause Severe Injury or Death</h3> <p>Read, understand and follow the information and instructions in this publication before using any of the Dayton Superior concrete accessories displayed herein. When in doubt about the proper use or installation of any Dayton Superior concrete accessory, immediately contact the nearest Dayton Superior Service Center or Technical Service Department for clarification.</p>
---	---

Dayton Superior products are intended for use by trained, qualified and experienced workmen only. Misuse or lack of supervision and/or inspection can contribute to serious accidents or deaths. Any application other than those shown in this publication should be carefully tested before use. The user of Dayton Superior products must evaluate the product application, determine the safe working load and control all field conditions to prevent applications of loads in excess of a product's safe working load. Safety factors shown in this publication are approximate minimum values. The data used to develop safe working loads for products displayed in this publication are a combination of actual testing and/or other industry sources. Recommended safe working loads given for the products in this publication must never be exceeded.

---

## Worn Working Parts

For safety, concrete accessories must be properly used and maintained. Concrete accessories shown in this publication may be subject to wear, overloading, corrosion, deformation, intentional alteration and other factors that may affect the device's performance. All reusable accessories must be inspected regularly by the user to determine if they may be used at the rated safe working load or should be removed from service. The frequency of inspections depends upon factors such as (but not limited to) the amount of use, period of service and environment. It is the responsibility of the user to schedule accessory hardware inspections for wear and remove the hardware from service when wear is noted.

---

## Shop or Field Modification

Welding can compromise a product's safe working load value and cause hazardous situations. Knowledge of materials, heat treating and welding procedures is necessary for proper welding. Consult a local welding supply dealer for assistance in determining required welding procedures. Since Dayton Superior cannot control workmanship or conditions in which modifications are done, Dayton Superior cannot be responsible for any product altered in the field.

---

## Interchangeability

Many concrete accessory products that Dayton Superior manufactures are designed as part of a system. Dayton Superior strongly discourages efforts to interchange products supplied by other manufacturers with components supplied by Dayton Superior. When used properly, and in accordance with published instructions, Dayton Superior products have proven to be among the best designed and safest in the industry. Used improperly or with incompatible components supplied by other manufacturers, Dayton Superior products or systems may be rendered unsafe.

---

## Installation

### WARNING

1. Dayton Superior Corporation products shall be installed and used only as indicated on the Dayton Superior Corporation installation guidelines and training materials.
2. Dayton Superior Corporation products must never be used for a purpose other than the purpose for which they were designed or in a manner that exceeds specific load ratings.
3. All instructions are to be completely followed to ensure proper and safe installation and performance.
4. Any improper misuse, misapplication, installation, or other failure to follow Dayton Superior Corporation's instruction may cause product malfunction, property damage, serious bodily injury and death.

### THE CUSTOMER IS RESPONSIBLE FOR THE FOLLOWING:

1. Conformance to all governing codes
2. Use of appropriate industry standard hardware
3. The integrity of structures to which the products are attached, including their capability to safely accept the loads imposed, as evaluated by a qualified engineer.

### SAFETY INSTRUCTIONS:

All governing codes and regulations and those required by the job site must be observed. Always use appropriate safety equipment

---

## Design Changes

Dayton Superior reserves the right to change product designs, rated loads and product dimensions at any time without prior notice.

**Note:** See Safety Notes and Safety Factor Information.



## DAYTON SUPERIOR BRANDS

### CONCRETE ACCESSORIES

Accubrace®  
Aztec®  
Bar Lock®  
Corewall®  
Fleet-Lift™  
Swift Lift®  
Taper-Lock®

### CONSTRUCTION CHEMICALS

Unitex®

### FORMING PRODUCTS

Symons®  
Max-A-Form®  
Steel-Ply®  
Sym-Ply®

## DAYTON SUPERIOR PRODUCTS

### BRIDGE DECK FORMING

Adjustable Joist Hangers  
Bridge Overhang Brackets  
Haunch and Fillet Forming  
Pres-Steel, Coil Rod and Con-Beam  
Hangers  
Screed Supports

### CHEMICALS

Bond Breakers  
Cleaners / Strippers  
Concrete Repair/Restoration  
Curing Compounds / Sealers  
Epoxies  
Floor Levelers  
Form Release Agents  
Grout  
Hardeners / Industrial Toppings  
Liquid Densifiers  
Surface Retarders

### FORMING AND SHORING

Aluminum Shoring  
Ganged Formwork  
Garage Beam System  
Handset Formwork  
Highway Forms  
Jump Forms  
Modular Deck Shoring  
One Sided Frames  
Self Spanning Forms  
Steel Frame Shoring

### FORMLINERS

ABS Plastic  
Polystyrene Plastic

### PAVING

Dowel Bar Expansion Caps  
Dowel Bar Retrofit System  
Elastomeric and Hot Pour Joint Seal  
Metal Keyway Form Systems  
Tie Bar Assemblies  
Transverse Bar Assemblies  
Welded Dowel Assemblies  
Wire Baskets without Dowels

### PRECAST

Anchors and Lift Systems  
Coil / Ferrule Inserts  
Core Plugs  
Magnets  
Precast Forms  
Rustications/Chamfers  
Sandwich Panel Connector  
Shear Connectors  
Slotted Inserts

### REBAR SPLICING

Forged Dowel Bar Couplers  
Lockshear Bolt Couplers  
Shear Resistance Products  
Straight Thread Couplers  
Taper Thread Couplers

### REBAR SUPPORTS

Concrete Dobies  
Continuous Plastic and Steel  
Bar Supports  
Individual Plastic and Steel  
Bar Supports  
Mesh Chairs  
Paving Chairs  
Side Form Spacers

### TIES AND ACCESSORIES

Modular Form Ties  
Single Waler System  
Ties and Accessories

### TILT-UP

Braces and Brace Anchors  
Helical Ground Anchors  
Setting Plugs  
Strongback System  
Tilt-Up Anchors and Lifting Systems

## CONTACT INFORMATION

### CORPORATE HEADQUARTERS

1125 Byers Road  
Miamisburg, OH 45342  
937-866-0711

### ACCESSORIES AND CHEMICALS

Customer Service: 888-977-9600  
Technical Assistance: 877-266-7732  
info@daytonsuperior.com

### FORMING PRODUCTS

Customer Service: 800-800-7966  
Technical Assistance: 877-266-7732  
info@daytonsuperior.com

DS100  
07/13  
\$9.95