

FX_{2N}

FX_{2N}-485-BD

USER'S GUIDE

JY992D74401C

This manual contains text, diagrams and explanations which will guide the reader in the correct installation, safe use and operation of the FX_{2N}-485-BD (hereafter abbreviated to "485BD") and should be read and understood before attempting to install or use the unit. Further information can be found in the associated manuals mentioned below.

Specifications are subject to change without notice

Safety guidelines for the user and protection of the FX_{2N}-485-BD.

This manual has been written to be used by trained and competent personnel. The definition of such a person or persons is as follows:

- Any engineer using the product associated with this manual, should be of a competent nature, trained and qualified to the local and national standards. These engineers should be fully aware of all aspects of safety with regards to automated equipment.
- Any commissioning or service engineer must be of a competent nature, trained and qualified to the local and national standards.
- All operators of the completed equipment should be trained to use this product in a safe and coordinated manner in compliance to established safety practices.

Note: The term 'completed equipment' refers to a third party constructed device which contains or uses the product associated with this manual.

Notes on the Symbols Used in this Manual

At various times throughout this manual certain symbols will be used to highlight points of information which are intended to ensure the users personal safety and protect the integrity of equipment.



- 1) Indicates that the identified danger **WILL** cause physical and property damage.



- 2) Indicates that the identified danger could **POSSIBLY** cause physical and property damage.

- Under no circumstances will Mitsubishi Electric be liable or responsible for any consequential damage that may arise as a result of the installation or use of this equipment.
- All examples and diagrams shown in this manual are intended only as an aid to understanding the text, not to guarantee operation. Mitsubishi Electric will accept no responsibility for the actual use of the product based on these illustrative examples.
- Please contact a Mitsubishi distributor for more information concerning applications in life critical situations or high reliability.

Associated Manuals

PROGRAMMING MANUAL, PROGRAMMING MANUAL II, or FX COMMUNICATION USER'S MANUAL mentioned below are not provided in sets with a product.

Contact our agent where the product was purchased to request the manuals accordingly.

	Manual Name	Manual Number	Description
★	FX COMMUNICATION USER'S MANUAL	JY992D69901	Describes contents related to communication available in FX Series PLC such as wiring, communication setting, and program examples.
★	FX _{2N} HARDWARE MANUAL	JY992D66301	Describes contents related to hardware of FX _{2N} Series PLC such as specifications, wiring, and installation.
★	PROGRAMMING MANUAL II	JY992D88101	Describes contents related to instruction in FX _{1S} /FX _{1N} /FX _{2N} /FX _{2NC} Series PLC.

★ Indispensable manual

This manual describes the installation the and specifications of the 485BD.
 For details on wiring (including use of terminal resistor and preparation of cable) with communication equipment, system configuration and communication setting, and program examples, refer to the "FX COMMUNICATION USER'S MANUAL".

1. Outline of Product

The 485BD is an insulated RS-485 communication board with an European type terminal block. Connected to the main unit of the FX2N Series PLC, it enables signal exchange between the PLC and equipment via an RS-485 port.

1.1 Communication Functions and Applicable PLC (Available in indicated version or later)

Communication type	FX2N	Function
N:N network	V2.00	Data transfer connecting up to eight FX Series PLCs.
Parallel link	V1.04	Data transfer between two PLCs relationship specifying master/slave station.
Computer link	V1.06	Data transfer via link protocol between PLC and computer (specified as the master station).
No protocol communication	V1.06	Serial communication without protocol between PLC and equipment via RS-485 interface.
Inverter communication	V3.00	Controlling Mitsubishi's FREQROL inverter using EXTR instruction in function expansion memory.

1.2 Outside dimensions and name of each part

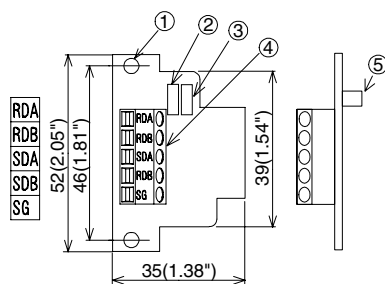

Unit: mm (inches)

Accessories: Terminal resistor 330Ω 2
Terminal resistor 110Ω 1
M3 screw to mount board 2
Station No. label for link

- ① Mounting hole (2-φ3.5)
- ② Terminal block for RS-485 equipment
The top face of this terminal box is higher than the top face of the PLC panel cover by approximately 7 mm (0.27").
- ③ SD LED: Flickers at high speed during send.
- ④ RD LED: Flickers at high speed during receive.
- ⑤ Connector for PLC

Recommended screwdriver to tighten terminal screws

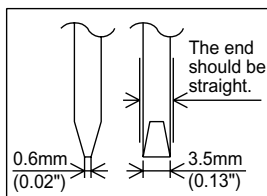

1.3 System configuration

Only one function expansion board can be used for one main unit of FX2N. FX2N-485-BD cannot be used by the plural. Other expansion boards cannot be used together with FX2N-485-BD. For the system configuration, refer to the FX Series Communication User's Manual offered separately.

2. Installation



Caution

- Use in the environments specified under the general specification in the manual. Do not use the product in environments with excessive or conductive dust, corrosive or flammable gas, oily smoke, moisture or rain, excessive heat, regular impact shocks or excessive vibration, as it may result in electrical shock, fire, malfunction, damage or deterioration on the product.
- Make sure to shut off the power outside the product before installing or wiring it. Otherwise, electric shock or serious damage to on the product may occur.
- Never drop wire chips or shavings into the vent slits when drilling screw holes or performing wiring, as they may cause fire, breakdown, or malfunction.

Securely install the 485BD to the designated port.
Poor connection may cause malfunction.

2.1 Installation procedure

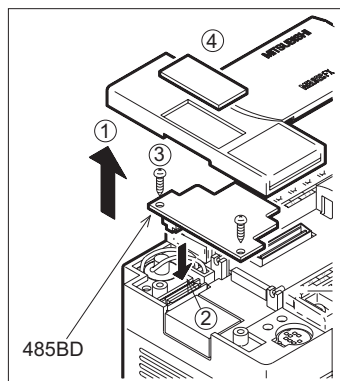

Turn off the power of the programmable controller, and mount the 485BD using the following procedure.

- ① Remove the panel cover from the top face of the base unit.
- ② Connect the connector for programmable controller provided on the 485BD to the board mounting connector provided on the base unit.
- ③ Fix the 485BD to the base unit using the M3 self-tapping screws supplied. Tightening torque: 0.3 to 0.6 N·m
- ④ Remove the cut out on the left of the panel cover using a tool such as nippers or cutters so that the terminal block is accessible. The top face of this terminal block is higher than the top face of the panel cover of the programmable controller by approximately 7 mm (0.27").

3. Specifications

3.1 Environmental specifications

The environmental specifications are equivalent to those of the PLC main unit.
(Refer to the manual of the PLC main unit.)

3.2 Power supply specifications

5V DC, 60 mA is supplied as the power from the PLC.

3.3 Performance specifications

Item	Description
Transmission standard	In conformance to RS-485 and RS-422
Maximum transmission distance	50m (164ft) maximum
Communication type	No protocol communication, Computer link (dedicated protocol), parallel link, N:N network
Communication method	Full-duplex (When the version of PLC(FX2N) is Ver. 2.00 or later) / Half-duplex (When the version of PLC(FX2N) is earlier than Ver. 2.00)
Communication procedure	No protocol communication, Computer link (dedicated protocol 1, dedicated protocol 4), parallel link, N:N network
Transmission speed (baud rate)	No protocol communication, Computer link (dedicated protocol): 300/600/1200/2400/4800/9600/19200 (bps) Parallel link: 19200(bps) N:N network: 38400(bps)
Insulation	None

Manual number: JY992D74401

Manual revision: C

Date : SEPTEMBER 2003

FX_{2N}

FX_{2N}-485-BD

USER'S GUIDE

JY992D74401C

This manual contains text, diagrams and explanations which will guide the reader in the correct installation, safe use and operation of the FX_{2N}-485-BD (hereafter abbreviated to "485BD") and should be read and understood before attempting to install or use the unit. Further information can be found in the associated manuals mentioned below. Specifications are subject to change without notice.

Safety guidelines for the user and protection of the FX_{2N}-485-BD.

This manual has been written to be used by trained and competent personnel. The definition of such a person or persons is as follows:

- Any engineer using the product associated with this manual, should be of a competent nature, trained and qualified to the local and national standards. These engineers should be fully aware of all aspects of safety with regards to automated equipment.
- Any commissioning or service engineer must be of a competent nature, trained and qualified to the local and national standards.
- All operators of the completed equipment should be trained to use this product in a safe and coordinated manner in compliance to established safety practices.

Note: The term 'completed equipment' refers to a third party constructed device which contains or uses the product associated with this manual.

Notes on the Symbols Used in this Manual

At various times throughout this manual certain symbols will be used to highlight points of information which are intended to ensure the user personal safety and protect the integrity of equipment.



- Indicates that the identified danger **WILL** cause physical and property damage.



- Indicates that the identified danger could **POSSIBLY** cause physical and property damage.

- Under no circumstances will Mitsubishi Electric be liable or responsible for any consequential damage that may arise as a result of the installation or use of this equipment.
- All examples and diagrams shown in this manual are intended only as an aid to understanding the text, not to guarantee operation. Mitsubishi Electric will accept no responsibility for the actual use of the product based on these illustrative examples.
- Please contact a Mitsubishi distributor for more information concerning applications in life critical situations or high reliability.

Associated Manuals

PROGRAMMING MANUAL, PROGRAMMING MANUAL II, or FX COMMUNICATION USER'S MANUAL mentioned above are not provided in sets with a product.

Contact our agent where the product was purchased to request the manuals accordingly.

	Manual Name	Manual Number	Description
★	FX COMMUNICATION USER'S MANUAL	JY992D69901	Describes contents related to communication available in FX Series PLC such as wiring, communication setting, and program examples.
★	FX _{2N} HARDWARE MANUAL	JY992D66301	Describes contents related to hardware of FX _{2N} Series PLC such as specifications, wiring, and installation.
★	PROGRAMMING MANUAL II	JY992D88101	Describes contents related to instruction in FX _{1S} /FX _{1N} /FX _{2N} /FX _{2NC} Series PLC.

★ Indispensable manual

This manual describes the installation and specifications of the 485BD. For details on wiring (including use of terminal resistor and preparation of cable) with communication equipment, system configuration and communication setting, and program examples, refer to the "FX COMMUNICATION USER'S MANUAL".

1. Outline of Product

The 485BD is an insulated RS-485 communication board with an European type terminal block. Connected to the main unit of the FX_{2N} Series PLC, it enables signal exchange between the PLC and equipment via an RS-485 port.

1.1 Communication Functions and Applicable PLC (Available in indicated version or later)

Communication type	FX _{2N}	Function
N:N network	V2.00	Data transfer connecting up to eight FX Series PLCs.
Parallel link	V1.04	Data transfer between two PLCs relationship specifying master/slave station.
Computer link	V1.06	Data transfer via link protocol between PLC and computer (specified as the master station).
No protocol communication	V1.06	Serial communication without protocol between PLC and equipment via RS-485 interface.
Inverter communication	V3.00	Controlling Mitsubishi's FREQROL inverter using EXTR instruction in function expansion memory.

1.2 Outside dimensions and name of each part

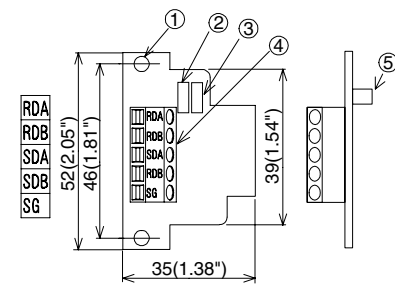

Unit: mm (inches)

Accessories: Terminal resistor 330Ω 2
Terminal resistor 110Ω 1
M3 screw to mount board 2
Station No. label for link

- Mounting hole (2-φ3.5)
- Terminal block for RS-485 equipment
The top face of this terminal box is higher than the top face of the PLC panel cover by approximately 7 mm (0.27").
- SD LED: Flickers at high speed during send.
- RD LED: Flickers at high speed during receive.
- Connector for PLC

Recommended screwdriver to tighten terminal screws

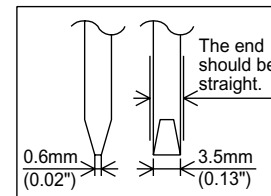

1.3 System configuration

Only one function expansion board can be used for one main unit of FX_{2N}. FX_{2N}-485-BD cannot be used by the plural. Other expansion boards cannot be used together with FX_{2N}-485-BD. For the system configuration, refer to the FX Series Communication User's Manual offered separately.

2. Installation



Caution

- Use in the environments specified under the general specification in the manual. Do not use the product in environments with excessive or conductive dust, corrosive or flammable gas, oily smoke, moisture or rain, excessive heat, regular impact shocks or excessive vibration, as it may result in electrical shock, fire, malfunction, damage or deterioration on the product.
- Make sure to shut off the power outside the product before installing or wiring it. Otherwise, electric shock or serious damage to on the product may occur.
- Never drop wire chips or shavings into the vent slits when drilling screw holes or performing wiring, as they may cause fire, breakdown, or malfunction.

Securely install the 485BD to the designated port. Poor connection may cause malfunction.

2.1 Installation procedure

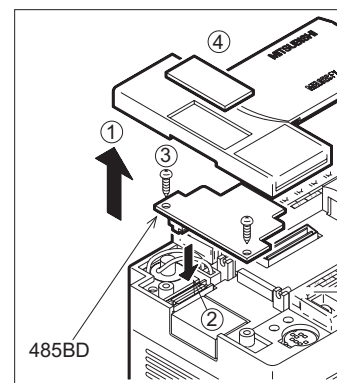

Turn off the power of the programmable controller, and mount the 485BD using the following procedure.

- Remove the panel cover from the top face of the base unit.
- Connect the connector for programmable controller provided on the 485BD to the board mounting connector provided on the base unit.
- Fix the 485BD to the base unit using the M3 self-tapping screws supplied. Tightening torque: 0.3 to 0.6 N·m
- Remove the cut out on the left of the panel cover using a tool such as nippers or cutters so that the terminal block is accessible. The top face of this terminal block is higher than the top face of the panel cover of the programmable controller by approximately 7 mm (0.27").

3. Specifications

3.1 Environmental specifications

The environmental specifications are equivalent to those of the PLC main unit. (Refer to the manual of the PLC main unit.)

3.2 Power supply specifications

5V DC, 60 mA is supplied as the power from the PLC.

3.3 Performance specifications

Item	Description
Transmission standard	In conformance to RS-485 and RS-422
Maximum transmission distance	50m (164ft) maximum
Communication type	No protocol communication, Computer link (dedicated protocol), parallel link, N:N network
Communication method	Full-duplex (When the version of PLC(FX _{2N}) is Ver. 2.00 or later) / Half-duplex (When the version of PLC(FX _{2N}) is earlier than Ver. 2.00)
Communication procedure	No protocol communication, Computer link (dedicated protocol 1, dedicated protocol 4), parallel link, N:N network
Transmission speed (baud rate)	No protocol communication, Computer link (dedicated protocol): 300/600/1200/2400/4800/9600/19200 (bps) Parallel link: 19200(bps) N:N network: 38400(bps)
Insulation	None

Manual number : JY992D74401

Manual revision : C

Date : SEPTEMBER 2003