

Q-Spot™
250W EHJ Intelligent Moving Yoke

Q-Spot™ 150
150W HTI Intelligent Moving Yoke

USER MANUAL

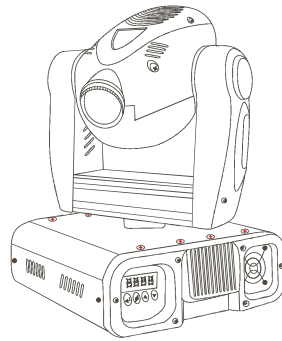

CHAUVET, 3000 N 29th Ct, Hollywood, FL 33020 U.S.A
(800) 762-1084 – (954) 929-1115
FAX (954) 929-5560
www.chauvetlighting.com

Table of Content

BEFORE YOU BEGIN.....	3
WHAT IS INCLUDED	3
UNPACKING INSTRUCTIONS.....	3
AC POWER	3
SAFETY INSTRUCTIONS.....	3
INTRODUCTION	4
TECHNICAL FEATURES.....	4
FEATURES.....	4
FOREWORD.....	4
DMX CHANNEL SUMMARY	5
PRODUCT OVERVIEW.....	6
SETUP	7
LAMP.....	7
Lamp Installation	7
Lamp Alignment How-To.....	7
POWER	8
EXCHANGING GOBOS.....	8
MOUNTING	9
OPERATING INSTRUCTIONS.....	10
CONTROL PANEL.....	10
CONTROL PANEL FUNCTIONS.....	10
APPLYING CHANGES TO FUNCTIONS (QUICK INSTRUCTIONS)	10
OPERATING MODES.....	11
Master/Stand Alone.....	11
Setting Slave Fixtures	11
DMX Mode.....	12
Daisy Chain Connection.....	12
MENU FUNCTIONS	12
DMX-512 addressing.....	12
Setting the starting address	12
User Configurations	13
(P1-y) – 16 bit Control	13
Default (P1-n) & P3 – 8 bit Control.....	13
P-4 – {Function reserved and not in use}.....	13
P5 - Pan Invert / P6- Tilt Invert.....	13
Segment Display Configurations	14
PC - Display Invert	14
Service Functions	14
P7 - Fixture Reset (all motors)	14
Pb - Fixture Partial Reset (excludes Pan & Tilt)	14
H000 - Fixture Hours	14
Resetting Fixture Hours.....	14
APPENDIX	15
DMX PRIMER.....	15
Fixture Linking	15
DMX CHANNEL VALUES (16 BIT)	16
MAINTENANCE.....	17
RETURNS PROCEDURE	17
CLAIMS	17
GENERAL TROUBLESHOOTING	18
TECHNICAL SPECIFICATIONS.....	19

BEFORE YOU BEGIN

What is included

- Q-Spot™ & EHJ lamp
- or
- Q-Spot™ 150 & HTI150 lamp
- Power cord with plug
- Manual
- Warranty Card

Unpacking Instructions

Immediately upon receiving a fixture, carefully unpack the carton, check the contents to ensure that all parts are present, and have been received in good condition. Notify the shipper immediately and retain packing material for inspection if any parts appear damaged from shipping or the carton itself shows signs of mishandling. Save the carton and all packing materials. In the event that a fixture must be returned to the factory, it is important that the fixture be returned in the original factory box and packing.

AC Power

To determine the power requirements for a particular fixture, see the label affixed to the back plate of the fixture or refer to the fixture's specifications chart. A fixture's listed current rating is its average current draw under normal conditions. All fixtures must be powered directly off a switched circuit and cannot be run off a rheostat (variable resistor) or dimmer circuit, even if the rheostat or dimmer channel is used solely for a 0% to 100% switch. Before applying power to a fixture, check that the source voltage matches the fixture's requirement. Check the fixture or device carefully to make sure that if a voltage selection switch exists that it is set to the correct line voltage you will use.

Figure 1 - AC Voltage Switch



Warning!

Verify that the power select switch on your unit matches the line voltage applied. All fixtures must be connected to circuits with a suitable Earth Ground.

Safety Instructions



Please read these instructions carefully, which includes important information about the installation, usage and maintenance?



- Please keep this User Guide for future consultation. If you sell the unit to another user, be sure that they also receive this instruction booklet.
- Always make sure that you are connecting to the proper voltage and that the line voltage you are connecting to is not higher than that stated on decal or rear panel of the fixture.
- This product is intended for indoor use only!
- To prevent risk of fire or shock, do not expose fixture to rain or moisture. Make sure there are no flammable materials close to the unit while operating.
- The unit must be installed in a location with adequate ventilation, at least 50cm from adjacent surfaces. Be sure that no ventilation slots are blocked.
- Always disconnect from power source before servicing or replacing lamp or fuse and be sure to replace with same lamp source.
- Secure fixture to fastening device using a safety chain. Never carry the fixture solely by its head. Use its carrying handles.
- Maximum ambient temperature is $T_a: 40^\circ$. Do not operate fixture at temperatures higher than this.
- In the event of serious operating problem, stop using the unit immediately. Never try to repair the unit by yourself. Repairs carried out by unskilled people can lead to damage or malfunction. Please contact the nearest authorized technical assistance center. Always use the same type spare parts.
- Don't connect the device to a dimmer pack.
- Make sure power cord is never crimped or damaged.
- Never disconnect power cord by pulling or tugging on the cord.
- Avoid direct eye exposure to lamp while it is on.

Caution!

There are no user serviceable parts inside the unit. Do not open the housing or attempt any repairs yourself. In the unlikely event your unit may require service, please contact CHAUVET.

INTRODUCTION

Technical Features

- 6-9 channel DMX Intelligent Scanner
- Pan: 540°
- Tilt: 270°
- Pan/Tilt speed & reset control channel
- Mechanical Dimmer/Shutter/Strobe
- Rotating Gobos
 - 7 interchangeable rotating gobos
 - 5 metal, 2 glass
 - Gobo Bounce™
 - Gobo wheel spin
 - in both directions, at variable speeds
- Color Wheel
 - 9 colors plus open
 - Rainbow color spin
 - in both directions, at variable speeds
- Gobo rotation control channel

Features

- Automatic Pan/Tilt correction
- Built in beat activated and automatic programs (stand-alone)
- User selectable 8 or 16 bit movement resolution
- LED display menu with invert
- Pan/Tilt Invert option
- Micro-stepping motors
- Thermal switch

Foreword

Both the Q-Spot™ and the Q-Spot™ 150 fixtures are identical in electromechanical effects and control. The main difference lies in the lamp each product uses.

The Q-Spot™ 150 utilizes the HTI® 150 High Intensity Discharge lamp source. This is a modern lamp technology that provides higher color temperature of the light beam, at 6,500°Kelvin, longer lamp life and lower power consumption at only 150 watts. This color is considered true white, also known as daylight.

The Q-Spot™ uses the ever popular EHJ halogen lamp. It is a powerful and economical lamp. At 250 watts it provides just over of the same intensity measured in lumens as the HTI® 150 though at the expense of shorter life. However, the EHJ is a much more economical purchase than the HTI® 150. Both lamps are well suited for the job.

Brief Lamp specifications

LAMP	LUMENS	LIFE
HTI® 150	9,500	750 hrs
EHJ	10,000	50 hrs

DMX Channel Summary

There are 4 fixture DMX personality configurations in both fixtures. These settings are user selectable using the control panel interface.

Default Setting = P1-n P2-n P3-n

CHANNEL	FUNCTION	CHANNEL	FUNCTION
1	Pan	4	Gobo
2	Tilt	5	Color
3	Shutter/Dimmer	6	Gobo Rotation

Setting = P1-4 P2-n P3-n

CHANNEL	FUNCTION	CHANNEL	FUNCTION
1	Pan	6	Shutter/Dimmer
2	Tilt	7	Gobo
3	Pan (Fine)	8	Color
4	Tilt (Fine)	9	Gobo Rotation
5	Pan/Tilt Speed		

Setting = P1-n P2-4 P3-n

CHANNEL	FUNCTION	CHANNEL	FUNCTION
1	Pan	6	Shutter/Dimmer
2	Pan (Fine)	7	Gobo
3	Tilt	8	Color
4	Tilt (Fine)	9	Gobo Rotation
5	Pan/Tilt Speed		

Setting = P1-n P2-n P3-4

CHANNEL	FUNCTION	CHANNEL	FUNCTION
1	Pan	5	Gobo
2	Tilt	6	Color
3	Pan/Tilt Speed	7	Gobo Rotation
4	Shutter/Dimmer		

Product Overview

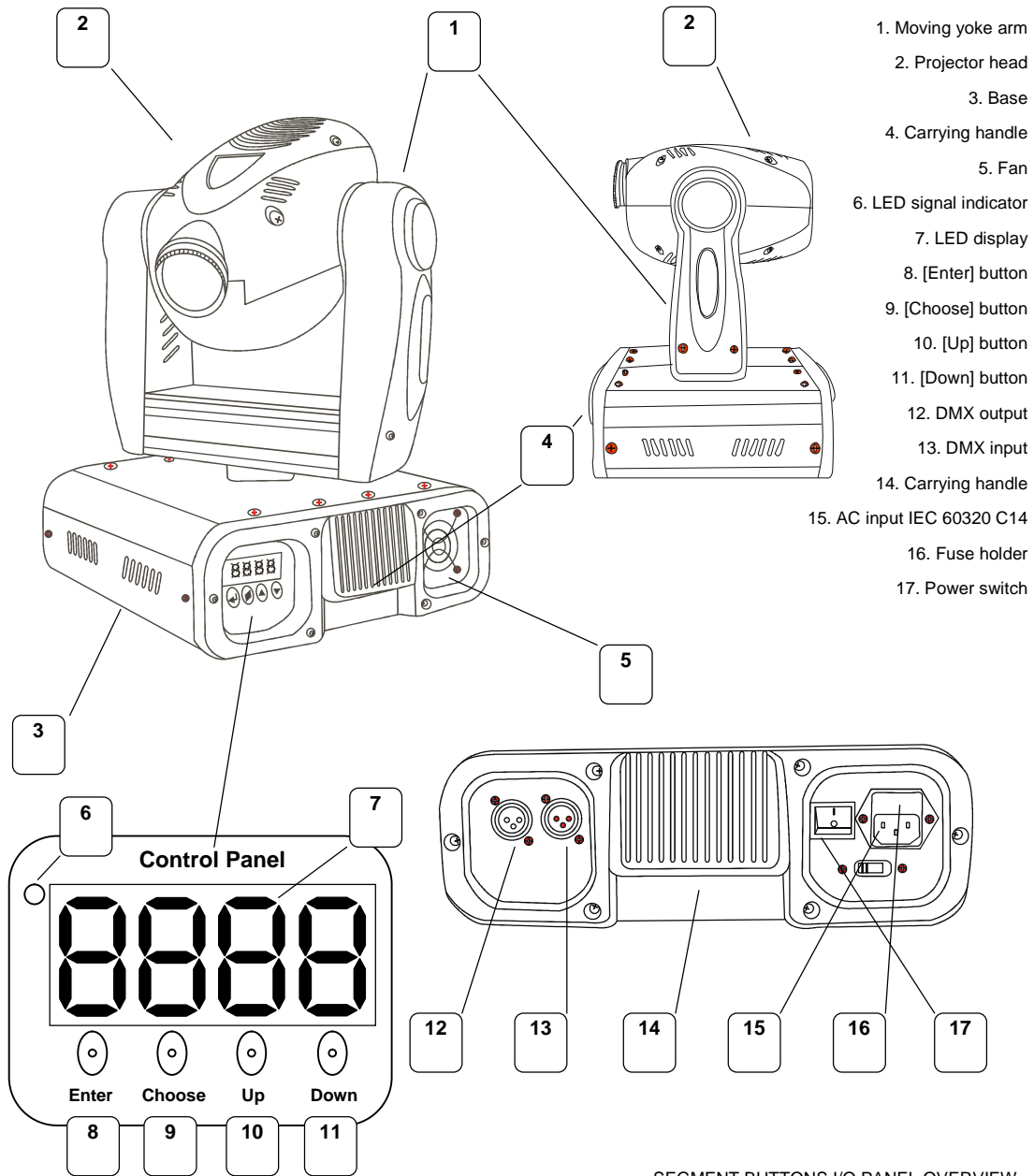

- 1. Moving yoke arm
- 2. Projector head
- 3. Base
- 4. Carrying handle
- 5. Fan
- 6. LED signal indicator
- 7. LED display
- 8. [Enter] button
- 9. [Choose] button
- 10. [Up] button
- 11. [Down] button
- 12. DMX output
- 13. DMX input
- 14. Carrying handle
- 15. AC input IEC 60320 C14
- 16. Fuse holder
- 17. Power switch

SEGMENT BUTTONS I/O PANEL OVERVIEW

BUTTONS		I/O PANEL	
Choose	Toggles programming functions	DMX Out & In	DMX-512 connectors
Down	Steps backward through menu functions	Power	AC input IEC 60320 C14 and fuse holder
Up	Steps forward through menu functions		
Enter	Confirms selected menu function		

SETUP

Lamp

You will need to install a lamp prior to the initial operation of the fixture. Depending on your particular unit, either a HTI150 high intensity discharge lamp or an EHJ halogen lamp is included.

Warning! *When replacing the lamp, please wait 15 minutes after powering down to allow the unit to cool down! Always disconnect from main power prior to lamp replacement.*

Do not touch the envelope (glass area) of the bulb with bare hands. If this happens, clean the lamp with alcohol and wipe it with a lint free cloth before installation.

Lamp Installation

1. Remove screws labeled (S1) and pull out lamp socket plate.
2. If replacing the lamp, remove old lamp first.
3. Holding the new lamp by its base, align the pins on the lamp with the small hole in the socket and insert the lamp squarely until the retaining clips on the lamp socket secure the lamp tightly.
4. Clean the glass/envelope of the bulb with an alcohol wipe or equivalent.
5. Holding the lamp socket plate, insert the tip of the lamp into the fixture with extreme care. Navigate the lamp all the way until it reaches the reflector and the lamp base plate touches the bottom plate of the fixture.
6. Align the screw holes and fasten the screws back onto the lamp socket plate.
7. If you are replacing the lamp, you may want to log the fixture hours in order to track the lamps use. Navigate to the H000 on the menu display to obtain this information.
8. Turn the fixture on and adjust the lamp alignment screws (S2) until the brightest most even area of the beam is in the center of your spot. It may be necessary for you to use a controller in order to command the fixture to display a white beam on a flat surface with no colors.

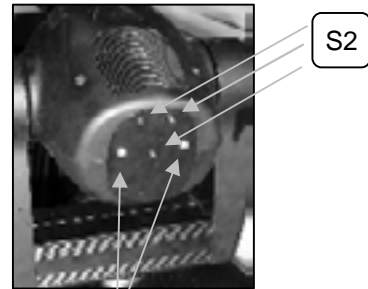

Maximizing the life of your lamp

To ensure the longest and most efficient use of the lamp always wait between 10 and 15 minutes before re-applying power after a shutdown.

Failure to do so could result in premature aging of the lamp and failure to the electronics that drive it.

Lamp Alignment How-To

Often, after a new installation of a lamp, you will find that there is an uneven field of light or what is referred to as a hot spot. This is due to the most intense point of the lamp source not being positioned optimally within the reflector.

There are three lamp alignment screws provided at the base of the projector head. Turning these screws allow you to optimize the projection quality of the spot as well as the overall intensity of the beam.

1. Project a white spot against any flat surface. Preferably the surface should be white or pastel in color.
2. Turning the lamp alignment screws, try to position the hot spot in the center of the beam as best as possible. This could require many attempts on your part.
3. Once the hot spot is in the center of the spot, do your best to turn all screws equally as to affect movement up or down within the reflector.
4. As you move in and out of optimum lamp focus, you will see the hot spot either gets wider or narrower. The goal is to either totally diminish the hot spot by having it widen and spread across the entire spot or moving the hot spot so that it covers as much of the beam spot area as possible.

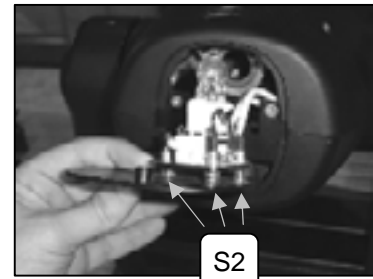

Lamp Alignment Screws

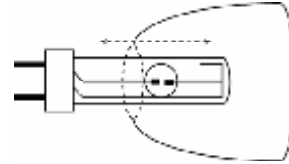

Power

Your product is equipped with switch-selectable AC power setting.

Warning!

Verify that the power select switch on your unit matches the line voltage applied. All fixtures must be connected to circuits with a suitable Earth Ground.

Slide switch up or down depending on your line voltage.



- To determine the power requirements for a particular fixture, see the label affixed to the back plate of the fixture or refer to the fixture's specifications chart.
- A fixture's listed current rating is its average current draw under normal conditions.
- All fixtures must be powered directly off a switched circuit and cannot be run off a rheostat (variable resistor) or dimmer circuit, even if the rheostat or dimmer channel is used solely for a 0% to 100% switch.
- Before applying power to a fixture, check that the source voltage matches the fixture's requirement.
- All fixtures must be connected to circuits with a suitable Earth Ground.

Power Cable Configuration

CABLE	PIN	INTERNATIONAL
BROWN	Live	L
BLUE	Neutral	N
YELLOW/GREEN	Earth	EG (Ground)

Exchanging gobos

1. Press both tips of the gobo tension ring together and remove from aperture.
2. Push the gobo with your finger from the back side following the same direction that the tension ring was removed.



Mounting

Orientation

Both fixtures can sit on stage or be mounted on a truss using a clamp in any position, provided, there is adequate room for ventilation.

Warning

It is important never to obstruct the fan or vents pathway.

- When selecting installation location, take into consideration lamp replacement access and routine maintenance.
- Safety cables should always be used.
- Never mount in places where the fixture will be exposed to rain, high humidity, extreme temperature changes or restricted ventilation.
- The fixture must have a minimum of 1 meter distance from combustible materials.

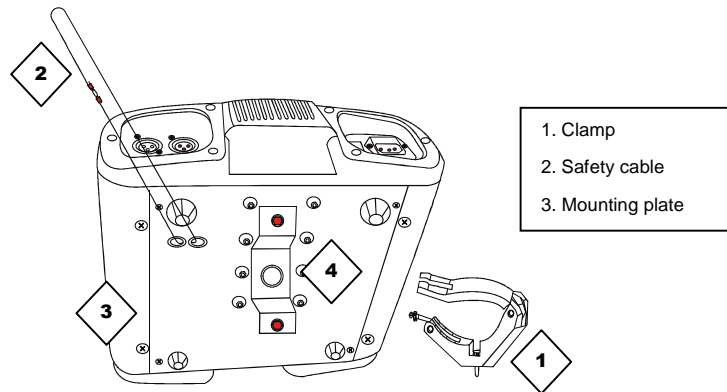

Rigging

Both fixtures include a mounting plate to which a bracket and 1 rigging clamp can be bolted.

1. Align the mounting bracket with the screws at the bottom of the base, insert screws and tighten.
2. Verify the structure can hold 10 times the weight of all to-be installed fixtures.
3. From a stable platform, attach a clamp to the bracket. Depending on your particular clamp, it may be necessary to attach clamp to bracket before mounting bracket to plate.

OPERATING INSTRUCTIONS

Control Panel

On the control panel you can set the DMX address, set the fixture to Master/Slave mode, reset the fixture and change fixture personality trait.

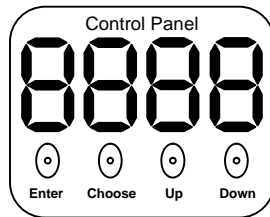

[Enter] Confirms selection

[Choose] Access to main menu

[Up] Toggle menu items in a forward direction

[Down] Toggle menu items in a reverse direction

Control Panel Functions

FUNCTION	OPTIONS	NOTES
P1	-n -y	Default Personality (6ch) 16 bit Personality (9ch)
P2	-y/-n	16 bit Personality Alternate (9ch)
P3	-y/-n	8 bit Personality with Speed Control (7ch)
P4	-	Function reserved
P5	-y/-n	Pan invert
P6	-y/-n	Tilt invert
P7	-y/-n	Fixture reset
P8	-y/-n	Activate music trigger
P9	-y/-n	Stand Alone mode
PA	-y/-n	Master/Slave mode
Pb	-y/-n	Reset all functions except Pan & Tilt
Pc	-y/-n	Display invert
RD01	000-512	DMX channel addressing
HD00	001-999	Displays fixture hours

-y: Activates setting

-n: Disables, skips or selects alternative setting

Applying changes to Functions (Quick Instructions)

Unless other wise stated changes in the control panel can be applied in the following manner.

1. Press [Choose] button repeatedly until the display reads the menu function you wish to change as illustrated in the table above in section "Control Panel Functions"
2. The display will read the previously stored settings for the desired function, for example, either with a "-y" or a "-n" as in "PA-y or PA-n".
3. Press the [Up] or [Down] button to toggle between either the "-y" or "-n" selection for that particular menu function.
4. Press the [Enter] button to store your selection. The display will read "PASS" to confirm your selection

Operating Modes

- A stand-alone mode will listen to sound and run through its diverse range of built in programs.
- Master/Slave mode will allow the command of up to as many units you want in a synchronized light show to the sound.
- DMX control mode will provide the greatest flexibility and creativity. Each fixture trait can be controlled individually using any universal DMX-512 controller.

Master/Stand Alone

In order to create the correct environment for Stand Alone operation, several parameters have to be set in the control panel. Please make the changes to the functions as listed in the table below.

FUNCTION	SET TO	NOTES
PA	-y	Master mode
P8	-y	Sound activated
P9	-y	Run built-in programs
A	001	Channel address
P5	Any	Pan invert
P6	Any	Tilt invert

Note!

If the fixture is connected to a controller, please disconnect it.

The display will read the previously selected setting.

Only one fixture can be the Master assigned fixture. However, 16 units can be slaved to the master unit.

At this stage it is important to notate the following function settings for the Master fixture. It will be necessary to duplicate these in Slave fixtures.

Master Fixture Settings	
Function	Notate Setting
P1	
P2	
P3	

Setting Slave Fixtures

The Master/Slave mode will allow you to link multiple units in a daisy chain fashion. In this mode, the first unit in the daisy chain, the master, will automatically command all other units following. The first unit will operate in a Stand/Alone mode and all units following will synchronize to the first unit. Up to 16 fixtures can be daisy chained in Master/Slave mode.

MENU	SET TO	NOTES
PA	-n	Master mode
P8	-n	Sound activated
P9	-n	Run built-in programs
A	001	Channel address
P1		Carry over settings from Master Unit
P2		Carry over settings from Master Unit
P3		Carry over settings from Master Unit
P5	Any	Pan invert
P6	Any	Tilt invert

Important!

P1, P2, and P3 must be set identically to the Master unit in order for the Master/Slave mode to function properly.

You can change the Pan and Tilt Invert settings freely.

DMX Mode

Operating in a DMX Control mode environment gives the user the greatest flexibility when it comes to customizing or creating a show. You can tailor your programming to suit a specific event. Whether it is a wedding where a spot light may be required or a lead singer requiring a color solo, the opportunities are endless. In this mode you will be able to control each individual trait of the fixture independently.

Daisy Chain Connection

1. Connect the (male) 3 pin connector side of the DMX cable to the output (female) 3 pin connector of the first fixture.
2. Connect the end of the cable coming from the first fixture which will have a (female) 3 pin connector to the input connector of the next fixture consisting of a (male) 3 pin connector. Then, proceed to connect from the output as stated above to the input of the following fixture and so on.

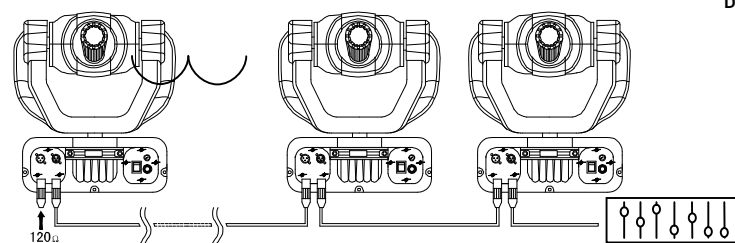

Menu Functions

DMX-512 addressing

This mode enables the use of a universal DMX controller device. Each fixture requires a "start address" from 1 to 511. A fixture requiring one or more channels for control begins to read the data on the channel indicated by the start address. For example, a fixture that occupies or uses 6 channels of DMX and was addressed to start on DMX channel 100, would read data from channels: 100, 101, 102, 103, 104, and 105. Choose start addresses so that the channels used do not overlap and notate the start address selected for future reference.

If this is your first time addressing a fixture using the DMX-512 control protocol than I suggest jumping to the Appendix Section and read the heading "DMX Primer". It contains very useful information that will help you understand its use.

Setting the starting address

1. Press the **[Choose]** button until the display reads "ANNN" where N represents a number from 0 to 9.
2. Press the **[Up]** and **[Down]** buttons to increase or decrease values until the desired value is achieved.
3. Press the **[Enter]** button to activate selection.

User Configurations

(P1-y) – 16 bit Control

In the 16 bit Control Channel mode you gain a higher degree of resolution in both Pan and Tilt movement. One extra channel for both the Pan and the Tilt are added and they perform as the “Fine” movement.

The primary Pan or Tilt channel is known as the MSB “Most Significant Bit”. This is the channel that controls the course or broader range of movement. On a DMX signal stream, there are 255 values for one channel.

The “Fine” Pan or Tilt channel is known as the LSB “Least Significant Bit”. This channel gives you control of the space between any two MSB values. In other words, it increases the resolution of both the Pan and Tilt movement, by providing the control of 255 additional values in between each Primary channel value.

FUNCTION	SET TO	DESCRIPTION	NOTES
P1	-y	16 bit Control	Hi resolution mode
P2	-n	16 bit Control (Alternate)	
P3	-n	8 bit Control with Speed	

FUNCTION	SET TO	DESCRIPTION	NOTES
P1	-n	8 bit Control	
P2	-y	16 bit Control (Alternate)	Fine (LSB) channels are swapped. 1- Pan / 2-Pan (Fine) / 3-Tilt / 4-Tilt (Fine)
P3	-n	8 bit Control with Speed	

Default (P1-n) & P3 – 8 bit Control

In 8 bit Control Channel mode Pan and Tilt are controlled using the (MSB) method only.

FUNCTION	SET TO	NOTES	NOTES
P1	-n	8 bit Control Channel	This is the default setting for the unit
P2	-n	16 bit Control (Alternate)	
P3	-n	8 bit Control with Speed	

FUNCTION	SET TO	NOTES	NOTES
P1	-n	16 bit Control Channel	Pan/Tilt (Fine) channels are removed and Speed Control of Pan & Tilt is added (vector)
P2	-n	8 bit Control Channel	
P3	-y	8 bit Control with Speed Ch	

P-4 – {Function reserved and not in use}

P5 - Pan Invert / P6- Tilt Invert

It is possible to invert the pan and tilt mirror movement from within the fixture itself. This could be helpful in situations where the positioning or rigging of a fixture led to a reverse orientation of the fixture in relation to all or most other fixtures installed. When choosing to command the pan or tilt of all fixtures at the same time you will notice that the fixtures whose orientation is different from the others will most likely move opposite of the rest. You can apply a pan and tilt Invert by following the settings in the table below.

FUNCTION	SET TO	NOTES
P5	-y	Pan Invert
P6	-y	Tilt Invert
P5 & P6	-n	Return to normal

Segment Display Configurations

The display can be inverted making it easier to read the menu depending on the orientation of your fixture.

PC - Display Invert

FUNCTION	SET TO	NOTES
PC	-y	Invert display
PC	-n	Return to normal

Service Functions

P7 - Fixture Reset (all motors)

This function will re-initialize the fixture by returning all motors to its startup positions or otherwise known as (home position).

FUNCTION	SET TO	NOTES
P7	-y	Reset fixture
P7	-n	Skip function

Pb - Fixture Partial Reset (excludes Pan & Tilt)

This function will re-initialize the fixture with exception of the Pan and Tilt motors.

FUNCTION	SET TO	NOTES
Pb	-y	Reset fixture, excluding Pan & Tilt
Pb	-n	Skip function

H000 - Fixture Hours

The (fixture hours) readout displays the number of hours the fixture has been in use. It is not uncommon to find new fixtures with a few logged hours. This means the fixture was thoroughly tested prior to delivery.

1. Press the **[Choose]** button until the display reads "HNNN" where N represents a number from 0 to 9.
2. The numbers represented are the hours of operation since last counter-reset.

Resetting Fixture Hours

1. Press the **[Choose]** button until the display reads "- - - -".
2. Press and hold the **[Enter]** button.
3. Press the **[Up]** button then the **[Down]** button.
4. Action is confirmed by a "dEFA" on the read out display, followed by a fixture reset.

APPENDIX

DMX Primer

There are 512 channels in a DMX-512 connection. Channels may be assigned in any manner. A fixture capable of receiving DMX-512 will require one or a number of sequential channels. The user must assign a starting address on the fixture that indicates the first channel reserved in the controller. There are many different types of DMX controllable fixtures and they all may vary in the total number of channels required. Choosing a start address should be planned in advance. Channels should never overlap. If they do, this will result in erratic operation of the fixtures whose starting address is set incorrectly. You can however, control multiple fixtures of the same type using the same starting address as long as the intended result is that of unison movement or operation. In other words, the fixtures will be slaved together and all respond exactly the same.

DMX fixtures are designed to receive data through a serial Daisy Chain. A Daisy Chain connection is where the DATA OUT of one fixture connects to the DATA IN of the next fixture. The order in which the fixtures are connected is not important and has no effect on how a controller communicates to each fixture. Use an order that provides for the easiest and most direct cabling. Connect fixtures using shielded two conductor twisted pair cable with three pin XLR male to female connectors. The shield connection is pin 1, while pin 2 is Data Negative (S-) and pin 3 is Data positive (S+). CHAUVET carries 3-pin XLR DMX compliant cables, DMX-10 (33'), DMX-4.5 (15') and DMX-1.5 (5')

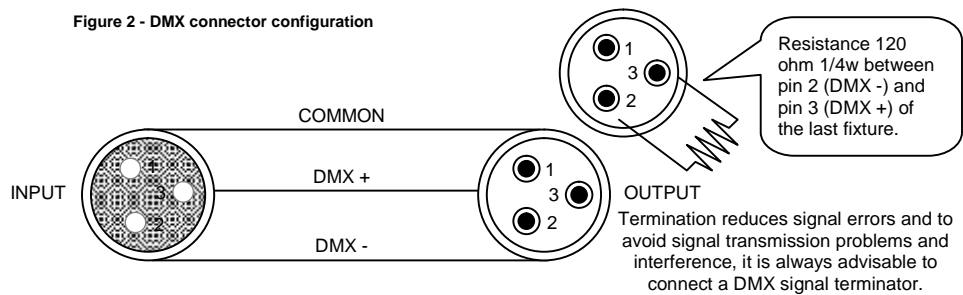

Fixture Linking

Note!

If you use a controller with a 5 pin DMX output connector, you will need to use a 5 pin to 3 pin adapter. CHAUVET Model No: DMX5M. The chart below details a proper cable conversion:

3 PIN TO 5 PIN CONVERSION CHART

Conductor	3 Pin Female (output)	5 Pin Male (Input)
Ground/Shield	Pin 1	Pin 1
Data (-) signal	Pin 2	Pin 2
Data (+) signal	Pin 3	Pin 3
Do not use		Do not use
Do not use		Do not use

DMX Channel Values (16 Bit)

DEFAULT P1-Y	P1-Y	P2-Y	P3-Y	VALUE	FUNCTION
1	1	1	1	000 ⇔ 255	Pan Left > Right (128 = center)
2	2	-> 3 <-	2	000 ⇔ 255	Tilt Up > Down (128 = center)
	3	-> 2 <-		000 ⇔ 255	Pan (Fine)
	4	4		000 ⇔ 255	Tilt (Fine)
	5	5	3	000 ⇔ 000 001 ⇔ 001 002 ⇔ 200 201 ⇔ 204 205 ⇔ 255	Pan/Tilt Speed & Reset Max. Speed (tracking mode) Max. Speed (vector mode) Speed (vector): Max > Min Fixture reset (hold 10 sec) Max. Speed, blackout while in color change (tracking mode) Max. Speed, blackout while in Pan/Tilt movement and or color and gobo changes (tracking mode)
3	6	6	4	000 ⇔ 003 004 ⇔ 063 064 ⇔ 095 096 ⇔ 159 160 ⇔ 191 192 ⇔ 223 224 ⇔ 255	Shutter/Strobe/Dimmer Blackout Dimmer: Closed > Open (0-100%) Variable strobe: Slow > Fast Open Pulse strobe in sequence: Slow > Fast Pulse strobe in sequence: Fast > Slow Open
4	7	7	5	000 ⇔ 015 016 ⇔ 031 032 ⇔ 047 048 ⇔ 063 064 ⇔ 079 080 ⇔ 095 096 ⇔ 111 112 ⇔ 127 128 ⇔ 132 133 ⇔ 144 145 ⇔ 156 157 ⇔ 168 169 ⇔ 180 181 ⇔ 192 193 ⇔ 204 205 ⇔ 216 217 ⇔ 228 229 ⇔ 255	Rotating Gobo Wheel Open Gobo 1 Gobo 2 Gobo 3 Gobo 4 Gobo 5 Gobo 6 Gobo 7 Open Gobo 1 (variable bounce) Gobo 2 (variable bounce) Gobo 3 (variable bounce) Gobo 4 (variable bounce) Gobo 5 (variable bounce) Gobo 6 (variable bounce) Gobo 7 (variable bounce) Open Gobo spin: Slow > Fast
5	8	8	6	000 ⇔ 012 013 ⇔ 024 025 ⇔ 037 038 ⇔ 049 050 ⇔ 062 063 ⇔ 074 075 ⇔ 087 088 ⇔ 099 100 ⇔ 112 113 ⇔ 127 128 ⇔ 190 191 ⇔ 220 221 ⇔ 225 226 ⇔ 255	Color Wheel White (Open) Red Blue Yellow Green Pink UV Light Blue Orange Purple Linear color change with movement of slider (color-splits) Rainbow effect: Fast > Slow (clockwise) Stop Rainbow effect: Fast > Slow (counter-clockwise)
6	9	9	7	000 ⇔ 127 128 ⇔ 189 190 ⇔ 193 194 ⇔ 255	Gobo Rotation & Indexing Gobo Index Clockwise gobo rotation: Fast > Slow No Rotation Counter clockwise gobo rotation: Slow > Fast

Maintenance

To maintain optimum performance and minimize wear fixtures should be cleaned frequently. Usage and environment are contributing factors in determining frequency. As a general rule, fixtures should be cleaned at least twice a month. Dust build up reduces light output performance and can cause overheating. This can lead to reduced lamp life and increased mechanical wear. Be sure to power off fixture before conducting maintenance.

Unplug fixture from power. Use a vacuum or air compressor and a soft brush to remove dust collected on external vents and internal components. Clean all glass when the fixture is cold with a mild solution of glass cleaner or Isopropyl Alcohol and a soft lint free cotton cloth or lens tissue. Apply solution to the cloth or tissue and drag dirt and grime to the outside of the lens. Gently polish optical surfaces until they are free of haze and lint. Do not touch the lamp glass when cleaning fixture. Oil and dirt can cause damage and premature aging of the lamp. In the event that the lamp is touched or becomes dirty, clean the lamps with an alcohol wipe.

The cleaning of internal and external optical lenses and/or mirrors must be carried out periodically to optimize light output. Cleaning frequency depends on the environment in which the fixture operates: damp, smoky or particularly dirty surrounding can cause greater accumulation of dirt on the unit's optics. Clean with soft cloth using normal glass cleaning fluid. - Always dry the parts carefully. - Clean the external optics at least every 20 days. Clean the internal optics at least every 30/60 days.

Returns Procedure

Returned merchandise must be sent prepaid and in the original packing, call tags will not be issued. Package must be clearly labeled with a Return Merchandise Authorization Number (RA #). Products returned without an RA # will be refused. Call CHAUVET and request RA # prior to shipping the fixture. Be prepared to provide the model number, serial number and a brief description of the cause for the return. Be sure to properly pack fixture, any shipping damage resulting from inadequate packaging is the customer's responsibility. CHAUVET reserves the right to use its own discretion to repair or replace product(s). As a suggestion, proper UPS packing or double-boxing is always a safe method to use.

Claims

Damage incurred in shipping is the responsibility of the shipper; therefore the damage must be reported to the carrier upon receipt of merchandise. It is the customer's responsibility to notify and submit claims with the shipper in the event that a fixture is damaged due to shipping. Any other claim for items such as missing component/part, damage not related to shipping, and concealed damage, must be made within seven (7) days of receiving merchandise.

General Troubleshooting

Symptom	Solution(s)	Applies to			
		Lights	Foggers & Snow	Controllers	Dimmers & Chaser
Auto shut off	Check fan thermal switch reset	✓			
Beam is very dim or not bright	Clean optical system or replace lamp Check 220/110v switch for proper setting	✓			
Breaker/Fuse keeps blowing	Check total load placed on device				✓
Chase is too slow	Check users manual for speed adjustment	✓		✓	✓
Device has no power	Check for power on Mains. Check device's fuse. (internal and/or external)	✓		✓	✓
Fixture is not responding	Check DMX Dip switch settings for correct addressing Check DMX cables Check polarity switch settings	✓			
Fixture is on but there is no movement to the audio	Make sure you have the correct audio mode on the control switches. If audio provided via ¼" jack, make sure a live audio signal exists Adjust sound sensitivity knob	✓		✓	✓
Lamps cuts off sporadically	Possible bad lamp or fixture is overheating. Lamp may be at end of its life.	✓			
Light will not come on after power failure	Some discharge lamps require a cooling off period before the electronics in the fixture can kick start it again, wait 5 to 10 minutes before powering up	✓			
Loss of signal	Use only DMX cables Install terminator Note: Keep DMX cables separated from power cables or black lights.	✓	✓	✓	✓
Motor movements are jerky or jumpy	Possible bad motor driver or sensors Check polarity switch on controller	✓		✓	
Moves slow	Check 220/110v switch for proper setting	✓			
No flash	Re-install bulb, may have shifted in shipping	✓			
No light output	Check slip ring & brushes for contact Install bulb Call service technician	✓			
Relay will not work	Check reset switch Check cable connections				✓
Remote does not work	Make sure connector is firmly connected to device	✓	✓		
Stand alone mode	All CHAUVET lighting fixtures featuring stand-alone functions do not require additional settings, simply power the fixture and it will automatically enter into this mode	✓			
Unit wobbles when rotating	Check for damages possibly incurred during shipping	✓			

Technical Specifications

WEIGHT & DIMENSIONS

Length.....	304 (12 in)
Width.....	318 mm (12.5 in)
Height.....	470 mm (18.5 in)
Weight (Q-Spot™).....	14.7 Kgs (32.5 lbs)
Weight (Q-Spot™ 150).....	14.5 Kgs (32 lbs)

POWER

Switch-selectable power settings.....	115V 60 Hz or 230V 50 Hz
AC input.....	3 prongs IEC 60320 C14
European version.....	240V 50 Hz
Current draw (Q-Spot™).....	(peak 324W @ 120V), (inrush 720W @ 120V)
Current draw (Q-Spot™).....	(peak 359W @ 230V), (inrush 741W @ 230V)
Current draw (Q-Spot™ 150).....	(peak 251W @ 120V), (inrush 466W @ 120V)
Current draw (Q-Spot™ 150).....	(peak 289W @ 230V), (inrush 433W @ 230V)

LAMPS

HTI150.....	750 hr, 6500K, 150W
EHJ.....	50 hr, 250W

PHOTO OPTIC

Beam Angle.....	13°
Pan.....	540°
Tilt.....	270°

GOBOS

Outside diameter.....	27mm
Image diameter.....	21.5mm
Thickness.....	3mm

THERMAL

Maximum ambient temperature.....	40° (104° F)
----------------------------------	--------------

FUSE

Main (115V).....	20mm Glass 5A Fast Blow
Internal PCB.....	20mm Glass 4A Fast Blow

CONTROL & PROGRAMMING

Data input.....	locking 3-pin XLR male socket
Data output.....	locking 3-pin XLR female socket
Data pin configuration.....	pin 1 shield, pin 2 (-), pin 3 (+)
Protocols.....	DMX-512 USITT
DMX Channels (16bit).....	9
DMX Channels (8bit).....	6 & 7

ORDERING INFORMATION

Q-Spot™.....	Q-SPOT
Q-Spot™ 150.....	Q-SPOT150