



USER MANUAL



Information in this manual is subject to change without notice and does not represent a commitment on the part of Applied Acoustics Systems DVM Inc. The software described in this manual is furnished under a license agreement. The software may be used only in accordance of the terms of this license agreement. It is against the law to copy this software on any medium except as specifically allowed in the license agreement. No part of this manual may be copied, photocopied, reproduced, translated, distributed or converted to any electronic or machine-readable form in whole or in part without prior written approval of Applied Acoustics Systems DVM Inc.

Copyright © 2009 Applied Acoustics Systems DVM Inc. All rights reserved. Printed in Canada.

Program Copyright © 2009 Applied Acoustics Systems, Inc. All right reserved.

Strum VG is a Trademark of Applied Acoustics Systems DVM Inc. Windows 98, 2000, NT, ME, XP and DirectX are either trademarks or registered trademarks of Microsoft Corporation. Macintosh, Mac OS and Audio Units are registered trademarks of Apple Corporation. VST Instruments and ASIO are trademarks of Steinberg Soft Und Hardware GmbH. RTAS is a registered trademarks of Digidesign. Adobe and Acrobat are trademarks of Adobe Systems incorporated. All other product and company names are either trademarks or registered trademarks of their respective owner. Unauthorized copying, renting or lending of the software is strictly prohibited.

Visit Applied Acoustics Systems DVM Inc. on the World Wide Web at

www.applied-acoustics.com

Contents

1	Introduction	9
1.1	System Requirements	9
1.2	Installation	10
1.3	Authorization and Registration	10
1.3.1	Step 1: Generating the Challenge Key	11
1.3.2	Step 2: Generating the Response Key and Registering your Product	11
1.3.3	Step 3: Completing the Unlock Process	14
1.3.4	Obtaining your Response Key and Registering by Fax or over the Phone:	15
1.4	Getting Started	15
1.4.1	Using <i>Strum Electric</i> in Standalone Mode	15
1.4.2	Exploring the Factory Presets	16
1.4.3	Using MIDI Links	17
1.4.4	Using MIDI Program Changes	17
1.4.5	Using <i>Strum Electric</i> as a Plug-in	17
1.5	Getting Help	17
1.6	Forum and User Library	18
1.7	About this Manual	18
2	An Overview of <i>Strum Electric</i>	19
2.1	Chord Detection and Voicing	19
2.2	Strumming	20
2.3	The Graphical Interface	20
2.4	Signal Flow	20
3	Keyboard Layout	23
3.1	Lead and Chord Keys	23
3.2	Strumming Keys	23
3.2.1	Downstroke and Upstroke	23
3.2.2	Palm Muted Downstroke and Upstroke	24
3.2.3	Muffled Downstroke and Upstroke	24
3.2.4	Mute All	24

3.2.5	Alternate Strum	24
3.2.6	Playing Individual Strings	24
3.3	Pitch Bend Wheel	25
3.4	Aftertouch	26
3.5	Modulation Wheel	26
3.6	Hold Pedal	26
4	Playing Strum	28
4.1	Auto-Strum Mode and Strumming Keys	28
4.2	Playing with Auto-Strum	28
4.2.1	Strum Down	28
4.2.2	Chord Change	29
4.2.3	Chords and Change of Pitch	29
4.2.4	Hammer-On and Pull-Off	30
4.3	Using the Strumming Keys	30
4.3.1	Down- and Upstroke Strum	30
4.3.2	Palm Muted Down- and Upstroke	31
4.3.3	Muffled Down- and Upstroke	31
4.3.4	Arpeggios	31
4.4	Specific Techniques	33
4.4.1	Trills	33
4.4.2	Tremolo Picking	33
4.4.3	Muted Strum	33
4.4.4	Partial Strumming	33
4.4.5	Bass & Chords	34
4.4.6	Stationary Bend	34
4.4.7	Power Chords	35
4.5	Using MIDI Loops	35
4.5.1	Creating MIDI Loops	36
4.5.2	Parameter Override Keyswitches	36
4.6	Chord Voicing	37

5	Presets and MIDI maps	39
5.1	Presets	39
5.1.1	The Preset Library	39
5.1.2	The Program list	40
5.2	Playing and Changing Presets	40
5.3	Editing and Saving Presets	41
5.4	Saving the Program List	42
5.5	Organizing the Preset Library	42
5.5.1	Creating Folders	42
5.5.2	Copying and Moving Presets and folders	43
5.5.3	Renaming Presets and folders	43
5.5.4	Deleting Presets and Folders	43
5.5.5	Documenting Presets	43
5.5.6	Locating a Preset in the Browser	44
5.5.7	Resizing the Browser	44
5.6	MIDI Maps	44
5.7	Exporting and Importing Presets and MIDI maps	44
5.8	Backuping Presets and MIDI Maps	45
5.9	Restoring the Factory Presets and MIDI Links	45
6	Parameters	47
6.1	General Functioning of the Interface	47
6.1.1	Tweaking Knobs	47
6.1.2	Buttons	47
6.1.3	Drop-down Menus and Displays	48
6.1.4	Bypassing a Module	48
6.1.5	Modulation Signals	48
6.2	The Guitar Modules	48
6.2.1	The Strings Module	49
6.2.2	The Pick/Fingers Module	50
6.2.3	The Hammer-On Module	50
6.2.4	The Palm-Mute Module	51

6.2.5	The Pickups Module	51
6.3	The Amplifier Module	52
6.4	The Multi-Effect Module	53
6.4.1	Delay	53
6.4.2	Chorus	53
6.4.3	Flanger	54
6.4.4	Phaser	54
6.4.5	Wah	54
6.4.6	Notch Filter	55
6.4.7	Tremolo	56
6.5	Edit Mode	56
6.5.1	The Strings Module	57
6.5.2	The Pick/Fingers Module	58
6.5.3	The Hammer Module	60
6.5.4	The Mute Module	60
6.5.5	The Palm Module	60
6.5.6	The Pickups Module	61
6.6	Performance Parameters	62
6.6.1	Chord Display	62
6.6.2	Chord	62
6.6.3	Loop	63
6.6.4	Strumming	64
6.6.5	Tuning	65
6.6.6	Pitch Wheel	65
6.6.7	Aftertouch	66
6.6.8	Hold Pedal	66
6.6.9	The Velocity Section	66
6.6.10	Mod Wheel	66

7	Utility Section	67
7.1	The MIDI LED	67
7.2	MIDI channel	67
7.3	Compare	67
7.4	Reverb	67
7.5	Volume	67
7.6	Level Meter	68
8	Toolbar	69
8.1	Program Display	69
8.2	MIDI map	69
8.3	CPU meter	69
8.4	Value Display	69
9	Audio and MIDI Settings	70
9.1	Audio Settings	70
9.1.1	Selecting an Audio Device	70
9.1.2	Audio Control Panel	70
9.2	MIDI Settings	70
9.2.1	Selecting a MIDI Device	70
9.2.2	Creating MIDI Links	71
9.2.3	Editing MIDI Links	71
9.2.4	Deleting MIDI Links	72
9.2.5	Creating a MIDI Map	72
9.2.6	Empty MIDI Map	72
9.2.7	Defining a Default MIDI Map	73
9.2.8	MIDI Program Changes	73
9.3	Latency Settings	73

10 Using <i>Strum Electric</i> as a Plug-In	74
10.1 Window Size	74
10.2 Audio and MIDI Parameters	74
10.3 Automation	74
10.4 Multiple Instances	74
10.5 Saving Projects	74
10.6 MIDI Channel	75
10.7 MIDI program change	75
10.8 Performance	75
11 Quick Reference to Commands and Shortcuts	76
12 Appendix A - List of Chords Detected by <i>Strum</i>	82
13 Appendix B - Parameter Override Keyswitches	89
13.1 Chord Section	89
13.2 Strumming Section	89
13.3 Pitch Wheel Section	90
13.4 Aftertouch Section	90
13.5 Vibrato Section	90
13.6 Velocity Section	91
14 License Agreement	92

1 Introduction

Strum Electric is a synthesizer dedicated to the emulation of electric guitars. The synthesizer is entirely based on the A|A|S physical modeling technology and uses no sampling nor wave tables. Instead it produces sound by solving, on the fly, mathematical equations modeling the different components of a guitar and how they interact. This elaborate synthesis engine responds dynamically to the control signals it receives while you play thereby reproducing the richness and responsiveness of real instruments.

Strum Electric features elaborate modeling of the vibrations of the strings, pick or finger action, the pickups, a two-channel amplifier with speaker cabinet and a spring reverb as well as guitar effects. *Strum Electric* also includes many functionalities which make it easy to reproduce the playing techniques of a guitarist on a keyboard. *Strum Electric* includes a chord detection module and performs automatic voicing of chords. In other words, you play the chords you know on the keyboard and *Strum* will voice them automatically, for different musical styles, as a guitarist would have played them. The picking-hand technique of a guitarist is reproduced by an auto-strum function, special strumming keys or using standard MIDI loops.

Before discussing the synthesizer in more detail, we would like to take this opportunity to thank you for choosing an A|A|S product. We sincerely hope that this product will bring you inspiration, pleasure and fulfill your creative needs.

1.1 System Requirements

The following computer configuration is necessary to run *Strum Electric*:

Mac OS :

- Mac OSX 10.2 (Jaguar) or later.
- G4 733 MHz Processor
- 256 MB RAM
- 1024 x 768 or higher screen resolution
- MIDI Keyboard (recommended)
- Ethernet Port

Windows :

- Windows 98SE/ME/2000/XP
- PIII 800 MHz
- 128 MB RAM
- 1024 x 768 or higher screen resolution
- DirectX or ASIO supported sound card
- MIDI Keyboard (recommended)

Keep in mind that the computational power required by *Strum Electric* depends on the number of voices of polyphony and the sampling rate used. These computer configurations will enable you to play the factory presets with a reasonable number of voices.

1.2 Installation

Mac OS

Insert the *Strum Electric* program disc into your CD-ROM drive. Open the CD icon once it appears on your desktop. Click on the *Strum Electric* Install icon and follow the instructions of the installer.

If you purchased this software online, simply double-click on the installer file that you have downloaded and follow the instructions of the installer.

Windows

Insert the *Strum Electric* program disc into your CD-ROM drive. Launch Explorer to view the content of the CD-ROM and double-click on the installer file to launch the installer.

If you purchased this software online, simply double-click on the installer file that you have downloaded and follow the instructions of the installer.

1.3 Authorization and Registration

Strum Electric uses a proprietary challenge/response copy protection system which requires authorization of the product. A *challenge key* is a long string of capital letters and numbers that is generated uniquely for each machine during the registration process. In other words, for each machine you install this program on, a different challenge key will be generated by the program. The *response key* is another unique string of capital letters and numbers generated from the data encrypted in the challenge key. In order to obtain a response key, you will need to connect to the A|A|S website and provide the following information:

- A valid email address
- Your product serial number (on the back of the sleeve of your CD or in your confirmation email for downloads)
- The challenge key generated by the program

Note that it is possible to use the program during 15 days before completing the authorization process. This period can be convenient if you are installing the program on a computer which is not connected to the internet. After that period, the program will not function unless it is supplied with a response key.

In the following sections we review the different steps required to generate the challenge keys and obtain the response key. The procedure is similar on Windows XP and Mac OS systems.

1.3.1 Step 1: Generating the Challenge Key

After launching the installer for the first time, a pop-up window will appear asking you if you wish to authorize your product now or later. If you are ready to authorize *Strum Electric* now, click on the **Next** button otherwise click on the **Authorize Later** button. If your computer is connected to the internet, we recommend that you authorize your product now.

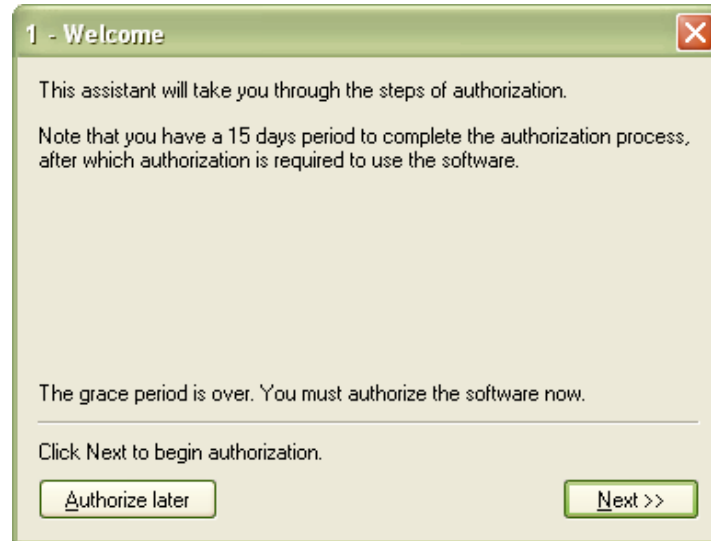

Figure 1: Choosing to authorize *Strum Electric* now or later.

When you click on the **Next** button, a second window appears asking you to enter your serial number. Type your serial number as it appears on the back of the sleeve of the *Strum Electric* CD-ROM. If you purchased *Strum Electric* online, an email with your serial number will have been sent to you at the address which you provided during the purchase process.

After entering your serial number, click on the *Next* button and your challenge key will appear automatically in the next pop-up window.

1.3.2 Step 2: Generating the Response Key and Registering your Product

If your computer is connected to the internet, click on the link to the A|A|S web server appearing in the pop-up window. This will launch your web browser and connect you to the unlock page of the A|A|S web server. Enter your email address, serial number and challenge key in the form as shown below and click on the *Submit* button.

The next form asks you to provide additional information about yourself including your mailing address and phone number. This information will be used to register your product. Note that only a valid email address is required to register your product. We nevertheless recommend this information be provided to ensure our support team is able to contact you to resolve any future

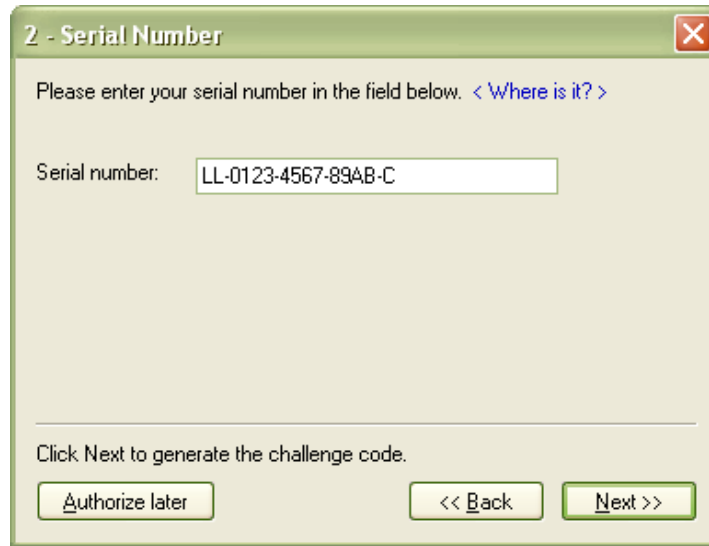

2 - Serial Number

Please enter your serial number in the field below. < [Where is it?](#) >

Serial number:

Click Next to generate the challenge code.

Figure 2: Enter your serial number in the pop-up window.

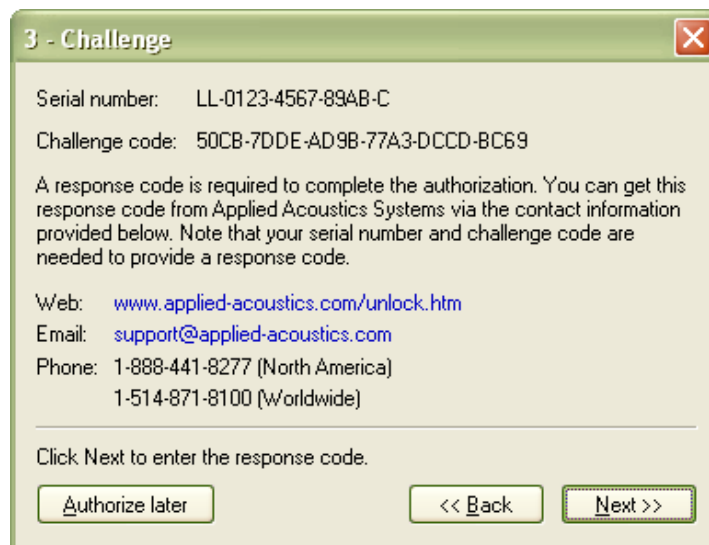

3 - Challenge

Serial number: LL-0123-4567-89AB-C

Challenge code: 50CB-7DDE-AD9B-77A3-DCCD-BC69

A response code is required to complete the authorization. You can get this response code from Applied Acoustics Systems via the contact information provided below. Note that your serial number and challenge code are needed to provide a response code.

Web: www.applied-acoustics.com/unlock.htm

Email: support@applied-acoustics.com

Phone: 1-888-441-8277 (North America)
1-514-871-8100 (Worldwide)

Click Next to enter the response code.

Figure 3: The challenge key appears automatically after entering the serial number.

support issues, and notify you of product updates promptly. This information is kept completely confidential. Registration of your product will entitle you to receive support and download updates when available, as well as take advantage of special upgrade prices offered from time to time to registered A|A|S users. Note that if you already purchased or registered another A|A|S product, the information that you have already supplied under the same email address will appear in the form. Feel free to update this information if it is outdated. Click on the *Submit* button and your response

The screenshot shows the 'COMMUNITY' section of the Applied Acoustics Systems website. At the top, there is a navigation menu with links for PRODUCTS, SUPPORT, BUY, NEWS / PRESS, ABOUT US, COMMUNITY, and UNLOCK. Below the menu is a banner with the company name 'APPLIED ACOUSTICS SYSTEMS'. The main heading reads 'Please enter your email address for registration of your product.' Below this, there are three input fields: 'Email Address' (empty), 'Serial Number' (containing 'LL-0123-4567-89AB-C'), and 'Challenge Key Question' (containing '50CB-7DDE-AD9B-77A3-DCCD-BC69'). A 'Submit' button is located below the fields.

Figure 4: Enter your registration information on the A|A|S webserver.

key will appear on-screen.

The screenshot shows the 'COMMUNITY' section of the Applied Acoustics Systems website after registration. The navigation menu and banner are the same as in Figure 4. The main heading reads 'Thank you for your registration.' Below this, the 'Challenge' key is displayed as '689E-D9FF-D9BF-33B2-A3B3-0335' and the 'Response' key is displayed as '6D88-771C-A809-E274-51BE'. A note states 'A copy of this information will be sent to you by email.' The 'COMMUNITY' section title is visible at the bottom.

Figure 5: Generation of the response key on the A|A|S server.

If your computer is not connected to the internet, take note of your serial number and *challenge key* and proceed to an internet connected computer. Launch your browser and go to the unlock page of the A|A|S website at:

<http://www.applied-acoustics.com/unlock.htm>

Enter your email address, serial number, and *challenge key*, and click next. You will then receive your response code on-screen as described above.

1.3.3 Step 3: Completing the Unlock Process

The *response key* corresponding to your serial number and *challenge key* will be printed in your browser window. In order to complete the unlock process, copy the *response key* and paste it into the corresponding field of the installer window of *Strum Electric*. If you obtained your *response key* from another computer, type the *response key* by hand in the installer window.

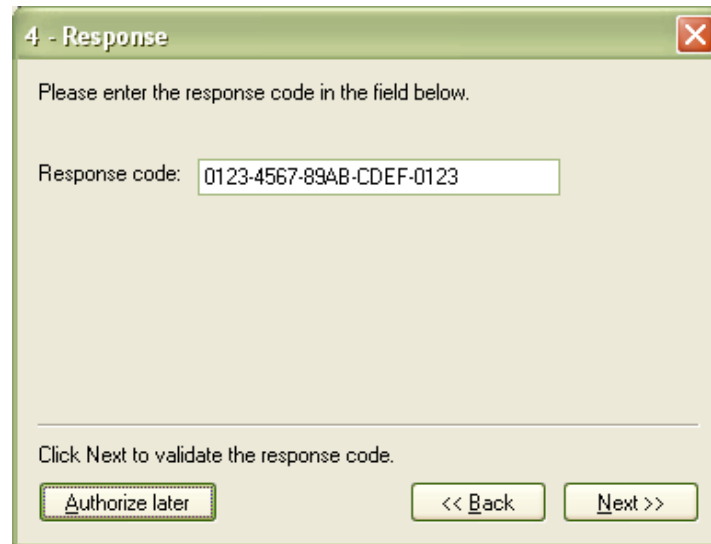

Figure 6: Final step of the unlock process. Enter your *response key* in the window.

Click on the *Next* button and a pop-up window will appear informing you that the authorization process has been successful. Click on the **Finish** button to complete the process and launch *Strum Electric*.

You will normally only need to go this process once for a given computer except for some special cases. On Windows computers you will need to unlock again if:

- You change your computer
- You reformat or upgrade your hard drive
- You change or upgrade your operating system

On Mac OS computers, this will only be necessary if:

- You change your computer
- You change the motherboard of the computer

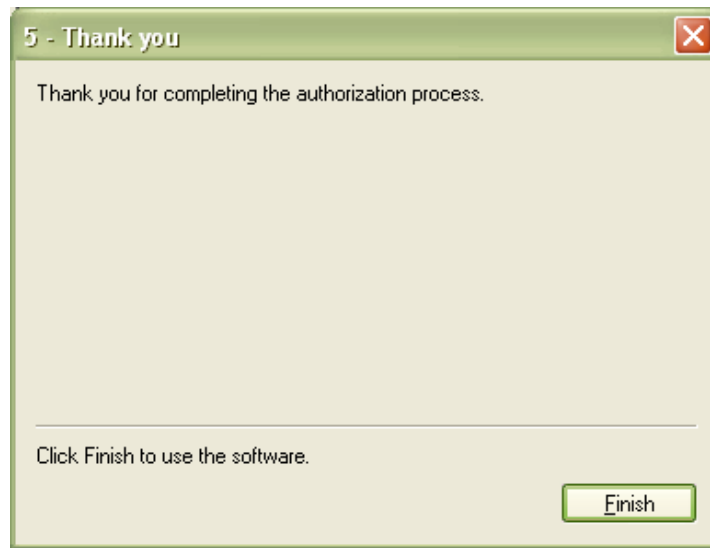

Figure 7: Authorization has been successful.

1.3.4 Obtaining your Response Key and Registering by Fax or over the Phone:

Should you not have access to the internet, A|A|S support representatives are available to assist you in the unlock and registration process Monday to Friday, 9am to 6pm EST. You may contact us by phone at:

- North America Toll-free number: 1-888-441-8277
- Outside North America: 1-514-871-8100
- Fax Number: 1-514-845-1875
- Email: support@applied-acoustics.com

1.4 Getting Started

1.4.1 Using *Strum Electric* in Standalone Mode

The *Strum Electric* comes with a wide range of factory presets right out of the box which amounts to a huge range of sounds before you have even turned a single knob. As you would expect, the best way of coming to grips with the possibilities *Strum Electric* offers is simply to go through the presets one at a time. We recommend that you first start using *Strum Electric* in standalone mode.

- **Windows** - Double-click on the *Strum Electric* icon located on your desktop or select *Strum Electric* from the **Start > All Programs >** menu.

- **Mac OS** - Double-click on the *Strum Electric* icon located in the Applications folder.

Before you start exploring the factory presets, take a moment to set up your audio and MIDI configuration as explained below.

Audio Configuration

Audio configuration tools are available from the **Audio** menu. The **Audio Settings** function allows you to select an audio output device from a list, organized by driver type, of those available on your computer. On Windows, if you have ASIO drivers available, these should be selected for optimum performance. Multi-channel interfaces will have their outputs listed as stereo pairs.

- Select your sound card port from the list in the **Audio Configuration** dialog from the **Audio > Audio Settings ...** menu.

For more detailed information on audio configuration, sampling rate selection and latency adjustments, please refer to section 9.3.

MIDI Configuration

MIDI configuration tools are available from the **MIDI** menu.

- Select your MIDI input device from the list in the **MIDI Configuration** window available from the **MIDI > MIDI Settings ...** menu.

For more detailed information on Audio and MIDI configuration, MIDI links and MIDI maps, please refer to Chapter 9.

1.4.2 Exploring the Factory Presets

Factory presets can easily be accessed using the ‘+’ and ‘-’ buttons in the lower left corner of the toolbar. These buttons are used to navigate through a list of 128 numbered presets called programs. The content of this program list can be viewed by clicking on the ▼ button of the toolbar. The number of the current program used and the name of the associated preset appear on the right of this button. Programs can also be changed by using the ‘+’ and ‘-’ keys from the computer keyboard or by selecting programs directly from the list displayed after clicking on the ▼ button.

Presets can also be accessed using the browser appearing on the left of *Strum Electric*. This browser is similar to the browser your operating system generates to display the contents of your hard disk, or your email program uses to organize your mail and address book. When launching the

application for the first time, this “tree view” will include a destination folder for imported presets as well as a **Presets** folder. To open a folder, click on the “+” symbol on Windows or ► symbol on Mac OS which will reveal the folder content.

The preset library is different from the program list and can be viewed as a repository containing all the presets available to the application. Presets are loaded into the synthesis engine by copying them from the library into the program list. To load a preset, double-click on a preset icon (blue knob) or preset name. This will insert the preset into the program list at the position of the current program. You can also use the arrow keys on the computer keyboard in order to navigate in the preset list and then the Enter key to load a preset. For additional information on presets and programs, please refer to Chapter 5 of this manual.

1.4.3 Using MIDI Links

Every parameter on the *Strum Electric* interface can be linked to an external MIDI controller. To assign a MIDI Link, right-click (control-click on Mac) on a control (knob, button or slider) and a contextual menu will appear. Select **Learn MIDI Link** and move a knob or slider on your MIDI controller to activate the link. To deactivate the link, right-click (control-click on Mac) on the control and choose the **Forget MIDI Link** command. Refer to section 9.2 for more details on MIDI links.

1.4.4 Using MIDI Program Changes

The synthesizer responds to MIDI program changes. When a program change is received, the current program is changed to the program having the same number as that of the program change message received by the application.

1.4.5 Using *Strum Electric* as a Plug-in

Strum Electric integrates seamlessly into the industry’s most popular multi-track recording and sequencing environments as a virtual instrument plug-in. *Strum Electric* works as any other plug-in in these environments so we recommend that you refer to your sequencer documentation in case you have problems running *Strum Electric* as a plug-in.

1.5 Getting Help

A|A|S technical support representatives are on hand from Monday to Friday, 9am to 6pm EST. Whether you have a question on *Strum Electric*, or need a hand getting it up and running as a plug-in in your favorite sequencer, we are here to help. Contact us by phone, fax, or email at:

- North America Toll Free: 1-888-441-8277

- Worldwide: 1-514-871-8100
- Fax: 1-514-845-1875
- Email: support@applied-acoustics.com

Our online support pages contain downloads of the most recent product updates, and answers to frequently asked questions on all A|A|S products. The support pages are located at:

www.applied-acoustics.com/support.php

1.6 Forum and User Library

The A|A|S community site contains the *Strum Electric* user forum, a place to meet other users and get answers to your questions. The community site also contains an exchange area where you will find presets for your A|A|S products created by other users and where you can make your own creations available to other users.

<http://community.applied-acoustics.com/php/community/>

<http://community.applied-acoustics.com/php/forum/>

1.7 About this Manual

In the next chapter, the general functioning of *Strum Electric* is presented. Chapter 3 describes the special keyboard layout used to play *Strum Electric*. Playing techniques are then presented in chapter 4. Chapter 5 explains how to use the application browser and how presets and MIDI maps are managed. In Chapter 6, the different modules and controls are reviewed in detail. In Chapter 7 the utility, or top part, of the interface is reviewed. Chapter 8 describes the different functionalities available from the toolbar while Chapter 9 explains the different functionalities related to Audio and MIDI and their settings. General issues involved in the use of *Strum Electric* as a plug-in in different host sequencers is covered in Chapter 10. Finally a list of available commands and shortcuts is given in Chapter 11.

Throughout this manual, the following conventions are used:

- Bold characters are used to name modules, commands and menu names.
- Italic characters are used to name controls on the interface.
- Windows and Mac OS keyboard shortcuts are written as Windows shortcut/Mac OS shortcut.

2 An Overview of *Strum Electric*

Strum Electric is a synthesizer which was designed with the goal of enabling keyboard players to easily create realistic guitar tracks. This is a task which is usually difficult to achieve due to the very different nature of these two types of instruments. *Strum* was therefore designed to reproduce not only the sounding mechanism of a guitar but also the main elements of the playing technique of a guitar player.

Very generally playing on a guitar can be described in terms of fretting hand (usually left hand) and picking hand (usually right hand) techniques. The fretting hand is used to fix the chords or notes played on the different strings of the guitar while the picking hand is used to set the different strings into vibration and therefore play melodies or strumming patterns. In *Strum*, these functions have been integrated into a chord detection, voicing, and strumming module.

2.1 Chord Detection and Voicing

Chords played on a keyboard and a guitar share the same name but are played or voiced differently. Because of the tuning of the strings on a guitar, the notes of the chord are not usually played in the same order as on a keyboard and the range of the notes is usually different, notes may also be repeated. Furthermore, the same chords can be played in different positions on the guitar depending on the playing or musical style. This specific way of playing chords on a guitar is very characteristic of the tone and sound of the instrument. It is therefore very important, in order to obtain a realistic guitar sound, to play chords as a guitar player would rather than how they are played on the keyboard.

The voicing of chords for the guitar is performed in two steps by *Strum*. A chord played on the keyboard is first interpreted by the chord detection module in order to determine which chord was played on the keyboard. *Strum* then finds a guitar voicing corresponding to this chord. In other words, *Strum* finds how a guitar player would have played this particular chord.

When chords are played on the keyboard, the order of the notes above the root is not taken into account by the chord detection engine. This implies that you can play the chords as you know them on the keyboard without having to know or learn special voicings used by guitar players. For example, you could play chords in close position with the left or right hand, you could also play the root with the left hand and the rest of the chord with the right hand or play the chords with the notes spread across both hands. *Strum* will take care of finding the right voicing and playing position on the guitar depending on the settings of the chord type and playing position controls as described in section 4.6

The name of the chord detected as well as the specific voicing chosen by *Strum* is displayed in the fretboard located in the lower portion of the graphical interface. Note that the voicing chosen by *Strum* varies depending on the chord type chosen by the user as is described in Section 4.6. *Strum* will try to detect a chord as soon as three or more keys are depressed on the keyboard. Otherwise *Strum* will assume that a melody or interval is played. Please refer to section 12 for a list of the chords detected by *Strum*.

2.2 Strumming

On a guitar, notes and chords are triggered by the action of the picking hand (usually right hand). The resulting sound is very typical of a guitar as the guitarist triggers the strings sequentially, more or less rapidly, with an up and down motion of the hand. Strings can also be played individually, in different order, to create arpeggio patterns. Different sonorities can be obtained by damping or muting the strings either by applying the picking hand on the strings near the bridge (palm muting) or releasing the pressure on the notes played with the fretting hand (scratching) while strumming. Using these different types of hand motions and techniques, the guitarist can create complex melodic and rhythmic patterns. In *Strum*, these different effects can be achieved through a strumming module which is controlled by special strumming keys or MIDI loops as will be explained in more details in Chapter 3, 4 and 6.

2.3 The Graphical Interface

The graphical interface of the instrument is divided in three sections. From top to bottom on the interface one first finds the output effect section which is used to shape the final sound of the instrument. This effect section includes an equalizer a multi-effect module with sync capabilities and a reverb.

The middle guitar-shaped section of the interface is where all the parameters controlling the synthesis engine are located. The different control parameters refer to the strings, the pick and its interaction with the strings, the action of fingers on the fretboard and the pick-ups of the guitar. This section has seven different views. The main and simplest one (*All*) is used to display parameters acting on the six strings of the guitar while the other six views reveal parameters for the individual strings.

The bottom part of the interface is centered around a fretboard where the chords detected and the specific voicings chosen by *Strum* are displayed. This section of the interface also includes parameters determining how the voicing and strumming is performed by *Strum*, a MIDI loop player, tuning parameters and controls determining how signals from some standard MIDI controllers are interpreted by *Strum*.

2.4 Signal Flow

The general signal flow of *Strum* is presented in Figure 9 and illustrates schematically how the different modules in *Strum* interact. From left to right, the synthesizer first includes a chord detection module which parses the MIDI signal it receives and determines the chords played on the keyboard. This information is then sent to the voicing engine which, taking into account how a guitarist would actually play the different chords, determines which notes are played on the different strings of the guitar. The corresponding information, for each of the six strings of the instrument, is then sent to a triggering or strumming module which generates an excitation signal for each of the individual string. This is the signal received by the synthesis or string module which then simulates



Figure 8: Graphical user interface of *Strum Electric GS-1*.

the vibration signal of the individual strings of the guitar. The motion of the strings is the input signal of the pickup module which reproduces the effect of single coil or humbucker-fitted pickups. The output signal from this module constitutes the output signal from the guitar itself. This is the signal which is sent to the amplifier module which simulates a two-channel amplifier with speaker cabinet. Finally an effect rack has been included in order to allow further processing and expand the tonal possibilities of the instrument.

It is important to note how the MIDI signal received by the synthesizer is parsed. Signal received from the MIDI input or MIDI player module, is interpreted in terms of the fretting hand (usually left hand) and picking hand (usually right hand) of a guitar player. MIDI notes with number ranging between 40 (E1) and 70 (Bb4) are associated with the fretting hand and their corresponding signal is sent to the chord detector. Notes with number ranging between 71 (B4) and 84 (C6) are special strumming keys, used to trigger different picking hand techniques, and are therefore used to control the strumming engine. The use of these strumming keys is explained in more details in section 3.

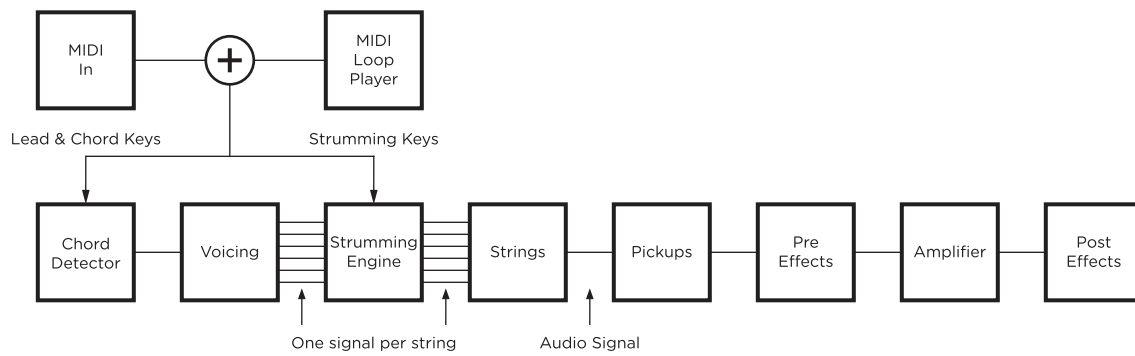

Figure 9: General architecture of *Strum*.

3 Keyboard Layout

Strum reacts to MIDI signal differently than a traditional synthesizer. It uses a special keyboard layout and associates signals from standard MIDI controllers with specific effects or techniques on the guitar. In this chapter, we will describe how the keyboard is used to play *Strum*.

The MIDI signal received by *Strum* is interpreted in terms of the fretting hand (usually left hand) and picking hand (usually right hand) of a guitar player. The range of the MIDI keyboard has therefore been divided into two sections, the *Lead & Chord keys* section and the *Strumming Keys* section as illustrated in Figure 10.

3.1 Lead and Chord Keys

This section is associated with the fretting hand of the guitarist and includes notes ranging from MIDI note numbers 40 (E1) to 70 (Bb4). This section of the keyboard is where melodies and chords are played and it is the MIDI signal from this section which is sent to the chord detection and voicing modules. *Strum* will try to detect a chord and find a corresponding voicing as soon as three keys or more are depressed on the keyboard, otherwise it will play the notes as a melody or an interval.

3.2 Strumming Keys

Notes with MIDI number ranging between 71 (B4) and 84 (C6) are interpreted as special strumming keys and are used to trigger different picking hand techniques as shown in Figure 10. Depending on the strumming keys used one can trigger downstrokes, upstrokes as well as palm muted or muffled downstrokes and upstrokes. Strings can also be triggered individually to play arpeggio patterns. The effect of the different strumming keys is now reviewed.

3.2.1 Downstroke and Upstroke

A downstroke is achieved by dragging a pick (or the fingers) across the strings of the guitar in a downward motion. Notes are therefore played from lowest to highest. An upstroke is obtained in the same manner but dragging the pick or fingers upwards from the highest to the lowest string. A downstroke is triggered by depressing MIDI note 72(C5) while an upstroke is triggered by depressing MIDI note 74 (D5). These strokes represent the simplest way to play chords on a guitar and can be played alternately. Note that when strings are not used in a specific voicing (strings marked with an X in the chord display of the graphical interface), they are not played when using a downstroke or an upstroke.

3.2.2 Palm Muted Downstroke and Upstroke

Palm muting is a technique which consists in partially muting the strings with the help of the picking hand by letting it lightly touch the strings near the bridge. The pick (or fingers) is then dragged across the strings in a downward or upward motion. In *Strum*, the palm muted downstroke and upstroke are obtained by depressing MIDI note number 73 (C#5) and 75 (D#5) respectively.

3.2.3 Muffled Downstroke and Upstroke

A muffled stroke (or scratch) is obtained by laying the fretting hand on the strings without depressing them and then striking the strings with the picking hand. This produces a percussive sound and the guitar player can control the effect by applying more or less pressure on the strings. In *Strum*, the muffled downstroke and upstroke are obtained by depressing MIDI note number 78 (F#5) and 80 (G#5) respectively.

3.2.4 Mute All

A muted strum is a stroke which is immediately muted by applying the full hand on all the strings in order to completely stop the sound. In *Strum*, this effect is reproduced by depressing the MIDI note number 82 (Bb5).

3.2.5 Alternate Strum

It is common for guitar players to vary the number of strings which are strummed when playing rhythmic patterns on a chord. In *Strum* it is possible to define a main and an alternate strum using the *strumming range* control as explained in section 6.6.4. The MIDI note 71(B4) is used to switch between these two types of strum. When this key is depressed while another strumming key is used, the alternate strum is played. The main strum range is used when it is released. This rule applies to the standard up and down strums but also to the palm muted and muffled strokes. The alternate strum can also be triggered with the hold pedal when the *Alt. Strum* button is switched on as explained in section 6.6.8

3.2.6 Playing Individual Strings

The strings of the guitar can be played individually enabling one to arpeggiate or create finger picking patterns. Individual strings are triggered by depressing MIDI notes 76(E5), 77(F5), 79(G5), 81(A5), 83(B5) or 84(C6). These special strumming keys are labeled bass, alternate bass, arp 4, arp 3, arp 2 and arp 1 respectively. Notes in the chords are triggered by these MIDI notes from lowest to highest using the following rules:

- **MIDI note 76(E5): Bass.** always the lowest note in the chord played by *Strum*.

- **MIDI note 77(F5): Alternate bass.** When the chord played by *Strum* is not inverted and the chord includes a fifth (natural, lowered or raised) then the alternate bass is the fifth. If the bass is played on the lowest string (sixth string), then the alternate bass will be played on the fifth string if possible except in the case of the open G chord where it is played on the fourth. If the bass is not played on the lowest string (played on the fifth or fourth string), the alternate bass will then be played on the fifth or sixth string. Finally, if the chord is inverted, or if it does not include a fifth, the alternate bass trigger will play the same note as the bass.
- **MIDI note 79(G5), 81(A5), 83(B5) or 84(C6): Arp key 4, 3, 2 and 1.** The remaining notes in the chord are played from lowest to highest note on arp keys 4 to 1 respectively. If there are fewer than four notes remaining to be played in the chord, the highest one is repeated on the remaining arp keys. Finally, if the alternate bass is the fifth and if it can only be played on the string on which it is played in the chord, it is triggered by the alternate bass arp key and it is not repeated on another arp key.

These rules imply that the arp keys 6 to 1 do not necessarily correspond to string 6 to 1 (lowest to highest). In fact they only do when the six strings are used in a chord and when the bass is played on string 6. This is true for example with bar chords played using the six strings. To illustrate these rules let's consider different chords played in movable position. A G major chord with bass played on G2 on the keyboard will be voiced by *Strum* with the bass on the sixth string. The arp key will then follow the order of the guitar strings. Playing a C major chord with the bass played on C3 on the keyboard results in a chord voiced by *Strum* with the bass on string 5 and the alternate bass on the sixth string. The bass and alternate bass arp keys will therefore trigger the fifth and sixth string respectively. The remaining arp 4,3,2,1 keys will trigger the fourth, third, second and first strings respectively. Finally, playing a G Major chord one octave higher than previously (bass on G3 on the keyboard) results in a chord played by *Strum* on the four highest strings of the guitar (strings 4,3,2,1). In this case, the bass arp key will trigger the fourth string, the alternate bass will be played on the fifth string and the remaining three notes of the chord (strings 3, 2 and 1) will be triggered by arp keys 4, 3 and 2 respectively. The first string will also be triggered by arp key 1.

3.3 Pitch Bend Wheel

The pitch bend wheel produces a slide or a bend depending on the settings of the *Pitch Wheel* section of the interface. The *Range* parameter is used to determine the number of semi-tones in the slide or bend.

In slide mode, all the strings played in a chord are slid. It is not possible to play lower than the lowest note of a string when sliding downward. In this case, the slide range will be limited.

In bend mode, only one string is bended at a time. If a chord was just strummed, the highest note of the chord is bended. If an individual note was just played, this note is bended.

3.4 Aftertouch

In *Strum*, bending can be controlled using monophonic aftertouch (also known as channel pressure on certain controllers). The pitch of the note can be increased in this way by up to one tone depending on the settings of the *Bend* control of the *Aftertouch* section of the interface. If a chord was just strummed, the highest note of the chord is bended. If an individual note was just played, this note is bended.

3.5 Modulation Wheel

The modulation wheel is used to control vibrato.

3.6 Hold Pedal

The hold pedal (MIDI CC 64) can be used either as a hold pedal or to activate alternate strumming depending on the settings of the *Hold Pedal* section of the interface.

In *Hold Chord* mode, the pedal will hold the chord played by *Strum* as long as the pedal is not released. If a new chord is detected while the pedal is still depressed, the new chord will be played. The pedal therefore enables one to do instantaneous chord changes.

In *Alt. Strum* mode, the pedal acts exactly as the first strumming key, MIDI note 71(B4), described above. As long as the pedal is depressed, all the strumming keys will use the range of the alternate strum when triggering strings. When the pedal is released the main strum range is used.

Strum Electric GS-1

QUICK REFERENCE SHEET

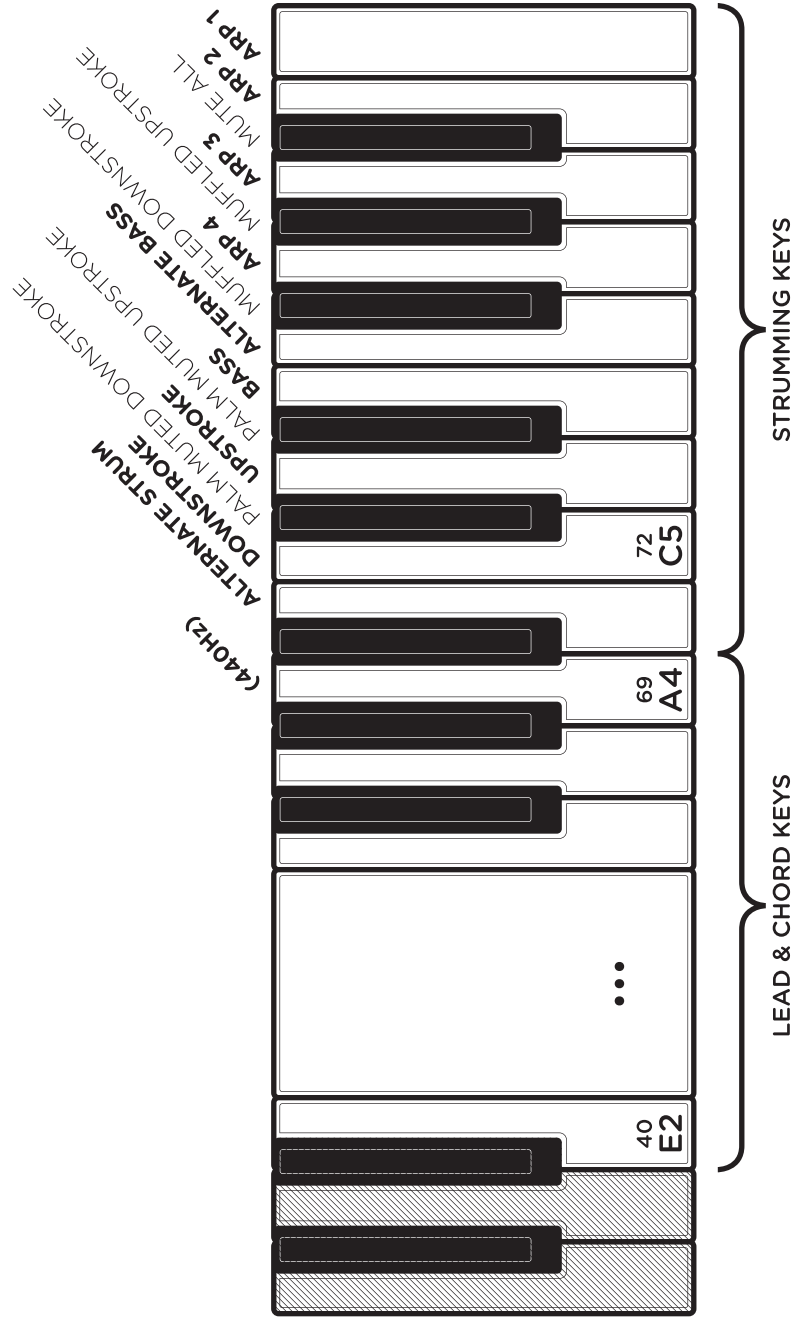

Figure 10: Sections of the MIDI keyboard as used by *Strum*.

4 Playing Strum

Strum can be played in different ways, directly from a MIDI keyboard or using MIDI loops. In this section we describe these different approaches and how to reproduce specific techniques used by guitar players. We conclude this section by describing the different voicing options used by *Strum*.

4.1 Auto-Strum Mode and Strumming Keys

Notes and chords are triggered as they are played on the keyboard when the *Auto-Strum* mode is selected. This mode is switched *on* or *off* by clicking on the *Auto* button in the *Strumming* section of the interface. In *Auto-Strum* mode, the notes forming the chord are played using a downstroke or in other words, notes are played from lowest to highest.

When the *Auto-Strum* mode is switched *off*, notes and chords are processed by the chord detection and voicing modules but the strings are not triggered. In order to play them, one must use the different strumming keys as described in section 3.2. As soon as a strumming key is depressed, the strings are triggered. Using strumming keys involves thinking like a guitarist and use the left hand to play chords or melodies while using the right hand to control the triggering of strings. Note that strumming keys are always active whether the *Auto-Strum* mode is switched *on* or *off*. In the case where the *Auto-Strum* mode is switched *on* and chords are played simultaneously with strumming keys, the strumming keys override the normal behavior of the *Auto-Strum* mode.

4.2 Playing with Auto-Strum

For the first examples, it is necessary to put *Strum* in *Auto-Strum* mode by clicking on the *Auto* button located in the *Strumming* section of the the lower part of the interface.

4.2.1 Strum Down

Play a chord in the *chord & lead* section of the keyboard as shown in Figure 11. The chord is detected by *Strum* and voiced on the guitar fretboard. This triggers a downstroke from the strumming module and consequently the strings are played from the lowest to the highest. In order to trigger a new downstroke without muting the strings, just release one note from the chord and play it again as shown in Figure 12.



Figure 11: A simple strumming sequence.

4.2.2 Chord Change



Figure 12: Re-triggering a downstroke.

Once a chord has been played, the chord detection, voicing and strumming modules are only triggered when a new note is played; releasing notes from a chord has no effect. Consequently, *Strum* holds the current chord as long as all its notes are not released. This can be used to make rapid chord changes. For example, it is possible to switch from a C chord to a G chord without muting the strings by playing C-E-G and then by replacing C and E by B and D without releasing the G as shown in Figure 13. The same effect can be obtained with chords which do not share common notes by using the hold pedal in *Hold Chord* mode.

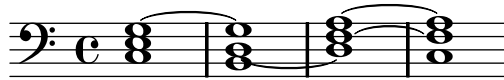

Figure 13: Smooth chord transition.

On the other hand, if one wishes to remove a note from a chord, for example to switch from a C7 chord (C-E-G-B \flat) to a C chord (C-E-G), it is not sufficient to release the B \flat key. It is necessary, in order to trigger again the chord detection module, not only to release the B \flat from the chord but also to release another note from the chord, for example the G, and replay it when one wants to strum the new chord.

4.2.3 Chords and Change of Pitch

Playing chords on higher or lower notes on the keyboard has a similar effect on *Strum*'s fretboard. With so-called *Lowest* chord types (Open-Lowest, Movable-Lowest and Drop-Lowest) *Strum* will make sure that the lowest note played on the keyboard is also the lowest one played in the guitar chord. These chord types are useful when it is necessary that a succession of chords follows a certain bass motion.

With the so-called *Root* chords (Open-Root, Movable-Root), chords detected as inverted are played on the root note located below the lowest note played on the keyboard (if possible).

4.2.4 Hammer-On and Pull-Off

Hammer-on and pull-off are playing techniques used by guitar players to play legato or grace notes. The hammer-on effect is obtained by first picking a note and then hammering down another finger onto the same string at a higher fret. The pull-off effect is almost the opposite of the hammer on. It is obtained by first picking a note and then sharply pulling-off the finger from the fretboard in order to hear a second fretted note on the same string. The sounds produced using these techniques are softer and less percussive than the ones produced by picking the notes.

With *Strum*, hammer-ons and pull-offs are automatically triggered by playing legato notes spaced by one or two semi-tones. They are triggered only when melodies are played and never when chords are detected.

4.3 Using the Strumming Keys

We now look at ways to create more elaborate effects. For these examples, it is assumed that the *Auto-Strum* mode is switch *off* as we will now be using the strumming keys. This way of playing *Strum* involves to think more in terms of a guitar player. Indeed, as the chord recognition and voicing module require some time to voice the chords, it is necessary to play the chords slightly before triggering the strumming action with the strumming keys. This is just like a guitar player who needs to position the fretting hand on the fretboard before strumming with the picking hand.

4.3.1 Down- and Upstroke Strum

Once a chord is played on the keyboard, the *downstroke* strumming key (C5) is used to trigger a strum from the lowest to highest string. The *upstroke* strumming key (D5) is used to trigger strums from the highest to the lowest string of the guitar. The number of strings which are strummed is determined by the main strum parameter which appears below the fretboard in the lower part of the interface. The strumming speed can be controlled using the *Speed* parameter or the *Velocity* control which is used to adjust the amount of modulation from the MIDI velocity signal received from the keyboard.

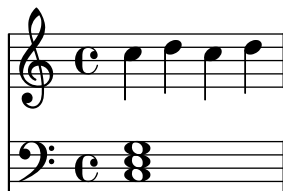

Figure 14: Downstroke and upstroke with the strumming keys.

In the case where only one or two notes are played on the keyboard, the notes can be triggered from both the downstroke or upstroke strumming key and the *Range* parameter is ignored. If no note is played on the keyboard, the downstroke and upstroke keys trigger a strum over the range defined by the *Range* parameter but the strings are muted. The effect is the same as using the muffled down- and upstroke keys which are described below.

4.3.2 Palm Muted Down- and Upstroke

Palm muting is a technique used by guitar players to muffle the strings slightly while simultaneously playing the strings with the picking hand. It is obtained by placing the side of the picking hand on the strings just before the bridge. Palm muted down- and upstroke are triggered by using C \sharp and D \flat 5 respectively.



Figure 15: Palm muting with the arp keys.

4.3.3 Muffled Down- and Upstroke

On a guitar, fretted notes can be muted by decreasing the pressure applied by the fretting fingers on the string. The guitarist can control the effect by applying more or less pressure on the strings and obtain a percussive effect by striking the strings with the picking hand. This effect is also known as scratching.

Now, play a chord on the keyboard and use the muffled Down- and Upstroke keys (F \sharp and G \sharp 5). The strings are played as if the guitarist was muting them with the fretting hand. The effect is the same as using the down- and upstroke keys without playing a chord on the keyboard, but these strumming keys allow one to obtain the effect without releasing the chord.

4.3.4 Arpeggios

A chord can be arpeggiated using the bass, alternate bass, arp 4, arp 3, arp 2 and arp 1 strumming keys (E5, F5, G5, A5, B5 and C6). The effect of these keys depends on the chord played by *Strum* as explained in section 3.2.6. As many chords include only four strings (a bass and three high notes) it is common for the arp 2 and arp 1 keys to play the same note. Furthermore, depending on the position of the chord on the fretboard, the alternate bass key (arp 5 key), can play a lower,



Figure 16: Scratching with the arp keys.

higher or the same note as the bass key (arp 6 key). The most useful arp keys are therefore usually the bass, arp 4, arp 3 and arp 2 keys (E5, G5, A5 and B5). A good position to play arpeggios is to use the thumb to play the bass, the index to play the arp 4 key, the middle finger for the arp 3 key, the ring finger for the arp 2 key and finally the little finger for the arp 1 key. This position is similar to that of a guitar player.

Here is a simple example of an arpeggio. Play a C chord (C-E-G) with the left hand, and then use the right hand to trigger the Bass (E5), arp 4 (G5), arp 3 (A5) and arp 2 (B5) keys.

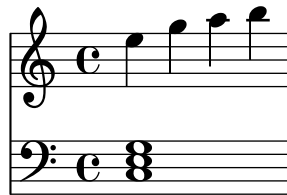

Figure 17: A simple arpeggio.

When playing arpeggios, it might be interesting to use *Movable-Lowest* chord types in order to obtain a motion of the bass. To try this, set the *Type* from the *Chord* section to *Movable-Lowest* and play the arpeggio from the preceding example using the following chord progression: C (C-E-G), CMaj7/B (B-C-E-G), C7/Bb (Bb-C-E-G) and Am7 (A-C-E-G).



Figure 18: Bass motion and arpeggios.

4.4 Specific Techniques

4.4.1 Trills

This technique consists in switching rapidly between two notes by using hammer-ons and pull-offs. With *Strum*, a trill is played by holding the first note and depressing and releasing the second note. The interval between the notes must be one or two semi-tones.

4.4.2 Tremolo Picking

This technique consists in repeating the same note very rapidly. With *Strum*, it is possible to take advantage of the fact that all arp keys play the same string when only one note is played on the keyboard. It is therefore possible to trigger again the same note by switching rapidly between two or more arp keys with the right hand.

4.4.3 Muted Strum

A muted strum is a stroke which is muted immediately after having been played by applying the full hand on the strings. It is less dry than a scratch (muffled stroke) and brighter than a palm muted stroke. One way to recreate this effect is to strum a chord using the down- and upstroke keys (C5 or D5) and playing the mute all key (B♭5) very rapidly.

4.4.4 Partial Strumming

A guitarist does not always strum all the strings in a chord. This is why *Strum* offers the possibility to adjust the strumming range. But guitarists also often vary the number of strings played between strumming strokes. *Strum* therefore allows one to define a main and an alternate strumming range. The main range is used when using the standard strumming keys while the alternate strum is activated by using the same keys but by also holding the alternate strum key (B4). The alternate strum can also be activated by using the hold pedal when it is set to *Alt. Strum* mode which can be more convenient.



Figure 19: Changing the strumming range using the *Alt. Strum* key.

Another technique which can be used to obtain partial strums consists in releasing strumming keys before the strum is completed. In this way, the strings still not strummed, are not played. In other words, partial strumming is achieved by playing staccato on the strumming keys while full strums are obtained by playing them normally. This technique is easier to perform when the strumming speed is relatively slow.

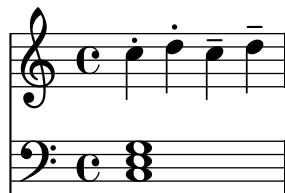

Figure 20: Reducing the strumming range by playing staccato.

4.4.5 Bass & Chords

In certain musical styles, such as country and bluegrass music, one often finds rhythm-guitar patterns obtained by switching between the root or fifth played on the bass string and a strum on the remaining strings. To obtain this effect, it is therefore important that the lowest string is not included in the stroked part of the pattern. In order to reproduce this effect with *Strum*, one must first use the bass or alternate bass key (E5 or F5) and hold it while playing one of the stroke triggers. Indeed, when *Strum* detects that a stroke key is played while the bass or alternate bass key is depressed, it removes this string from the strum.

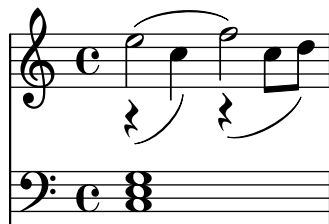

Figure 21: Bass and Chord.

4.4.6 Stationary Bend

In this technique, the guitarists plays two notes simultaneously and bends one of the two notes. It is possible to obtain the effect with *Strum* by taking advantage of the fact that only the last note played is bended.

When the *Auto-Strum* mode is switched *on*, one first plays the note which should not be bended and then the second one. The bending effect is then obtained by moving the pitch wheel or using the aftertouch. This will only work, however, for intervals larger than one tone because otherwise *Strum* always automatically triggers a hammer-on or pull-off when intervals of one or two semi-tones are played legato.

When the *Auto-Strum* mode is switched *off*, the two notes can be played at the same time on the keyboard. The lowest is then triggered with the bass strumming key (E5) and the second note with the arp 4 key (G5). The note to be bended is triggered last and the bending is activated either using aftertouch or the pitch wheel.

4.4.7 Power Chords

Power chords are equivalent to playing a fifth interval. They are referred to as chords because they can also be interpreted as a major chord played without the third. In *Strum*, power chords are obtained by playing fifth intervals on the keyboard. When two notes are played simultaneously on the keyboard, *Strum* detects an interval and therefore plays the notes on different strings. It is not always possible to play notes simultaneously when playing live and it is therefore recommended to play the highest note of the interval slightly before the lowest. Otherwise, *Strum* may decide to play the highest note on the lowest string and then will also need to voice the lowest note on the lowest string which will result in both notes being played one after the other. A power chord voicing on three strings is obtained by playing the root, the fifth and the root again one octave higher on the keyboard.

Note that if you wish to obtain a power chord whenever a chord containing 3 or more notes is played on the keyboard, you can also set the chord type in the Chords/Loop section to *Powerchord* as explained in Section 4.6.

4.5 Using MIDI Loops

Reproducing complex patterns played on the guitar can rapidly become complicated and requires to be a good keyboard player. The good news, however, is that patterns, in other words sequences of chords and strumming keys, can easily be played using *Strum*'s MIDI loop player. Furthermore, *Strum* is supplied with a library of MIDI loops which you can use to easily start creating a new piece. The standard loop library is accessible directly from *Strum*'s interface by clicking on the *Load* button of the loop player which will automatically bring you to the default MIDI loop library folder. Loops can be used as they are or can easily be edited in a sequencer and then be played using the *Strum* MIDI loop player.

It is important to note that *Strum* makes no distinction between MIDI signal coming from the standard MIDI input (keyboard or sequencer) or the MIDI loop player. How *Strum* interprets the MIDI signal it receives therefore depends whether the *Auto-Strum* mode is *on* or *off*. When it is on, *Strum* will play chords as they are played on the keyboard and then trigger them again when strumming keys are played in the loop. It is therefore usually simpler to switch the *Auto-Strum*

mode *off*, chords are then triggered following the pattern of strumming keys in the MIDI loop. In other words, chords are plucked on the keyboard and strumming patterns are applied to them through the MIDI loop player. Note that loops are not limited to strumming keys and can also include melodies and chords.

4.5.1 Creating MIDI Loops

Loops for *Strum* are easily created in your favorite sequencer by respecting the following rules:

- All the events must be on MIDI channel 1.
- The loop must begin at the start of the file and finish at the end of the track. In other words, if the track lasts for four bars but there are notes only in the first bar, *Strum* will still loop over the four bars.
- The tempo and the time signature must be defined at the beginning of the loop and must not change during the rest of the loop. *Strum* indeed ignores tempo changes occurring in the middle of a loop.
- The loop must be recorded on disk on a file using MIDI format 0 or 1 and having a .mid extension.

Here are other advices which help to create more realistic loops:

- Always slightly vary the velocity of strumming keys in order to get a more lively result.
- If the loop is short, it may be preferable to repeat the same patterns many time with different velocities for each repetition.
- If the loop includes chords, always make sure that they are well quantized and that there is always a strumming key played at the same time. This will avoid unwanted strokes when the loop is played while the *Auto-Strum* mode is switched *on*.
- Avoid using MIDI controllers whose effect can be changed by the user. For example, the pitch wheel can either be used to create a bend or a slide; the hold pedal can either hold the current chord or be used to trigger an alternate strum.

4.5.2 Parameter Override Keyswitches

When playing a MIDI loop, the value of the currently loaded playing styles parameters located in the bottom part of the interface will be used to play the loop. It is possible that certain MIDI loop require specific values of these parameters in order to sound well. It is possible to set the value of these parameters in a MIDI loop with the help of special override keyswitches and ensure that a loop is always played exactly as intended by its creator. For the list of special override keys, please refer to Appendix B.

4.6 Chord Voicing

On the guitar, there are usually many different ways to play the same chord. Each of these positions or voicing sounds differently and suits different musical styles. The specific voicing chosen by *Strum* for a chord depends on the *Type* parameter from the *Chord* section of the interface. One can choose between three types of chords:

- **Open Chords.** These are chords played with a combination of fretted notes and open strings. These chords are usually played only within the first three frets of the fretboard. Open chords are easy to play and extensively used when playing folk music. Note that all chords do not necessarily have an open position on the guitar.
- **Movable Chords.** These chords do not use open strings. As a result they can be moved along the fretboard of the guitar allowing one to easily play the same voicing in different tonalities. This type of chords includes barre chords which are obtained by using one finger to press down multiple strings across the fretboard. Movable chords always use the maximum possible number of strings and are therefore useful to play arpeggios. Furthermore they allow one to play the same arpeggio patterns in different keys.
- **Drop Chords.** These are four note chords which allow for fast and subtle movement between chords. The positions used by *Strum* are based on drop 2 and drop 3 chords. These chords are obtained by dropping the second or third voice of a chord down one octave. Chords played on the keyboard with three notes will always be played on three strings by *Strum*. If the chord contains 4 or more notes, the corresponding voicing will always be played on four strings. This type of chord sounds lighter and is extensively used in jazz.
- **Powerchords** A power chord, also known as fifth chord, consists in a note and another one a fifth above. In other words it is like a triad without the third. Powerchords are extensively used in rock music especially with highly distorted sounds as including the third usually results in unpleasant frequency components in the distorted sound. They are also easy to play. In powerchord mode, any chord played on the keyboard which contains a natural fifth will be played with 3 notes: the root, the fifth and the octave. If the chord does not include a fifth only the root and the octave are played. If the chord is inverted on its fifth, the power chord played by *Strum* is also inverted and the notes played in the following order: fifth, root and octave.

In addition to these voicing categories, the voicing can be made more precise by specifying what should be the lowest note of the chord played by *Strum*:

- **Lowest.** The lowest note in the guitar voicing chosen by *Strum* is the lowest note played on the keyboard. This type of voicing is useful if it is necessary that the bass of the chord sequence follows a specific movement.
- **Root.** The lowest note in the guitar voicing chosen by *Strum* is the root of the detected chord. It is very common for guitar chords to have the root in bass position. This choice of chord

type allows one to play chords on the keyboard using any voicing and still obtain a guitar chord in root position.

Finally, the *Playing Position* parameter from the *Chord* section allows one to specify the lowest fret on which the lowest note of a chord should be played. This control gives *Strum* an indication of the position on the neck where chords should be played and chords are voiced accordingly when possible. This parameter is of course only valid for movable chords and it is therefore inactive when open chords are chosen.

Although there is no general rule and there are many ways to play in different musical styles or obtain different effects, we give some guidelines on chord types and performance settings which should work well in specific situations:

- **Folk.** Open-Root and medium strumming speed.
- **Country and Bluegrass.** Open-Root with a high strumming speed.
- **Pop-Rock.** Moveable-Root.
- **Arpeggios with bass motion.** Moveable-Lowest or Open-Lowest.
- **Jazz.** Drop chords.
- **Samba Bossa.** Drop chords. Use the arp 6 strumming key to play the bass and arp keys 4, 3 and 2 simultaneously to play the rest of the chord.
- **Funk.** Moveable-Root with *Playing Position* on a high fret.
- **Flamenco** Open-Root with a rapid strumming speed. Use the alternate strum on the four highest strings.

5 Presets and MIDI maps

Strum Electric comes with several factory presets covering a wide range of sounds. This collection of presets lets you play and familiarize yourself with this synthesizer without having to tweak a single knob. Soon, however, you will be experimenting and creating your own sounds and projects that you will need to archive or exchange with other users. You may also want to control the parameters of *Strum Electric* with a specific MIDI controller. In this chapter, we will review the management of presets and MIDI maps.

5.1 Presets

There are two concepts involved in the management of presets, the preset library and programs.

5.1.1 The Preset Library

The preset library contains the factory presets, modified versions of the factory presets you might have made or any other new presets you might have saved. The library may also contain imported presets as well as MIDI maps as explained in Section 5.6 and 5.7. In other words, the preset library is a repository of all the presets and MIDI maps available to *Strum Electric*.

All the operations on the preset library are conveniently managed with the help of the *Strum Electric* browser, similar to those found in most email programs which use a hierarchical tree structure and a visually intuitive, drag and drop approach. To explore the different presets available in the library, open the different folders by clicking on the “+” icon Windows or ► symbol on Mac OS to the left of folders.

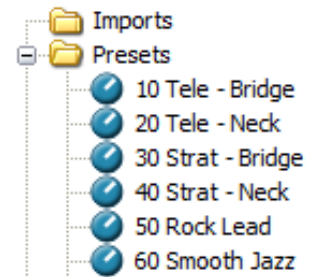

There are two different types of presets in *Strum Electric*, instrument presets and playing styles presets. Instrument presets are represented by blue icons and contain settings for all the parameters on the graphical except those included in the lower or performance section of the interface. In other words, they include all the parameters corresponding to the guitar the amplifier, the effects and the reverb modules. Playing styles presets are represented by yellow icons and include settings for the lower or performance section of the interface exclusively. The idea behind these two types of

presets is to allow one to easily change all the parameters affecting the sound of the instrument without modifying parameters associated with performance and MIDI. These parameters are usually adjusted once for a given musical or playing style while it is usually necessary to try different guitar/amplifier combination before finding the right sound.

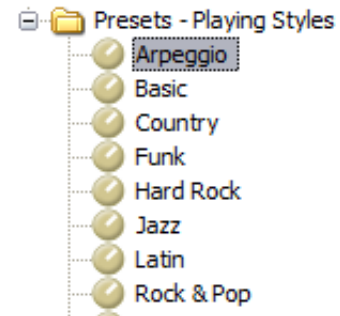

5.1.2 The Program list

Presets are loaded into the synthesis engine of *Strum Electric* from a list of 128 numbered presets called programs. The name of the current program and its number are displayed in the left of the toolbar at the top of the application window. The entire list of programs can be viewed by clicking on the ▼ button left of the program number.

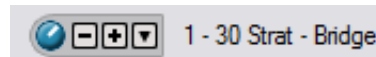

It is important to note that presets in the program list and in the preset library are stored in different locations. They are in fact different copies of the same presets which may, as explained below, differ even if they share the same name. The version of a preset available in the program list should be viewed as temporary or as a ‘working copy’ of the preset whereas the version in the library should be viewed as permanent or as the ‘reference version’.

When you start the application for the first time, the program list contains a selection of presets from the factory preset library. At that point, the presets in the program list are identical to their version in the library.

One more important to know about programs is the fact that in addition to an instrument preset (guitar, amplifier and effect section) they also include the settings of the parameters of the lower or performance section. This allows one to load all the parameters of the interface at once for example using MIDI program changes.

5.2 Playing and Changing Presets

Presets are always played from the program list. The name of the current program, in other words the one currently loaded in the synthesis engine, as well as its number are displayed in the left part of the toolbar. Its number and name are also preceded by a check mark in the program list. The current program can be changed in different ways:

- scroll up or down in the program list by clicking on the ‘+’ and ‘-’ buttons located on the left of the program name or use the ‘+’ and ‘-’ keys from the computer keyboard,
- Display the content of the program list by clicking on the ▼ button and select a program by clicking on its name.
- Use the **Switch to Program** command from the **Programs** menu and enter a specific program number. This command can also be activated by using the Ctrl-P/Apple-P keyboard shortcut.
- Send MIDI program changes from your MIDI controller. *Strum Electric* will load the program having the same number as the program change number received by the application.

A Preset can also be loaded from the preset library. It is then stored in the current program replacing the preset that was already stored in this location. It then becomes immediately available to the synthesis engine. Different options are available to load a preset from the preset library into the current program:

- In the browser, double-click on a preset icon.
- Drag and drop presets from the browser onto the *Strum Electric* interface.
- Select a preset by clicking on its icon and use the Enter key from the computer keyboard. Once a preset has been selected in the library, it is possible to navigate in the library using the Arrow keys from the computer keyboard. A preset is selected when its name is highlighted.
- Select a preset and use the **Open Preset** command from the **File** menu or the Ctrl-O/Apple-O keyboard shortcut.

Note that when a preset is loaded from the preset library to the list of programs, the program name displayed in the toolbar changes but not its number. This indicates that the current program number used by the synthesis engine is still the same but that the preset corresponding to that program has changed. The 128 programs can therefore be customized by selecting different program numbers (by using the ‘+’ and ‘-’ buttons from the toolbar or selecting programs from the program list) and loading presets from the library.

5.3 Editing and Saving Presets

Moving the different controls on the *Strum Electric* interface modifies the preset loaded in the current program. As soon as the current program is modified, the preset icon located on the left of the program name in the toolbar changes color and a ‘*’ sign is appended to its name in the program list. In this state, the preset loaded in the current program is different from its original version stored in the preset library even if they share the same name. If you wish to keep a permanent copy of the modifications, you must save this new version in the preset library.

- To save the new version in the preset library, use the **Save Preset** command from the **File** menu or the Ctrl-S/Apple-S shortcut. Be careful, however, as using this command will overwrite the original preset. If you are not certain of which preset will be overwritten in the library, first use the **Locate Program in Browser** command from the **Programs** menu or the Ctrl-L/Apple-L shortcut in order to locate it in the browser.
- To create a new preset, use the **Save Preset As** command from the **File** menu. A window will appear asking for a name for the new preset. Once the preset is saved using this command, a new preset icon will appear in the browser directly under the **Library** folder.
- To create a new preset, it is also possible to rename the program using the **Rename Current Program** from the **MIDI** menu (or the Ctrl-R/Apple-R keyboard shortcut) and use the **Save Preset** or **Save Preset As** commands.

When editing presets, it is very helpful to go back and forth between the different stages of your modifications and adjustments. To move back step by step through every modification that was applied to a preset, use the **Undo** command from the **Edit** menu or the Ctrl-Z/Apple-Z shortcut. Once the **Undo** command has been used, it is also possible to move up again through the modifications

by using the **Redo** command from the **Edit** menu or the Ctrl-Y/Apple-Y command. The number of **Undo** levels is unlimited and this command is effective on any control of the interface but not on the different **Save** commands.

Once a preset has been modified, it is also possible to move back and forth between the current state of the preset in the program list and its original version archived in the preset library. To hear the original preset, simply click on the *Compare* button at the top of the interface or use the **Compare** command from the **Edit** menu. Once this button has been pressed, the original settings of the preset are loaded. In this mode, the graphical interface is frozen and it is therefore not possible to modify the preset. To further modify the preset, click on the *Compare* button again or uncheck the **Compare** command in the **Edit** menu to revert to the modified version of the preset and unfreeze the interface. To reload the original version, use the **Locate Preset in Browser** command from the **View** menu, or the Ctrl-L/Apple-L shortcut and double click on its icon in order to reload this version into the current program.

Strum Electric will make sure that you do not lose modifications to a preset. In the case where a program holds a modified version of a preset and when trying to load a new preset from the library into this program, the application will ask you if you want to save the modified preset in the library. This behavior might not always be convenient and it is possible to deactivate it by deselecting the **Ask to save preset before opening another** option in the **Preferences** command from the **Edit** menu.

5.4 Saving the Program List

When you open *Strum Electric*, the application always loads the same program list. This implies that, by default, the program list will always contain the same presets when you open the application and that your modifications to presets will be lost unless they have been saved in the preset library.

- To save the current list of programs and replace the default program list, use the **Save All Programs** command from the **Programs** menu.

This command is helpful if you wish to modify the program list or if you wish to restart the application in exactly the same state as when you left it.

Note that this operation is not necessary when using *Strum Electric* as a plug-in in a host sequencer as the program list is always saved with a project. The default program list will be loaded only if a new project is started or if a new instance of *Strum Electric* is opened within a project.

5.5 Organizing the Preset Library

5.5.1 Creating Folders

Sub-folders can be created by first selecting a folder by clicking on it and using the **New Folder** command from **File** menu.

5.5.2 Copying and Moving Presets and folders

Presets and folders can be copied and moved from one location to another. First select an item by clicking on its icon and use the **Copy** command from the **Edit** menu (Ctrl-C/Apple-C shortcut) in order to copy it. Then click on the destination folder and use the **Paste** command from the **Edit** menu (Ctrl-V/Apple-V shortcut) in order to paste it. Groups of items can be copied and pasted at the same time. In order to select many items at once, click on different icons while keeping the Control/Apple key depressed. Alternatively to select, within a folder, all the presets located between two presets, click on the first one and then on the second one while keeping the Shift key depressed. Once a group of items has been selected, use the **Copy** and **Paste** functions as explained above.

5.5.3 Renaming Presets and folders

On Windows systems, to rename a preset or folder, click a first time on the corresponding icon in the browser in order to select it. Then click a second time to enter in name edition mode. Note that this sequence of operation is different from double-clicking on the icon which loads the preset in the case of a preset icon or opens a folder in the case of a folder icon. In other words, there must be a pause between the two clicks.

On Mac systems, first select the item to be renamed and then use the **Rename** command from the **Edit** menu. It is also possible to ctrl-click on the selected item and then choose the **Rename** command.

5.5.4 Deleting Presets and Folders

To delete a preset or folder, first select it by clicking on its icon in the browser, then use the **Delete** command from the **Edit** menu or use the Del key from the computer keyboard. In order to select and then delete many items at once, click on different icons while keeping the Control/Apple key depressed. Alternatively to select, within a folder, all the presets located between two presets, click on the first one and then on the second one while keeping the Shift key depressed. Once the group of items has been selected, use the **Delete** function as explained above.

5.5.5 Documenting Presets

It is possible to document a preset and view related information. To view or edit information on a preset, first select it in the browser and choose the **Preset Info** command from the **Edit** menu or use the Ctrl-I/Apple-I shortcut. It is also possible to right-click/control-click on the preset icon and choose the **Preset Info** command. Information on a preset includes the author's name, copyright notice, date of creation, last modification date and a text description.

5.5.6 Locating a Preset in the Browser

It might sometimes be helpful to locate in the preset library the preset currently being played or in other words, that corresponding to the current program. To rapidly locate the current preset in the browser, use the **Locate Program in Browser** command from the **Programs** menu or the Ctrl-L/Apple-L shortcut. The **Locate** command will automatically expand the folder containing the currently used preset and select the preset.

5.5.7 Resizing the Browser

In standalone mode, the browser can be resized. In order to change the size of the browser, position the mouse cursor on the line separating the browser from the *Strum Electric* control panel. When the cursor changes to a double-headed arrow, click-hold and move the mouse to the left or right as desired. In order to hide the browser completely, move the double-headed arrow cursor fully to the left. Note that when *Strum Electric* is used as a plug-in, the browser size is fixed and can not be modified.

5.6 MIDI Maps

MIDI maps containing information about MIDI links between the MIDI controllers and the *Strum Electric* interface can easily be created as will be explained in Section 9.2. MIDI maps are represented in the browser with a MIDI connector icon. MIDI maps are treated exactly the same way as presets in the browser and are saved using the **Save MIDI Links** or **Save MIDI Links As** commands from the **File** menu.

5.7 Exporting and Importing Presets and MIDI maps

The **Import** and **Export** commands, found in the **File** drop down menu, allow one to easily exchange presets and MIDI maps with other *Strum Electric* users. This feature can also be used to decrease the number of elements in the browser by archiving older or rarely used ones elsewhere, on CD-R, or a second hard disk for example. Files containing *Strum Electric* presets and MIDI maps are equivalent in size to short text file, making it easy to send presets to other users via email.

To export a folder, a group of folders, presets or MIDI maps within a folder, select the elements to export in the browser and use the **Export** command from the **File** menu. When the **Export** window appears, choose a file name and a destination location on your hard disk. *Strum Electric* export files will be saved with an “strumA” extension.

Importing presets and MIDI maps is just as easy. Simply click on the **Import** command from the **File** drop down menu, and select the file to import. A new folder will then appear under the **Imports** directory in the browser, containing all of the files contained within the imported package. These can then be dragged and dropped to a new folder, or remain in the Imports directory.

5.8 Backup Presets and MIDI Maps

There are basically two ways to backup your presets and MIDI maps: exportation and database backup. The database backup is more efficient when there is a large number of elements to backup.

The exportation methods consists in using the **Export** command from the **File** menu as explained in section 5.7. Once you have exported the elements you wish to archive, just save the export file(s) to your usual backup location or medium.

The second backup method will enable you to archive the entire material present in the browser. The content of the browser, including presets, MIDI maps and folders is saved into a database file. This second backup method simply consists in archiving this file. The database file location is different whether you are working on a Mac OS or Windows system.

- On **Windows** systems: C:\Documents and Settings\[User]\Application Data\Applied Acoustics Systems\Strum Electric 1.0.
- On **Mac OS** systems: [System Drive]:Users:[User]:Library:Application Support:Applied Acoustics Systems:Strum Electric 1.0.

The name of the database file is StrumElectric.tdb. In order to archive your database, just copy this file to your usual backup location or medium. In order to restore a database, replace the version of the StrumElectric.tdb file with a previously archived one. It is also possible to synchronize different systems by copying this file on different computers where *Strum Electric* is installed.

5.9 Restoring the Factory Presets and MIDI Links

If necessary, it is possible to restore the original factory library and program list by using the **Restore Factory Library** from the **File** menu. This operation makes a backup of your current database file in the preset database folder as explained in Section 5.8 and creates a new preset database containing only the factory presets and MIDI maps. The next time you open *Strum Electric*, both the browser and the program list will be in exactly the same state as when you first installed the application.

Note that restoring the factory library should be done with caution as you will loose all the work you might have saved into the library and that this operation can not be undone easily. If you wish to recuperate a certain number of presets and MIDI maps after restoring the factory library, we recommend that you first export all the material you wish to keep using the **Export** command as explained in Section 5.7. After re-installation of the factory library, you will easily be able to re-import this material using the **Import** command.

If you forgot to export material before restoring the factory library or if you wish to bring back the preset library to its state before restoring the factory library, it is still possible to recover material from the backup file of the preset database which was created automatically when restoring the factory library as explained in Section 5.8. This method should be considered as a last resort,

however, as recovering material from this backup file will remove the factory library which you have just installed and force you to redo the operation. Using the Export command before restoring the factory library is much simpler.

Note that the restore of the factory library is actually performed the next time you re-open the application. It is still possible to cancel this operation before exiting the application by using the **Cancel Library Restore** command from the **File** menu.

6 Parameters

This section can be used as a reference on the different controls appearing on *Strum*'s graphical interface. We begin by describing the behavior of the different types of controls appearing on the interface

6.1 General Functioning of the Interface

6.1.1 Tweaking Knobs

All the knobs on the interface are selected by clicking on them. Once selected, they can be controlled in different ways depending on the effect you want to achieve.

- For coarse adjustment click-hold on a knob and drag the mouse upwards or downwards to move it clockwise or counter-clockwise.
- For fine adjustment, use the left or down arrow of the computer keyboard to move the knob counterclockwise and the right or up arrow to move it clockwise. The **Page Up** and **Page Down** keys give the same result with slightly faster action.
- To move a knob to a given position, place the mouse at this position and Shift-click (Windows) or Option-click (Mac OS). To reach this position slowly, do the same, but use the middle button of the mouse (Windows only).
- Knobs with bi-directional arrows in the middle of their contour can be adjusted directly to their center position by double-clicking on them.
- When viewing parameters for individual strings, it is possible to set the value of a parameter for all strings at once. To do so, Ctrl-click (Windows) or Command-click (Mac OS) on a knob and move it.

Remember that the keyboard shortcuts affect only the most recently selected control. The value of the control currently selected is displayed on the toolbar at the top of the *Strum* window. The number displayed on the counter is a value corresponding to the current value of the corresponding parameter.

6.1.2 Buttons

Buttons are switched *on* or *off* by clicking on them. The status of a button currently selected is displayed in the toolbar.

6.1.3 Drop-down Menus and Displays

Clicking on a display with a small down-pointing triangle on its right, such as the *Type* control of the **Multi-Effect** module, reveals a drop-down menu with a set of possible settings for the control. Adjustment of the control is obtained by clicking on a selection or using the up and down arrows and the **Enter** key of the computer keyboard.

6.1.4 Bypassing a Module

The different effect modules of *Strum* can be turned *on* or *off* by clicking on the button appearing on the right of the module label. A module is active when the button is in its *on* position and is lit. Note that when a module is **not** activated, calculations associated with this module are not performed, reducing CPU usage.

6.1.5 Modulation Signals

Some parameters, such as the *Speed* parameter from the *Strumming* section, can be modulated with MIDI velocity. When it is the case, a *Velocity* knob appears below the parameter and both knobs are linked by a thin vertical line.

6.2 The Guitar Modules



This is the main view of the instrument and is activated when the *All* button, located in the upper left corner of the guitar shape, is switched *on*. In this mode the different modules forming the guitar are visible, each with a few control parameters. This mode is used to play the different presets and, if necessary, easily make adjustments. Only a selection of the parameters actually used by the synthesis engine are visible in this view. The full range of parameters for each string is accessible by clicking on the numbered buttons next to the *All* button, each representing a string number. These different parameters are described in section 6.5.

The **Pick/Fingers, Strings, Hammer-On, Palm-Mute** modules are related to the modeling of the individual strings of the guitar. The **Pickups** module on the right of the guitar shape represents the action of pickups and allows one to adjust their volume and select different combinations of pickup positions. The different knobs in this view are so-called *offset* knobs. Each of them is related to a specific parameter of the strings or body of the instrument. They are used to vary the value of a parameter around its current value, in other words the value visible when selecting individual strings. In the case of the strings parameters, these offset knobs alter the value of the same parameter for the six strings at once.

Note that after varying parameters with these offset knobs, it is possible to apply the changes to the parameters. This is done by clicking on the down-pointing arrow located on the right of the module labels and selecting the *Apply Offset* command. This will add the offset value to the current value of the parameter, move back the offset knob to its center position and update the knob position in the individual string views.

6.2.1 The Strings Module

In an electric guitar, it is the vibration of the strings which is captured by the pickups and converted into an electric current. It is also the strings that fix the pitch of the sound we hear depending on their effective lengths.

The *Tone* knob controls the decay time of high frequencies in the sound relatively to that of low frequencies which is a parameter related to the material of the string. Turning this knob clockwise enhances high frequencies resulting in a more metallic sound while turning the knob anti-clockwise has a damping effect on high frequencies.



Strings are usually considered to be harmonic meaning that all the frequency components of the sound appear at frequencies that are multiple integers of the fundamental frequency of the note being played. Real strings, however, are not perfectly harmonic due to the fact that their width is not exactly constant along their entire length. As the inharmonicity is increased, we will say that the sound becomes more and more dissonant. In *Strum*, the amount of inharmonicity in the sound is controlled using the *Inharm* knob. Turning this knob clockwise detunes the partials toward higher frequencies while turning it anti-clockwise reduces the inharmonicity of the strings.

The *Coupling* knob is used to control the amount of beating in the sound. Turning this knob to the right increases the amount and frequency of the beating while turning it to the left reduces it. This beating effect is characteristic of real guitar strings, it is due to the coupling between two different components in the motion of the string as will be explained in more details in Section 6.5.1 hence the name of this knob.

6.2.2 The Pick/Fingers Module

The *Pick/Finger* module allows one to control the excitation of the string with a pick or fingers. The *Edge* parameter is used to control the rounding of the edge of the plectrum. Turning this clockwise increases the sharpness of the edge resulting in a brighter sound. The *Position* parameter allows one to modify the pick position on the strings while playing. This is a parameter used by guitarists to change the tone of the sound. Indeed playing near the bridge results in a dryer and more metallic sound while playing over the hole of the body or toward the fretboard results in a fuller sound. In its leftmost position, the pick is very close to the bridge. Moving this knob clockwise moves the pick toward the fretboard.



6.2.3 The Hammer-On Module

The *Hammer* module is used to control hammer-on and pull-off effects. Hammer-ons and pull-offs are playing techniques used by guitar players to play legato or grace notes. The hammer-on effect is obtained by first picking a note and then hammering down another finger onto the same string at a higher fret. The pull-off effect is almost the opposite of the hammer on. It is obtained by first picking a note and then sharply pulling-off the finger from the fretboard in order to hear a second fretted note on the same string. The sounds produced using these techniques are softer and less percussive than the ones produced by picking the notes.



In *Strum*, hammer-ons and pull-offs are triggered when legato playing on the keyboard is detected. The *Amp* knob is used to control the amplitude of the excitation when a hammer-on or pull-off is triggered and therefore determines the strength of the effect. Turning this knob to the left reduces the amplitude of the excitation while turning the knob clockwise increases it.

6.2.4 The Palm-Mute Module

Palm muting is a technique used by guitar players to muffle the strings slightly while simultaneously playing the strings with the picking hand. It is obtained by letting the side of the picking hand touch the strings just before the bridge.

In *Strum*, palm muting is achieved by using special strumming keys as explained in section 3.2. The resulting sound of this effect can be adjusted with the help of the *Tone* knob. This parameter is used to control the amount of high frequencies in the resulting sound; turning this knob to the left decreases the amount of high frequencies relatively to low frequencies while turning it to the right increases it.



6.2.5 The Pickups Module

The pickups of an electric guitar are an essential part of the instrument. They are transducers able to capture the mechanical vibrations of the strings and transform them into an electric current which is then routed to an amplifier and speaker. An electric guitar usually has two or more pickups located at different points on the body each with its distinctive sound. Pickups can be activated individually or paired to produce different tone colors.

A magnetic pickup consists of a permanent magnet wrapped into a coil of several hundred turns. The vibrations of the metal strings close to the pickup result in a modulation of the magnetic field surrounding the coil which induces an alternative current in the wire of the coil. The electric signal from the pickup is sent to the amplifier via a simple electric circuit and a cable. The combined inductance, capacitance and resistances of this circuit form a resonant low-pass filter whose cut-off frequency and volume can be controlled through the use of potentiometer by the musician.



The **Pickup** module of *Strum* include two controls in the main view. The *Selector* control allows one to select which pickup is activated. Available positions are neck (N), body (B) or both simultaneously (+).

The *Volume* knob is used to adjust the overall level of the output from the guitar. It is important to note that while changing the volume of the output signal does not affect the sound of the guitar itself, it does affect the sound of the guitar, amplifier chain. Indeed, a key element of the tonal effect of the amplifier is the distortion it introduces in the signal which strongly depends on the amplitude of the input signal of the amplifier. This means that adjusting the output level of the guitar to values which are too high will result in an output signal from the amplifier which is always distorted. In order to maximize the dynamic range of the amplifier, the output signal from the guitar should be adjusted to the 0 dB mark on the level meter when playing at mezzo forte and when the amplifier, the spring reverb, and the cabinet are switched *off*.

6.3 The Amplifier Module



Strum Electric is equipped with a versatile 2-channel amplifier with speaker cabinet and spring reverb. With relatively few parameters, this amplifier module allows one to obtain a rich variety of sounds for different music styles.

The amplifier section of this module is switched *on* or *off* using the first *On* button located at the top of the module. The *Channel* selector allows one to switch between the two channels of the amplifier. Channel one offers clean to semi-dirty sound while channel two is well-suited when strong distortion is required. The *Drive* knob is used to adjust the amount of distortion in the sound. The sound becomes more and more distorted as the knob is turned clockwise. The *Mid* knob is used to set the amount of mid-range frequencies in the sound. In its middle position, the sound is not modified, mids are cut or boosted by up to ± 12 dB by turning this knob to the left or right. The *Level* knob is a gain knob which is used to adjust the overall volume of the amplifier. Note that the effect of this control on the frequency response of the amplifier is different for each channel.

The *Low* and *High* parameters are used to boost or cut low and high frequencies respectively by up to *pm* 18dB by turning the knob from its center position. These controls have a similar behavior for both channels. Additional control on the frequency response is obtained by using the *Byte* control which is switched *on* or *off* by clicking on the *B* button next to the channel selector. This parameter boosts high frequencies while cutting some low frequencies for a brighter sound.

The second *On* button is used to switch *on* or *off* the spring reverb. The *Spring* knob is used to set the amount of wet signal in the mix, turning the knob clockwise increasing the amount of reverberation in the signal.

Finally, the speaker cabinet is switched *on* or *off* by clicking on the last *On* button in the upper right corner of the module. This part of the module simulates the effect of both the speaker and the cabinet on the frequency response of the amplifier module. The back of the cabinet can be open or closed using the *O* and *C* button of the *Cabinet* selector. Opening the back of the cabinet allows waves to travel from the back of the cabinet and interfere with those traveling from the front part of the cabinet resulting in a more colored sound.

The low-cut (or high-pass) filter is used to remove from the output sound of the instrument frequency components below the cut-off frequency. The cut-off frequency of the filter is increased by turning the knob clockwise. when this knob is in its leftmost position, the filter has no effect on the sound.

6.4 The Multi-Effect Module

The **Multi-Effect** module allows one to process the output signal from the guitar and the amplifier. There are in fact two sets of effects, a first one called *Pre* which can be applied before the amplifier and a second one, *Post*, which can be used for processing the output from the amplifier. The *Pre* and *Post* effects are activated by switching *on* or *off* by clicking on the corresponding *On* button.

The effect applied in *Pre* or *Post* configuration is selected from the *Type* drop-down menu. Available effects include three different types of delays (ping pong, digital and tape), chorus, flanger, phaser, auto wah, wah wah, notch filter and tremolo.

The different effects can be synchronized to the clock of a host sequencer using the *Sync* drop-down menu. Sync values range from 1/8 of a quarter note (a thirty-second note) to 16 quarter notes (4 whole notes) where the duration of the whole note is determined by that of the sequencer clock. The effect can also be synced to a triplet (t) or dotted note (d).

Each of the effect of the module can be controlled using three offset knobs. When in their center position, the effect is adjusted according to the factory settings. Turning the knobs to clockwise or anti-clockwise allows one to deviate from this default setting as described below.



6.4.1 Delay

The Multi-Effect module includes 3 different types of delay effects: *Ping Pong*, *Digital* and *Tape Delay*. The *Digital* delay consists in a standard delay line with feedback. The tape delay is similar but also includes a low-pass filtering effect in order to simulate the attenuation of high frequencies in analog tape delays. The *Ping Pong* delay is based on two delay lines resulting in a signal traveling from one channel to the other, each time attenuated by a coefficient.

The *Wet* knob is used to adjust the amount of “wet” signal present in the output signal from the effect. When the knob is adjusted in the left position, only the original or “dry” signal is sent to the output. Turning this knob clockwise increases the amount of processed or “wet” signal sent to the output. In its rightmost position, only “wet” signal is present in the output signal. The *Feedback* knob is used to adjust the amount of signal re-injected into the delay lines or in other word the amount of feedback introduced in the line. In its leftmost position, there is no signal re-introduced and the effect module only delays the input signal. Turning this knob clockwise increases the amount of signal reflected back at the end of the line. Finally the *Time* knob controls the length of the delay lines and therefore the delay between echoes.

6.4.2 Chorus

The **Multi-Effect** module includes both a mono and stereo *chorus* effect. The chorus effects can be controlled with the three knobs appearing at the bottom of the module. The *Mix* knob is used to

adjust the ratio of “dry” and “wet” signal in the output signal from the module. When the knob is adjusted in the left position, only the original or “dry” signal is sent to the output while in the right position only the processed or “wet” signal is sent to the output. The *Depth* knob is used to control the amplitude of the effect while the *Rate* knob is used to fix the modulation frequency of the effect if the *Sync* function is *off*.

6.4.3 Flanger

The **Multi-Effect** module includes both a mono and stereo flange effect. The *flanger* effects can be controlled with the three knobs appearing at the bottom of the module. The *Mix* knob is used to adjust the ratio of “dry” and “wet” signal in the output signal from the module. When the knob is adjusted in the left position, only the original or “dry” signal is sent to the output while in the right position only the processed or “wet” signal is sent to the output. The *Depth* knob is used to control the amplitude of the effect while the *Rate* knob is used to fix the modulation frequency of the effect if the *Sync* function is *off*.

6.4.4 Phaser

The “phasing” effect colors a signal by removing frequency bands from its spectrum. The effect is obtained by changing the phase of the incoming signal and adding this new signal to the original.

The phaser effects can be controlled with the three knobs appearing at the bottom of the module. The *Mix* knob is used to adjust the ratio of “dry” and “wet” signal in the output signal of the module. When the knob is adjusted in the left position, only the original or “dry” signal is sent to the output while in the right position only the processed or “wet” signal is sent to the output. The *Depth* knob is used to control the amplitude of the effect while the *Rate* knob is used to fix the modulation frequency of the effect when the *Sync* function is *off*.

6.4.5 Wah

The Multi-Effect module includes 2 different types of wah effects: wah wah, and auto wah. Both of them are based on a specially designed bandpass filter with a 12 dB/oct slope. In the wah wah effect, the center frequency of the bandpass filter varies at a certain rate. In the case of the auto-wah, the variations of the center frequency is controlled by the amplitude envelope of the incoming signal.

The *Freq* knob is used to control the central frequency of the filter. Turning this knob clockwise increases the center frequency. In the case of the *Wah Wah* effect, the center frequency will oscillate around the value fixed by the *Freq* knob while with the *Auto Wah* effect, the setting of the *Freq* will fix the starting point of the value of the center frequency.

The *Depth* knob controls the excursion of the center frequency of the filter. In the case of the *Wah Wah* effect, this excursion is applied around the value fixed by the *Freq* knob while in

Auto Wah effect the value of the center frequency increases from the value fixed by the *Freq* knob. Turning this knob clockwise increases the excursion of the center frequency.

Finally, the *Rate* knob controls the frequency or rate of the modulation of the center frequency of the filter. In the case of the *Wah Wah* effect, turning this knob clockwise increases the rate of the modulation if the *Sync* function is *off*. In the case of the *Auto Wah* filter, this knob controls the time constant of the envelope follower. Turning this knob clockwise decreases the time constant, or in other words the reaction time, of the envelope follower.

6.4.6 Notch Filter

The *notch filter* does essentially the opposite of a band-pass filter. It attenuates the frequencies in a band located around the center frequency and leaves those outside of this band unchanged as shown in Figure 22. As was the case for the *Wah Wah* effect, the filter is based on a filter having a 12 dB/oct slope and can be modulated.

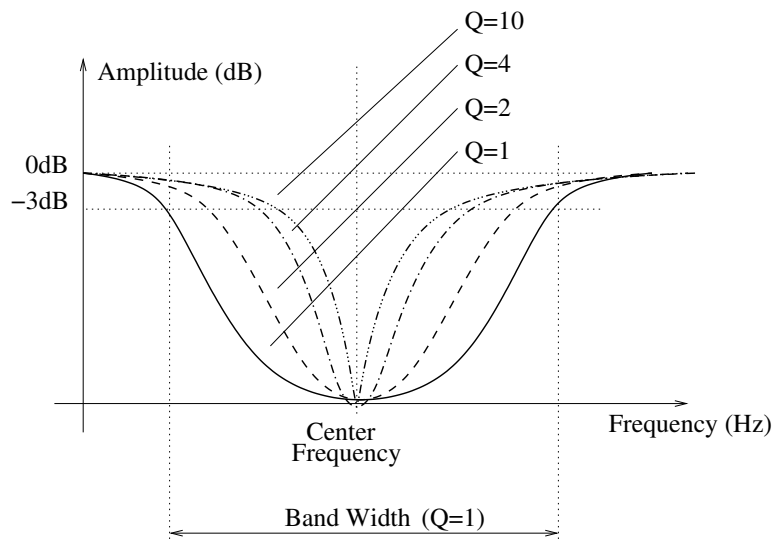

Figure 22: Frequency response of a notch filter.

The *Freq* knob is used to control the central frequency of the filter. Turning this knob clockwise increases the center frequency. The *Depth* knob controls the excursion of the center frequency of the filter around its center frequency. Turning this knob clockwise increases the excursion of the center frequency. Finally, the *Rate* knob controls the frequency or rate of the modulation of the center frequency of the filter. Turning this knob clockwise increases the rate of the modulation if the *Sync* function is *off*.

6.4.7 Tremolo

The *Tremolo* effect introduces a low frequency modulation of the amplitude of the sound. When the effect is used in stereo mode, the sound also bounces with a 180 degree phase shift from left to right. The *Shape* parameter is used to adjust the shape of the waveform which creates the tremolo effect. In its leftmost position, the wave is triangular while in its rightmost position it is a square wave. The *Depth* parameter is used to set the amount of modulation in the amplitude of the signal. In its leftmost position, the amplitude is not modulated and turning the knob clockwise gradually increases the amplitude of the modulation. Finally, the *Rate* knob is used to control the frequency of the modulation. Turning this knob clockwise increases the frequency and therefore results in a faster modulation rate. Note that this knob is active only when the *Sync* function is switched off.

6.5 Edit Mode



Figure 23: Editing parameters for string number 6 (E2).

This mode allows one to view and adjust all the parameters used by the synthesis engine. While for most applications, simply using the presets will be sufficient, one might want in certain cases to access the different instrument parameters and control them precisely. This mode is activated by clicking on one of the string numbers appearing in the top of the guitar shape. Strings are numbered from 6 to 1 with 6 being the lowest string (E2) and 1 being the highest one (E4). Clicking on the different string numbers reveals parameters for this specific string which implies that all strings can be tuned independently.

It is important to know that parameters from the different parameter sections can be copied from string to string or all of them at once by clicking on the down-pointing arrow located next to the section name label and choosing one of the proposed destination. Remember also that a specific parameter can be adjusted for all the strings simultaneously by ctrl-clicking (Windows) or Command-clicking (Mac OS) on the corresponding knob and moving it.

Finally, note that some of the parameters are framed by a lighter color background. This simply means that these parameters can be controlled from the general view obtained when clicking on the *All* button.

6.5.1 The Strings Module

The vibrational motion of a string can be decomposed into two different components, one perpendicular to the plane of the body of the guitar and the other one parallel to that plane. At the bridge, the string is fixed and energy is transferred to the body of the guitar but also exchanged between these two components of the string motion. This exchange is responsible for both the characteristic beating effect present in the sound of the guitar and the typical decay curve or envelope of the sound. Both these motion components are modeled in *Strum* and they are referred to as polarity *A* and *B*.

For each polarity, one can adjust three parameters called *Decay*, *Tone* and *Inharm*. The *Coupling* knob is used to adjust the amount of energy exchanged between the two polarities of the string motion. Turning this knob clockwise increases the coupling and therefore the amount and frequency of the beating in the sound. When this knob is in its leftmost position, there is no coupling between the two polarities. Both of these components exist but completely independent of each other resulting in a sound with no beating and a regular decay envelope. The *Balance* knob is used to control the mix between both polarities in the output sound. In its leftmost position, one only hears polarity *A* while in its rightmost position only polarity *B* is heard. In its middle position, an equal mix of both is heard.



In general, to get the most realistic realistic sound, the knob should be turned toward the left or in other words one should listen more to polarity *A*. This is because in a real guitar, vibrational motion perpendicular to the body is more efficiently transmitted. Interesting effects can however be obtained by mixing both polarities. Note that even when the balance knob is fully turned to the left, coupling between both polarities is still taken into account as soon as the *Coupling* knob is turned to the left which will introduce beating in the sound of polarity *A*. The *Volume* knob is a gain knob which is used to adjust the volume of individual strings.

The *Tone* knobs are used to set the respective amount of high frequencies in polarity *A* or *B* of the string motion with respect to low frequencies. In their leftmost position, the decay time of high frequencies in the sound is lower than that of low frequencies; in their rightmost position it is longer. The overall decay time of the vibrations is controlled with the help of the *Decay* knobs and it is increased by turning the knobs clockwise.

In a first approximation, the strings of a guitar can be considered to be harmonic meaning that their partials are located at frequencies equal to multiples of its fundamental frequencies. Real strings, however, are more or less inharmonic depending on the homogeneity of the strings along their length. This characteristic of strings is adjusted, for polarities *A* and *B*, with the *Inharm* knobs.

When these knobs are turned fully to the left, the string vibration is perfectly harmonic. Turning the knobs clockwise increasingly detunes the partials toward higher frequencies resulting in a more dissonant sound.

6.5.2 The Pick/Fingers Module

The *Pick/Finger* module allows one to control the parameters related with the excitation of the string. It can simulate the excitation of the string with a pick or with a finger. Three different pick/finger or plectrum models are implemented in *Strum* as shown in Figure 24, 25 and 26 each of them corresponding to a different plectrum profile. The first two models are better to simulate the interaction of the string with a hard pick while the third one is better to simulate the interaction with a smoother object such as a smooth pick or a finger. The plectrum model is chosen using the *Type* selector.

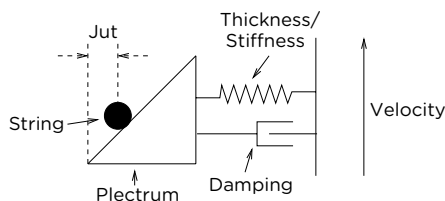

Figure 24: First pick model

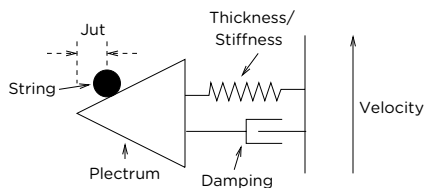

Figure 25: Second pick model

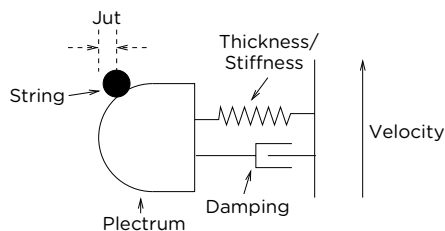

Figure 26: Third pick model

The excitation force produced by the plectrum when interacting with the string is determined by the *Jut*, *Speed*, *Stiffness* and *Damping* parameters. The *Stiffness* and *Damping* parameters determine the flexibility of the plectrum or in other words the resistance it exerts against the string. Increasing the value of these parameters will mainly increase the amplitude of the sound. The *Stiffness* parameter is used to control the stiffness of the plectrum used. Increasing this parameter, by turning the knob clockwise, results in thicker or stiffer plectrum. The *Damping* parameter controls the amount of damping in the plectrum. The parameter is mainly effective during the attack of notes. Raising its value, by turning the *Damping* knob clockwise, results in additional impact noise when the plectrum first comes into contact with the string when attacking a note. These two parameters are modulated with the note velocity through the use of the *Velocity* knob. When the knob is in its leftmost position, there is no modulation from the MIDI note velocity; turning this knob clockwise gradually increases the amount of modulation.



The *Jut* parameter enables one to control the distance between the edge of the plectrum and the string when they come into contact. In other words it simulates how far behind the string, a guitar player introduces the plectrum before picking the string. This parameter affects the loudness and the spectral content of the sound as well as the interaction time between the plectrum and the string. This parameter can also be modulated with the MIDI note velocity signal using the *Velocity* knob below. The *Speed* knob is used to control the speed of the plectrum relatively to the string. The main effect of this parameter is to determine the interaction time between the plectrum and the string.

The *Edge* parameter is used to determine the sharpness of the edge of the pick. It is used to fine-tune the profiles of the three different plectrum models which affects the shape of the force signal exerted by the plectrum on the string and therefore the tone of the resulting sound. Turning this knob clockwise results in a rounder edge and a softer sound while turning it clockwise makes it sharper with more high frequencies in the tone. Finally, the *Position* knob is used to control the position of the interaction point of the plectrum along the string. This is a parameter currently used by guitar players to change the tone of the sound. In its leftmost position, the pick is very close to the bridge resulting in a more metallic sound. Turning the knob clockwise moves the pick toward the fretboard resulting in a rounder sound.

6.5.3 The Hammer Module

The *Hammer* module is used to control hammer-on et pull-off effects as explained in section 6.2.3. In *Strum*, hammer-ons and pull-offs are triggered when legato playing on the keyboard is detected. The two parameters of this section are *Tone* and *Amp*. The *Tone* knob is used to set the harmonic content of the excitation produced by the finger moving on the string as explained above. Turning this knob to the left results in a smoother sound while turning it clockwise results in a sharper sound. The *Amp* parameter controls the amplitude of the excitation generated by hammer-ons and pull-offs.



6.5.4 The Mute Module

In *Strum*, strings are muted when using the muffled downstroke or upstroke strumming keys or, in auto-strum mode, when a note is released on the keyboard. This reproduces the muting effect obtained by guitarists by releasing the pressure on the notes held by the fretting hand. The pressure applied on a given string is controlled using the *Contact* knob. In its leftmost position, the contact is very light and one can slightly hear the sound of the open string. When this knob is in its rightmost position, the pressure between the finger and the string is strong and one can hear the pitch of the fretted note. In its middle position, the string is muted efficiently and one can, depending on the fret where the finger is located, hear harmonics ringing. The tone and decay time of these harmonics are set using the *Tone* and *Decay* knobs which fix the decay time and the spectral content of these tones respectively. When muting a string it takes a little time for the guitar player to release the pressure on the finger on the string in order to place them in muting position. This time is set using the *Time* knob and the release time is increased by turning the knob clockwise.



6.5.5 The Palm Module

In *Strum*, palm muting is achieved by using the palm muted downstroke and upstroke keys. The resulting sound of this effect can be adjusted with the help of the *Decay* and *Tone* parameter. The *Decay* knob is used to set the decay time of the sound when the strings are palm muted. In other words, it controls the amount of overall damping induced by the picking hand. Turning this knob clockwise increases the decay time. The *Tone* knob controls the amount of high frequencies in the resulting sound relatively to the amount of low frequencies or in other words the tone of the sound. Turning this knob clockwise increases the amount of high frequencies in the sound.



6.5.6 The Pickups Module

The **Pickups** module simulates the action of the pickups on the guitar. There are two pickups in *Strum*, labeled *Neck* and *Bridge*, which can be adjusted in various ways in order to obtain tonal colors of different guitar types. They are activated by using the *N*, *B* or *+* selector on the main view of the interface as explained in section 6.2.5.

The *Type* selector allows one to choose between single coil or humbucker pickups by clicking on the *S* or *H* button respectively. Single coil pickups are made, as their name suggest, from a single coil wounded around a permanent magnet. While this type of pickup sounds great it has the disadvantage on a real guitar that it transmits, in addition to the signal from the vibrating string, mains hum at the frequency of the mains alternating current. In order to overcome this effect a clever device, known as the humbucker pickup, was developed. Basically, a humbucker pickup consists of two single coil pickups with opposing windings and polarities wired in series. This arrangement results in a reduction of the ambient noise by destructive interference while the signal from the strings is amplified due to constructive interference. But noise reduction is not the only effect of using two coils. This configuration also changes the tone of the pickup which is responsible for the characteristic tone of specific guitar types. Humbucker pickups typically produce a “warm” and “fat” tone while single coil pickups usually sound “brighter” and “clearer”.



The electric signal from the pickup is sent to the amplifier via a simple electric circuit and a cable. The combined inductance, capacitance and resistances of this circuit form a resonant low-pass filter. The quality factor and the cut-off frequency of this circuit can be adjusted for each pickup using the *Freq* and *Res* knobs respectively allowing one to further adjust the tone of the guitar signal.

The position of each pickup can also be adjusted from bridge to neck position using the *Pos* knob. Using the *M* or mid position allows to position the pickup halfway between the bridge and the neck. It is common, in different guitar types to listen to a single pickup at each of these position or to mix the signal from the bridge and neck pickups or to combine one of these with the signal from a third one positioned in the middle. On a real guitar, one can choose between these different configurations using switch on the body of the instrument.

Finally, another parameter which affects the sound of the guitar is the relative amplitude of the signal from each pickup. On a real instrument this is controlled by adjusting the vertical distance between the pickups and the strings. In *Strum* this is adjusted using the *Trim* knob which allows one to vary the amplitude of the neck pickup from -10 dB (leftmost position) to 10 dB (rightmost position).

6.6 Performance Parameters

6.6.1 Chord Display

The *Chord Display* is where *Strum* displays the name of the detected chord or note and the corresponding voicing selected. Strings are labeled from lowest to highest as follows:

- String 6: E2 (MIDI note number 40)
- String 5: A2 (MIDI note number 45)
- String 4: D3 (MIDI note number 50)
- String 3: G3 (MIDI note number 55)
- String 2: B3 (MIDI note number 59)
- String 1: E4 (MIDI note number 64)

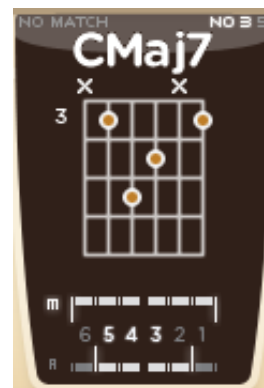

Notes played are identified by a circle on the corresponding string and the position on the fretboard is determined by the fret number appearing in the upper left corner of the display which corresponds to the number of the first fret in the display. Strings that are not played are marked with an 'X' at the top of the chord display. When a string is triggered, its number is highlighted at the bottom of the display while it vibrates. For a list of all the chords detected by *Strum*, please refer to section 12.

Additional information on the chord is available at the top of the display above the name of the chord itself. When the chord detected contains no third or no fifth the corresponding *no 3* or *no 5* message is highlighted. Finally, while *Strum* can recognize a great variety of chords and find most voicings used by guitar players, it is possible that it will not find a voicing in its chord database for a particular chord played on the keyboard. In these cases, the *no match* message is lit. *Strum* will still display the chord name and propose a guitar voicing constructed according to a certain set of rules. The chord should still sound right but the message is displayed in order to indicate that the voicing chosen by *Strum* is probably very difficult to play on the guitar and might therefore not be commonly used by guitar players.

6.6.2 Chord

On the guitar, chords can be voiced in many different ways. The specific voicing chosen by *Strum* for a chord depends on the *Type* parameter. One can choose between open, movable and drop chords as described in section 4.6. The voicing can also be made more precise by specifying what should be the lowest note of the chord played by *Strum*. In *root* position, the



lowest note of the guitar voicing is always the root of the chord played on the keyboard and detected by *Strum*. In *lowest* position, the lowest note of the voicing follows the lowest note played on the keyboard. It is also possible to tell *Strum* in which neck position to play chords using the *Playing Position* parameter. The position is specified in fret number and indicates the lowest fret on which the lowest note of the chord should be played. It is not always possible to satisfy this constraint and *Strum* will respect this position whenever it is possible. This parameter is of course only valid for movable chords and it is therefore inactive when open chords are chosen.

The last parameter in the *Chords* section is called *Time*. This parameter is used to control the delay between the moment a chord is played on the keyboard and the moment it is triggered by *Strum*. This parameter is necessary because when a chord is played on the keyboard, the notes are not necessarily played simultaneously. *Strum* must therefore wait a certain time before sending a group of notes to the chord detection module in order to make sure that it has received all the notes which are supposed to form the chord. This delay should not be smaller than the interval between the moment the first and last notes are played. Using a value too small for this parameter will result in individual notes of the chord being played before it is actually strummed. The value of this parameter should vary depending on the playing skill and style of the keyboard player and should be adjusted to a value allowing enough time for a chord to be played on the keyboard and be well detected by *Strum*.

6.6.3 Loop

The loop player is used to control *Strum* with MIDI loops. Loops can contain both chords and strumming key sequences. In this case, playing a loop is similar to playing a tune. Loops can also only contain strumming sequences and the loop player is then used to play rhythmic or strumming patterns over chords currently played on the keyboard. Using loops is useful to carefully control or edit a performance or execute passages that are difficult to play on the keyboard.

Loops are loaded using the *Load* button of the player. This will open a folder from which loops can be selected. If a loop was already loaded in the player, the *Load* button will open the folder where this loop is located. If the player is empty, this button will open a default loop folder which can be specified in the **Preferences** dialog from the **Edit** menu of the application. Loops can also be loaded by clicking on them and drag-and-dropping them onto the MIDI loop player.

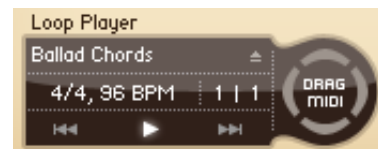

Once a loop is loaded, its name is displayed in the top part of the loop player. Information on the tempo and time signature of the loop is displayed just below its name. The loop is started by clicking on the *Play* button located in the lower part of the player. Once a loop has been started, it can be stopped by clicking on the *Pause* button and then restarted again by clicking on the *Play* button. While a loop is being played, indication on the current position within the loop is displayed on the right of the middle section of the player. The position is indicated, from left to right, as the current bar number and current beat within this bar. When a loop is loaded in the player, it is

possible to scan the loops in the same folder using the *skip forward* and *skip backward* buttons. The loops are scanned in alphabetical order starting from the currently loaded loop.

Once a loop has been selected, it might be necessary to modify it. A loop can rapidly be exported to the MIDI track of a sequencer by using the *Drag MIDI* button. To export the loop, click on the *Drag MIDI* button, then drag-and-drop the file onto a MIDI track of a sequencer.

Strum is supplied with a library of MIDI loops which you can use to easily start creating a new piece. The factory setting for the default MIDI loop folder is the folder where the library was first copied when *Strum* was installed.

6.6.4 Strumming

The *Strumming* section includes parameters which are used to determine how the strumming is performed. The *Speed* parameter controls how rapidly the different strings are played when a strum is triggered. The speed of the strum is increased by turning the knob clockwise. This parameter can be modulated by the keyboard velocity using the *Velocity* knob. When in its center position, the speed is always that corresponding to the value of the *Speed* knob. Turning the velocity knob clockwise increases the strumming speed for high keyboard velocities while it reduces the speed for low keyboard velocities. Turning this knob below its middle position has the opposite effect; playing softly on the keyboard will increase the strumming speed while playing hard will reduce the speed.

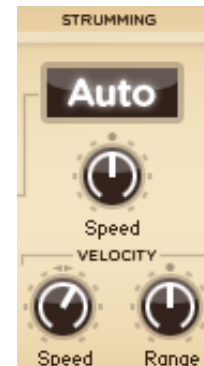

The *Auto* button is used to switch *on* or *off* the *Auto-Strum* mode. When this mode is *on*, notes and chords will be played by *Strum* as they are played on the keyboard. When *Auto-Strum* mode is *off*, chords are recognized and voiced by *Strum* but the strings are not triggered until strumming keys are used. For more details on how to use the strumming keys, please refer to section 3.2. Note that, as was mentioned in section 6.6.2, when the *Auto-Strum* mode is *on*, *Strum* introduces a delay between the time notes are played on the keyboard and the time a chord is actually triggered. This delay is adjusted using the *Time* knob from the *Chord* section and is necessary in order to take into account that notes in a chord are not necessarily played perfectly simultaneously.

The *Chord Range* selector located below the chord display is used to determine the range of strings which will be played when a main or alternate strum is triggered. As was discussed in section 4.4.4, it is indeed possible to define two strum ranges which can be used alternatively in order to vary the tone color of the chords played. The main range is always used by *Strum* except if the *alternate strum* strumming key (B4) is depressed while another strumming key is used or if the hold pedal (with alt strumming position selected) is activated.

The range of the main and alternate strums can be adjusted by using the *Main* and *Alt* controls located below the chord display. For each range the lowest and highest strings played when triggering a chord are specified by click-dragging the cursors located at each extremities of the display. Note that the range must contain at least one string.

The *Range* parameter under *velocity* in the *Strumming* section allows one to modulate the number of strings played with the MIDI velocity signal received by the program. This is used to emulate the fact that the number of strings in a chord played by a guitarist may vary depending on the intensity of the playing. When in its middle position and playing mezzo forte on the keyboard, the lowest and highest strings in the chord will be excluded from the strumming. As the MIDI velocity is reduced more and more strings are excluded while more are added as the velocity is increased. In other words, the higher the velocity, the greater are the chances that all the strings in the chord will be played. Moving the knob clockwise from its middle position makes it harder to play the strings at the extremities therefore requiring a higher velocity. Turning the knob anti-clockwise has the opposite effect and makes it easier and easier. In its leftmost position all the strings included in the strumming range, as indicated by the *Chord Range* selector, are always played whatever the value of the MIDI velocity.

6.6.5 Tuning

The *Tuning* module is used to transpose the output pitch of *Strum*. The output pitch can be increased or decreased by one semi-tone by moving the *tuning* knob clockwise or anti-clockwise respectively. When in its center position, *Strum* uses standard tuning (A4 - 440 Hz).

The output can also be transposed by one octave by switching *on* the *Octave* button. This is useful for reaching notes on the fretboard above C5 (MIDI note number 72) where the special strumming keyswitches are located.



6.6.6 Pitch Wheel

The keyboard pitch wheel is used to perform bends or slides. A bend is an increase of pitch obtained by pressing a string down on a fret and pushing the string up or down after triggering the string with the fretting hand. It is usually limited to one or two semi-tones. A slide is another technique used by guitar players to change the pitch of a note. It is obtained by pressing a string down with a finger, triggering the string with the fretting hand, and then moving the fretting finger up or down along the axis of the neck of the guitar across a certain number of frets.

To choose between a bend or slide effect, click on the corresponding button of the pitch wheel section. The range of the effect is selected from the *Range* drop-down menu. Note that a bend will be applied on the last note played in a chord while a slide will be applied to all the notes forming the chord.

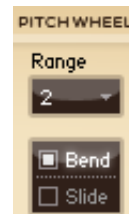

6.6.7 Aftertouch

In addition to the pitch wheel, monophonic aftertouch (channel pressure) can be used to control a bending effect. The depth of the effect is controlled using the *Depth* knob from the *Aft. Touch* section. In its center position, the depth is equal to 1 semi-tone.



6.6.8 Hold Pedal

The hold pedal MIDI controller can have two functions in *Strum*. When the *Hold Chord* button is switched *on*, *Strum* will hold the notes of a chord after the keys on the keyboard have been released as long as the pedal is depressed or until another chord is played. When the *Alt. Strum* button is switched *on*, the pedal can be used to switch between the main and alternate Strum as described in section 4.4.4.



6.6.9 The Velocity Section

The velocity section allows one to control the modulation of certain parameters with the MIDI velocity received by the application. The *Pick/Fingers* parameter is used to adjust the amount of modulation of all the parameters in the **Pick/Finger** module which are modulated by the velocity at once: *jut*, *stiffness* and *damping*. This control is in fact an *offset* knob and it is used to vary the settings these parameters knobs around their value specified in the **Pick/Finger** module. The *Palm Mute* parameter is used to modulate the value of the *Tone* parameter in the **Palm** module with the velocity. When the knob is in its leftmost position, there is no modulation from the MIDI note velocity signal; turning this knob clockwise gradually increases the amount of modulation.



6.6.10 Mod Wheel

The modulation wheel is used to control vibrato. The speed and depth of the vibrato is controlled by the *Speed* and *Depth* parameters respectively.



7 Utility Section

The utility section is located at the top of the *Strum Electric* interface and it includes important Strum parameters and monitoring tools.



7.1 The MIDI LED

The MIDI LED blinks when the synthesizer receives MIDI signal. If the application is not receiving MIDI signal, make sure that the right MIDI device is selected using the **MIDI Settings** command from the **MIDI** menu.

7.2 MIDI channel

The *Channel* drop-down menu allows one to choose which MIDI channel the application will listen to. When *omni* is selected, the application will listen to all channels. Otherwise, the application will listen to the specific channel selected. If you are not using *omni* mode, make sure that the MIDI channel selected corresponds to the same one as that used by your MIDI controller.

7.3 Compare

The *Compare* button is used to switch between edit and compare mode. The compare mode is useful when modifying presets, it allows one to revert to the original version of a preset once it has been modified and to compare the new version with the original one. When in *Compare* mode, edition is blocked and it is therefore not possible to modify any parameter. The *Compare* mode must then be switched off by clicking on the *Compare* button in order to resume edition.

7.4 Reverb

Strum Electric is equipped with a simple reverb which can be used to add ambiance to your sound. The *Reverb* knob is used to set the amount of wet signal in the mix, turning the knob clockwise increasing the amount of reverberation in the signal.

7.5 Volume

The *Volume* knob is the master volume of the application. It is used to adjust the overall level of the output signal from the application. General level is increased by turning the knob clockwise.

7.6 Level Meter

The level meter allows one to monitor the RMS (root means square) level of the left (L) and right (R) output channels from the synthesizer. As soft clipping is applied to the output signal in order to limit its amplitude, it is important to make sure that the amplitude of the signal remains within values that ensure that no distortion is introduced in the signal at the output.

The 0 dB mark on the level meter has been adjusted to correspond to -20 dBFS (full scale). This means that at that level, the signal is -20 dB below the maximum allowed value. This 0 dB level mark should typically correspond to playing at mezzo forte (moderately loud) level. This ensures a headroom of 20 dB which should be more than enough to cover the dynamics of most playing situations and therefore guarantee that that no additional distortion is added in the output signal.

Distortion is introduced by the output when the signal enters the red section of level meter which starts 3 dB below the clipping value. A peak value mark allows to follow the maximum level values reached by the output signal and therefore determine if clipping as occurred or not.

8 Toolbar

The toolbar at the top of the *Strum Electric* interface window allows you to monitor important information related to your current set-up.



8.1 Program Display

Located on the left of the toolbar, displays the number and name of the program currently loaded in the synthesis engine. The + and – buttons on the left of the program number, or alternatively the + and – keys on the computer keyboard, are used to navigate upwards and downwards in the program list. The complete list of 128 programs can be viewed by using the ▼ button located on the left of the program number. When the preset associated with the current program is different from the version saved in the preset library, the preset icon to the left of the buttons changes color in order to indicate that saving is necessary in order not to lose the changes that have been applied.

8.2 MIDI map

In the center of the toolbar, displays the name of the currently opened MIDI map. For more information on MIDI maps, please refer to Section 9.2.

8.3 CPU meter

On the right of the toolbar, displays the percentage of the total CPU resources currently used by *Strum Electric*.

8.4 Value Display

Just before the CPU meter, displays the value of the currently selected control on the interface. The values range from 0 to 127 for knobs and 0 or 1 for buttons depending on whether they are in their *on* or *off* position. For some controls, the value is displayed in the appropriate units.

9 Audio and MIDI Settings

This chapter explains how to select the audio and MIDI devices used by *Strum Electric* as well as how to create and edit MIDI links and MIDI maps. When referring to commands that are different on Windows and Mac OS systems, the commands are listed in the following order: Windows command/Mac OS command.

9.1 Audio Settings

9.1.1 Selecting an Audio Device

To select the audio device used by *Strum Electric*:

- Go to the **Audio** menu and choose the **Audio Settings** options. A list of the audio devices installed on your computer will appear in the **Audio Configuration** window.
- Click on the audio device you wish to use and click on the **OK** button.

9.1.2 Audio Control Panel

To launch the audio configuration panel, choose **Audio Control Panel** under the **Audio** menu. This command allows you to select the bit depth sample rate (22.05, 44.1, 48, or 96 kHz) and buffer size, which affects how quickly *Strum Electric* responds to the control information it receives. The smaller the buffer size, the shorter the latency, and vice versa.

On Windows systems using ASIO drivers, this command opens the control panel provided with the driver and the content of the dialog depends on the driver. Some sound cards also require that you close all programs before making changes to the buffer size or sampling rate. If you discover this is the case with your sound card, please refer to the manufacturer's documentation for details on configuring it for optimum performance. Most sound card manufacturers also update their drivers regularly. It is strongly recommended that you visit your sound card manufacturer's website regularly to ensure you are using the most up to date drivers and support software.

On Mac OS systems, this command launches the **Audio MIDI Setup** configuration application.

9.2 MIDI Settings

9.2.1 Selecting a MIDI Device

To select the MIDI device used by *Strum Electric*:

- Go to the **MIDI** menu and choose the **MIDI Settings** option. A list of the MIDI devices installed on your computer will appear in the **MIDI Configuration** window.
- Select the MIDI device you want to use and click on the **OK** button.

9.2.2 Creating MIDI Links

Every control on the *Strum Electric* interface can be manipulated by an external MIDI controller. In most cases this is much more convenient than using the mouse, especially if you want to move many controllers at once. For example, you can map the motion of a knob on the interface to a real knob on a knob box or to the modulation wheel from your keyboard. As you use the specified MIDI controllers, you will see the controls move on the *Strum Electric* interface just as if you had used the mouse.

To assign a MIDI link to a controller:

- On the interface, right-click/Control-click on a control (knob, button), a contextual menu appears. Select **Learn MIDI Link**.
- Move a knob or slider on your MIDI controller (this can be a keyboard, a knob box, or any device that sends MIDI). This will link the control of the *Strum Electric* to the MIDI controller you just moved.

MIDI links can also be created by right-clicking/Control-clicking on a control and choosing the **Add MIDI Link** command which will open the **Add MIDI Link** window.

9.2.3 Editing MIDI Links

MIDI links can be edited in the MIDI Links window, which lists all the currently available MIDI links.

- To edit the MIDI link, right-click/Control-click again on the control and choose **Edit MIDI Link** to open the MIDI links window. You can also use the **Edit MIDI Link** command from the **MIDI** menu.
- Click on the MIDI link you wish to modify and then on the **Edit** button to launch the **EDIT MIDI Link** window.
- Specify the MIDI controller number and MIDI channel of the physical controller you wish to link to the parameter in the corresponding drop-down menus.
- You can also adjust the **Minimum Value** and **Maximum Value** of the controller, which are used to limit the range of MIDI controllers. The **Minimum Value** slider is used to determine the position on the *Strum Electric* control which corresponds to the minimum value sent by the MIDI controller; the **Maximum Value** slider determines the position which corresponds to the maximum value sent by the MIDI controller. The leftmost position of the slider corresponds to the *Strum Electric* control minimum position (left position for a knob) while the rightmost position of the slider corresponds to the *Strum Electric* control maximum position (right position for a knob).

- Note that the range of a knob can be inverted by setting the value of **Maximum Value** to a smaller value than that of **Minimum Value**.
- Click on the **OK** button and the link appears in the list of controllers linked to the control.
- Click on the **OK** button again to confirm the change and to leave the MIDI Links window.
- Note that the **Minimum Value** and **Maximum Value** of a MIDI link can also be set by right/control clicking on the corresponding control and selecting the **Set MIDI Link Minimum Value** or **Set MIDI Link Maximum Value** command. The value corresponding to the control position will then be saved as the minimum or maximum value of the MIDI link.

9.2.4 Deleting MIDI Links

- To remove a MIDI link, right-click/Control-click again on the control and choose **Forget MIDI Link** or choose the **Forget MIDI Link** command from the **MIDI** menu.
- MIDI links can also be removed from the MIDI Links window by clicking on the MIDI link to be removed to select it, then by clicking on the **Remove** button and the **OK** button to confirm the change.

9.2.5 Creating a MIDI Map

A set of MIDI links can be saved into a MIDI map by using the **Save MIDI Link As** from the **File** menu. Different MIDI maps corresponding to different MIDI controllers can thereby be saved for *Strum Electric*. A MIDI map can be loaded by double clicking on the corresponding MIDI connector icon that appears in the browser when a MIDI map is saved. Furthermore a MIDI map can be loaded automatically when an instrument is launched.

- To assign a default MIDI map, right-click/Control-click on the MIDI map icon and choose the **MIDI Link Info** command. In the **Edit Information Window**, select the **Set as default MIDI Links** option.

9.2.6 Empty MIDI Map

The factory MIDI maps include a MIDI map called **No MIDI link**. As its name suggest this map is empty. Loading this map deactivates all the MIDI links.

It is possible to reload the original version of this MIDI map by importing the factory MIDI maps file as explained in Section 5.9 in case it was modified by mistake.

9.2.7 Defining a Default MIDI Map

It is possible to define a default MIDI map that will be loaded automatically when *Strum Electric* is launched.

- First select a MIDI map by clicking on its icon in the browser and choose the **MIDI Link Info** command from the **Edit** or the Ctrl-I/Apple-I keyboard shortcut. One can also right-click/control-click on the MIDI map icon and choose the **MIDI Link Info** command.
- To change the default MIDI map select the **Mark As Default** option.

9.2.8 MIDI Program Changes

MIDI program changes can be used to switch between programs while playing. *Strum Electric* will change the number of the current program used by the synthesis engine to the number corresponding to the MIDI program change received by the application.

9.3 Latency Settings

The latency is the time delay between the moment you send a control signal to your computer (for example when you hit a key on your MIDI keyboard) and the moment when you hear the effect. Roughly, the latency will be equal to the duration of the buffers used by the application and the sound card to play audio and MIDI. To calculate the total time required to play a buffer, just divide the number of samples per buffer by the sampling frequency. For example, 256 samples played at 48 kHz represent a time of 5.3 ms. Doubling the number of samples and keeping the sampling frequency constant will double this time while changing the sampling frequency to 96 kHz and keeping the buffer size constant will reduce the latency to 2.7 ms.

It is of course desirable to have as little latency as possible. *Strum Electric* however requires a certain amount of time to be able to calculate sound samples in a continuous manner. This time depends on the power of your computer, the preset played, the sampling rate, and the number of voices of polyphony used. Note that it will literally take twice as much CPU power to process audio at a sampling rate of 96 kHz as it would to process the same data at 48 kHz, simply because you need to calculate twice as many samples in the same amount of time.

Depending on your machine you should choose, for a given sampling frequency, the smallest buffer size that allows you to keep real-time for a reasonable number of voices of polyphony. To adjust these parameters:

- Launch the **Audio Control Panel**
- Choose the sampling frequency and the audio format (16, 24, 32 bits)
- Adjust the buffer size

Note that this might not be possible on Mac OS or with ASIO drivers on Windows.

10 Using *Strum Electric* as a Plug-In

Strum Electric is available in VST, AudioUnit and RTAS formats and integrates seamlessly into the industry most popular multi-track recording and sequencing environments as a virtual instrument plug-in. The plug-in versions will work exactly the same way as the standalone version, except for the audio, MIDI, and latency configurations that will be taken care of by the host sequencer. Furthermore *Strum Electric* works as any other plug-in in these environments so we recommend that you refer to your sequencer documentation in case you have problems running *Strum Electric* as a plug-in. We review here some general points to keep in mind when using a plug-in version of *Strum Electric*.

10.1 Window Size

The size of the *Strum Electric* window is fixed when it is used as a plug-in.

10.2 Audio and MIDI Parameters

When *Strum Electric* is used as a plug-in, the audio and MIDI ports, sampling rate, buffer size, and audio format are determined by the host sequencer.

10.3 Automation

Strum Electric supports automation functions of host sequencers. Automation can usually be done by using MIDI links and recording MIDI events, or by recording the motion of controls on the interface.

10.4 Multiple Instances

Multiple instances of *Strum Electric* can be launched simultaneously in a host sequencer.

10.5 Saving Projects

When saving a project in a host sequencer, the program list is saved with the project in order to make sure that the instrument will be in the same state as when you saved the project when you re-open it even if the preset library of the instrument was modified. MIDI links are also saved.

Note that the default program list (the same as that loaded in standalone mode) appears when *Strum Electric* is opened in a new project or if a new instance of the plug-in is opened in an existing project. To change the default program list, use the **Save All Programs** command from the **Programs** menu in an instance of the instrument which displays the desired program list.

10.6 MIDI Channel

Make sure that the MIDI controller, sequencer and *Strum Electric* all use the same MIDI channel. If you are not certain of the channel used by your controller or sequencer, set the MIDI channel of *Strum Electric* to *Omni*.

10.7 MIDI program change

MIDI program changes are supported in the plug-in versions of *Strum Electric*. When a MIDI program change is received by the application, the current program used by the synthesis engine is changed to that having the same number as that of the MIDI program change message.

10.8 Performance

Using a plug-in in a host sequencer requires CPU processing for both applications. The load on the CPU is even higher when multiple instances of a plug-in or numerous different plug-ins are used. To decrease CPU usage, remember that you can use the **freeze** or **bounce to track** functions of the host sequencer in order to render to audio the part played by a plug-in instead of recalculating it every time it is played.

11 Quick Reference to Commands and Shortcuts

File Menu

Command	Windows	Mac OS	Description
New Folder. . .		Apple+Shift+N	New Folder in the Browser
Open Preset	Ctrl+O	Apple+Option+O	Open the selected preset
Save Preset	Ctrl+S	Apple+S	Save the current preset
Save Preset As. . .			Save the current preset under a new name
Save MIDI Links	Ctrl+Shift+S	Apple+Shift+S	Save the current MIDI links
Save MIDI Links As. . .			Save the current MIDI links under a new name
Import. . .			Import a .strumA file
Export. . .			Export a .strumA file
Restore Factory Library . . .			Restore factory library and programs. Everything else in the browser is deleted.
Exit (Quit on Mac)			Quit the application

Edit Menu

Command	Windows	Mac OS	Description
Undo	Ctrl+Z	Apple+Z	Undo last command
Redo	Ctrl+Y	Apple+Shift+Z	Redo last command
Copy	Ctrl+C	Apple+C	Copy selected item
Paste	Ctrl+V	Apple+V	Paste
Delete	Del		Delete selected item
Info...	Ctrl-I	Apple+I	Edit information about a selected item (browser)
Preferences			Display the Edit General Preferences window

Audio

Command	Windows	Mac OS	Description
Audio Settings			Display the Audio Settings window
Audio Control Panel			Display the Latency Settings window if DirectSound is used, the ASIO control panel when ASIO drivers are used and the Audi MIDI setup configuration tool on Mac OS systems

MIDI

Command	Windows	Mac OS	Description
MIDI Settings			Display the MIDI Settings window
Learn MIDILink			MIDI link learn mode for the last control touched
Add MIDI Link			Enables one to add a MIDI link on the last controlled touched
Forget MIDILink			Drop a MIDI link
Set MIDI Link Minimum Value			Limit the value of a MIDI link to a minimum value
Set MIDI Link Maximum Value			Limit the value of a MIDI link to a maximum value
Edit MIDIlinks			Display the Edit MIDI links window
All Notes Off			Send an all note off signal

Programs Menu

Command	Windows	Mac OS	Description
Locate Program in Browser	Ctrl-L	Apple-L	Locate the current program in the browser and select it
Rename Program	Ctrl-R	Apple-R	Rename the current program in the program list
Switch to Program	Ctrl-P	Apple-P	Change the current program
Save All Programs			Save the entire program list including modifications to programs. The list will be in exactly the same state the next time you open the application

Help Menu

Command	Windows	Mac OS	Description
About Strum Electric GS ...			Display the About Strum Electric window
User Manual	F1		Display the user manual
Quick Reference Sheet			Display the keyboard layout reference sheet
Authorize Strum Electric ...			Display the Authorization window. Active only if the application has not been authorized.
Visit www.applied-acoustics.com ...			Launch the browser and go to the AAS website.
Join the user forum ...			Launch the browser and go to the AAS forum.
Get support ...			Launch the browser and go to the support section of the AAS website.

12 Appendix A - List of Chords Detected by *Strum*

We present here a list of the main chords recognized by *Strum* and for which it can find a guitar voicing. The following guidelines should be kept in mind:

- The chords are presented using C as the root. They can be transposed in any key.
- For all chords, inversions are recognized except if they conflict with another chord from this list.
- Inverted chords on the keyboard do not necessarily have a corresponding voicing on the guitar. In these cases *Strum* will still propose a voicing; it is not guaranteed that this voicing will be playable on the guitar and the *no match* sign will be lit in the chord display.
- When chords are played on the keyboard, the order of the notes above the root is not taken into account by *Strum*. This implies that you can play the chords as you know them on the keyboard without having to know or learn special voicings used by guitar players.
- Certain guitar voicings do not include all the notes played on the keyboard.
- In addition to the chords listed below, *Strum* can recognize other chords for which it has no guitar voicing. In these cases *Strum* will still propose a voicing; it is not guaranteed that this voicing will be playable on the guitar and the *no match* sign will be lit in the chord display.

List of Chords recognized and voiced by *Strum*

C	Cm	Csus2
Csus4	Caug	Cdim
C(b5)	C6	Cm6
Cm6 (no 5)	C7	C7 (no 3)
C7 (no 5)	Cm7	Cm7 (no 5)
C7sus2	C7sus2 (no 5)	C7sus4
C7sus4 (no 5)	C7#5	Cdim7
C7b5	Cm7b5	CMaj7
CMaj7 (no 3)	CMaj7 (no 5)	CmMaj7
CMaj7sus2	CMaj7sus4	CMaj7b5

List of Chords recognized and voiced by *Strum*

Cadd9	C9	C9 (no 5)
Cm9	Cm9 (no 5)	C9sus4
C9sus4 (no 5)	C9#5	C9b5
CMaj9	CMaj9 (no 5)	CmMaj9
CmMaj9 (no 5)	CMaj9b5	C6 9
Cm6 9	Cm6 9 (no 5)	Cm11
Cm11 (no 5)	C13	C13 (no 5)
Cm13	Cm13 (no 5)	C13b9
C13b9 (no 5)	CMaj13	CMaj13 (no 5)
C7b9	C7b9 (no 5)	C7#9
C7#9 (no 5)	C7b5b9	C7b5#9
C7#5b9	C7#5#9	C7#11
Cm7 11	Cm7 11 (no 5)	CMaj7#11
C7b9#11	C7#9#11	C7#9#11 (no 3)
C7 13	C7 13 (no 5)	Cm7 13
Cm7 13 (no 5)	C7b13	CMaj7 13
CMaj7 13 (no 5)	C7b9b13	C7#9b13
C9#11	CMaj9#11	C9b13

List of Chords - Example of a possible position on the keyboard.

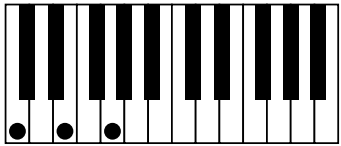

C

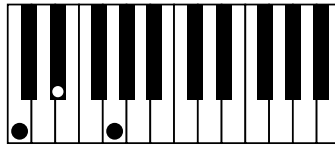

Cm

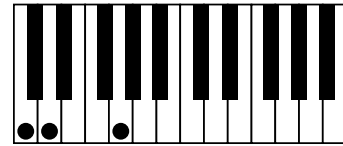

Csus2

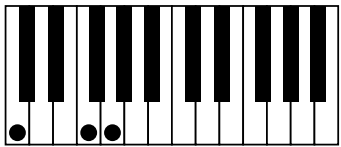

Csus4

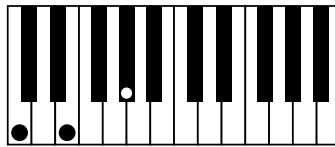

Caug

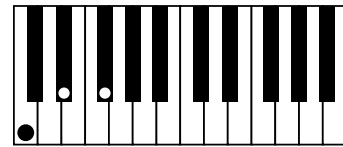

Cdim

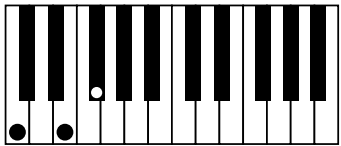

C(b5)

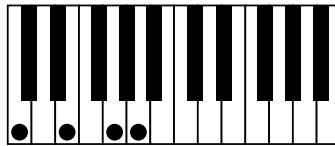

C6

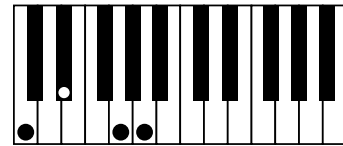

Cm6

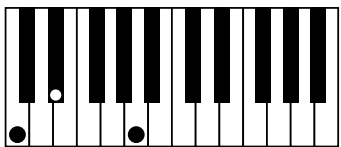

Cm6 (no 5)

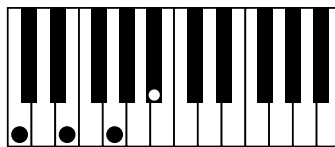

C7

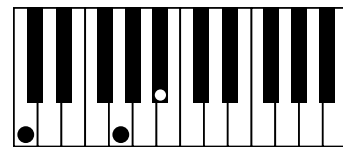

C7 (no 3)

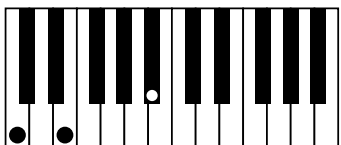

C7 (no 5)

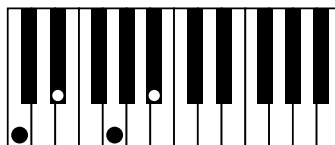

Cm7

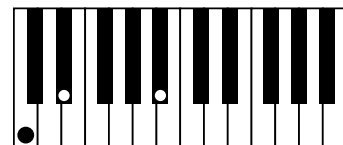

Cm7 (no 5)

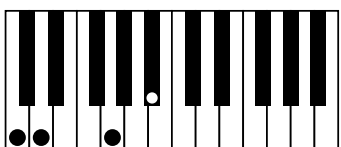

C7sus2

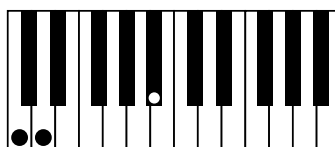

C7sus2 (no 5)

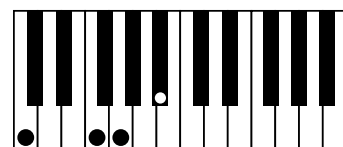

C7sus4

List of Chords - Example of a possible position on the keyboard.

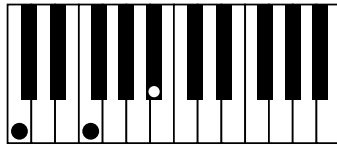

C7sus4 (no 5)

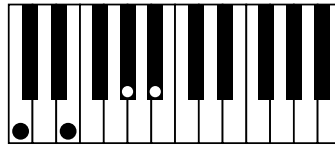

C7#5

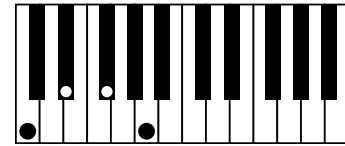

Cdim7

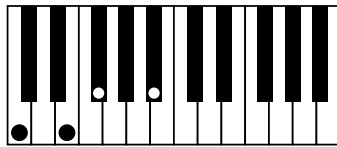

C7b5

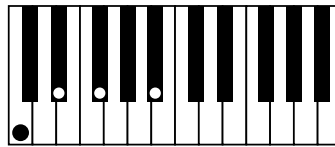

Cm7b5

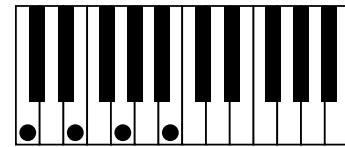

CMaj7

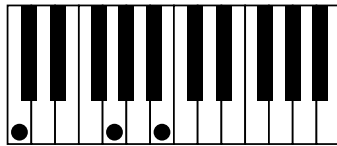

CMaj7 (no 3)

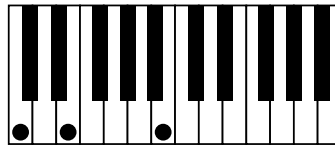

CMaj7 (no 5)

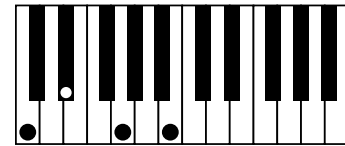

CmMaj7

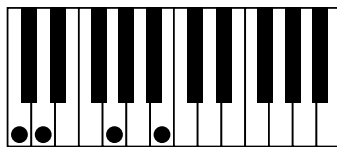

CMaj7sus2

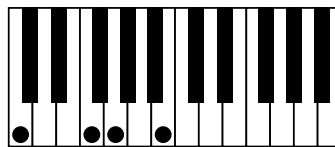

CMaj7sus4

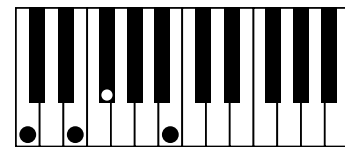

CMaj7b5

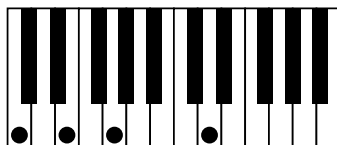

Cadd9

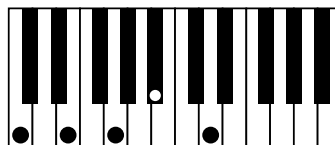

C9

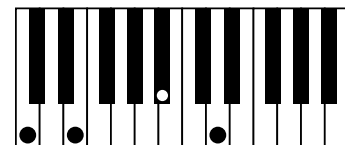

C9 (no 5)

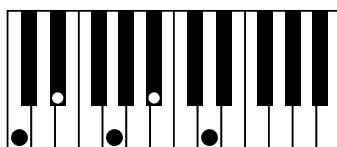

Cm9

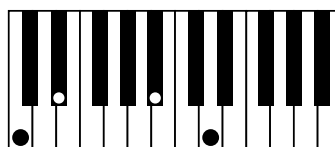

Cm9 (no 5)

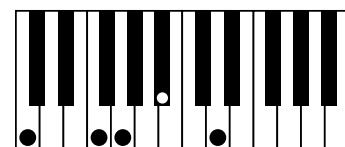

C9sus4

List of Chords - Example of a possible position on the keyboard.

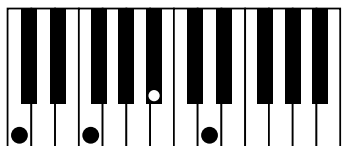

C9sus4 (no 5)

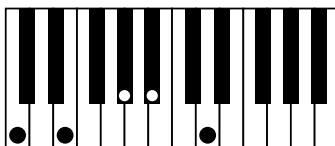

C9#5

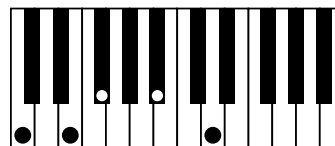

C9b5

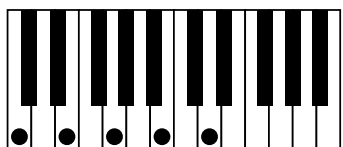

CMaj9

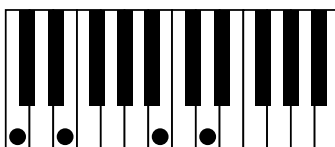

CMaj9 (no 5)

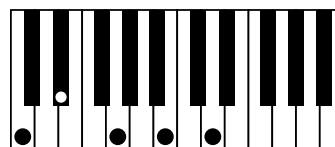

CmMaj9

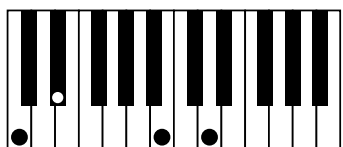

CmMaj9 (no 5)

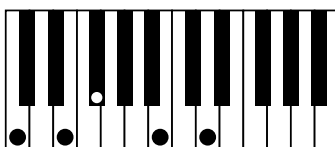

CMaj9b5

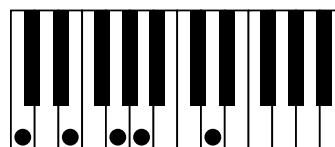

C6 9

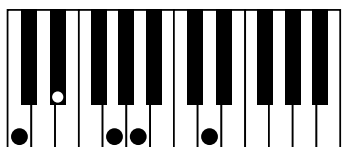

Cm6 9

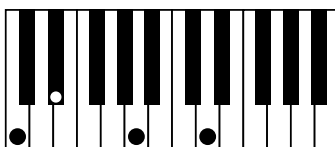

Cm6 9 (no 5)

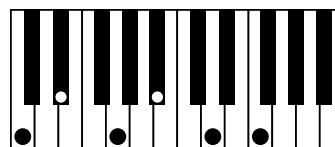

Cm11

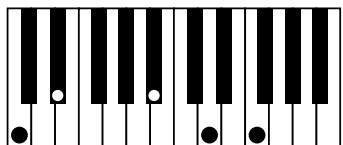

Cm11 (no 5)

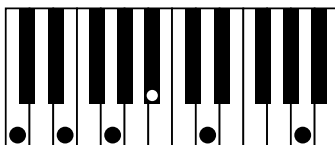

C13

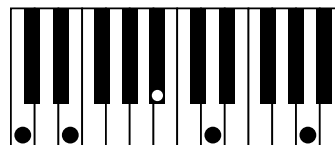

C13 (no 5)

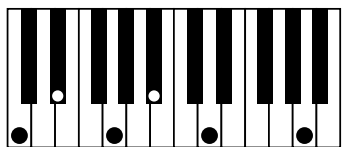

Cm13

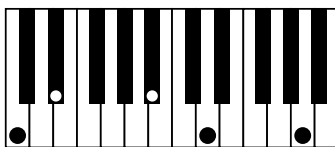

Cm13 (no 5)

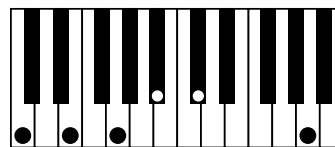

C13b9

List of Chords - Example of a possible position on the keyboard.

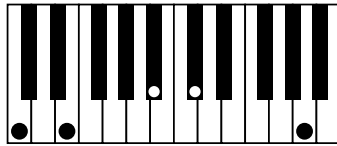

C13b9 (no 5)

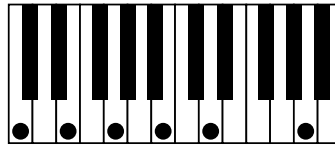

CMaj13

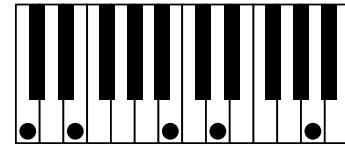

CMaj13 (no 5)

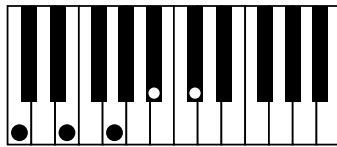

C7b9

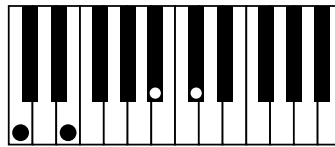

C7b9 (no 5)

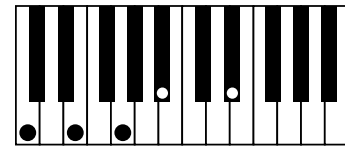

C7#9

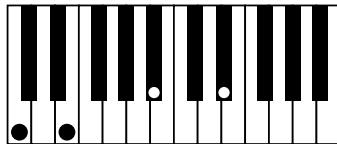

C7#9 (no 5)

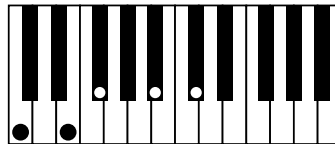

C7b5b9

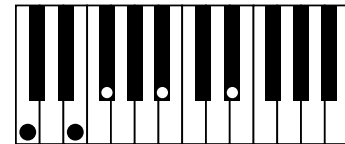

C7b5#9

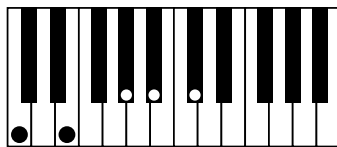

C7#5b9

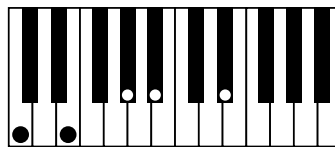

C7#5#9

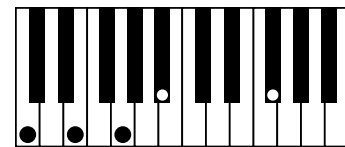

C7#11

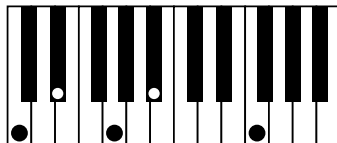

Cm7 11

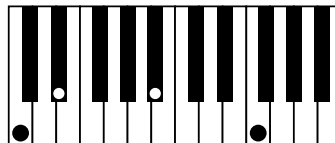

Cm7 11 (no 5)

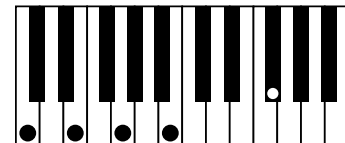

CMaj7#11

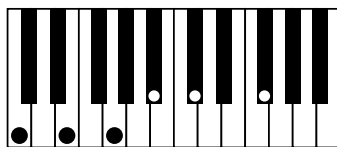

C7b9#11

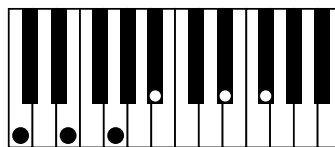

C7#9#11

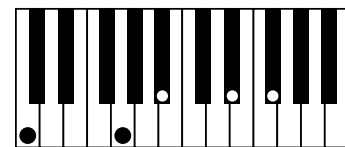

C7#9#11 (no 3)

List of Chords - Example of a possible position on the keyboard.

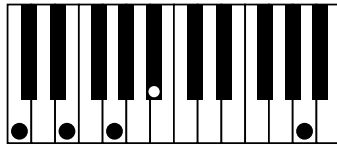

C7 13

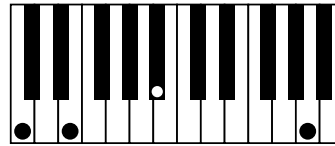

C7 13 (no 5)

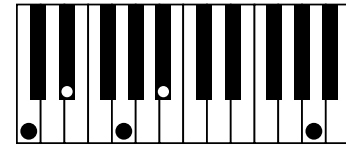

Cm7 13

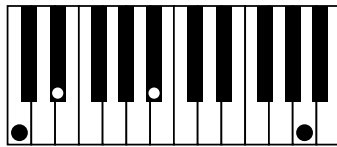

Cm7 13 (no 5)

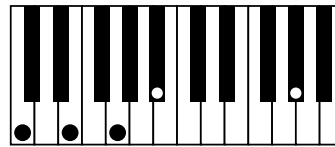
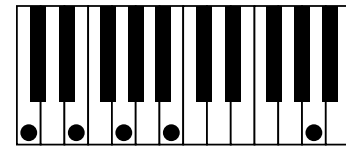
C7^b13

CMaj7 13

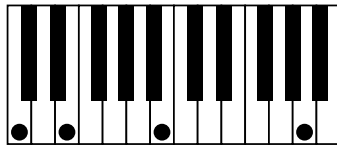

CMaj7 13 (no 5)

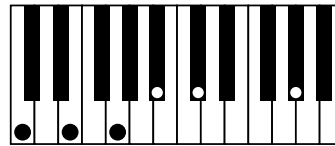
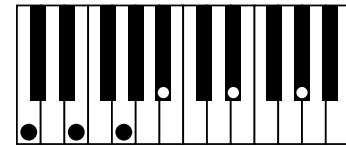
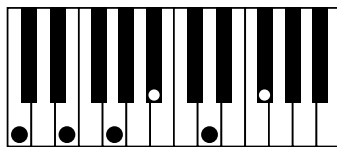
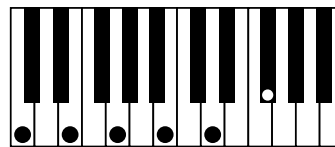
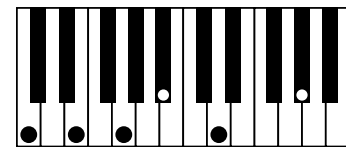
C7^b9^b13C7[#]9^b13C9[#]11CMaj9[#]11C9^b13

13 Appendix B - Parameter Override Keyswitches

We present here a list of keyswitches which can be used in a MIDI loop in order to temporarily override the value of certain parameters from the playing style section of the interface and ensure that a MIDI loop is always played exactly as intended by its creator. These special keyswitches correspond to the first MIDI notes which are below the playing range of the guitar.

13.1 Chord Section

These overrides keys are used to specify the chord type which should be used.

- 0(C-1): *Movable Lowest*
- 1(C#-1): *Open Lowest*
- 2(D-1): *Drop*
- 3(D#-1): *Reserved*
- 4(E-1): *Playing Position*

The keyswitch *Playing Position* has a special behavior. When this keyswitch is used, the MIDI velocity of the note is used to determine the playing position as follows:

- 1-9: *Not Used*
- 10-19: *1st Fret*
- 20-29: *2nd Fret*
- 30-39: *3rd Fret*
- 40-49: *4th Fret*
- 50-59: *5th Fret*
- 60-69: *6th Fret*
- 70-79: *7th Fret*
- 80-89: *8th Fret*
- 90-127: *Not Used*

13.2 Strumming Section

These overrides keys are used to adjust the strumming speed.

- 5(F-1): *Very Slow Strum - Value of 20%*

- 6(F#-1): Slow Strum - 40% if Strum Speed < 40%, 50% if Strum Speed > 50%
- 7(G-1): Minimum 50% - Value of Strum Speed if > 50%, otherwise 50%
- 8(G#-1): Minimum 65% - Value of Strum Speed if > 65%, otherwise 65%
- 9(A-1): Minimum 80% - Value of Strum Speed if > 80%, otherwise 80%

The following keyswitches are used to adjust the strumming range.

- 10(A#-1): Full Strum (string 1-6), Low Alt Strum (string 4-6)
- 11(B-1): Full Strum (string 1-6), Middle Alt Strum (string 2-5)
- 12(C0): Full Strum (string 1-6), High Alt Strum (string 1-3)
- 13(C#0): No Velocity Modulation on *Strum Range*
- 14(D0): Medium Velocity Modulation on *Strum Range*

13.3 Pitch Wheel Section

These overrides keys are used to adjust the behavior of the pitch wheel.

- 15: (D#0): 2 semitone bend
- 16: (E0): 1 octave bend
- 17: (F0): 2 semitone slide
- 18: (F#0): 1 octave slide

13.4 Aftertouch Section

This override key is used to adjust the behavior of the aftertouch.

- 19(G0): 2 semitone bend

13.5 Vibrato Section

These overrides keys are used to adjust the behavior of the vibrato.

- 20(G#0): Slow Vibrato - *Speed* = 3.5 Hz, *Depth* = 50%
- 21(A0): Medium Vibrato - *Speed* = 4.6 Hz, *Depth* = 50%
- 22(A#0): Quick Vibrato - *Speed* = 6.0 Hz, *Depth* = 50%

13.6 Velocity Section

This override key is used to adjust velocity modulation on the palm mute.

- 23(B0): Palm Mute Velocity - Value of 30%

14 License Agreement

IMPORTANT! CAREFULLY READ ALL THE TERMS AND CONDITIONS OF THIS AGREEMENT BEFORE OPENING THIS PACKAGE. OPENING THIS PACKAGE INDICATES YOUR ACCEPTANCE OF THESE TERMS AND CONDITIONS. IF YOU DO NOT AGREE WITH THE TERMS AND CONDITIONS OF THIS AGREEMENT, PROMPTLY RETURN THE UNOPENED PACKAGE AND ALL COMPONENTS THERETO TO THE PARTY FROM WHOM IT WAS ACQUIRED, FOR A FULL REFUND OF ANY CONSIDERATION PAID.

This software program, any printed materials, any on-line or electronic documentation, and any and all copies of such software program and materials (the “**Software**”) are the copyrighted work of Applied Acoustics Systems DVM Inc. (“**AAS**”), its subsidiaries, licensors and/or its suppliers.

1. **LICENSE TO USE.** The Licensee is granted a personal, non-exclusive and non-transferable license to install and to use one copy of the Software on a single computer solely for the personal use of the Licensee. Use of the Software is subject to this Agreement.
2. **RESTRICTIONS ON USE.** The Licensee may not nor permit third parties to (i) make copies of any portion of the Software, other than as expressly permitted under this Agreement; (ii) modify, translate, disassemble, decompile, reverse engineer or create derivative and/or competitive products based on any portion of the Software; (iii) provide use of the Software in a network, timesharing, interactive cable television, multiple CPU service bureau or multiple user arrangement to users not individually licensed by AAS, other than as expressly permitted by the terms of this license. The Software is licensed to you as a single product. Its component parts may not be separated for use on more than one computer.
3. **OWNERSHIP.** AAS retains title to the Software, including but not limited to any titles, computer code, themes, objects dialog concepts, artwork, animations, sounds, audio effects, methods of operation, moral rights, any related documentation and “applets” incorporated into the Software. AAS retains ownership of and title to all intellectual property rights in the Software, underlying technology, related written materials, logos, names and other support materials furnished either with the Software or as a result of this Agreement, including but not limited to trade secrets, patents, trademarks and copyrights therein. Licensee shall not remove or alter any copyright or other proprietary rights notices contained on or within the Software and shall reproduce such notices on all copies thereof permitted under this Agreement or associated documentation.
4. **LIMITED WARRANTY.** Except for the foregoing, THE SOFTWARE IS provided “AS IS” without warranty or condition of any kind. AAS disclaims all warranties or conditions, written or oral, statutory, express or implied, including but not limited to the implied warranties of merchantable quality or fitness for a particular purpose, title and non-infringement of rights of any other person. AAS does not warrant that THE SOFTWARE will meet the Licensee’s requirements or that the operation of the software will be uninterrupted or ERROR-FREE.

5. **LIMITATION OF LIABILITY.** TO THE MAXIMUM EXTENT PERMITTED BY APPLICABLE LAW, IN NO EVENT WILL AAS BE LIABLE TO THE LICENSEE OR ANY THIRD PARTY FOR ANY INDIRECT, SPECIAL, CONSEQUENTIAL, INCIDENTAL OR EXEMPLARY DAMAGES WHATSOEVER, INCLUDING BUT NOT LIMITED TO LOSS OF REVENUE OR PROFIT, LOST OR DAMAGED DATA, BUSINESS INTERRUPTION OR ANY OTHER PECUNIARY LOSS WHETHER BASED IN CONTRACT, TORT OR OTHER CAUSE OF ACTION, EVEN IF AAS HAS BEEN ADVISED OF THE POSSIBILITY OF SUCH DAMAGES, EXCEPT IN RELATION TO GROSS NEGLIGENCE OR WILFUL BREACH OF THIS AGREEMENT BY AAS. NO AAS AGENT, REPRESENTATIVE OR DEALER IS AUTHORIZED TO EXTEND, MODIFY OR ADD TO THIS WARRANTY ON BEHALF OF AAS. THE TOTAL LIABILITY OF AAS FOR DAMAGES, WHETHER IN CONTRACT OR TORT, UNDER OR RELATED IN ANY WAY TO THIS AGREEMENT SHALL BE LIMITED TO THE LICENSE FEES ACTUALLY PAID BY LICENSEE TO AAS, OR IF NO FEES WERE PAID, AAS' LIST PRICE FOR THE SOFTWARE COVERED BY THIS LICENSE. THE EXCLUSION OF IMPLIED WARRANTIES AND/OR THE LIMITATION OF LIABILITY IS NOT PERMITTED IN SOME JURISDICTIONS, AND SOME OR ALL OF THESE EXCLUSIONS MAY THEREFORE NOT APPLY.
6. **TERMINATION.** This License also shall extend to the Software and any updates or new releases thereof obtained by the Licensee, if any, subject to any changes to this License made by AAS from time to time and provided to the Licensee, provided AAS is under a separate obligation to provide to Licensee such updates or upgrades and Licensee continues to have a valid license which is in effect at the time of receipt of each such update or new release. This License shall remain in effect until terminated. The Licensee may terminate this Agreement at any time, upon notification to AAS. This Agreement will terminate immediately without notice from AAS if the Licensee fails to comply with any provision of this License. Any such termination by AAS shall be in addition to and without prejudice to such rights and remedies as may be available, including injunction and other equitable remedies. Upon receipt of notice of termination from AAS, the Licensee must (a) immediately cease to use the Software; (b) destroy all copies of the Software, as well as copies of all documentation, specifications and magnetic media relating thereto in Licensee's possession or control; and (c) return all original versions of the Software and associated documentation. The provisions of Sections 1, 3, and 5 shall survive the termination of this Agreement.
7. **GOVERNING LAW.** This Agreement shall be governed by and construed in accordance with the laws of the Province of Quebec, without regard to the United Nations Convention On Contracts for the International Sale of Goods and conflict of laws provisions, if applicable, and the parties hereby irrevocably attorn to the jurisdiction of the courts of that province. Les parties sont d'accord à ce que cette convention soit rédigée en langue anglaise. The parties have agreed that this agreement be drafted in the English language.
8. **SEVERABILITY.** If any of the above provisions are held to be illegal, invalid or unenforceable, such provision shall be severed from this Agreement and this Agreement shall not be

rendered inoperative but the remaining provisions shall continue in full force and effect.

9. ENTIRE AGREEMENT. This Agreement is the entire agreement between AAS and the Licensee relating to the Software and: (i) supersedes all prior or contemporaneous oral or written communications, proposals and representations with respect to its subject matter; and (ii) prevails over any conflicting or additional terms of any quote, order, acknowledgement, or similar communication between the parties during the term of this Agreement except as otherwise expressly agreed by the parties. No modification to the Agreement will be binding, unless in writing and signed by a duly authorized representative of each party.
10. NON-WAIVER. No delay or failure to take any action or exercise any rights under this Agreement shall constitute a waiver or consent unless expressly waived or consented to in writing by a duly authorized representative of AAS. A waiver of any event does not apply to any other event, even if in relation to the same subject-matter.

Index

- aftertouch, 26, 66
- alternate strum, 24, 66
- amplifier, 52
- apply offset, 48
- arp keys, 24, 28
- arpeggios, 24, 31
- ASIO drivers, 70
- audio, 70
 - configuration, 16, 70
 - device, 70
 - format, 70
- auto wah, 54
- auto-strum, 20, 28, 64
- auto-wah, 53

- bass and chords, 34
- bend, 25, 26
- browser, 16, 39
 - customizing, 45
 - hide, 44
 - resize, 44
- buffer size, 70, 73
- buttons
 - tweaking, 47
- cabinet, 52
- challenge key, 10, 11
- chords
 - change, 29
 - change of pitch, 29
 - detection, 19
 - detection time, 62
 - display, 62
 - drop, 37
 - list, 82
 - lowest, 37
 - movable, 37
 - open, 37
 - root, 37
 - type, 62
 - voicing, 37
- chorus, 53
 - mono, 53
 - stereo, 53
- clipping, 68
- commands, 76
- community, 18
- compare, 42, 67
- contact, 17

- database
 - backup, 45
 - restoring, 45
- default MIDI map, 73
- delay, 53
- digital delay, 53
- display, 48
- distortion, 52, 68
- documenting presets, 43
- downstroke, 23, 30
- driver, 70
- drop chords, 37

- edit, 42
- edit mode, 56
 - strings, 57
- edition of parameters, 56
- effect
 - notch filter, 55
 - wah wah, 54
- effects, 53
- export, 44

- factory presets, 16, 45
- fingers, 58
- flanger, 53, 54
 - mono, 54
 - stereo, 54
- folder
 - copying, 43

- creating, 42
- deleting, 43
- renaming, 43
- forum, 18
- general parameters, 48
- getting started, 15
- guitar level, 51
- hammer-on, 30, 50, 60
- help, 17
- hold pedal, 66
- import, 44
- individual strings, 24
- installation, 10
- knobs, 47
 - tweaking, 47
- latency, 70, 73
- level meter, 68
- loop player, 63
- MIDI, 70
 - device, 70
 - loop player, 63
 - receiving, 67
 - settings, 70
- MIDI channel, 67
- MIDI configuration, 16
- MIDI controller, 71
- MIDI LED, 67
- MIDI links, 17
 - creating, 71
 - deactivate, 72
 - editing, 71, 72
 - factory, 45
 - range, 71
- MIDI loops
 - creating, 36
 - override keyswitches, 36, 89
 - using, 35
- MIDI map, 44, 69, 72
 - default, 44, 73
 - documenting, 44
 - empty, 72
 - preset, 45
- MIDI program change, 17, 40, 73
- modulation, 48
 - strumming range, 64
 - strumming speed, 64
 - velocity, 66
- modulation wheel, 26, 66
- module
 - bypassing, 48
- modules, 47
- movable chords, 37
- muffled downstroke, 31
- muffled strokes, 24
- muffled upstroke, 31
- multi-effect
 - auto wah, 54
 - chorus, 53
 - delay, 53
 - flanger, 54
 - phaser, 54
 - tremolo, 56
- multi-effects, 53
- mute, 60
- mute all, 24
- muted strum, 33
- no 3, 62
- no 5, 62
- no match, 62
- notch filter, 53, 55
- octave, 65
- offset, 48
- open chords, 37
- override keyswitches, 36, 89
- overview, 19
- palm, 51, 60
- palm muted downstroke, 31
- palm muted upstroke, 31

- palm muting, 24
- parameters, 47, 48
- partial strumming, 33
- peak, 68
- performance, 9
- performance parameters, 62
- phaser, 53, 54
- pick, 58
- pick/fingers, 50, 58
- picking, 24
- pickups, 51, 61
 - bridge, 51, 61
 - cutoff, 61
 - humbucker, 61
 - neck, 51, 61
 - position, 51, 61
 - resonance, 61
 - single coil, 61
 - trim, 61
- ping pong delay, 53
- pitch bend, 25
- pitch wheel, 65
- plug-in, 17
 - audio parameters, 74
 - automation, 74
 - MIDI channel, 75
 - MIDI parameters, 74
 - MIDI program change, 75
 - multiple instances, 74
 - performance, 75
 - saving projects, 74
 - window size, 74
- polyphony, 10
- power chords, 35
- powerchords, 37
- preset, 16, 39, 69
 - backup, 45
 - browser, 39
 - changing, 40
 - compare, 42
 - copying, 43
 - database, 45
 - deleting, 43
 - documenting, 43
 - edit, 42
 - editing, 41
 - exporting, 44
 - factory, 45
 - importing, 44
 - library, 16, 39, 42
 - locating, 44
 - moving, 43
 - name, 69
 - playing, 40
 - program, 40
 - renaming, 43
 - saving, 41
- program, 40
 - saving, 42
- program list, 16
- pull-off, 30, 50, 60
- range, 64
- redo, 42
- registration, 10, 11
- response key, 11, 14
- reverb, 67
- sampling rate, 10, 70
- scratch, 31
- shortcuts, 76
- signal flow, 19, 20
- speaker, 52
- spring reverb, 52
- standalone mode, 15
- stationary bend, 34
- strings, 49, 57
- strum down, 28
- strum range, 64
- strumming, 20, 64
 - auto, 64
 - keys, 64
- strumming keys, 20, 23, 28, 30
- sustain, 66
- system requirements, 9

tape delay, 53
toolbar, 69
tremolo, 53, 56
tremolo picking, 33
trills, 33
tuning, 65

undo, 42
unlocking, 10
upstroke, 23, 30
user library, 18
utility section, 67

velocity, 66
vibrato, 26
voicing, 19
volume, 67
VU meter, 68

wah wah, 53, 54
website, 18