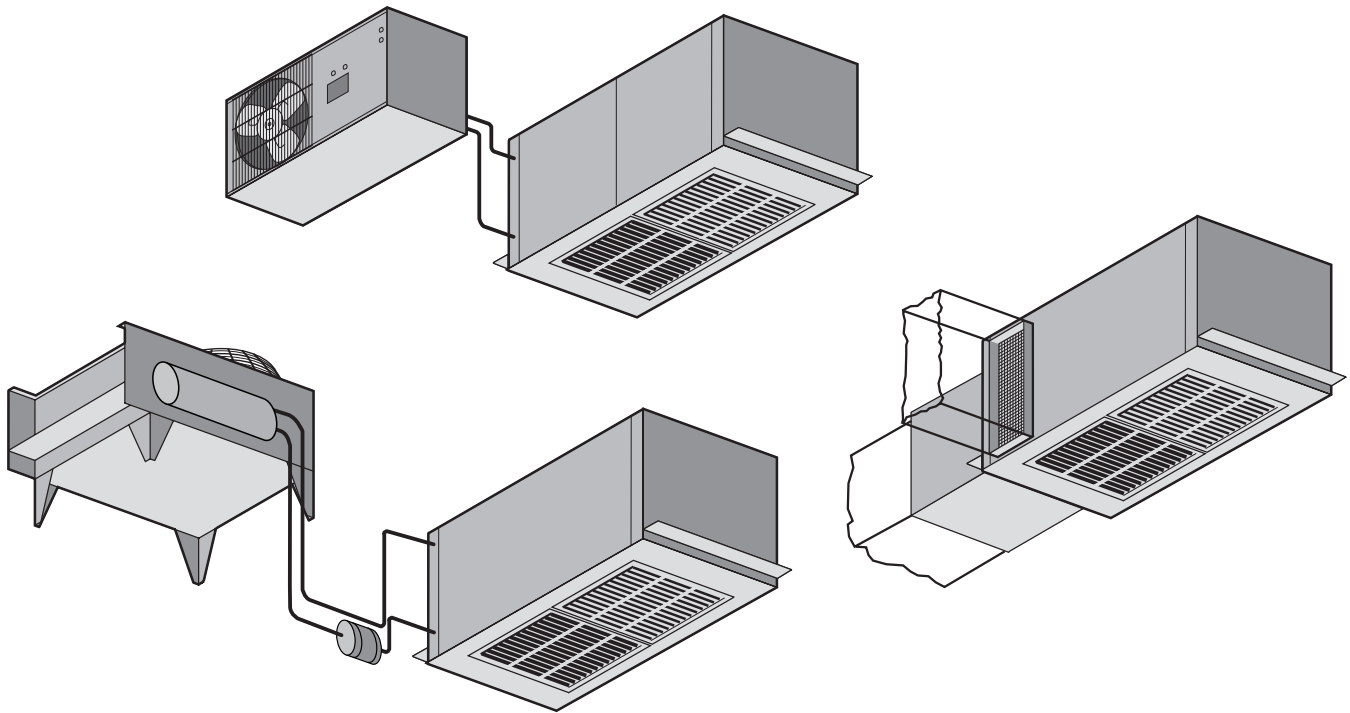


# Liebert Mini-Mate2™

Installation, Operation and Maintenance Manual - 1-1.5 Tons, 50 & 60Hz



For More Information:  
(866) 787-3271  
Sales@PTSdcs.com





---

# Table of Contents

<b>PRODUCT MODEL INFORMATION</b>	<b>1</b>
<b>1.0 INTRODUCTION</b>	
1.1 Production Description and Features	3
1.1.1 Controls	3
1.1.2 System Components	3
1.2 Optional Equipment	3
1.2.1 Ancillary (Ship Loose Accessories)	4
1.2.2 Remote Monitoring and Control	5
<b>2.0 SITE PREPARATION AND INSTALLATION</b>	
2.1 Installation Considerations	6
2.1.1 Room Preparation	6
2.1.2 Location Considerations	7
2.2 System Weights	8
2.3 Equipment Inspection (Upon Receipt)	8
2.4 Installing the Ceiling Units	8
2.4.1 Evaporator Air Distribution	9
2.4.2 Piping Connections and Coolant Requirements	9
2.4.3 Condensate Pump Kit Installation	15
2.4.4 Electrical Connections	18
2.5 Centrifugal Condenser Fan Installation	19
2.6 Outdoor Air Cooled Condensing Unit Installation	21
2.6.1 Location Considerations	21
2.6.2 Piping Connections	22
2.6.3 Electrical Connections	22
2.7 Checklist for Completed Installation	24
<b>3.0 MICROPROCESSOR CONTROL</b>	
3.1 Feature Overview	26
3.1.1 Setpoints	27
3.1.2 Status	28
3.1.3 Active Alarms	28
3.1.4 Time	28
3.1.5 Date	28
3.1.6 Setback	29
3.1.7 Setup Operation	29
3.1.8 Change Passwords	30
3.1.9 Calibrate Sensors	30
3.1.10 Alarm Enable	30
3.1.11 Alarm Time Delay	30
3.1.12 Common Alarm Enable	31
3.1.13 Custom Alarms	31
3.1.14 Custom Text	31
3.1.15 Run Diagnostics (Available on Rev 1.001.0)	32

---

<b>4.0</b>	<b>SYSTEM PERFORMANCE MICROPROCESSOR CONTROLS</b>	
4.1	Temperature Control . . . . .	37
4.1.1	Cooling/Heating Required . . . . .	37
4.1.2	Cooling Operation (Cooling, Compressorized Direct Expansion and Chilled Water). . . . .	37
4.1.3	Heating Operation . . . . .	37
4.2	Humidity Control . . . . .	38
4.2.1	Dehumidification/Humidification Required . . . . .	38
4.2.2	Dehumidification Operation, Compressorized Direct Expansion (DX) Systems . . . . .	38
4.2.3	Humidification Operation . . . . .	38
4.3	Load Control Features . . . . .	38
4.4	Communications . . . . .	38
<b>5.0</b>	<b>ALARMS</b>	
5.1	Alarms: Definitions and Troubleshooting . . . . .	39
5.1.1	Custom Alarms . . . . .	39
5.1.2	High Head Pressure . . . . .	39
5.1.3	Humidity Level . . . . .	40
5.1.4	Temperature . . . . .	40
5.1.5	Humidifier Problem Alarm . . . . .	40
5.1.6	High Water Alarm . . . . .	40
5.1.7	Short Cycle . . . . .	40
5.2	Optional/Custom Alarms . . . . .	40
5.2.1	Loss of Water Flow . . . . .	40
5.2.2	Smoke Detected . . . . .	41
<b>6.0</b>	<b>SYSTEM TESTING AND MAINTENANCE</b>	
6.1	System Testing . . . . .	42
6.1.1	Environmental Control Functions . . . . .	42
6.1.2	Cooling . . . . .	42
6.1.3	Heating . . . . .	42
6.1.4	Humidification . . . . .	42
6.1.5	Dehumidification . . . . .	42
6.1.6	Firestat (Optional) . . . . .	42
6.1.7	Smoke Detector . . . . .	42
6.1.8	Remote Shutdown . . . . .	42
6.2	Maintenance . . . . .	43
6.2.1	Electric Panel . . . . .	43
6.2.2	Filters . . . . .	43
6.2.3	Direct Drive Blower Package . . . . .	43
6.2.4	Refrigeration System . . . . .	43
6.3	Replacement Procedures . . . . .	45
6.3.1	Steam Generating Humidifier-Operation Procedures . . . . .	47
6.3.2	Humidifier Circuit Board Adjustments . . . . .	48
<b>7.0</b>	<b>MAINTENANCE INSPECTION CHECKLIST</b>	
<b>8.0</b>	<b>TROUBLESHOOTING</b>	

---

---

## Figures

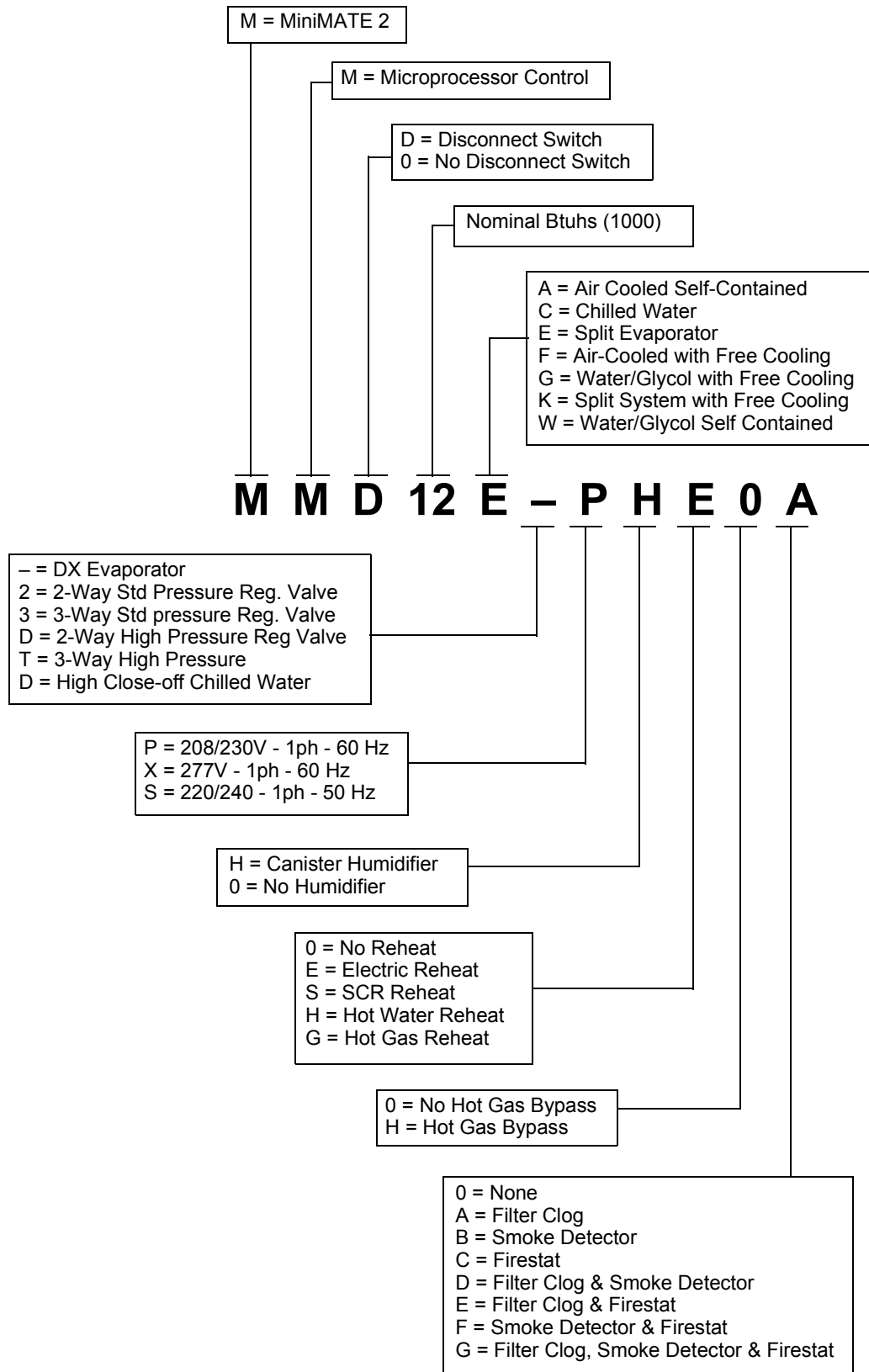
Figure 1	Air Cooled Systems 1 and 5 Tons	7
Figure 2	Water/Glycol Cooled Systems 1 and 5 Tons	7
Figure 3	Split System Air Cooled Systems	8
Figure 4	Unit Dimensional Data	13
Figure 5	Unit Piping Data	14
Figure 6	Condensate Pump	15
Figure 7	General Arrangement Diagram-Split Systems	16
Figure 8	General Arrangement Diagram-Self Contained	17
Figure 9	Unit Electrical Connections	19
Figure 10	Centrifugal Condenser Fan Dimensions and Installations	21
Figure 11	Piping and Electrical Connections	23
Figure 12	Control	26
Figure 13	Control Menu	34
Figure 14	Control Board (Inside Evaporator)	35
Figure 15	Wallbox Board	36
Figure 16	Hot Gas Bypass	45

## Tables

Table 1	Application Limits - Evaporator and Chilled Water Units*	6
Table 2	Application Limits - Outdoor Air Cooled Condensing Unit	6
Table 3	Application Limits - Water/Glycol Cooled Condenser	6
Table 4	Unit Weights	8
Table 5	Recommended Line Sizes O.D. Cu.	11
Table 6	Connection Sizes and Torque	11
Table 7	Unit Dimensions-Inches (mm)	22
Table 8	Piping and Electrical Connections	23
Table 9	1 and 1.5-Ton Units	25
Table 10	Line Sets	25
Table 11	View Default Setpoints and Allowable Ranges	28
Table 12	Logging a Setback Plan	29
Table 13	Set-Up Functions, Default Values and Allowable Ranges	30
Table 14	Alarm Default Time Delays	31
Table 15	Equipment Switch Settings (Unit Control Board)	32
Table 16	Switch Settings (Wallbox Board)	32
Table 17	Cooling and Dehumidification Load Response of Hot Bypass	37
Table 18	Typical Discharge Pressures	43
Table 19	DIP switch Settings for Humidifier Control Board	48
Table 20	Troubleshooting	50



# PRODUCT MODEL INFORMATION



---



---

## 1.0 INTRODUCTION

---

### 1.1 Production Description and Features

The Mini-Mate2 is a temperature/humidity control system designed to be installed above a 2' x 4' ceiling grid system. The unit is available as a self-contained air-cooled, self-contained water/glycol, self-contained chilled water, or as a split system evaporator with an Outdoor Prop Fan Condensing Unit.

#### 1.1.1 Controls

The Mini-Mate2 system includes a wall-mounted display panel that includes a liquid crystal display (LCD) screen and an 8 membrane keypad. The control is menu-driven for ease of use.

**Figure 13 - Control Menu** (In section **3.0 - Microprocessor Control**) depicts the complete menu tree for the control. All control set points and alarm set points are programmable.

#### 1.1.2 System Components

##### Air Cooled Models

There are two types of air-cooled systems available:

- **Self-Contained (with Indoor Centrifugal Condenser Blower Included):** Mounted inside the ceiling unit housing, the self-contained system includes: compressor; evaporator coil, expansion valve; evaporator blower; high-pressure switch; condenser coil; and filter drier. The centrifugal condenser blower (up to 950 CFM), with variable speed motor, is contained in a separate enclosure that attaches to the main unit. Head-pressure is regulated by the Fan Speed Controller (FSC), which automatically adjusts blower speed as required. The condenser section can use air with a temperature range of -20°F to 115°F (-29°C to 46°C).
- **Split System (Outdoor Propeller Fan Included):** The evaporator section includes evaporator coil, expansion valve; evaporator blower; and filter drier.

Mounted in an outdoor enclosure, the prop-fan condensing unit includes: compressor with crankcase heater; high pressure switch; condenser coil; propeller fan; and flood back head pressure control (Lee-Temp). The compressor crankcase heater and head pressure control allows the condensing unit to operate at an ambient temperature as low as -30°F (-4°C). The maximum design ambient temperature is 115°F (46°C). The condensing unit is connected to the evaporator unit by two refrigerant lines and low voltage wiring.

##### Water/Glycol Cooled Model

Includes the following components mounted in the main (evaporator) unit housing: compressor; evaporator coil, expansion valve; evaporator blower high-pressure switch; coaxial condenser; 2-way (optional 3-way) regulating valve; and filter drier. This model is specifically designed to operate with city water, cooling tower systems or dry cooler systems. Dry cooler and pumps may be selected separately.

##### Chilled Water Model

The Chilled Water model is self-contained and is designed for use with an existing chilled water loop. It contains a chilled water coil; and a slow open/close solenoid valve to control the flow of chilled water.

### 1.2 Optional Equipment

#### Canister Humidifier

The optional, factory installed steam generating humidifier adds pure water vapor to the room air to control humidity. Room humidity setpoints are established by the user. The humidifier components include: a steam canister (replaceable), control board, inlet strainer, fill and drain solenoids.

---

## **Electric Reheat**

The optional electric reheat is installed and tested at the factory. The reheat feature is energized when required to heat room air or to control room temperature during dehumidification. A safety thermostat prevents the reheat from exceeding temperature limits.

## **SCR Electric Reheat**

The optional electric reheat is pulsed rapidly to provide precise temperature control, while cooling is locked on. A safety thermostat prevents the reheat from exceeding temperature limits.

## **Hot Water Reheat**

The optional hot water reheat circulates building hot water through a y-strainer, solenoid valve and finned-tubed heating coil to provide reheat.

## **Hot Gas Reheat**

Hot gas from the compressor is piped to a heating coil and valve, which can only be energized during compressor operation. The compressor must be operating and a cooling load must be present in order to achieve reheating performance.

## **Hot Gas Bypass (Self-Contained Systems)**

Hot gas from the compressor is bypassed to the evaporator coil in order to provide capacity control and reduce compressor cycling.

## **Hot Gas Bypass (Split System Condensing Units)**

This optional system bypasses hot gas around the compressor directly to suction to provide capacity control and reduce compressor cycling. System includes liquid injection valve to maintain proper suction superheat.

## **Free-Cooling Coil**

A separate source of chilled water (or cold tower water) can be used to provide cooling. Upon loss of the chilled water source, cooling is switched to DX cooling.

## **Smoke Detector**

If return air smoke is detected, the unit alarm panel (display) emits an audible signal and the unit shuts down.

## **Firestat**

When the return air temperature limit of approximately 125°F (51.7°C) is exceeded the unit shuts down.

## **Filter Clog**

An adjustable pressure differential switch emits an audible signal when high differential pressure (e.g., dirty filters) is detected.

### **1.2.1 Ancillary (Ship Loose Accessories)**

#### **Refrigerant Line Sweat Adapter Kit**

This kit includes the compatible fittings required (two suction and two liquid line connections) when using field supplied interconnecting refrigerant lines (to outdoor condensing unit), instead of the pre-charged line sets.

#### **Pre-Charged Refrigerant Line Sets**

Pre-charged refrigerant line sets are available in 15 and 30 foot lengths for 1 and 1.5-ton systems, and are factory-charged and sealed. They are used to connect the evaporator to remote Air Cooled Condensing units. Each set includes an insulated copper suction line and a copper liquid line with fittings.

---

### **Supply and Return Grille Kit**

Supply and return air grilles fit within a 2'x 4' ceiling tile and include a return air filter.

### **Duct Kit with Return Air Filter Box**

A return air filter box with duct flange, 4" (102mm) filter, and a supply air duct flange are provided for ducting the evaporator air.

### **Condensate Pump Kit**

A condensate pump is required when the evaporator is installed below the level of the gravity-fed drain line. Components include: the pump; check valve; sump; level sensor; float switch; and controls. The condensate pump kit is field-mounted to the side of the evaporator housing, where it automatically controls the water level in the sump.

## **1.2.2 Remote Monitoring and Control**

### **Remote Monitoring and Control**

Liebert can provide a variety of remote monitoring and control devices to enhance your Mini-Mate2 system. These include water detection, remote monitoring of a single unit, and remote control/monitoring of multiple units.

### **Remote Sensors**

Remote temperature/humidity sensors can be mounted in the controlled space or in ductwork and includes 30 feet of control cable.

---

## 2.0 SITE PREPARATION AND INSTALLATION

---



### NOTE

Before installing unit, determine whether any building alterations are required to run piping, wiring and ductwork. Carefully follow all unit dimensional drawings and refer to the submittal engineering dimensional drawings of individual units for proper clearances.

### 2.1 Installation Considerations

The evaporator unit is usually mounted above the suspended ceiling in the space to be conditioned. Ducted systems may be located in a different room. Refer to **Figure 1** and **Figure 2** for possible configurations. The system may be:

- Self-Contained Air Cooled with Centrifugal Condenser Fan mounted to the evaporator box.
- Split System Air Cooled with Outdoor Propeller Fan Condensing Units.
- Self-Contained Chiller Water, requiring connection to building chilled water loop.
- Self-Contained Water/Glycol cooled, requiring water or glycol loop connection.

**Table 1 Application Limits — Evaporator and Chilled Water Units\***

Input Voltage		Range of Return Air Conditions to Unit	
Min	Max	Dry Bulb Temp.	Relative Humidity
-5%	+10%	65 to 85°F (10 to 29°C)	20 to 80%

\*Unit will operate at these conditions but will not control to these extremes of conditions.

**Table 2 Application Limits — Outdoor Air Cooled Condensing Unit**

Input Voltage		Entering Dry Bulb Air Temperature	
Min	Max	Min	Max
-5%	+10%	-30°F (34°C) (units with Lee-Temp receiver)	115°F (46°C)

**Table 3 Application Limits — Water/Glycol Cooled Condenser**

Input Voltage		Entering Fluid Temperature	
Min	Max	Min	Max
-5%	+10%	45°F (7°C)*	115°F (46°C)

\*Operation below 65°F (18°C) may result in reduced valve life and fluid noise.

#### 2.1.1 Room Preparation

The room should be well insulated and must have a sealed vapor barrier. The vapor barrier in the ceiling and walls can be a polyethylene film. Paint on concrete walls and floors should contain either rubber or plastic.



### NOTE

The single most important requirement for maintaining environmental control in the conditioned room is the vapor barrier.

Outside or fresh air should be kept to a minimum when tight temperature and humidity control is required. Outside air adds to the cooling, heating, dehumidifying and humidifying loads of the site. Doors should be properly sealed to minimize leaks and should not contain ventilation grilles.



### NOTE

Temperature and humidity sensors are located in the wall box. Carefully select a position for the box where discharge air does not directly blow on the sensors

## 2.1.2 Location Considerations



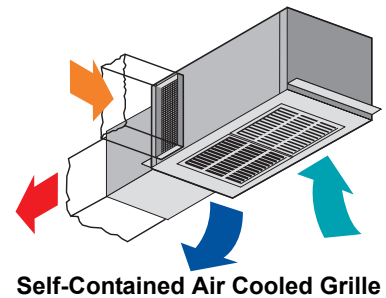
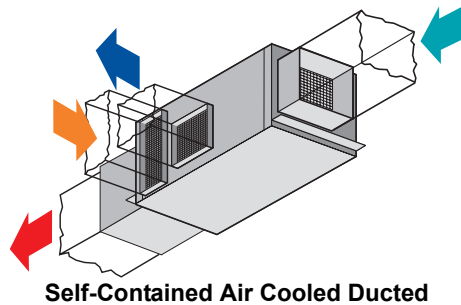
### CAUTION

Units contain water. Water leaks can cause damage to sensitive equipment below. Do not mount units over sensitive equipment. A field supplied pan with drain must be installed beneath cooling units and water/glycol cooled condensing unit.

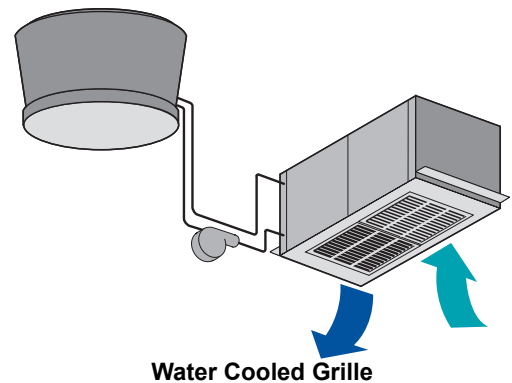
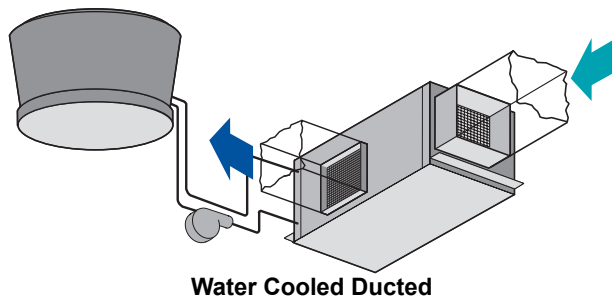
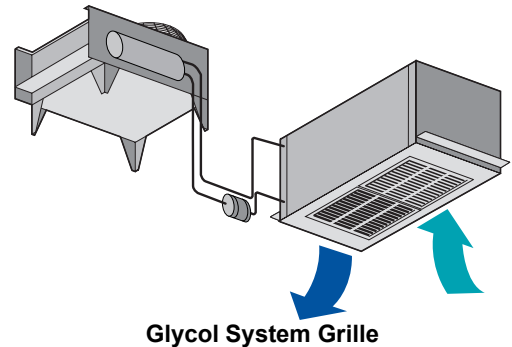
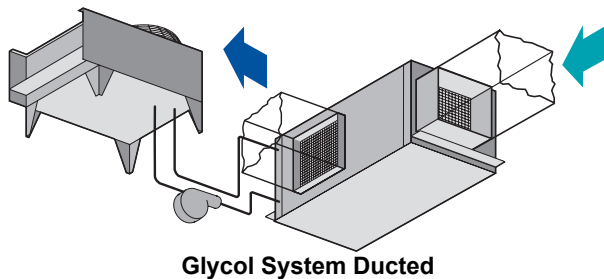
Locate the evaporator unit over an unobstructed floor space if possible. This will allow easy access for routine maintenance or service. Do not attach additional devices (such as smoke detectors, etc.) to the housing, as they could interfere with the maintenance or service.

When using the optional air grille kit, avoid locating the evaporator unit in confined areas that affect the air flow pattern. Such locations could cause short cycles, down drafts and air noise. Avoid locating the unit in an alcove or at the extreme end of a long, narrow room. Avoid installing multiple units close to each other. This could result in crossing air patterns, uneven loads and competing operating modes.

**Figure 1 Air Cooled Systems 1 and 5 Tons**



**Figure 2 Water/Glycol Cooled Systems 1 and 5 Tons**



**Figure 3 Split system air cooled systems**



## 2.2 System Weights

**Table 6 Unit Weights**

Cooling Units*	lb	kg
MMD11A	265	120
MMD11E	220	100
MMD12A	265	120
MMD12E	220	100
MMD13W	260	118
MMD14W	260	118
MMD17A	295	134
MMD17E	225	102
MMD18A	295	134
MMD18E	225	102
MMD19W	300	136
MMD20W	300	136
MMD2CF	63	29

\*Add 40 lb. (20 kg.) to units with free cooling or hot water reheat coils. Weights assume reheat and humidifier package is included.

## 2.3 Equipment Inspection (upon receipt)

When the unit arrives, do not uncrate equipment until it is close to its final location. All required assemblies are banded and shipped in corrugated containers. If you discover any damage when you uncrate the unit, report it to the shipper immediately. If you later find any concealed damage, report it to the shipper and to your Liebert supplier.

## 2.4 Installing the Ceiling Units



### WARNING

**BE SURE THE SUPPORTING ROOF STRUCTURE IS CAPABLE OF SUPPORTING THE WEIGHT OF THE UNIT(S) AND THE ACCESSORIES DURING INSTALLATION AND SERVICE. (SEE 2.2 - SYSTEM WEIGHTS.)**

**BE SURE TO SECURELY ANCHOR THE TOP ENDS OF THE SUSPENSION RODS. MAKE SURE ALL NUTS ARE TIGHT.**

The evaporator unit is usually mounted above the ceiling and must be securely mounted to the roof structure. The ceiling and ceiling supports of existing buildings may require reinforcements.

---

Be sure to follow all applicable codes. Use field-supplied threaded suspension rods and 3/8–16 factory hardware kit.

Recommended clearance between ceiling grids and building structural members is unit height plus 3 inches.

Install the four field-supplied rods by suspending them from suitable building structural members. Locate the rods so that they will align with the four mounting holes in the flanges that are part of the unit base.

Using a suitable lifting device, raise the unit up and pass the threaded rods through the four mounting holes in the flanges that are part of the unit base.

Attach the threaded rods to the unit flanges using the supplied nuts and grommets. (See **Figure 4**).

The rubber grommets provide vibration isolation.

1. Use the plain nuts to hold unit in place. Adjust these nuts so that the weight of the unit is supported evenly by the four rods, does not rest on the ceiling grid, and to ensure the unit is level.



**NOTE**

*The units must be level in order to drain condensate properly.*

2. Use the shake-proof nuts to “jam” the plain nuts.

## 2.4.1 Evaporator Air Distribution

### Filter Box

The optional filter box is available for the unit and mounts directly to the return air opening of the evaporator. The filter box is supplied with a filter measuring 16" x 20" x 4" (406 mm x 508 mm x 102 mm).

### Grille Installation

The airflow grilles are directional devices and **MUST** be installed with the louvers properly aligned in order for unit to operate properly. An air baffle is included with the grille kit and must be installed to ensure proper air distribution. Locate the return and discharge grilles as shown in the grille kit instructions. Lower the grilles into place with the louvers in proper direction. Note that a field-supplied T bar is required between the two grilles. If required, grilles may be screwed directly to sub-base. Install disposable filter (20' x 20" 1") in the return grille. **DO NOT OPERATE THE MINI-MATE2 WITHOUT THE FILTER INSTALLED IN THE RETURN AIR GRILLE.** Refer to instructions shipped with kit for more details. The evaporator unit should be lowered unit gasket material is compressed 1/4" (6 mm).



**CAUTION**

**Do not allow weight of unit to rest on the grills.**

## 2.4.2 Piping Connections and Coolant Requirements

The following pipe connections are required:

- A drain line from the evaporator coil drain pan (This line also serves as the drain for the optional humidifier).
- A water supply line to the optional humidifier (if applicable).
- Refrigerant piping connections between the evaporator unit and the outdoor condensing unit (for split systems). If the evaporator unit is chilled water, connections to the building chilled water source are required.
- Connection to a water or glycol loop on water/glycol type systems.

---

## Drain Line



### CAUTION

**The drain line must not be trapped outside the unit, or water may back-up in the drain pan.**

A 3/4 in. (19 mm) female pipe thread (FPT) connection is provided for the evaporator coil condensate drain. This line also drains the humidifier, if applicable. The drain line must be located so it will not be exposed to freezing temperatures. The drain should be the full size of the drain connection.

The evaporator drain pan includes a float switch to prevent operation if drain becomes blocked.

The optional condensate pump kit is required when the evaporator is installed below the level of the gravity-fed drain line.



### NOTE

*Remove shipping band from the float switch in the evaporator pan before operating unit.*

## Humidifier Water Supply Line

Units supplied with the optional humidifier package have a 1/4 in. (6.4 mm) compression fitting with ferrule at the water supply connection. Supply pressure range is 10 PSIG to 150 PSIG. Required flow rate is 1 gpm. A shut-off valve should be installed in this line to isolate the humidifier for maintenance.

Assembly Instructions:

1. Cut tube square and remove cutoff burr.
2. Slide nut then sleeve on tube, threaded end on nut facing end of tube.
3. Insert tube into fitting seating it against stop shoulder and thread nut to body “handtight”
4. With proper wrench tighten 1¼ to 2¼ turns.



### CAUTION

**Overtightening can damage fittings and/or tube causing leaks.**

**Chilled Water Loop.** On chilled water units install manual service shut-off valves at the supply and return lines of each unit. These shut-off valves are used for routine service or emergency isolation of the unit.

Chilled water supply and return lines must be insulated. Insulating them will prevent condensation of the water supply and return lines to the unit.

The minimum recommended water temperature is 42°F. Design pressure is 300 PSIG. Connection sizes are 1/2" (13 mm) FPT supply and return.

**Water/Glycol Loop.** It is recommended that manual service shut-off valves be installed at the supply and return line to each unit. This enables routine service and/or emergency isolation of the unit. Install ½" (13mm) diameter condensing fluid inlet and ½" (13mm) diameter condensing fluid outlet.

When the condensing fluid quality is poor, it is recommended that proper filters be placed in the supply line. These filters must be easily replaced and/or cleaned to extend the service life of the condenser. The standard maximum fluid pressure is 150 psig (1034 kPa), or optional 350 psig (2413 kPa) systems. For applications above this pressure, consult the factory.

The water/glycol-cooled system will operate in conjunction with a cooling tower, city water or dry-cooler. **AUTOMOTIVE ANTI-FREEZE MUST NEVER BE USED IN GLYCOL SYSTEMS. ALWAYS USE HVAC GLYCOL SOLUTION ONLY THAT HAS BEEN PREPARED BY INDUSTRY PRACTICES.**



---

## Regulating Valve

Water/Glycol cooled units include a coolant flow regulating valve which is factory adjusted and should not need field adjustment.

Standard pressure and high pressure valves are adjusted differently. Contact Liebert Service before making any adjustments.

**Split System, Air-Cooled Model Refrigerant (R-22) Loop.** All split systems require two refrigerant lines (an insulated copper suction line and a copper liquid line) between the evaporator and the outdoor condensing unit.

The refrigerant lines can be piped by:

- Using an optional Sweat Adapter Kit and hard piping between the two units.
- Using optional pre-charged line sets.

All refrigeration piping should be installed with high temperature brazed joints. Prevailing good refrigeration practices should be employed for piping supports, leak testing, evacuation, dehydration, and charging of the refrigeration circuits. The refrigeration piping should be isolated from the building by the use of vibration isolating supports. To prevent tube damage when sealing openings in walls and to reduce vibration transmission, use a soft flexible material to pack around the tubes.

It is important to handle the pre-charged lines with care so they will not get kinked or damaged. Use tube benders and make all bends before making connections to either end. Coil any excess tubing in a horizontal plane with the slope of the tubing toward the condensing unit.

When installing remote condensing units above the evaporator, the suction gas line should be trapped at the evaporator. This trap will retain refrigerant oil in the off cycle. When the unit starts, oil in the trap is carried up the vertical riser and returns to the compressor.



### NOTE

*When installing remote condensing units below the evaporator, the suction gas line should be trapped with an inverted trap the height of the evaporator. This prevents refrigerant migration to the compressor during off cycles.*

**Table 5 Recommended Line Sizes O.D. Cu**

Equivalent Feet	Model Tons	Liquid	Suction
Up to 45	(1 and 1.5)	3/8"	5/8"

**Table 6 Connection Sizes and Torque**

Size OD Cu	Model Tons	Coupling Sizes	Torque lb-ft.
3/8	(1 and 1.5)	#6	10–12
5/8	1 and 1.5)	#11	35–45



### NOTE

*If field supplied refrigerant piping is installed, refrigerant (R-22) must be added to the system.*

---

## Quick Connect Fittings



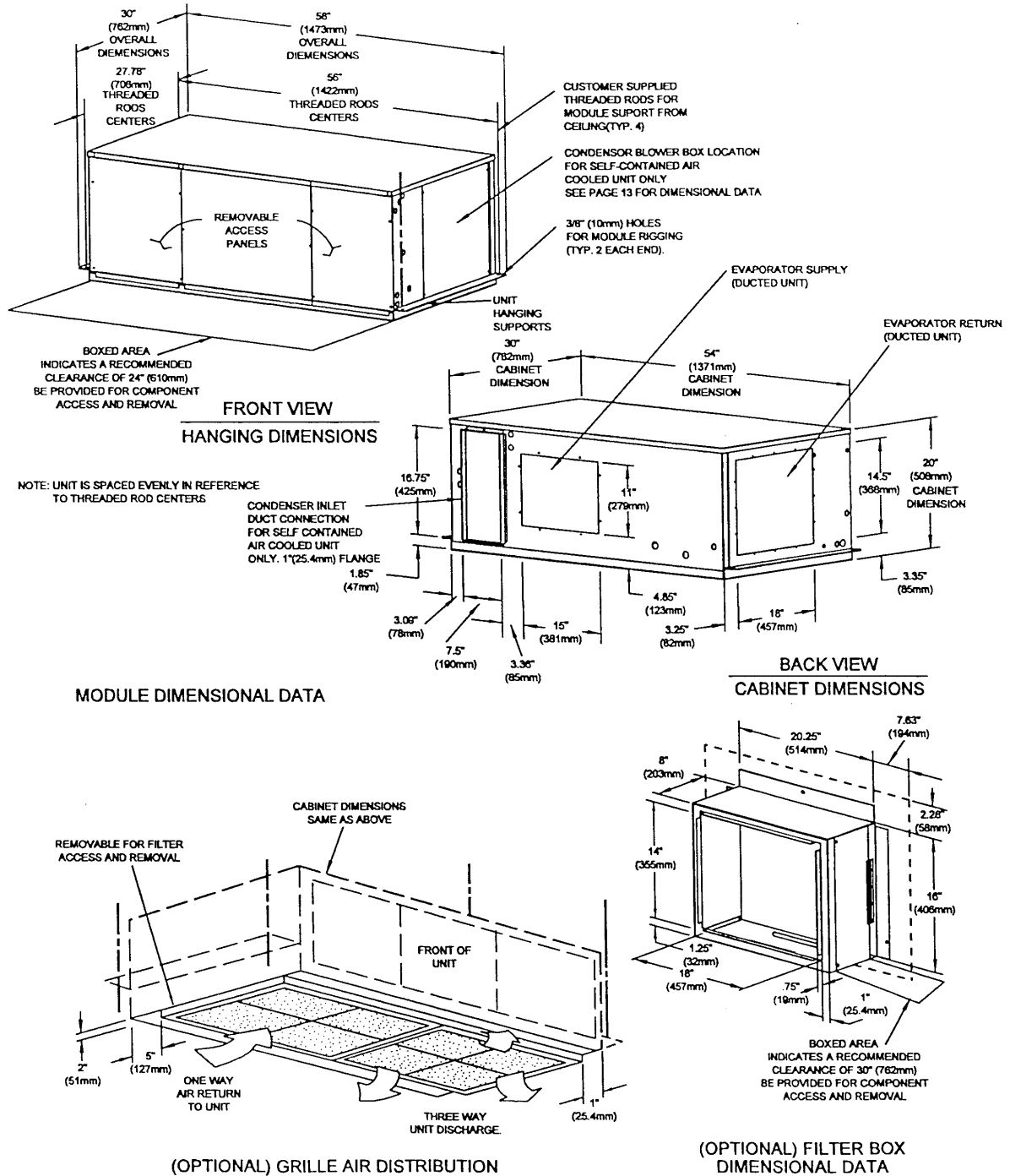
### NOTE

*When hard piping is used, complete all piping and evacuate lines before connecting quick connects.*

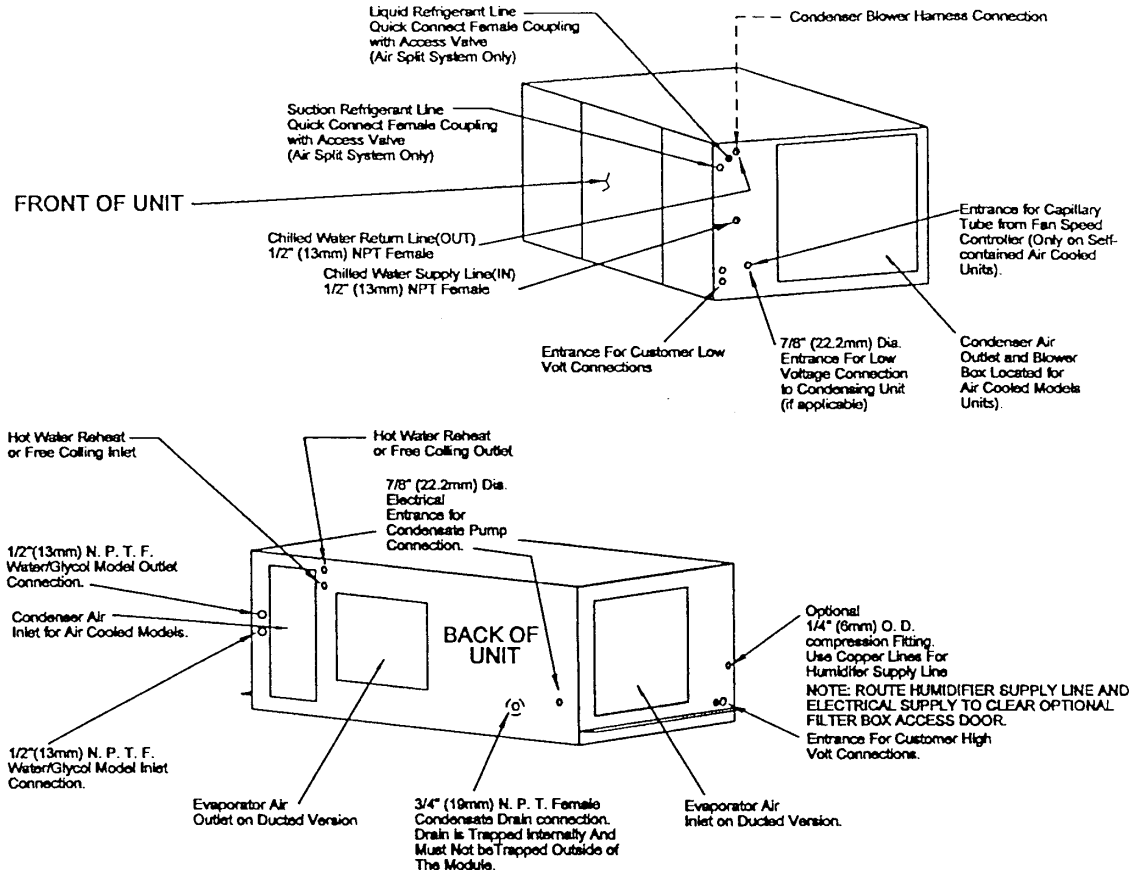
Be especially careful when connecting the quick connect fittings. Read through the following steps before making the connections.

1. Remove protector caps and plugs.
2. Carefully wipe coupling seats and threaded surfaces with a clean cloth.
3. Lubricate the male diaphragm and synthetic rubber seal with refrigerant oil.
4. Thread the coupling halves together by hand to insure that the threads mate properly.
5. Tighten the coupling body hex nut and union nut with the proper size wrench until the coupling bodies “bottom out” or until a definite resistance is felt.
6. Using a marker or pen, make a line lengthwise from the coupling union nut to the bulkhead.
7. Tighten the nuts an additional quarter-turn; the misalignment of the lines shows how much the coupling has been tightened. This final quarter-turn is necessary to insure that the joint will not leak. Refer to **Table 6** for torque requirements.

**Figure 4 Unit Dimensional Data**



**Figure 5 Unit Piping Data**



## 2.4.3 Condensate Pump Kit Installation

### All Units

1. Refer to detail instructions and drawings supplied with the pump.
2. Disconnect all power to the unit.
3. Remove access panels.



### NOTE

*Remove shipping band from float switch in evaporator pan*

4. Use mounting brackets if pump is not attached to ductwork. Pump inlet must be at least 1/2 in. below evaporator drain. Mount the pump to unit exterior as shown in **Figure 6**.
5. Connect 3/4 in. flexible rubber tubing with hose clamp (both supplied with pump kit) to 3/4 in. hose barb fitting on pump.
6. Connect evaporator drain to 3/4 in. FPT hose assembly on pump inlet using 3/4 in. hard pipe, with **no trap** in the line. Provide at least 1 in. clearance between the access panel and the drain line. Support piping as required.
7. Connect a drain line to the pump discharge 3/8 in. O.D. Cu (compression fitting provided).
8. Connect electric leads L1 and L2 to the line voltage terminal block. Connect the ground lead to the lug near the terminal block.
9. Connect wires from the Aux. Pump contacts to terminals TB1-8 and TB1-9 to shutdown unit upon high water condition in the pump.
10. Reinstall the access panels.
11. Reconnect power to the unit.
12. Run the unit to make sure the pump works properly. Operate the pump and check the drain line and discharge line for leaks. Correct as needed.

**Figure 6 Condensate Pump**

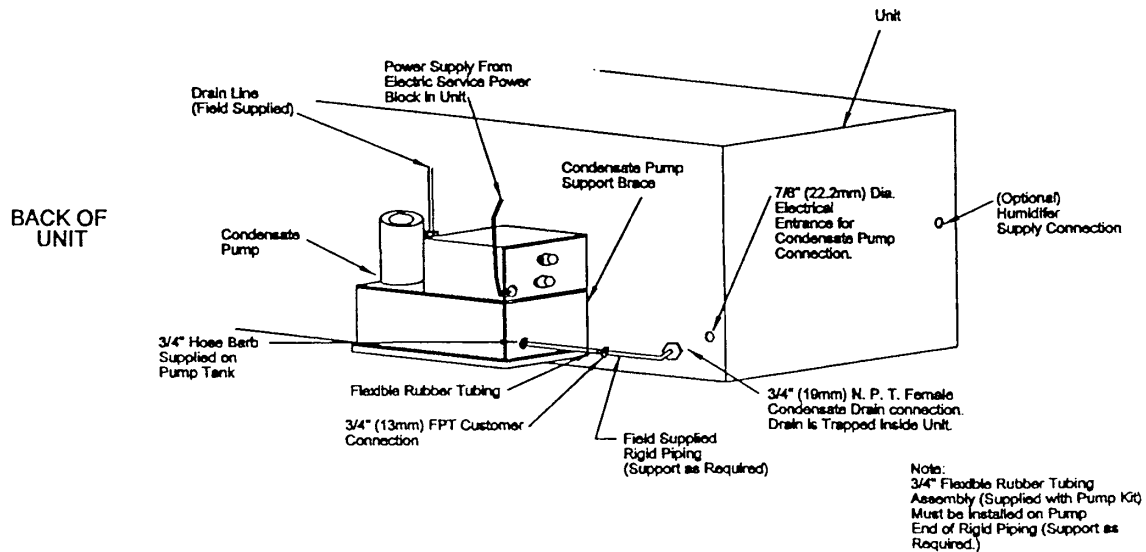


Figure 7 General Arrangement Diagram—Split Systems

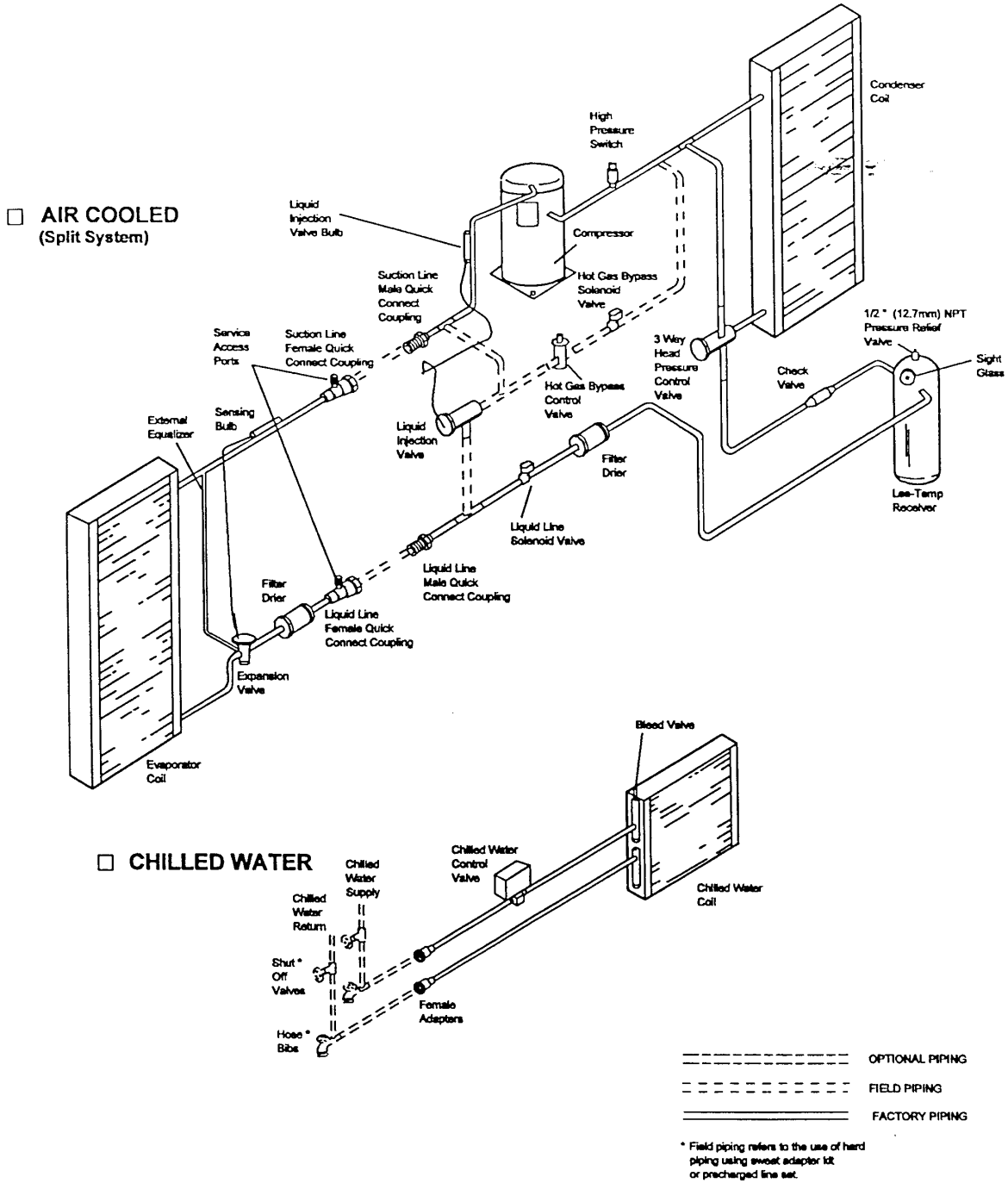
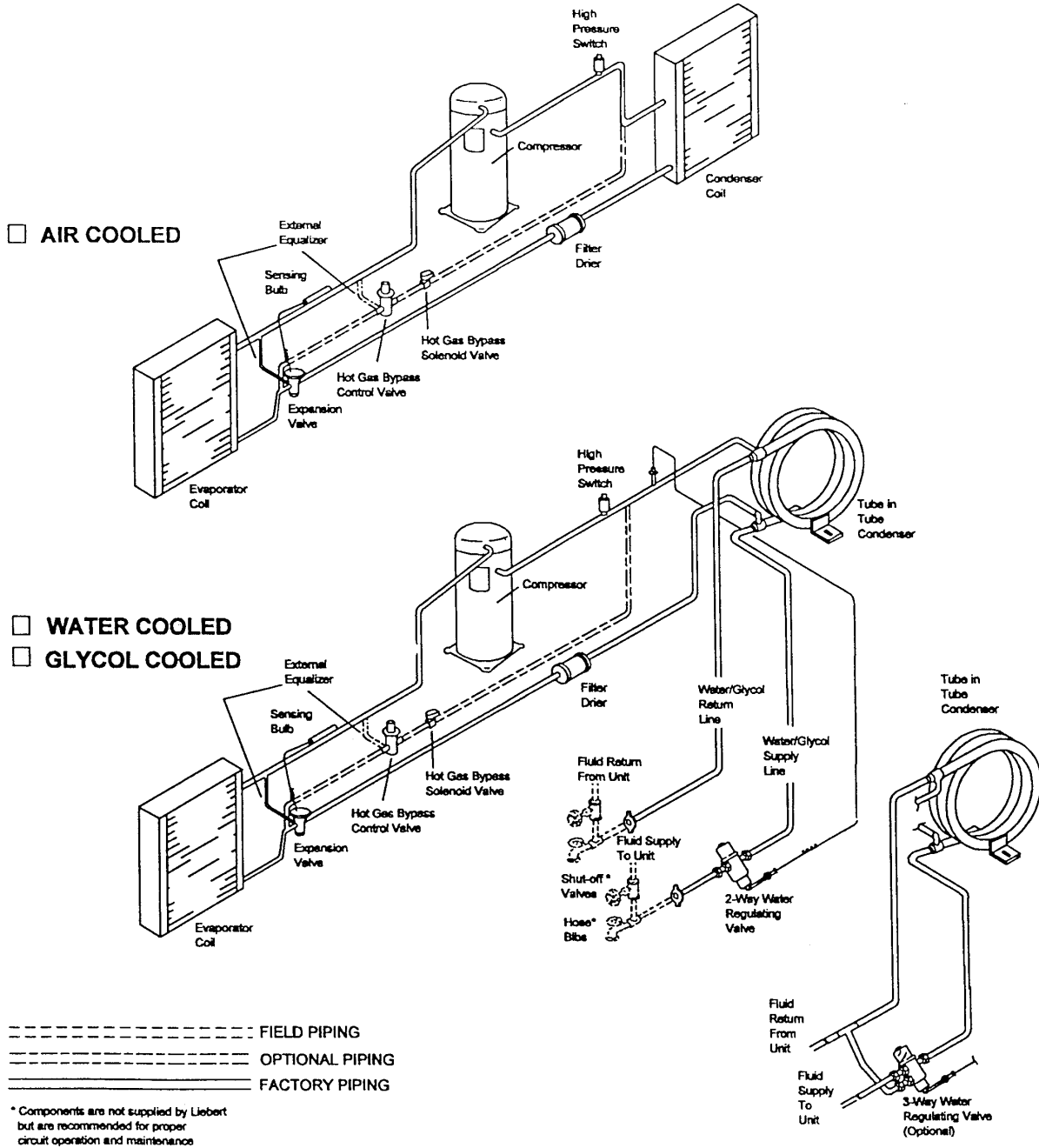


Figure 8 General Arrangement Diagram—Self Contained



---

## 2.4.4 Electrical Connections

Each unit is shipped from the factory with internal wiring completed. Refer to electrical schematic when making connections. Electrical connections to be made at the installation site are:

- Power supply to each ceiling unit.



### WARNING

**UNIT CONTAINS HAZARDOUS ELECTRICAL VOLTAGE.  
DISCONNECT POWER SUPPLY BEFORE WORKING WITHIN.  
LINE SIDE OF FACTORY DISCONNECT REMAINS ENERGIZED  
WHEN DISCONNECT IS OFF.**

- Control wiring between the evaporator unit and outdoor condensing unit, if applicable.
- Control the wiring between the control panel (wallbox) and the evaporator unit control board.

### Power Connections

All power and control wiring and ground connections must be in accordance with the National electrical Code and local codes. Refer to Unit serial tag data for electrical requirements.



### CAUTION

**Use copper wiring only. Make sure that all connections are tight.**

Voltage supplied must agree with the voltage specified on the unit name plate. If a field supplied disconnect switch is required, it may be bolted to the ceiling unit, but not to any of the removable panels. This would interfere with access to the unit. Make sure that no refrigerant lines are punctured when mounting the disconnect switch.

Route the electrical service conduit through the hole provided in the cabinet and terminate it at the electric box. Make connections at the factory terminal block or disconnect switch, L1, L2, (L3). Connect earth ground to lug provided. For 208 VAC applications, the low voltage transformer tap must be changed. Refer to the electrical schematic.

### Control Connections

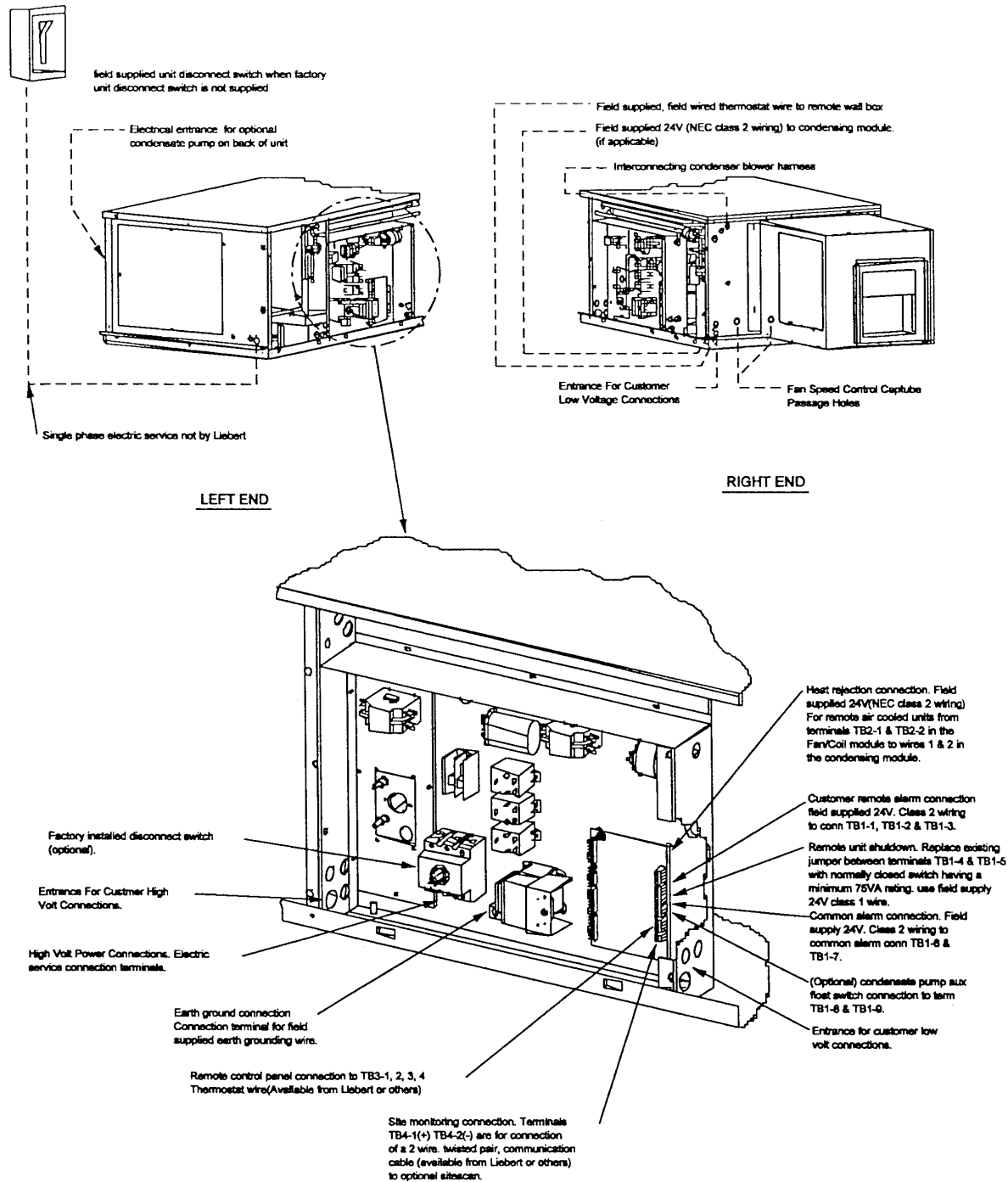
A field-supplied, 3 or 4-wire control connection (24 VAC) is required between the evaporator and the condensing unit. Control wiring must be installed in accordance with the National Electrical Code (NEC) Class 2 circuit. Glycol cooled units also require a two-wire control connection to the drycooler and pump. A Class 1 circuit is required for Water/Glycol units.

Control wiring between the evaporator and the condensing unit must not allow a voltage drop in the line of more than 1 volt (16 gauge minimum for 75 feet). **Do not connect additional electrical devices to the control circuit.** The circuit breaker, contained in the transformer housing, is sized only for the factory-supplied control system.

Additional control wiring will be required if your system includes other optional monitoring and control devices.



**Figure 9 Unit Electrical Connections**



## 2.5 Centrifugal Condenser Fan Installation

The self-contained, air-cooled model utilizes a centrifugal blower in a housing that attaches directly to the right end of the ceiling unit. Mounting holes are pre-cut at the factory and fasteners are provided. In addition, a wiring harness is included for the power and control connections required from the ceiling unit to the blower. Route capillary tube from fan speed controller through hole in ceiling unit. Screw end of capillary tube on to access valve in discharge line. Providing ductwork for outdoor air to/from the condenser is optional.

---

Electrical, Control and Power Connections: Using the provided wiring harness field connections are required at the ceiling unit. A four (4) wire connection is required from the condenser fan to the ceiling unit. Route the conduit through the hole provided in the left side of the cabinet.

If a field-supplied disconnect switch is installed, mount to the ceiling unit, but not on any removable panels. DURING MOUNTING OF EXTERNAL DISCONNECT SWITCH, TAKE SPECIAL CARE THAT NO REFRIGERANT LINES ARE PUNCTURED OR DAMAGED.

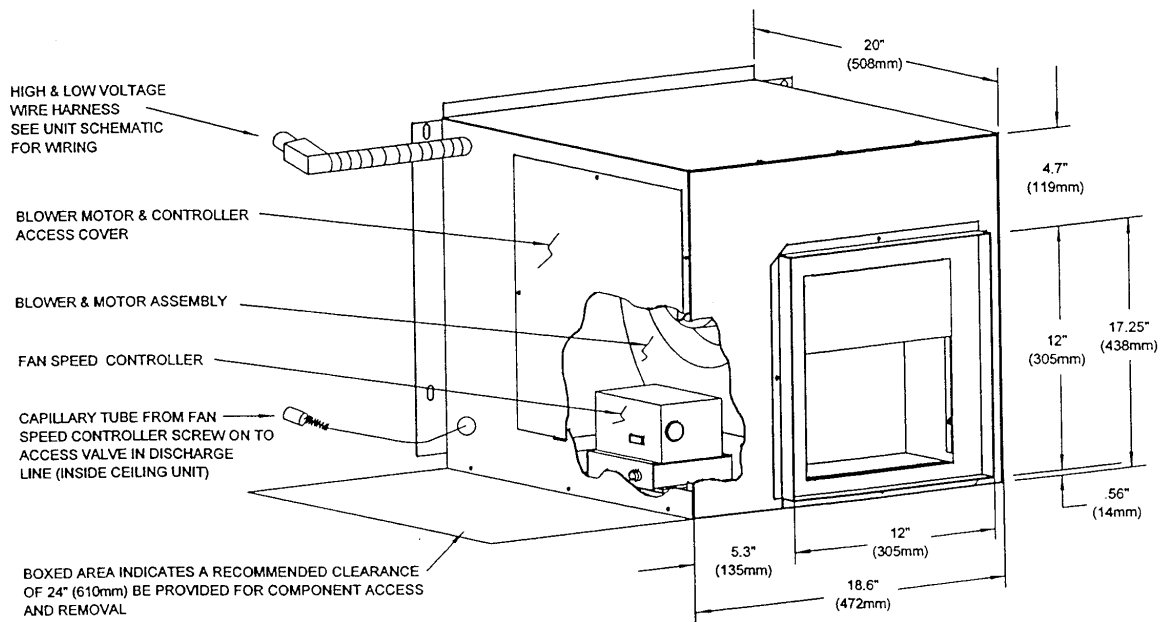
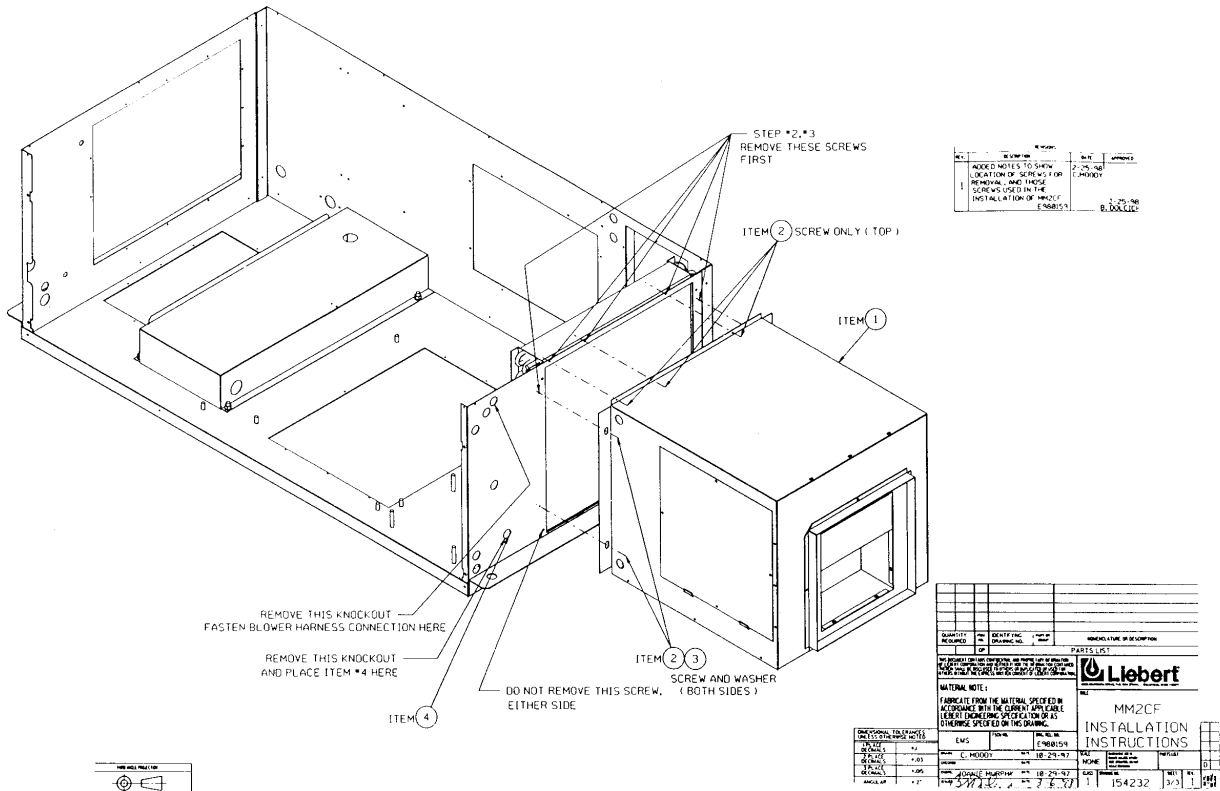
The ceiling unit power connections are made at the terminal block or disconnect switch in the lower left-hand corner of the electric panel (middle). The power terminal connections are labeled L1 and L2. (For 208 VAC applications, change the input transformer connection as described in the electrical schematic attached to cabinet). Self-contained, air-cooled models require power connections from the evaporator ceiling unit to the condenser fan (See **Figure 4**, **Figure 9** and provided electrical schematic). LINE VOLTAGE SUPPLIED MUST CORRESPOND WITH THE VOLTAGE SPECIFIED ON THE UNIT NAMEPLATE.

**Indoor Condenser Fan Ductwork.** The total external static pressure for the inlet and outlet ducts, including grille, must not exceed 0.5 inches of water. Hood intake dimensions should be the same as the condensing unit duct dimensions. The duct connection provided for air flow to the ceiling unit 7½" x 16 ¾" (191mm x 425mm). The duct opening for air flow from the condenser fan is 12" x 12" (305mm x 305mm). Ductwork should be designed for 950 CFM (1614 CMH).

If the unit draws air from the outside of the building, rain hoods must be installed. In addition, install a triple layer bird screen over rain hood openings to eliminate possibility of insects, bird, water or debris entering the unit. Use flexible ductwork or nonflammable cloth collars to attach ductwork to the unit and to control vibration transmission to the building. Attach the ductwork to the unit using the flanges provided. Locate the unit and ductwork so that the discharge air does not short circuit to the return inlet. Avoid directing the hot exhaust air toward adjacent doors or windows.

Normal operating sound may be objectionable if the unit is placed directly over quiet work areas. Ductwork that runs through a conditioned space or is exposed to areas where condensation may occur must be insulated. Whenever possible, ductwork should be suspended using flexible hangers. Avoid mounting the duct directly to the building's structure. In applications where the ceiling plenum is used as the heat rejection domain, the discharge air must be directed away from the air inlet and a screen must be added to the end of the discharge duct to protect service personnel. For multiple unit installation, space the units so that hot exhaust air is not directed toward the air inlet of an adjacent unit.

**Figure 10 Centrifugal Condenser Fan Dimensions and Installations**



## 2.6 Outdoor Air Cooled Condensing Unit Installation

### 2.6.1 Location Considerations

To insure a satisfactory air supply, locate air cooled propeller fan condensing units in an environment providing clear air, away from loose dirt and foreign matter that may clog the coil. Condensing units must not be located in the vicinity of steam, hot air, or fume exhausts, or closer than 18

---

inches from a wall, obstruction, or adjacent unit. Avoid areas where heavy snow will accumulate at air inlet and discharge locations.

The condensing unit should be located for maximum security and maintenance accessibility. Avoid ground-level sites with public access. The recommended maximum refrigerant line length is 45 feet.

Install a solid base, capable of supporting the weight of the condensing unit. The base should be at least 2 inches higher than the surrounding grade and 2 inches larger than the dimensions of the condensing unit base. For snowy areas, a base of sufficient height to clear snow accumulation must be installed.

**Table 7 Unit Dimensions—Inches (mm)**

Model	Width (A)	Height (B)	Depth (C)
PFC013A-_L	40 (1016)	23.5 (597)	18 (457)
PFC014A-_L	40 (1016)	23.5 (597)	18 (457)
PFH014A-_L	40 (1016)	23.5 (597)	18 (457)
PFC019A-_L	40 (1016)	23.5 (597)	18 (457)
PFC020A-_L	40 (1016)	23.5 (597)	18 (457)
PFH020A-_L	40 (1016)	23.5 (597)	18 (457)
PFC026A-_L	40 (1016)	23.5 (597)	18 (457)
PFC027A-_L	40 (1016)	23.5 (597)	18 (457)
PFH027A-_L	40 (1016)	23.5 (597)	18 (457)
PFC026A-_H	48 (1219)	31 (787)	18 (457)
PFH027A-_L	48 (1219)	31 (787)	18 (457)
PFCZ26A-_L	48 (1219)	31 (787)	18 (457)
PFCZ27A-_L	48 (1219)	31 (787)	18 (457)

### 2.6.2 Piping Connections

Details for Refrigerant (R-22) Loop piping are in **2.4.2 - Piping Connections and Coolant Requirements**.

### 2.6.3 Electrical Connections

Refer to **2.4.4 - Electrical Connections**, for general wiring requirements and cautions. Refer to electrical schematic when making connections.

#### Power Connections

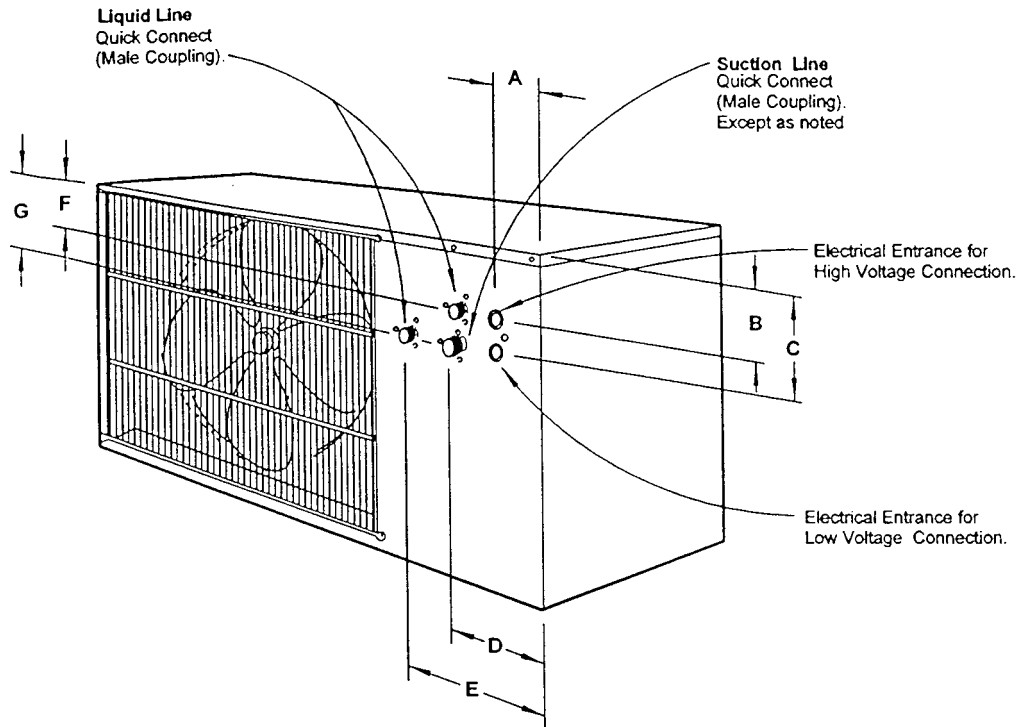
The outdoor condensing unit requires its own power source and earth ground, with a disconnect switch (field supplied) to isolate the unit for maintenance. A transformer is available for 277 VAC, single phase, applications.

#### Control Connections

Field-supplied control wires must be connected between the evaporator and the condensing unit. (See **Figure 9** and the electrical schematic on the units for more details.)

Three (3) wires are required between the evaporator and condensing unit. A fourth wire is required on systems with hot gas bypass.

**Figure 11 Piping and Electrical Connections**



**Table 8 Piping and Electrical Connections**

Model Numbers		Electrical Connections in. (mm)			Piping Connections in. (mm)			
60 Hz	50 Hz	A	B	C	D	E	F	G
PFC014A-L	PFC013A-L	2¼ (57)	5¼ (133)	7¼ (197)	8¼ (222)	-	5 (127)	7¼ (184)
PFH014A-L								
PFC020A-L	PFC019A-L							
PFH020A-L								
PFC027A-L	PFC026A-L							
PFH027A-L								
PFC027A-H	FFC026A-H	2 (51)	5¾ (146)	8½ (216)	4¾ (121)	6¾ (171)	-	8½ (216)
PFH027A-H	PFCZ26A-L							
PFCZ27A-L								
PFC037A-L	PFC036A-L	2 (51)	6 (152)	8½ (216)	4¾ (121)	7¾ (197)	-	8½ (216)
PFH037A-L								
PFC042A-L	PFC041A-L							
PFH042A-L								
PFC037A-H	PFC036A-H							
PFC037A-H	PFCZ36A-L							
PFCZ37A-L								
PFC042A-H	PFC041A-H	2 (51)	6 (152)	8½ (216)	4¾ (121)	7¾ (197)	-	8½ (216)
PFH042A-H	PFCZ41A-L							
PFCZ42A-L								
PFC054A-L	PFC053A-L							
PFH054A-L								
PFC067A-L	PFC066A-L							
PFH067A-L								

---

## 2.7 Checklist for Completed Installation

- 1. Proper clearance for service access have been maintained around the equipment.
- 2. Equipment is level and mounting fasteners are tight.
- 3. Piping completed to refrigerant or coolant loop (if required). Refrigerant charge added (if required).
- 4. Condensate pump installed (if required).
- 5. Drain line Connected.
- 6. Water supply line connected to humidifier (if required).
- 7. All piping connections are tight.
- 8. Field provided pan with drain installed under all ducted cooling units.
- 9. Filter box installed on ducted units.
- 10. Ducting completed or optional grille installed.
- 11. Filter(s) installed in return air duct.
- 12. Line voltage to power wiring matches equipment nameplate.
- 13. Power wiring connections completed between disconnect switch, evaporator, and condensing unit, including earth ground.
- 14. Power line circuit breakers or fuses have proper ratings for equipment installed.
- 15. Control wiring connections completed to evaporator and condensing unit (if required), including wiring to wall-mounted control panel and optional controls.
- 16. Control panel DIP switches set based on customer requirements.
- 17. All wiring connections are tight.
- 18. Foreign materials have been removed from in and around all equipment installed (shipping materials, construction materials, tools, etc.)
- 19. Fans and blowers rotate freely without unusual noise.
- 20. Inspect all piping connections for leaks during initial operations. Correct as needed.

### Refrigerant Charge Requirements

Total refrigerant charge (R-22) will be required only if units are evacuated during installation or maintenance. For safe and effective operation, refer to pressures in **2.4.2 - Piping Connections and Coolant Requirements**.

---

## Total Refrigerant = Units and Lines

Table 9 1 and 1.5-Ton Units

Model No.	Charge	
	oz.	kg.
MMD11A	42	1.2
MMD12A	42	1.2
MMD13W	27	0.8
MMD14W	27	0.8
MMD11E	3	0.09
MMD12E	3	0.09
MMD17A	49	1.4
MMD18A	49	1.4
MMD19W	34	1.0
MMD20W	34	1.0
MMD17E	4	.11
MMD18E	4	.11

Table 10 Line Sets

Line Size	Length	Charge	
		oz	kg
3/8 liq, 5/8 suct	15	0-10	0.28
	30	1-4	0.57

Refrigerant (R-22) must be added to field refrigerant piping.

---

## 3.0 MICROPROCESSOR CONTROL

---

The Microprocessor Control for the Liebert Mini-Mate2 unit features an easy to use menu-driven LCD display. The menus, control features and circuit board details are described in this section. Detailed information concerning controls (4.0 - **System Performance Microprocessor Controls**) and alarms (5.0 - **Alarms**) is provided.

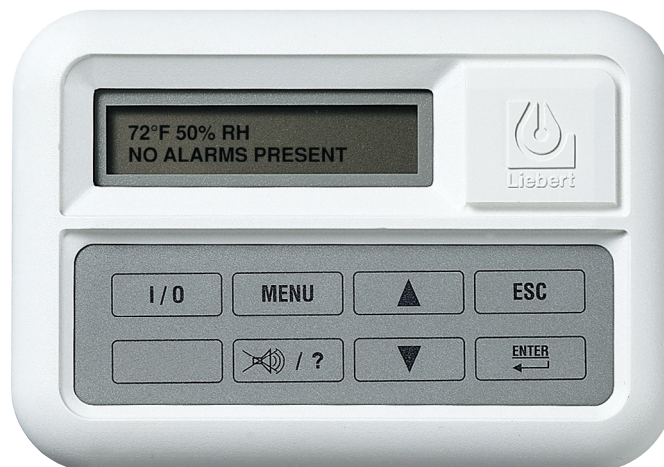
### 3.1 Feature Overview

To turn the unit ON, press the ON/OFF (I/O) key after power is applied. To turn the unit OFF, press the ON/OFF (I/O) key before power is disconnected.

The following control keys may be used to move through the menus, as prompted on the LCD display:

- ON/OFF (I/O) – Turns unit on or off (top far left).
- Menu – Enables user to access the program menu to change control parameters, alarms, set-back schedule, etc. (top near left).
- Increase (UP) – Raises the value of displayed parameter while in a set mode (setpoints, time, etc.) (Arrow-top near right).
- Escape (ESC) – Allows user to move back to a previous menu (top far right).
- Fan High/Low – Pressing this keypad changes the fan speed between high and low fan speed (bottom far left).
- Alarm Silence/Help – If an alarm is present, pressing this keypad will silence the alarm. If this key is pressed when no alarms are present, help text will appear (bottom near left).
- Decrease (DOWN) Arrow – Lowers the value of displayed parameter while in a set mode (bottom near right).
- Enter – After setting a control point, press “Enter” to store the information in the microprocessor (bottom far right).

**Figure 16 Control**



Active alarms are displayed on the LCD screen and sound an audible beep. To silence an alarm, press the Alarm Silence/Help key as prompted on the display.

Setpoints, DIP switch settings, and other selections were made during factory testing of your unit and are based upon typical operating experience. (Other default selections were made according to options included with your unit.) **MAKE ADJUSTMENTS TO THE FACTORY DEFAULT SELECTIONS ONLY IF THEY DO NOT MEET YOUR SPECIFICATIONS.**

Allowable ranges are displayed by pressing the Help key. A password will be required (if enabled) to change setpoints, time delays, etc.



---

The display normally shown includes the present room temperature, humidity, active status functions (cooling, heating, dehumidifying, humidifying), normal fan speed/low fan speed, and active alarms. The Status Display may also be selected from the Main Menu.

MAIN MENU <MENU>

Press the MENU key to display the Main Menu. The Menu selections (in the following order) include:

- SETPOINTS
- STATUS
- ACTIVE ALARMS
- TIME
- DATE
- SETBACK
- SETUP OPERATION
- SETPOINT PASSWORD
- SETUP PASSWORD
- CALIBRATE SENSORS
- ALARM ENABLE
- ALARM TIME DELAY
- COMMON ALARM ENABLE
- CUSTOM ALARMS
- CUSTOM TEXT
- DIAGNOSTICS
- END OF MENU

Use the up/down arrow to scroll through the selections, then when ready to select a particular function press “Enter”.

### **3.1.1 Setpoints**

Setpoints and system setup parameters are kept in non-volatile memory. Selecting SETPOINTS from the Main Menu will display the following selections:

- TEMPERATURE SETPOINT
- TEMPERATURE SENSITIVITY
- HUMIDITY SETPOINT
- HUMIDITY SENSITIVITY
- HIGH TEMPERATURE ALARM
- LOW TEMPERATURE ALARM
- HIGH HUMIDITY ALARM
- LOW HUMIDITY ALARM

Scroll through this sub-menu by using the up/down arrow, then press Enter to select a particular function. To change a particular value, press Enter and use the UP/DOWN ARROWS to change

---

the value. When the value has been changed press Enter to store the value. For example to change the temperature setpoint from the main status display.

1. Press Menu key to display main menu.
2. Scroll to “SETPOINTS” using the UP/DOWN ARROW key. Press Enter key.
3. Scroll to “TEMP SETPOINT” using the UP/DOWN ARROW key. Press Enter key.
4. Use the up/down arrow to change the value. Press Enter key.

**Table 11 View Default Setpoints and Allowable Ranges**

Setpoint	Default	Range
Temperature Setpoint	72°F	40-90°F (5-32°C)
Temperature Sensitivity	2.0°F	1-9.9°F (0.6-5.6°C)
Humidity Setpoint	50%	20-80% RH
Humidity Sensitivity	5%	1-30% RH
High Temperature Alarm	80°F	35-95°F (2-35°C)
Low Temperature Alarm	65°F	35-95°F (2-35°C)
High Humidity Alarm	60%	15-85% RH
Low Humidity Alarm	40%	15-84% RH

### 3.1.2 Status

The operator can monitor the percentage heating, cooling, dehumidifying, and humidifying status of the unit by selecting the “STATUS” sub-menu.

### 3.1.3 Active Alarms

The operator can monitor the alarms status by selecting “ALARMS” which will display a “No Alarm Present” or “Alarm XX of YY” alert and description. If more than one alarm is activated, use the **Up/Down Arrow** to scroll through the alarms list. (“XX” reference is the number of the alarm shown, while the “YY” reference is the total number of alarms activated).

### 3.1.4 Time

The controller time clock must be set to allow for the setback control. The clock uses the 24 hour system (i.e., 12 midnight is entered 24:00). To change the time press “Enter” to select the function, then use the up/down arrow to change the first character, press enter to store, press the up/down button to change the section character, press enter to store, etc. THERE IS A BATTERY BACK-UP FOR THE DATE AND TIME FEATURES.

### 3.1.5 Date

The controller date must be set to allow for the setback control To change the date press “Enter”, then use the up/down arrow to change the first character, press enter to store, press the up/down button to change the second character, etc.

---

### 3.1.6 Setback

The microprocessor can be programmed for night and weekend setback. Two (2) events can be programmed for a five-day workweek and two (2) events can be programmed for a two-day weekend. The following table can be used to devise a setback plan.

**Table 12 Logging a Setback Plan**

Event	Weekend	Weekday
Time 1		
Temperature 1		
Sensitivity 1		
Humidity 1		
Humidity Sensitivity 1		
Time 2		
Temperature 2		
Sensitivity 2		
Humidity 2		
Humidity Sensitivity 2		

### 3.1.7 Setup Operation

Selecting Setpoint/Setup from the Main Menu will display the following selections:

- RESTART TIME DELAY
- C/F DEGREES
- HUMIDITY CONTROL METHOD

Use the Up/Down Arrow to scroll through the submenu. Press Enter to select a particular function.

#### Restart Time Delay

This function delays unit restart after main power is restored to the unit. If several systems are operating, the time delays should be set to different values to cause a sequential start. Delay can be set from 0.1 minutes (6 seconds to 9.9 minutes. Setting the value to zero (0) will prevent unit restart when power is restored. In this case, the unit must be restarted manually by pressing the “on/off” button on the keypad.

#### C/F Degrees

The control may be selected to show readings and setpoints in either degrees Fahrenheit (F) or Celsius (C). To change the value use Enter to select this function, then use the Up/Down Arrow to change the value. Press Enter to store the value.

#### Humidity Control Method

The operator may select either relative (direct) or absolute (predictive) humidity control. If “relative” is selected, the RH control is taken directly from the RH sensor. If “absolute” is selected, the RH control is automatically adjusted whenever return air temperature deviates from the desired temperature setpoint (i.e., predictive humidity control). The LCD display will indicate percentage relative humidity for both methods of control. If the “absolute” feature is selected, the adjusted humidity reading will also be shown. When utilizing the predictive humidity control feature, the humidity level is automatically adjusted ~2% RH for each degree difference between the return air temperature and the temperature setpoint.

In terms of relative humidity control, unnecessary dehumidification can result when overcooling occurs during a dehumidification cycle. This is due to a higher than normal RH reading caused by overcooling the room (about 2% RH for each degree of overcooling). This drop in temperature extends the dehumidification cycle. Later, when the dehumidification ends and the temperature rises to the setpoint, the RH reading falls. The final RH reading will then be lower than actually

---

desired. If the temperature drop was significant enough, the percentage RH could be low enough to activate the humidifier.

If the absolute humidity control is selected, over-dehumidification may be avoided. When over-cooling occurs (i.e., causing an increase in the RH reading) the humidity control program estimates what the RH will be when the dehumidification cycle ends and temperature returns to the setpoint. This allows the dehumidification cycle to end at the proper time. The predictive humidity control can greatly reduce energy consumption by minimizing both compressor/reheat operation and elimination unnecessary operation. Use the Up/Down Arrow key to select the desired humidity control method.

Table 13 Set-Up Functions, Default Values and Allowable Ranges

Function	Default	Range
Restart Time Delay	0.1	0 to 9.9 min (0 = manual restart)
C/F Degrees	°F	°C or °F
Humidity Control	Rel	Relative or Absolute

### 3.1.8 Change Passwords

The display will prompt the operator to enter a three digit password when attempting to make changes. The system includes two (2) passwords, one for setpoints and one for setup. The system allows the password to be changed by first entering the default password set at the factory set (1-2-3) for set points and (3-2-1) for setup. The password function provides system security, so that only authorized personnel are allowed to make changes to the system. (If unauthorized changes are being made, the passwords may be compromised and new ones should be selected). The password function can be disabled by setting DIP switch 8 in the Wallbox to OFF.

### 3.1.9 Calibrate Sensors

The temperature and humidity sensor can be calibrated by selecting the CALIBRATE SENSORS menu item. The temperature sensor can be calibrated  $\pm 5^{\circ}\text{F}$ , while the humidity sensor can be calibrated  $\pm 10\%$  RH. When calibrating the humidity sensor, the value shown will always be % RH, even though absolute humidity control may be selected. If absolute humidity control is selected, the Normal Status Display will display the adjusted reading. This reading may not agree with the relative humidity reading displayed while in calibration.

If the sensors are subject to frequent wide temperature and humidity swings, it may be necessary to shorten the cycling by increasing the sensor time delay. If the cycling by increasing the sensor time delay. If the sensors are located too close to the air discharge, they will likely experience rapid swings in measurement. Another method in reducing compressor cycling is to increase the temperature and/or humidity sensitivity.

### 3.1.10 Alarm Enable

Each alarm can be disabled or enabled. Use the Up/Down Arrow to select a particular alarm, press Enter to select either enable or disable. Then press Enter again to store the change. When the alarm is disabled it will NOT report to either the wallbox beeper or the common alarm relay. THE HIGH WATER ALARM WILL AUTOMATICALLY SHUT THE UNIT OFF, EVEN IF THE ALARM IS DISABLED. SIMILARLY, OPTIONAL FACTORY-INSTALLED SMOKE DETECTORS ARE WIRED TO SHUT THE EVAPORATOR UNIT OFF, REGARDLESS OF THE ENABLE/DISABLE STATUS.

### 3.1.11 Alarm Time Delay

Each individual alarm can be programmed with a time delay (**Table 14**), causing the unit to delay a specified amount of time (0-255 seconds) before recognizing the alarm. The alarm condition must be present for the full amount of the time delay before the alarm will sound. If the alarm condition is diverted prematurely, the alarm will not be recognized and the time delay time will

---

automatically reset. FOR SOFTWARE ALARMS SUCH AS “LOSS OF POWER” AND “SHORT CYCLE”, THE TIME DELAY SHOULD BE LEFT AT THE FACTORY DEFAULT OF 0.

**Table 14 Alarm Default Time Delays**

Alarm	Default Time Delay (seconds)
Humidifier Problem	2
High Head Pressure	2
Custom Alarm #1	0
Custom Alarm #2	6
High Temperature	30
Low Temperature	30
High Humidity	30
Low Humidity	30
Short Cycle	0
Loss of Power	0

### 3.1.12 Common Alarm Enable

Each individual alarm can be selected to activate/deactivate the common alarm relay. If the energize common alarm function is set to YES, the relay is energized immediately as the alarm is annunciated and de-energized when the alarm condition is diverted after the alarm has been recognized. If the alarm is completely DISABLED, the alarm has no effect on the common alarm relay. Use the up/down arrows to scroll to a particular alarm, press the Enter button to select it, then press the Enter button again to select Yes or No.

### 3.1.13 Custom Alarms

The custom alarm messages can be selected from a list of standard alarm messages, allowing the operator to write his/her own message. A MAXIMUM OF TWO (2) ALARM MESSAGES CAN BE CUSTOMIZED. The two custom alarm messages will initially display the previously programmed message but can be changed.

The text for custom alarms can be changed at any time by selecting “CUSTOM ALARMS”. To change the text for a custom alarm, select the alarm you would like to change, 1 or 2. Using the UP/DOWN ARROWS, step through the list of five standard alarm messages (listed below) and two custom alarms. Select the alarm message desired and store it by pressing Enter.

- STANDARD CUSTOM ALARM MESSAGES
- WATER FLOW LOSS
- SMOKE DETECTED
- LOSS OF AIR FLOW
- HUMIDIFIER PROBLEM
- FILTER CLOG

### 3.1.14 Custom Text

To modify the two custom alarm messages select “CUSTOM TXT”. Then select “CUS TXT #1” or “CUS TXT #2”. Text can be up to 20 characters in length and can be either a blank space or any of the following alphanumeric characters and symbols:

- A,B,C,D,E,F,G,H,I,J,K,L,M,N,O,P,Q,R,S,T,U,V,W,X,Y,Z
- #,%,\*,-
- 0,1,2,3,4,5,6,7,8 or 9

Use the UP/DOWN ARROWS to select a character, then press Enter. The cursor will move to the next space where you may once use the UP/DOWN ARROWS to select another character, etc.

---

## LCD Contrast

The level of contrast due to the viewing angle of the Liquid Crystal Display (LCD) can be adjusted using a potentiometer screw, inside the wall box next to the display.

## Nonvolatile Memory

All critical information is stored in nonvolatile memory. Setpoints, setup parameters, and component run hours are kept inside the microcontroller in EEPROM.

## Equipment Options Switches

Equipment options are selected and enabled using DIP switches 1 through 7. These are located on the control board near TB1. These switches are factory set and should not require any user changes. The setting and function of the switches can be individually read on the LCD.



### NOTE

*In order to update the DIP switch settings, power must be cycled off, then on, from the unit disconnect switch.*

**Table 15 Equipment Switch Settings (Unit Control Board)**

Switch	OFF Position	ON Position
1	Compressor	Chill Water
2	Staged Reheat	SCR Reheat
3	Not Used—Must remain in OFF position	
4	Not Used—Must remain in OFF position	
5	Enable Reheat	Disable Reheat
6	Enable Humidifier	Disable Humidifier
7	Enable Dehumidifier	Disable Dehumidifier
8	Electric Reheat	Gas Reheat

**Table 16 Switch Settings (Wallbox Board)**

Switch	OFF Position	ON Position
1	Disable Beeper	Enable Beeper
2	Not Used—Must remain in OFF position	
3	Not Used—Must remain in OFF position	
4	Not Used—Must remain in OFF position	
5	Not Used—Must remain in OFF position	
6	Not Used—Must remain in OFF position	
7	Disable Setback	Enable Setback
8	Enable Password	Disable Password

### 3.1.15 Run Diagnostics (Available On Rev 1.001.0)

By selecting Run Diagnostics, maintenance personnel can check system inputs, outputs, and conduct a test of the microcontroller circuit board from the wall box control. A review of the system inputs and the microcontroller test can be done without interrupting normal operation.

#### Show Inputs

With the unit on and the fan running, the input states may be displayed for the following devices:

- High Water Alarm—Normally off unless High Water Alarm is active.
- High Head Pressure Alarm—Normally off unless High Head Pressure Alarm is active.
- Custom alarm #1—Normally off unless this special customer selectable alarm is active.
- Custom alarm #2—Normally off unless this special customer selectable alarm is active.
- Power—Normally on unless unit is turned off through the wallbox or any of the following optional devices: Firestat, Smoke Detector, High Water Alarm, or Remote Shutdown

---

## Test Outputs

When this feature is selected, the unit is effectively turned off. When stepping from one load to the next, the previous load is automatically turned off if it is on. The loads can also be toggled on/off by selecting “ENTER”. Once turned on, the output will remain on for five minutes unless toggled off or the test outputs function is exited by selecting “MENU/ESC” (Compressor is limited to 15 seconds on to prevent damage.)



### CAUTION

**Testing compressor output for more than a few seconds could damage the compressor. To eliminate damaging the compressor during testing, do not test compressor output for more than a few seconds.**



### CAUTION

**Extended unit operation in the test outputs mode for troubleshooting may cause damage to the unit. Do not operate unit in the test outputs mode any longer than is necessary for troubleshooting.**

The outputs are as follows:

- Normal Fan: Normal speed fan contactor
- Low Speed Fan: Low speed fan contactor
- Humidifier: Humidifier contactor
- Cool: Compressor contactor
- HGBP: Hot gas bypass valve
- Reheat: Reheat contactor
- Common Alarm: Common alarm relay



### NOTE

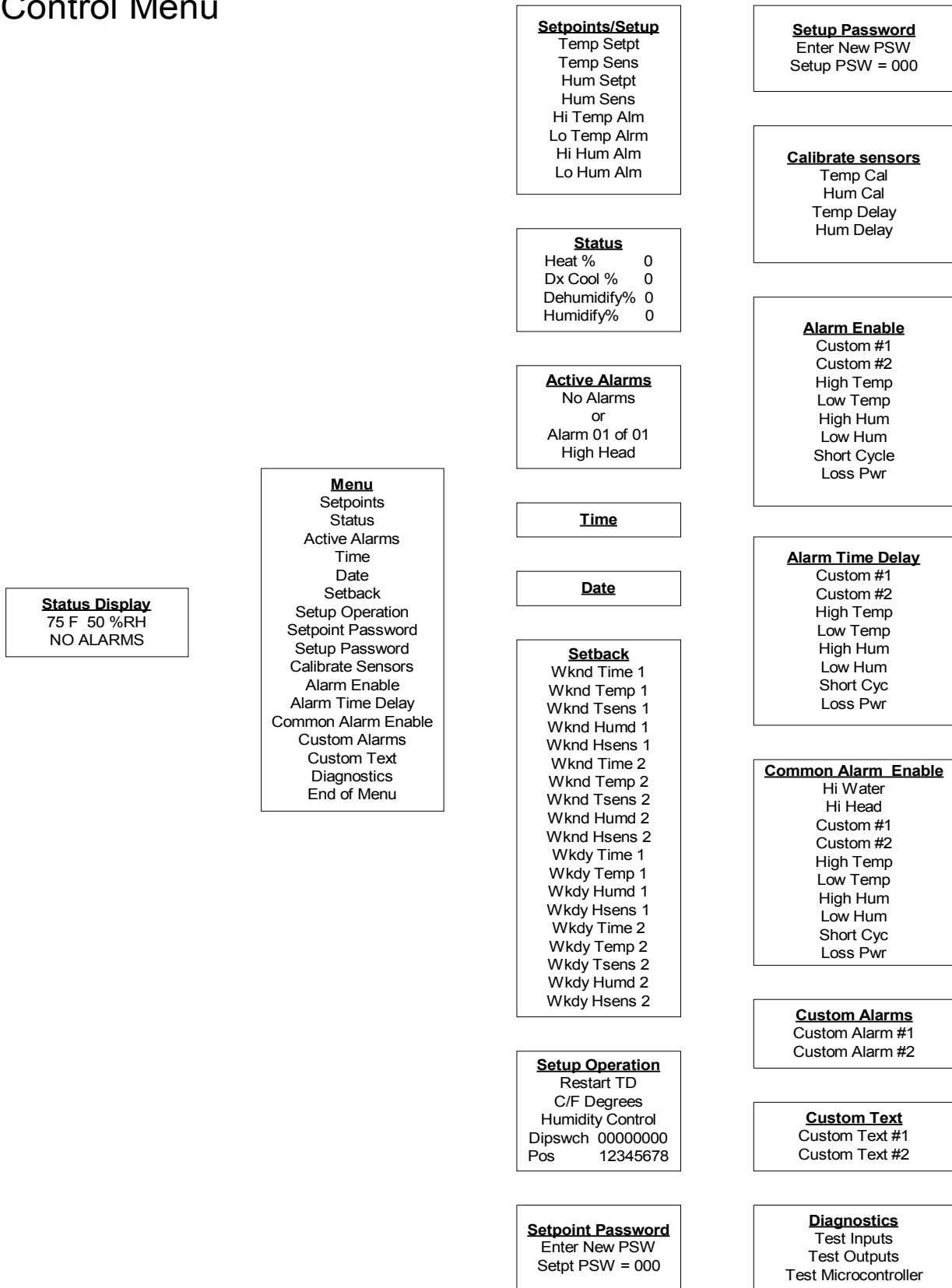
*Fan turned on with all loads.*

## Test Control Board

By selecting this function, the microcontroller will perform a self test lasting approximately 10 seconds. When the test is complete, the display will show the ROM checksum, ROM part number, and firmware version number.

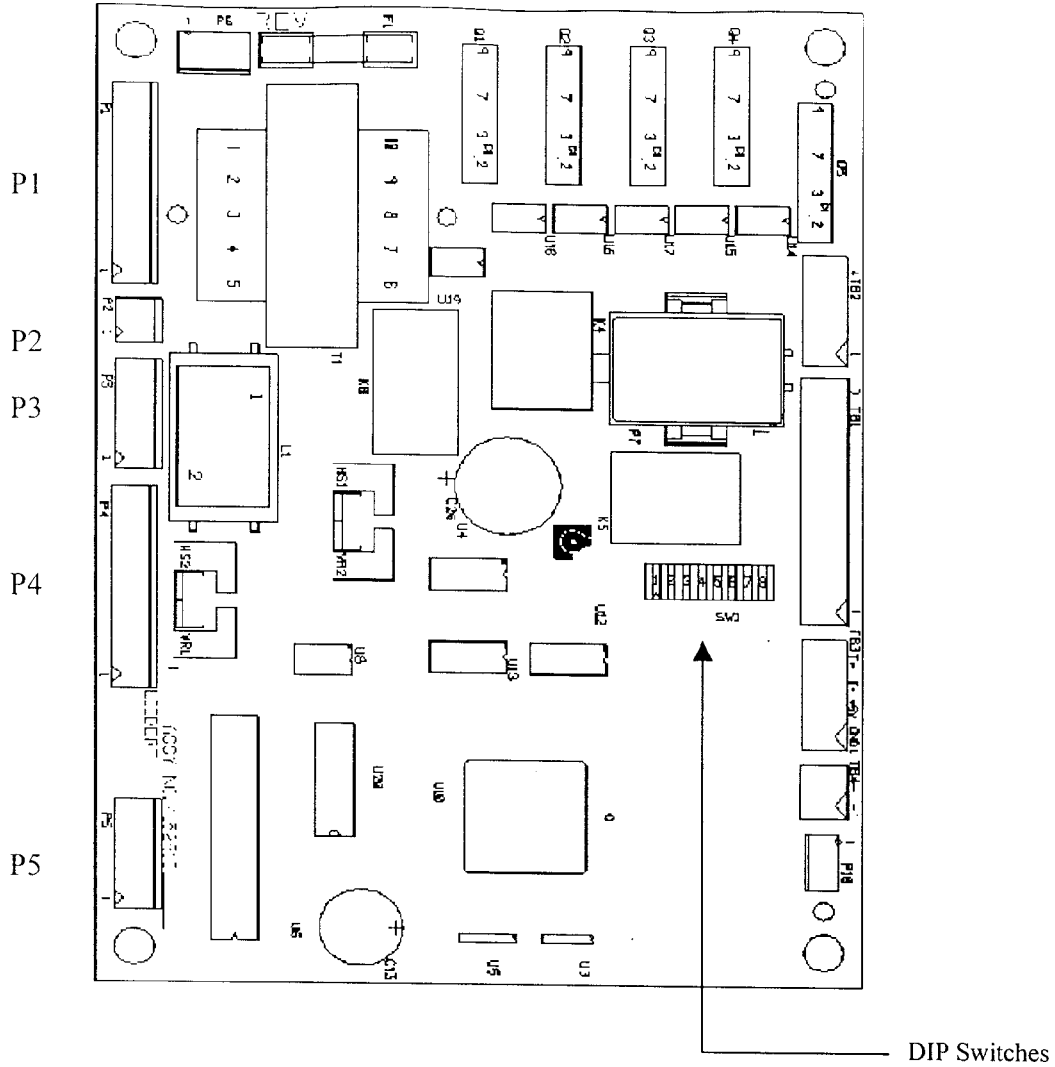
Figure 13 Control Menu

# Mini-Mate 2 Control Menu



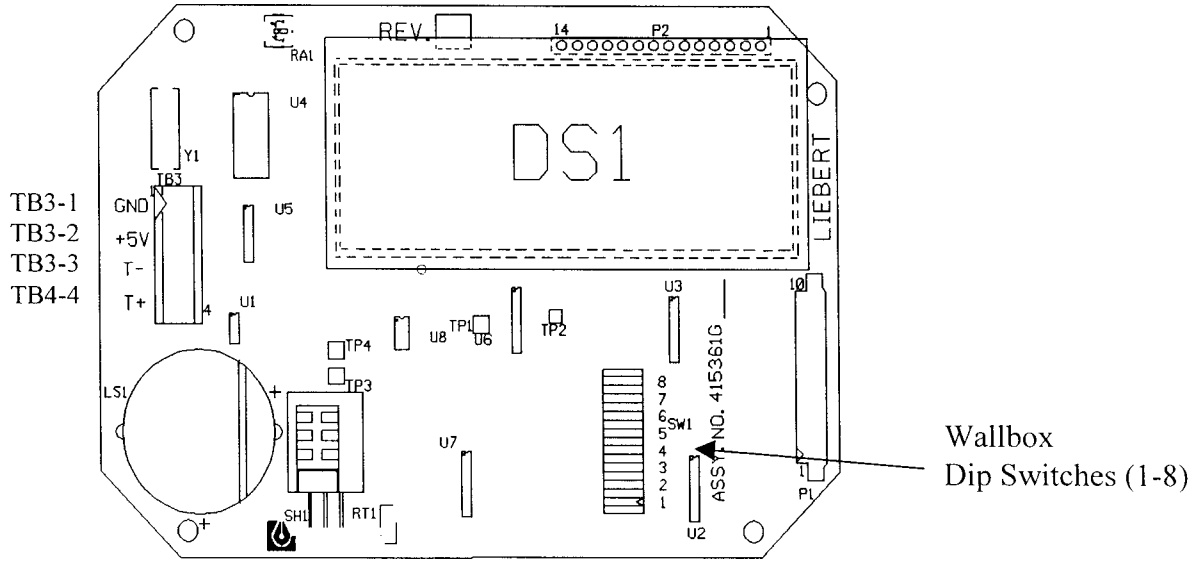


**Figure 14 Control Board (Inside Evaporator)**



TB2-4	Hot Gas Bypass
TB2-3	High Head Alarm Connection
TB2-2	Heat Rejection
TB2-1	Heat Rejection
TB1-9	Condensate Pump Aux Alarm
TB1-8	Condensate Pump Aux Alarm
TB1-7	Common Alarm Connection
TB1-6	Common Alarm Connection
TB1-5	Remote Shutdown
TB1-4	Remote Shutdown
TB1-3	Customer Alarm Connection #2
TB1-2	Customer Alarm Connection #1
TB1-1	Customer Alarm Connection (Common)
TB3-4	Connection to Terminal #4 Wallbox
TB3-3	Connection to Terminal #3 Wallbox
TB3-2	Connection to Terminal #2 Wallbox
TB3-1	Connection to Terminal #1 Wallbox
TB4-2	Site Monitoring Connection (-)
TB4-1	Site Monitoring Connection (+)
P16	Remote Sensor Connection

Figure 15 Wallbox Board



## 4.0 SYSTEM PERFORMANCE MICROPROCESSOR CONTROLS

This section provides a detailed description of how the Mini-Mate2 responds to operator inputs and room conditions.

### 4.1 Temperature Control

#### 4.1.1 Cooling/Heating Required

The temperature control program for the microprocessor is based on a calculated percentage requirement for cooling/heating.

#### 4.1.2 Cooling Operation (Cooling, Compressorized Direct Expansion and Chilled Water)

Cooling is **ACTIVATED** when the temperature control calculates a requirement for cooling of 100%. It is **DEACTIVATED** when the cooling requirement drops below 50%. The optional hot gas bypass is energized when a call for cooling occurs unless there is also a call for dehumidification.

**Table 17 Cooling and Dehumidification Load Response of Hot Gas Bypass**

Situation	Response
Cooling only	ON
Dehumidification only	OFF
Cooling with Dehumidification	OFF

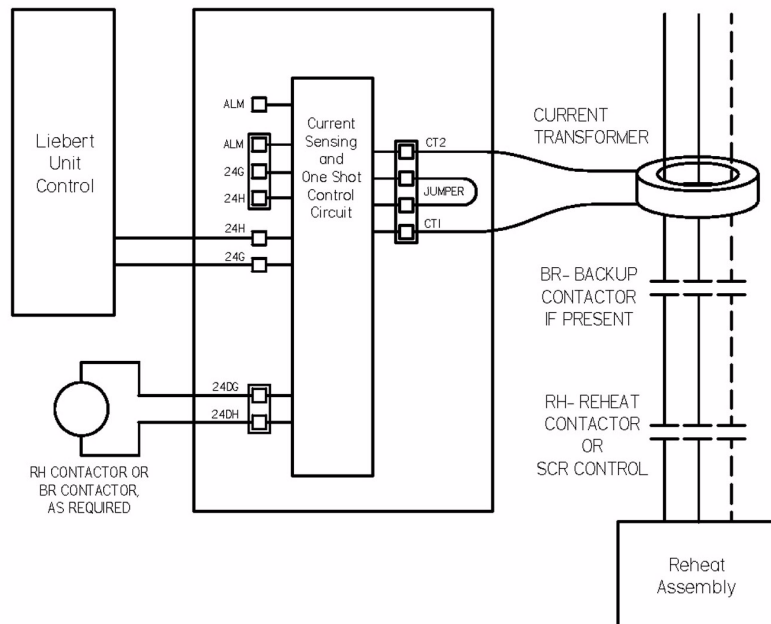
#### 4.1.3 Heating Operation

##### Electric Heat or Hot Water

The reheat stage is **ACTIVATED** when the temperature control calculates a requirement of 100%. Conversely, the reheat is **DEACTIVATED** when the heat requirement is 50% less than the activation point.

##### Ground Current Detector (GCD)

A Ground Current Detector is factory-installed on all 1-ton through 3-ton Mini-Mate2 units with reheat. The GCD detects reheat leakage current and shuts down operation of the reheat. A steady green LED indicates that the reheat is operating properly. A red LED indicates that the reheat has failed and both the reheat element and GCD need to be replaced.



#### WARNING

**DO NOT REMOVE OR DISABLE THE GROUND CURRENT DETECTOR. FAILURE TO LEAVE THE GCD IN PLACE COULD RESULT IN SMOKE OR FIRE.**

---

## SCR Electric Reheat

The SCR (Silicon Controlled Rectifier) controller proportionally controls the stainless steel reheat feature to maintain the selected room temperature. The rapid cycling made possible by the SCR controller provides precise temperature control, while the constant element temperature improves heater life. During operation of the SCR control, THE COMPRESSOR OPERATES CONTINUOUSLY. The heaters are modulated to provide temperature control. The display status will show when the unit is cooling and heating. The control will automatically lock the compressor cooling in the “ON” position, except when the temperature falls below the low temperature alarm setpoint. Cooling will then be disabled until the room temperature reaches this minimum temperature setpoint.

## 4.2 Humidity Control

### 4.2.1 Dehumidification/Humidification Required

The humidity control is based on a calculated percentage requirement for dehumidification or humidification (i.e., the difference between the return air humidity and the humidity setpoint). As the return air humidity rises above the humidity setpoint, the percent dehumidification required increases proportionally from 0% to 100% over a humidity band equal to the humidity sensitivity setting. The converse is true for percent humidification requirement.

### 4.2.2 Dehumidification Operation, Compressorized Direct Expansion (DX) Systems

Dehumidification with the standard configuration is accomplished by operating the compressor without the hot gas bypass active. The fan will operate at low speed unless the cooling requirement reaches 100%. At that point, the low speed fan is disabled (unless manually overridden by the user) until the cooling requirement decreases to 0%. Dehumidification will also be disabled if the heating requirement exceeds 125%. It will be re-enabled when the heating requirement reaches 50%.

### 4.2.3 Humidification Operation

The canister humidifier is activated when the humidity control calculates a requirement of 100% humidification, and it is deactivated when the humidification requirement falls below 50%.

## 4.3 Load Control Features

The control system monitors the compressor and prevents it from turning on within a 3-minute period of being off. If this on-off-on cycle occurs too often (e.g., 10 times in a one-hour period), a Short Cycle Alarm will occur.

## 4.4 Communications

The control system uses a two-wire, RS-422 channel to communicate with Liebert Site Products via a proprietary protocol. A converter board (ECA2) is available to allow communications with a “dumb” terminal or a computer using RS-232 channel. More details are provided in the Site Products and ECA2 user manual.

The communications channel provides both monitoring and control options, including:

- TEMPERATURE/HUMIDITY: Current temperature and humidity readings.
- STATUS (%): Cooling/heating and humidify/dehumidify operating status.
- PRESENT ALARMS: Alarms currently activated.
- SETPOINTS:
  - Temperature Setpoint
  - Temperature Sensitivity
  - Humidity Setpoint
  - Humidity Sensitivity
  - High Temperature Alarm
  - Low Temperature Alarm
  - High Humidity Alarm
  - Low Humidity Alarm
- ON/OFF STATUS
- SILENCE ALARM

---

## 5.0 ALARMS

---

The microprocessor control system will audibly and visually signal all ENABLED Alarms (including two (2) custom alarms). These special alarms can be chosen from the optional alarm list and/or can have their own fully custom text. The custom alarm inputs are contact closures wired from terminal TB1-1 through a normally open contact to either TB1-2 (alarm 1) or TB1-3 (alarm 2). The alarms can be enabled/disabled (refer to **3.0 - Microprocessor Control**) and a time delay of 0-255 seconds can be set. The alarms can also be programmed to either sound the alarm & activate the common alarm relay OR to sound the alarm only

When a new alarm occurs, it is displayed on the screen and the audible alarm is activated. (If communicating with a Liebert Site Product, the alarm is also transmitted). The message “PRESS ALARM SILENCE” will prompt the operator to silence the alarm. After the alarm is silenced, the display will return to the Normal Status display. Alarms can be reviewed by selecting the “ACTIVE ALARMS” feature. The alarms can also be silenced through communications with a Liebert Site Products Unit.

Many alarms will reset automatically when the alarm condition is no longer represented and only after it has been acknowledged by being ‘Silenced.’ The exceptions are: (1.) software alarms, i.e., Loss of Power and Short Cycle alarms will reset automatically 30 seconds after being silenced or acknowledged; and (2.) specific alarms monitoring overload or high pressure switches may require a manual reset depending upon the model.

### 5.1 Alarms: Definitions and Troubleshooting

The following list provides a definition and troubleshooting suggestions for each type of alarm. Refer to **8.0 - Troubleshooting** for additional details. If you need further assistance, contact your Liebert supplier. THE CUSTOMER MUST SPECIFY ALARM(S) AT THE TIME OF ORDER. OTHER DEVICES AND WIRING MAY BE REQUIRED AT THE FACTORY FOR SOME OF THE ALARMS.

#### 5.1.1 Custom Alarms

Custom alarm(s) messages are programmed at the LCD display. The message displayed may be included in a list of provided alarms or it may be customized text (for up to 2 alarms). IF CUSTOMIZED TEXT IS USED, MAINTENANCE PERSONNEL SHOULD BE INFORMED OF THE ALARM FUNCTION AND THE REQUIRED ACTION.

#### 5.1.2 High Head Pressure

Compressor head pressure is monitored with a pressure-sensor switch. (One SPDT pressure switch is used). If head pressure exceeds 360 PSIG, the switch turns off the compressor contactor and sends an input signal to the control. The condition is acknowledged by pressing the alarm silence button on the wall box, which will clear if the head pressure is alleviated. If the head pressure alarm has activated three times, the alarm will lock until the unit is serviced. After the head-pressure problem is fixed, reset the control by disconnecting power to the evaporator unit.

#### Air Cooled Systems

Check for power shut off to the condenser, condenser fans not working, defective head pressure control valves, dirty condenser coils or crimped lines.

#### Water/Glycol/ Systems

Check water regulating valves. Verify water/glycol flow (i.e., pumps operating and service valves open). Is water tower or drycooler operating? Is the coolant temperature entering the condenser at or below design conditions? Is AUX relay (terminals 70 & 71) operating during cooling to turn on the drycooler?

---

### 5.1.3 Humidity Level

The humidity level alarm may be activated under the following conditions:

- **High:** The room return air humidity exceeds the pre-set high humidity alarm set point. Is the unit set up for dehumidification? Check DIP switch.
- **Low:** The room return air humidity decreases to the high humidity alarm set point. Is the unit setup for humidification? Check DIP switch.
- **High and Low Simultaneously:** simultaneous display of two alarms results in loss of the humidity input signal. DASHES WILL BE DISPLAYED IN THE HUMIDITY READING DISPLAY. Under these conditions, the control system deactivates both humidification and dehumidification. Check for a disconnected cable or failed sensor.

### 5.1.4 Temperature

The temperature level alarm may be activated under the following conditions:

- **High:** room return air temperature increases to the high temperature alarm set point. Check for proper set point value. Is the room load more than the unit can handle (i.e., capacity too small)? Make sure cooling components are operating (compressor or valves).
- **Low:** The room return air temperature decreases to the low temperature alarm set point. Check for proper set point value. Make sure all heating components are operating (e.g., contactors, reheats, etc.). Are reheats drawing the proper current (refer to amp rating on name-plate)?
- **High and Low Simultaneously:** The simultaneous display of these two alarms results in loss of the temperature input signal (or the humidity is out of sensor range-15 to 85% RH). Dashes will be displayed for the temperature reading. The control system will initiate 100% cooling. Check for a disconnected cable or a failed sensor.



#### NOTE

*Check for proper set points. Does the room have a vapor barrier to seal it from outdoor humidity? Are doors or windows open to outside air?*

### 5.1.5 Humidifier Problem Alarm

The Humidifier Problem Alarm will sound and display a message if any of the following humidifier conditions occur: overcurrent detection; fill system fault or end of cylinder life.

### 5.1.6 High Water Alarm

A float switch in the evaporator pan will shutdown the evaporator on a high water level. Clear the drain and reset power to the unit in order to clear the alarm.

**Loss of Power.** The Loss of Power Alarm will activate (after power is restored to the unit) if the unit has lost power or the disconnect switch was incorrectly turned off before the unit ON switch was pressed. A Liebert remote monitoring unit (optional) will immediately indicate loss of power.

### 5.1.7 Short Cycle

A Short Cycle Alarm will occur if the compressor system has exceeded 10 cooling start attempts in a one-hour period. This can be caused by low refrigerant level or room cooling load is small compared to capacity of the unit. Check for leaks, crimped lines, and defective components. If room load is low, increase sensitivity to reduce cycle.

## 5.2 Optional/Custom Alarms

### 5.2.1 Loss of Water Flow

The Loss of Water Flow Alarm will occur if no water flow is detected in the chilled water or condenser water supply line. An external flow switch is required for this alarm. Check for service valves closed, pumps not working, etc.

---

## 5.2.2 Smoke Detected

Smoke is detected in the return air by an optional Liebert Smoke Detector. The evaporator unit will automatically shut down upon smoke detection. Locate source of smoke and follow appropriate emergency procedures.

---

## 6.0 SYSTEM TESTING AND MAINTENANCE

---

This section describes system testing, maintenance and replacement procedures. Use copies of the Maintenance Inspection Checklist to record preventive maintenance inspections.



### WARNING

**UNIT CONTAINS HAZARDOUS ELECTRICAL VOLTAGE.  
DISCONNECT POWER SUPPLY BEFORE WORKING WITHIN.  
LINE SIDE OF FACTORY DISCONNECT REMAINS ENERGIZED  
WHEN DISCONNECT IS OFF.**

### 6.1 System Testing

#### 6.1.1 Environmental Control Functions

The performance of all control circuits can be tested by changing the set points, which actuates each of the main functions.

#### 6.1.2 Cooling

To test the cooling function, set the set point to a temperature of 10°F (5°C) below room temperature. A call for cooling should register and prompt the equipment to begin cooling cycle. (Disregard any temperature alarms). Upon completion of testing, return set point to the desired temperature.

#### 6.1.3 Heating

Reheat may be tested by setting the set point for 10°F (5°C) above room temperature. A call for heating should register and prompt the equipment to begin heating cycle. (Disregard any temperature alarms). Upon completion of testing, return set point to the desired temperature.

#### 6.1.4 Humidification

To check humidification, set the humidity set point at R.H. 10% above the room humidity reading. After a short delay, the canister will fill with water and steam will be produced. Upon completion of testing, return the humidity set point to the desired humidity.

#### 6.1.5 Dehumidification

The dehumidification performance can be tested by setting the humidity set point at R.H. 10% below room relative humidity. The compressor should turn on and the fan should switch to low speed. Upon completion of testing, return humidity set point to the desired humidity.

#### 6.1.6 Firestat (Optional)

The optional firestat feature is a bi-metal operated sensing device with a closed switch under normal conditions. Connected between pins 1-8 and 1-9, this device will shut down the entire unit when the inlet air temperature exceeds a preset point.

#### 6.1.7 Smoke Detector

While the smoke detector is located in the unit, the optional smoke detector power supply is located in the electric panel. It constantly samples return air through a tube. No adjustments are required.

#### 6.1.8 Remote Shutdown

A connection point is provided for remote shutdown devices supplied by the customer. This terminal strip is located on the printed circuit board. (Terminals TB1-4 and TB1-5 are fitted with a jumper when no remote shutdown device is installed).



---

## 6.2 Maintenance

### 6.2.1 Electric Panel

The electric panel should be inspected on a semi-annual basis for any loose electrical connections.

### 6.2.2 Filters

Experience shows that filters are usually the most neglected item in an environmental control system. In order to maintain efficient operation, they should be checked monthly and changed as required. ALWAYS TURN POWER OFF BEFORE REPLACING FILTERS.

Filters can be replaced by either opening the hinged door on the return air filter box or by opening the return air grille (grille version only). Replacement filters are commercially available in several efficiencies, refer to the Technical Data Manual for appropriate filter sizes.

### 6.2.3 Direct Drive Blower Package

Monthly inspection of the blower package include: motor mounts, fan bearings, and impellers.

**Fan Impellers and Motor Bearings.** Fan impellers should be thoroughly inspected and any debris removed. Check to see if they are tightly mounted on the fan shaft and do not rub against the fan housing during rotation. Although the unit's motor bearings are permanently sealed and self-lubricating, they should be inspected monthly for signs of wear.

**Air Distribution.** Since all unit models are designed for constant volume air delivery, any unusual restrictions within the air circuit must be avoided. Note that high efficiency filters can reduce air performance and evaporator capacity.

**Motor Replacement.** If the evaporator motor needs to be replaced, first remove the air distribution plate on the bottom of the unit. Removing the mounting screws, allows the entire blower wheel and motor to be lifted out.

### 6.2.4 Refrigeration System

Each month the components of the refrigeration system should be inspected for proper function and signs of wear. Since in most cases evidence of malfunction is present prior to component failure, periodic inspections can be a major factor in the prevention of most system failures. Refrigerant lines must be properly supported and not allowed to vibrate against ceilings, floors, or the unit frame. Inspect all refrigerant lines every six months for signs of wear and proper support. Inspect the capillary and equalizer lines from the expansion valve.

**Suction Pressure.** Suction pressure will vary with load conditions. Suction pressure normally ranges from 58 psi to 75 psi (405 kPa to 517 kPa).

**Discharge Pressure.** The discharge pressure will vary greatly with load and ambient conditions (Table 18). The high-pressure switch will shut the compressor down at its cut-out setting.

**Table 18 Typical Discharge Pressures**

System Design	Discharge Psig	Pressure (kPa)
Air Cooled	180-275	(1242-1895)
Water Cooled 65 to 85°F water (18 to 29.4°C)	200-225	(1380-1550)
Glycol Cooled	210-275	(1445-1895)
Maximum	330	(2275)
High Pressure Cut-Out	360	(2480)

**Thermostatic Expansion Valve.** The thermostatic expansion valve keeps the evaporator supplied with enough refrigerant to satisfy load conditions. Proper valve operation can be determined by measuring superheat level. If too little refrigerant is being fed to the evaporator, then the superheat will be high. Conversely, if too much refrigerant is being supplied, then the superheat will be low. The correct superheat setting is between 10 and 15°F (5.6 and 8.3°C).

---

**Air Cooled Condenser.** Restricted airflow through the condenser coil will reduce the operating efficiency of the unit. Additionally, it can result in high compressor head pressure and loss of cooling. Using compressed air or commercial coil cleaner, clean the condenser coil of all debris that will inhibit airflow. In winter, do not permit snow to accumulate around the side or underneath the condenser. At the same time check for bent or damaged coil fins and repair as necessary. Check all refrigerant lines and capillaries for vibration and support as necessary. Carefully inspect all refrigerant lines for signs of oil leaks.

**Coaxial Condensers (Water/Glycol Cooled Condensers only).** Each water or glycol-cooled module has a coaxial condenser consisting of an exterior steel tube and an interior copper tube. If the water supply is clean, coaxial condensers do not normally require maintenance or replacement. Should your system begin to operate at high head pressure with reduced capacity, and all other causes have been eliminated, the condenser may be obstructed or fouled and should be cleaned or replaced.

**Regulating Valves.** The water regulating valve automatically regulate the amount of fluid necessary to remove the heat from the refrigeration system, permitting more fluid to flow when load conditions are high and less fluid to flow when load conditions are low. The valve consists of a brass body, balance spring, valve seat, valve disc holders, capillary tube to discharge pressure and adjusting screw.

The water regulating valve is designed to begin opening at 180 psi (1240 kpa) and be fully opened at 240 psi (1655 kpa). The valve is factory set and should not need adjustment. There is significant difference in the way standard pressure and high pressure valves are adjusted. Consult Liebert Service.

**Glycol Solution Maintenance.** It is difficult to establish a specific schedule of inhibitor maintenance since the rate of inhibitor depletion depends upon local water conditions. Analysis of water samples at time of installation and every six (6) months should help to establish a pattern of depletion. A visual inspection of the solution and filter residue is often helpful in judging whether or not active corrosion is occurring. The complexity of problems caused by water requires expert advice from a water treatment specialist plus a regular maintenance program schedule. It is important to note that improper use of water treatment chemicals can cause more severe problems than simply using none.

Proper inhibitor maintenance must be performed in order to prevent corrosion of the glycol system.

Consult your glycol manufacturer for proper testing and maintenance procedures. Do not mix products from different manufacturers.

**Hot Gas Bypass (Optional).** *Operation:* When applying hot gas bypass with split system condensing units, bypassing discharge gas to the compressor suction line offers more flexibility than conventional hot gas bypass to the evaporator unit.

The hot gas bypass valve is installed between the compressor discharge piping and suction piping, bypassing the condenser and evaporator coils. The discharge gas mixes with the suction gas, raising the suction temperature and pressure and decreasing the mass flow through the evaporator. The higher suction temperatures could cause compressor overheating, therefore a separate liquid quenching valve is provided to mix refrigerant from the system liquid line with the discharge gas before mixing with the suction gas entering the compressor.

During normal operation, when the evaporator is under full load the hot gas bypass equalizer pressure will remain high enough to keep the valve port closed. If the evaporator load decreases, the evaporator temperature and pressure will drop. When the suction pressure reduces below the hot gas bypass valve setting the hot gas bypass valve opens diverting some of the refrigerant flow back to the compressor suction. The liquid quenching valve bulb senses this increased superheat and opens, allowing liquid refrigerant to mix with the discharge gas, desuperheating it.

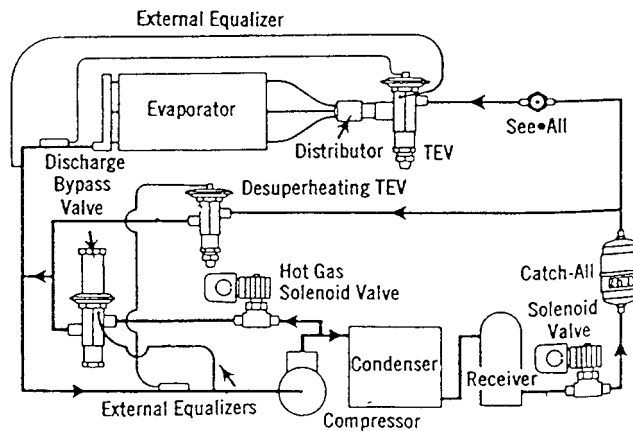
Proper mixing of the three refrigerant paths ensures stable operation and system performance. The liquid quenching valve bulb must be located downstream of all these connections to control superheat at the compressor inlet. Superheat settings for the liquid quenching valve are chosen to maintain consistency with the system expansion valve. During hot gas bypass operation higher

superheats, 50-60°F (19 to 15°C), may be observed at the compressor. The liquid quenching valve is internally equalized and superheat is not adjustable.

*Adjustment:*

1. Install the suction and discharge pressure gauge.
2. Adjust temperature setpoint to call for cooling so that the refrigeration compressor will run continuously.
3. Remove the TOP adjusting nut from the valve.
4. Insert an Allen wrench in the brass hole at top of valve in adjusting port, and turn CLOCKWISE if a higher evaporator temperature is required. Adjust no more than 1/4 turn at a time. Let the system stabilize for 15 minutes before determining if additional adjustment are necessary.
5. After obtaining the suction pressure required, reinstall cap tightly making sure there are no leaks.
6. Let the evaporator operate for approximately 10 to 15 minutes to make sure the suction pressure is within the range desired.
7. There may be a fluctuation of approximately 3 to 6 PSIG (21 to 41 kPa) on the evaporator due to the differential on the hot gas bypass.
8. Return temperature setpoint to the desired setting.

**Figure 16 Hot Gas Bypass**



### 6.3 Replacement Procedures

**Compressor Replacement.** Infrequently a fault in the motor insulation may result in a motor burnout (if system is properly installed, motor burnout rarely occurs). Primarily this type of failure is due to mechanical or lubrication problems, where the burnout is a secondary consequence.

Early detection can prevent a large percentage of the problems that can cause compressor failures. Periodic maintenance inspections by alert service personnel (i.e., identification of abnormal operation) can be a major factor in reducing maintenance costs. It is easier and more cost-effective to implement the necessary preventative steps that ensure proper system operation; rather than

---

ignore a problem until it results in compressor failure and costly replacement. When troubleshooting a compressor problem, check all electrical components for proper operation:



**CAUTION**

**Avoid touching or contacting the gas and oils with exposed skin. Severe burns will result. Use long rubber gloves in handling contaminated parts.**



**CAUTION**

**Do not loosen any refrigeration or electrical connections before relieving pressure.**

- Check all fuses and circuit breakers.
- Check pressure switch operation.
- If a compressor failure has occurred, determine whether its cause is an electrical or mechanical problem.

**Mechanical Failure.** If you have determined that a mechanical failure has occurred, the compressor must be replaced. If a burnout occurs, correct the problem and clean the system. It is important to note that successive burnouts OF THE SAME SYSTEM are usually caused by improper cleaning. If a severe burnout has occurred, the oil will be black and acidic.

**Electrical Failure.** In the event of an electrical failure and subsequent burnout of the refrigeration compressor motor, proper procedures must be followed to thoroughly remove any acids that would cause a future failure. There are two kits that can be used with a complete compressor burnout - Sporlan System Cleaner and Alco Dri-Kleener. Follow the manufacturer's procedure. **DAMAGE TO A REPLACEMENT COMPRESSOR DUE TO IMPROPER SYSTEM CLEANING CONSTITUTES ABUSE UNDER THE TERMS OF THE WARRANTY, THEREBY VOIDING THE WARRANTY.**

Replacement compressors are available from your Liebert supplier and will be shipped to the job site in a reusable crate (as required by the service contractor). If the compressor is under warranty, it must be returned to Liebert, in order to receive proper warranty credit. It should be returned in the same container it was shipped in. The possible cause(s) or condition(s) of the damage should be legibly recorded on the provided return tag.

Proper procedures to remove and replace the failed compressor are:

1. Disconnect power
2. Attach suction and discharge gauges to access fittings.
3. Recover refrigerant using standard recovery procedures and equipment. Use a filter-drier when charging the system with recovered refrigerant.



**NOTE**

*Release of refrigerant to the atmosphere is harmful to the environment and unlawful. Refrigerant must be recycled or discarded in accordance with federal, state and local regulations.*

4. Remove failed compressor.
5. Install replacement compressor and make all connections. Pressurize and leak test the system at approximately 150 PSIG (1034kPa) pressure.
6. Follow manufacturer's instructions for clean out kits.
7. Evacuate the system twice to 1500 microns, and the third time to 500 microns. Break the vacuum each time with clean, dry refrigerant to 2 PSIG (13.8 kPa).
8. Charge the system with refrigerant (R-22) based on requirements of the evaporator, condensing unit, and lines. Refer to the installation manual or the unit nameplate.
9. Apply power and operate the system. Check for proper operation. Refer to **Table 18 - Typical Discharge Pressures** for discharge pressure.

---

### 6.3.1 Steam Generating Humidifier-Operation Procedures

Steam generating humidifiers operate efficiently over a wide range of water quality conditions and automatically adjust to changes in the conductivity of water. The system will automatically drain and refill to maintain an amperage set point and alert the operator when the humidifier canister needs to be replaced.

The humidifier RUN/DRAIN switch is located in the humidifier assembly. This switch should be in the RUN position when the humidifier is in normal operation, and in the DRAIN position when a manual drain sequence is required. The electronic control board for the humidifier is also located in the humidifier assembly. When the unit is energized, power is available to humidifier. Operations involves the following steps:

1. During start-up, when the humidity control calls for humidification, the fill valve will open, allowing water to enter the canister. When the water level reaches the electrodes, current flows and the water will begin to warm. The canister fills until the amperage reaches the set point and the fill valve closes. As the water warms, its conductivity increases and the current flow, in turn, rises. If the amperage reaches 115% of the normal operating amperage, the drain valve opens and flushes some of the water out of the canister. This reduces electrode contact with the water and lowers the current flow to the amperage set point. Boiling soon commences and the canister operates normally.
2. If the conductivity of the water is low, the canister fills and the water level reaches the canister full electrode before the amperage set point is reached. The humidifier stops filling to prevent overflow. Boiling should commence in time. As water is boiled off, the mineral concentration in the canister increases and current flow also increases. The canister eventually reaches full output and goes to normal operation. No drain is permitted until then.
3. When full output is reached the circuit board starts a time cycle which is factory set at 60 seconds. During this repeating time cycle, the fill valve will open periodically to replenish the water being boiled off and maintain a "steady state" output at the set point. The amperage variance will depend on the conductivity of the water.
4. After a period of time, the mineral concentration in the canister becomes too high. When this occurs, the water boils too quickly. As the water quickly boils off and less of the electrode is exposed, the current flow decreases. When the current crosses the low threshold point (factory set at 85%) before the end of the time cycle, the drain valve opens, draining the mineral laden water out and replacing it with fresh water. This lowers the mineral concentration and returns the canister to "steady state" operation and prolongs canister life. The frequency of drains depends on water conductivity.
5. Over a period of time, the electrode surface will become coated with a layer of insulating material, which causes a drop in current flow. As this happens, the water level in the canister will slowly rise exposing new electrode surface to the water to maintain normal output. Eventually, the steady state water level will reach the canister full electrode and indicate so by activating the canister full alarm. At this point, all of electrode surface has been used up and the canister should be replaced.
6. After the entire electrode surface has been coated, the output will slowly decrease. This allows for maintenance scheduling. During these last hours of electrode life, the mineral concentration can increase and arcing can occur. If the electrodes start to arc, turn off the humidifier immediately and replace the canister with the identical part.

#### Replacing the humidifier canister

The proper procedure to replace the humidifier canister is:

1. Turn off the humidifier by lowering the humidity set point below the ambient humidity level. Record the original set point.
2. Place the RUN/DRAIN switch in the DRAIN position to drain the water from the canister.
3. Return the RUN/DRAIN switch to the RUN position after the canister has drained.
4. Turn OFF the power at the main unit.
5. Remove the cover from the humidifier cabinet.
6. Locate the power wires to the steam canister. They are connected to the canister with 1/4" quick connects. Make note of the wiring configuration before removing any wires. Refer to

---

schematic on unit. Slide the rubber boot back to expose the connections. Remove the two (2) power wires and the canister full wire. Do not loosen the screws that secure the electrodes.



**WARNING**

**CANISTER AND STEAM HOSE MAY BE HOT? ALLOW TIME FOR THE HUMIDIFIER TO COOL BEFORE REPLACING PARTS.**

7. Loosen the steam outlet hose clamps and slide the steam hose away from the canister fitting. Release the canister clamp along the base of the canister.
8. Remove the canister.
9. Reverse previous steps to re-assemble humidifier, paying special attention to the following:
  - When replacing the wiring, connect the red wire from terminal #1 on the interface to the red tip terminal on the canister. Reconnect the power wires as before (#2 on the left and #1 on the right).
  - When replacing the canister, always check the fill and drain solenoids for proper operation.



**WARNING**

**HAZARDOUS VOLTAGE! USE EXTREME CAUTION. CIRCUIT BOARD ADJUSTMENT SHOULD BE PERFORMED BY QUALIFIED PERSONNEL ONLY.**

**POWER SHOULD BE DISCONNECTED PRIOR TO THE PROCEDURE.**

### 6.3.2 Humidifier Circuit Board Adjustments

The humidifier control board governs humidifier operation. There are three potentiometers mounted on the board and can be used to adjust for extreme water conductivity conditions.

POT2 controls the amperage at which the drain will energize and is clearly marked in percentages. This adjustment is factory set at 85%, which indicates that the unit will drain when the amperage falls off to 85% of the capacity set point. Raising the value increases the frequency of drain cycles. Lowering the value decreases the frequency of drain cycles.

The frequency should be increased for highly conductive water and decreased for less conductive water. If adjustment is necessary, and a change of three to four percent in either direction does not permit normal operation of the unit, consult your Liebert supplier.

The POT1 controls the duration of the drain cycle. This adjustment is factory set at 60 seconds and should not be readjusted without consulting your Liebert supplier.

The POT3 control is factory set at 100%. The maximum capacity of the system is factory set, subsequently no field adjustment is possible.

The DIP switch settings are used to set the capacity of the humidifier. If the humidifier is replaced in the field the DIP switches should be set to the required settings described below (Table 19).

Table 19 DIP switch Settings for Humidifier Control Board

Voltage	SW1	SW2	SW3	SW4	Amps
208/230	On	Off	On	Off	4.0
220/240	Off	Off	On	Off	3.7
277	Off	On	Off	Off	3.1

---

## 7.0 MAINTENANCE INSPECTION CHECKLIST

---

Make Photocopies of this form for your records

Date: \_\_\_\_\_ Prepared By: \_\_\_\_\_

Model #: \_\_\_\_\_ Serial Number: \_\_\_\_\_



### NOTE

*Reheat element sheaths and fins are manufactured with stainless steel. Regular inspections are necessary to assure proper cleanliness of the reheating element. Should inspection reveal corrosion particles on the reheating element or adjoining surfaces (including ducts and plenums), appropriate cleaning should be performed. Periodic reheating element replacement may be required to meet specific application requirements.*

### Monthly

#### Filters

- \_\_\_ 1. Check for restricted airflow
- \_\_\_ 2. Check for filter
- \_\_\_ 3. Wipe section clean

#### Fan Section

- \_\_\_ 1. Impellers free of debris
- \_\_\_ 2. Bearings in good condition

#### Humidifier

- \_\_\_ 1. Check canister for mineral deposits
- \_\_\_ 2. Check condition of electrodes
- \_\_\_ 3. All hoses and fittings tight
- \_\_\_ 4. Check water make-up valve for leaks

### Semi-Annually

#### Compressor Section

- \_\_\_ 1. Signs of oil leaks
- \_\_\_ 2. Vibration isolation

#### Air Cooled Condensing Unit (if applicable)

- \_\_\_ 1. Condenser coil clean
- \_\_\_ 2. Motor mount tight
- \_\_\_ 3. Bearings in good condition
- \_\_\_ 4. Refrigerant lines properly supported

#### Water or Glycol Cooled Condensing

- \_\_\_ 1. Water valve adjustment
- \_\_\_ 2. Water flow
- \_\_\_ 3. Water leaks

#### Electric Panel

- \_\_\_ 1. Check electrical connections
- \_\_\_ 2. Operational sequence

#### Refrigeration Cycle

- \_\_\_ 1. Suction pressure
- \_\_\_ 2. Head pressure
- \_\_\_ 3. Superheat
- \_\_\_ 4. Evaporator coil clean
- \_\_\_ 5. Insulation intact

#### Flood Back Head Pressure Control (if applicable)

- \_\_\_ 1. Check Refrigerant level

#### Glycol Pump (if applicable)

- \_\_\_ 1. Glycol leaks
- \_\_\_ 2. Pump operation
- \_\_\_ 3. Glycol solution
- \_\_\_ 4. pH level

### Notes:

Signature: \_\_\_\_\_

## 8.0 TROUBLESHOOTING



### WARNING

**HAZARDOUS VOLTAGE WILL BE PRESENT AT EVAPORATOR, CONDENSER, REHEAT, AND HUMIDIFIER, EVEN WITH THE UNIT TURNED OFF AT THE CONTROL PANEL. WITH POWER AND CONTROLS ENERGIZED, UNIT COULD BEGIN OPERATING AUTOMATICALLY AT ANY TIME. TO ISOLATE UNIT FOR MAINTENANCE, TURN OFF POWER AT DISCONNECT SWITCH. TURN OFF POWER TO UNIT AT DISCONNECT SWITCH, UNLESS YOU ARE PERFORMING TESTS THAT REQUIRE POWER.**

**Table 20 Troubleshooting**

Symptom	Possible Causes	Check or Remedy
Unit will not start	No power to unit	Check voltage at input terminal block.
	Control voltage circuit breaker (at transformer) open	Locate short and reset circuit breaker.
	Float switch relay has closed due to high water in the condensate pan.	Has rubber band been removed from float switch? Check drain and line. Access from bottom through discharge air grille. Power must be cycled at the disconnect to reset.
	Jumper not in place	Check terminal TB1-4 and TB1-5 for jumper or N/C contact. Check pins 1-8 and 1-9 for jumper, or N/C firestat contact. Check pins 5-4 and 5-5 for jumper or N/C smoke detector contact.
No cooling	"Cooling" is not displayed at the control panel.	Adjust TEMP control set point and sensitivity to require cooling.
	Short cycle prevention control.	Control software delays compressor 3 minutes cooling, from stop to start
	Compressor contactor not pulling in.	Check for 24 VAC $\pm$ 2 VAC at terminals P4-8 and P4-4. If voltage, check contactor. If no voltage at P4-8 and P4-4, check at terminals P2-3 and P2-8. If voltage, check freeze stat.
	Compressor high head pressure.	See below for cause.
	Plugged filter/drier.	Replace filter/drier.
	Low refrigerant charge.	Check pressure gauges. See <b>Table 5</b> and <b>Table 6</b> for recommended pressures. At low ambient temperatures, proper refrigerant charge is very important on units with Lee-Temp receivers.
Compressor high head pressure	Insufficient air flow across condenser coil	Remove debris from coil and air inlets.
	Water/Glycol Cooled only: No fluid flowing through condenser.	Check fluid supply to regulating valve. Adjust valve if necessary.
	Self Contained, Air- Cooled only: Condenser fan not operating	Check fan operation.



**Table 20 Troubleshooting**

Symptom	Possible Causes	Check or Remedy
Humidifier does not operate	DIP switch not set to enable humidifier option	See DIP switch settings <b>Table 15</b> .
	"HUMIDIFY" not displayed at control panel	Increase humidity control set point and sensitivity to require humidification.
	Defective board	Check voltage at P3-1 and P1-9 on interface board for 24 VAC $\pm$ 2 VAC. If no voltage, check wiring and/or replace board. Check wiring from control panel to board.
	Failed humidity sensor	Humidity display will indicate dashes. Check wiring from temperature/humidity board to the control board and from the wall box to the control board. Replace wallbox or temperature/humidity circuit board (if remote).
	No water flow	Make sure switch is in Run position. Check humidifier water supply (including filter screen) and check nylon overflow line if canister is full.
	Canister fill rate is not keeping up with the steam output	Check fill valve screen opening and capillary tube for obstructions. Check water supply pressure (minimum 10 PSIG).

**Table 20 Troubleshooting**

Symptom	Possible Causes	Check or Remedy
Reheat will not operate	DIP switch not set to enable reheat option	See DIP switch settings <b>Table 15</b> .
	"HEAT" not displayed at the control panel	Increase temperature set point to require heating.
	Reheat safety open, defective reheat contact or defective board	Check voltage at P2-1 and P1-9 on interface board for 24 VAC $\pm$ 2 VAC. If voltage, check reheat contactor and reheat safety. If no voltage, check wiring and/or replace board.
	Element is burned out	Turn off power. Check element continuity with Ohm meter.
Fan will not operate at low speed when selected from control panel.	Open wiring or failed board	Verify "LOW FAN" is displayed at the control panel. Check for 24 VAC $\pm$ 2 VAC at terminals P3-4 and P1-9. If no voltage, check wiring and/or replace interface board. Check fan relays.
Fan will not operate at low speed during dehumidification	Temperature requirement is too high.	Verify with display. Cooling requirement overrides Dehumidification.
Cooling cycle too short	Sensor response delay too short	Increase sensor response delay. See <b>3.1.9 - Calibrate Sensors</b> .
Display freezes and control pads do not respond	Static discharge	During period of low humidity, static electricity can cause the control program to freeze or display incorrect information. Although this is unlikely, the control can be reset by cycling power from the disconnect switch.
Condensate pump does not operate	Open or short circuit in wiring	Find open or short circuit and repair power to pump.
Continuous Cooling	Failed temperature sensor	Temperature display will indicate dashes. Check wiring from temperature/humidity board (remote sensors) to the control board or from control board to wallbox. Replace temperature/humidity circuit board (remote sensors) or wallbox.
Continuous Cooling Dehumidification Humidification	Shorted wiring or failed control board	Check wiring and/or replace control board.



# Ensuring The High Availability Of Mission-Critical Data And Applications.

Emerson Network Power, the global leader in enabling business-critical continuity, ensures network resiliency and adaptability through a family of technologies—including Liebert power and cooling technologies—that protect and support business-critical systems. Liebert solutions employ an adaptive architecture that responds to changes in criticality, density and capacity. Enterprises benefit from greater IT system availability, operational flexibility and reduced capital equipment and operating costs.



While every precaution has been taken to ensure the accuracy and completeness of this literature, Liebert Corporation assumes no responsibility and disclaims all liability for damages resulting from use of this information or for any errors or omissions.  
© 2007 Liebert Corporation  
All rights reserved throughout the world. Specifications subject to change without notice.  
® Liebert and the Liebert logo are registered trademarks of Liebert Corporation. All names referred to are trademarks or registered trademarks of their respective owners.

SL-10530\_REV02\_02-07

## Emerson Network Power.

The global leader in enabling *Business-Critical Continuity*.

- AC Power
- Embedded Computing
- Outside Plant
- Racks & Integrated Cabinets
- Connectivity
- Embedded Power
- Power Switching & Controls
- Services
- DC Power
- Monitoring
- Precision Cooling
- Surge Protection

## Technical Support / Service Web Site

www.liebert.com

### Monitoring

800-222-5877

monitoring@emersonnetworkpower.com

Outside the US: 614-841-6755

### Single-Phase UPS

800-222-5877

upstech@emersonnetworkpower.com

Outside the US: 614-841-6755

### Three-Phase UPS

800-543-2378

powertech@emersonnetworkpower.com

### Environmental Systems

800-543-2778

Outside the United States

614-888-0246

### Locations

#### United States

1050 Dearborn Drive

P.O. Box 29186

Columbus, OH 43229

#### Europe

Via Leonardo Da Vinci 8

Zona Industriale Tognana

35028 Piove Di Sacco (PD) Italy

+39 049 9719 111

Fax: +39 049 5841 257

#### Asia

7/F, Dah Sing Financial Centre

108 Gloucester Road, Wanchai

Hong Kong

852 2572220

Fax: 852 28029250