

**Thermo Scientific
Revco® CxF -40C and -86C Chest Freezers**

Operating Manual 7045808 Rev. 3



Visit us online to register your warranty
www.thermoscientific.com/labwarranty

Thermo
S C I E N T I F I C

Important installer and user information:

A redundant temperature sensing device has been included in this ULT freezer. This device is a type “T” thermocouple. For convenient access, the thermocouple (Figure 1-3) terminates in an interconnect jack (Figure 1-5) behind the base front cover. (May be located differently in chests. See Section 1.) It is strongly recommended that this thermocouple be attached to a redundant 24 hour 7 day monitoring system with alarm capabilities. Connecting the sensor to a monitoring and alarm system separate from the freezer provides the utmost in product safety, should integral system fail. ▲

Packing List

Part No.	Description	Qty
213F	Key	2
380520	Neoprene Cap	2
510016	1/4-20 x 5-1/2" Bolt	2
195763	Retaining Clip	1
370563	Remote Alarm Connector	1

-86C Models Covered

Catalog Number	Model	Cu. ft.	Voltage
ULT-390-10-A	5808	3	120/60
ULT-390-10-V	5809	3	230/50
ULT-1390-10-A	5815	12.7	120/60
ULT-1390-10-V	5812	12.7	230/50
ULT1390-10-D	5813	12.7	230/60
ULT-1790-10-A	5818	17	120/60
ULT-1790-10-V	5819	17	230/50
ULT-1790-10-D	5822	17	230/60
ULT-2090-10-A	5821	20	120/60
ULT-2090-10-V	5820	20	230/50
ULT-2090-10-D	5823	20	230/60

-40C Models Covered

Catalog Number	Model	Cu. ft.	Voltage
ULT350-10-A	5308	3	120/60
ULT350-10-V	5309	3	230/50
ULT1350-10-V	5313	12.7	230/50
ULT1350-10-A	5315	12.7	120/60
ULT1350-10-D	5312	12.7	230/60
ULT1750-10-A	5318	17	120/60
ULT1750-10-D	5319	17	230/60
ULT1750-10-V	5322	17	230/50
ULT2050-10-A	5321	20	120/60
ULT2050-10-D	5320	20	230/60
ULT2050-10-V	5323	20	230/50

MANUAL NUMBER 7045808

3	40286/FR-2805	7/1/15	New start relay - expl enclosure drawing and 8702 & 8722 elec schematics	ccs
2	31013/FR-2673	6/18/14	RoHS compliant washer on oil separator (expl base dwg, refrig schematics)	ccs
1	30775/30673/FR-2607	2/5/14	Intended use and battery check - pgs ii & 5-4	ccs
--	30369/FR-2548	9/20/13	Pressure change on charging	ccs
0	30151/FR-2541	9/20/13	Release 9 - hinge change	ccs
REV	ECR/ECN	DATE	DESCRIPTION	By



Important Read this instruction manual. Failure to read, understand and follow the instructions in this manual may result in damage to the unit, injury to operating personnel, and poor equipment performance. ▲

Caution All internal adjustments and maintenance must be performed by qualified service personnel. ▲

Material in this manual is for information purposes only. The contents and the product it describes are subject to change without notice. Thermo Fisher Scientific makes no representations or warranties with respect to this manual. In no event shall Thermo be held liable for any damages, direct or incidental, arising out of or related to the use of this manual.

Material in this manual is for information purposes only. The contents and the product it describes are subject to change without notice. VWR International makes no representations or warranties with respect to this manual. In no event shall VWR be held liable for any damages, direct or incidental, arising out of or related to the use of this manual.

The -40C and -86C freezers (see page i for model numbers) described in this manual are high performance units which can be used for research and in situations that directly support medical applications. When these products are used to support a medical application, it is an accessory to a medical device and is therefor considered as a medical device in its own right by the regulatory body (e.g. FDA).

This product is intended for use:

- as cold storage in research use
- as a medical device for diagnostic use (storage of samples not intended to be re-introduced to the human body).

Registration: This medical application is considered a Class I device by the FDA. This product is classified as product code - JRM, regulation number 862.2050 and is considered a Class I device, 510(K) exempt.

© 2013 Thermo Fisher Scientific. All rights reserved.



Important operating and/or maintenance instructions. Read the accompanying text carefully.



Potential electrical hazards. Only qualified persons should perform procedures associated with this symbol.



Equipment being maintained or serviced must be turned off and locked off to prevent possible injury.



Hot surface(s) present which may cause burns to unprotected skin, or to materials which may be damaged by elevated temperatures.



Marking of electrical and electronic equipment, which applies to electrical and electronic equipment falling under the Directive 2002/96/EC (WEEE) and the equipment that has been put on the market after 13 August 2005.



This product is required to comply with the European Union's Waste Electrical & Electronic Equipment (WEEE) Directive 2002/96/EC. It is marked with the WEEE symbol. Thermo Fisher Scientific has contracted with one or more recycling/disposal companies in each EU Member State European Country, and this product should be disposed of or recycled through them. Further information on Thermo's compliance with this directive, the recyclers in your country and information on Thermo Scientific products will be available at www.thermoscientific.com.

- ✓ Always use the proper protective equipment (clothing, gloves, goggles, etc.)
- ✓ Always dissipate extreme cold or heat and wear protective clothing.
- ✓ Always follow good hygiene practices.
- ✓ Each individual is responsible for his or her own safety.

Do You Need Information or Assistance on Thermo Scientific Products?

If you do, please contact us 8:00 a.m. to 6:00 p.m. (Eastern Time) at:

1-740-373-4763

1-800-438-4851

1-877-213-8051

<http://www.thermoscientific.com>

service.led.marietta@thermofisher.com

www.unitylabservices.com

Direct

Toll Free, U.S. and Canada

FAX

Internet Worldwide Web Home Page

Tech Support Email Address

Certified Service Web Page

Our **Sales Support** staff can provide information on pricing and give you quotations. We can take your order and provide delivery information on major equipment items or make arrangements to have your local sales representative contact you. Our products are listed on the Internet and we can be contacted through our Internet home page.

Our **Service Support** staff can supply technical information about proper setup, operation or troubleshooting of your equipment. We can fill your needs for spare or replacement parts or provide you with on-site service. We can also provide you with a quotation on our Extended Warranty for your Thermo Scientific products.

Whatever Thermo Scientific products you need or use, we will be happy to discuss your applications. If you are experiencing technical problems, working together, we will help you locate the problem and, chances are, correct it yourself...over the telephone without a service call.

When more extensive service is necessary, we will assist you with direct factory trained technicians or a qualified service organization for on-the-spot repair. If your service need is covered by the warranty, we will arrange for the unit to be repaired at our expense and to your satisfaction.

Regardless of your needs, our professional telephone technicians are available to assist you Monday through Friday from 8:00 a.m. to 6:00 p.m. Eastern Time. Please contact us by telephone or fax. If you wish to write, our mailing address is:

Thermo Fisher Scientific
401 Millcreek Road, Box 649
Marietta, OH 45750

International customers, please contact your local Thermo Scientific distributor.

Table of Contents

Section 1	Installation and Start-up	1-1
	Control Panel Keys, Display, Indicators	1-5
	Install Freezer	1-7
	Displays	1-7
	RS-232 Communications	1-8
	Install Wall Bumpers	1-8
	Choose Location	1-8
	Remote Alarm Contacts and Analog Output	1-9
	Connect Unit to Electrical Power	1-10
	Attach Power Cord	1-10
	Freezer Start-Up	1-11
	Set Operating Temperature	1-11
	Set Low Temperature Alarm	1-12
	Set High Temperature Alarm	1-12
	Access Code	1-13
	Run Mode	1-13
Section 2	Calibrate	2-1
	Calibrate Mode	2-1
	Calibrate Control Probe	2-1
Section 3	Configuration	3-1
	Low Alarm Test	3-1
	High Alarm Test	3-1
	BUS Battery Test	3-2
	System Battery Test	3-2
	Set Access Code	3-3
	Clear High Stage Alarm	3-3
	Display Temperature	3-3
	Back Up System Type	3-4
	RS485 Address	3-4
	Reset Excursion	3-4
	Warm Excursion	3-4
	Cold Excursion	3-4

Section 4	Alarms	4-1
	Lost Communication	4-2
	Micro Board Failure Alarm	4-2
	Multiple Alarms	4-2
	High Stage System Failure Alarm	4-2
Section 5	Maintenance	5-1
	Clean Air Filter	5-1
	Clean Condenser	5-1
	Defrost Chamber	5-2
	Prepare Unit for Storage	5-2
	Clean Lid Gasket	5-2
	Replace Battery(s)	5-3
	Check Battery(s)	5-4
	PREVENTIVE MAINTENANCE	5-5
Section 6	Factory Installed Options	6-1
	Back Up System (BUS)	6-1
	Install Injection Assembly	6-1
	Install Temperature Probe	6-2
	BUS Control Panel	6-4
	Connect Probe/Solenoid Harness	6-4
	Set Optional BUS Set Point	6-5
	Configure Optional Back Up System (BUS)	6-5
	Test the BUS	6-6
	Disconnect Fitting Assembly, Transfer Hose	6-6
	Chart Recorder	6-6
	Calibrate Chart Recorder	6-7
	Change Program	6-7
	Install Chart Paper	6-7
Section 7	Specifications	7-1
Section 8	Warranty Information	8-1
Appendix	Handling Liquid Nitrogen	A -1
	Handling Liquid CO₂	A -4
	First Aid	C - 1

Section 1 Installation and Start-up

Figures 1-1 and 1-2 show the front view of the freezer and indicate the following freezer components:

- Control Panel - keypad, displays and indicators.
- BUS (Optional Back Up System) panel.
- Optional temperature recorder (7 day, one pen) or datalogger.
- Keylock - keyed lid lock.

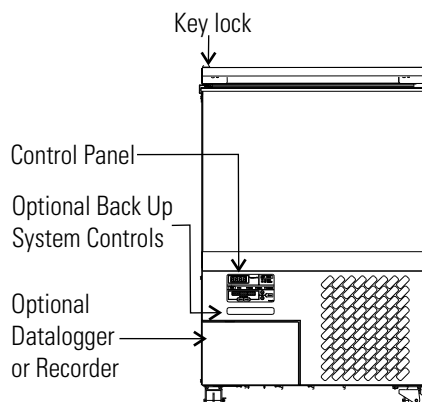

Figure 1-1. Front View 3 cu ft Models

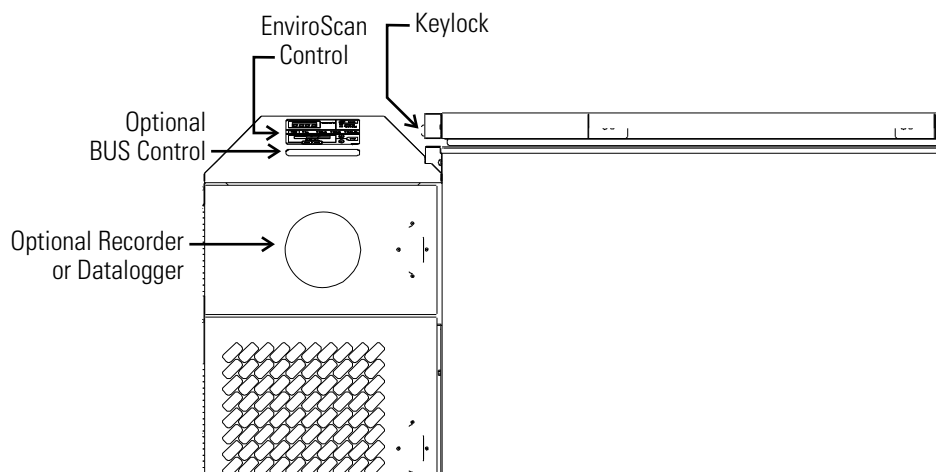

Figure 1-2. Front View Remaining Models

Figures 1-3 and 1-4 display the rear view of the freezer and indicate the following freezer components:

- Remote alarm contacts and selectable analog output connection - 0-1V, 4-20mA (default), 0-5V).
- Power inlet for power cord connection.
- Optional BUS connections for probe and solenoid.
- RS-232 or RS-485 interface.
- Power Switch (mains disconnect).

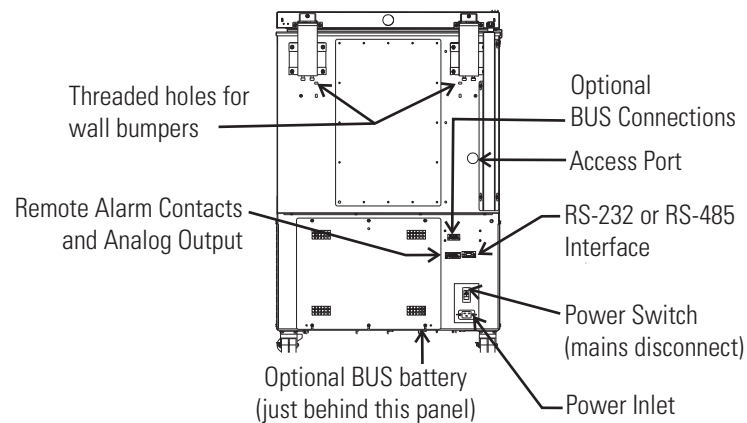

Figure 1-3. Rear View 3 cu ft Models

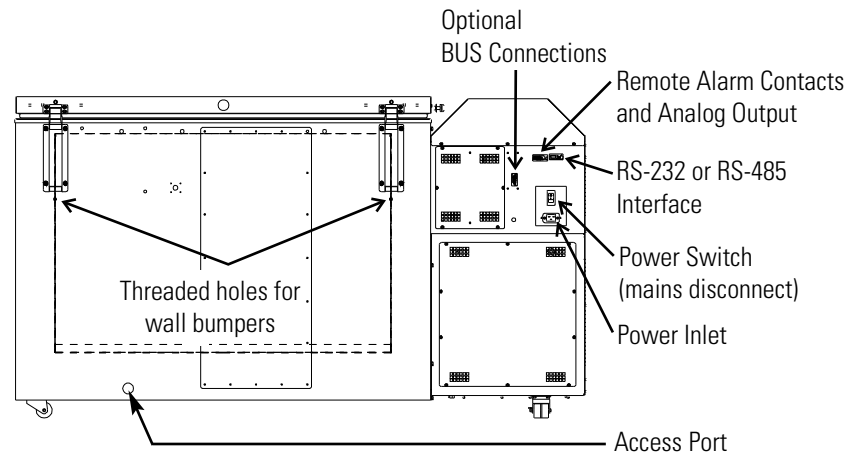

Figure 1-4. Rear View Remaining Models

The probe cover houses the control, optional recorder, datalogger, Model 1535 alarm, or BUS probes.

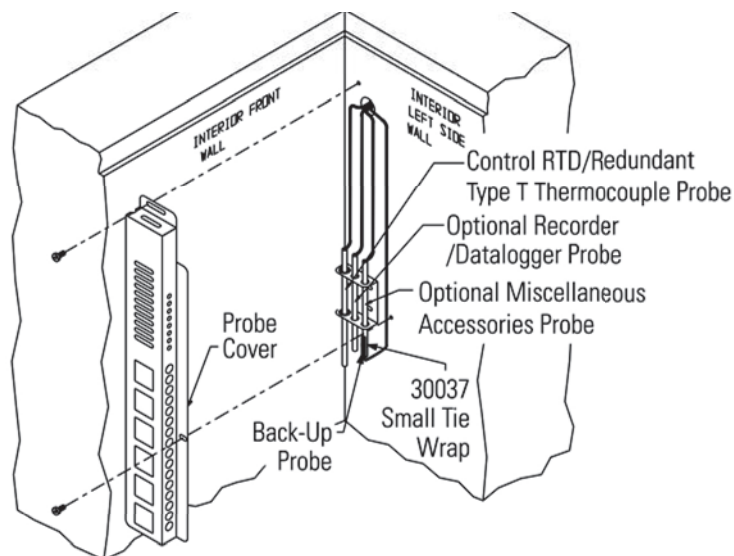

Figure 1-5. Probe Cover

Figures 1-6, 1-7, and 1-8 indicate the following components:

- Freezer filter location
- Battery power switch (freezer and BUS)
- Thermocouple receptacle
- Battery mounting bracket
- Freezer and optional BUS battery

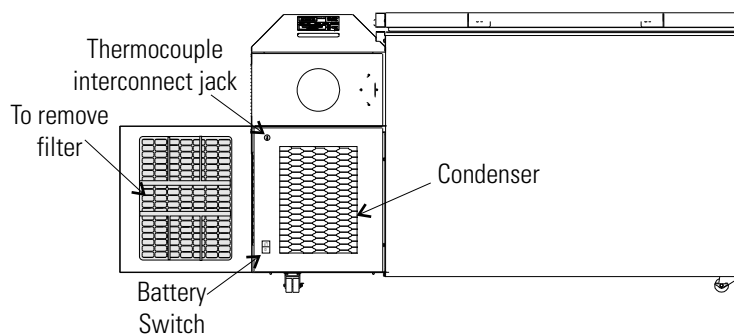

Figure 1-6. All Models Except 3 cu ft

Section 1
Installation and Start-up

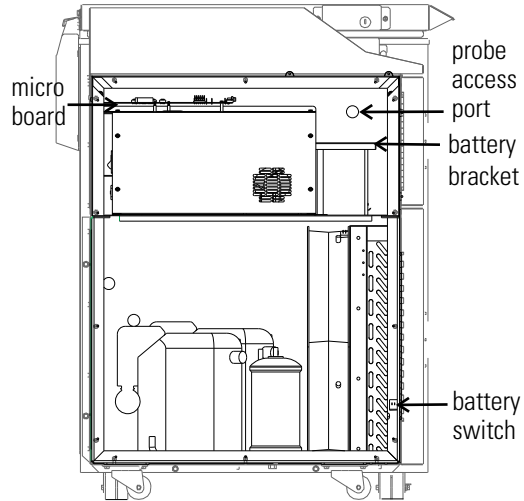

Figure 1-7. Freezer Left Side - Sidecar panel removed

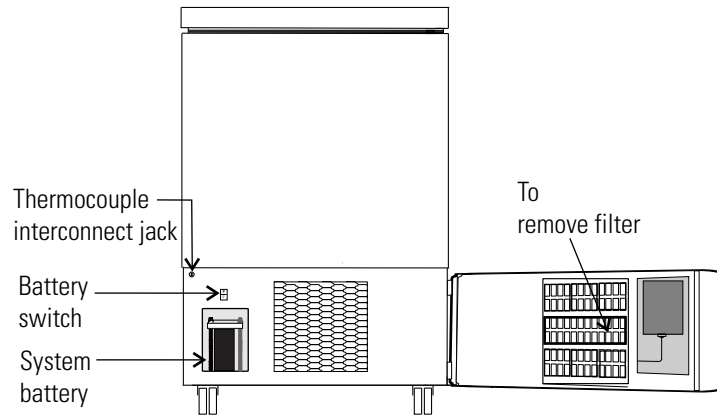

Figure 1-8. 3 cu ft Models

Control Panel Keys, Display, Indicators

Mode Select Switch - Used to select Run, Settings, Calibrate and System Configuration Modes.

Mode Select Indicators -

Run: Run Menu

Settings: Set Points Menu

Calibrate: Calibrate Menu

Configuration: Configuration Menu

Temperature Display - Displays temperature in degrees Celsius.

Alarm Indicator - Light pulses on/off during an alarm condition.

Silence - Mutes the audible alarm.

Low Battery - indicates a low battery condition of the freezer battery.

Hot Condenser - indicates a hot condenser condition.

Message Center - displays system status and alarms.

Scroll for Parameters Arrows - moves through the choices of the selected mode.

Up and Down Arrows - Increases or decreases values, toggles between choices.

Enter - Stores the value into computer memory.

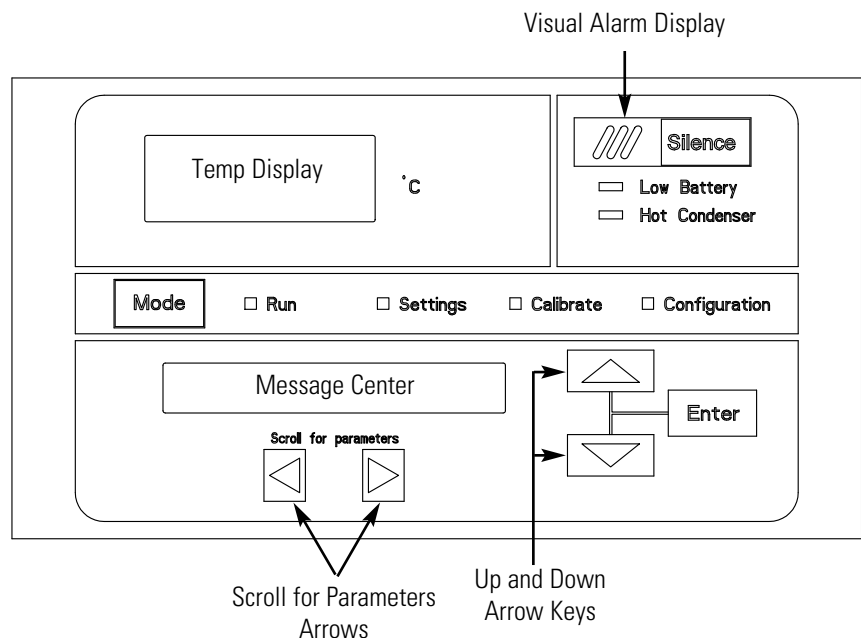

Figure 1-9. Control Panel Keys, Display and Indicators

Panel Keys, Display, Indicators (cont.)

Revco CxF freezers have four basic modes which allow freezer setup: Run, Settings, Calibrate and Configuration.

Run is the default mode which the freezer will normally be in during operation.

Settings is used to enter system set points for freezer operation.

Calibrate is used to calibrate various system parameters.

Configuration allows for custom setup of various options.

The chart below shows the selections under each of the modes.

Table 1-1. Modes of Operation

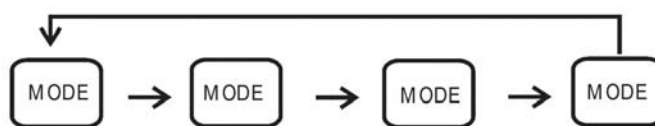

Run	Settings	Calibrate	Configuration
Default Mode System Ok	Control Set Point	Control Probe	High Alarm Test
Line Voltage	High Alarm Set Point	Optional Sample Probe	Low Alarm Test
Compensated Voltage	Low Alarm Set Point		System Battery Test
* HSHX Temperature	Optional Back Up System Set Point		BUS Battery Test
			Display Temperature
			* Clear High Stage Alarm
			Set Access Code
			RS485 Address
			BUS type CO2 or LN2
			Cold Excursion
			Warm Excursion
			Reset Excursion

* -86C units only

Panel Keys, Display, Indicators (cont.)

Scroll for Parameters Arrows: Steps the operator through the parameters of Settings, Calibrate and Configuration Modes. The right arrow goes to the next parameter, the left arrow returns to the previous parameter.

Up Arrow: Increases or toggles the parameter value that has been selected in the Settings, Calibrate, and Configuration Modes.

Enter: Must press Enter key to save to memory all changed values.

Down Arrow: Decreases or toggles the parameter values that have been selected in the Settings, Calibrate, and Configuration Modes.

Silence Key: Press to mute the audible alarm. See Section 4 for alarm ringback times.

Message Center: Displays the system status (Mode) at all times. Displays SYSTEM OK during normal operation, or alarm messages if the system detects an alarm condition. See Section 4 - Alarms.

Displays

There are two displays on the control panel. The temperature display shows the temperature in degrees Celsius. The message center displays the system status (Mode) at all times. The message SYSTEM OK displays during normal operation. Alarm messages are displayed if the system detects an alarm condition. See Section 4 - Alarms.

Install Freezer

To remove the freezer from the pallet, use a 7/16" wrench to remove all the bolts securing the shipping bracket to the pallet.

Note If tipped more than 45°, allow the unit to set upright for 24 hours before start up. ▲

Remove the shipping bracket. Remove the ramp boards from the pallet and place the slotted end over the ramp brackets on the pallet. The support blocks on the ramps will be facing down. Before moving the freezer, make sure the casters are unlocked and moving freely. Align the caster with the ramp boards. Use adequate personnel to roll the freezer off the pallet.

The freezer can be easily pushed to the desired approved location, as described previously. When the freezer is in position, set the front caster brakes.

Note Do not move the freezer with the product load inside. ▲

Choose Location

Locate the freezer on a firm, level surface in an area with an ambient temperature between 18°C and 32°C. Provide ample room to reach the mains disconnect switch (power switch) located on the rear of the freezer.

Note For proper ventilation and airflow, a minimum clearance of 5” at the rear and front and a clearance of 8” on the side of the freezer is required. Allow adequate space for lid opening. If ambient increases above 36°C, clearance at the rear of the cabinet must be increased to 8”. ▲

Install Wall Bumpers

The parts bag, located inside the cabinet, contains the following parts.

Quantity	Stock #	Description	Purpose
2	510016	1/4-20 x 5-1/2” Bolt	Wall Bumper
2	380520	Neoprene Cap	Cap Protector

Install the bolts into the pre-tapped holes on the back of the compressor section. Install a neoprene cap on each bolt. Refer to Figure 1-2 for the locations of the pre-tapped holes.

RS-232 Communications

Revco CxF freezers have a data communications interface. The factory default setting is RS-232.

The wiring identification for the interface is shown in Figure 1-10. One nine pin, sub "D" style connector is located on the back of the freezer. See Figure 1-2 for the location of the connector on the freezer.

Figure 1-10. RS-232 Interface

The freezer transmits temperature information every 60 minutes. A standard DB9 serial extension cable can be used to connect the freezer to a serial device. Some serial devices may require a null modem adapter.

Data format:

Baud1200
 Data bits8 (7 bit ASCII with leading zero)
 Start bits1
 Stop bits2
 Paritynone

Remote Alarm Contacts and Analog Output (cont.)

The analog output function allows the freezer to output signals representing the temperature of the freezer cabinet. The factory default setting is 4-20 mA. Refer to Table 1-2 for output specifications.

IMPORTANT USER INFORMATION

CAUTION! Stored product should be protected by a redundant 24 hour/day monitoring system with alarm capability. An interconnect jack and thermocouple are installed for centralized monitoring, should on-board system fail.

Table 1-2. Analog Output Specifications

	4-20 mA	0-1V	0-5V
Temperature	-100 to +50°C	-100 to +50°C	-100 to +50°C

Attach Power Cord

Insert the power cord into the power inlet module. Place the retaining bracket (P/N 195763) over the connector. Tighten retaining screws to secure.

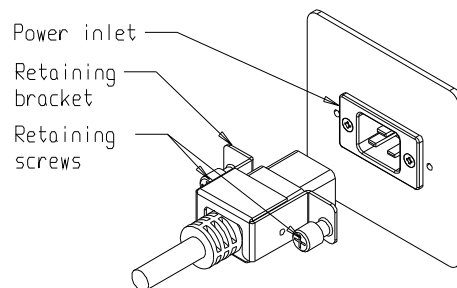

Figure 1-12. Power Cord Attachment

Connect Unit to Electrical Power

Note See the serial tag on the side of the unit for electrical specifications or refer to the electrical schematics in this manual. ▲

The freezer should be operated on a dedicated, grounded service. Check the voltage rating on the serial tag of the unit and compare it with the outlet voltage. Then, with the power switch turned off, plug the line cord into the wall outlet.

First, turn on the freezer power switch. Then open the lower front door by grasping the bottom left corner. Locate the battery switch (Figure 1-4) and turn it to Standby mode (⏻). During initial freezer start-up, the system battery may require charging and the Low Battery message may appear in the message center.

Note Ensure the battery switch is turned to Standby mode (⏻). The rechargeable batteries require 36 hours to charge at initial start-up. A “Low Battery” alarm may occur until the batteries are fully charged. Should a power failure occur during the initial start-up period, the electronics will have limited operation. ▲

Freezer Start-Up

With the freezer properly installed and connected to power, system set points can be entered. The following set points can be entered in Settings mode: Control temperature, high temperature alarm set point, low temperature alarm set point, and (optional) BUS set point. Default settings are shown in the table below. See Chart 1-1 for more detail.

-86C Units		-40C Units	
Control Set Point	-80°C	Control Set Point	-40°C
High Temperature Alarm	-70°C	High Temperature Alarm	-30°C
Low temperature alarm	-90°C	Low temperature alarm	-50°C
Optional BUS Set Point	-60°C	Optional BUS Set Point	-30°C

Note If the set point is changed and the low temperature and high temperature alarms are set 10° from the set point, the alarm set points will be adjusted automatically to maintain a distance of at least 10° from set point. ▲

Set Operating Temperature

The freezer has an operating temperature range of -50°C to -86°C (-86C units) or -10°C to -40°C (-40C units), depending on ambient temperature. The freezer is shipped from the factory with a temperature set point of -80°C (-86C units) or -40° (-40C units). To change the operating temperature set point:

1. Press the Mode key until the Settings indicator lights.
2. Press the right arrow until “SET PT = -XX” is displayed in the message center.
3. Press the up/down arrow key until the desired temperature set point is displayed.
4. Press Enter to save the set point.
5. Press the Mode key until the Run indicator lights for Run mode or press the right/left arrow keys to go to next/previous parameter.

If no control keys are pressed, the freezer will automatically return to RUN mode after 5 minutes.

Set High Temperature Alarm

The high temperature alarm activates an audible/visual warning when the freezer chamber temp reaches or exceeds the high temp alarm set point.

To set the high temperature alarm set point:

1. Press the Mode key until the Set indicator lights.
2. Press right arrow until “HI ALM = -XX” displays in message center.
3. Press the up or down arrow key until the desired high temperature alarm set point is displayed.
4. Press Enter to save the setting.
5. Press the Mode key until the Run indicator lights or press the right or left arrow to go to the next or previous parameter.

If no control keys are pressed, the freezer will automatically return to RUN mode after 5 minutes.

Note The high alarm set point must be set at least 5°C from the control set point. ▲

Note At initial start-up, the high temperature alarm is disabled until the cabinet reaches set point or 12 hours elapse. ▲

Set Low Temperature Alarm

The low temperature alarm activates an audible/visual warning when the freezer chamber temp reaches or decreases below low temp alarm set point.

To set the low temperature alarm set point:

1. Press the Mode key until the Settings indicator lights.
2. Press right arrow until “LO ALM = -XX” displays in message center.
3. Press the up or down arrow key until the desired low temperature alarm set point is displayed.
4. Press Enter to save the setting.
5. Press the Mode key until the Run indicator lights or press the right or left arrow to go to the next or previous parameter.

If no control keys are pressed, the freezer will automatically return to RUN mode after 5 minutes.

Note The low alarm set point must be set at least 5°C from the control set point. ▲

Access Code An access code can be set to prevent unauthorized change of settings in Calibrate, Configuration and Settings mode. (An access code of 000 is required to make changes.) If the access code is not at the default 000, you can not leave RUN mode without entering a code. See Section 3, Configuration for instructions on modifying the access code.

Run Mode Run mode is the default mode for the freezer. The run mode displays the cabinet temperature on the temperature display and 'SYSTEM OK' on the message center under normal operating conditions. In addition, the Run mode allows display of the following information:

LINE VOLTAGE

COMPENSATED VOLTAGE

* HSHX TEMPERATURE (heat exchanger temperature); -86C units only

This information is scrolled individually by pressing the right arrow key. In each case, the message center returns to SYSTEM OK in 10 seconds if no keys are pressed.

Chart 1-1

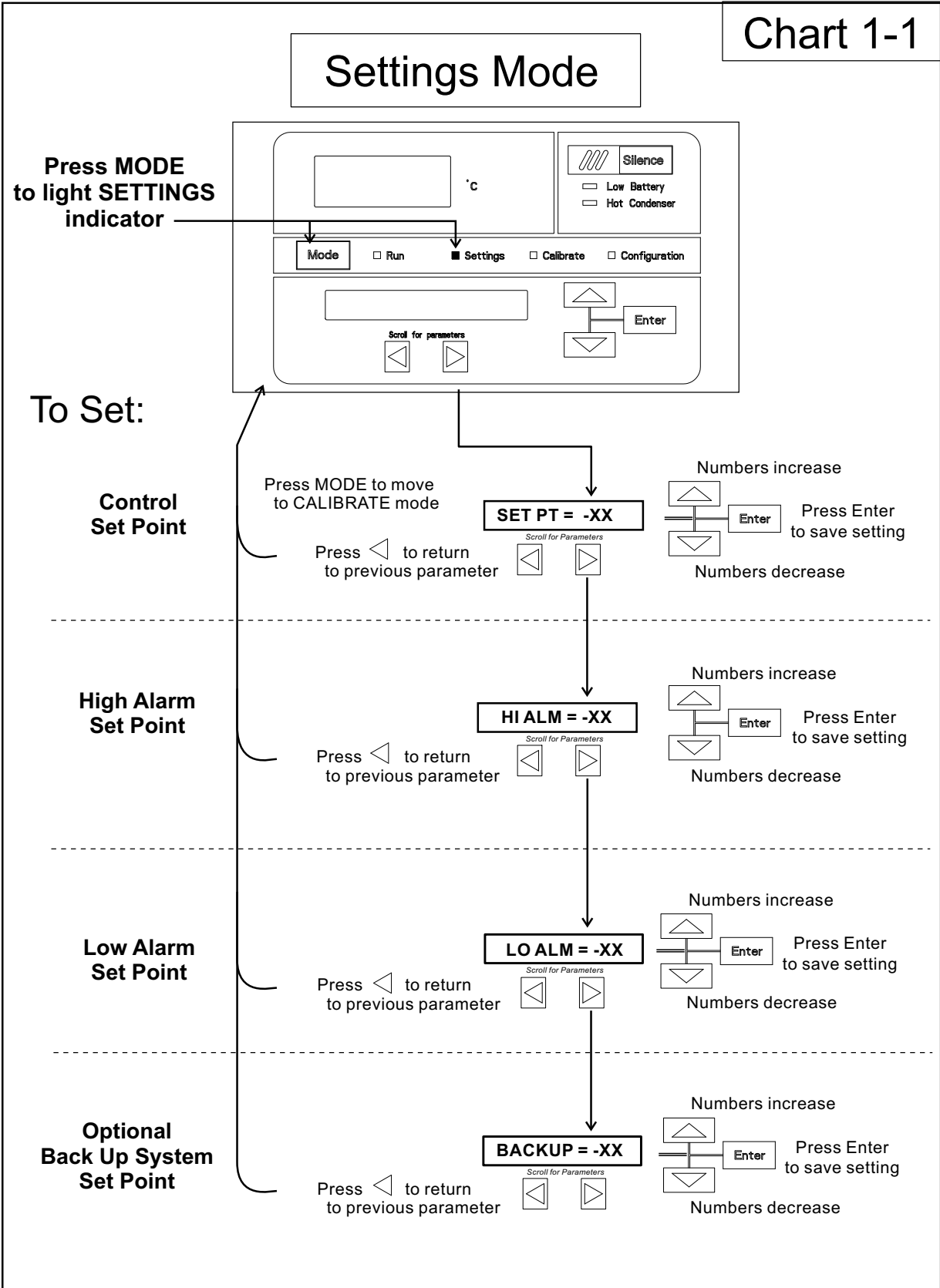

Section 2 Calibrate

Calibrate Mode

Once the freezer has stabilized, the control probe may need to be calibrated. Calibration frequency is dependent on use, ambient conditions and accuracy required. A good laboratory practice would require at least an annual calibration check. On new installations, all parameters should be checked after the stabilization period.

Note Before making any calibration or adjustments to the unit, it is imperative that all reference instruments be properly calibrated. ▲

Calibrate Control Probe

Plug a type T thermocouple reader into the receptacle located inside the lower door (see Figures 1-4 and 1-6). Compare the control temperature set point to the temperature of the measuring device. See Chart 2-1 at the end of this section for more detail.

1. Press the Mode key until the Calibrate indicator lights.
2. Press the right arrow until “CONT T = -XX.X” appears in the message center.
3. Press up/down arrow to match the display to calibrated instrument.
4. Press Enter to store calibration.
5. Press the Mode key to return to Run or the right/left arrow to go to next/previous parameter.

Temperature Stabilization Periods

Start-up - Allow 12 hours for the temperature in the cabinet to stabilize before proceeding.

Already Operating - Allow at least 2 hours after the display reaches set point for temperature to stabilize before proceeding.

Note During calibration, the temperature display will not be available.

If no keys are pressed for approximately five minutes while in calibration mode, the system will reset to Run mode.

Chart 2-1

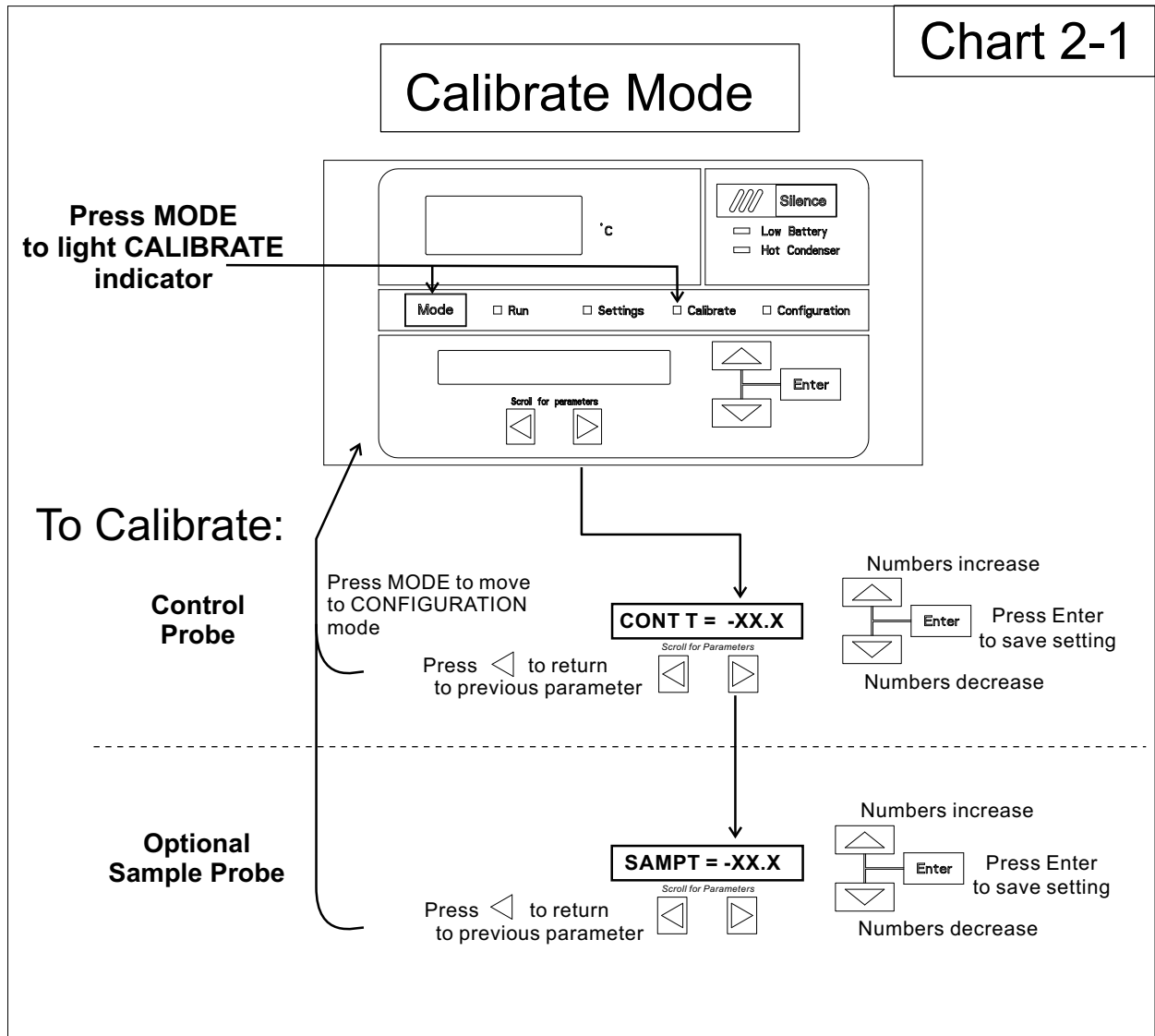

Section 3 Configuration

Configuration Mode is used for testing and custom setup of the freezer. The configuration functions listed and described below may not be necessary in all applications, but are available if needed. See Chart 3-1 for more detail.

High Alarm Test

The high alarm test is used to verify that the high alarm will activate, should the freezer temperature equal or exceed the high alarm set point.

1. Press the Mode key until the Configuration indicator lights.
2. Press the right arrow until HI ALRM TEST is displayed in the message center.
3. Press Enter to initiate the test.

The temperature on the display will begin to increase until the high alarm set point has been reached. The audible alarm will sound and the alarm indicator will flash. Press the Silence key to mute the alarm.

Low Alarm Test

The low alarm test is used to verify the that low alarm will activate, should the freezer temperature equal or become less than the low alarm set point.

1. Press the Mode key until the Configuration indicator lights.
2. Press the right arrow until LO ALRM TEST is displayed in the message center.
3. Press Enter to initiate the test.

The temperature on the display will begin to decrease until the low alarm set point has been reached. The audible alarm will sound and the alarm indicator will flash. Press the Silence key to mute the alarm.

System Battery Test

To test the charge of the freezer battery:

1. Press the Mode key until the Configuration indicator lights.
2. Press the right arrow until SYS BAT TEST is displayed in the message center.
3. Press Enter to initiate the test.

TESTING BATT will display during the testing period. Upon completion of the test the message center will display BATT GOOD or BATT FAIL. When a test is failed, the audible alarm will sound, the alarm indicator and the Low Battery indicator will light. Press the Silence key and the alarm indicator will go off. The Low Battery light will stay on until a future battery test is performed and passed.

BUS Battery Test

To test the charge of the BUS battery:

1. Press the Mode key until the Configuration indicator lights.
2. Press the right arrow until BUS BAT TEST is displayed in the message center.
3. Press Enter to initiate the test.

TESTING BATT will display during the testing period. Upon completion of the test the message center will display BBAT GOOD or BBAT FAIL. If this test fails, the audible alarm will sound, the alarm indicator and the Low Battery indicator will light. Press the Silence key. The audible alarm and alarm indicator will go off. The Low Battery light will stay on. If the test fails, it is recommended to replace the BUS battery.

Display Temperature

This function, only available on freezers with the optional sample probe, allows the user to select which temperature is displayed in the temperature display window. The options are CONTROL or SAMPLE.

1. Press the Mode key until the Configuration indicator lights.
2. Press the right arrow until DISP CONTROL or DISP SAMPLE is displayed in the message center.
3. Press up/down arrow to toggle between the two display selections.
4. Press Enter to save.

If control probe is selected, the temperature display will be on continuously. If sample probe is selected, the temperature display will be preceded with a letter 'S'.

Clear High Stage Alarm (-86C units only)

Should a high stage alarm have occurred, it may become necessary to clear the alarm condition after the condition has been corrected.

1. Press the Mode key until the Configuration indicator lights.
2. Press the right arrow until CLR HS ALARM is displayed in the message center.
3. Press Enter to clear the alarm.

Set Access Code

To set the Access Code:

1. Press the Mode key until the Configuration indicator lights.
2. Press the right arrow until "SET ACC CODE" is displayed in the message center.
3. Press Enter.
4. The message center will display ACC CODE = 000. Press the up or down arrow key until the desired access code is displayed (000 - 999). Press the left or right arrow key to select digit 1, 2, 3.

Note The left and right arrow keys are used to move from the first through the third digits within the access code. ▲

5. Press Enter to save the setting
6. Press the Mode key until the Run indicator lights. A 3-digit Access Code can be entered to avoid unauthorized personnel from changing the set points, calibration, or configuration. A setting of 000 will bypass the access code. The factory setting is 000.

RS485 Address

If the freezer is configured for RS-485 communications, it will need to have a unique identification address. This address is set through the Configuration mode.

1. Press the Mode key until the Configuration indicator lights.
2. Press the right arrow until RS485ADDR is displayed in the message center.
3. Press Enter. The message center will display 485 ADDR XX.
4. Press up/down arrow to select the appropriate address for the freezer (1 - 24).
5. Press Enter to save.

Back Up System Type

This function, which is only available on freezers with the optional back up system (BUS), allows the user to select which type of gas is injected into the freezer chamber. The options are CO₂ and LN₂.

1. Press the Mode key until the Configuration indicator lights.
2. Press the right arrow until BUS TYPE CO₂ or BUS TYPE LN₂ is displayed in the message center.
3. Press up/down arrow to toggle between the two display selections.
4. Press Enter to save.

Cold Excursion

This function displays the coldest temperature recorded by the control probe.

Warm Excursion

This function displays the warmest temperature recorded by the control probe.

Reset Excursion

This function resets the cold and warm excursions.

Chart 3-1

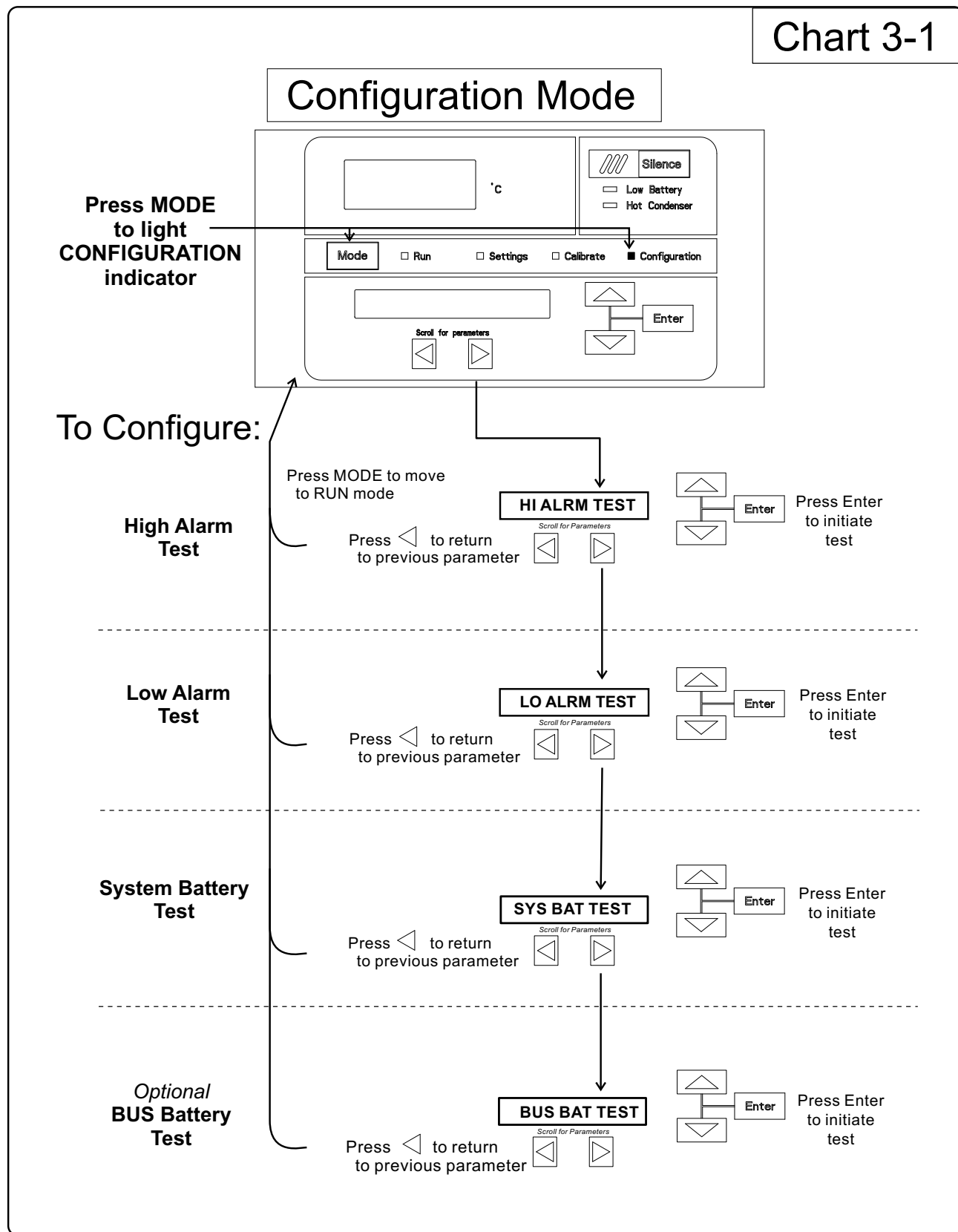

Configuration Mode, Chart 3-1, Page 2 of 3

refer to previous page

To Configure:

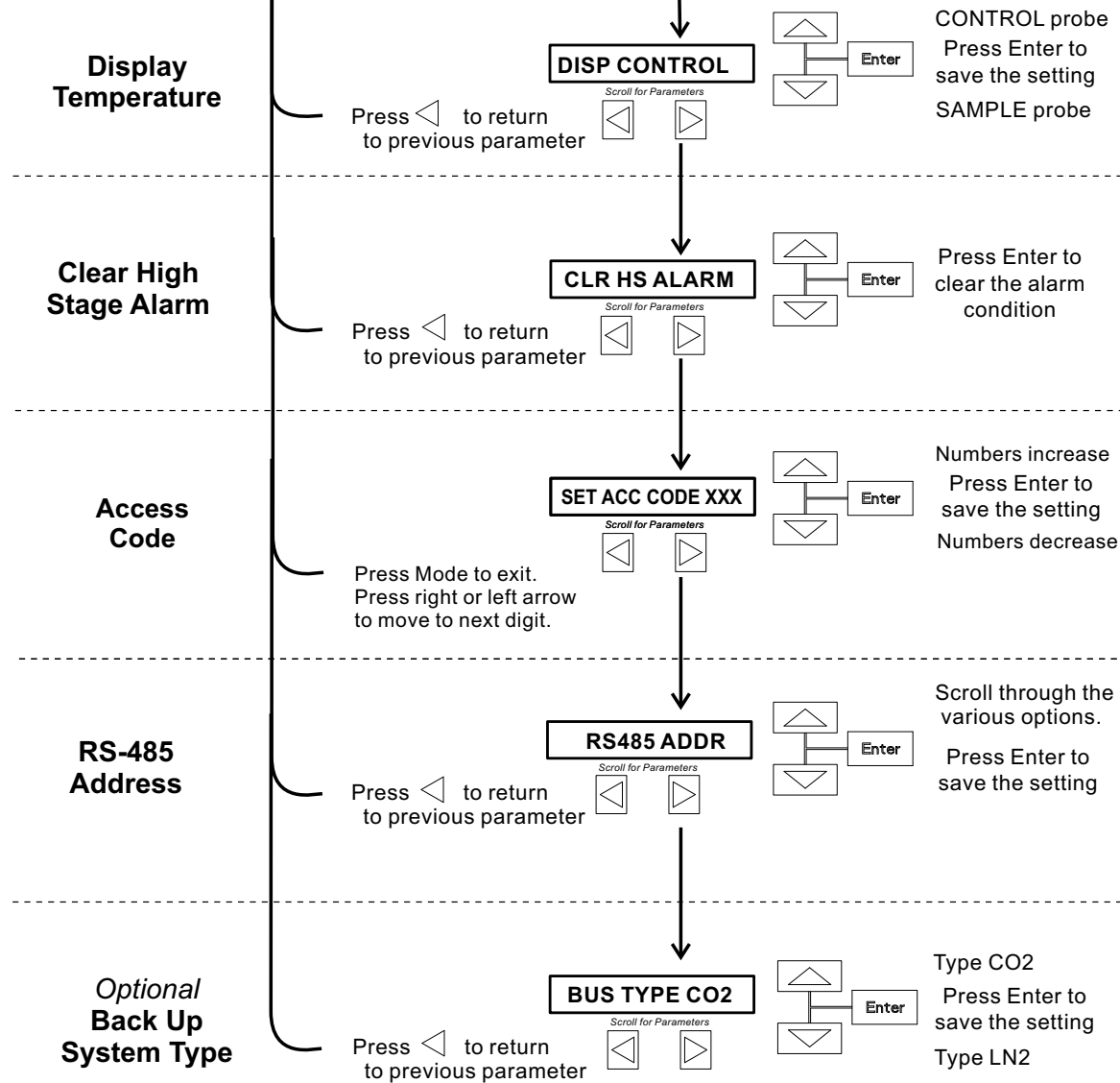

Configuration Mode, Chart 3-1, Page 3 of 3

refer to previous page

To Configure: ↑

Cold
Excursion

Press ◀ to return
to previous parameter

COLD EX = -XX

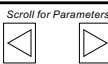

Warm
Excursion

Press ◀ to return
to previous parameter

WARM EX = -XX

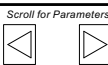

Reset
Excursions

Press ◀ to return
to previous parameter

RST EXCUR

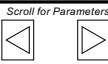

Press Enter to
reset the cold
and warm
excursion values

Section 4 Alarms

The Revco CxF freezer alarm system is shown below. When an alarm is active, a message appears in the LED message center. Press the Silence key to mute the audible alarm for the ringback period. The visual alarm continues until the freezer returns to a normal condition. The alarms are momentary alarms only. If an alarm condition occurs and then returns to normal, the freezer automatically clears the alarm condition and the message center.

Table 4-1. Alarms

Description	Message	Delay	Ringback	Relay
No alarm condition exists	SYSTEM OK	----	----	----
Power Failure	POWER FAIL	1 min.	15 min.	Yes
High Temperature Alarm	TEMP IS HIGH	1 min.	15 min.	Yes
Low Temperature Alarm	TEMP IS LOW	1 min.	15 min.	Yes
Door Ajar	DOOR IS OPEN	1 min.	15 min.	No
Low Battery*	LOW BATTERY	1 min.	8 hours	No
Low BUS Battery (optional)	LOW BUS BATT	1 min.	15 min.	No
Control Probe Failure	CNT PRB FLT	1 min.	15 min.	Yes
Heat Exchanger Probe Failure **	HSHX PRB FLT	1 min.	15 min.	No
Condenser Probe	COND PRB FLT	1 min.	15 min.	No
Sample Probe Failure (optional)	SMPL PRB FLT	1 min.	15 min.	No
High Stage System Failure **	HS SYST FAIL	1 min.	15 min.	YES
Condenser Hot Condition	HOT CONDENSER	1 min.	none	No
Wrong Power	WRONG POWER	0 min.	none	YES
Micro Board Failure	MICRO FAIL	0 min.	15 min.	YES

All alarm delays and ringback times are +30 seconds.

**The automatic battery test runs immediately on power-up, then every 8 hours thereafter.*

*** -86C units only*

High Stage System Failure Alarm (-86C units only)

This condition is created when the high stage compressor and fans run for 30 minutes and are not capable of cooling the interstage heat exchanger to the proper temperature. Under this condition, the high stage compressor and fans will turn off after 30 minutes and an audible and visual alarm will occur along with the "HS SYST FAIL" message in the LED message center.

Multiple Alarms

When multiple alarm conditions occur, active messages are displayed in the message center one at a time, updating at 5 second intervals. Pressing Silence during multiple alarms causes all active alarms to be silenced and to ring back in 15 minutes.

Micro Board Failure Alarm

An internal communication failure has occurred with the micro board. During this alarm, the compressor(s) attempt to run continuously. However, with this type of failure, freezer operation becomes undependable.

Lost Communication

Communication between the micro board and the display board has been lost. Under this condition, the visual alarm flashes along with dashes in the temperature display (----). Contact Technical Services.

Error	High End Message	Notes
Er00	"INV. MODEL"	<p>Name: Improper model selected.</p> <p>Description: Indicates that DIP SW3 has not selected a proper model or can't be accessed properly.</p> <p>Response: Display shows "Er00" and will not start-up until a proper model is selected. Contact Technical Services.</p>
ErA1	" NO FREQUENCY"	This error condition will prevent peripherals (fans, compressors, etc.) from powering up with the incorrect voltage.
ErC1	"FREQ <50Hz"	<p>Name: Voltage/Frequency failure</p> <p>Description: Indicates the measured RMS line voltage did not agree with the logic level sensed by the micros provided by the installed high voltage PCB; or the measured RMS voltage is not within a tolerable range (<180VAC < 270 for 230VAC unit / <85 VAC < 160 for 115VAC unit); or the frequency measured over 10 cycles was not within a tolerable range (55 Hz < Freq < 70 Hz for 60 Hz units / 40 Hz < Freq < 55 Hz for 50 Hz units)</p>
Erd1	"FREQ >60Hz"	
ErE1	"VAC < 180V"	<p>Response: This condition is checked at power on reset and if it is active the unit will NOT power up. The unit will indefinitely display "Er_1" in the display and continue to monitor the frequency and voltage. Furthermore, the audible alarm will sound. Other startup error messages may be displayed prior to this message; however, the system will stop the startup sequence for this condition.</p>
ErF1	"VAC > 260V"	<p>ErA1 .. No pulses (zero crossings) detected to determine frequency (50 / 60 Hz)</p> <p>ErC1 .. Frequency detected is below 50 Hz</p> <p>Erd1 .. Frequency detected is above 60 Hz (Possible noise spikes on supply voltage)</p>
Erg1	"VAC < 85V"	<p>ErE1 .. Unit is 230V and the voltage detected is below the low limit (180VRMS)</p> <p>ErF1 .. Unit is 230V and the voltage detected is above the high limit (260VRMS)</p> <p>Erg1 .. Unit is 115V and the voltage detected is below the low limit (85VRMS)</p>
ErH1	"VAC > 160V"	<p>ErH1 .. Unit is 115V and the voltage detected is above the high limit (160VRMS)</p>

Section 4

Alarms

Error (cont.)	High End Message	Notes
Er02	"CNT PRB FLT"	<p>Name: Control (Cabinet) Sensor Failure</p> <p>Description: This condition indicates that the control sensor has failed to produce a valid reading for ≥ 12 consecutive reads (~60 seconds).</p> <p>Response: The unit will stage both compressors on (if necessary) and the unit will attempt to head to bottom out. If the sensor recovers, the system will begin to operate normally and respond to the temperature feedback. The remote alarm contacts will become active regardless of the key position for this mode of failure. 'Er02' will be added to the main display queue and the last valid cabinet temperature value will not be displayed</p>
Er03	"HSHX PRB FLT" -86C units only	<p>Name: Heat Exchange Sensor Failure</p> <p>Description: This condition indicates that the heat exchange sensor has failed to produce a valid reading for ≥ 12 consecutive reads (~60 seconds).</p> <p>Response: The display will show "Er03" only when the button sequence to read the heat exchange sensor is depressed.</p>
Er05	N/A	<p>Name: Display Firmware Integrity Failure</p> <p>Description: The display firmware has failed to pass its CRC CCITT checksum integrity test.</p> <p>Response: The display performs this check at startup and the display board will fail to startup with out any error indication if it does not pass this at power on.</p>
Er06	N/A	<p>Name: Micro Firmware Integrity Failure</p> <p>Description: The micro firmware has failed to pass its CRC CCITT checksum integrity test.</p> <p>Response: This is checked at power on reset and the "Er06" will be displayed for ~10 seconds at startup if this condition exists.</p>
Er07	"MICRO FAIL"	<p>Name: Micro Fail - CS5521 SPI Failure / UISR Failure</p> <p>Description: This condition indicates a micro board failure due to either the SPI bus is unable to communicate with the ADC device or a UISR event caused the microcontroller to be in an unstable state.</p> <p>Response: The unit will try to recover from this fault three times by a hardware reset of the micro board. In the event that the system couldn't rectify the issue, the following sequence of events will occur:</p> <ol style="list-style-type: none"> 1. Remote alarm contacts will become active. 2. Buzzer will annunciate audibly and will have a ringback of 15 minutes. 3. "Seven segment" display will show "Er07". 4. The -86C system will have 10 minute staging between the high stage compressor and the low stage compressor activation (-40C units will activate the compressor). 5. The system will go to bottom out temperatures.

Error (cont.)	High End Message	Notes
Er09	N/A	<p>Name: Stuck Button</p> <p>Description: This condition indicates that the display board has a stuck button.</p> <p>Response: The Er09 will show on the display periodically.</p>
Er11	"COND PRB FLT"	<p>Name: Condenser Probe Sensor Failure</p> <p>Description: This condition indicates that the condenser probe sensor has failed to produce a valid reading for ≥ 12 consecutive reads (~60 seconds).</p> <p>Response: The display shows "Er11".</p>
N/A	"SMPL PRB FLT"	<p>Name: Sample Probe Sensor Failure</p> <p>Description: This condition indicates that the sample probe sensor has failed to produce a valid reading for ≥ 12 consecutive reads (~60 seconds).</p> <p>Response: The message center shows "SMPL PRB FLT".</p>
dErr	N/A	<p>This is a general display error in which the value being displayed can not be represented within the characters provided.</p>
(four dashes) ---- in display	N/A	<p>Name: Lost Communication</p> <p>Description: Communication between the micro board and the display board has been lost. Under this condition, the visual alarm flashes along with dashes in the temperature display (----). Contact Technical Services.</p>

Section 5 Maintenance

Wipe down the freezer exterior using soap and water and a general use laboratory disinfectant. Rinse thoroughly with clean water and dry with a soft cloth.

Caution Avoid the excessive use of water around the control area due to the risk of electrical shock. Damage to the controls may also result. ▲

Clean Air Filter

The air filter should be cleaned a minimum of four times per year.

1. Open the lower panel door by grasping the handle.
2. Locate the grille on the door. See Figures 5-1 and 5-2. Grasp the middle of the grille material and gently pull out to remove.
3. Wash the filter material using water and a mild detergent.
4. Dry by pressing between two towels.
5. Install the filter back into the grille and close the door.

Depending upon environmental conditions, the filter may need to be cleaned or replaced more frequently. If the filter becomes torn or excessively dirty, a replacement can be purchased from Thermo. Order part number 398216 for 3 cu. ft. units, or 398217 for 13, 17, and 20 cu. ft. units.

Clean Condenser

The condenser should be cleaned a minimum of once per year.

1. Open the lower panel door by grasping the handle. See Figures 5-1 and 5-2.
2. Using a vacuum cleaner, exercising care to not damage the condenser fins, clean the condenser.

Depending upon environmental conditions, the condenser may need to be cleaned more frequently.

Defrost Chamber

1. Remove all product and place it in another freezer.
2. Turn the unit off and disconnect it from the power source.
3. Turn off the battery switch (O). See Figures 5-1 and 5-2.

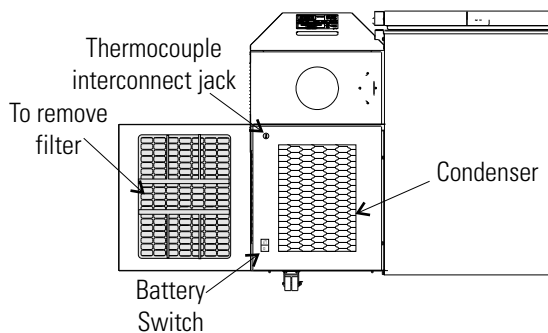

Figure 5-1. Component Locations

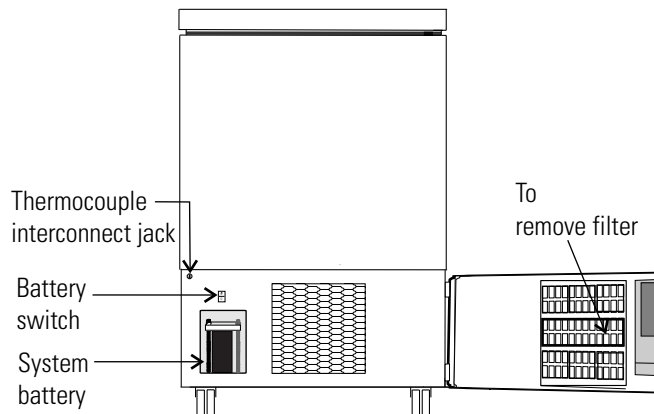

Figure 5-2. 3 cu ft Component Locations

4. Open the lid and remove sub-lids. Place towels on the chamber floor.
5. Allow the frost to melt and become loose. Remove with a soft cloth.
7. After defrosting is complete, clean the interior with a non-chloride detergent. Rinse thoroughly with clean water and dry with a soft cloth.
8. Plug unit in and turn power switch on.
9. Turn the battery power switch to Standby mode (Ⓞ).
10. Allow the freezer to operate empty overnight before reloading the product.

Prepare the Unit for Storage

Defrost the unit as previously described. This prepares the unit for storage. Turn Off the battery power switch (O). Turn Off the freezer power switch.

Note If the unit has been in service, turn it off and disconnect the power cord connector before proceeding with any maintenance. ▲

Clean Lid Gasket

The lid gasket should be cleaned a minimum of once per month. Using a soft cloth, remove any frost build-up from the gasket, sub-lids and lids. The clean gasket alarm occurs every three months as a reminder to remove frost build-up from the gasket and doors. Press the Silence key to mute the audible alarm. The lid gasket may need to be cleaned more frequently if dirt or excessive frost build-up prevents the door from closing properly.

Replace Battery(s)

The following instructions describe the battery replacement procedure for specific models.

All Models Except 3 cu ft

1. Open the lower panel door by grasping the handle and pulling.
2. Locate the battery power switch (Figure 5-1). Turn the battery power switch to the Off position (O).
3. Remove the four screws holding the recorder bezel to gain access to the battery.
4. Remove the three nuts securing the battery bracket. See Figure 5-1.
5. Remove the bracket and old battery. Discard properly. Install the new battery and secure.
6. Reconnect the battery (red to positive and black to negative).
7. Replace the recorder bezel.
8. Turn the battery power switch to Standby mode (⏻).
9. Close lower panel door.

3 cu ft Models

1. Open the lower panel door by locating the handle on the underside of the door and pulling.
2. Locate the battery power switch (Figure 5-2). Turn the battery power switch to the Off position (O).
3. Remove the two nuts securing the battery bracket. See Figure 5-2.
5. Remove the bracket and old battery. Discard properly. Install the new battery and secure.
6. Reconnect the battery (red to positive and black to negative).
7. Replace the recorder bezel.
8. Turn the battery power switch to Standby mode (⏻).
9. Close lower panel door.

Note For a consistent and dependable charge, replace the battery every 2 years. Replacement batteries must be rechargeable and are available from Thermo. Refer to the parts list for stock number and description of the replacement batteries (P/N 400159). Dispose of the used batteries in a safe manner and in accordance with good environmental practices. ▲

Check Battery(s)

All Models except 3 cu ft (Figure 5-1):

1. Locate the power switch on the back of the unit. Turn the switch off. (O).
2. Open the lower door on the front left corner of the sidecar. Turn off the battery switch (O).
3. Remove all the screws from the side panel, except the lower ones. Just loosen these and lift the panel off.
4. The battery is rectangular in shape, located above the compressor compartment, to the right and behind the relay box. Remove the three wingnuts that secure the cover on the battery. Remove the cover.
5. Remove the battery from the mounting bracket.
6. Disconnect the red and black wires from the battery.
7. Use a voltmeter set to DC volts. Matching the wire colors, connect the meter to the battery.
8. If the voltage reads less than 10.8 volts, replace the battery. If above 10.8, re-install as previously.
9. Re-install side panel. Turn the battery power switch to Standby mode (Ⓞ), then close lower door. Turn power switch On.

3 cu ft Models (Figure 5-2):

1. To gain access to the battery, open the lower door by grasping the bottom left corner. The battery is rectangular in shape, located on the left side of the filter compartment.
2. Directly above the battery(s) is the battery power switch. Turn the battery power switch to the off position (O).
3. Remove the three wingnuts that secure the cover on the battery. Remove the cover.
4. Remove the battery from the mounting bracket.
5. Disconnect the red and black wires from the battery.
5. Use a voltmeter set to DC volts. Matching the wire colors, connect the meter to the battery.
6. If the voltage reads less than 10.8 volts, replace the battery. If above 10.8, re-install as previously.
7. Turn the battery power switch to Standby mode (Ⓞ).
8. Close lower door.

PREVENTIVE MAINTENANCE

Freezers

Your equipment has been thoroughly tested and calibrated before shipment. Regular preventive maintenance is important to keep your unit functioning properly. The operator should perform routine cleaning and maintenance on a regular basis. For maximum performance and efficiency, it is recommended that the unit be checked and calibrated periodically by a qualified service technician.

The following is a condensed list of preventive maintenance requirements. See the specified section of the instruction manual for further details.

We have qualified service technicians, using NIST traceable instruments, available in many areas. For more information on Preventive Maintenance or Extended Warranties, please contact the Technical Services Department.

Cleaning and calibration adjustment intervals are dependent upon use, environmental conditions and accuracy required.

Tips:

- Fill an upright by starting at the bottom near the probe and add racks to one shelf at a time. Allow freezer to recover to set point between shelves.
- Fill a chest by starting at the left side near the probe. Filling with room temperature racks will result in a long pull-down time.
- Fill unit with frozen product to help overall performance; frozen water jugs, for example.
- Always make certain the vacuum relief port is free of frost and ice, to allow for timely re-entry into the freezer after a door opening.

Action	Monthly	Yearly	Every 2 Years
Verify ambient temperature, <90°F	✓		
Check and clean probe cover, gaskets, hinges and lid(s) of ice and snow. See Figure 1-5 for probe location. See "Clean Lid Gasket".	✓ <i>More frequent cleaning may be required, depending on use and environmental conditions.</i>		
Check air filter. Clean or replace as needed. See "Clean Air Filter".		✓ 4X	
Check alarm back-up battery. See "Connect Unit to Electrical Power" in Section 1 and "Replace Battery" in Section 5.	✓		**Replace
Check condenser fan motor for unusual motor noise or vibration.		✓	
* Verify and document calibration, at the minimum, annually. See Section 2 Calibration.		✓	
* Clean condenser compartment and wipe off condenser. See "Clean Condenser" in Section 5.		✓	

* *Qualified service technicians only*

** *Dispose of properly, according to all state and federal regulations.*

Section 6 Factory Installed Options

Back Up System (BUS) - P/N 1950533, 1950535

Note Before installation of BUS components, make sure the power to the freezer is disconnected, the battery switch is turned off (O) and the freezer has warmed to ambient temperature. ▲

The built-in BUS (back up system) will keep the freezer chamber temperature below the critical level in the event of a power or equipment failure. If power to the freezer fails, or temperature increases to the back up alarm set point, the BUS injects liquefied gas into the chamber to keep the chamber temperature within the specified range.

Install Injection Assembly

The BUS operates on an internal 12-volt, rechargeable battery which is kept charged during normal operation by the integral battery charger.

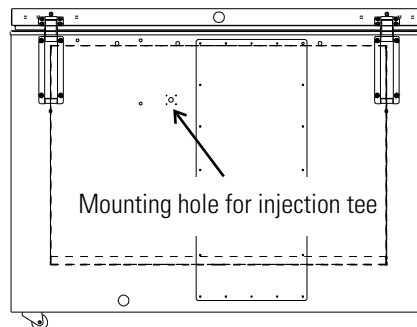

Figure 6-1. Mounting location

1. Locate the mounting hole for installing the injection tee assembly. See Figure 6-1.

Note Cover open end of injection assembly with tape to keep insulation from entering the nipple. ▲

2. Slide 3/8" flatwasher over open end of nipple.
3. Insert the covered end of the injection assembly through exterior hole.

Install Injection Assembly (continued)

4. Remove the tape covering the end of the nipple and install the 1/8" NPT brass tee on the open end of the nipple. Place Permagum sealant between the brass tee and the interior top.
5. Go to the interior and seal around injection assembly with Permagum.

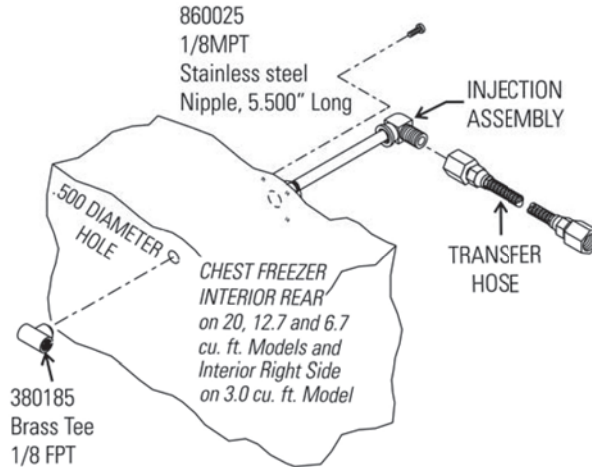

Figure 6-2. Injection Assembly

6. Install the transfer hose connecting one end to the injection assembly, the other end to the solenoid valve. Install the solenoid valve to the supply source. The solenoid mounting bracket is not required and may be discarded.

Note When selecting a CO₂ supply cylinder, it must be equipped with a siphon tube. ▲

Install Temperature Probe

1. Plug the solenoid/probe connector into the BUS connection. Loop the probe wire back into the base/side car. Secure the connector with a screw on the ends of the connector. The connector is keyed.
2. Route the temperature probe through the probe port. The probe port is located in the upper right corner (viewed from the side) of 12.7 and 20 cu. ft. models, and in the lower right corner (viewed from the back) of 3.0 cu. ft. models.

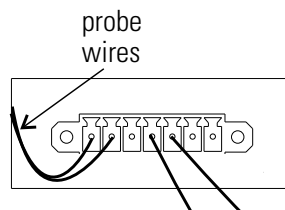

Figure 6-3. Probe and Solenoid Connections

Install Temperature Probe (continued)

- Carefully remove the existing Permagum sealant from around the probe port opening.
- Open the freezer lid and locate the probe cover on the upper front left wall. Remove the two Phillips head screws securing the probe cover (see Figure 6-5).

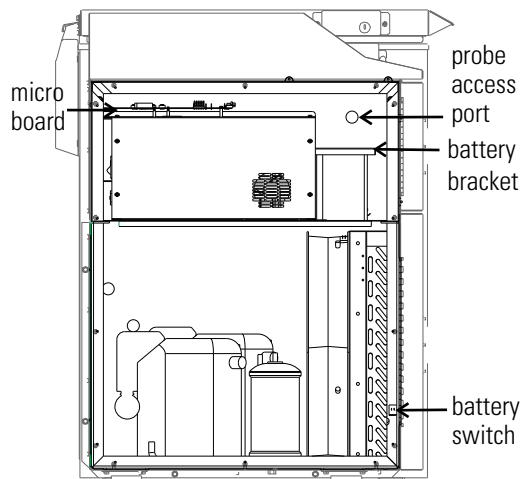

Figure 6-4. Probe Access Port

- Route the BUS probe through the probe port, approximately 12". Secure the back-up probe to the temperature probe using a small tie wrap (Figure 6-5).

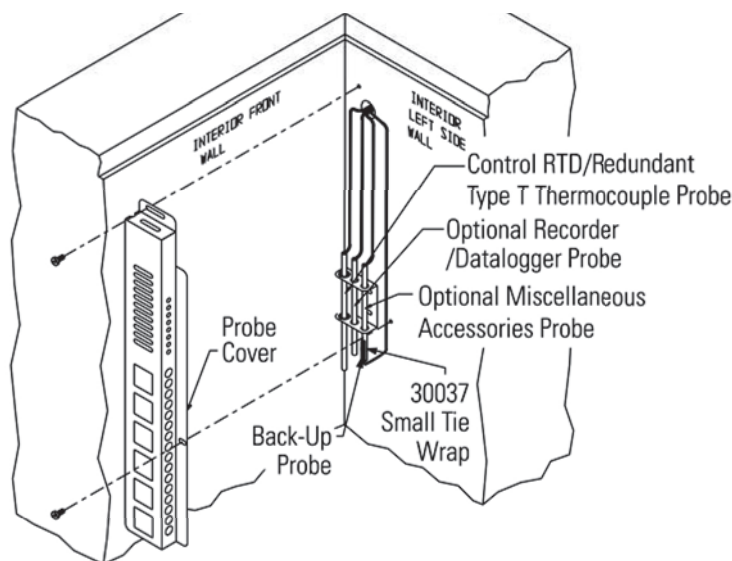

Figure 6-5. Probe location

- Seal around the interior and exterior opening of the probe port with Permagum sealant.
- Reinstall the probe cover (Figure 6-5).

Connect Probe/Solenoid Harness

1. Carefully coil the extra probe lead in the compressor compartment, and secure it to the compartment wall with a tie wrap and tie wrap anchor provided. Additional tie wraps and anchors may be used to secure the probe lead to the exterior back wall of the freezer.
2. Loosen the terminal screws on the solenoid. Slide the spade lug connectors under the screws and tighten to secure.
3. Connect power to the freezer. Turn the freezer On, with battery switch Off (O).
 - a. The Solenoid Engaged light on the BUS control panel illuminates (no injection occurs). This light stays on until the unit is below BUS setpoint.
 - b. The Low Battery indicator may also illuminate.
4. Turn the battery switch to Standby mode (Ⓞ) to charge both batteries.

BUS Control Panel

The following section describes the configuration and operation of the BUS.



Warning When activated, this unit injects liquid nitrogen or carbon dioxide. Liquid nitrogen can cause serious freezing (frostbite) if it comes in contact with unprotected skin or eyes. Nitrogen suppresses oxygen levels and may cause suffocation if area is not well ventilated. Refer to Appendix A for the proper handling of liquid LN₂. ▲

Caution Make sure the pressure relief valve on any LN₂ tank is adjusted to 30 PSI maximum blow-off. ▲

Warning Carbon dioxide gas suppresses oxygen levels and may cause suffocation if area is not well ventilated. Refer to “Handling Liquid CO₂ in Appendix B of this manual. ▲

BUS Control Panel (continued)

Figure 6-6. BUS Control Panel

Power - indicates the unit has AC power.

Low Battery - battery charge is low. The battery needs replaced or recharged.

Solenoid Engaged - BUS has opened the solenoid so it can inject gas (CO₂ or LN₂).

Press-To-Test - Activates the solenoid and injects LN₂ or CO₂ into the freezer chamber as long as the button is depressed. The solenoid engaged indicator should light. If the Low Battery indicator lights during the test, replace the BUS battery.

Note The solenoid will not engage if lid is open. ▲

Configure Optional Back Up System (BUS)

The optional BUS can be configured for LN₂ or CO₂ supply. Section 3 - Configuration contains instructions for setting the BUS type.

Set Optional BUS Set Point

The optional back up system is designed to inject CO₂ or LN₂ into the freezer compartment if the temperature rises above back up system set point. To set the BUS set point:

1. Press the Mode key until the Settings indicator lights.
2. Press right arrow until "BACKUP = -XX" displays in message center.
3. Press up or down arrow key until desired BUS set point is displayed.
4. Press Enter to save the setting.
5. Press the Mode key until the Run indicator lights, or press the right or left arrow to go to the next or previous parameter.

If no control keys are pressed, the freezer will automatically return to RUN mode after 5 minutes.

Set Optional BUS Set Point (continued)



Warning Changing operating temp set point can affect BUS set point. BUS set point self adjusts to maintain a temp of at least 10°C above the operating temp set point. ▲

Note The BUS set point cannot be set any colder than the high temperature alarm set point. (See Section 1 - Setting the High Temperature Alarm). If the back-up system is installed with CO₂, then -65°C is the coldest BUS set point that can be used (if the cabinet set point is -75°C or colder). ▲

Test the BUS

After the freezer has stabilized and both batteries are fully charged, the BUS can be tested to verify proper operation.

1. Disconnect the AC power to the freezer by turning power switch off.
2. As the freezer warms up, verify the BUS injects at the desired temperature. Displayed temperature may vary by a few degrees from inject temperature due to the differences in probe locations.

Disconnect Fitting Assembly, Transfer Hose

To disconnect the freezer back-up from the gas supply:

1. Close the supply valve.
2. Depress the test button on the Back-Up System control box to remove the gas from the line.
3. Slowly disconnect the fitting assembly from the supply (in the event that any gas remains in the line).

Chart Recorder

Figure 6-7. Recorder Details

Install Chart Paper

The following section describes the set up and operation of the optional chart recorder.

1. Open the plastic door of the recorder and press button #3 until the pen begins to move outward.
2. Unscrew the knob at the center of the chart and remove the paper.
3. Install the new chart paper, position the paper to the correct time line and replace the knob.
4. Remove the cap from the felt pen and press button #3.

Change Program

The chart recorder contains eight temperature ranges and is factory-programmed for the freezer. To change the recorder range:

1. Press and hold button #3 for one second, then let the pen move off the chart paper.
2. Press and hold for five seconds either button #1 or button #2.
3. Release the button and the green LED will begin to flash. Count the number of flashes to determine the present program setting.
4. To change the program setting, press the left or right arrows to increase or decrease the count.
5. When the desired program number is flashing, press button #3 to bring the pen arm back onto the chart. Recording will begin in the new program.

Program	From	To
1	-40	30°C
2	0	60°C
3	-100	38°C
4	-5	50°C
5	0	100°C
6	-100	200°C
7	-115	50°C
8	-10	70°C

Calibrate Chart Recorder

The recorder must be in service for 24 hours before performing the following calibration procedure.

1. Place an accurate thermometer in the chamber next to the recorder probe.
2. Temperature probes for the recorder are located in the left front corner of the freezer chamber (Figure 1-4).
3. After about three minutes, compare the thermometer reading with the chart recorder reading.

Section 6

Factory Installed Options

Calibrate Chart Recorder (continued)

4. If an adjustment is necessary, press the #1 button to move the pen to the left or the #2 to move the pen to the right. The button must be held about five seconds before the pen begins to move. Release the button when the pen position matches the thermometer.

Note The felt-tip pen on the recorder requires periodic replacement. Usually the ink will appear to fade before replacement becomes necessary. Additional pen tips may be purchased from Thermo. ▲

Section 7 Specifications

Number (Model)	ULT-390-10-A (5808)	ULT-390-10-V (5809)
Temperature Range	-50°C (-58°F) to -86°C (-123°F) in an 18C to 32C * (64.4F to 89.6F) ambient	
Exterior Dimensions	28.5"W x 43.8" H x 29.9" F-B (72.4cm x 111.3cm x 75.9cm) Add 7.9" (20.1cm) to F-B for wall spacer/handle.	
Interior Dimensions	18.5"W x 16.5"H x 18.5" F-B (47.0cm x 41.9cm x 47.0cm)	
Capacity	3.0 cu. ft. (84.9 liters)	
Refrigeration	Cascade system, (2) hermetically-sealed compressors	
Insulation	Non CFC, foamed-in-place urethane: 5.0" (12.7cm) cabinet; 2.0" (5.0cm) lid; 1.0" (12.5cm) sub-lids	
Electrical - nominal voltage ±10%	120VAC, 1 PH, 60 Hz, 10.5 FLA Operating Range: 108-130VAC	230VAC, 1 PH, 50 Hz, 5.4 FLA Operating Range: 208-240VAC
Breaker Requirements	15 Amp, Dedicated Circuit, 15 Amp Time Delay Breaker	15 Amp, Dedicated Circuit, 15 Amp Time Delay Breaker
Shipping Weight	432 lbs. (196kg)	

Number (Model)	ULT-1390-10-A (5815)	ULT-1390-10-D (5812)	ULT-1390-10-V (5813)
Temperature Range	-50°C (-58°F) to -86°C (-123°F) in an 18C to 32C * (64.4F to 89.6F) ambient		
Exterior Dimensions	72.0"W x 40.5" H x 33.4" F-B (182.9cm x 102.9cm x 84.8cm) Add 7.9" (20.1cm) to F-B for wall spacer/handle.		
Interior Dimensions	42.5"W x 28.0"H x 18.5" F-B (108.0cm x 71.1cm x 47.0cm)		
Capacity	12.7 cu. ft. (360 liters)		
Refrigeration	Cascade system, (2) hermetically-sealed compressors		
Insulation	Non CFC, foamed-in-place urethane: 5.0" (12.7cm) cabinet; 2.0" (5.0cm) lid; 1.0" (12.5cm) sub-lids		
Electrical - nominal voltage ±10%	120VAC, 1 PH, 60 Hz, 16.0 FLA Operating Range: 108-130VAC	230VAC, 1 PH, 50 Hz, 12.0 FLA Operating Range: 208-240VAC	230VAC, 1 PH, 60 Hz, 12.0 FLA Operating Range: 208-240VAC
Breaker Requirements	20 Amp, Dedicated Circuit, 20 Amp Time Delay Breaker	15 Amp, 230VAC, Dedicated Circuit, 15 Amp Time Delay Breaker	15 Amp, Dedicated Circuit, 15 Amp Time Delay Breaker
Shipping Weight	716 lbs. (325kg)		

Section 7
Specifications

Number (Model)	ULT-1790-10-A (5818)	ULT-1790-10-V (5819)	ULT-1790-10-D (5822)
Temperature Range	-50°C(-58°F) to -86°C(-123°F) in an 18C to 32C * (64.4F to 89.6F) ambient		
Exterior Dimensions	87.6"W x 40.5" H x 33.8" F-B (222.5cm x 102.9cm x 85.9cm) Add 7.9" (20.1cm) to F-B for wall spacer/handle.		
Interior Dimensions	58.8"W x 28.0"H x 18.5" F-B (149.4cm x 71.1cm x 47.0cm)		
Capacity	17.0 cu. ft. (481.4 liters)		
Refrigeration	Cascade system, (2) hermetically-sealed compressors		
Insulation	Non CFC, foamed-in-place urethane: 5.0" (12.7cm) cabinet; 2.0" (5.0cm) lid; 1.0" (12.5cm) sub-lids		
Electrical - nominal voltage ±10%	120VAC, 1 PH, 60 Hz, 16.0 FLA Operating Range: 108-130VAC	230VAC, 1 PH, 50 Hz, 12.0 FLA Operating Range: 208-240VAC	230VAC, 1 PH, 60 Hz, 12.0 FLA Operating Range: 208-240VAC
Breaker Requirements	20 Amp, Dedicated Circuit, 20 Amp Time Delay Breaker	15 Amp, Dedicated Circuit, 15 Amp Time Delay Breaker	15 Amp, Dedicated Circuit, 15 Amp Time Delay Breaker
Shipping Weight	821 lbs. (372kg)		

Number (Model)	ULT-2090-10-A (5821)	ULT-2090-10-V (5820)	ULT-2090-10-D (5823)
Temperature Range	-50°C(-58°F) to -86°C(-123°F) in an 18C to 32C * (64.4F to 89.6F) ambient		
Exterior Dimensions	96.0"W x 40.5" H x 33.4" F-B (243.8cm x 102.9cm x 84.8cm) Add 7.9" (20.1cm) to F-B for wall spacer/handle.		
Interior Dimensions	66.5"W x 28.0"H x 18.5" F-B (168.9cm x 71.1cm x 47.0cm)		
Capacity	20.0 cu. ft. (566.3 liters)		
Refrigeration	Cascade system, (2) hermetically-sealed compressors		
Insulation	Non CFC, foamed-in-place urethane: 5.0" (12.7cm) cabinet; 2.0" (5.0cm) lid; 1.0" (12.5cm) sub-lids		
Electrical - nominal voltage ±10%	120VAC, 1 PH, 60 Hz, 16.0 FLA Operating Range: 108-130VAC	230VAC, 1 PH, 50 Hz, 12.0 FLA Operating Range: 208-240VAC	230VAC, 1 PH, 60 Hz, 12.0 FLA Operating Range: 208-240VAC
Breaker Requirements	20 Amp, Dedicated Circuit, 20 Amp Time Delay Breaker	15 Amp, Dedicated Circuit, 15 Amp Time Delay Breaker	15 Amp, Dedicated Circuit, 15 Amp Time Delay Breaker
Shipping Weight	833 lbs. (378kg)		

Number (Model)	ULT350-10-A (5308)	ULT350-10-V (5309)
Temperature Range	-10°C (-14°F) to -40°C (-40°F) in an 18C to 32C * (64.4F to 89.6F) ambient	
Exterior Dimensions	28.5"W x 43.8" H x 29.9" F-B (72.4cm x 111.3cm x 75.9cm) Add 7.9" (20.1cm) to F-B for wall spacer/handle.	
Interior Dimensions	18.5"W x 16.5"H x 18.5" F-B (47.0cm x 41.9cm x 47.0cm)	
Capacity	3.0 cu. ft. (84.9 liters)	
Refrigeration	Hermetically-sealed compressor	
Insulation	Non CFC, foamed-in-place urethane: 5.0" (12.7cm) cabinet; 2.0" (5.0cm) lid; 1.0" (12.5cm) sub-lids	
Electrical - nominal voltage ±10%	120VAC, 1 PH, 60 Hz, 6.0 FLA Operating Range: 108-130VAC	230VAC, 1 PH, 50 Hz, 3.0 FLA Operating Range: 208-240VAC
Breaker Requirements	15 Amp, Dedicated Circuit, 15 Amp Time Delay Breaker	15 Amp, Dedicated Circuit, 15 Amp Time Delay Breaker
Shipping Weight	395 lbs (179kg)	

Number (Model)	ULT1350-10-A (5315)	ULT1350-10-D (5312)	ULT1350-10-V (5313)
Temperature Range	-10°C (-14°F) to -40°C (-40°F) in an 18C to 32C * (64.4F to 89.6F) ambient		
Exterior Dimensions	72.0"W x 40.5" H x 33.4" F-B (182.9cm x 102.9cm x 84.8cm) Add 7.9" (20.1cm) to F-B for wall spacer/handle.		
Interior Dimensions	42.5"W x 28.0"H x 18.5" F-B (108.0cm x 71.1cm x 47.0cm)		
Capacity	12.7 cu. ft. (360 liters)		
Refrigeration	Hermetically-sealed compressor		
Insulation	Non CFC, foamed-in-place urethane: 5.0" (12.7cm) cabinet; 2.0" (5.0cm) lid; 1.0" (12.5cm) sub-lids		
Electrical - nominal voltage ±10%	120VAC, 1 PH, 60 Hz, 6.0 FLA Operating Range: 108-130VAC	230VAC, 1 PH, 60 Hz, 3.0 FLA Operating Range: 208-240VAC	230VAC, 1 PH, 50 Hz, 3.0 FLA Operating Range: 208-240VAC
Breaker Requirements	20 Amp, Dedicated Circuit, 20 Amp Time Delay Breaker	15 Amp, Dedicated Circuit, 15 Amp Time Delay Breaker	15 Amp, Dedicated Circuit, 15 Amp Time Delay Breaker
Shipping Weight	659 lbs. (299kg)		

Section 7
Specifications

Number (Model)	ULT1750-10-A (5318)	ULT1750-10-D (5319)	ULT1750-10-V (5322)
Temperature Range	-10°C (-14°F) to -40°C (-40°F) in an 18C to 32C * (64.4F to 89.6F) ambient		
Exterior Dimensions	87.6.0"W x 40.5" H x 33.8" F-B (222.5cm x 102.9cm x 85.9cm) Add 7.9" (20.1cm) to F-B for wall spacer/handle.		
Interior Dimensions	58.8"W x 28.0"H x 18.5" F-B (149.4cm x 71.1cm x 47.0cm)		
Capacity	17.0 cu. ft. (481.4 liters)		
Refrigeration	Hermetically-sealed compressor		
Insulation	Non CFC, foamed-in-place urethane: 5.0" (12.7cm) cabinet; 2.0" (5.0cm) lid; 1.0" (12.5cm) sub-lids		
Electrical - nominal voltage ±10%	120VAC, 1 PH, 60 Hz, 9.0 FLA Operating Range: 108-130VAC	230VAC, 1 PH, 60 Hz, 7.0 FLA Operating Range: 208-240VAC	230VAC, 1 PH, 50 Hz, 7.0 FLA Operating Range: 208-240VAC
Breaker Requirements	20 Amp, Dedicated Circuit, 20 Amp Time Delay Breaker	15 Amp, Dedicated Circuit, 15 Amp Time Delay Breaker	15 Amp, Dedicated Circuit, 15 Amp Time Delay Breaker
Shipping Weight	764 lbs. (347kg)		

Number (Model)	ULT2050-10-A (5321)	ULT2050-10-D (5320)	ULT2050-10-V (5323)
Temperature Range	-10°C (-14°F) to -40°C (-40°F) in an 18C to 32C * (64.4F to 89.6F) ambient		
Exterior Dimensions	96.0"W x 40.5" H x 33.4" F-B (243.8cm x 102.9cm x 84.8cm) Add 7.9" (20.1cm) to F-B for wall spacer/handle.		
Interior Dimensions	66.5"W x 28.0"H x 18.5" F-B (168.9cm x 71.1cm x 47.0cm)		
Capacity	20.0 cu. ft. (566.3 liters)		
Refrigeration	Hermetically-sealed compressor		
Insulation	Non CFC, foamed-in-place urethane: 5.0" (12.7cm) cabinet; 2.0" (5.0cm) lid; 1.0" (12.5cm) sub-lids		
Electrical - nominal voltage ±10%	120VAC, 1 PH, 60 Hz, 10.0 FLA Operating Range: 108-130VAC	230VAC, 1 PH, 60 Hz, 6.5 FLA Operating Range: 208-240VAC	230VAC, 1 PH, 50 Hz, 6.5 FLA Operating Range: 208-240VAC
Breaker Requirements	20 Amp, Dedicated Circuit, 20 Amp Time Delay Breaker	15 Amp, Dedicated Circuit, 15 Amp Time Delay Breaker	15 Amp, Dedicated Circuit, 15 Amp Time Delay Breaker
Shipping Weight	776 lbs. (352kg)		

Certifications

Declaration of Conformity is available from the factory

Safety Specifications

Indoor Use Only

Altitude - up to 2,000 meters

Temperature - 5°C to 43°C

Humidity - Maximum RH 80% for temperatures up to 31°C, decreasing linearly to 50% RH at 40°C

Mains Supply Fluctuations - Mains supply voltage fluctuations not to exceed $\pm 10\%$ of the nominal voltage

Installation Category II ¹

Pollution Degree 2 ²

Class of Equipment I

Intended Use

This product is intended for use as a General Purpose Laboratory Freezer for storing samples or inventory between -40 and -86C.

This unit is not intended for use in an explosive environment, nor to be used for the storage of flammable inventory. This unit is not intended for use in a Class II medical application as defined by Title 21 of the Federal Code of Regulations.

¹ Installation category (overvoltage category) defines the level of transient overvoltage which the instrument is designed to withstand safely. It depends on the nature of the electricity supply and its overvoltage protection means. For example, in CAT II which is the category used for instruments in installations supplied from a supply comparable to public mains such as hospital and research laboratories and most industrial laboratories, the expected transient overvoltage is 2500V for a 230V supply and 1500V for a 120V supply.

² Pollution degree describes the amount of conductive pollution present in the operating environment. Pollution degree 2 assumes that normally only non-conductive pollution such as dust occurs with the exception of occasional conductivity caused by condensation.

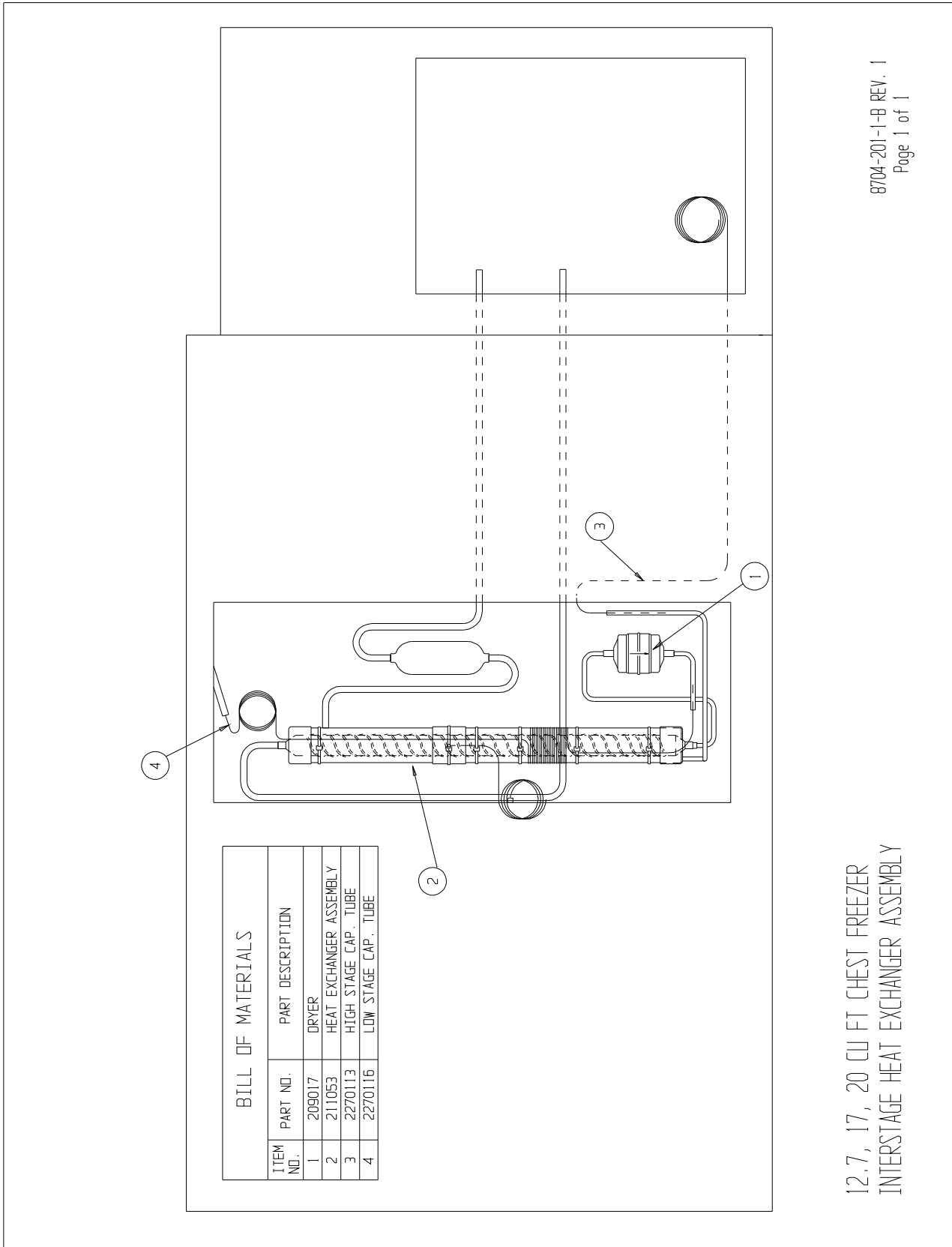

Section 8
Spare Parts

BILL OF MATERIALS

ITEM NO.	PART NO.	PART DESCRIPTION
1	202003	ACCUMULATOR ASSEMBLY
2	209019	DRYER
3	211044	HEAT EXCHANGER ASSEMBLY
4	227992	HIGH & LOW STAGE CAP. TUBE

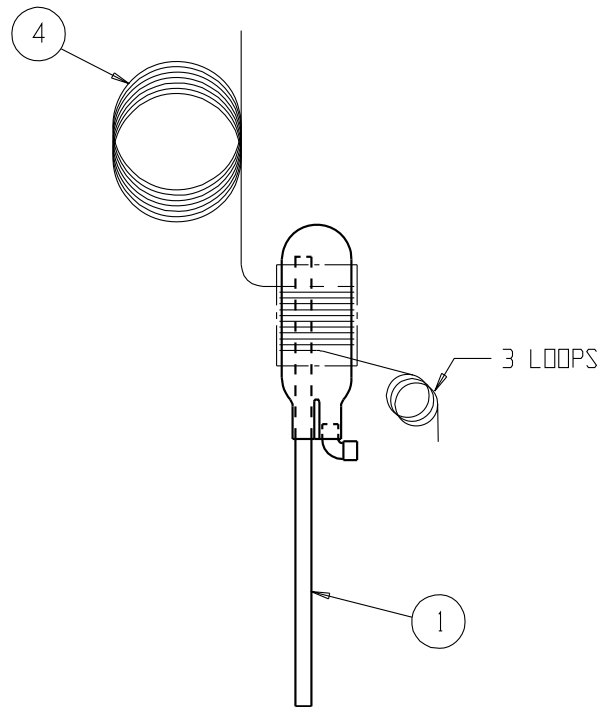
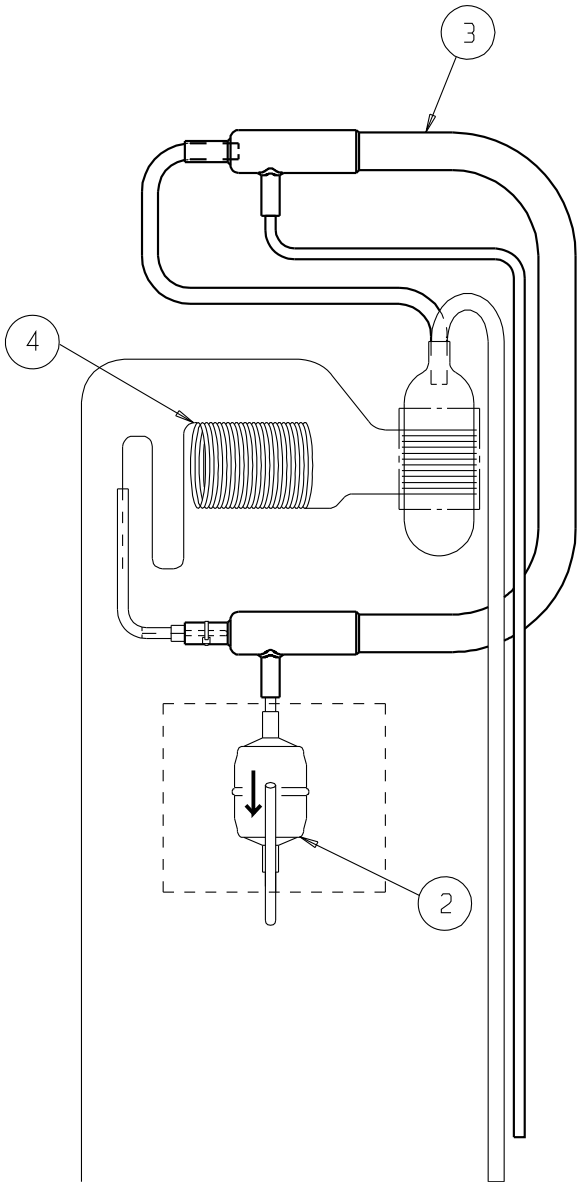

Exploded Drawing
3 cu ft Chest Freezer
Heat Exchanger

8700-201-1-B Rev. 0
Page 1 of 1

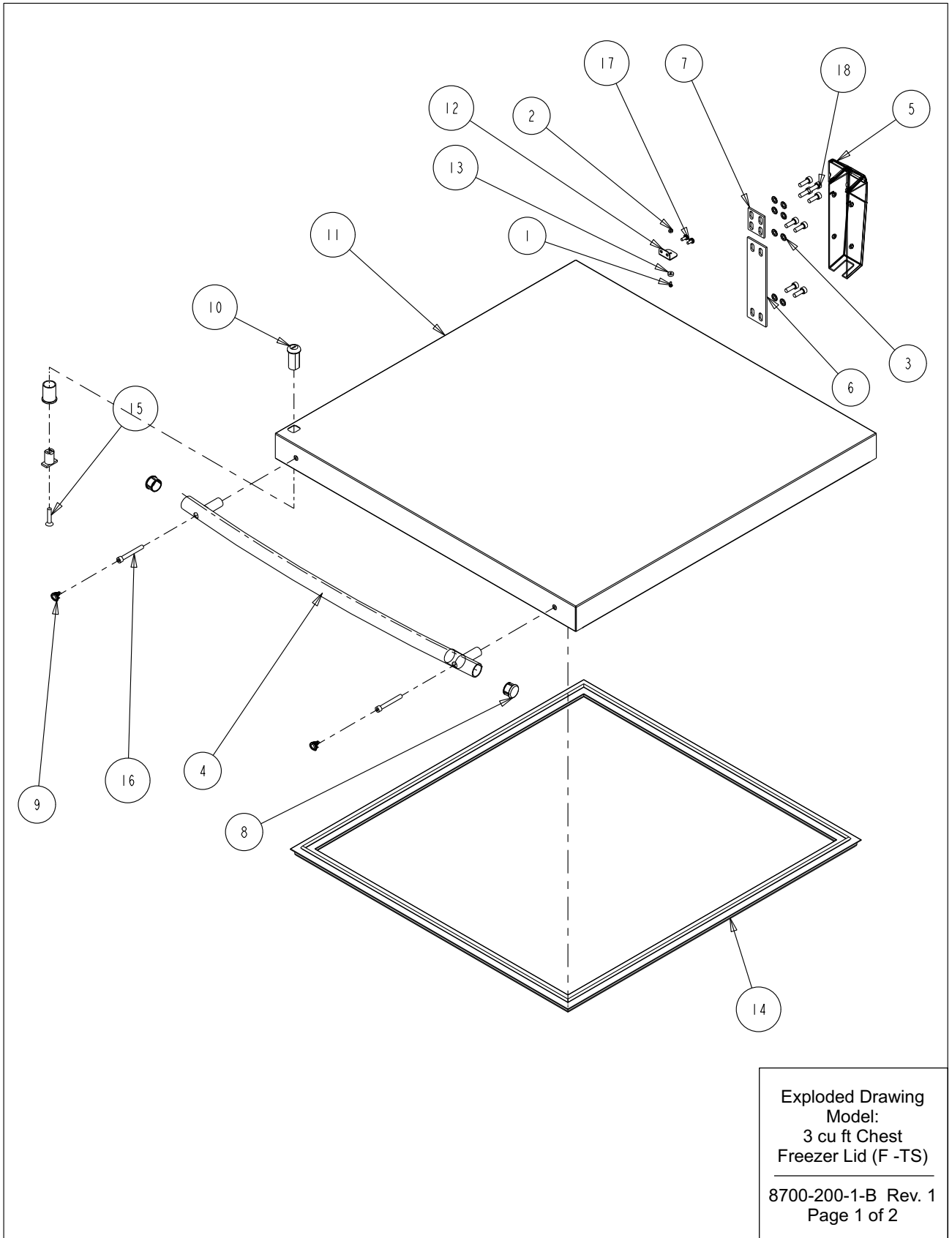

Section 8
Spare Parts

BILL OF MATERIALS		
ITEM NO.	PART NO.	PART DESCRIPTION
1	22130	#4-40 X 1/4 SS PHP SCREW
2	23005	#4-40 SS HEX NUT
3	23062	1/4 SS EXT TOOTH LOCKWASHER
4	115038	646 SID BLUE RADIUSED HANDLE
5	116136	SPRING LOADED HINGE
6	116137	HINGE SHIM LAYOUT
7	116138	HINGE SHIM LAYOUT
8	180314	THERMO ULT CHEST HANDLE END CAP
9	180315	ULT CHEST HANDLE SCREW COVER
10	195332	LOCK MOUNT ASSEMBLY
11	195950	3.0 CU. FT. CHEST FREEZER LID
12	195970	3/6.7 LID SWITCH MAGNET MOUNT
13	360257	SWITCH MAGNET
14	431148	3.0 CU. FT. CHEST FREEZER LID GASKET
15	490023	#1/4-28 X 1-1/4 SS FHP SCREW
16	530027	1/4-20 X 2L SS HEX SOCKET CAP SCREW
17	590020	#8-32 X 3/8 SS PHP EXT SEMS SCREW
18	3176861	1/4-20 x 3/4 SOCKET HEAD SCREW

Exploded Drawing
Model:
3 cu ft Chest
Freezer Lid (F -TS)

8700-200-1-B Rev. 1
Page 2 of 2

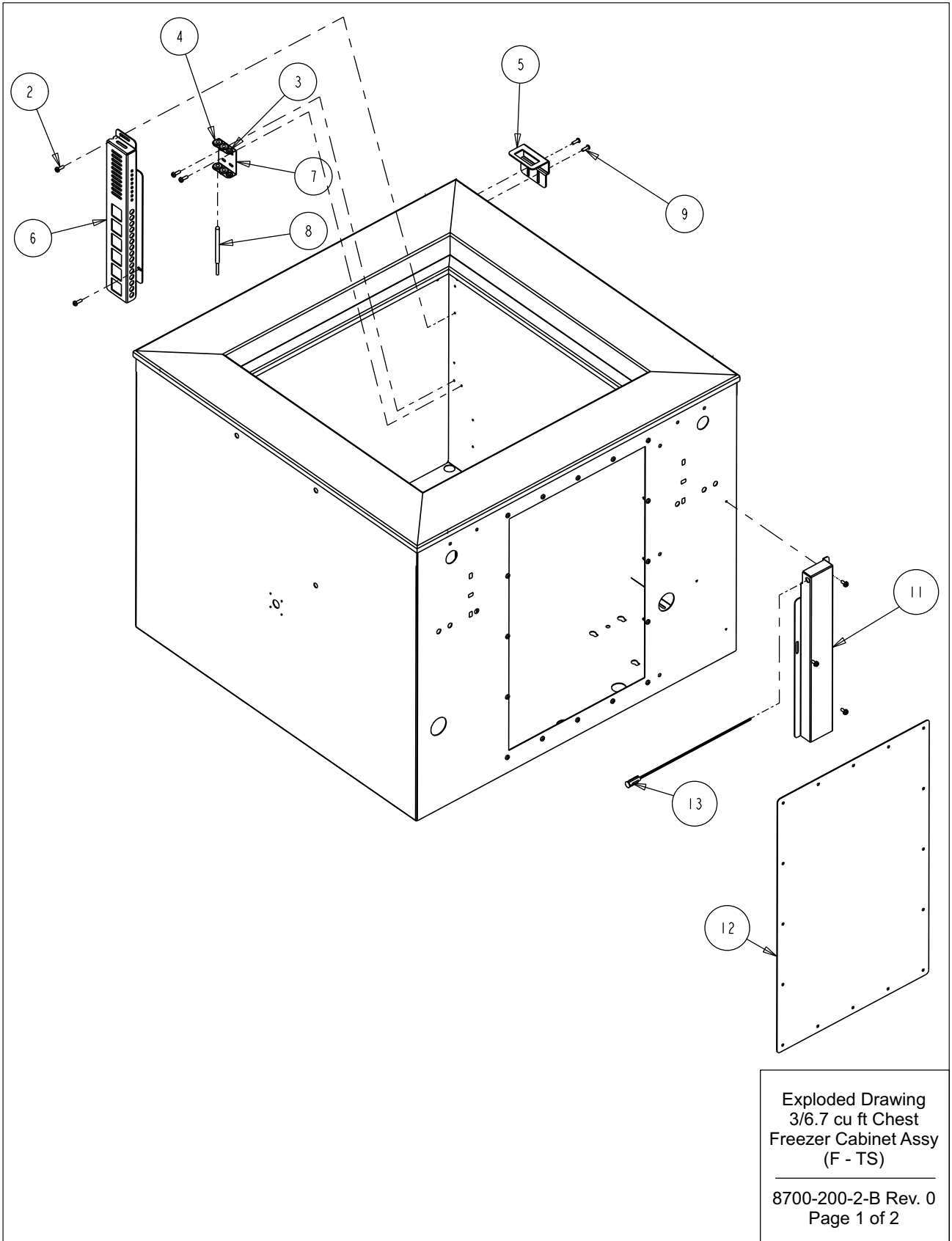

Exploded Drawing
3/6.7 cu ft Chest
Freezer Cabinet Assy
(F - TS)
8700-200-2-B Rev. 0
Page 1 of 2

Section 8
Spare Parts

BILL OF MATERIALS		
ITEM NO.	PART NO.	PART DESCRIPTION
1	24030	#8 X 1/2" TEKS SCREW
2	24042	#8-32 X 1/2 SS PHP SCREW F POINT
3	30073	5/16" X 3/16" ID GROMMET
4	114020	5/8" X 1/2" ID GROMMET
5	189526	LID LOCK MOUNT LAYOUT
6	195866	PROBE GUARD
7	195867	PROBE MOUNT
8	290176	CONTROL PROBE
9	550022	#8-32 X 1/2L BUTTON HD TORX SCREW
10	590020	#8-32 X 3/8 SS PHP EXT SEMS SCREW
11	1950371	3 C.F. CHEST LID SWITCH BRACKET
12	195622-34-1	REAR COVER PLATE
13	360230	MAGNETIC SWITCH

Exploded Drawing
3/6.7 cu ft Chest
Freezer Cabinet Assy
(F - TS)
8700-200-2-B Rev. 0
Page 2 of 2

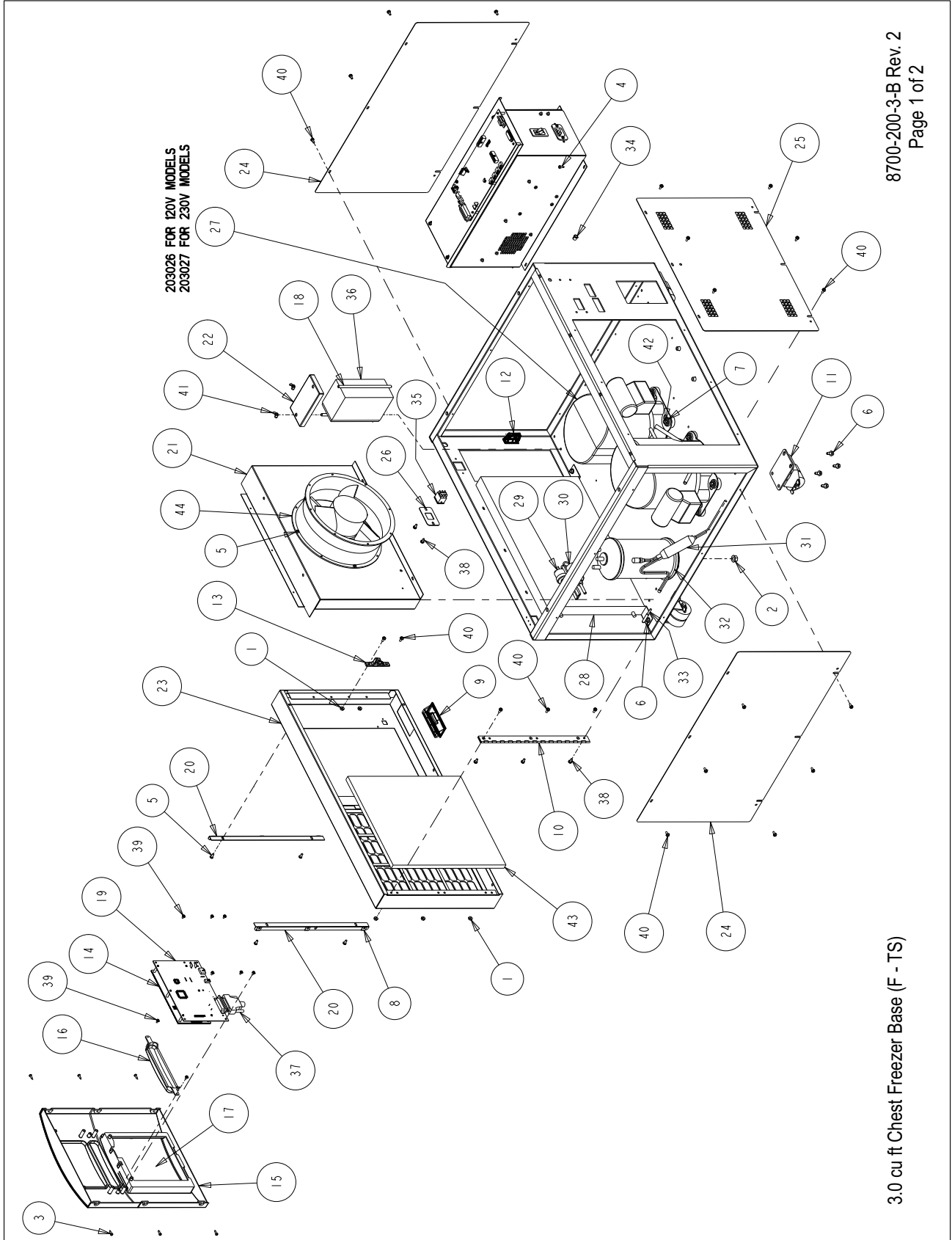

BILL OF MATERIALS	
ITEM NO.	PART NO. PART DESCRIPTION
1	23002 #8-32 ZP LKWASH HEX NUT
2	23013 3/8-16 ZP LKWASH HEX NUT
3	24016 #6 X 1/2" SS PHP SCREW AB POINT
4	24030 #8 X 1/2" TEKS SCREW
5	24032 #8-32 X 3/8 SS PHP SCREW F POINT
6	24038 1/4-20 X 1/2 SELF TAPPING SCREW
7	24049 1/4 ZP FLAT WASHER
8	25040 #6 U SPEED NUT STL. STL.
9	115032 BLACK ABS PLASTIC PULL
10	116115 FRONT PANEL HINGE
11	120011 DUAL WHEEL CASTER
12	121071 LATCH CATCH, PART OF 121071 ASSEMBLY
13	121071 LATCH KEEPER, PART OF 121071 ASSEMBLY
14	140452 CONTROL PANEL ASSEMBLY
15	180305 CONTROL CENTER DISPLAY BEZEL "SID BLU"
16	180306 THERMO BACK-UP SYSTEM BLANK PANEL "SID BLUE"
17	180308 CONTROL CENTER RECORDER BLANK "SID BLU"
18	191385 FILTER HOLD DOWN ROD
19	191953 FREEZER DISPLAY BOARD
20	195837 MOUNTING ANGLE FOR 180305
21	195923 3.0 & 6.7 CU. FT. CHEST FREEZER FAN SHROUD
22	195924 SINGLE BATTERY MOUNT BRACKET
23	195925 3.0 CU. FT. FRONT FILTER PANEL SUB-ASSEMBLY
24	195927 3.0 & 6.7 CHEST FREEZER SIDE PANEL
25	195928 3.0 CU. FT. CHEST REAR GRILLE
26	195931 3.0 & 6.7 CU. FT. BATTERY SWITCH BRACKET
27	203026 L/S & H/S COMPRESSOR 120V
28	204001 CONDENSER W/DESUPERHEATER
29	207008 PRESSURE SWITCH
30	207010 PRESSURE SWITCH

3.0 cu ft Chest Freezer Base (F - TS)

BILL OF MATERIALS	
ITEM NO.	PART NO. PART DESCRIPTION
31	209006 DRYER 1/4 OD SWEAT
32	214023 OIL SEPARATOR
33	290178 CONDENSER PROBE
34	330003 3/8" SPLIT SNAP BUSHING
35	360248 MINI SNAP-IN POWER SWITCH
36	400159 SEALED LEAD ACID BATTERY - 12 VOLT - 7.2 Ah
37	430336 15 FT, RS-232 CABLE 25 POS.
38	590020 #8-32 X 3/8 SS PHP EXT SEMS SCREW
39	590027 #6-32 X 1/4 SS PHP EXT SEMS SCREW
40	590029 #8-32 X 3/8 SS PHP EXT SEMS SCREW W/PATCH
41	610009 1/4-20 S.S. WING NUT
42	680017 1/4-20 X 1-1/4 SELF TAPPING SCREW
43	760211 3 AND 6.7 CU. FT. CHEST FREEZER AIR FILTER
44	900113 10" TUBEAXIAL FAN, 115V

8700-200-3-B Rev. 2
Page 2 of 2

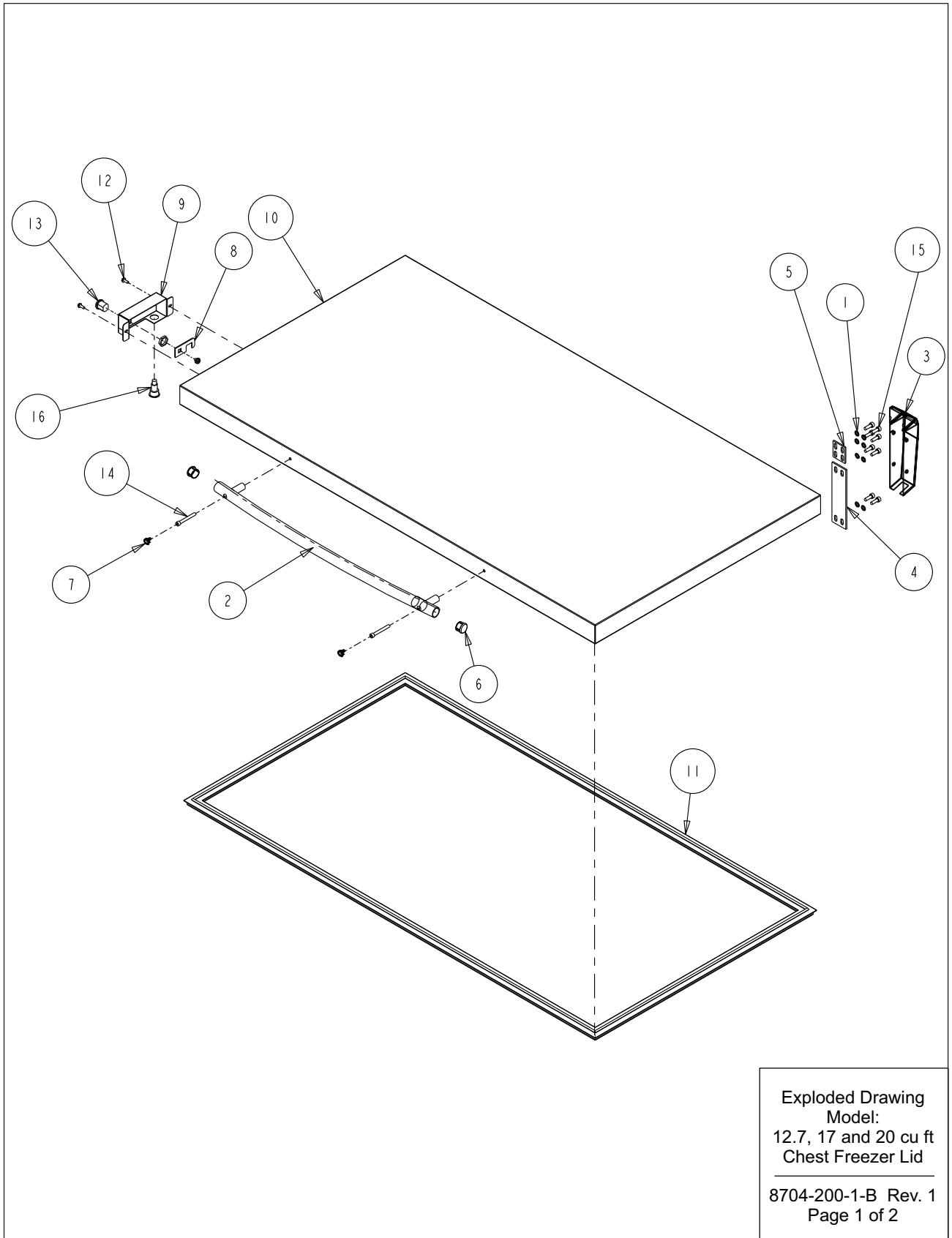

Exploded Drawing
Model:
12.7, 17 and 20 cu ft
Chest Freezer Lid
8704-200-1-B Rev. 1
Page 1 of 2

Section 8
Spare Parts

BILL OF MATERIALS		
ITEM NO.	PART NO.	PART DESCRIPTION
1	23062	1/4 SS EXT TOOTH LOCKWASHER
2	115038	646 SID BLUE RADIUSED HANDLE
3	116136	SPRING LOADED HINGE
4	116137	HINGE SHIM LAYOUT
5	116138	HINGE SHIM LAYOUT
6	180314	THERMO ULT CHEST HANDLE END CAP
7	180315	ULT CHEST HANDLE SCREW COVER
8	189529	CHEST FREEZER LOCK STRIKE
9	195935	CHEST FREEZER LOCK MOUNT
10	195958	12.7 CU. FT. CHEST FREEZER LID
11	431133	12.7 CU. FT. CHEST FREEZER LID GASKET
12	510022	#10-32 X 1/2" LONG SLOTTED HEX HEAD SCREW
13	515070	PANEL MOUNT TUMBLER LOCK
14	530027	1/4-20 X 2L SS HEX SOCKET CAP SCREW
15	3176861	1/4-20 x 3/4 SOCKET HEAD SCREW
16	360256	MAGNETIC SWITCH MAGNET

FOR 17 CU. FT. MODELS - USE PART 195957 LID AND PART 990036 GASKET
 FOR 20 CU. FT. MODELS - USE PART 195956 LID AND PART 431132 GASKET

Exploded Drawing
 Model:
 12.7, 17 and 20 cu ft
 Chest Freezer Lid

8704-200-1-B Rev. 1
 Page 2 of 2

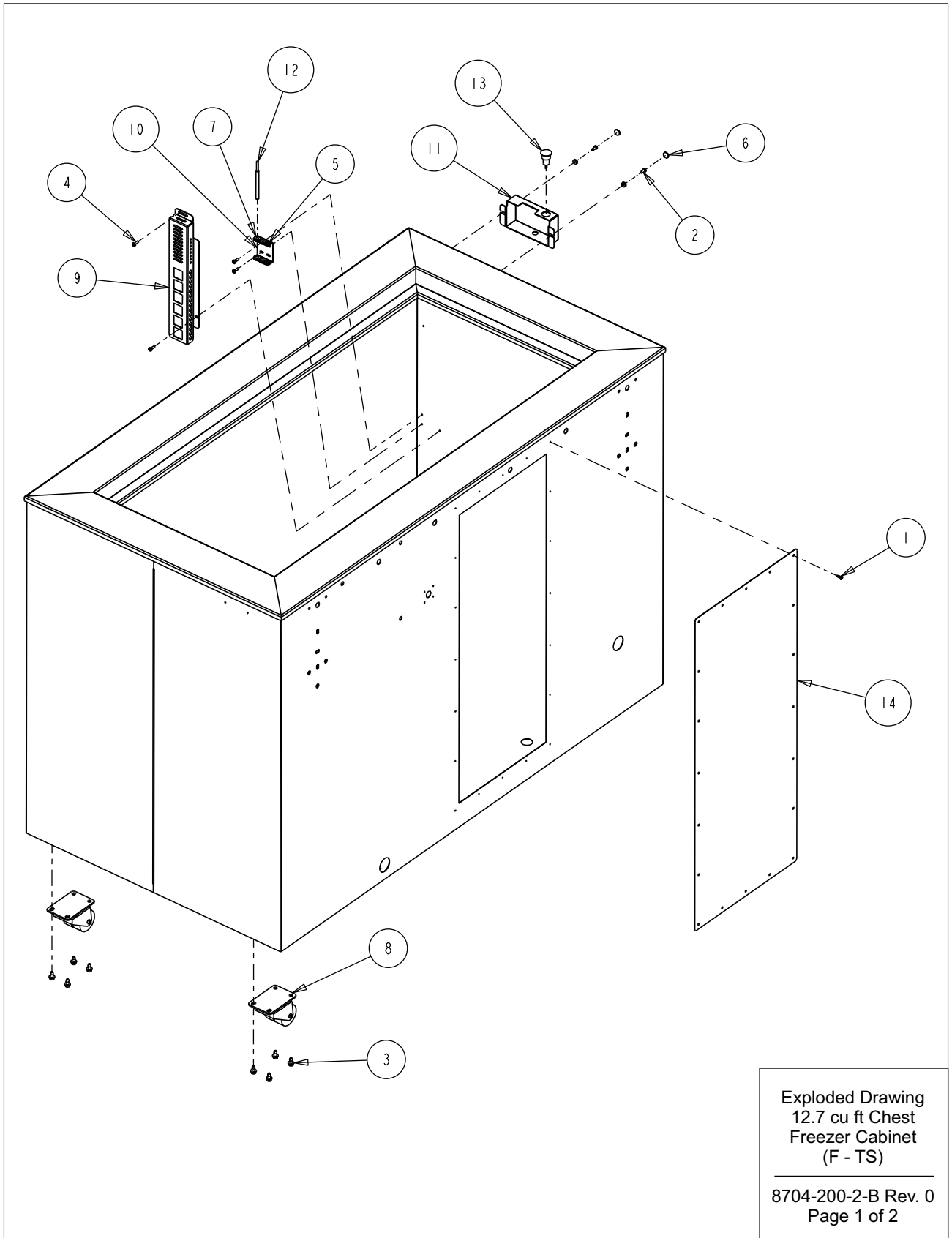

Section 8
Spare Parts

BILL OF MATERIALS		
ITEM NO.	PART NO.	PART DESCRIPTION
1	24030	#8 X 1/2" TEKS SCREW
2	24032	#8-32 X 3/8 SS PHP SCREW F POINT
3	24038	1/4-20 X 1/2 SELF TAPPING SCREW
4	24042	#8-32 X 1/2 SS PHP SCREW F POINT
5	30073	5/16" X 3/16" ID GROMMET
6	110028	DECORATIVE SNAP CAP
7	114020	5/8" X 1/2" ID GROMMET
8	120011	DUAL WHEEL CASTER
9	195866	PROBE GUARD
10	195867	PROBE MOUNT
11	195936	LOCK CATCH
12	290176	CONTROL PROBE
13	360256	MAGNETIC SWITCH
14	195478-39-1	REAR COVER PLATE

Exploded Drawing
12.7 cu ft Chest
Freezer Cabinet
(F - TS)

8704-200-2-B Rev. 0
Page 2 of 2

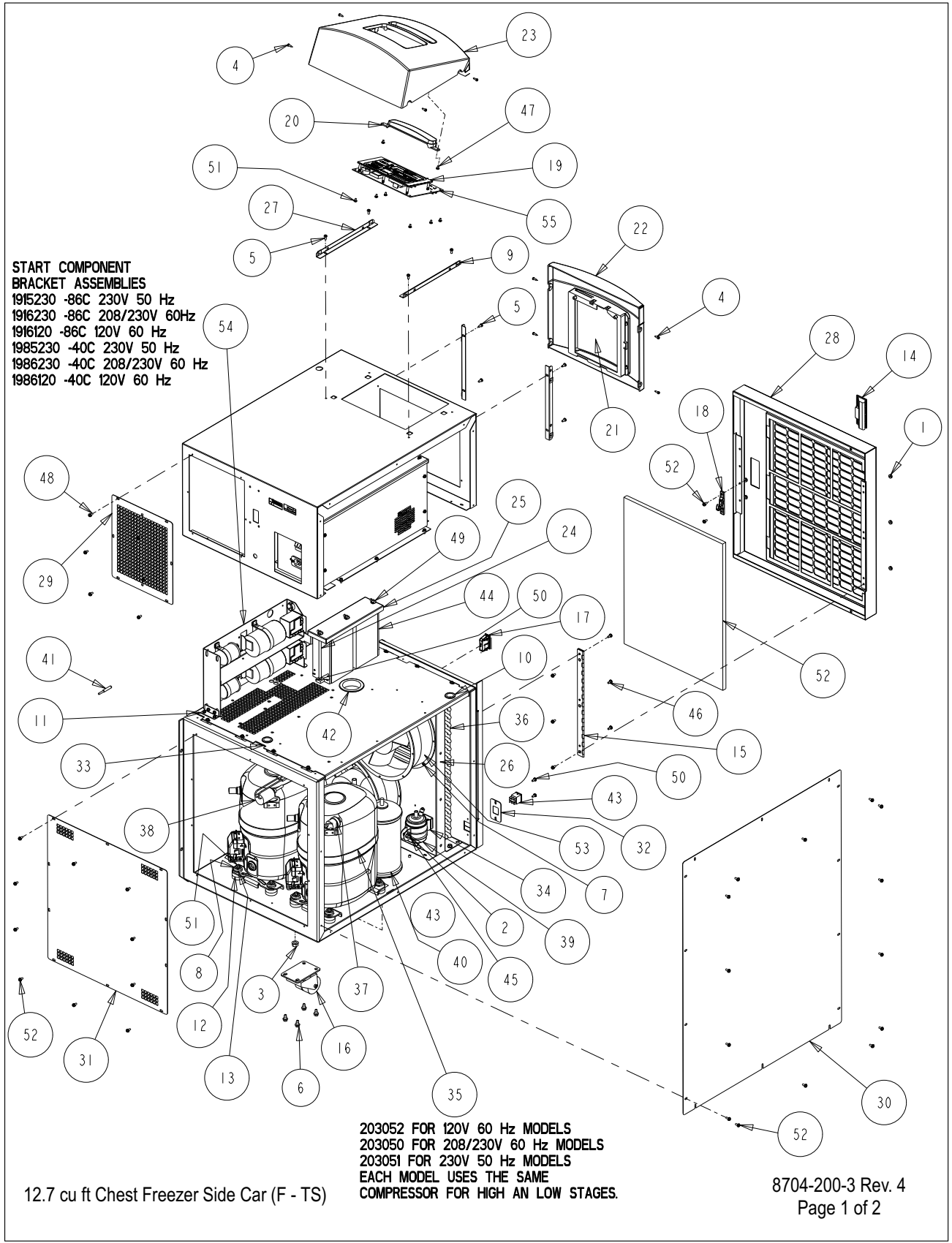

12.7 cu ft Chest Freezer Side Car (F - TS)

Section 8
Spare Parts

			BILL OF MATERIALS	
ITEM NO.	PART NO.	PART DESCRIPTION		
	1	23002	#8-32 ZP LKWASH HEX NUT	
	2	23011	1/4-20 ZP LKWASH HEX NUT	
	3	23013	3/8-16 ZP LKWASH HEX NUT	
	4	24016	#6 X 1/2" SS PHP SCREW AB POINT	
	5	24032	#8-32 X 3/8 SS PHP SCREW F POINT	
	6	24038	1/4-20 X 1/2 SELF TAPPING SCREW	
	7	24042	#8-32 X 1/2 SS PHP SCREW F POINT	
	8	24049	1/4 ZP FLAT WASHER	
	9	25040	#6 U SPEED NUT STL. STL.	
	10	30016	1" SNAP BUSHING	
	11	111047	COMPONENT ASSEMBLY HOLD DOWN BRACKET	
	12	114033	COMPRESSOR MOUNTING FOOT	
	13	114034	COMPRESSOR MOUNTING SLEEVE	
	14	115032	BLACK ABS PLASTIC PULL	
	15	116115	FRONT PANEL HINGE	
	16	120011	DUAL WHEEL CASTER	
	17	121071	LATCH CATCH, PART OF 121071 ASSEMBLY	
	18	121071	LATCH KEEPER, PART OF 121071 ASSEMBLY	
	19	140452	CONTROL PANEL ASSEMBLY	
	20	180306	THERMO BACK-UP SYSTEM BLANK PANEL "SID BLUE"	
	21	180308	CONTROL CENTER RECORDER BLANK "SID BLU"	
	22	180311	THERMO SIDE CAR RECORDER BEZEL	
	23	180327	THERMO CHEST CONTROL CENTER BEZEL	
	24	191385	FILTER HOLD DOWN ROD	
	25	195768	BATTERY MOUNT TOP	
	26	195782	CHEST FREEZER FAN SHROUD	
	27	195783	CHEST FREEZER CONTROL PANEL MOUNTING ANGLE	
	28	195791	CHEST FREEZER FRONT PANEL ASSEMBLY	
	29	195806	CHEST FREEZER REAR ACCESS PANEL	
	30	195807	CHEST FREEZER SIDE CAR SIDE COVER	
	31	195808	CHEST FREEZER SIDE CAR REAR PANEL	
	32	195931	3.0 & 6.7 CU. FT. BATTERY SWITCH BRACKET	
	33	195949	CHEST FREEZER SIDE CAR DIVIDER	
34	200126	2" RIGID HANGER		
35	203050	BRISTOL HIGH/LOW STAGE COMPRESSOR		
36	204010	CONDENSER W/DESUPERHEATER		
37	207008	PRESSURE SWITCH		
38	207010	PRESSURE SWITCH		
39	209020	LIQUID LINE FILTER DRYER WITH ACCESS PORT		
40	214023	OIL SEPARATOR		
41	290178	CONDENSER PROBE		
42	330039	2-1/2" SNAP BUSHING		
43	360248	MINI SNAP-IN POWER SWITCH		
44	400159	SEALED LEAD ACID BATTERY - 12 VOLT - 7.2 Ah		
45	550043	1/4-20 X 1" L ZP CARRIAGE BOLT		
46	590020	#8-32 X 3/8 SS PHP EXT SEMS SCREW		
47	590027	#6-32 X 1/4 SS PHP EXT SEMS SCREW		
48	590029	#8-32 X 3/8 SS PHP EXT SEMS SCREW W/PATCH		
49	610009	1/4-20 S.S. WING NUT		
50	610078	1/4-20 NUT RETAINER (.025-.063 PANEL)		
51	680008	1/4-20 X 1-3/4 SELF TAPPING SCREW		
52	760212	12, 17 AND 20 CU. FT. CHEST AIR FILTER		
53	900113	10" TUBEAXIAL FAN, 115V		
54	120230-01-1	CHEST FREEZER START COMPONENT BRACKET ASSEMBLY		
55	191953_	FREEZER DISPLAY BOARD		

12.7 cu ft Chest Freezer Side Car (F - TS)

8704-200-3 Rev. 4
Page 2 of 2

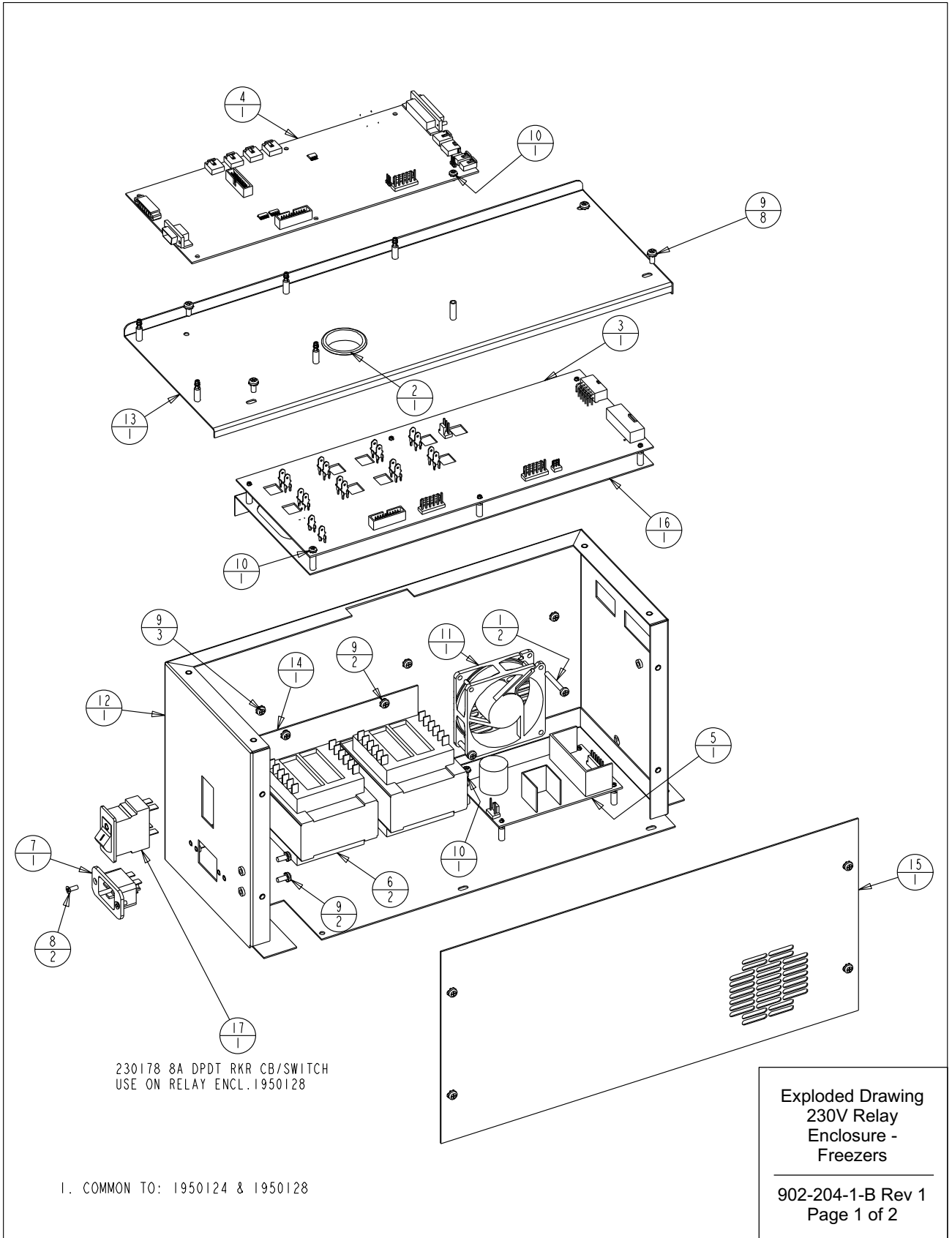

Section 8
Spare Parts

REV	ECN NO.	DATE	BY	CAD	APPD	DESCRIPTION OF REVISION
0	FR-2202	06-23-11	KDG	KDG	DRP	RELEASED FOR PRODUCTION / REL. 6
1	FR-2409	10-10-12	AJC	KDG	CCS	REMOVED 1950122 & 1950126 LOW END BOXES

BILL OF MATERIALS		
ITEM NO.	PART NO.	PART DESCRIPTION
1	22143	#8-32 x 1-1/4 SS PHP SCREW
2	30077	1-1/2" SNAP BUSHING
3	191923	HIGH VOLTAGE BOARD 230V
4	191989	MICRO BOARD (HIGH END)
5	400165	SWITCHER BOARD
6	420090	175V TRANSFORMER
7	460169	POWER INLET, 16/20A
8	490009	#6-32 X 3/8 SS FHP UC SCREW
9	590020	#8-32 X 3/8 SS PHP EXT SEMS SCREW
10	590027	#6-32 X 1/4 SS PHP EXT SEMS SCREW
11	900134	TUBEAXIAL FAN, 30 CFM, 12V
12	195631-16-1	RELAY ENCLOSURE SPOTWELD SUB-ASSEMBLY
13	195631-16-4	RELAY ENCLOSURE COVER/191656 SUPPORT
14	195631-31-3	TRANSFORMER HOLD DOWN
15	195631-31-5	RELAY ENCLOSURE COVER (MAIN)
16	195730-16-1	191658 SUPPORT BRACKET SUB-ASSEMBLY
17	230184	15A DPDT SWITCH/CIRCUIT BKR

THIS DOCUMENT CONTAINS PROPRIETARY INFORMATION AND SUCH INFORMATION IS NOT TO BE DISCLOSED TO OTHERS FOR ANY PURPOSE NOR USED FOR MANUFACTURING PURPOSE WITHOUT WRITTEN PERMISSION FROM THERMO FISHER SCIENTIFIC

ThermoFisher
SCIENTIFIC

BOX 649, MARIETTA, OHIO 45750

MODEL/PART NAME: RELAY ENCLOSURE ASSEMBLY

DWG TITLE: 230 VOLT RELAY ENCLOSURE ASSY

DWN: KDG CAD: KDG APPD: DRP DATE: 06-23-11 SCALE: 0.250

MATERIAL: -

PAINT: N/A

TOLERANCE UNLESS OTHERWISE SPECIFIED
 ANGLES: DECIMAL: .XX=±
 .xxx=±

DRAWING NUMBER

902-204-1

SIZE

B

Exploded Drawing
230V Relay
Enclosure -
Freezers

902-204-1-B Rev 1
Page 2 of 2

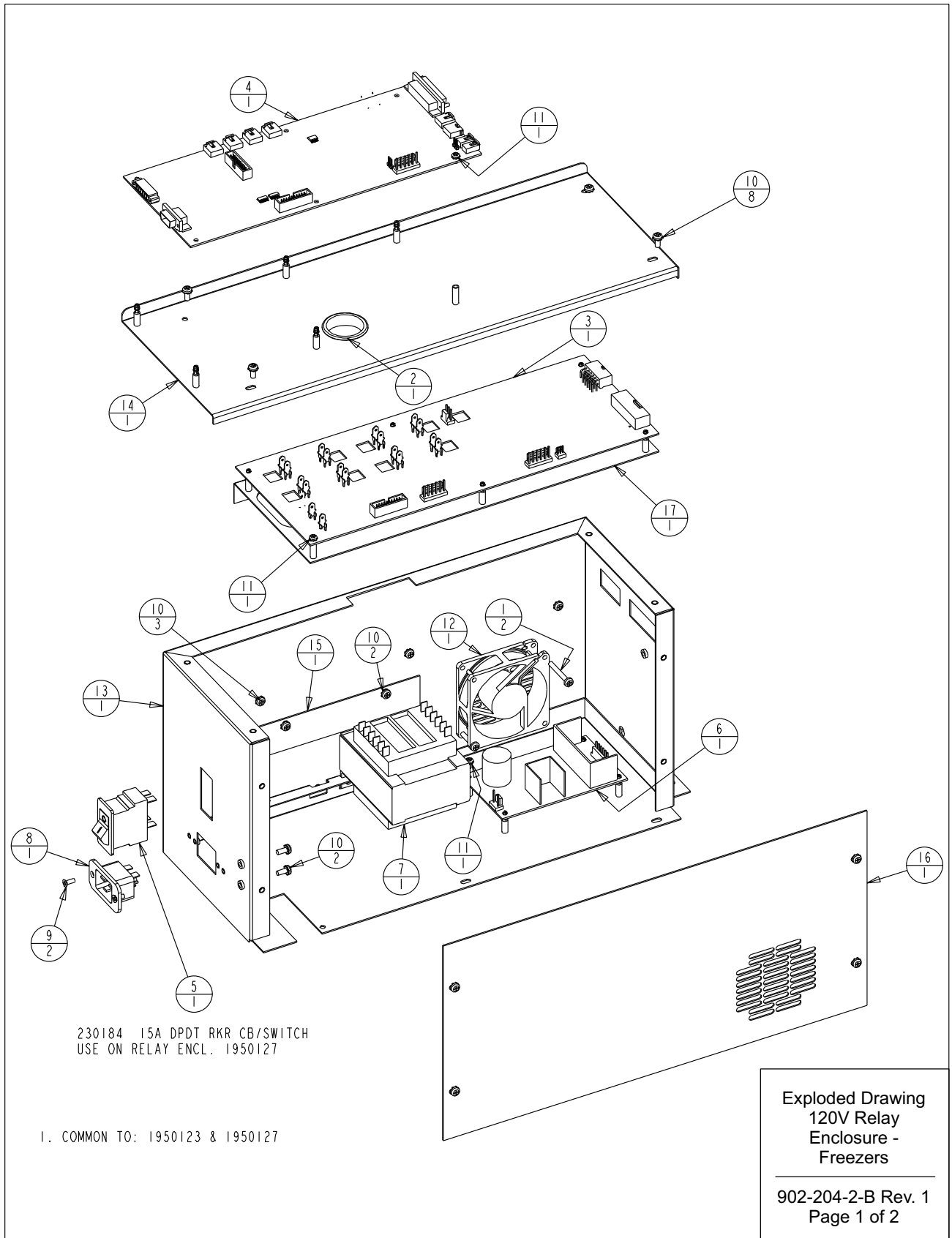

Section 8
Spare Parts

REV	ECN NO.	DATE	BY	CAD	APPD	DESCRIPTION OF REVISION
0	FR-2202	06-23-11	KDG	KDG	DRP	RELEASED FOR PRODUCTION / REL. 6
1	FR-2409	10-10-12	AJC	KDG	CCS	REMOVED 1950121 & 1950125 LOW END BOXES

BILL OF MATERIALS		
ITEM NO.	PART NO.	PART DESCRIPTION
1	22143	#8-32 x 1-1/4 SS PHP SCREW
2	30077	1-1/2" SNAP BUSHING
3	191932	HIGH VOLTAGE BOARD 120V
4	191989	MICRO BOARD (HIGH END)
5	230183	20A DPDT SWITCH/CIRCUIT BKR
6	400165	SWITCHER BOARD
7	420065	175V TRANSFORMER
8	460169	POWER INLET, 16/20A
9	490009	#6-32 X 3/8 SS FHP UC SCREW
10	590020	#8-32 X 3/8 SS PHP EXT SEMS SCREW
11	590027	#6-32 X 1/4 SS PHP EXT SEMS SCREW
12	900134	TUBEAXIAL FAN, 30 CFM, 12V
13	195631-16-1	RELAY ENCLOSURE SPOTWELD SUB-ASSEMBLY
14	195631-16-4	RELAY ENCLOSURE COVER/191656 SUPPORT
15	195631-31-3	TRANSFORMER HOLD DOWN
16	195631-31-5	RELAY ENCLOSURE COVER (MAIN)
17	195730-16-1	191658 SUPPORT BRACKET SUB-ASSEMBLY

THIS DOCUMENT CONTAINS PROPRIETARY INFORMATION AND SUCH INFORMATION IS NOT TO BE DISCLOSED TO OTHERS FOR ANY PURPOSE NOR USED FOR MANUFACTURING PURPOSE WITHOUT WRITTEN PERMISSION FROM THERMO FISHER SCIENTIFIC

ThermoFisher
SCIENTIFIC

BOX 649, MARIETTA, OHIO 45750

MODEL/PART NAME: RELAY ENCLOSURE ASSEMBLY

DWG TITLE: 120 VOLT RELAY ENCLOSURE ASSY

DWN: KDG CAD: KDG APPD: DRP DATE: 06-23-11 SCALE: 0.250

MATERIAL: -

PAINT: N/A

TOLERANCE UNLESS OTHERWISE SPECIFIED
ANGLES: DECIMAL: .XX=±
 .xxx=±

DRAWING NUMBER

902-204-2

SIZE

B

Exploded Drawing
120V Relay
Enclosure -
Freezers

902-204-2-B Rev. 1
Page 2 of 2

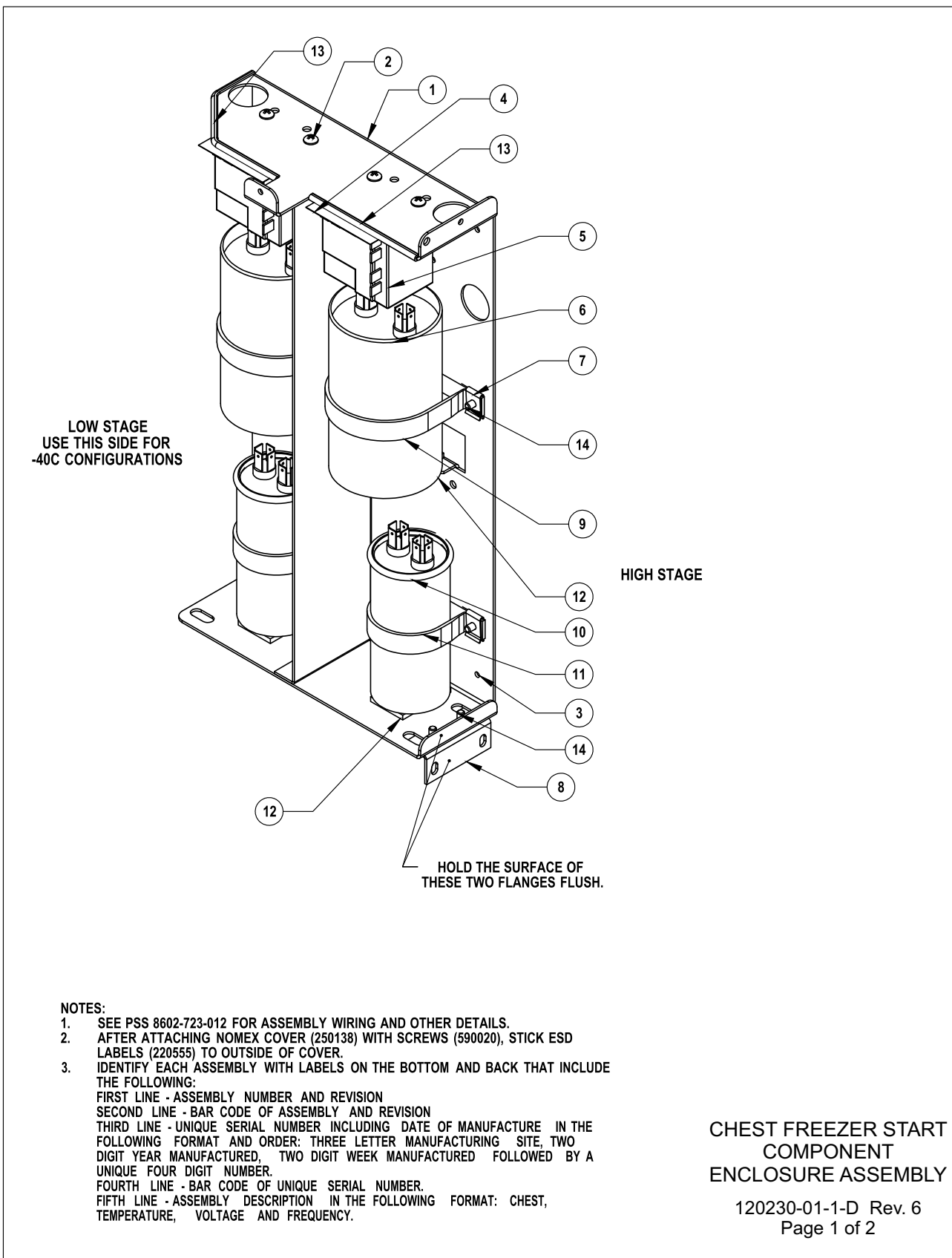

Section 8
Spare Parts

CHEST FREEZER START COMPONENT BRACKET ASSEMBLIES								
ITEM NO.	DESCRIPTION	1915230 -86C 230V 50 Hz	1916230 -86C 208/230V 60Hz	1916120 -86C 120V 60 Hz	1985230 -40C 230V 50 Hz	1986230 -40C 208/230V 60 Hz	1986120 -40C 120V 60 Hz	
1	COMPONENT BRACKET	120230	120230	120230	120230	120230	120230	
2	#8 X 1/2 PHP TYPE B	680013 (4)	680013 (4)	680013 (4)	680013 (2)	680013 (2)	680013 (2)	
3	8-32 X 3/8 SCREW	590020 (2)	590020 (2)	590020 (2)	590020 (2)	590020 (2)	590020 (2)	
4	NOMEX INSULATOR	270172 (2)	270172 (2)	270172 (2)	270172 (1)	270172 (1)	270172 (1)	
5	START RELAY	300430 (2)	312188 (2)	300428 (2)	300430 (1)	312188 (1)	300428 (1)	
6	START CAPACITOR	170154 (2)	170154 (2)	170154 (2)	170154 (1)	170154 (1)	170154 (1)	
7	#8 SPEED NUT, S.S.	327675 (4)	327675 (4)	327675 (4)	327675 (2)	327675 (2)	327675 (2)	
8	HOLD DOWN BRACKET	111047	111047	111047	111047	111047	111047	
9	2.5" VINYL COATED STRAP	600106 (2)	600106 (2)	600106 (2)	600106 (1)	600106 (1)	600106 (1)	
10	RUN CAPACITOR	170097 (2)	170226 (2)	170224 (2)	170097 (1)	170226 (1)	170224 (1)	
11	1.75" VINYL COATED STRAP	600107 (2)	600107 (2)	600107 (2)	600107 (1)	600107 (1)	600107 (1)	
12	NEOPRENE TAPE 1/8" X 1" X 2"	28003 (4)	28003 (4)	28003 (4)	28003 (2)	28003 (2)	28003 (2)	
13	EDGE GUARD (CUT TO LENGTH)	114012	114012	114012	114012	114012	114012	
14	#8 X 1/2 PHP TYPE AB	24021 (6)	24021 (6)	24021 (6)	24021 (4)	24021 (4)	24021 (4)	
NOT SHOWN *	15	ULT MAIN HARNESS (REFERENCE ONLY)	350082	350082	350082	350109	350109	350109
NOT SHOWN	16	ENCLOSURE LOW STAGE HARNESS	350108	350108	350108	350108	350108	350108
NOT SHOWN	17	ENCLOSURE HIGH STAGE HARNESS	350107	350107	350107	N/A	N/A	N/A
NOT SHOWN	18	NOMEX COVER	250138	250138	250138	250138	250138	250138
NOT SHOWN	19	ESD CAUTION LABEL	220555 (2)	220555 (2)	220555 (2)	220555 (2)	220555 (2)	220555 (2)
NOT SHOWN, SEE NOTE 3	20	IDENTIFICATION LABEL	723050	723060	712060	123050	123060	112060

* THE ULT MAIN HARNESS IS LISTED FOR INFORMATION ONLY. IT IS NOT PART OF THIS ASSEMBLY.

CHEST FREEZER START COMPONENT
ENCLOSURE ASSEMBLY

120230-01-1-D Rev. 6
Page 2 of 2

CASCADE REFRIGERATION

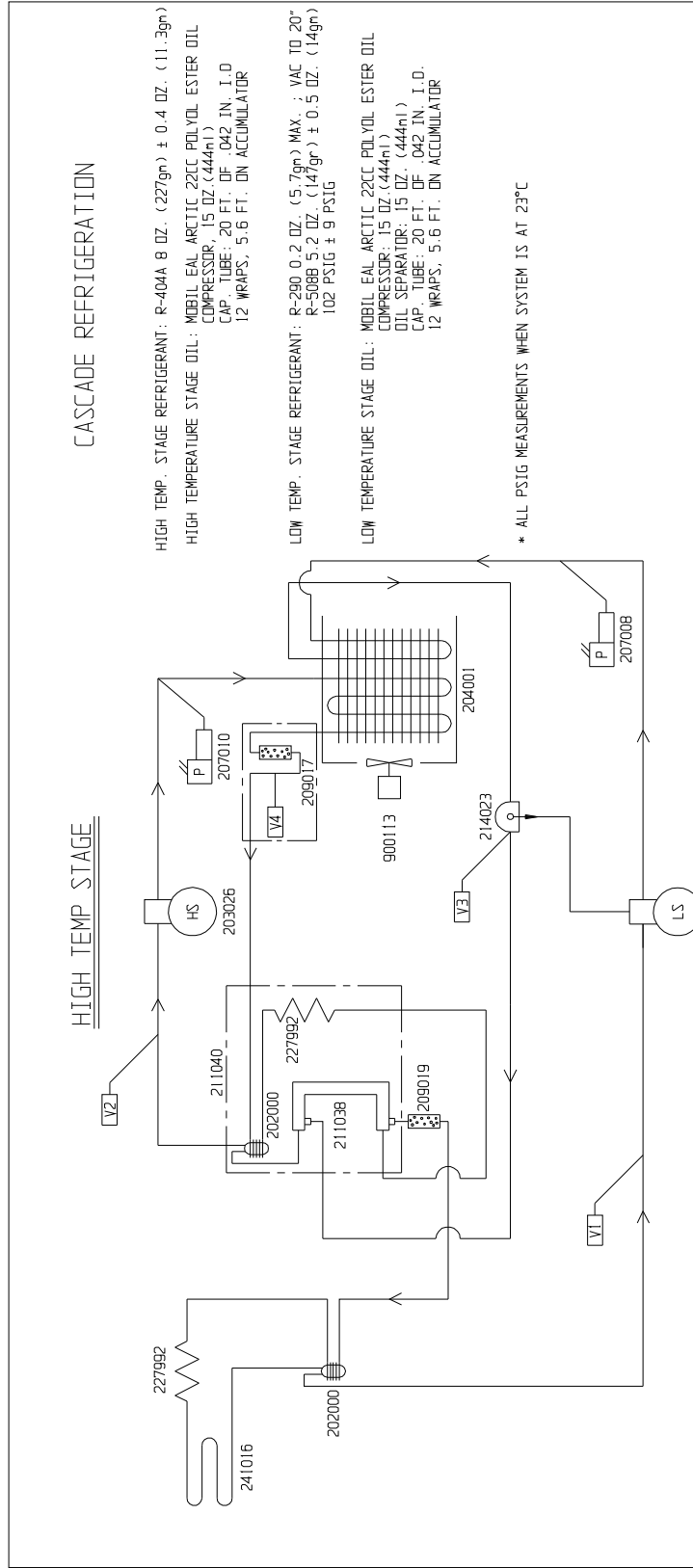

HIGH TEMP. STAGE REFRIGERANT: R-404A 8 OZ. (227gm) ± 0.4 OZ. (11.3gm)
 HIGH TEMPERATURE STAGE OIL: MOBIL EAL ARCTIC 22CC POLYOL ESTER OIL
 COMPRESSOR: 15 OZ. (444gm)
 CAP. TUBE: 20 FT. OF .042 IN. I.D.
 12 WRAPS, 5.6 FT. DN ACCUMULATOR

LOW TEMP. STAGE REFRIGERANT: R-290 0.2 OZ. (5.7gm) MAX. ; VAC TO 20"
 R-508B 5.2 OZ. (147gr) ± 0.5 OZ. (14gm)
 102 PSIG ± 9 PSIG

LOW TEMPERATURE STAGE OIL: MOBIL EAL ARCTIC 22CC POLYOL ESTER OIL
 COMPRESSOR: 15 OZ. (444gm)
 OIL SEPARATOR: 15 OZ. (444gm)
 CAP. TUBE: 20 FT. OF .042 IN. I.D.
 12 WRAPS, 5.6 FT. DN ACCUMULATOR

* ALL PSIG MEASUREMENTS WHEN SYSTEM IS AT 23°C

2	FR-2577	06-05-14	SAG	CCS	209017	MS	209006	R-404A	MS	7	OZ.
1	FR-2673	06-04-14	MM	KCG	DRP	CHANGED	214006	OIL	SEP.	TO	214023
0	FR-2202	05/11/11	SRS	SAG	DRP	RELEASED	FOR	PRODUCTION	RELEASE	6	
REV	ECR	NO.	DATE	BY	[CAD]	APPD	DESCRIPTION	OF	REVISION		
DATE	05/05/11	DOWN	SAG	[CAD]	SAG	APPD	DRP	SCALE	NONE		
CUSTOMER											
JOB TITLE	-86°C 3 CU. FT. CHEST FREEZERS (120 V)										
DWG TITLE	REFRIGERATION SCHEMATIC										
LOCATION	JOB NUMBER										DRAWING NUMBER
											8700-90-0-B

THIS DOCUMENT CONTAINS PROPRIETARY INFORMATION AND SUCH INFORMATION IS NOT TO BE DISCLOSED TO OTHERS FOR ANY PURPOSE WITHOUT THE WRITTEN PERMISSION FROM THERMO FISHER SCIENTIFIC

ThermoFisher
SCIENTIFIC
 BOX 649, MARIETTA, OHIO 45750

1. COMMON TD: 5708, 5608, 5808, 5150, 8700, 8739 & 8763 3 CU.FT. FREEZERS (120 V)

LOW TEMP STAGE

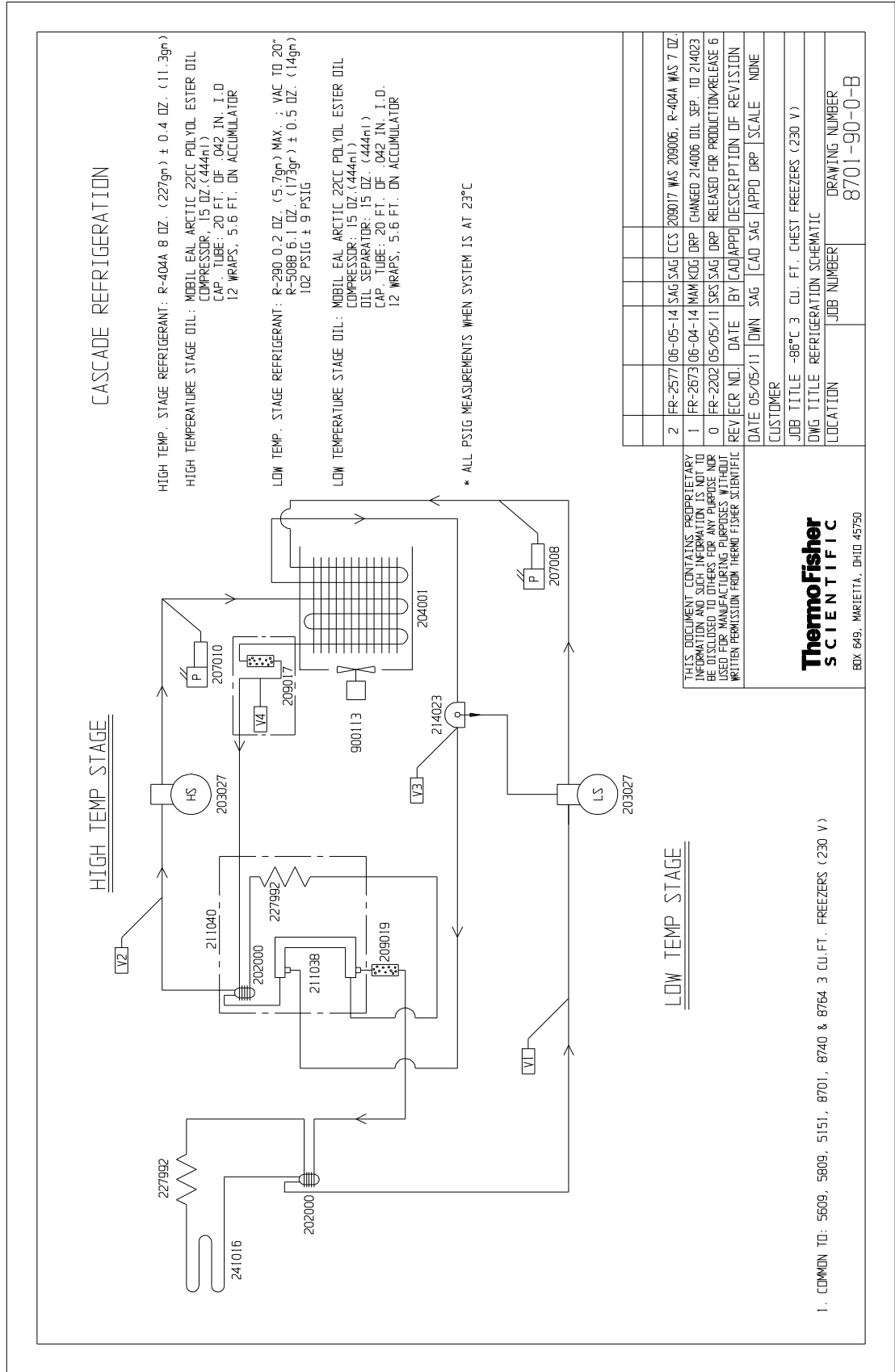

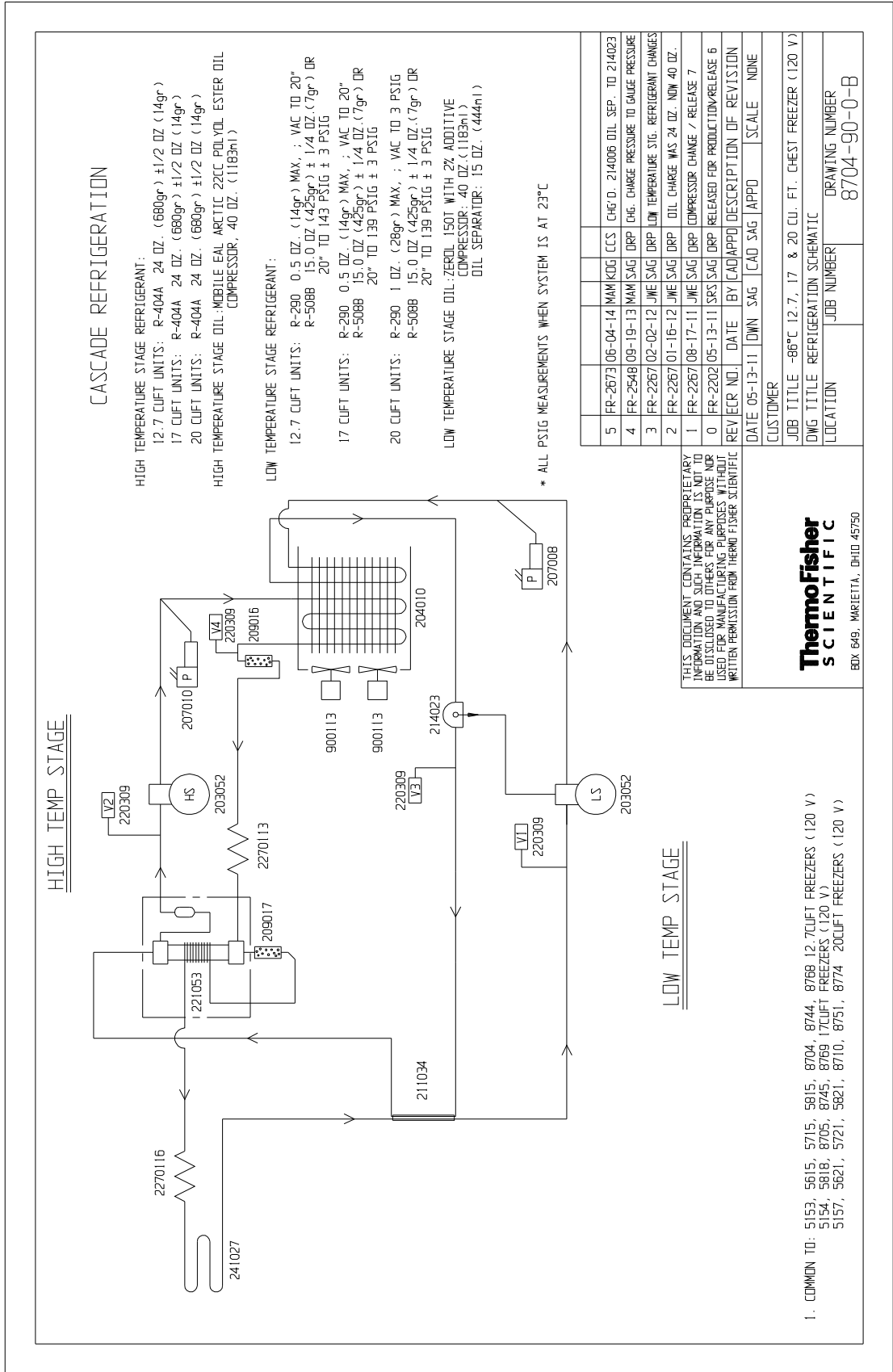

DRAWING NUMBER: 8717-90-0-B

REV	ECN NO.	DATE	BY	APPD	DESCRIPTION OF REVISION
0	FR-2002	05/11/11	SRP	SAG	RELEASE FOR PRODUCTION/RELEASE 6
1	FR-2673	06-04-14	MM	KOG	DRP CHANGE 214006 OIL SEP. TO 214023
2	FR-2577	06-05-14	SAG	CCS	209017 WAS 209006. CHANGED R-404A

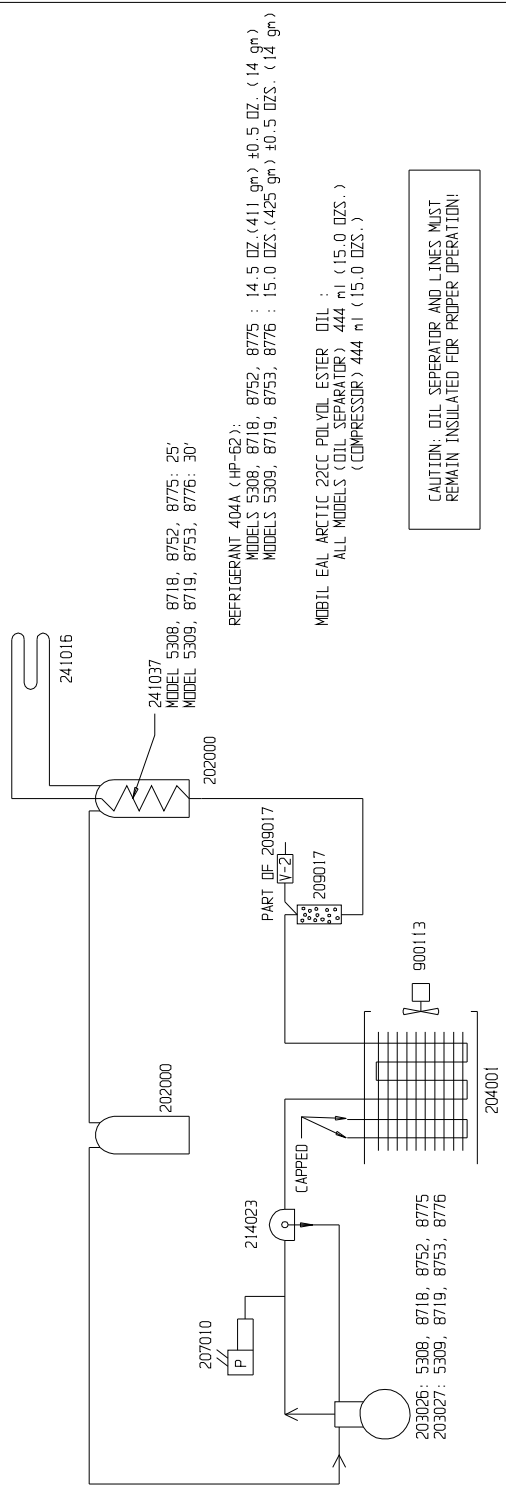

CAUTION: OIL SEPARATOR AND LINES MUST REMAIN INSULATED FOR PROPER OPERATION!

THIS DOCUMENT CONTAINS PROPRIETARY INFORMATION AND SUCH INFORMATION IS NOT TO BE DISCLOSED TO OTHERS FOR ANY PURPOSE NOR USED FOR MANUFACTURING PURPOSES WITHOUT WRITTEN PERMISSION FROM THERMO FISHER SCIENTIFIC	
MODEL/PART NAME: -40°C 3 CU. FT. FREEZERS, 120V & 230V	DWG TITLE: REFRIGERATION SCHEMATIC
UNV: GLS	APPD: DRP
DATE: 6-18-09	SCALE: NONE
MATERIAL:	
PAINT COLOR:	
TOLERANCE UNLESS OTHERWISE SPECIFIED	DRAWING NUMBER
ANGLES: .XX±	8718-90-0
.XXX±	SIZE
	B

ThermoFisher
SCIENTIFIC
BOX 649, MARIETTA, OHIO 45750

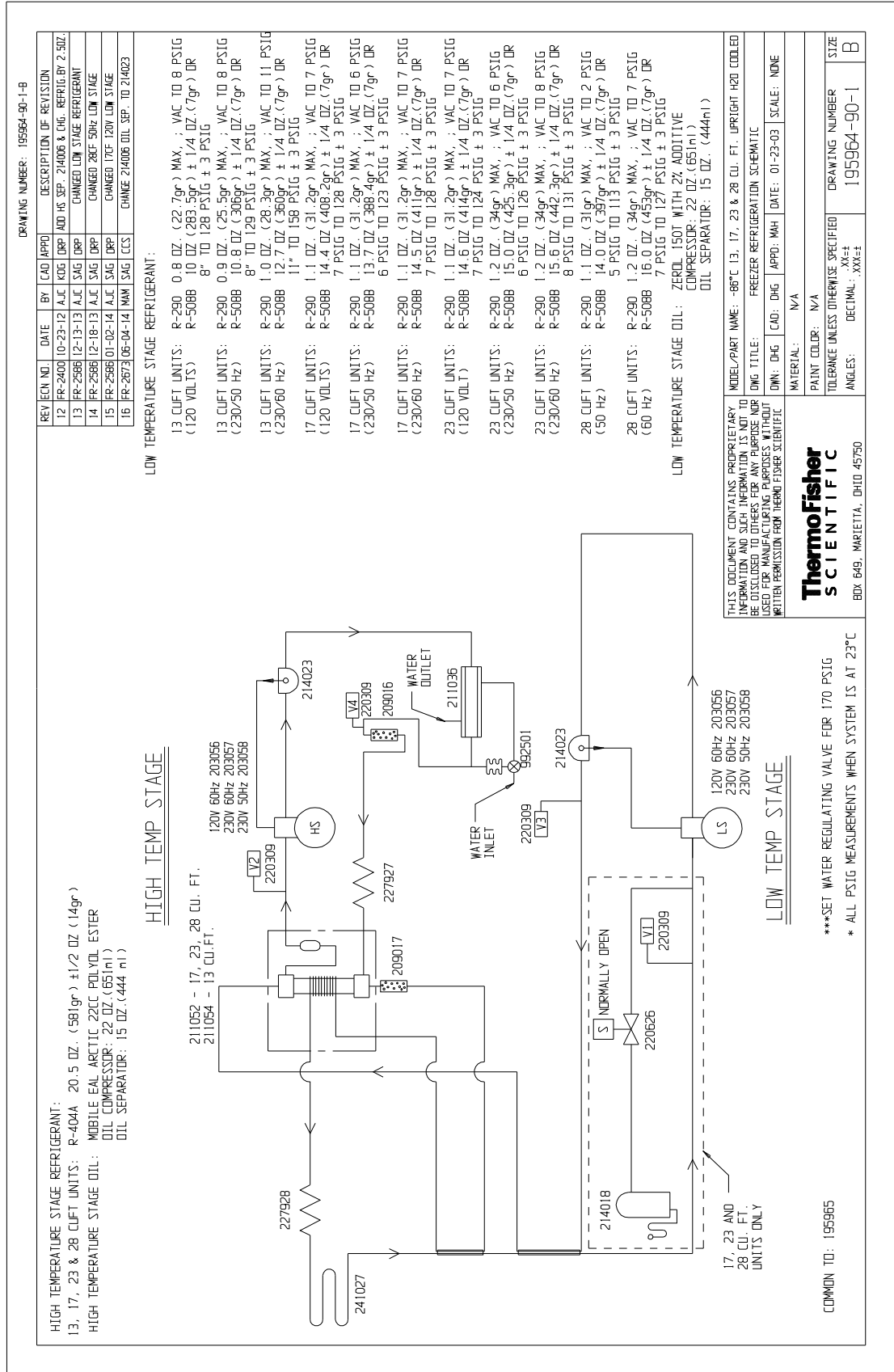

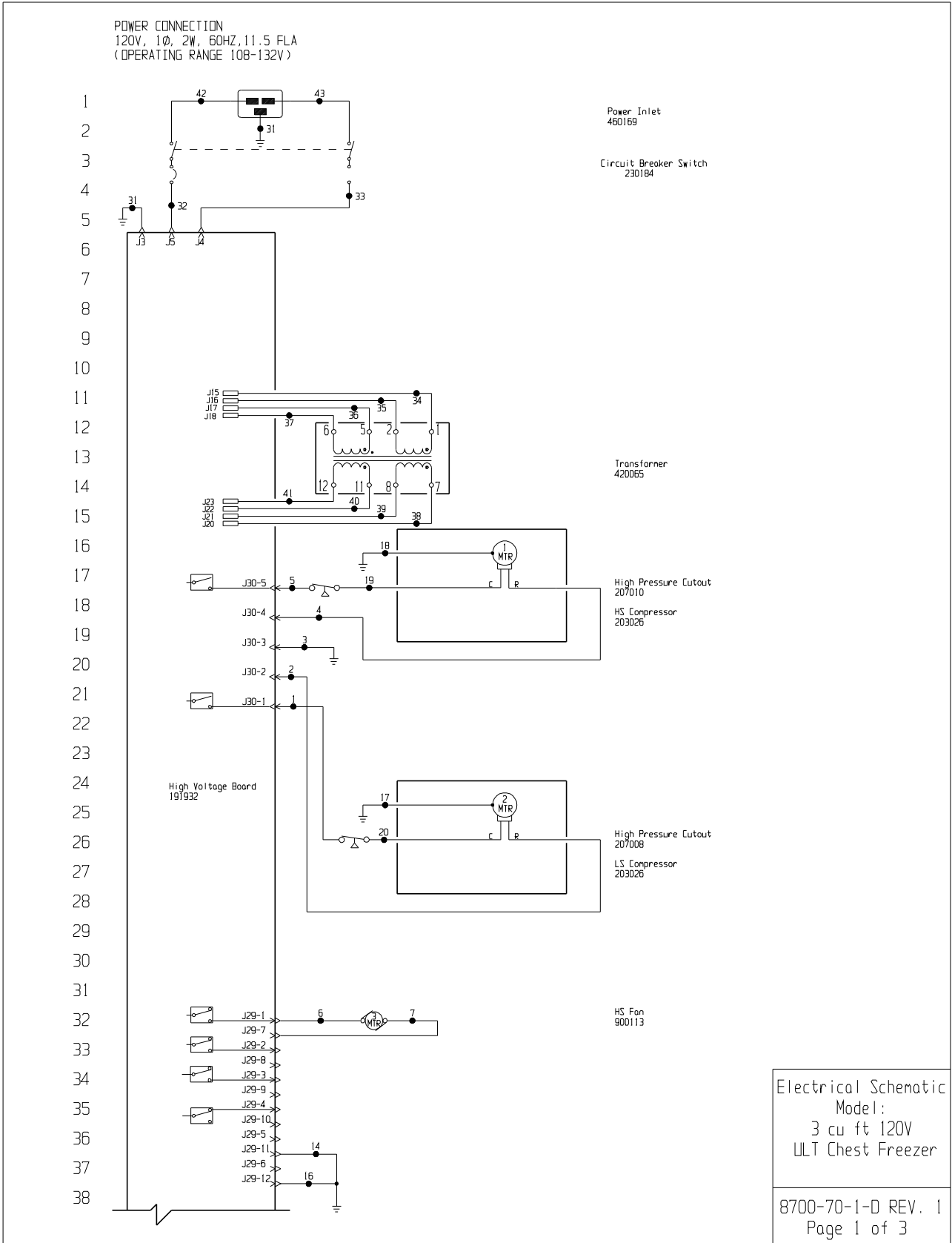

Section 10
Electrical Schematics

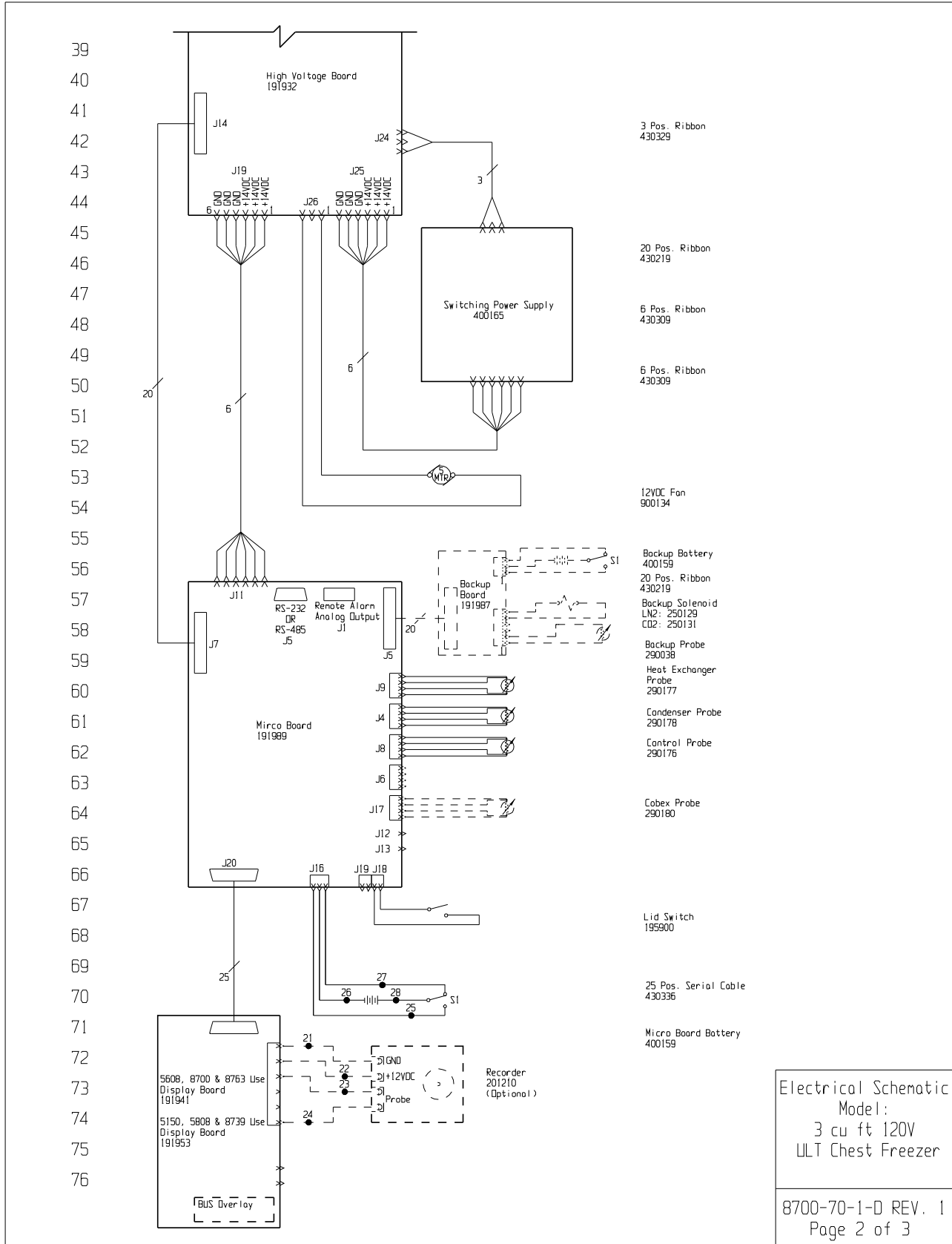

Electrical Schematic
Model:
3 cu ft 120V
ULT Chest Freezer

8700-70-1-D REV. 1
Page 2 of 3

	WIRE #	COLOR	GAUGE	WIRE #	COLOR	GAUGE
77	1	BLK	14	25	WHT	18
	2	RED	14	26	BLK	18
78	3	GRN/YEL	14	27	BLK	18
	4	RED	14	28	RED	18
79	5	BLK	14	29		
	6	BLK	18	30		
80	7	BLK	18	31	GRN/YEL	14
	8			32	BLK	14
81	9			33	BLU	14
	10			34	BLK	14
82	11			35	BLU	14
	12			36	BLK	14
83	13			37	BLU	14
	14	GRN/YEL	18	38	BLK	14
84	15			39	BLU	14
	16	GRN/YEL	18	40	BLK	14
	17	GRN/YEL	14	41	BLU	14
85	18	GRN/YEL	14	42	BLK	14
	19	BLK	14	43	BLU	14
86	20	BLK	14			
	21	BLK	18			
87	22	RED	18			
	23	BLK	18			
88	24	RED	18			

3 CU.FT. CHEST MODELS:
5150, 5608, 5808, 8700, 8739, 8763

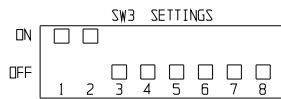

RS-232 SPECIFICATION

BAUD = 1200
PARITY = N
BITS = 8
STOP BITS = 2

REMOTE CONTACTS/ANALOG OUTPUT	
PIN# 1	Analog Output +
PIN# 2	Analog Output -
PIN# 3	Not Connected
PIN# 4	Not Connected
PIN# 5	Normally Closed
PIN# 6	Common
PIN# 7	Normally Open

CONTACT RATING: 1A @ 30V
CONTACTS IN ALARM STATE

RS-232 PORT	
PIN# 2	TXD
PIN# 3	RXD
PIN# 5	GND

SW1 Settings for Analog Output

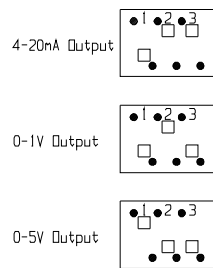

SW2 Settings for Communication Output

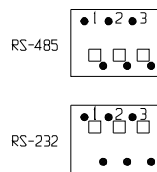

1. Lid switch shown in open position.
2. Battery switch shown in the OFF position.
3. Circuit breaker switch shown in OFF position.
4. Options and accessories shown in dashed lines.

REV	REV NO.	DATE	BY	CAQ	APPD	DESCRIPTION OF REVISION
1	FR-2386	08-29-12	AJC	SAG	CCS	REVISED OPERATING RANGE FROM 103-127V
0	FR-2202	05/03/11	SRS	SAG	DRP	RELEASED FOR PRODUCTION / RELEASE 6

Electrical Schematic
Model:
3 cu ft 120V
ULT Chest Freezer



THIS DOCUMENT CONTAINS PROPRIETARY INFORMATION AND SUCH INFORMATION IS NOT TO BE DISCLOSED TO OTHERS FOR ANY PURPOSE NOR USED FOR MANUFACTURING PURPOSES WITHOUT WRITTEN PERMISSION FROM THERMO FISHER SCIENTIFIC



BOX 649, MARIETTA, OHIO 45750

MODEL/PART NAME: 5600 SERIES, 120V, ULT FREEZERS			
DNG TITLE: UNIT SCHEMATIC			
DWN: HCE	CAD: KDG	APPD: LDN	DATE: 10-10-10 SCALE: NONE
MATERIAL:			
PAINT COLOR:			
TOLERANCE UNLESS OTHERWISE SPECIFIED	DRAWING NUMBER	SIZE	
ANGLES: DECIMAL: .XX±	8700-70-1	D	
ANGLES: DECIMAL: .XXX±			

8700-70-1-D REV. 1
Page 3 of 3

Section 10
Electrical Schematics

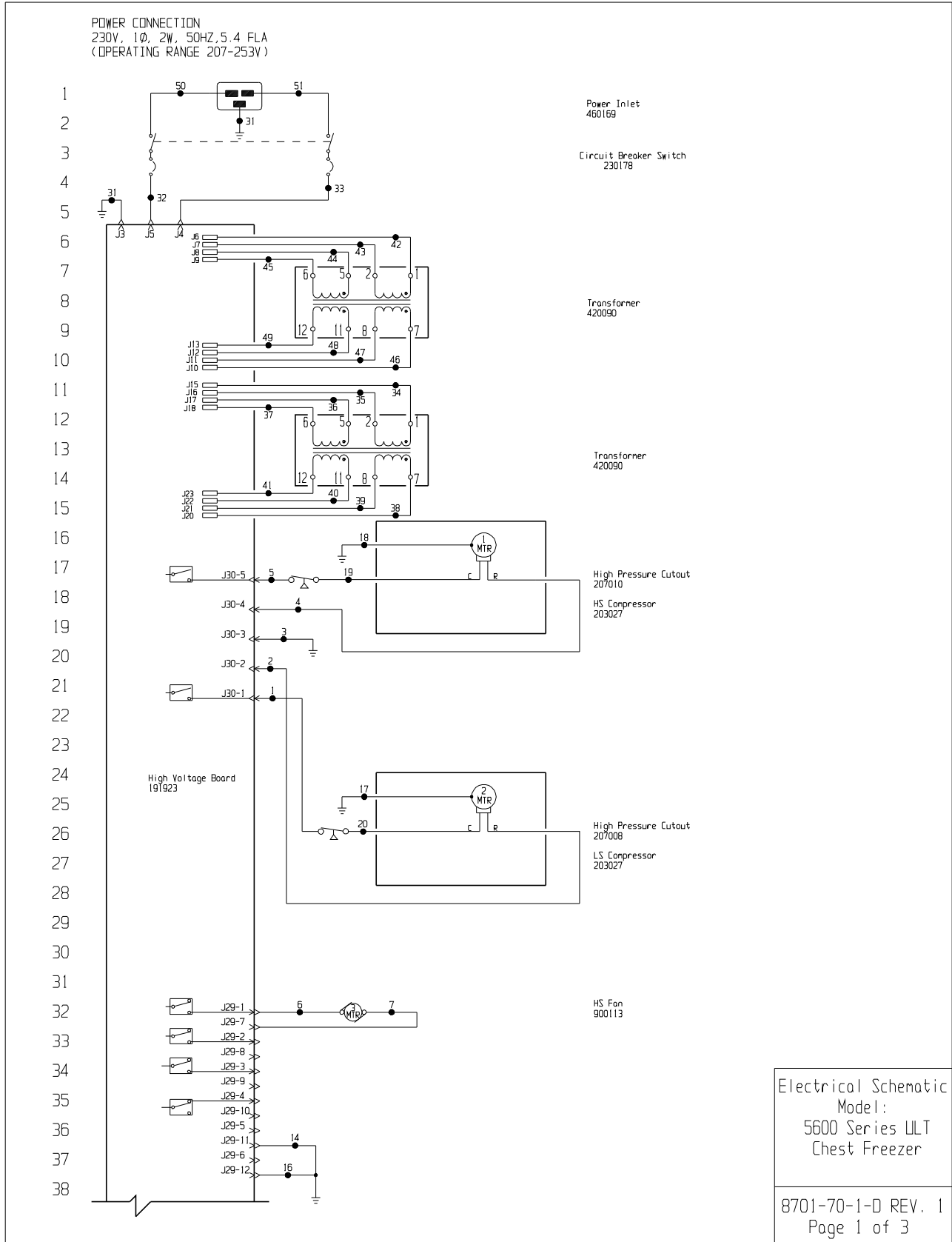

Section 10
Electrical Schematics

WIRE #	COLOR	GAUGE	WIRE #	COLOR	GAUGE	
77			25	WHT	18	
78	1	BLK	14			
	2	RED	14			
79	3	GRN/YEL	14			
	4	RED	14			
80	5	BLK	14			
	6	BLK	18			
81	7	BLK	18			
	8		31	GRN/YEL	14	
82	9		32	BLK	14	
	10		33	BLU	14	
83	11		34	BLK	14	
	12		35	BLU	14	
84	13		36	BLK	14	
	14	GRN/YEL	18	37	BLU	14
	15		38	BLK	14	
85	16	GRN/YEL	18	39	BLU	14
	17	GRN/YEL	14	40	BLK	14
86	18	GRN/YEL	14	41	BLU	14
	19	BLK	14	42	BLK	14
87	20	BLK	14	43	BLU	14
	21	BLK	18	44	BLK	14
88	22	RED	18	45	BLU	14
	23	BLK	18	46	BLK	14
89	24	RED	18	47	BLU	14
			48	BLK	14	
90			49	BLU	14	
			50	BLK	14	
91			51	BLU	14	

3 CU. FT. CHEST MODELS:
5151, 5809, 8701, 8740, 8764

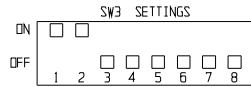

REMOTE CONTACTS/ANALOG OUTPUT	
PIN# 1	Analog Output +
PIN# 2	Analog Output -
PIN# 3	Not Connected
PIN# 4	Not Connected
PIN# 5	Normally Closed
PIN# 6	Common
PIN# 7	Normally Open

CONTACT RATING: 1A @ 30V
CONTACTS IN ALARM STATE

RS-232 SPECIFICATION

BAUD = 1200
PARITY = N
BITS = 8
STOP BITS = 2

RS-232 PORT	
PIN# 2	TXD
PIN# 3	RXD
PIN# 5	GND

SW1 Settings for Analog Output

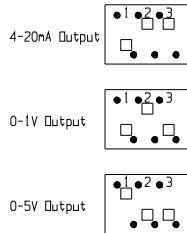

SW2 Settings for Communication Output

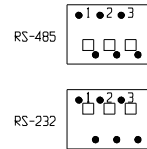

- Lid switch shown in open position.
- Battery switch shown in the OFF position.
- Circuit breaker switch shown in OFF position.
- Options and accessories shown in dashed lines.



THIS DOCUMENT CONTAINS PROPRIETARY INFORMATION AND SUCH INFORMATION IS NOT TO BE DISCLOSED TO OTHERS FOR ANY PURPOSE NOR USED FOR MANUFACTURING PURPOSES WITHOUT WRITTEN PERMISSION FROM THERMO FISHER SCIENTIFIC



BOX 649, MARIETTA, OHIO 45750

REV	ECN NO.	DATE	BY	APPD	DESCRIPTION OF REVISION	
1	FR-2386	08-29-12	AJC	KDG	CCS	REVISED OPERATING RANGE FROM 207-250V
0	FR-2202	05/19/11	SRS	SAG	DRP	RELEASED FOR PRODUCTION / RELEASE G

MODEL/PART NAME: 5600 SERIES, 230V, ULT FREEZERS

DWG TITLE: UNIT SCHEMATIC

DWN: SAG CAD: SAG APPD: LON DATE: 05/19/11 SCALE: NONE

MATERIAL:

PAINT COLOR:

TOLERANCE UNLESS OTHERWISE SPECIFIED DRAWING NUMBER SIZE

ANGLES: DECIMAL: .XX± XXX± 8701-70-1 D

Electrical Schematic
Model:
5600 Series ULT
Chest Freezer

8701-70-1-D REV. 1
Page 3 of 3

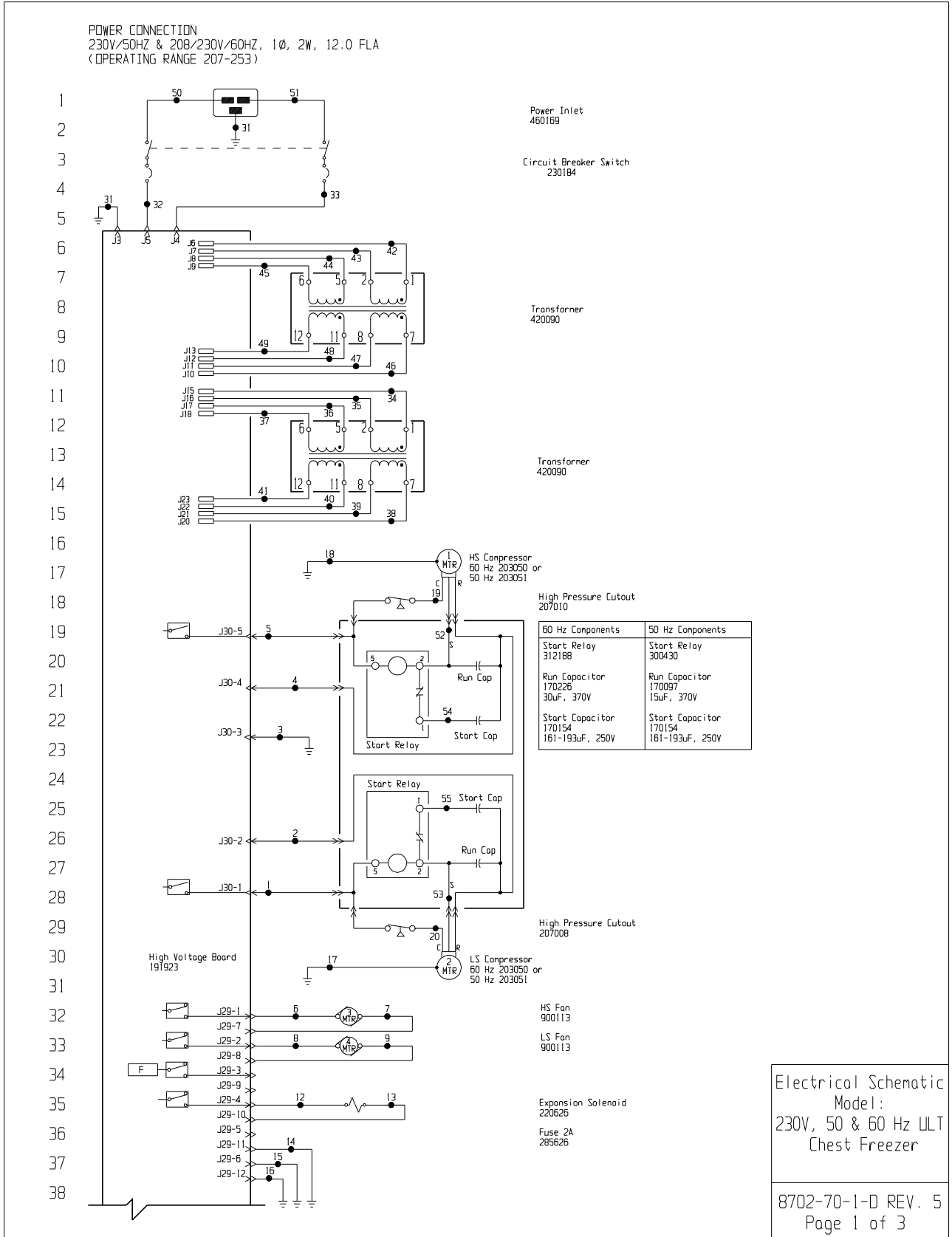

Section 10
Electrical Schematics

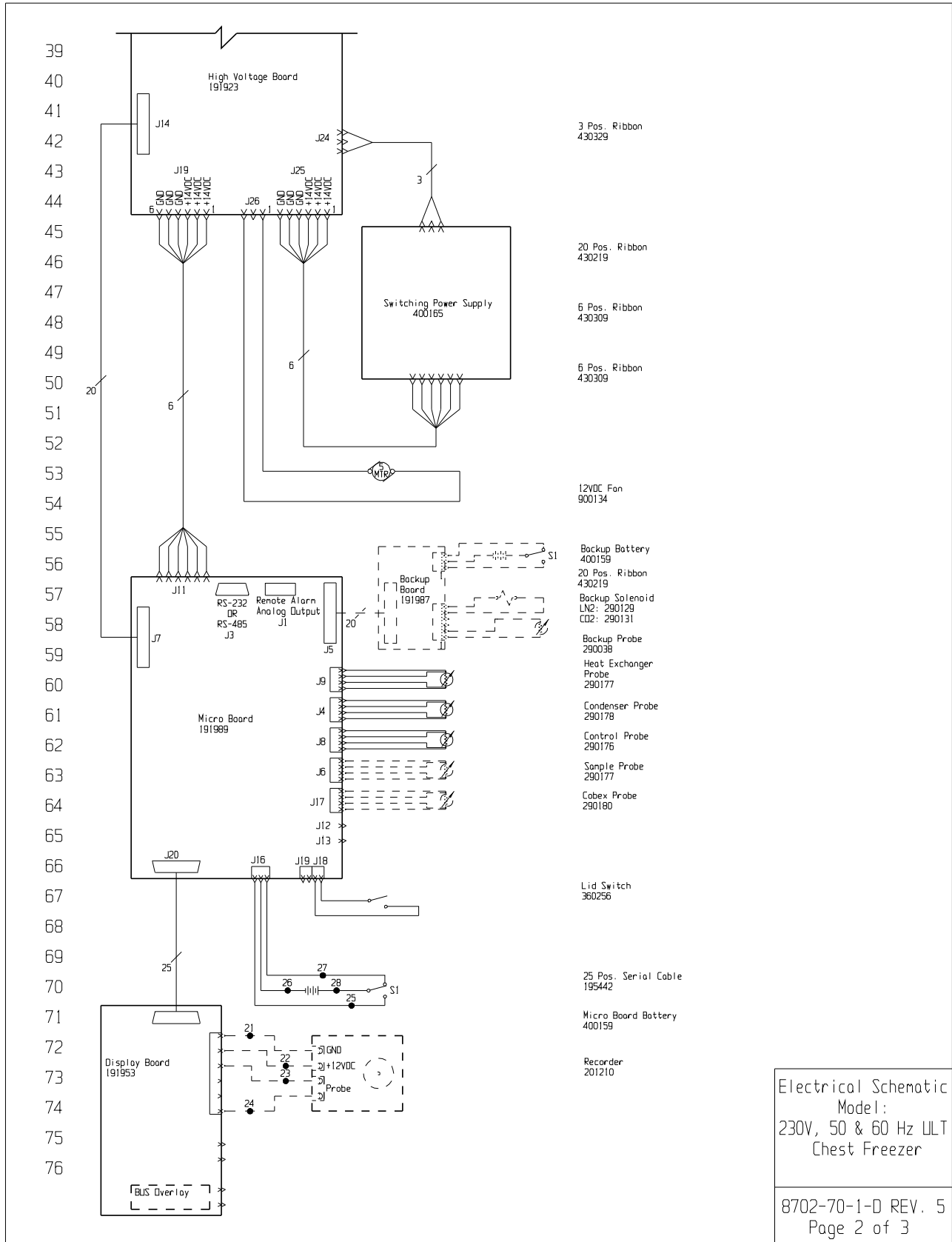

WIRE #	COLOR	GAUGE	WIRE #	COLOR	GAUGE
77	1	14	29	-	-
	2	14	30	-	-
78	3	14	31	GRN/YEL	14
	4	14	32	BLK	14
	5	14	33	BLU	14
79	6	18	34	BLK	14
	7	18	35	BLU	14
80	8	18	36	BLK	14
	9	18	37	BLU	14
81	10	18	38	BLK	14
	11	18	39	BLU	14
82	12	18	40	BLK	14
	13	18	41	BLU	14
83	14	18	42	BLK	14
	15	18	43	BLU	14
84	16	18	44	BLK	14
	17	14	45	BLU	14
85	18	14	46	BLK	14
	19	14	47	BLU	14
86	20	14	48	BLK	14
	21	18	49	BLU	14
87	22	18	50	BLK	14
	23	18	51	BLU	14
88	24	18	52	YEL/WHT	14
	25	18	53	YEL	14
89	26	18	54	BLU/WHT	14
	27	18	55	BLU	14
90	28	18			

CHEST MODELS:
12.7 CU.FT. - 5152, 5158, 5612, 5613, 5812, 5813, 8702, 8703, 8742, 8743, 8765, 8767
17 CU.FT. - 5155, 5159, 5819, 5822, 8706, 8707, 8746, 8747, 8770, 8771
20 CU.FT. - 5156, 5160, 5620, 5623, 5820, 5823, 8708, 8709, 8749, 8750, 8772, 8773

RS-232 SPECIFICATION

BAUD = 1200
PARITY = N
BITS = 8
STOP BITS = 2

RS-232 PORT	
PIN# 2	TXD
PIN# 3	RXD
PIN# 5	GND

REMOTE CONTACTS/ANALOG OUTPUT	
PIN# 1	Analog Output +
PIN# 2	Analog Output -
PIN# 3	Not Connected
PIN# 4	Not Connected
PIN# 5	Normally Closed
PIN# 6	Common
PIN# 7	Normally Open

CONTACT RATING: 1A @ 30V
CONTACTS IN ALARM STATE

SW1 Settings for Analog Output

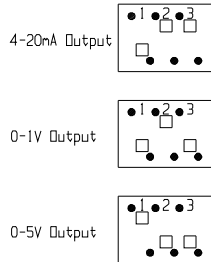

SW2 Settings for Communication Output

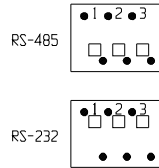

SW3 SETTINGS



1. Schematic represents chest models.
2. Door switches shown in open position.
3. Battery switch shown in the OFF position.
4. Circuit breaker switch shown in OFF position.
5. Options and accessories shown in dashed lines.

5	FR-2805	06-19-15	SUN	SAG	CCS	312180 WAS 300420
4	FR-2753	12-17-14	MW	KDG	DRP	ADDED MODELS 5613 & 5623
3	FR-2366	08-29-12	AJC	SAG	DRP	REVISED OPERATING RANGE FROM 208-240V
2	FR-2366	07-27-12	NAM	KDG	DRP	ENG. 300421 RELAY TO 300420, 300420 TO 300430
1	FR-2267	08/17/11	JWE	SAG	DRP	COMPRESSOR CHANGE / RELEASE 7
0	FR-2202	05/04/11	SPS	SAG	DLP	RELEASED FOR PRODUCTION / RELEASE 6
REV	ECN NO.	DATE	BY	CAD	APPD	DESCRIPTION OF REVISION

Electrical Schematic
Model:
230V, 50 & 60 Hz ULT
Chest Freezer

THIS DOCUMENT CONTAINS PROPRIETARY INFORMATION AND SUCH INFORMATION IS NOT TO BE DISCLOSED TO OTHERS FOR ANY PURPOSE NOR USED FOR MANUFACTURING PURPOSES WITHOUT WRITTEN PERMISSION FROM THERMO FISHER SCIENTIFIC

MODEL/PART NAME: ULT -BCC CHEST FREEZERS, 230V, 50 & 60Hz					
DWG TITLE: UNIT SCHEMATIC					
OWN:	SAG	CAD:	SAG	APPD:	
DATE:	05/04/11	SCALE:	NINE		



ThermoFisher
SCIENTIFIC
BOX 649, MARIETTA, OHIO 45750

PAINT COLOR:		DRAWING NUMBER		SIZE
TOLERANCE UNLESS OTHERWISE SPECIFIED	XXX±	8702-70-1		D
ANGLES:	DECIMAL: .XXX±			

8702-70-1-D REV. 5
Page 3 of 3

Section 10
Electrical Schematics

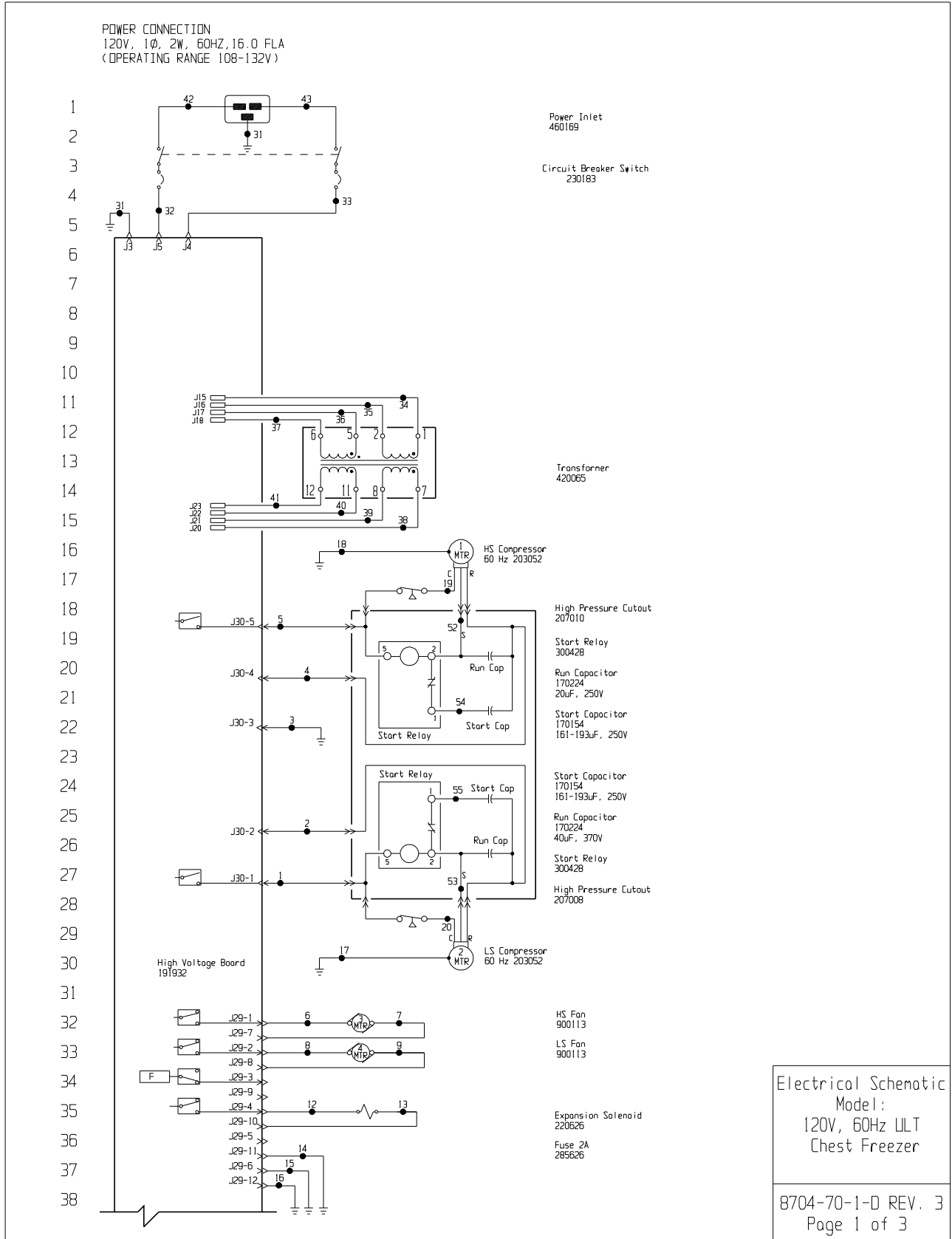

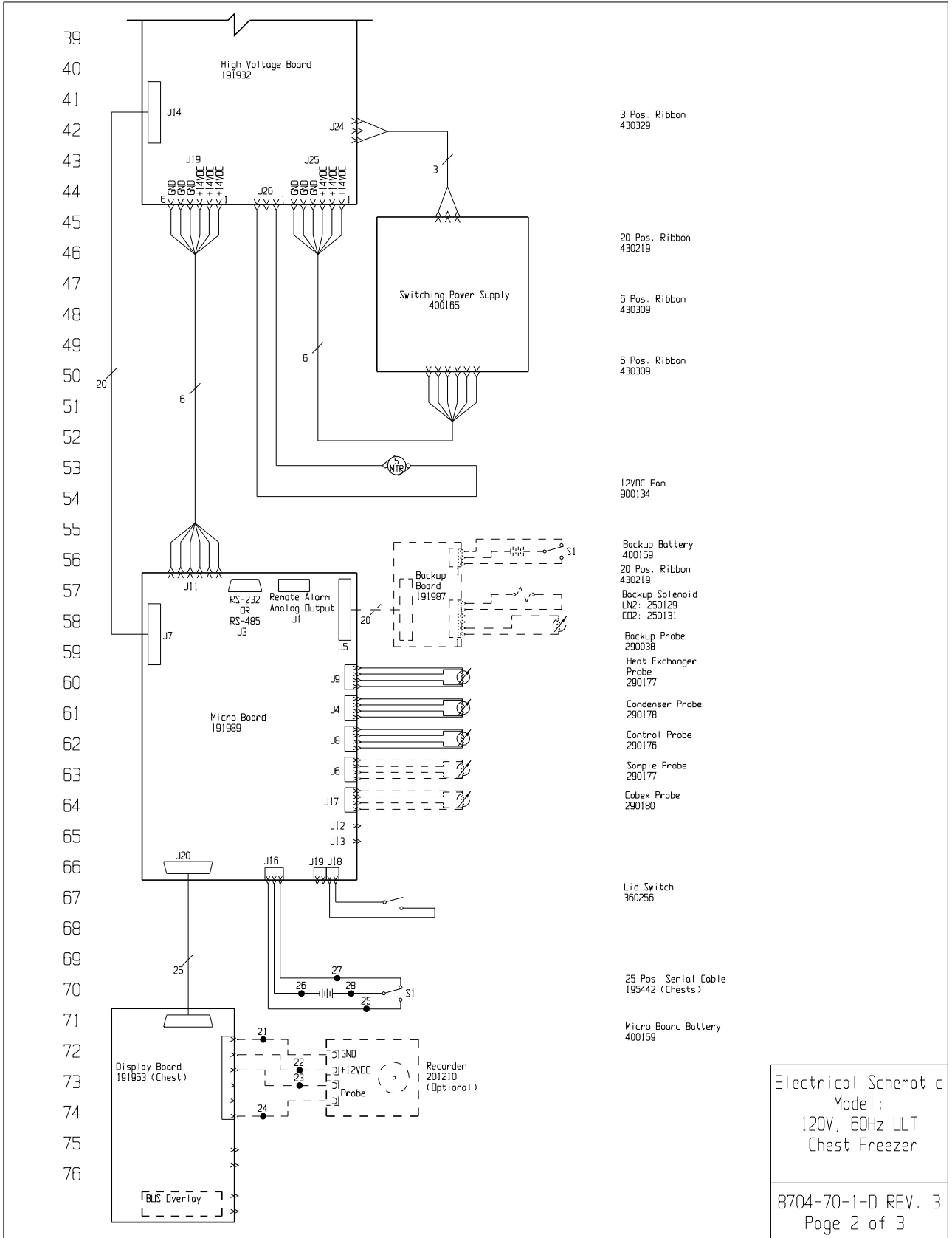

Section 10
Electrical Schematics

WIRE #	WIRE #	COLOR	GAUGE	WIRE #	COLOR	GAUGE
77	1	BLK	14	29	-	-
	2	RED	14	30	-	-
78	3	GRN/YEL	14	31	GRN/YEL	14
	4	RED/WHT	14	32	BLK	14
79	5	BLK/WHT	14	33	BLU	14
	6	BLK	18	34	BLK	14
80	7	BLK	18	35	BLU	14
	8	BLK	18	36	BLK	14
81	9	BLK	18	37	BLU	14
	10	BLK	18	38	BLK	14
82	11	BLK	18	39	BLU	14
	12	BLK	18	40	BLK	14
83	13	BLK	18	41	BLU	14
	14	GRN/YEL	18	42	BLK	14
84	15	GRN/YEL	18	43	BLU	14
	16	GRN/YEL	18	44	-	-
85	17	GRN/YEL	14	45	-	-
	18	GRN/YEL	14	46	-	-
86	19	BLK/WHT	14	47	-	-
	20	BLK	14	48	-	-
87	21	BLK	18	49	-	-
	22	RED	18	50	-	-
88	23	BLK	18	51	-	-
	24	RED	18	52	YEL/WHT	14
89	25	WHT	18	53	YEL	14
	26	BLK	18	54	BLU/WHT	14
90	27	BLK	18	55	BLU	14
91	28	RED	18			

CHEST MODELS:
12.7 CU.FT. - 5153, 5615, 5815, 8704, 8744, 8768
17 CU.FT. - 5154, 5818, 8705, 8745, 8769
20 CU.FT. - 5157, 5621, 5821, 8710, 8751, 8774

RS-232 SPECIFICATION

BAUD = 1200
PARITY = N
BITS = 8
STOP BITS = 2

RS-232 PORT	
PIN# 2	TXD
PIN# 3	RXD
PIN# 5	GND

REMOTE CONTACTS/ANALOG OUTPUT	
PIN# 1	Analog Output +
PIN# 2	Analog Output -
PIN# 3	Not Connected
PIN# 4	Not Connected
PIN# 5	Normally Closed
PIN# 6	Common
PIN# 7	Normally Open

CONTACT RATING: 1A @ 30V
CONTACTS IN ALARM STATE

SW1 Settings for Analog Output

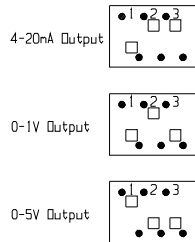

SW2 Settings for Communication Output

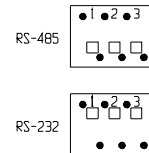

SW3 SETTINGS

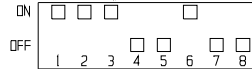

1. Schematic represents chest models.
2. Door switches shown in open position.
3. Battery switch shown in the OFF position.
4. Circuit breaker switch shown in OFF position.
5. Options and accessories shown in dashed lines.

REV	ECN NO	DATE	BY	CAD	APPD	DESCRIPTION OF REVISION
3	FR-2386	08-29-12	AJC	SAG	CCS	REVISED OPERATING RANGE FROM 108-130V
2	FR-2386	07-27-12	MAN	KDG	DRP	CHG. 300421 START RELAY TO 300428
1	FR-2267	08/17/11	SAG	SAG	DRP	COMPRESSOR CHANGE / RELEASE 7
0	FR-2202	05/04/11	SRS	SAG	DRP	RELEASED FOR PRODUCTION / RELEASE 6

Electrical Schematic
Model:
120V, 60Hz ULT
Chest Freezer

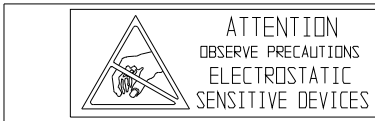

THIS DOCUMENT CONTAINS PROPRIETARY INFORMATION AND SUCH INFORMATION IS NOT TO BE DISCLOSED TO OTHERS FOR ANY PURPOSE NOR USED FOR MANUFACTURING PURPOSES WITHOUT WRITTEN PERMISSION FROM THERMO FISHER SCIENTIFIC

ThermoFisher
SCIENTIFIC
BOX 649, MARIETTA, OHIO 45750

MODEL/PART NAME: ULT -BCC CHEST FREEZERS, 120V, 60Hz			
DWG TITLE: UNIT SCHEMATIC			
DWN: SAG	CAD: SAG	APPD: DRP	DATE: 05-04-11 SCALE: NONE
MATERIAL:			
PAINT COLOR:			
TOLERANCE UNLESS OTHERWISE SPECIFIED	XX±	DRAWING NUMBER	SIZE
ANGLES: DECIMAL: XXX±		8704-70-1	D

8704-70-1-D REV. 3
Page 3 of 3

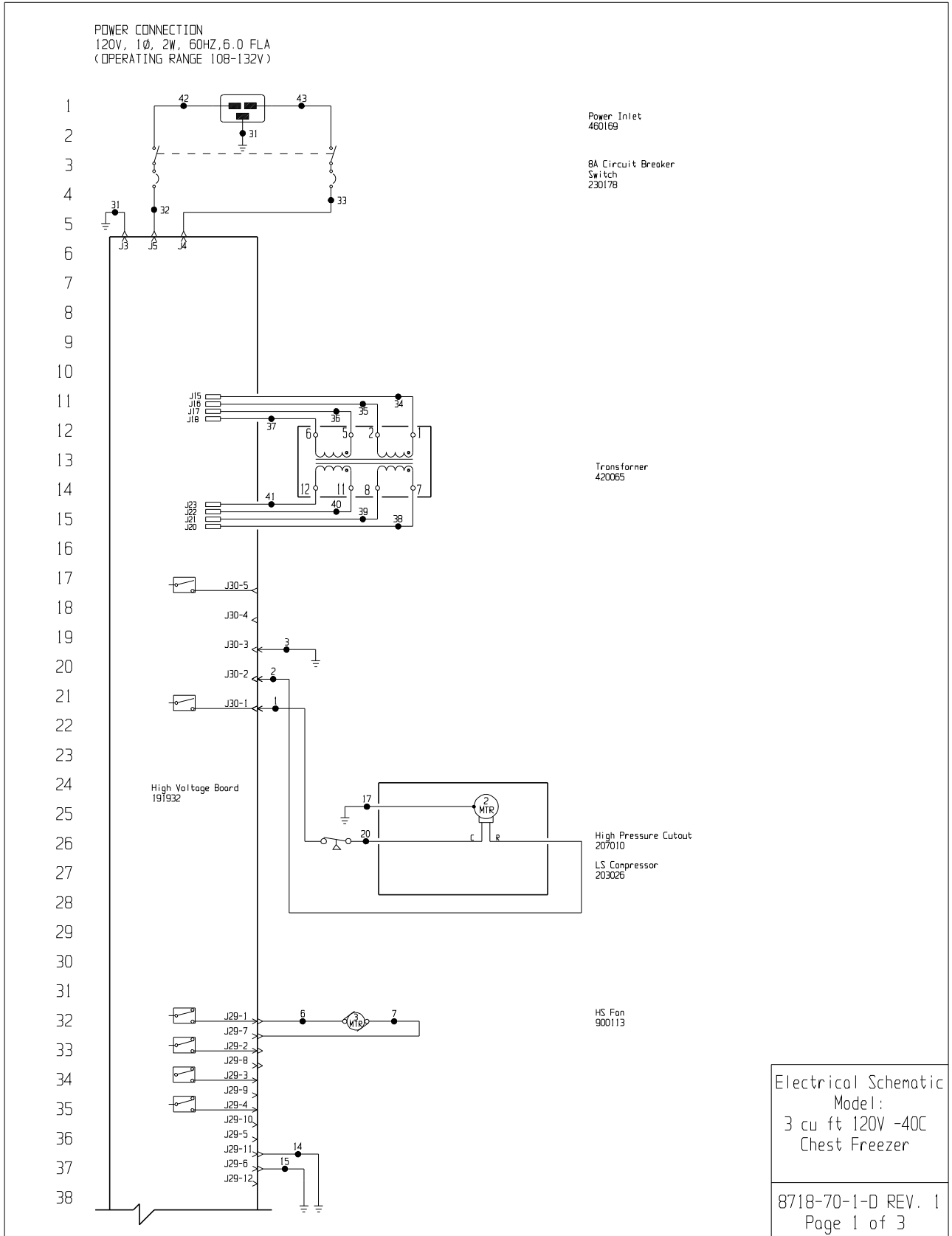

Section 10
Electrical Schematics

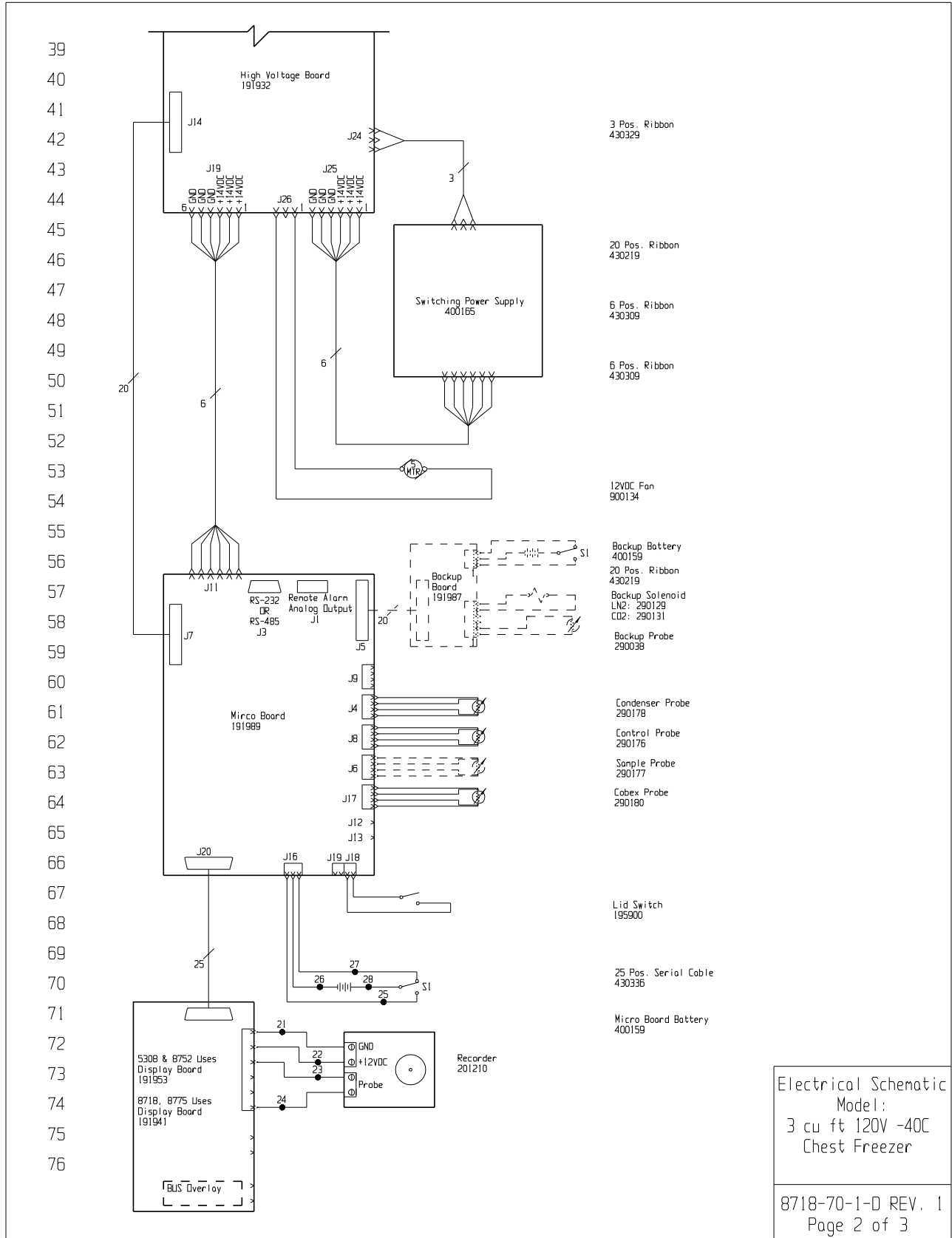

WIRE #	WIRE #	COLOR	GAUGE	WIRE #	COLOR	GAUGE
77	1	BLK	14	25	WHT	18
78	2	RED	14	26	BLK	18
	3	GRN/YEL	14	27	BLK	18
79	4			28	RED	18
	5			29		
80	6	BLK	18	30		
	7	BLK	18	31	GRN/YEL	14
	8	BLK	18	32	BLK	14
81	9	BLK	18	33	BLU	14
	10			34	BLK	14
82	11			35	BLU	14
	12			36	BLK	14
83	13			37	BLU	14
	14	GRN/YEL	18	38	BLK	14
84	15	GRN/YEL	18	39	BLU	14
	16			40	BLK	14
85	17	GRN/YEL	14	41	BLU	14
	18			42	BLK	14
86	19			43	BLU	14
	20	BLK	14			
87	21	BLK	18			
	22	RED	18			
88	23	BLK	18			
	24	RED	18			

3 CU. FT. CHEST MODELS:
5308, 8718, 8752, 8775

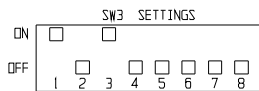

RS-232 SPECIFICATION

BAUD = 1200
PARITY = N
BITS = 8
STOP BITS = 2

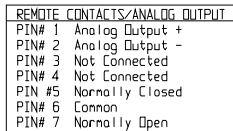
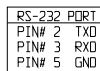

CONTACT RATING: 1A @ 30V
CAONACTS IN ALARM STATE

SW1 Settings for Analog Output

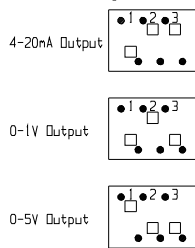

SW2 Settings for Communication Output

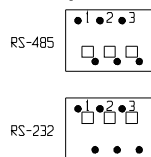

1. Door switch shown in open position.
2. Battery switch shown in the OFF position.
3. Circuit breaker switch shown in OFF position.
4. Options and accessories shown in dashed lines.

REV	ECN NO.	DATE	BY	CAO	APPD	DESCRIPTION OF REVISION
1	FR-2386	08-29-12	AJC	SAG	CCS	REVISED OPERATING RANGE FROM 108-130V
0	FR-2202	05/03/11	SRS	SAG	DRP	RELEASED FOR PRODUCTION / RELEASE 6

THIS DOCUMENT CONTAINS PROPRIETARY INFORMATION AND SUCH INFORMATION IS NOT TO BE DISCLOSED TO OTHERS FOR ANY PURPOSE NOR USED FOR MANUFACTURING PURPOSES WITHOUT WRITTEN PERMISSION FROM THERMO FISHER SCIENTIFIC

MODEL/PART NAME: 3CF -40" CHEST FREEZER, 120V
DWG TITLE: ELECTRICAL SCHEMATIC
DWN: SAG CAD: SAG APPD: DRP DATE: 05/11/11 SCALE: NONE



ThermoFisher
SCIENTIFIC
BOX 649, MARIETTA, OHIO 45750

MATERIAL:
PAINT COLOR:
TOLERANCE UNLESS OTHERWISE SPECIFIED
DRAWING NUMBER: 8718-70-1
SIZE: D
ANGLES: DECIMAL: .XX+/- .XXX-1

Electrical Schematic
Model:
3 cu ft 120V -40C
Chest Freezer

8718-70-1-D REV. 1
Page 3 of 3

Section 10
Electrical Schematics

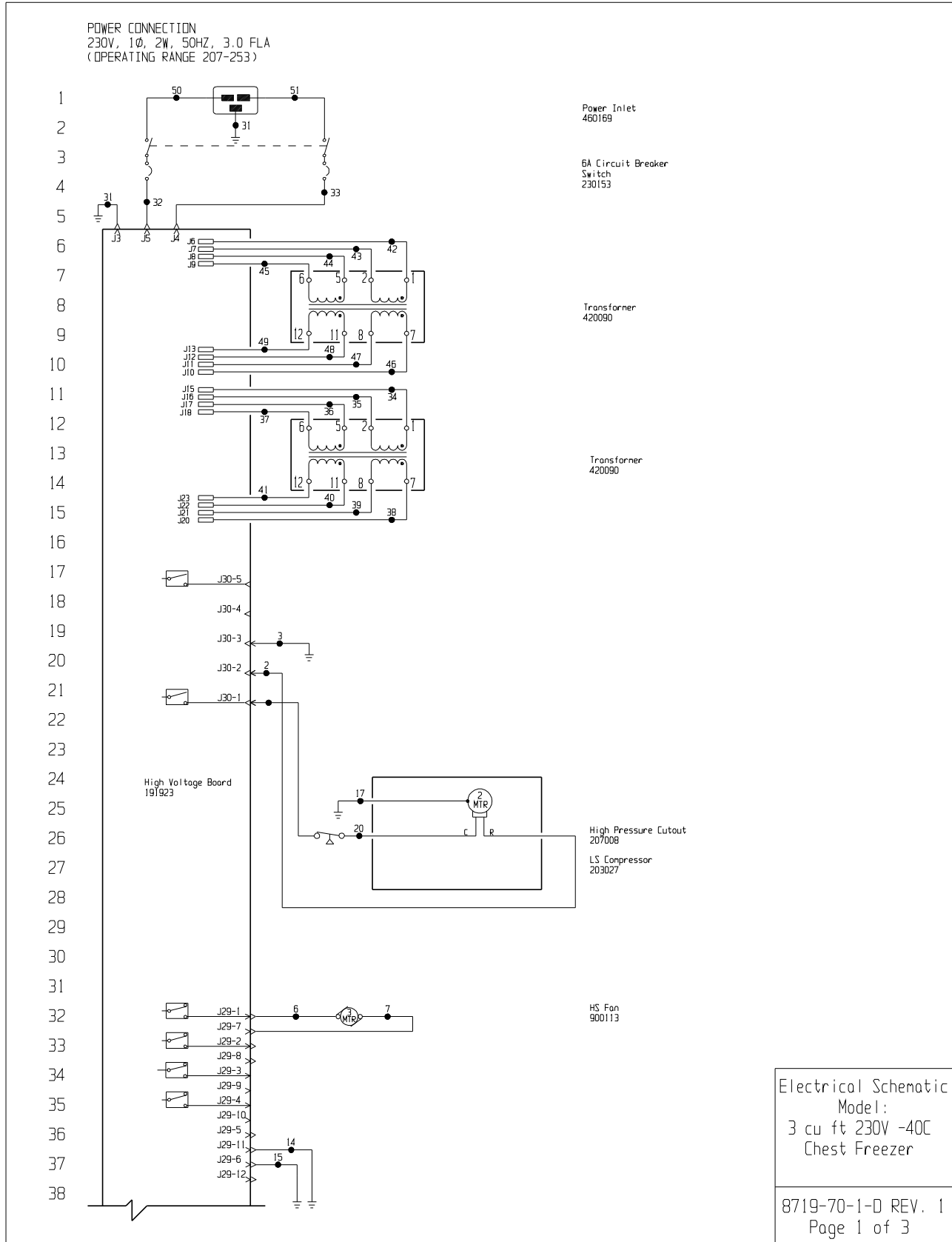

Section 10
Electrical Schematics

77	WIRE #	COLOR	GAUGE	WIRE #	COLOR	GAUGE
	1	BLK	14	25	WHT	18
78	2	RED	14	26	BLK	18
	3	GRN/YEL	14	27	BLK	18
79	4			28	RED	18
	5			29		
80	6	BLK	18	30	RED	18
	7	BLK	18	31	GRN/YEL	14
81	8	BLK	18	32	BLK	14
	9	BLK	18	33	BLU	14
82	10			34	BLK	14
	11			35	BLU	14
83	12			36	BLK	14
	13			37	BLU	14
84	14	GRN/YEL	18	38	BLK	14
	15	GRN/YEL	18	39	BLU	14
85	16			40	BLK	14
	17	GRN/YEL	14	41	BLU	14
86	18			42	BLK	14
	19			43	BLU	14
87	20	BLK	14	44	BLK	14
	21	BLK	18	45	BLU	14
88	22	RED	18	46	BLK	14
	23	BLK	18	47	BLU	14
89	24			48	BLK	14
				49	BLU	14
90				50	BLK	14
				51	BLU	14

3 CU. FT. CHEST MODELS
5309, 8719, 8753, 8776

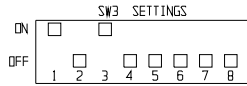

REMOTE CONTACTS/ANALOG OUTPUT
 PIN# 1 Analog Output +
 PIN# 2 Analog Output -
 PIN# 3 Shield
 PIN# 4 Shield
 PIN# 5 Normally Closed
 PIN# 6 Common
 PIN# 7 Normally Open
 CONTACT RATING: 1A @ 30V
 CONTACTS IN ALARM STATE

RS-232 SPECIFICATION

BAUD = 1200
 PARITY = N
 BITS = 8
 STOP BITS = 2

RS-232 PORT
 PIN# 2 TXD
 PIN# 3 RXD
 PIN# 5 GND

SW1 Settings for Analog Output

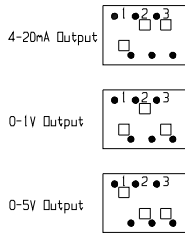

SW2 Settings for Communication Output

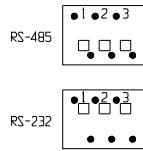

1. Door switch shown in open position.
2. Battery switch shown in the OFF position.
3. Circuit breaker switch shown in OFF position.
4. Options and accessories shown in dashed lines.

REV	ECN NO.	DATE	BY	CAD	APPD	DESCRIPTION OF REVISION
1	FR-2386	08-29-12	AJC	SAG	CCS	REVISED OPERATING RANGE FROM 208-240V
0	FR-2202	05/03/11	SRS	SAG	DRP	RELEASED FOR PRODUCTION / RELEASE 6

Electrical Schematic
 Model:
 3 cu ft 230V -40C
 Chest Freezer



THIS DOCUMENT CONTAINS PROPRIETARY INFORMATION AND SUCH INFORMATION IS NOT TO BE DISCLOSED TO OTHERS FOR ANY PURPOSE NOR USED FOR MANUFACTURING PURPOSES WITHOUT WRITTEN PERMISSION FROM THERMO FISHER SCIENTIFIC

ThermoFisher
SCIENTIFIC
 BOX 649, MARIETTA, OHIO 45750

MODEL/PART NAME: 3CF -40° CHEST FREEZER, 230V						
DWG TITLE: ELECTRICAL SCHEMATIC						
OWN: HCE	CAD: KDG	APPD: LON	DATE: 10-10-10	SCALE: NONE		
MATERIAL:						
PAINT COLOR:						
TOLERANCE UNLESS OTHERWISE SPECIFIED			DRAWING NUMBER	SIZE		
ANGLES: .XX±	DECIMAL: .XXX±		8719-70-1	D		

8719-70-1-D REV. 1
 Page 3 of 3

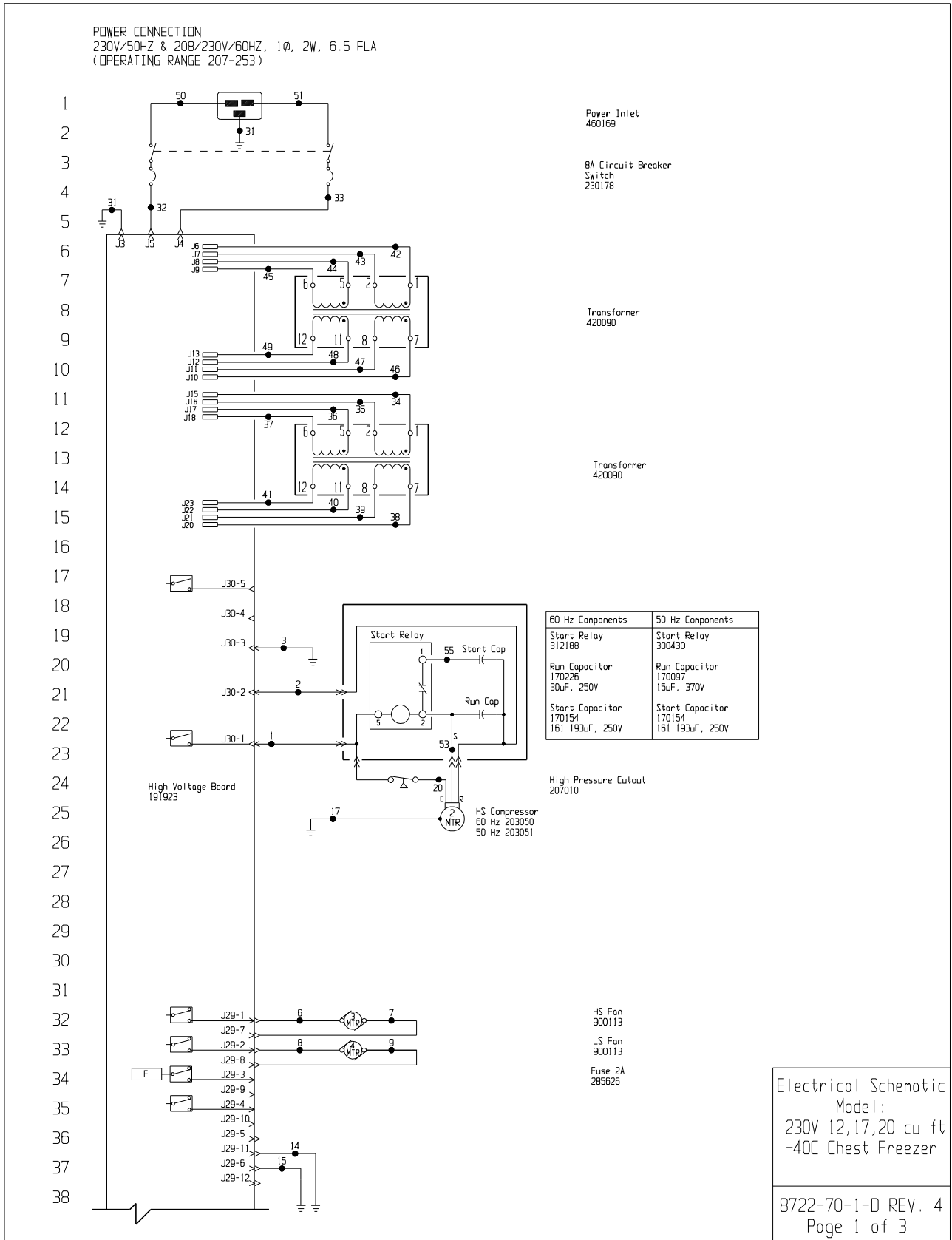

Section 10
Electrical Schematics

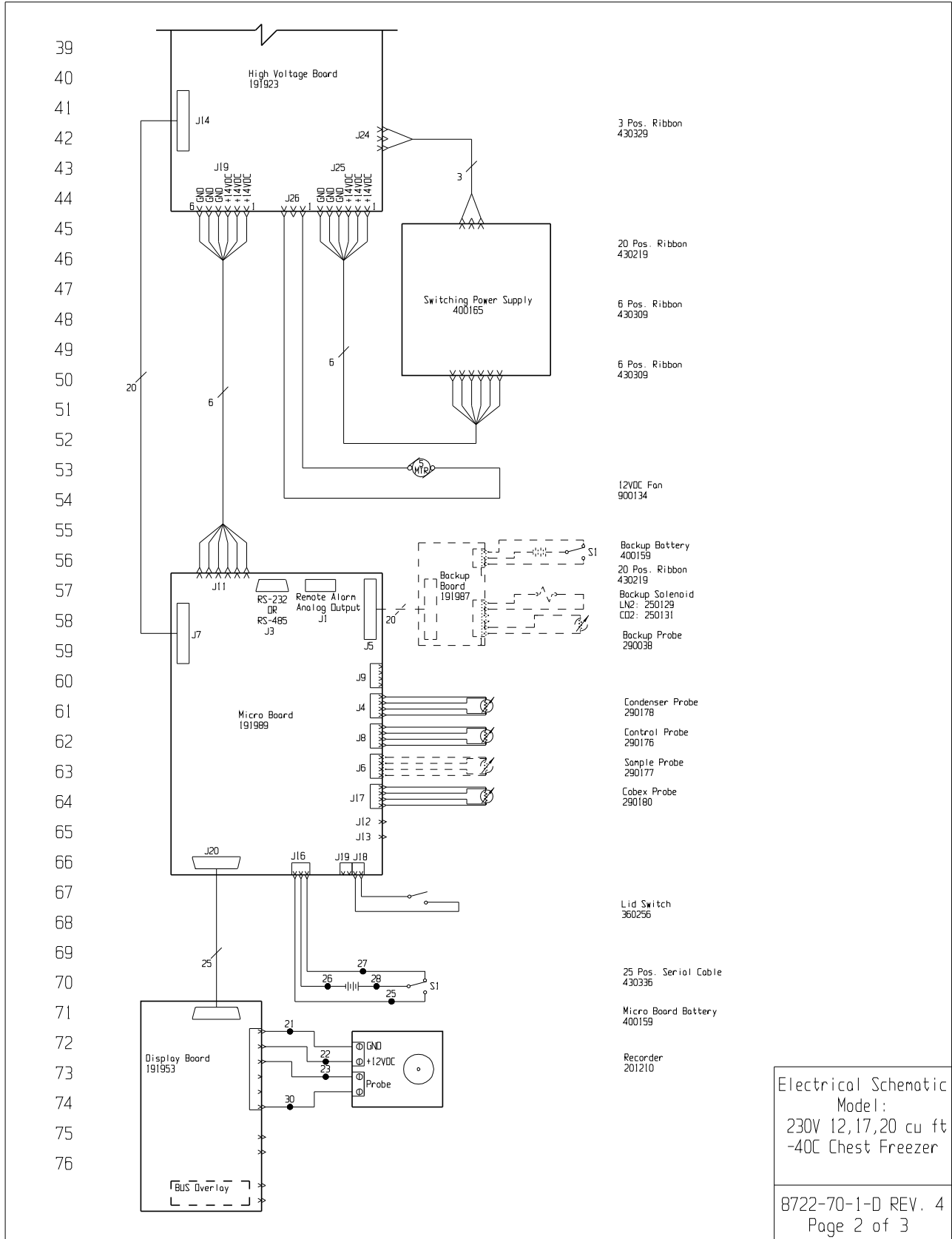

WIRE #	COLOR	GAUGE	WIRE #	COLOR	GAUGE
77	1	BLK	14	29	
	2	RED	14	30	RED
	3	GRN/YEL	14	31	GRN/YEL
78	4		32	BLK	14
	5		33	BLU	14
79	6	BLK	34	BLK	14
	7	BLK	35	BLU	14
80	8	BLK	36	BLK	14
	9	BLK	37	BLU	14
81	10		38	BLK	14
	11		39	BLU	14
82	12		40	BLK	14
	13		41	BLU	14
83	14	GRN/YEL	42	BLK	14
	15	GRN/YEL	43	BLU	14
84	16		44	BLK	14
	17	GRN/YEL	45	BLU	14
85	18		46	BLK	14
	19		47	BLU	14
86	20	BLK	48	BLK	14
	21	BLK	49	BLU	14
87	22	RED	50	BLK	14
	23	BLK	51	BLU	14
88	24		52	-	-
	25	WHT	53	YEL	14
	26	BLK	54	-	-
89	27	BLK	55	BLU	14
	28	RED			

CHEST MODELS:
12.7 CU.FT. - 5312, 5313, 8722, 8727, 8754, 8755, 8777, 8778
17 CU.FT. - 5319, 5322, 8731, 8733, 8758, 8759, 8781, 8782
20 CU.FT. - 5320, 5323, 8734, 8736, 8760, 8761, 8783, 8784

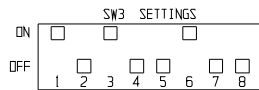

RS-232 SPECIFICATION

BAUD = 1200
PARITY = N
BITS = 8
STOP BITS = 2

RS-232 PORT	
PIN# 2	TXD
PIN# 3	RXD
PIN# 5	GND

REMOTE CONTACTS/ANALOG OUTPUT	
PIN# 1	Analog Output +
PIN# 2	Analog Output -
PIN# 3	Shield
PIN# 4	Shield
PIN# 5	Normally Closed
PIN# 6	Common
PIN# 7	Normally Open

CONTACT RATING: 1A @ 30V
CONTACTS IN ALARM STATE

SW1 Settings for Analog Output

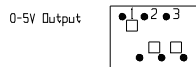
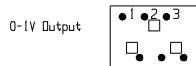
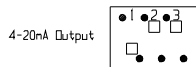

SW2 Settings for Communication Output

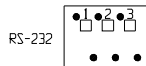
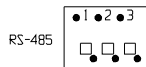

1. Door switch shown in open position.
2. Battery switch shown in the OFF position.
3. Circuit breaker switch shown in OFF position.
4. Options and accessories shown in dashed lines.

REV	ECN NO.	DATE	BY	CAD	APPD	DESCRIPTION OF REVISION
4	FR-2805	06-19-15	S.JN	SAG	CCS	312188 WAS 300429
3	FR-2386	08-29-12	AJC	SAG	MSB	REVISED OPERATING RANGE FROM 208-240V
2	FR-2386	07-27-12	NAM	KDG	MSB	CHG. 300421 RELAY TO 300429, 300420 TO 300430
1	FR-2267	10/26/11	JNE	SAG	DRP	COMPRESSOR CHANGE / RELEASE 7
0	FR-2202	05/03/11	SRS	SAG	LON	RELEASED FOR PRODUCTION / RELEASE 6

Electrical Schematic
Model:
230V 12,17,20 cu ft
-40C Chest Freezer

THIS DOCUMENT CONTAINS PROPRIETARY INFORMATION AND SUCH INFORMATION IS NOT TO BE DISCLOSED TO OTHERS FOR ANY PURPOSE NOR USED FOR MANUFACTURING PURPOSES WITHOUT WRITTEN PERMISSION FROM THERMO FISHER SCIENTIFIC

MODEL/PART NAME: 12,17,20CF -40° CHEST FREEZERS, 230V	
DWG TITLE: UNIT SCHEMATIC	
DWN: HCE	CAD: KDG
APPD: LON	DATE: 10-10-10
SCALE: NONE	



ThermoFisher
SCIENTIFIC
BOX 649, MARLETTA, OHIO 45750

MATERIAL:	
PAINT COLOR:	
TOLERANCE UNLESS OTHERWISE SPECIFIED	DRAWING NUMBER
ANGLES: DECIMAL: .XX±	8722-70-1
XXX±	SIZE
	D

8722-70-1-D REV. 4
Page 3 of 3

Section 10
Electrical Schematics

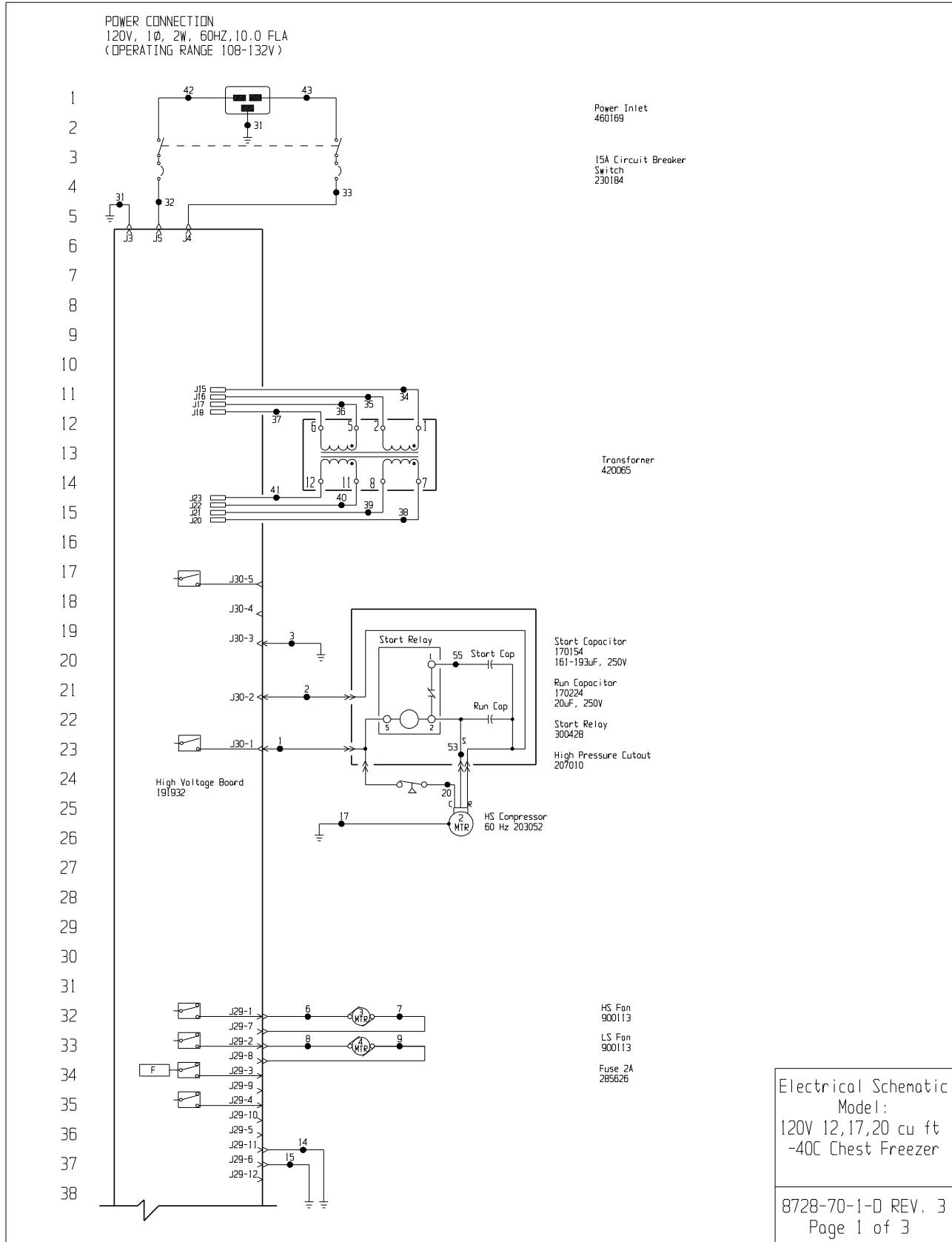

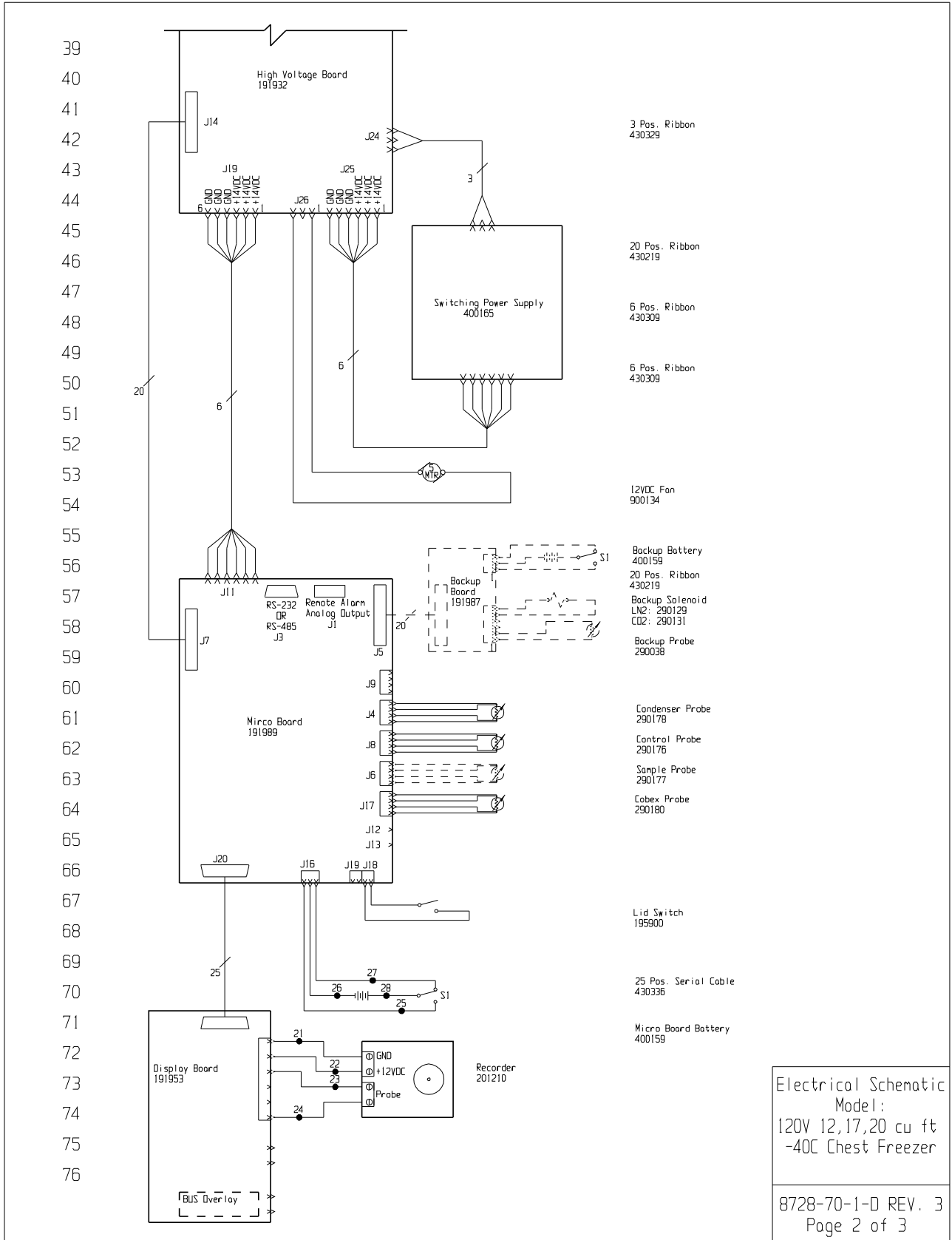

Section 10
Electrical Schematics

	WIRE #	COLOR	GAUGE	WIRE #	COLOR	GAUGE
77	1	BLK	14	29		
78	2	RED	14	30		
	3	GRN/YEL	14	31	GRN/YEL	14
79	4			32	BLK	14
	5			33	BLU	14
80	6	BLK	18	34	BLK	14
	7	BLK	18	35	BLU	14
81	8	BLK	18	36	BLK	14
	9	BLK	18	37	BLU	14
82	10			38	BLK	14
	11			39	BLU	14
83	12			40	BLK	14
	13			41	BLU	14
84	14	GRN/YEL	18	42	BLK	14
	15	GRN/YEL	18	43	BLU	14
85	16			44	-	-
	17	GRN/YEL	14	45	-	-
86	18			46	-	-
	19			47	-	-
87	20	BLK	14	48	-	-
	21	BLK	18	49	-	-
88	22	RED	18	50	-	-
	23	BLK	18	51	-	-
89	24	RED	18	52	-	-
	25	WHT	18	53	YEL	-
90	26	BLK	18	54	-	-
	27	BLK	18	55	BLU	-
91	28	RED	18			

CHEST MODELS:
12.7 CU.FT. - 5315, 8728, 8756, 8779
17 CU.FT. - 5318, 8730, 8757, 8780
20 CU.FT. - 5321, 8737, 8762, 8785

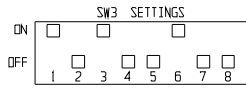

RS-232 SPECIFICATION

BAUD = 1200
PARITY = N
BITS = 8
STOP BITS = 2

REMOTE CONTACTS/ANALOG OUTPUT
PIN# 1 Analog Output +
PIN# 2 Analog Output -
PIN# 3 Not Connected
PIN# 4 Not Connected
PIN# 5 Normally Closed
PIN# 6 Common
PIN# 7 Normally Open

RS-232 PORT
PIN# 2 TXD
PIN# 3 RXD
PIN# 5 GND

CONTACT RATING: 1A @ 30V
CONTACTS IN ALARM STATE

SW1 Settings for Analog Output

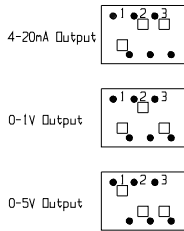

SW2 Settings for Communication Output

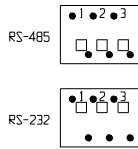

1. Door switch shown in open position.
2. Battery switch shown in the OFF position.
3. Circuit breaker switch shown in OFF position.
4. Options and accessories shown in dashed lines.

REV	ECN NO.	DATE	BY	CAD	APPD	DESCRIPTION OF REVISION
3	FR-2386	08-29-12	AJC	SAG	CCS	REVISED OPERATING RANGE FROM 108-130V
2	FR-2386	07-27-12	MAN	KDG	MSB	CHG. 300421 START RELAY TO 30042B
1	FR-2267	10/26/11	JWE	SAG	DRP	COMPRESSOR CHANGE / RELEASE 7
0	FR-2202	05/03/11	SRS	SAG	LON	RELEASED FOR PRODUCTION / RELEASE 6

Electrical Schematic
Model:
120V 12,17,20 cu ft
-40C Chest Freezer

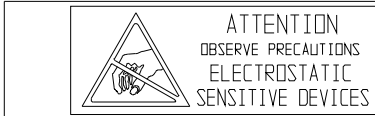

THIS DOCUMENT CONTAINS PROPRIETARY INFORMATION AND SUCH INFORMATION IS NOT TO BE DISCLOSED TO OTHERS FOR ANY PURPOSE NOR USED FOR MANUFACTURING PURPOSES WITHOUT WRITTEN PERMISSION FROM THERMO FISHER SCIENTIFIC

MODEL/PART NAME: 12,17,20CF -40° CHEST FREEZERS, 120V
DWG TITLE: UNIT SCHEMATIC
OWN: HCE CAD: KDG APPD: LON DATE: 10-10-10 SCALE: NONE

ThermoFisher SCIENTIFIC
BOX 649, MARIETTA, OHIO 45750

MATERIAL:
PAINT COLOR:
TOLERANCE UNLESS OTHERWISE SPECIFIED
ANGLES: DECIMAL: .XX±
 : XXX±

DRAWING NUMBER: 8728-70-1
SIZE: D

8728-70-1-D REV. 3
Page 3 of 3

THERMO FISHER SCIENTIFIC FREEZER WARRANTY

The Warranty Period starts two weeks from the date your equipment is shipped from our facility. This allows for shipping time so the warranty will go into effect at approximately the same time your equipment is delivered. The warranty protection extends to any subsequent owner during the warranty period.

During the first two years of the warranty period, component parts proven to be non-conforming in materials or workmanship will be repaired or replaced at Thermo's expense, labor included. The ULT Freezers include an additional two year warranty on the compressors, parts only, F.O.B. factory. Installation and calibration is not covered by this warranty agreement. The Technical Services Department must be contacted for warranty determination and direction prior to any work being performed. Expendable items, i.e., glass, filters, pilot lights, light bulbs and door gaskets are excluded from this warranty.

In addition to the standard warranty, the foamed-in-place cabinet design carries a unit production lifetime warranty (foamed-in-place cabinet, evaporator and foamed-in-place door; parts only). Please contact your sales representative or Thermo for additional information.

Replacement or repair of component parts or equipment under this warranty shall not extend the warranty to either the equipment or to the component part beyond the original two year warranty period. The Technical Services Department must give prior approval for the return of any components or equipment.

THIS WARRANTY IS EXCLUSIVE AND IN LIEU OF ALL OTHER WARRANTIES, WHETHER WRITTEN, ORAL, OR IMPLIED. NO WARRANTIES OF MERCHANTABILITY OR FITNESS FOR A PARTICULAR PURPOSE SHALL APPLY.
Thermo shall not be liable for any indirect or consequential damages including, without limitation, damages relating to lost profits or loss of products.

Your local Thermo Sales Office is ready to help with comprehensive site preparation information before your equipment arrives. Printed instruction manuals carefully detail equipment installation, operation, and preventive maintenance.

If equipment service is required, please call your Technical Services Department at 1-800-438-4851 (USA and Canada) or 1-740-373-4763. We're ready to answer your questions on equipment warranty, operation, maintenance, service, and special applications. Outside the USA, contact your local distributor for warranty information.



Rev. 0 6/11

THERMO FISHER SCIENTIFIC FREEZER INTERNATIONAL DEALER WARRANTY

The Warranty Period starts two months from the date your equipment is shipped from our facility. This allows for shipping time so the warranty will go into effect at approximately the same time your equipment is delivered. The warranty protection extends to any subsequent owner during the warranty period. Dealers who stock our equipment are allowed an additional four months for delivery and installation, providing the warranty card is completed and returned to the Technical Services Department.

During the first two years of the warranty period, component parts proven to be non-conforming in materials or workmanship will be repaired or replaced at Thermo's expense, labor excluded. The ULT Freezers include an additional two year warranty on the compressors, parts only, F.O.B. factory. Installation and calibration is not covered by this warranty agreement. The Technical Services Department must be contacted for warranty determination and direction prior to any work being performed. Expendable items, i.e., glass, filters, pilot lights, light bulbs and door gaskets are excluded from this warranty.

In addition to the standard warranty, the foamed-in-place cabinet design carries a unit production lifetime warranty (foamed-in-place cabinet, evaporator and foamed-in-place door; parts only). Please contact your sales representative or Thermo for additional information.

Replacement or repair of component parts or equipment under this warranty shall not extend the warranty to either the equipment or to the component part beyond the original two year warranty period. The Technical Services Department must give prior approval for the return of any components or equipment.

THIS WARRANTY IS EXCLUSIVE AND IN LIEU OF ALL OTHER WARRANTIES, WHETHER WRITTEN, ORAL, OR IMPLIED. NO WARRANTIES OF MERCHANTABILITY OR FITNESS FOR A PARTICULAR PURPOSE SHALL APPLY.

Thermo shall not be liable for any indirect or consequential damages including, without limitation, damages relating to lost profits or loss of products.

Your local Thermo Sales Office is ready to help with comprehensive site preparation information before your equipment arrives. Printed instruction manuals carefully detail equipment installation, operation, and preventive maintenance.

If equipment service is required, please contact your local distributor or Thermo (1-800-438-4851 in USA and Canada, or 1-740-373-4763). We're ready to answer your questions on equipment warranty, operation, maintenance, service, and special applications. Outside the USA, contact your local distributor for warranty information.



Rev. 0 6/11

Appendix A Handling Liquid Nitrogen



Warning Contact of liquid nitrogen or cold gas with the skin or eyes may cause serious freezing (frostbite) injury. ▲

Handle liquid nitrogen carefully.

The extremely low temperature can freeze human flesh very rapidly. When spilled on a surface the liquid tends to cover it completely and intimately, cooling a large area. The gas issuing from the liquid is also extremely cold. Delicate tissue, such as that of the eyes, can be damaged by an exposure to the cold gas which would be too brief to affect the skin of the hands or face.

Never allow any unprotected part of your body to touch objects cooled by liquid nitrogen.

Such objects may stick fast to the skin and tear the flesh when you attempt to free yourself. Use tongs to withdraw objects immersed in the liquid, and handle the object carefully.

Wear protective clothing.

Protect your eyes with a face shield or safety goggles (safety glasses without side shields do not give adequate protection). Always wear gloves when handling anything that is, or may have been, in immediate contact with liquid nitrogen. Insulated gloves are recommended, but heavy leather gloves may also be used. The gloves should fit loosely, so that they can be thrown off quickly if liquid should splash into them. When handling liquid in open containers, it is advisable to wear high-top shoes. Trousers (which should be cuffless if possible) should be worn outside the shoes.

Introduction

The safe handling and use of liquid nitrogen in cryogenic refrigerators and dewar flasks is largely a matter of knowing the potential hazards and using common-sense procedures based on that knowledge. There are two important properties of liquid nitrogen that present potential hazards:

1. It is extremely cold. At atmospheric pressure, liquid nitrogen boils at -320°F (-196°C).
2. Very small amounts of liquid vaporize into large amounts of gas. One liter of liquid nitrogen becomes 24.6 cu. ft. (700l) of gas.

The safety precautions in this booklet must be followed to avoid potential injury or damage which could result from these two characteristics. Do not attempt to handle liquid nitrogen until you read and fully understand the potential hazards, their consequences, and the related safety precautions. Keep this booklet handy for ready reference and review.

Note Because argon is an inert gas whose physical properties are very similar to those of nitrogen, precautions and safe practices for the handling and use of liquid argon are the same as those for liquid nitrogen. ▲

Use only containers designed for low temperature liquids.

Cryogenic containers are specifically designed and made of materials that can withstand the rapid changes and extreme temperature differences encountered in working with liquid nitrogen. Even these special containers should be filled SLOWLY to minimize the internal stresses that occur when any material is cooled. Excessive internal stresses can damage the container.

Do not cover or plug the entrance opening of any liquid nitrogen refrigerator or dewar. Do not use any stopper or other device that would interfere with venting of gas.

These cryogenic liquid containers are generally designed to operate with little or no internal pressure. Inadequate venting can result in excessive gas pressure which could damage or burst the container. Use only the loose-fitting necktube core supplied or one of the approved accessories for closing the necktube. Check the unit periodically to be sure that venting is not restricted by accumulated ice or frost.

Use proper transfer equipment.

Use a phase separator or special filling funnel to prevent splashing and spilling when transferring liquid nitrogen into or from a dewar or refrigerator. The top of the funnel should be partly covered to reduce splashing. Use only small, easily-handled dewars for pouring liquid. For the larger, heavier containers, use a cryogenic liquid withdrawal device to transfer liquid from one container to another. Be sure to follow instructions supplied with the withdrawal device. When liquid cylinders or other large storage containers are used for filling, follow the instructions supplied with those units and their accessories.

Do not overfill containers.

Filling above the bottom of the necktube (or specified maximum level) can result in overflow and spillage of liquid when the necktube core or cover is placed in the opening.

Never use hollow rods or tubes as dipsticks.

When a warm tube is inserted into liquid nitrogen, liquid will spout from the top of the tube due to gasification and rapid expansion of liquid inside the tube.



Warning Nitrogen gas can cause suffocation without warning! ▲

Store and use liquid nitrogen only in a well-ventilated place.

As the liquid evaporates, the resulting gas tends to displace the normal air from the area. In closed areas, excessive amounts of nitrogen gas reduce the concentration of oxygen and can result in asphyxiation. Because nitrogen gas is colorless, odorless and tasteless, it cannot be detected by the human senses and will be breathed as if it were air. Breathing an atmosphere that contains less than 18% oxygen can cause dizziness and quickly result in unconsciousness and death.

Note The cloudy vapor that appears when liquid nitrogen is exposed to the air is condensed moisture; not the gas itself. The issuing gas is invisible. ▲

Never dispose of liquid nitrogen in confined areas or places where others may enter.

Disposal of liquid nitrogen should be performed outdoors in a safe place. Pour the liquid slowly on gravel or bare earth where it can evaporate

Appendix B Handling Liquid CO₂



Warning High concentrations of CO₂ gas can cause asphyxiation! OSHA Standards specify that employee exposure to carbon dioxide in any eight-hour shift of a 40-hour work week shall not exceed the eight-hour time weighted average of 5000 PPM (0.5% CO₂). The short term exposure limit for 15 minutes or less is 30,000 PPM (3% CO₂). Carbon dioxide monitors are recommended for confined areas where concentrations of carbon dioxide gas can accumulate. ▲

Store and use liquid CO₂ only in a well-ventilated place.

As the liquid evaporates, the resulting gas tends to displace the normal air from the area. In closed areas, excessive amounts of CO₂ gas reduce the concentration of oxygen and can result in asphyxiation. Because CO₂ gas is colorless, odorless and tasteless, it cannot be detected by the human senses and will be breathed as if it were air. Breathing an atmosphere that contains less than 18% oxygen can cause dizziness and quickly result in unconsciousness and death.

Note The cloudy vapor that appears when liquid CO₂ is exposed to the air is condensed moisture; not the gas itself. The issuing gas is invisible. ▲

Never dispose of liquid CO₂ in confined areas or places where others may enter.

Disposal of liquid CO₂ should be done outdoors in a safe place. Pour the liquid slowly on gravel or bare earth where it can evaporate without causing damage. Do not pour the liquid on pavement.

Appendix C First Aid

If a person seems to become dizzy or loses consciousness while working with liquid nitrogen or carbon dioxide, move to a well-ventilated area immediately. If breathing has stopped, apply artificial respiration. If breathing is difficult, give oxygen. Call a physician. Keep warm and at rest.

If exposed to liquid or cold gas, restore tissue to normal body temperature (98.6°F) as rapidly as possible, followed by protection of the injured tissue from further damage and infection. Remove or loosen clothing that may constrict blood circulation to the frozen area. Call a physician. Rapid warming of the affected part is best achieved by using water at 108°F. Under no circumstance should the water be over 112°F, nor should the frozen part be rubbed either before or after rewarming. The patient should neither smoke nor drink alcohol.

thermoscientific.com

© 2014 Thermo Fisher Scientific Inc. All rights reserved. All trademarks are the property of Thermo Fisher Scientific and its subsidiaries. Specifications, terms and pricing are subject to change. Not all products are available in all countries. Please consult your local sales representative for details.

Thermo Fisher Scientific
401 Millcreek Road
Marietta, Ohio 45750
United States

Thermo
S C I E N T I F I C
A Thermo Fisher Scientific Brand