



CAN DIEN TU TAN HIEP THANH

FM Mini-indicator



User Manual

© Excell Precision Limited 2006. All rights reserved Worldwide.

The information contained herein is the property of Excell Precision Limited and is supplied without liability for errors or omissions. No part may be reproduced or used except as authorised by contract or other written permission. The copyright and the foregoing restriction on reproduction and use extend to all media in which the information may be embodied.

www.tanhiepthanh.com.vn



CAN DIEN TU TAN HIEP THANH TABLE OF CONTENT

SAFETY PRECAUTION..... 3

<CHAPTER 1> FEATURES AND SPECIFICATION..... 4

 1-1 FEATURES..... 4

 1-2 SPECIFICATION 5

<CHAPTER 2> KEYPAD OPERATION INSTRUCTION 6

<CHAPTER 3> FRONT & REAR PANELS..... 7

 3-1 FRONT PANEL 7

 3-2 REAR PANEL..... 8

<CHAPTER 4> INSTALLATION..... 9

 4-1 LOAD CELL 9

 4-2 DIMENSION..... 10

 4-3 BATTERY ASSEMBLY 11

<CHAPTER 5> INTERNAL CALIBRATION 12

 5-1 SPECIFICATION SETTING 01 [SP]..... 13

 2 *Specification Parameter Description* 14

 2 *Parameter Display Description* 15

 5-2 INTERNAL WEIGHT CALIBRATION 02 [CAL]..... 16

 2 *Password Setting*..... 17

 5-3 INTERNAL FUNCTION SETTING 04 [Fn]..... 18

 2 *Internal Function Parameter Description* 19

 2 *Error Message*..... 20

<CHAPTER 6> SPECIAL FUNCTION 21

 6-1 ANIMAL SCALE FUNCTION SETTING 21

 6-2 DUAL RANGE RESOLUTION SWITCH FUNCTION 22

 6-3 PRE-TARE FUNCTION 23

 6-4 RESOLUTION SWITCH FUNCTION..... 23



<CHAPTER 7> TRANSMISSION INTERFACE 24

7-1 OP-01 RS232 / RS485 SERIAL OUTPUT (WITH RTC)..... 24

 2 Pin Allocation of Rear Panel..... 24

 2 Connection Description (RS485)..... 25

<CHAPTER 8> FUNCTION PARAMETER SETTING 26

8-1 FUNCTION SETTING **01 Fnc** 27

 2 Function Parameter Setting..... 28

8-2 RS232 SETTING **03 r5 l** 29

 2 OP-01 RS232 / RS485 Interface Function..... 30

 2 Transmission Format..... 32

 2 Command Mode..... 33

<CHAPTER 9> MAINTENANCE 34

9-1 DEFAULT RECOVERY FOR ALL PARAMETERS..... 34

9-2 DEFAULT RECOVERY FOR GENERAL FUNCTION PARAMETERS 34

9-3 SELF-DIAGNOSIS MODE..... 34

 9-3-1 Program Version Number..... 35

 9-3-2 7-segment Display Testing..... 35

 9-3-3 Keypad & Calibration Switch Testing..... 35

 9-3-4 AD Conversion Value..... 35

 9-3-5 EEPROM Testing..... 35

 9-3-6 RTC Time & Date Testing..... 35

 9-3-7 RS-232 Serial Output Interface Testing (OP-01)..... 35

CAN DIEN TU TAN HIEP THANH

BEFORE USING THE INDICATOR

Thanks for purchasing **EXCELL FM Mini-indicator**. In order to operate smoothly, to last the durability, and to reduce the chance of breakdown for this product, please read the following instructions carefully.

Safety Precaution

- & Turn off power before installing or disassembling.
- & Keep the product away from sunshine. The temperature range for operation is $-10^{\circ}\text{C} \sim +40^{\circ}\text{C}$.
- & To connect the ground is a must for this equipment. The ground impedance is less than 100Ω .
- & Never connect the ground with other equipments which are huge in power consumption.
- & No ground or incorrect ground connecting might cause the electric shocks or breakdowns.



CAN DIEN TU TAN HIEP THANH

<Chapter 1> Features and Specification

1-1 Features

- I Large and clear LCD (height 25.4mm × 10mm)
- I LED Backlight, more duration, more energy saving
- I Auto zero tracking
- I Weighing calibration in both kilogram and pound
- I High resolution switch function to display 10 times divisions
- I Weighing unit shift function & data accumulation function
- I Adjustable digital filter
- I Available in connecting with up to four 350-ohm load cells
- I Capable of connecting with 6-wire load cells
- I Convenient to operate power switch in front panel



CAN DIEN TU TAN HIEP THANH

1-2 Specification

Analog Specification

- ◆ Load Cell Current: DC 5V \pm 5% 60mA (Up to Four 350 Ω Load Cells)
- ◆ Max. Load Cell Input Voltage: 16 mV
- ◆ Input Sensitivity: 0.12 μ V/D or more
- ◆ Conversion Rate: Approximately 100 times/sec. (max.)
- ◆ Resolution: 19 bits

Digital Specification

- ◆ Display: LCD, 6 digits, height 25.4x10mm, LED backlight
- ◆ Display Frequency: 50 times/sec. (max.)
- ◆ Display Range: - 999999 ~ 999999
- ◆ Min. Division: 1, 2, 5, 10, 20, 50
- ◆ Decimal Point: 0, 0.0, 0.00, 0.000, 0.0000
- ◆ Memory: Calibration parameter and function setting are all stored in EEPROM.

Optional Interface

- ◆ OP-01 RS-232 / RS-485 (Includes RTC Function)

Power Requirement







- ◆ Adaptor Spec.: Input 120/230VAC 50~60Hz, output 9V/1000mA
- ◆ 6V/5pcs Hi-MH rechargeable battery kit (1800mA/1hr)
- ◆ Max. Power Consumption (by rechargeable battery):
120mA (with 4 Load Cells + backlight + RS-232 interface) →15 hours
50mA (with 1 Load Cell + no backlight + no RS-232 interface) →36 hours

Others

- ◆ Operation Temperature: -10 $^{\circ}$ C ~ 40 $^{\circ}$ C
- ◆ Operation Humidity: < 85% R.H.
- ◆ Dimension: W 49.5 \times L193 \times H134 (mm)
- ◆ Weight: 700 (g)

CAN DIEN TU TAN HIEP THANH

<Chapter 2> Keypad Operation Instruction

Function	Operation	Description
General Function Setting	Press and hold  , and then press 	Refer to <Chapter 8> Function Parameter Setting for details
Weighing Parameter Setting	Adjust calibration switch to ON	Setting for decimal point, capacity, division, zero tracking, and unstable detecting, etc. Refer to 5-1 Specification Setting for details.
Calibration	Adjust calibration switch to ON	Refer to 5-2 Internal Weight Calibration for operation.
Self-diagnosis Mode	While turning on with countdown, press and hold 	Refer to 9-3 Self-diagnosis Mode for details.
Default Recover for All Parameters	Adjust calibration switch to ON, and then press and hold  	Refer to 9-1 for details.
Default Recovery for General Function Parameters	While turning on with countdown, press and hold  	Refer to 9-2 for details.

4 During the operation, use the following keys to complete all the works.



⇒ To add the value flashing



⇒ To move the cursor rightward



⇒ To reduce the value flashing



⇒ Storage setting



⇒ To move the cursor leftward



⇒ To abort setting/to escape



CAN DIEN TU TAN HIEP THANH

<Chapter 3> Front & Rear Panels

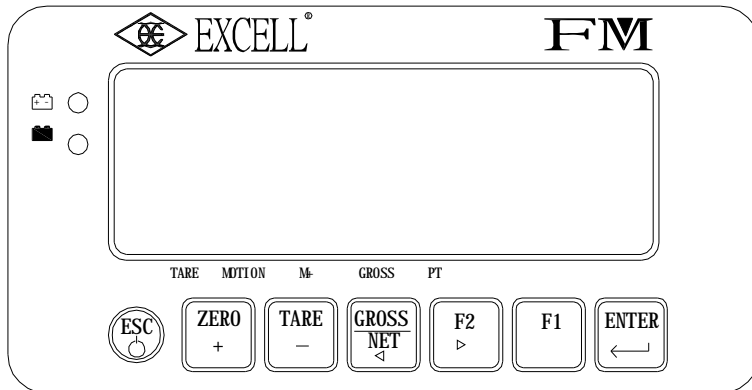





3-1 Front Panel



Indication:

-  : Battery charged status
-  : Battery charging status
- TARE : Tare status
- MOTION : Unstable weighing indication
- M+ : Accumulation status indication
- GROSS : Gross weight
- PT : Pre-tare

Keypad:

-  1) Power ON / OFF. Press and hold this key for 3 seconds to shut down.
2) To abort or escape when setting.
-  1) Weight re-zero.
2) To add the value when setting.
-  1) To eliminate the gross weight.
2) To reduce the value when setting.
-  1) To switch Gross / Net weight shown on display.
2) To move the cursor leftward when setting.
-  1) Keypad function (FNC-02 & FNC-03)
2) To move the cursor rightward when setting.
-  Keypad function (FNC-02 & FNC-03)
-  Confirmation key.

3-2 Rear Panel

CAN DIEN TU TAN HIEP THANH

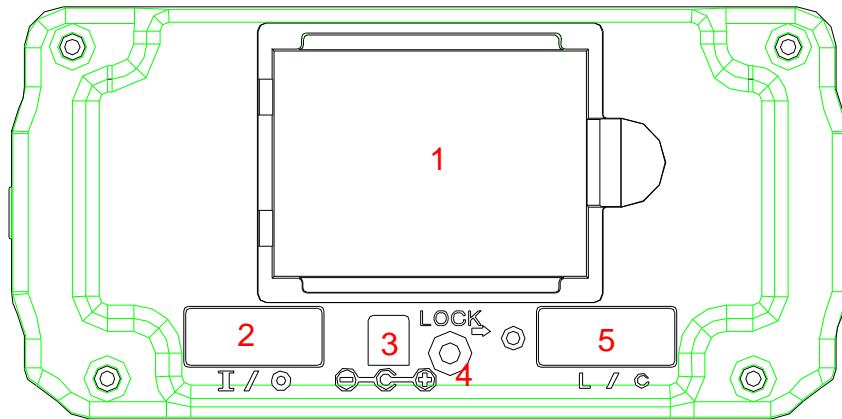

1. Battery Case
2. RS232/485 Input/Output
3. DC 9V Power Input
4. Calibration Switch
5. Load Cell Connect Socket

CAN DIEN TU TAN HIEP THANH

<Chapter 4> Installation

4-1 Load Cell

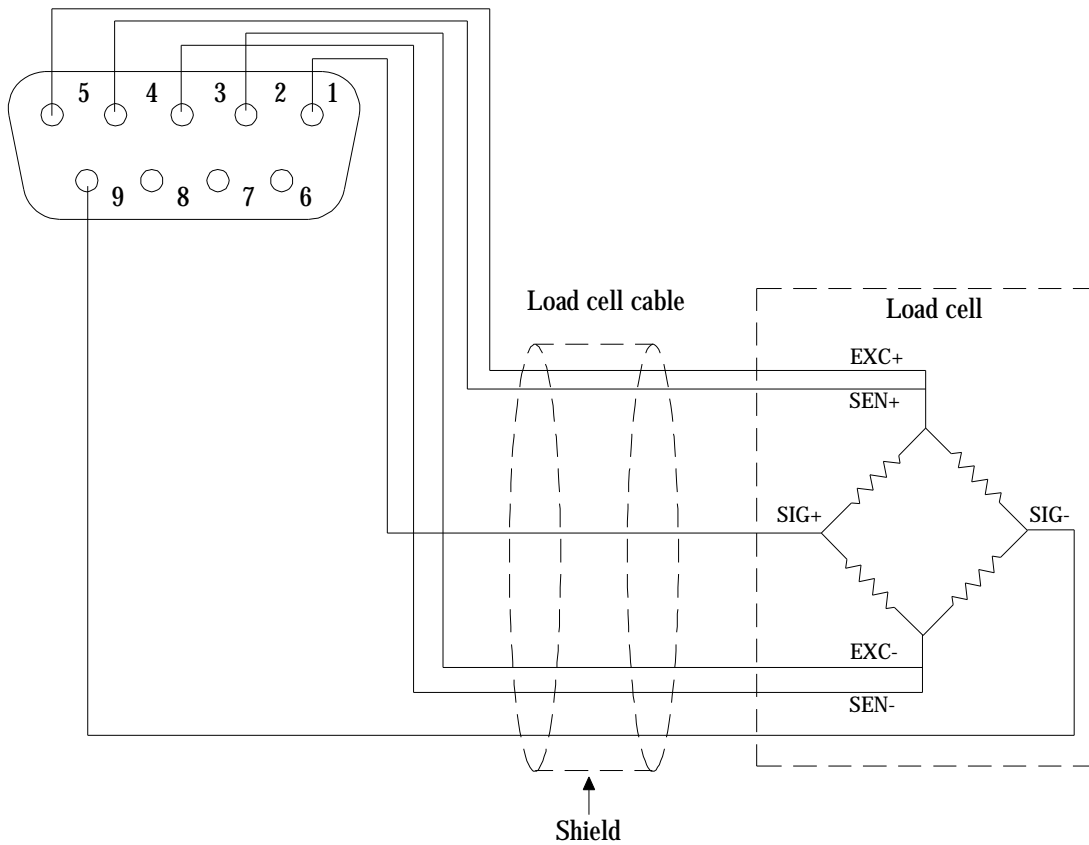

4-wired (5-wired) Load Cell

Short Pin4&5 to connect with EXC+
 Short Pin2&3 to connect with EXC-
 Pin1 connects with SIG+
 Pin9 connects with SIG-
 Pin6, 7, 8 connect with Shield

6-wired (7-wired) Load Cell

Pin5 connects with EXC+
 Pin4 connects with SEN+
 Pin3 connects with EXC-
 Pin2 connects with SEN-
 Pin1 connects with SIG+
 Pin9 connects with SIG-
 Pin6, 7, 8 connect with Shield



CAN DIEN TU TAN HIEP THANH

4-2 Dimension

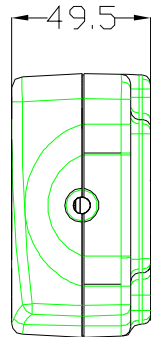
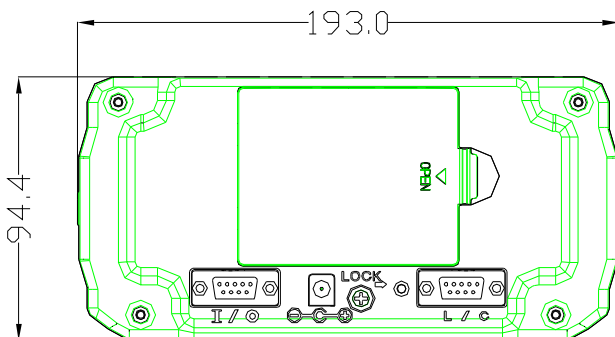
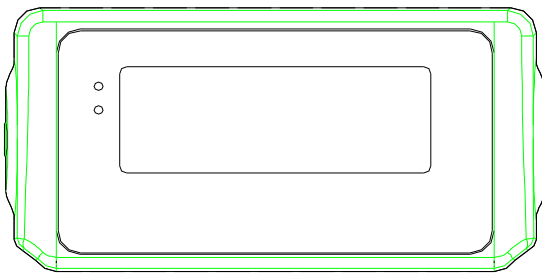
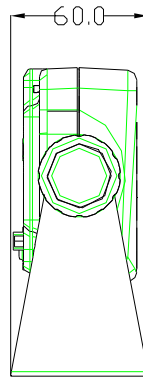
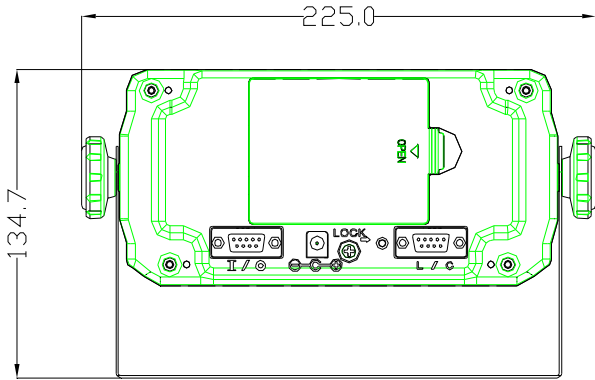
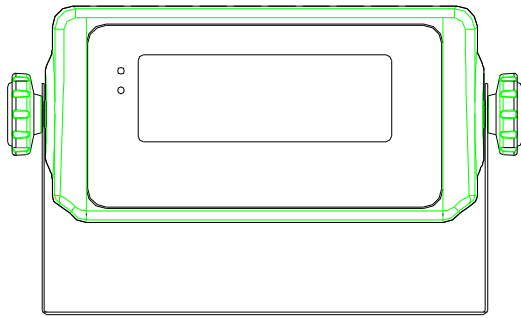
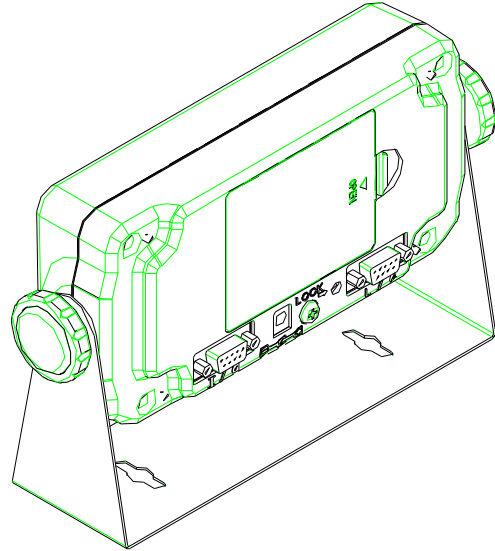

CAN DIEN TU TAN HIEP THANH

4-3 Battery Assembly

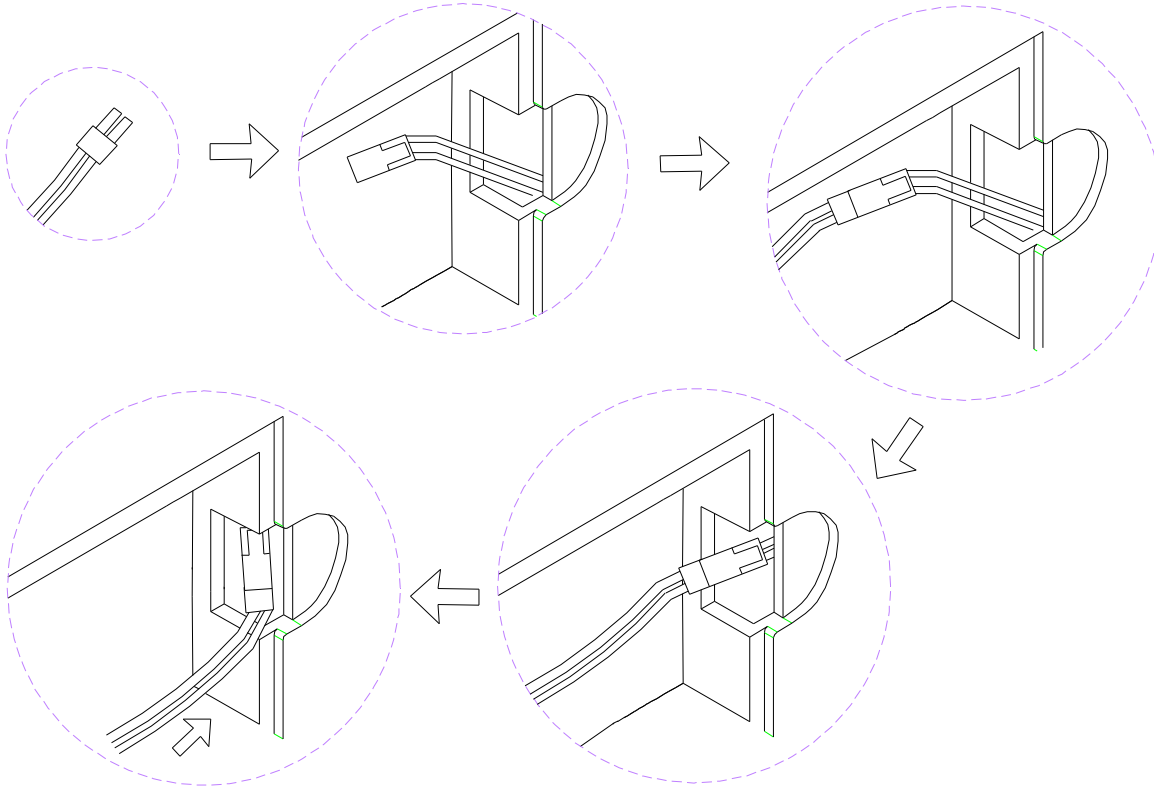

Stuff the surplus wires into the battery case.

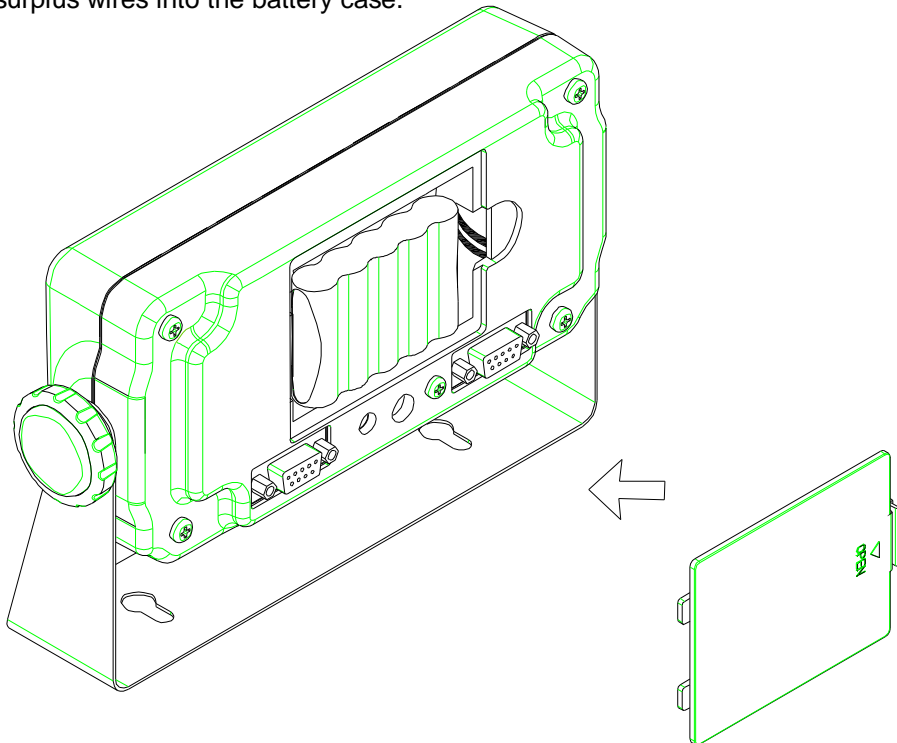

CAN DIEN TU TAN HIEP THANH

<Chapter 5> Internal Calibration

Adjust calibration switch to “ON”, and the screen displays:

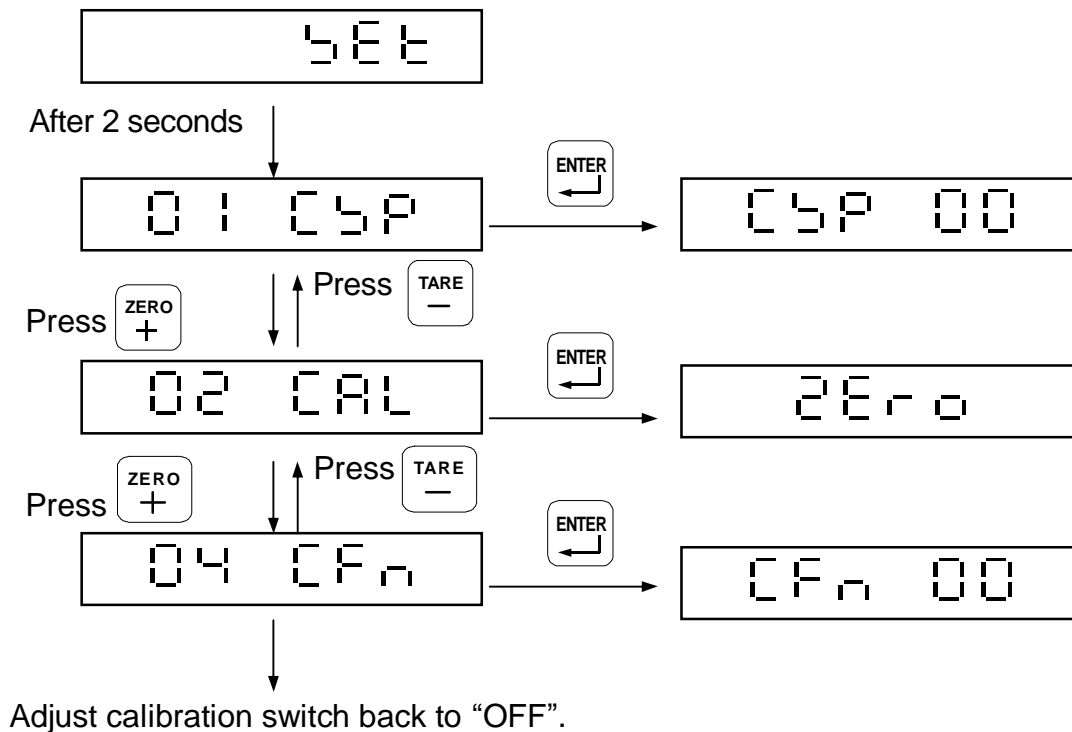

01 C5P ⇒ Specification Setting

02 CAL ⇒ Internal Weight Calibration

04 CFn ⇒ Internal Function Setting

CAN DIEN TU TAN HIEP THANH

5-1 Specification Setting 01 C5P

01 C5P

Press 

C5P-00

Input the *Parameter Code intended

C5P-04

Press 

000000

The screen displays the parameters set previously. Input the parameters intended and then press 

C5P-05

Continue other functions setting or press  to escape.

*Parameter Code

C5P-00 ⇒ Decimal Point







C5P-01 ⇒ Capacity

C5P-02 ⇒ Division 1

C5P-03 ⇒ Division 2

C5P-04 ⇒ Zero Tracking Setting

C5P-05 ⇒ Unstable Detecting Setting

-  ⇒ To add the value flashing
-  ⇒ To reduce the value flashing
-  ⇒ To move the cursor leftward
-  ⇒ To move the cursor rightward
-  ⇒ Storage setting
-  ⇒ To abort setting / escape

**CAN DIEN TU TAN HIEP THANH****2 Specification Parameter Description**

Parameter Code	Function	Setting		Default Setting
		Parameter	Description	
CSP-00	Decimal Point		Refer to the description on next page.	
CSP-01	Capacity	999999 ↓ 000000	Max. value for weight display	999999
CSP-02	Division 1	1	Min. value for weight display	1
		2		
		5		
		10		
		20		
		50		
CSP-03	Division 2	1	Min. value for Weight display	1
		2		
		5		
		10		
		20		
		50		
CSP-04	Zero Tracking Setting		Refer to the description on next page.	
CSP-05	Unstable Detecting Setting		Refer to the description on next page.	

CAN DIEN TU TAN HIEP THANH

2 Parameter Display Description

CSP-00 Decimal Point

Display	Decimal Point Digit
d 0	None
d 00	1 Digit
d 000	2 Digits
d 0000	3 Digits
d 00000	4 Digits

CSP-04 Zero Tracking Setting

Display	Division/Period
0.25 d	0.25 D/1 sec
0.5 d	0.5 D/1 sec
0.75 d	0.75 D/1 sec
1 d	1D/1 sec
1.25 d	1.25 D/2 sec
1.5 d	1.5 D/2 sec
1.75 d	1.75 D/2 sec
2 d	2 D/2 sec
no	No Zero Tracking

CSP-05 Unstable Detecting Setting

Display	Division / Period
0.25 d	0.25 D/1 sec
0.5 d	0.5 D/1 sec
0.75 d	0.75 D/1 sec
1 d	1D/1 sec
1.25 d	1.25 D/2 sec
1.5 d	1.5 D/2 sec
1.75 d	1.75 D/2 sec
2 d	2 D/2 sec
no	No Unstable Detecting

CAN DIEN TU TAN HIEP THANH

5-2 Internal Weight Calibration 02 CAL

Turn on and warm up the machine for 15 to 30 minutes before calibration.



Adjust calibration switch to “ON”, and the screen will display SET.

Press  or  to select 02 CAL.

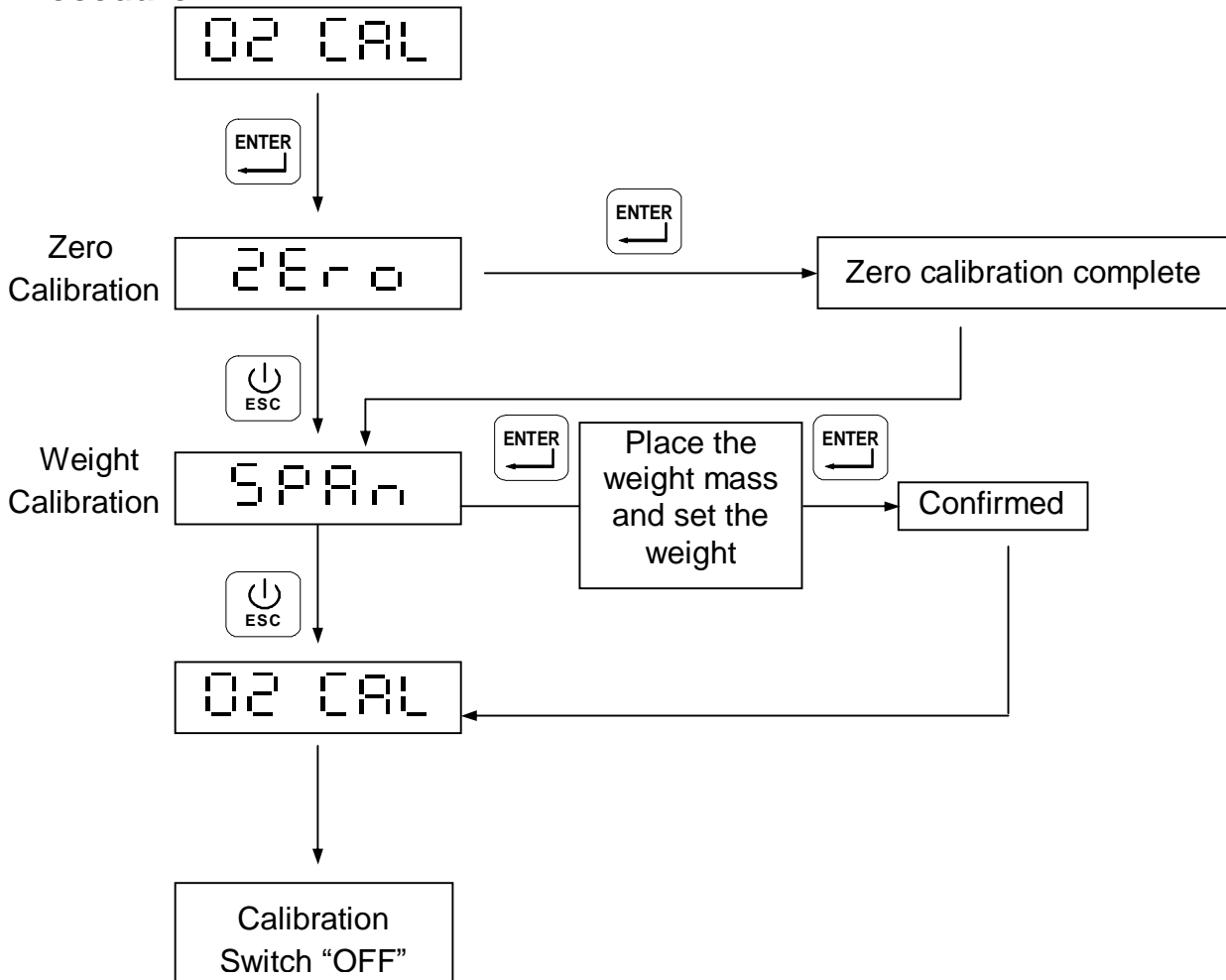

Procedure



Zero Calibration

- Ensure nothing on the platter; after being stable, press , and the screen will display “ ”. The zero calibration will be complete 5 seconds later.
- To abort zero calibration, just press .

Weight Calibration

- Place an object, whose weight is known, on the platter, and input the weight value from front panel. After being stable, press  and the screen will display “ ”. The weight calibration will be complete 5 seconds later.
- To abort weight calibration, just press .

CAN DIEN TU TAN HIEP THANH

2 Password Setting

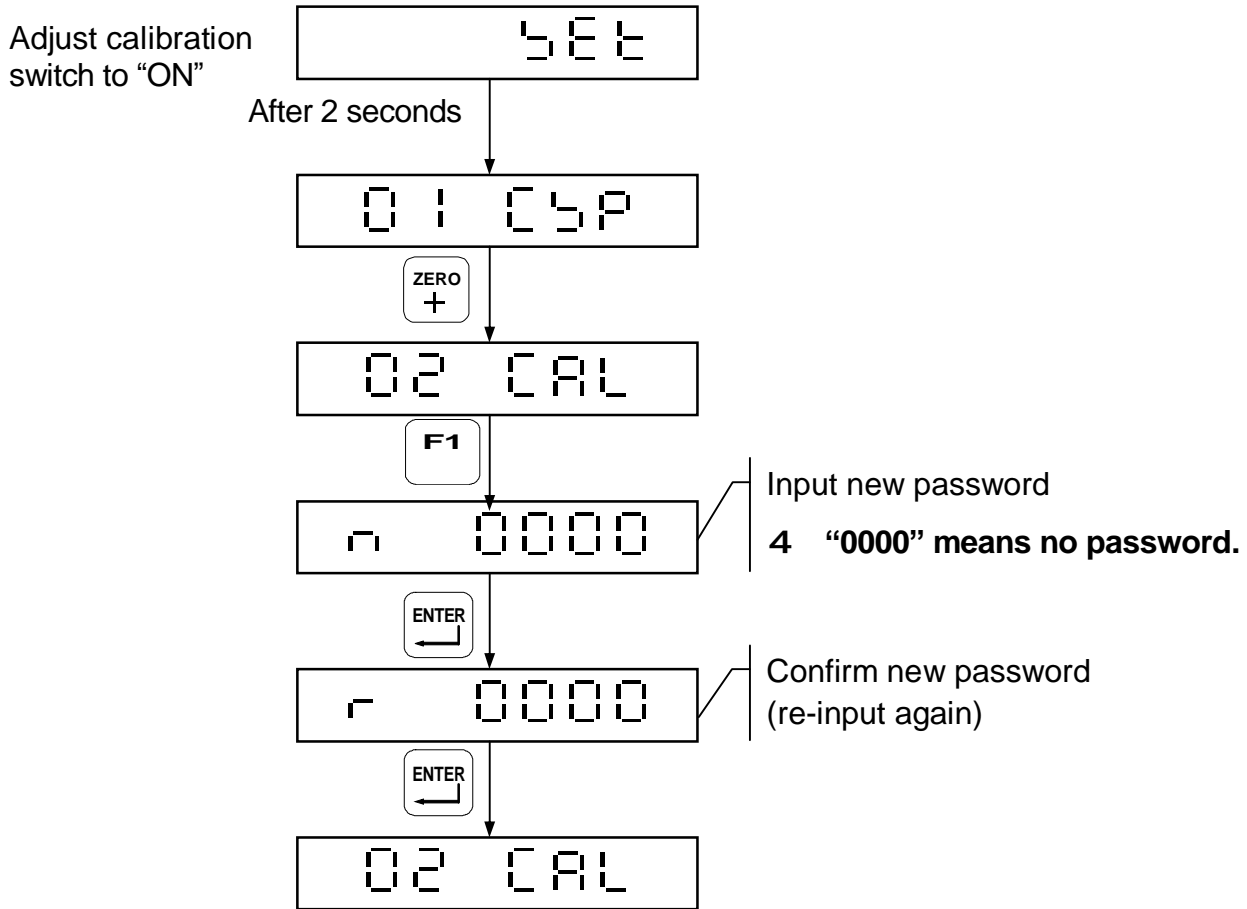

- 4 After complete password setting, when entering calibration mode or function setting mode, the screen displays \bar{F} \bar{r} for 1 second, and then $\bar{0}\bar{0}\bar{0}\bar{0}$. It's necessary to input the correct password to continue each setting.

If the password inputted is not correct, the screen displays \bar{E} \bar{r} \bar{r} .

CAN DIEN TU TAN HIEP THANH

5-3 Internal Function Setting

04 CF_n

04 CF_n

Press 

CF_n-00

Input the *Parameter code intended

CF_n-05

Press 

000000

The screen displays the parameters set previously. Input the parameters intended and then press



CF_n-06

Continue other functions setting or press  to escape.

*Parameter Code

CF_n-00 ⇒ Tare or Zero Function under Unstable Status

CF_n-01 ⇒ Turning on Re-zero

CF_n-02 ⇒ Re-zero Range

CF_n-03 ⇒ Filter Strength

CF_n-04 ⇒ AD Sampling Rate

CF_n-05 ⇒ Animal Scale Mode

CF_n-06 ⇒ Animal Scale Stable Range

CF_n-07 ⇒ Animal Scale Sampling Frequency

CF_n-08 ⇒ Dual Range Resolution Setting

CF_n-09 ⇒ Dual Range Resolution Middle Point Setting

 ⇒ To add the value flashing

 ⇒ To reduce the value flashing

 ⇒ To move the cursor leftward

 ⇒ To move the cursor rightward

 ⇒ Storage setting

 ⇒ To abort setting / escape

CAN DIEN TU TAN HIEP THANH

2 Internal Function Parameter Description

Parameter Code	Function	Setting		Default Setting
		Parameter	Description	
CFN-00	Tare or Zero Function under Unstable Status	0	ON	0
		1	OFF	
CFN-01	Re-zeroing after Turning on	0	OFF	0
		1	ON	
CFN-02	Re-zero Range	0% ~ 30%	0%: Full range re-zero 1% ~ 30%: Capacity × ± setting value%	0
CFN-03	Filter Strength	0 ~ 5	Strength increases by number	2
CFN-04	AD Sampling Rate	0	No limit	2
		1	20 times/sec.	
		2	10 times/sec.	
		3	5 times/sec.	
CFN-05	Animal Scale Mode	0	OFF	0
		1	Mode 1: No weight display under unstable status	
		2	Mode 2: Weight display whether under stable or unstable status	
CFN-06	Animal Scale Stable Range	0 ~ 100	Mode 2: Stable Range Setting	30
CFN-07	Animal Scale Sampling Frequency	0	8 times	2
		1	16 times	
		2	32 times	
		3	64 times	
		4	128 times	
CFN-08	Dual Range Resolution Setting	0	Multi-interval	0
		1	Multi-range	
CFN-09	Dual Range Resolution Middle Point Setting	0 ~ 65535		5000

CAN DIEN TU TAN HIEP THANH

2 Error Message

- (1) E r r 0 Load Cell or A/D circuit extraordinary
- (2) E r r 2 Real weighing value \leq zero value
- (3) E r r 5 Internal resolution $<$ 0.12 μ V/D range
- (4) E r r . Incorrect password
- (5) E | Turning on zero \leq zero range
- (6) E 2 Turning on zero \geq zero range

CAN DIEN TU TAN HIEP THANH

<Chapter 6> Special Function

6-1 Animal Scale Function Setting

2 CFN-05 = 1 (Animal Scale Mode1: No weight display under unstable status)

When no any object is on the platter, the screen will display:

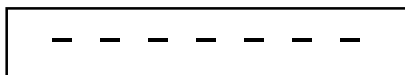

When the object is on the platter, after weight has been measured, the screen will display:

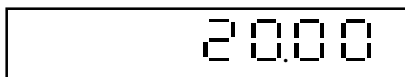

If the display weight value keeps being lower than zero plus 10d, the screen will display:

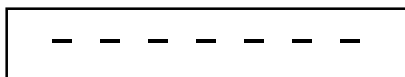

2 CFN-05 = 2 (Animal Scale Mode 2: Weight display weather under unstable or stable status)

When the weight value reaches the range of CFN-06 and CFN-07 setting, the screen will keep displaying the weight value.

When the weight value is over the range of CFN-06 and CFN-07 setting, the screen will display the normal weight measurement.

Example: CFN-06=30 CFN-07=2

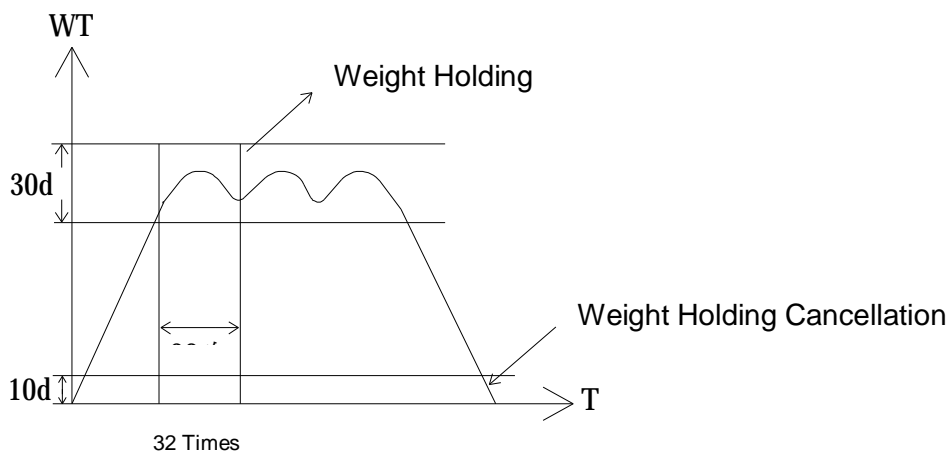

CAN DIEN TU TAN HIEP THANH

6-2 Dual Range Resolution Switch Function

If the setting of CSP-02 is not the same as CSP-03, the dual range resolution will be activated.

2 CFN-08 = 0 ⇒ Multi-interval

If CFN-09 = 5000

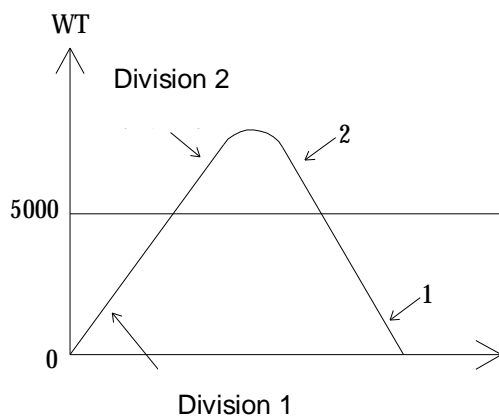

2 CFN-08 = 1 ⇒ Multi-range

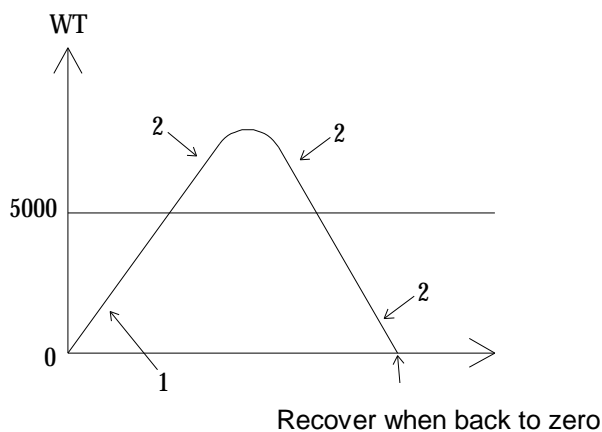

If CFN-09 = 5000



CAN DIEN TU TAN HIEP THANH

6-3 Pre-tare Function

2 FNC-02 or FNC-03 setting is at parameter 6. (Pre-tare Function)

Under weight display status, press  or  key (according to FNC setting), the screen will display:

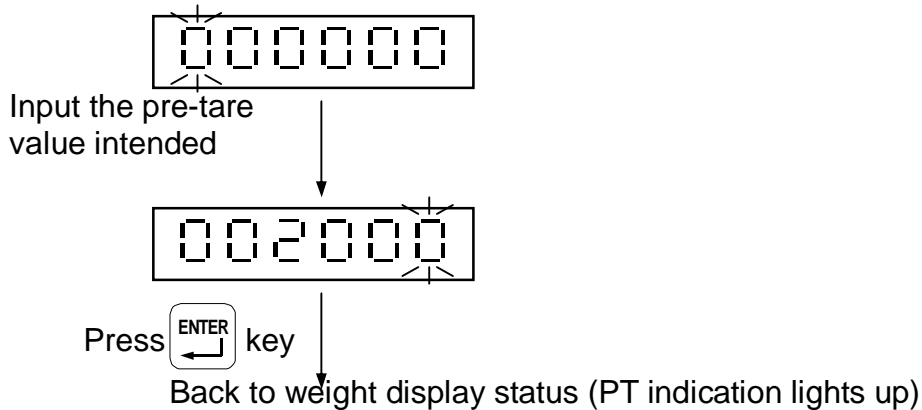



Pre-tare Cancellation

When the gross weight is displayed as “0”, press  key to cancel the pre-tare value.

6-4 Resolution Switch Function

2 FNC-02 or FNC-03 setting is at parameter 5. (HR)

Under weight display status, press  or  key (according to FNC setting), the screen will display 10 times resolution, and then, recovery back to original after 5 seconds.

CAN DIEN TU TAN HIEP THANH

<Chapter 7> Transmission Interface

7-1 OP-01 RS232/RS485 Serial Output (with RTC)

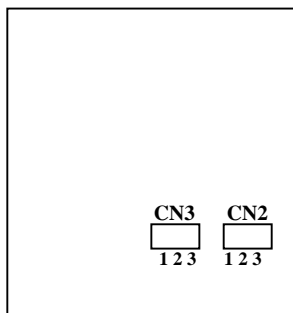

To short 1 and 2 pins is RS485 output.
To short 2 and 3 pins is RS232 output.

2 Pin Allocation of Rear Panel

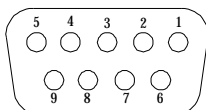

Pin	Function
2	RXD
3	TXD
5	SG
6	DA
7	DB

4 RS485 interface is capable to connect up to 10 mini-indicators.

2 Connection Description (RS485)

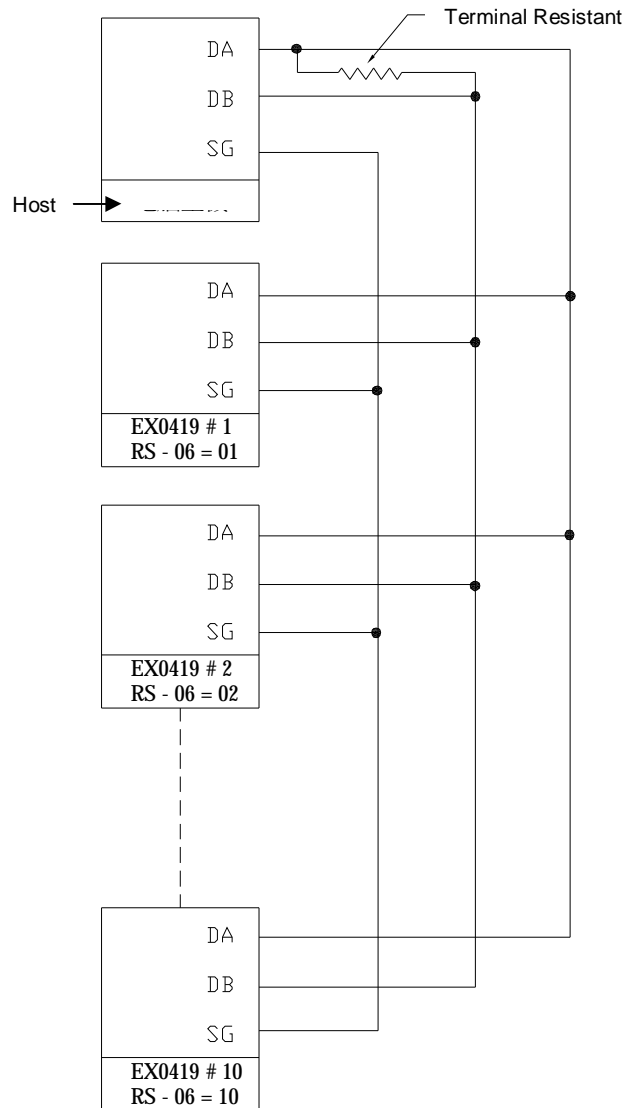

4 Notice

- ◆ If the terminal resistant is built-in the host interface, it's not necessary to connect with another one outside.
- ◆ If the host computer is no signal ground (SG), it's not necessary to connect with it.

CAN DIEN TU TAN HIEP THANH

<Chapter 8> Function Parameter Setting

Under general weight display status, press **F1** **ENTER**, and the screen will display:

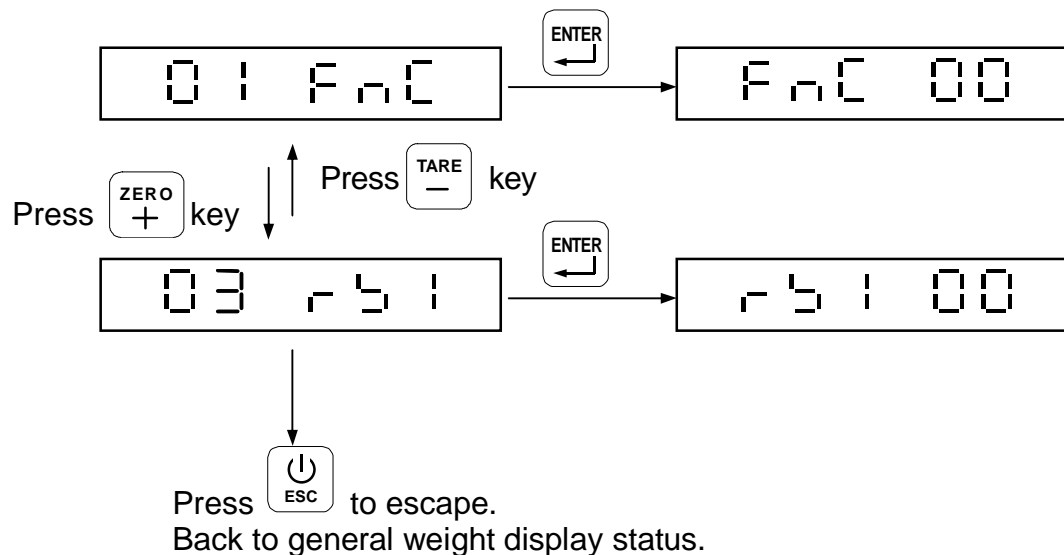

01 Fnc ⇒ External function setting

03 r51 ⇒ RS232/RS485 interface function

CAN DIEN TU TAN HIEP THANH

8-1 Function Setting 01 Fnc

01 Fnc

Press 

Fnc-00

Input the *parameter code intended

Fnc-01

Press 

000000

The screen displays the parameters set previously. Input the parameters intended and then press .

Fnc-02

Continue other function settings

or press  to escape

*Parameter Code







Fnc-00 ⇒ Key Disable

Fnc-01 ⇒ DSP Update

Fnc-02 ⇒ F1 Key Function Setting





Fnc-03 ⇒ F2 Key Function Setting

Fnc-04 ⇒ Backlight Setting

-  ⇒ To add the value flashing
-  ⇒ To reduce the value flashing
-  ⇒ To move the cursor leftward
-  ⇒ To move the cursor rightward
-  ⇒ Storage setting
-  ⇒ To abort setting or escape

CAN DIEN TU TAN HIEP THANH

2 Function Parameter Setting

Parameter Code	Function	Setting		Default Setting
		Parameter	Description	
FNC-00	Key Disable	0000	0 ON 0000 is corresponding to:	0000
		↓ 1111	1 OFF     (from left to right)	
FNC-01	DSP Update	0	No Limit	1
		1	20 times/sec.	
		2	10 times/sec.	
		3	5 times/sec.	
		4	1 times/sec.	
FNC-02	F1 Key Function Setting	0	Print (printing)	0
		1	Units (units switch)	
		2	M+ (accumulation and printing)	
		3	MC (memory clearing)	
		4	Weight/Weight Accumulation/Times Accumulation Display Switch	
		5	HR (high resolution switch)	
		6	Pre-tare (pre-tare function)	
FNC-03	F2 Key Function Setting	0	Print (printing)	1
		1	Units (units switch)	
		2	M+ (accumulation and printing)	
		3	MC (memory clearing)	
		4	Weight/Weight Accumulation/Times Accumulation Display Switch	
		5	HR (high resolution switch)	
		6	Pre-tare (pre-tare function)	
FNC-04	Backlight Setting	0	Auto Backlight On (backlight on in operation only)	0
		1	Backlight On (backlight always on)	
		2	Backlight Off	





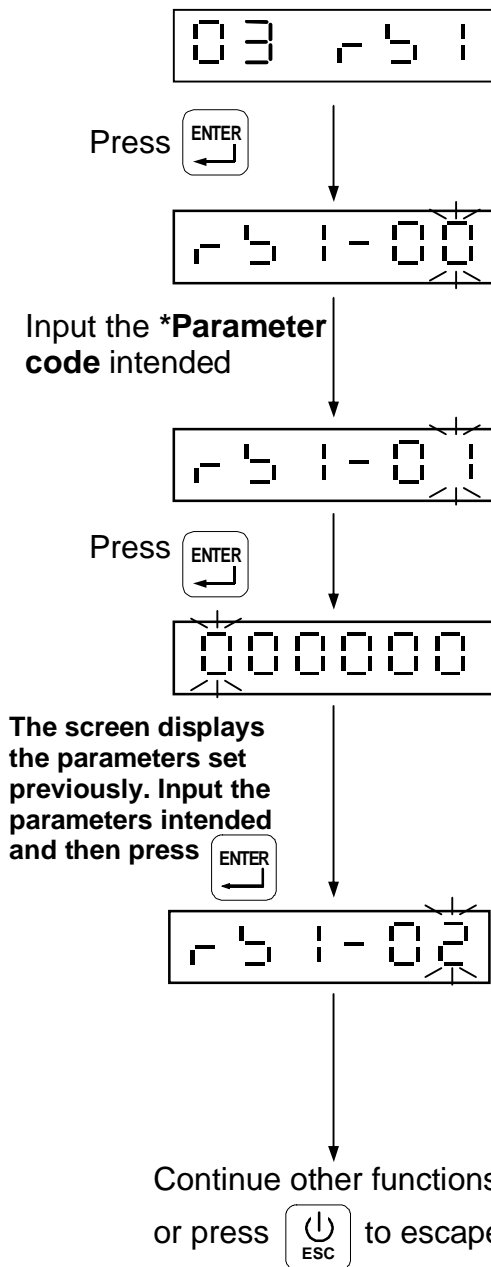

CAN DIEN TU TAN HIEP THANH

8-2 RS232 Setting 03 r 5 1



*Parameter Code

- r 5 1-00 ⇒ Information Pattern
- r 5 1-01 ⇒ Transmission Method
- r 5 1-02 ⇒ Transmission Rate
- r 5 1-03 ⇒ Parity, Bit Length, Stop Bit
- r 5 1-04 ⇒ Unstable or Over Load
- r 5 1-05 ⇒ Auto Transmission Condition
- r 5 1-06 ⇒ Command Address
- r 5 1-07 ⇒ Output Format
- r 5 1-08 ⇒ Transmission Times
- r 5 1-09 ⇒ Date Setting
- r 5 1-10 ⇒ Time Setting

-  ⇒ To add the value flashing
-  ⇒ To reduce the value flashing
-  ⇒ To move the cursor leftward
-  ⇒ To move the cursor rightward
-  ⇒ Storage setting
-  ⇒ To abort setting / escape

**CAN DIEN TU TAN HIEP THANH****2 OP-01 RS232 / RS485 Interface Function**

Parameter Code	Function	Setting		Default Setting
		Parameter	Description	
RS1-00	Information Pattern	0	Display Correspondingly	0
		1	Gross Weight	
		2	Net Weight	
		3	Tare	
		4	Weight Accumulation	
		5	Times Accumulation	
		6	Output with Date & Time	
RS1-01	Transmission Method	0	Continuous Transmission	0
		1	Auto Transmission	
		2	Press F1 or F2 ₄ to transmit	
		3	Command Mode (no address)	
		4	Command Mode (with address)	
RS1-02	Transmission Rate	0	1200	1
		1	2400	
		2	4800	
		3	9600	
		4	19200	
RS1-03	Parity Bit Length Stop Bit	0	N, 8, 1 No Parity 8 Bits Length 1 Stop Bit	2
		1	O, 7, 1 Odd Parity, 7 Bits Length, 1 Stop Bit	
		2	E, 7, 1 Even Parity, 7 Bits Length, 1 Stop Bit	
RS1-04	Unstable or Over Load	0	Continuous Output	0
		1	Stop Output	
RS1-05	Auto Transmission Condition	0	Positive (over + 10D)	0
		1	Positive/negative (over + 10D, under - 10D)	
RS1-06	Command Address	00 ↓ 99	Available only if RS1-01 setting is "4"	0
RS1-07	Output Format	0	Standard Format	0
		1	UMC 600	



CAN DIEN TU TAN HIEP THANH

RS1-08	Transmission Times	0	No Limit	4
		1	1 times/sec.	
		2	2 times/sec	
		3	5 times/sec	
		4	10 times/sec	
		5	20 times/sec	
RS1-09	Date Setting			
RS1-10	Time Setting			

CAN DIEN TU TAN HIEP THANH

2 Transmission Format

RS1-00 P 0 ~ 3



Header 1

ST : Stable Weight / US : Unstable Weight / OL : Weight Over Load

Header 2

GS : Gross Weight / NT : Net Weight / TR : Tare

Weight Data (8 digits)

The first digit of weight data represents “+/-” indication for weight value. The other 7 digits, including decimal point, represent the weight value. If the weight is over load (Header 1 : OL), the screen turns into “blank” except “+/-” indication and decimal point.

Unit

Kg, g, t, lb or “blank”

Terminators

CL and LF are data termination code.

RS1-00 = 4

T	N	,	1	2	3	CR	LF
---	---	---	---	---	---	----	----

RS1-00 = 5

T	W	,	+	1	2	3	4	.	5	6	k	g	CR	LF
---	---	---	---	---	---	---	---	---	---	---	---	---	----	----

RS1-00 = 6

D	A	T	E	:	2	0	X	X	/	X	X	/	X	X	CR	LF	
T	I	M	E	:	X	X	:	X	X	:	X	X	CR	LF			
G	R	O	S	S	:	+	1	2	3	4	.	5	6	k	g	CR	LF
N	E	T		:	+	1	2	3	4	.	5	6	k	g	CR	LF	
T	A	R	E	:	+	1	2	3	4	.	5	6	k	g	CR	LF	
T	N			:	X	X	X	CR	LF								
T	W			:	+	1	2	3	4	.	5	6	k	g	CR	LF	

CAN DIEN TU TAN HIEP THANH

2 Command Mode



Command	Function	Command	Function
READ, RW	Weight Reading	CT	Tare Clearing
ZERO, MZ	Weight Re-zeroing	RI	Weight Accumulation
TARE, MT	Gross Weight Reducing	Rm	Times Accumulation
NTGS	Gross / Net Switch	Rn	Date
MG	Gross Weight Indicating	Ro	Time
MN	Net Weight Indicating	AT	Weight and Times Accumulation
		DT	Weight and Times Accumulation Clearing

- ☒ After setting the commands mentioned above, it's necessary to add the termination code "CR(ODH) and LF(OAH)".
- If the command is not correct, it will reply "E" + "Command Unidentified".
- ☒ If setting command mode with address (RS1-06 = 4), add "@ address" in front of each command.
 Example: When RS1-08 = 1, for reading weight value, the whole complete command should be "@01RW(CR)(LF)".



CAN DIEN TU TAN HIEP THANH

<Chapter 9> Maintenance





9-1 Default Recovery for All Parameters

- (1) Adjust the calibration switch to "ON", when re-zeroing after turning on, press   and hold simultaneously.
- (2) The screen will display `In It . ALL`.
- (3) If decided, press  and hold until displaying `End`, and then adjust the calibration switch to "OFF".

9-2 Default Recovery for General Function Parameters

- (1) When re-zeroing after turning on, press   and hold simultaneously.
- (2) The screen will display `In It . Fn`.
- (3) If decided, press  and hold until re-turning on.

9-3 Self-diagnosis Mode

- (1) When re-zeroing after turning on, press  and hold.
 - (2) The screen will display `UEr`, which means entered self-diagnosis mode.
 - (3) Use  or  keys to select item intended to test.
- Press  key to enter self-diagnosis, and press  key to escape.

Item	Display	Testing Item
1	<code>UEr</code>	Program Version Number Displaying
2	<code>d5P</code>	7-segment Display Testing
3	<code>2EY</code>	Keypad and Calibration Switch Testing
4	<code>AdC</code>	AD Conversion Value Displaying
5	<code>EEP</code>	EEPROM Testing
6	<code>r tC</code>	RTC Date & Time Testing
7	<code>232</code>	OP-1 RS232 Serial Output Interface Testing

CAN DIEN TU TAN HIEP THANH

9-3-1 Program Version Number

7-segment display reveals program version number.

9-3-2 7-segment Display Testing

7-segment display reveals “0 ~ 9” and “.”.

9-3-3 Keypad & Calibration Switch Testing

Adjust calibration switch to “ON”, and press any key, the corresponding bit will be changed from \downarrow → \uparrow .

9-3-4 AD Conversion Value

7-segment display reveals the internal value of the present weight.

9-3-5 EEPROM Testing

Displaying **PASS** represents in normal condition.

Displaying **FAIL** represents in extraordinary condition.

9-3-6 RTC Time & Date Testing

Press  key to enter the testing mode, and the screen will display date XX.XX.XX.

Example: “05.11.03” represents 3rd of November, 2005.

Press  key again to display time XX.XX.XX.

Example: “09.45.50” represents 9 o'clock, 45 minute and 50 seconds.

9-3-7 RS-232 Serial Output Interface Testing (OP-01)

(1) Short the 2nd pin and 3rd pin of the SER. OUT. D-SUB 9pin socket.

Displaying **PASS** represents in normal condition.

Displaying **FAIL** represents in breakdown condition.

(2) If connected with a computer (protocol must be corresponding), the screen will display 0 ~ 9, which means RS-232 output is in normal condition.