

Models:

- A5WM 07G/GR□
- A5WM 09G/GR□
- A5WM 10G/GR□
- A5WM 15G/GR□
- A5WM 20G/GR□
- A5WM 25G/GR□
- A5WM 301/1R□

ACSON[®]
International



Wall Mounted Split Systems

1. NOMENCLATURE

Indoor

Others
A : First issue
Grille Type
B : Grille B
Air Treatment Devices & Control
I : Negative Ion with wireless controller N : NTP with wireless controller X : Oxygen unit
Market Region
C : Export with CE mark U : UTL Spec.
Electrical
A : 220 - 240V/1Ph/50Hz

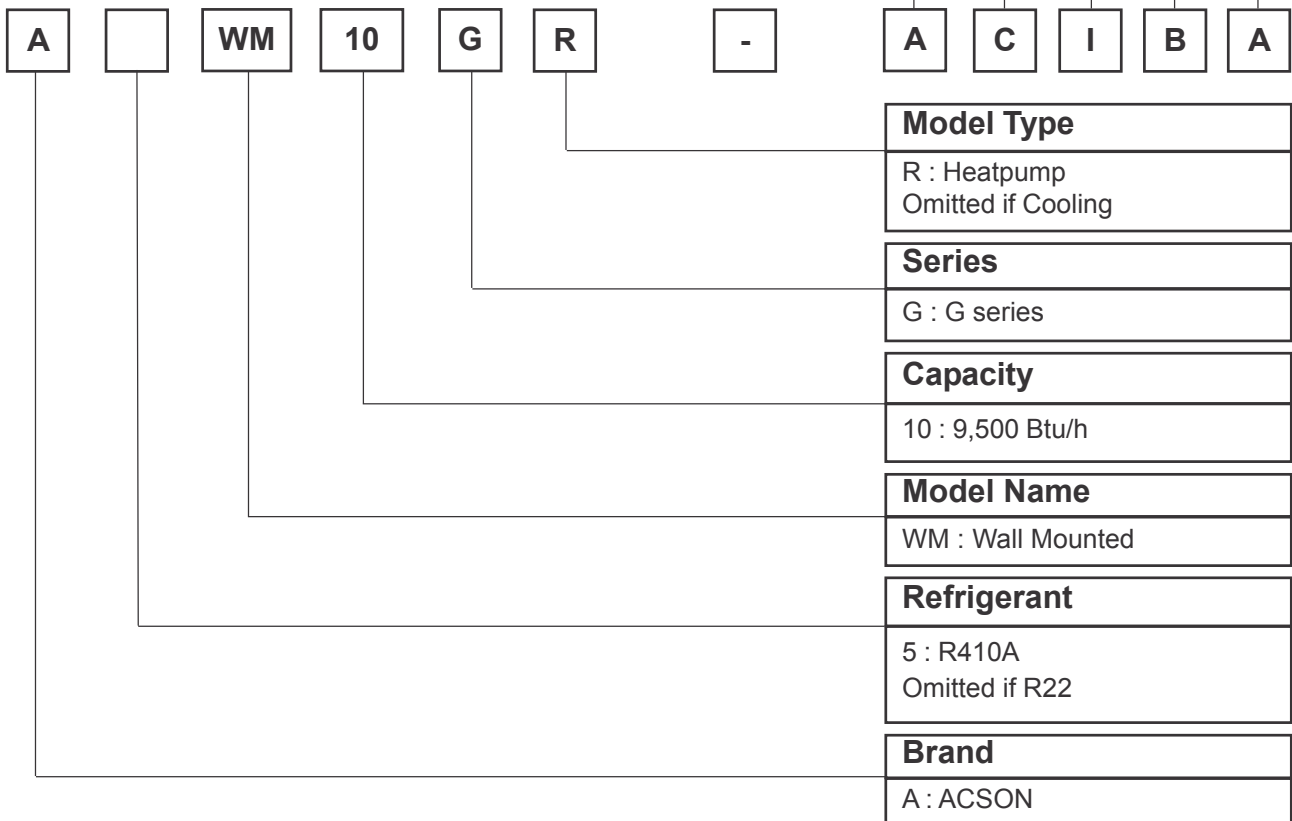

Outdoor

Others	
A : First issue	
Specification Variation	
O : Standard Unit B : With Contactor G : Low Ambient Kit H : High Ambient Kit	I : Gold Fins L : Long Piping Unit S : With H/L Pressure Switch X : Oxygen Unit
Compressor	
P : Matsushita Rotary M : Mitsubishi Rotary	T : Toshiba Rotary S : Samsung Rotary
Market Region	
C : Export with CE marking E : Export without marking U : ETL Spec.	
Electrical	
A : 220 - 240V/1Ph/50Hz	

A 5 LC 10 C R - A C P O A

Model Type
R : Heatpump Omitted if Cooling Only
Series
C : C series
Capacity
10 : 9,500 Btu/h
Model Name
LC : Single Split Condensing Unit
Refrigerant
5 : R410A Omitted if R22 Model
Brand
A : ACSON

Outdoor

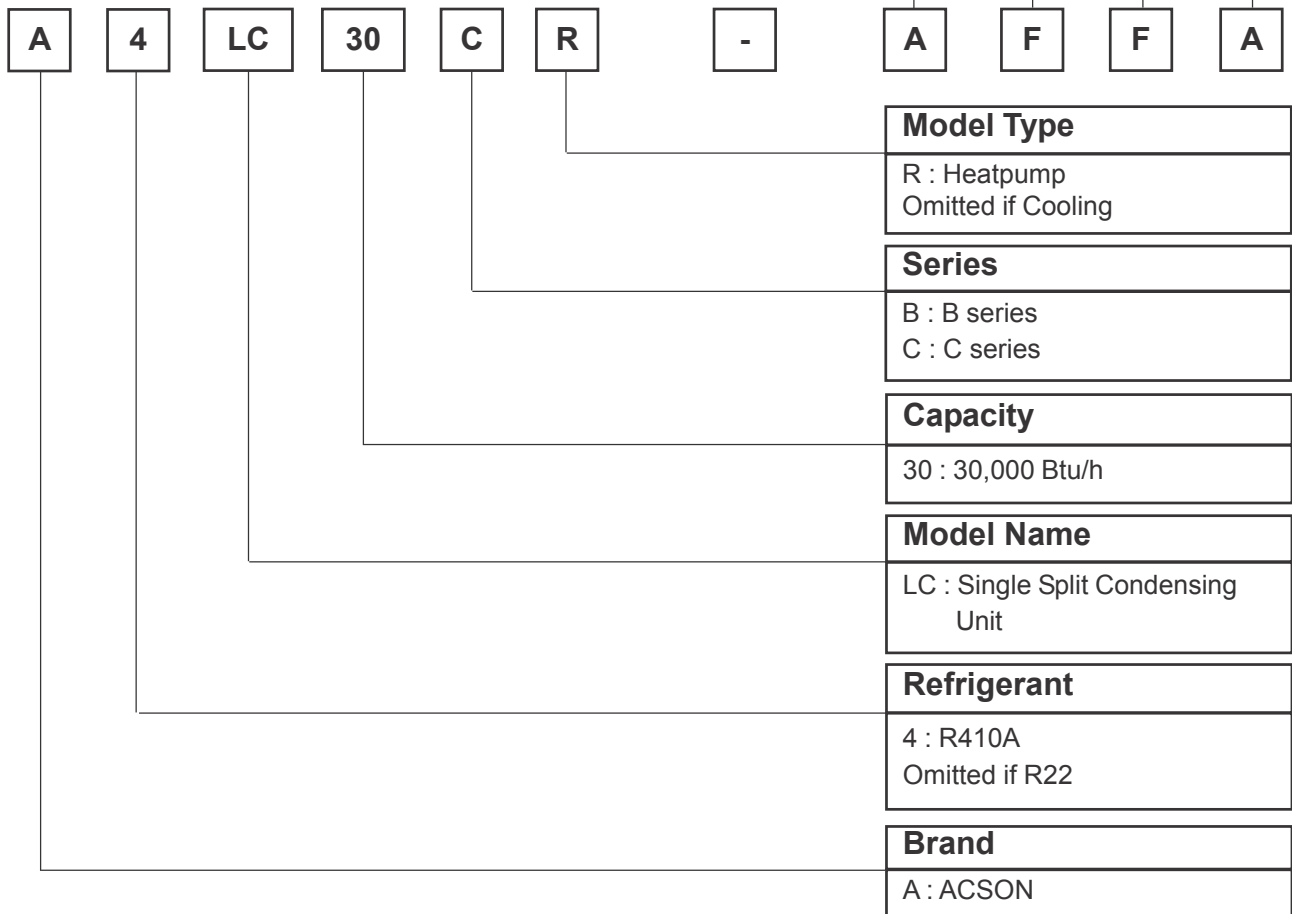
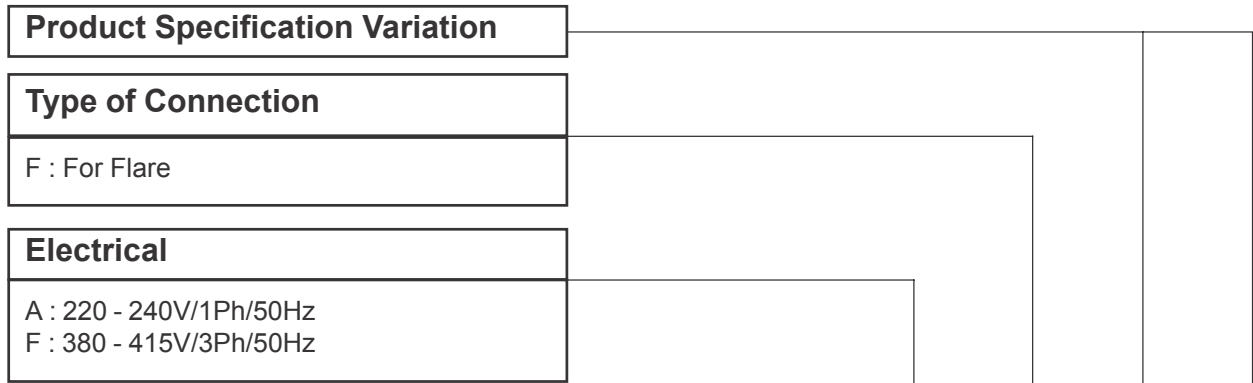

2. FEATURES

€ **EASY INSTALLATION**

- The wall mounted fan coil unit is easily installed because of its compact size, slimness and light weight.
- Slim and short outdoor unit can be easily installed even in a narrow balcony and passageway and yet have a stable profile.

€ **SPACE SAVING**

- No space is required on either floor or ceiling. This newly developed super slim design for wall mounting maximizes floor space usage and enhances ceiling appearance where ceilings are low.

€ **QUIET OPERATION**

- Cooling comfort is improved by whisper-quiet operation which is achieved by a tangential fan.

€ **EXCELLENT AIR DISTRIBUTION**

- Air discharge direction can be adjusted in four directions, manually or automatically by using LCD remote control.
- The new double louver design with automatic air swing function fully optimizes the room comfort by distributing the air evenly to the room.
- The unique skew fan design with larger diameter creates better air flow to the operating environment.

€ **FACILITATED MAINTENANCE ENSURED**

- The new design of air discharge housing whereby the fan blower can be easily accessed by just loosing two screws on the unit to provides a flexible, faster and easier way to clean up the fan blower and ionizer.
- Maintenance is easy for electrical components, piping and wiring as these are all easily accessible by merely removing front plastic panel.

€ **WIRELESS REMOTE CONTROL**

- The compact LCD transmitter is able to operate the air conditioner unit within the distance of 9 meters.
- Fan motor speed can be set at low/medium/high or automatic.
- Sleep mode auto control will gradually increase or decrease the setting temperature to provide a comfortable surrounding for sleeping.
- Air flow direction can be controlled automatically.
- Room temperature is controlled by electronic thermostat.
- The real time timer allows the air conditioner to be switched On and Off automatically based on user settings.
- Turbo mode function is available to enables the required set temperature to be achieved in a short time.
- Ionizer or non-thermal plasma is available to create better air quality.
- Personalized Setting allows user to preset and store 2 groups of personal settings (including timer setting) in the handset.
- Auto random restart is a function whereby when there is power failure occurred during operation, the unit will automatically restart as the last setting condition once the power is resumed.

€ **MOISTURE REMOVAL**

- Dry mode with super low indoor fan speed can achieve more affective moisture removal.
- If the room temperature is lower than the set temperature (Cooling mode only), the compressor will cut out and force on after 9 minutes to remove moisture effectively.

€ HIGH EFFICIENCY HEAT EXCHANGER

- The compact design of the 3-fold structure heat exchanger provides a large surface area for better and efficient heat exchange.
- The unique Hydrophilic slit fin has greatly improved the air flow and the contact surfaces with the air thus to boost the cooling capacity.

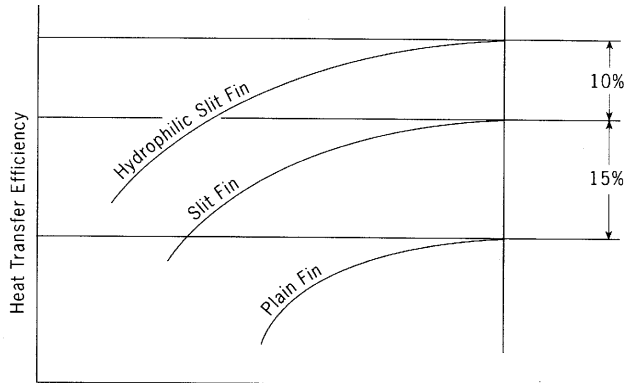

€ ROTARY COMPRESSOR

- The ever popular rotary compressor is more energy efficient and has a higher output to weight ratio.

€ SELF DIAGNOSIS

- This function is able to detect and to diagnose any faults occurring in the system by blinking of the LED lights.
- Simplify and ease for troubleshooting.

**INDOOR UNIT
A5WM-G SERIES PRODUCT LINE UP**

A5WM		Nomenclature	CLASSIFICATIONS												
			Handset		PCB			Air Purification					Marking	Grille	
			G12	G12 (W/O Turbo mode)	L2.0	D2.0	U1.5	Ionizer Filter	Saranet Filter	Negative Ion	Nano Technology Air Filtration	O ₂ Therapy	Non-Thermal Plasma (NTP)	CE	B
Cooling Model	07G	ACIBC	X		X					X	X			X	X
		ACNBC	X		X						X		X	X	X
	09G	ACIBC	X		X					X	X			X	X
		ACNBC	X		X						X		X	X	X
	10G	ACIBC	X		X					X	X			X	X
		ACNBC	X		X						X		X	X	X
		ACXBC	X		X					X	X	X		X	X
	15G	ACIBC	X		X					X	X			X	X
		ACNBC	X		X						X		X	X	X
		ACXBC	X		X					X	X	X		X	X
	20G	ACIBC	X		X					X	X			X	X
		ACNBC	X		X						X		X	X	X
	25G	ACIBC	X		X					X	X			X	X
ACNBC		X		X						X		X	X	X	
311	AFCA		X		X		X	X					X		
Heatpump Model	07GR	ACIBC	X		X					X	X			X	X
		ACNBC	X		X						X		X	X	X
	09GR	ACIBC	X		X					X	X			X	X
		ACNBC	X		X						X		X	X	X
	10GR	ACIBC	X		X					X	X			X	X
		ACNBC	X		X						X		X	X	X
	15GR	ACIBC	X		X					X	X			X	X
		ACNBC	X		X						X		X	X	X
	20GR	ACIBC	X		X					X	X			X	X
		ACNBC	X		X						X		X	X	X
	25GR	ACIBC	X		X					X	X			X	X
		ACNBC	X		X						X		X	X	X
	301R	AFCA		X			X	X	X					X	

**OUTDOOR UNIT
A5LC PRODUCT LINE UP**

A5LC		Nomenclature	CLASSIFICATIONS									
			Refrigerant Ctrl + Fin		Safety Devices			Special	Grille	Compressor	Marking	Others
			Cap. Tube	Gold Fin	Contacto	HP	LP	O ₂ Therapy	Back Panel Grille	Mat. Rotary	CE Marking	Drain Elbow
Cooling Model	07C	ACPOE	X							X	X	
	10C	ACPOB	X							X	X	
		ACPXB	X				X			X	X	
	15C	ACPOA	X							X	X	
		ACPXA	X				X			X	X	
	20C	ACPOC	X							X	X	
	25C	ACPOC	X							X	X	
28C	ACPOA	X							X	X		
Heat Pump Model	07CR	ACPOE	X							X	X	X
	10CR	ACPOB	X							X	X	X
	15CR	ACPOA	X							X	X	X
	20CR	ACPOC	X							X	X	X
	25CR	ACPOC	X							X	X	X
	28CR	ACPOA	X							X	X	X

11. CONTROLLER

G12 REMOTE CONTROLLER

Temperature Setting

- € To set the desired room temperature, press the button to increase or decrease the set temperature.
- € The temperature setting range is from 16°C to 30°C
- € Press both buttons simultaneously to toggle the temperature setting between °C and °F

On/Off Button

- € Press Once to start the air conditioner
- € Press again to stop the unit

ON Timer Setting

- € Press the SET button will activate the on timer function.
- € Set the desired on time by pressing the SET button continuously.
- € Press the CLR button to cancel the off timer setting

Fan Speed Selection

- € Press the button until the desired fan speed is achieved.

Turbo Mode

- € Press the TURBO button to achieve the required set temperature in a short time.

Automatic Air Awing

- € Press the SWING button to activate the automatic air swing function.
- € To distribute the air to a specific direction, press the SWING button and wait until the louver move to the desired direction and press the button once again.

Ionizer

- € Press the button to activate the negative Ion function, which will refresh the indoor air effectively.

Personalised Setting

- € Press and hold the button for 3s to initiate personalized setting.
- € Set the individual setting e.g. MODE, SET TEMP or FAN SPEED and leave for 4s to save
- € 2 groups of settings are allowed to stored in the handset

OFF Timer Setting

- € Press the SET button will activate the off timer function.
- € Set the desired off time by pressing the SET button continuously.
- € Press the CLR button to cancel the off timer setting

Clock Time Setting

- € Press button + or - to increase or decrease the clock time.

Sleep Mode

- € Press the button to activate sleep mode. This function is available under COOL, HEAT & AUTO mode.
- € When it is activated in COOL mode, the set temperature will be increased 0.5°C after 30mins, 1°C after 1 hour and 2°C after 2 hours.
- € When it is activated in HEAT mode, the set temperature will be decreased 1°C after 30mins, 2°C after 1 hour and 3°C after 2 hours.

Operating Mode

- € Press the MODE button to select the type of operating mode.
- € For Cooling only unit, the available modes are: COOL, DRY & FAN.
- € For Heatpump unit, the available modes are: AUTO, COOL, DRY, FAN & HEAT.

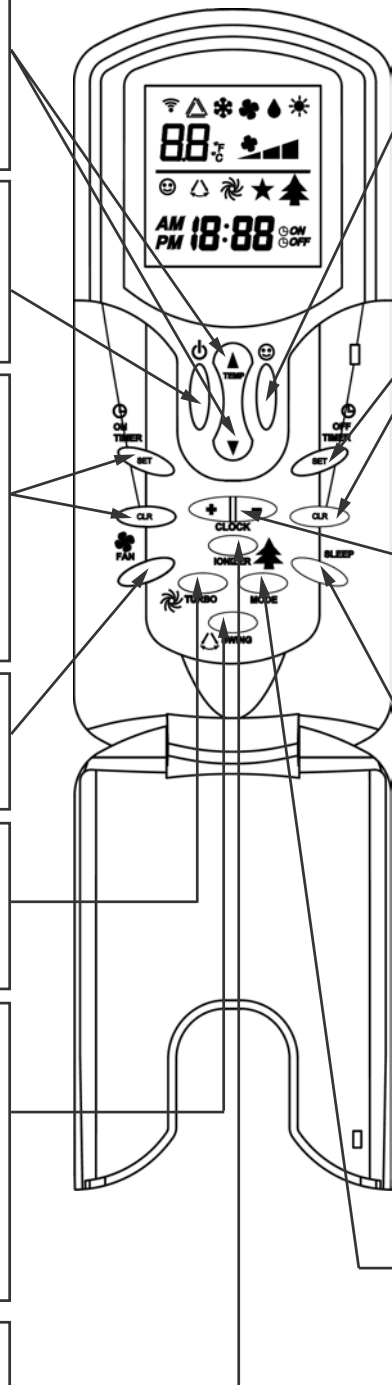

INDICATOR LIGHTS

AWM / A5WM - G SERIES

IR signal receiver

When there is infrared remote control operating signal, the signal receiver on indoor unit will make a (beep) for signal acceptance confirmation.

Cooling unit / Heatpump unit

The table below shows the LED indicator light for air conditioner unit under normal operation and fault condition. The LED indicator lights are located at the middle of the air conditioner unit.



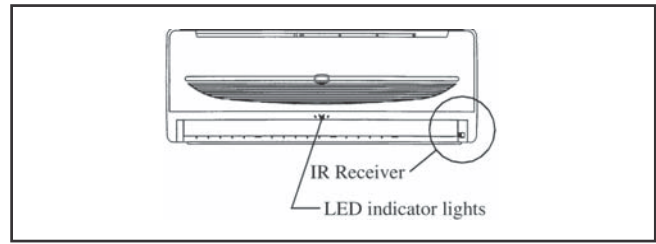

The heat pump units is equipped with an "auto" mode, whereby the unit will provide reasonable room temperature by switching the unit automatically to either "cool" mode or "heat" mode, according to the temperature setting set by the user.

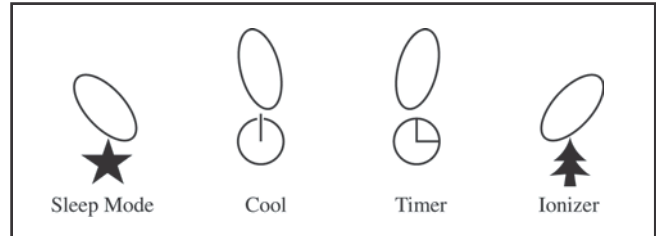

LED Indicator Lights for Cooling Unit / Heatpump Unit



LED Indicator Lights : Normal Operation And Faulty Indication Table

	 COOL/HEAT (GREEN/RED)			Normal Operation / Fault Indication	Action
○/●	○ Green		○/●	Cool mode	-
○/●	○ Red		○/●	Heat mode	-
○/●	○ Red		○/●	Auto mode in Heating operation	-
○/●	○ Green		○/●	Auto mode in Cooling operation	-
	○	○		Timer on	-
○	○			Sleep mode on	-
	○		○	Ionizer on	-
	○		○/●	Fan mode on	-
	○		○/●	Dry mode on	-
	● 1 time			Room air sensor contact Loose / Short	Call your dealer
	● 3 times			Outdoor coil sensor open	Call your dealer
●	●			Indoor coil sensor open	Call your dealer
		● 1 time		Compressor overload / Indoor coil sensor short / Outdoor coil sensor short	Call your dealer
	● Red			Defrost operation	-
		● 3 times		Gas leak	Call your dealer
		● 5 times		Outdoor coil sensor exist (MS mode)	Call your dealer
		● 6 times		Hardware error (tact switch pin short)	Call your dealer

○ - ON

○/● - ON or OFF

● - Blinking



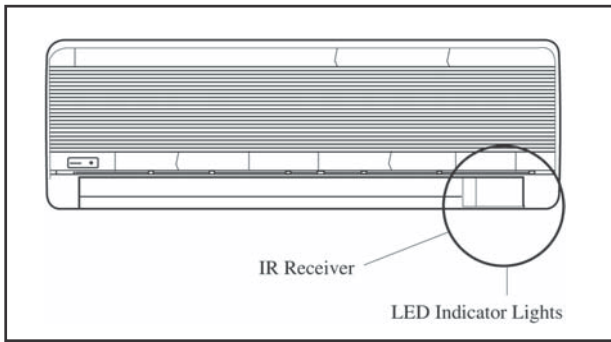



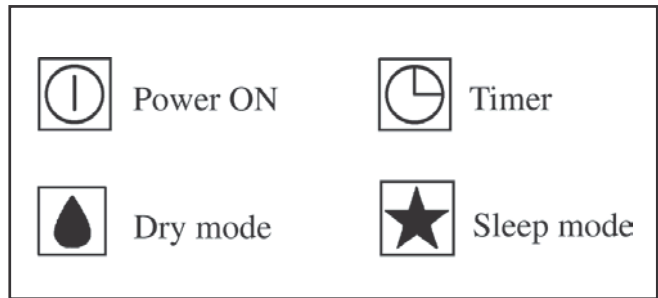

AWM 301 / 301R , A5WM 311 / 301R



LED Indicator Lights For Cooling Unit



LED Indicator Lights : Normal Operation And Fault Conditions For Cooling Unit

 Power	 Dry	 Timer	 Sleep	Operation / Fault Indication	Action
○		○		Timer on	-
○			○	Sleep mode on	-
○	○			Dry mode on	-
 Continuously	○/●			Frost prevention	Clean the filter and switch to high fan
 once every 2 sec.				Room air sensor contact loose / short	Call your dealer
 twice every 2 sec.				Indoor coil sensor contact loose / short	Call your dealer
 3 times every 2 sec.				Sensor contact problem, compressor overload protection trip or gas leak	Call your dealer

○ - ON



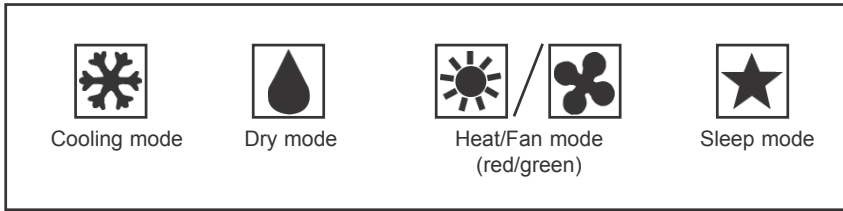

○/● - ON or OFF

◐ - Blinking

LED Indicator Lights For Heatpump Unit



LED Indicator Lights : Normal Operation And Fault Conditions For Cooling Unit

 Cool	 Dry	 Fan	 Heat	 Sleep	Normal Operation / Fault Indication	Action
○				○/●	Cooling mode	-
	○				Dry mode	-
		○			Fan mode	-
			○	○/●	Heat mode	-
◐			○	○/●	Auto mode in heating operation	-
○			◐	○/●	Auto mode in cooling operation	-
			◐		Defrost operation	-
◐					Compressor overload protection	Call your dealer
				◐	Indoor coil sensor contact loose/short	Call your dealer
	◐				Outdoor coil sensor contact loose/short	Call your dealer
		◐			Room air sensor contact loose/short	Call your dealer
◐	◐				If the system is in cool mode or heat mode (with the sleep function off), the sensor may have a contact problem, compressor overload protection trip or gas leak.	

○ - ON

○/● - ON or OFF

◐ - Blinking

CONTROLLER SPECIFICATIONS

(A) 3 HOT SYSTEM (HEATING CYCLE)

a) Hot start

At the beginning of heating operation (cold start, after defrosting or thermostat resumes operation) the indoor fan operation is controlled in accordance with the temperature of the indoor heat exchanger to send warm air from the start.

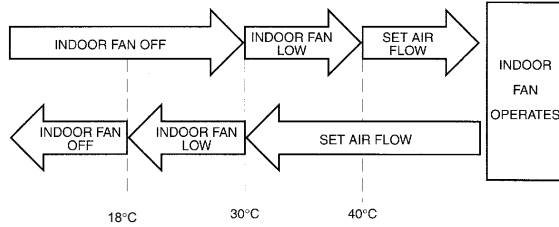

b) Hot keep (Apply to AWM301R)

After thermostat cut out, the indoor fan operation is controlled in accordance with the indoor heat exchanger temperature to utilize the extra heat and preserve indoor comfort.

The indoor fan can be switched to ON, OFF, INTERVAL by setting the slide switch shown in the diagram. This slide switch is located at the front frame cover.

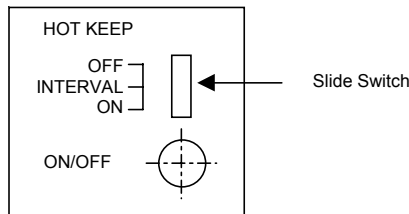

Note 1 : Fan ON (default)

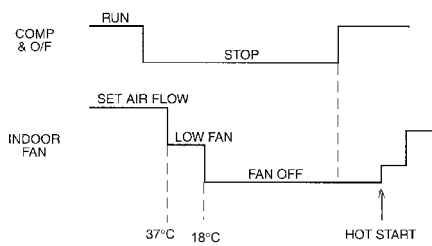

Note 2: Fan OFF

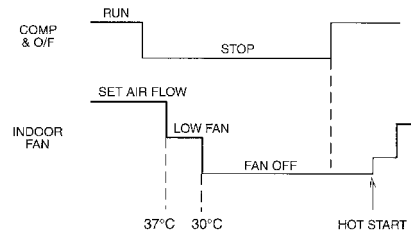

Note 3 : Interval

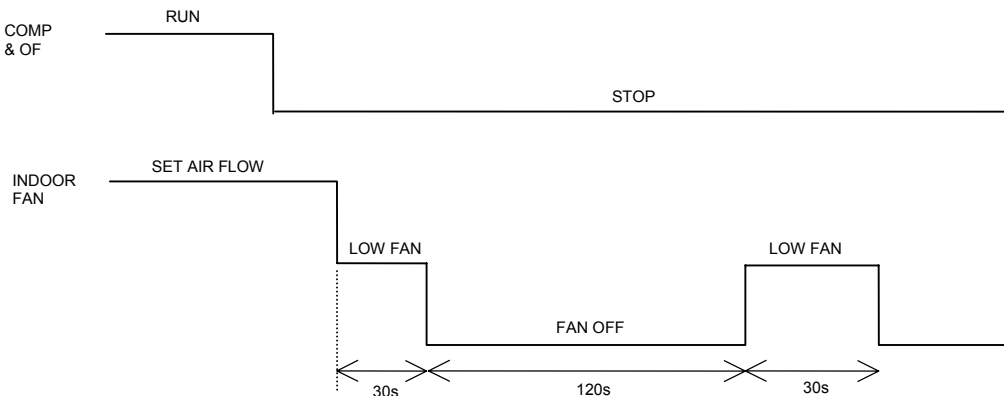

Hot Keep (Apply to AWM-GR)

After thermostat cut out, the indoor fan operation is controlled in accordance with the indoor heat exchanger temperature to utilize the extra heat and preserve indoor comfort.

The indoor fan can be switched to ON, OFF by setting the slide switch shown in the diagram. This slide switch is located at the front frame cover.

Multisplit Model Selection

The indoor unit can be changed to multisplit model by just selecting MS through the slide switch.

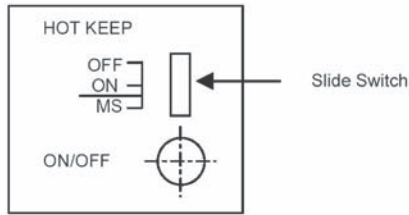

Note 1 : Fan ON (default)

Note 2: Fan OFF

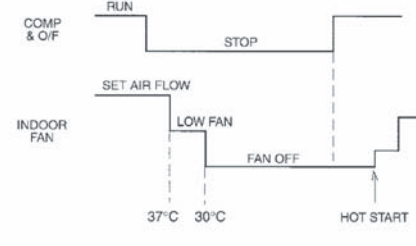
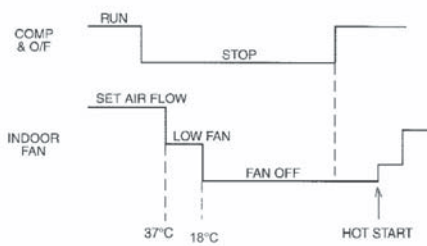

c) Hot spurt

During cold start, the set temperature of controller is increased by 2°C to stabilize the room temperature quickly.

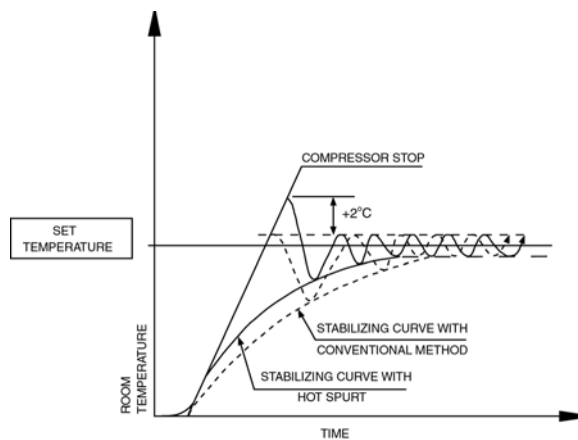

(B) TURBO MODE (APPLY TO AWM-GR)

TURBO function is available in COOL, HEAT and DRY modes only. When TURBO function is set, working temperature for cooling cycle is decreased by 2°C, working temperature for heating cycle is increased by 2°C. The indoor fan will force to HIGH fan. After 20 minutes, this function will clear automatically, no more offset temperature for set temperature and indoor fan will restore. Cold start will be overridden when TURBO function is activated. If TURBO and SLEEP are activated at the same time, the SLEEP mode timer will be reset, it will resume after TURBO function is cleared.

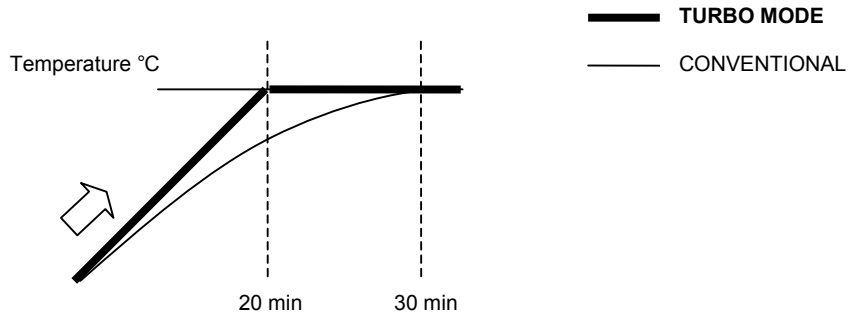

(C) OVERLOAD PREVENTION IN HEATING OPERATION

During heating operation, if the room temperature and outdoor temperature are high, or when the indoor air filter is choked, the condensing pressure will increase rapidly. To prevent the burn out of compressor, the M. C. controller will stop the operation of the air conditioner under this condition.

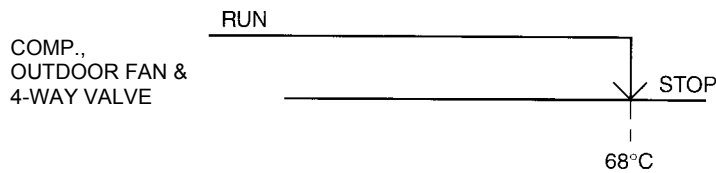

∉ For manual reset type, the ON / OFF button must be pressed to reset the system.

(D) OVERLOAD PROTECTION IN COOLING OPERATION

When outdoor and indoor air temperature raise beyond the operation limit, or when the outdoor coil choked with dirt, the M.C. controller detects abnormal increase in condensing temperature. It will stop the operation to prevent compressor burn out.

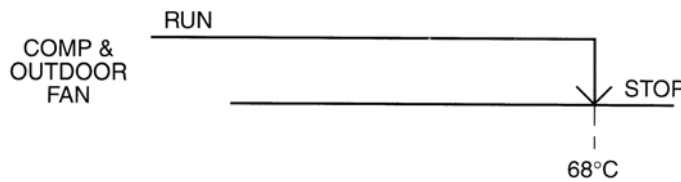

(E) FROST PREVENTION AND FILTER CHECK

In order to prevent the freezing of indoor coil, the controller will operate as follow.

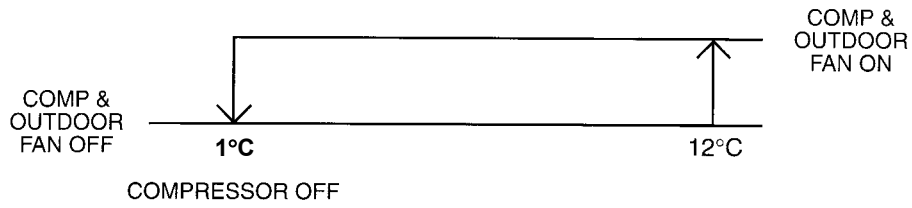

(F) AUTO RANDOM RESTART

When power resumed, the unit will automatically restart and operate at the previous setting as before power failure occurred.

13. SERVICING AND MAINTENANCE

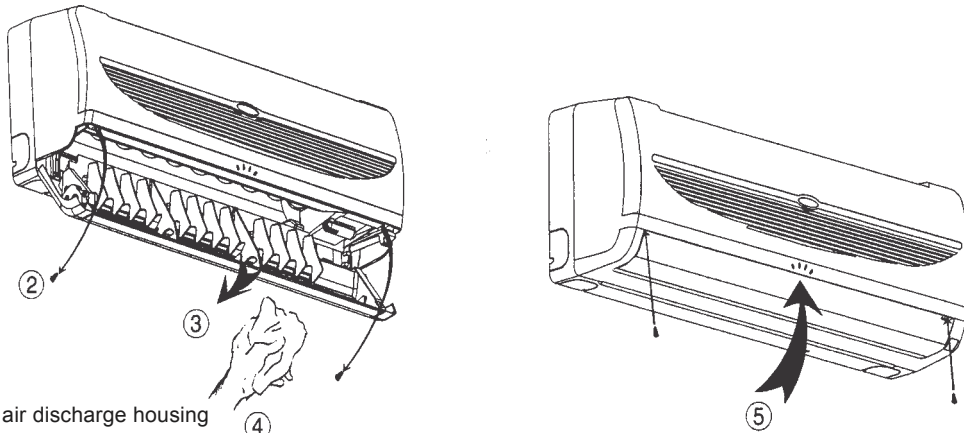

- ① Off the unit
- ② Unscrew the air discharge housing
- ③ Flip open the air discharge housing
- ④ Clean the blower
- ⑤ Close the air discharge housing and tighten it with screw

The unit is designed to give a long life operation with minimum maintenance required. However, it should be regularly checked and the following items should be given due attention.

Components	Maintenance Procedure	Recommended Schedule
Indoor Air Filter	<ol style="list-style-type: none"> 1. Remove any dust adhering on the filter by using a vacuum cleaner or wash in lukewarm water (below 40°C/104°F) with a neutral cleaning detergent. 2. Rinse the filter well and dry before placing it back onto the unit. 3. Do not use gasoline, volatile substances or chemicals to clean the filter. 	At least once every 2 weeks. More frequently if necessary.
Indoor Unit	<ol style="list-style-type: none"> 1. Clean any dirt or dust on the grille or panel by wiping it with a soft cloth soaked in lukewarm water (below 40°C/104°F) and a neutral detergent solution. 2. Do not use gasoline, volatile substances or chemicals to clean the indoor unit. 	At least once every 2 weeks. More frequently if necessary.
Condensate Drain Pan and Pipe	<ol style="list-style-type: none"> 1. Check and clean. 	Every 3 months.
Indoor Fan	<ol style="list-style-type: none"> 1. Check for unusual noise. 	As necessary.
Indoor/Outdoor Coil	<ol style="list-style-type: none"> 1. Check and remove dirt which are clogged between fins. 2. Check and remove obstacles which hinder air flow in and out of indoor/outdoor unit. 	Every month. Every month.
Electrical	<ol style="list-style-type: none"> 1. Check voltage, current and wiring. 2. Check faulty contacts caused by loose connections, foreign matters, etc. 	Every 2 months. Every 2 months.
Compressor	<ol style="list-style-type: none"> 1. No maintenance needed if refrigerant circuit remains sealed. However, check for refrigerant leak at joints and fittings. 	Every 6 months.
Compressor Lubrication	<ol style="list-style-type: none"> 1. Oil is factory charged. Not necessary to add oil if circuit remains sealed. 	No maintenance required.
Fan Motors Lubrication	<ol style="list-style-type: none"> 1. All motors pre-lubricated and sealed at factory. 	No maintenance required.

14. TROUBLESHOOTING

When a malfunction of the air conditioner unit is detected, immediately switch off the main power supply before proceeding with the following troubleshooting procedures.

The following are common fault conditions and simple troubleshooting tips. If any other fault conditions which are not listed occur, contact your nearest local dealer. DO NOT attempt to troubleshoot the unit by yourself.

No	Fault conditions	Possible causes / corrective actions
1	The air conditioner unit will not resume after power failure.	<ul style="list-style-type: none"> • The auto restart function is not functioning. Please turn on the unit with the wireless / wired controller.
2	The compressor does not operate 3 minutes after the air conditioner unit is started.	<ul style="list-style-type: none"> • Protection against frequent starting. • Wait for 3 or 4 minutes for the compressor to start operating by it self.
3	The airflow is too slow or room cannot be cooled sufficiently.	<ul style="list-style-type: none"> • The air filter is dirty. • The doors and windows are opened. • The air suction and discharge of both indoor and outdoor units are clogged or blocked. • The regulated temperature or temperature setting is not low enough.
4	Discharge airflow has bad odor.	<ul style="list-style-type: none"> • Cigarettes, smoke particles, perfume and others, which might have adhered onto the coil, may cause odor. • Contact your nearest dealer.
5	Condensation on the front air grille of the indoor unit.	<ul style="list-style-type: none"> • This is caused by air humidity after an extended period of operation. • The set temperature is too low. Increase the temperature setting and operate the unit at high fan speed.
6	Water flowing out from the air conditioner.	<ul style="list-style-type: none"> • Switch off the unit and contact your nearest dealer. This might be due to tilted installation.
7	Hissing airflow sound from the air conditioner unit during operation.	<ul style="list-style-type: none"> • Liquid refrigerant flowing into the evaporator coil.
8	The wireless controller display is dim.	<ul style="list-style-type: none"> • The batteries are discharged. • The batteries are not correctly inserted. • The assembly is not good.
9	Compressor operates continuously.	<ul style="list-style-type: none"> • Dirty air filter. Clean the air filter. • Temperature setting too low (cooling). Use higher temperature setting. • Temperature setting too high (heating), Use lower temperature setting.
10	No cool air comes out during cooling cycle, or no hot air comes out during heating cycle.	<ul style="list-style-type: none"> • Temperature setting too high (cooling). Use lower temperature setting. • Temperature setting too low (heating). Use higher temperature setting.
11	On heating cycle, warm air does not come out.	<ul style="list-style-type: none"> • Unit is in defrost mode. Heating operation will resume after defrost cycle ends.

15. EXPLODED VIEW AND PARTS LIST

INDOOR UNIT

MODEL: A5WM / AWM 07G / 07GR / 09G / 09GR / 10G / 10GR / 15G / 15GR

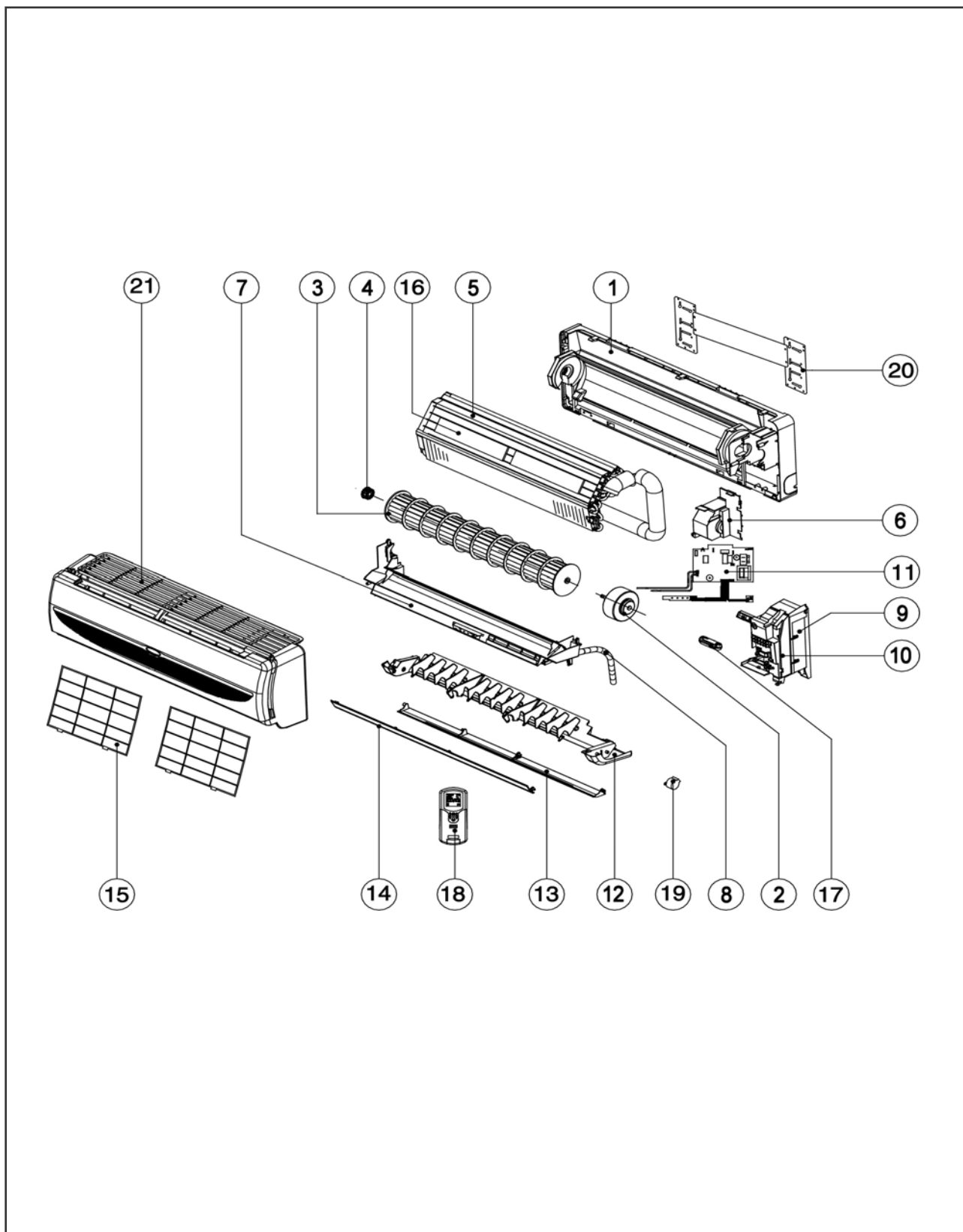

A5WM / AWM 07G / 09G / 10G / 15G

No	Descriptions	Part No
1	Assy., Chassis	
	A5WM / AWM 07/09G	A50124064147
	A5WM / AWM 10/15G	A50124064151
2	Fan, Motor	
	A5WM / AWM 07/09G	A03034064425
	A5WM / AWM 10/15G	A03034064426
3	Cross Flow Fan	
	A5WM / AWM 07/09G	A03029019462
	A5WM / AWM 10/15G	A03029019461
4	Fan, Bush	A11014029514
5	Assy., Coil	
	A5WM / AWM 07/09G	A50024063765
	A5WM / AWM 10/15G	A50024064225
6	Piping, Clamp	A12014060544
7	Assy., Drain Pan	
	A5WM / AWM 07/09G	A50124064148
	A5WM / AWM 10/15G	A50124064152
8	Drain Hose	A10024018204
9	Assy., Control Box	A12014060545
10	Assy., Control Box Cover	A50124064666
11	L2 Control Module	
	A5WM / AWM 07/09G	A04084064633
	A5WM / AWM 10/15G	A04084064634

No	Descriptions	Part No
12	Air Discharge Housing	
	A5WM / AWM 07/09G	A50124062325
	A5WM / AWM 10/15G	A50124062326
13	Lower Louver	
	A5WM / AWM 07/09G	A12014060538
	A5WM / AWM 10/15G	A12014061364
14	Upper Louver	
	A5WM / AWM 07/09G	A12014060537
	A5WM / AWM 10/15G	A12014061363
15	Saranet Air Filter	
	A5WM / AWM 07/09G	A12014062320
	A5WM / AWM 10/15G	A12014062321
16	Titanium Oxide Filter	A03089015250
	Anti-Microbial Filter	A03089019984
17	Assy., Negative Ionizer	A04239019730
18	G12 handset	A04084065327
19	Air Swing Motor	A03039004235
20	Assy, Mounting Plate	
	A5WM / AWM 07/09G	A50014061333
	A5WM / AWM 10/15G	A50014062324
21	Assy., Front Cover	
	A5WM / AWM 07/09G	A50124064664
	A5WM / AWM 10/15G	A50124064675

A5WM / AWM 07GR / 09GR / 10GR / 15GR

No	Descriptions	Part No
1	Assy., Chassis	
	A5WM / AWM 07/09GR	A50124064147
	A5WM / AWM 10/15GR	A50124064151
2	Fan, Motor	
	A5WM / AWM 07/09GR	A03034064425
	A5WM / AWM 10/15GR	A03034064426
3	Cross Flow Fan	
	A5WM / AWM 07/09GR	A03029019462
	A5WM / AWM 10/15GR	A03029019461
4	Fan, Bush	A11014029514
5	Assy., Coil	
	A5WM / AWM 07/09GR	A50024063765
	A5WM / AWM 10GR	A50024064225
	A5WM / AWM 15GR	A50024066054
6	Piping, Clamp	A12014060544
7	Assy., Drain Pan	
	A5WM / AWM 07/09GR	A50124064148
	A5WM / AWM 10/15GR	A50124064152
8	Drain Hose	A10024018204
9	Assy., Control Box	A12014060545
10	Assy., Control Box Cover	A50124064667
11	L2 Control Module	A04084067263

No	Descriptions	Part No
12	Air Discharge Housing	
	A5WM / AWM 07/09GR	A50124062325
	A5WM / AWM 10/15GR	A50124062326
13	Lower Louver	
	A5WM / AWM 07/09GR	A12014060538
	A5WM / AWM 10/15GR	A12014061364
14	Upper Louver	
	A5WM / AWM 07/09GR	A12014060537
	A5WM / AWM 10/15GR	A12014061363
15	Saranet Air Filter	
	A5WM / AWM 07/09GR	A12014062320
	A5WM / AWM 10/15GR	A12014062321
16	Titanium Oxide Filter	A03089015250
	Anti-Microbial Filter	A03089019984
17	Assy., Negative Ionizer	A04239019730
18	G12 handset	A04084067315
19	Air Swing Motor	A03039004235
20	Assy, Mounting Plate	
	A5WM / AWM 07/09GR	A50014061333
	A5WM / AWM 10/15GR	A50014062324
21	Assy., Front Cover	
	A5WM / AWM 07/09GR	A50124064664
	A5WM / AWM 10/15GR	A50124064675

MODEL: A5WM / AWM 20G / 20GR / 25G / 25GR

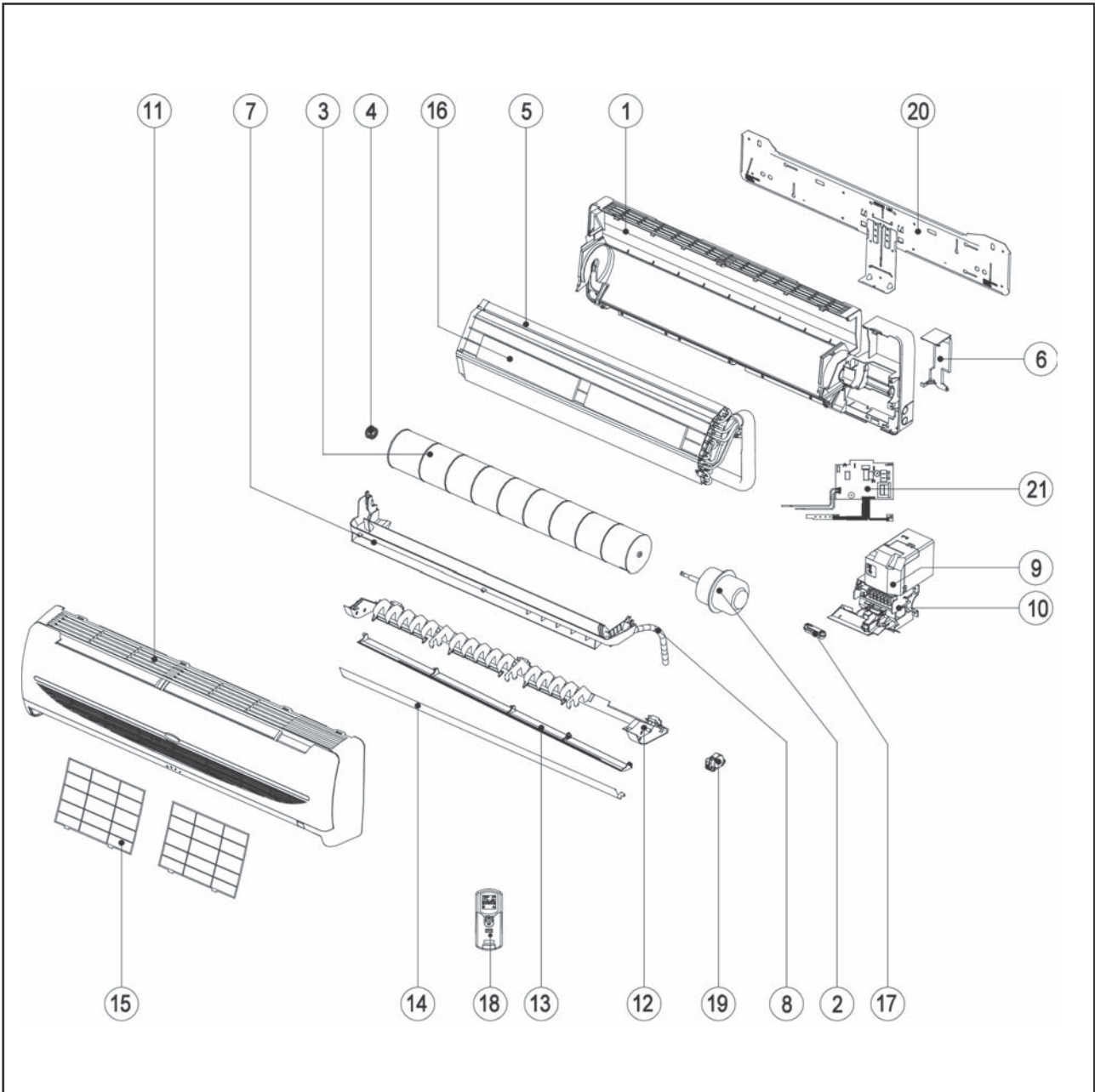

MODEL : A5WM / AWM 20G / 25G

No	Descriptions	Part No
1	Assy., Chassis	A50124068170
2	Fan, Motor	
	AWM 20G	A03034074205
	AWM 25G	A03034074204
3	Cross Flow Fan	A03019007388
4	Fan, Bush	A11014023775
5	Assy., Coil	
	AWM 20G	A50024072203
	AWM 25G	A50024072204
	A5WM 20G	A50024074031
	A5WM 25G	A50024074032
6	Piping, Clamp	A12014071297
7	Assy., Drain Pan	A50124068171
8	Drain Hose	A10024015319

No	Descriptions	Part No
9	Assy., Control Box	A50044071955
10	Assy., Control Box Cover	A50124071418
11	Assy., Front Cover	A50124071425
12	Air Discharge Housing	A50124071426
13	Lower Louver	A12014066821
14	Upper Louver	A12014066820
15	Saranet Air Filter	A12014066832
16	Titanium Oxide Filter	A03089015250
	Anti-Microbial Filter	A03089019984
17	Assy., Negative Ionizer	A04239022932
18	G12 handset	A04084065327
19	Air Swing Motor	A03039022933
20	Assy, Mounting Plate	A50014036133
21	L2 Control Module	A04084071971

MODEL : A5WM / AWM 20GR / 25GR

No	Descriptions	Part No
1	Assy., Chassis	A50124068170
2	Fan, Motor	
	AWM 20GR	A03034074205
	AWM 25GR	A03034074204
3	Cross Flow Fan	A03019007388
4	Fan, Bush	A11014023775
5	Assy., Coil	
	AWM 20GR	A50024072203
	AWM 25GR	A50024072204
	A5WM 20GR	A50024074031
	A5WM 25GR	A50024074032
6	Piping, Clamp	A12014071297
7	Assy., Drain Pan	A50124068171
8	Drain Hose	A10024015319

No	Descriptions	Part No
9	Assy., Control Box	A50044071960
10	Assy., Control Box Cover	A50124071419
11	Assy., Front Cover	A50124071425
12	Air Discharge Housing	A50124071426
13	Lower Louver	A12014066821
14	Upper Louver	A12014066820
15	Saranet Air Filter	A12014066832
16	Titanium Oxide Filter	A03089015250
	Anti-Microbial Filter	A03089019984
17	Assy., Negative Ionizer	A04239022932
18	G12 handset	A04084067315
19	Air Swing Motor	A03039022933
20	Assy, Mounting Plate	A50014036133
21	L2 Control Module	A04084071973

MODEL: AWM 301 / 301R, A5WM 311 / 301R

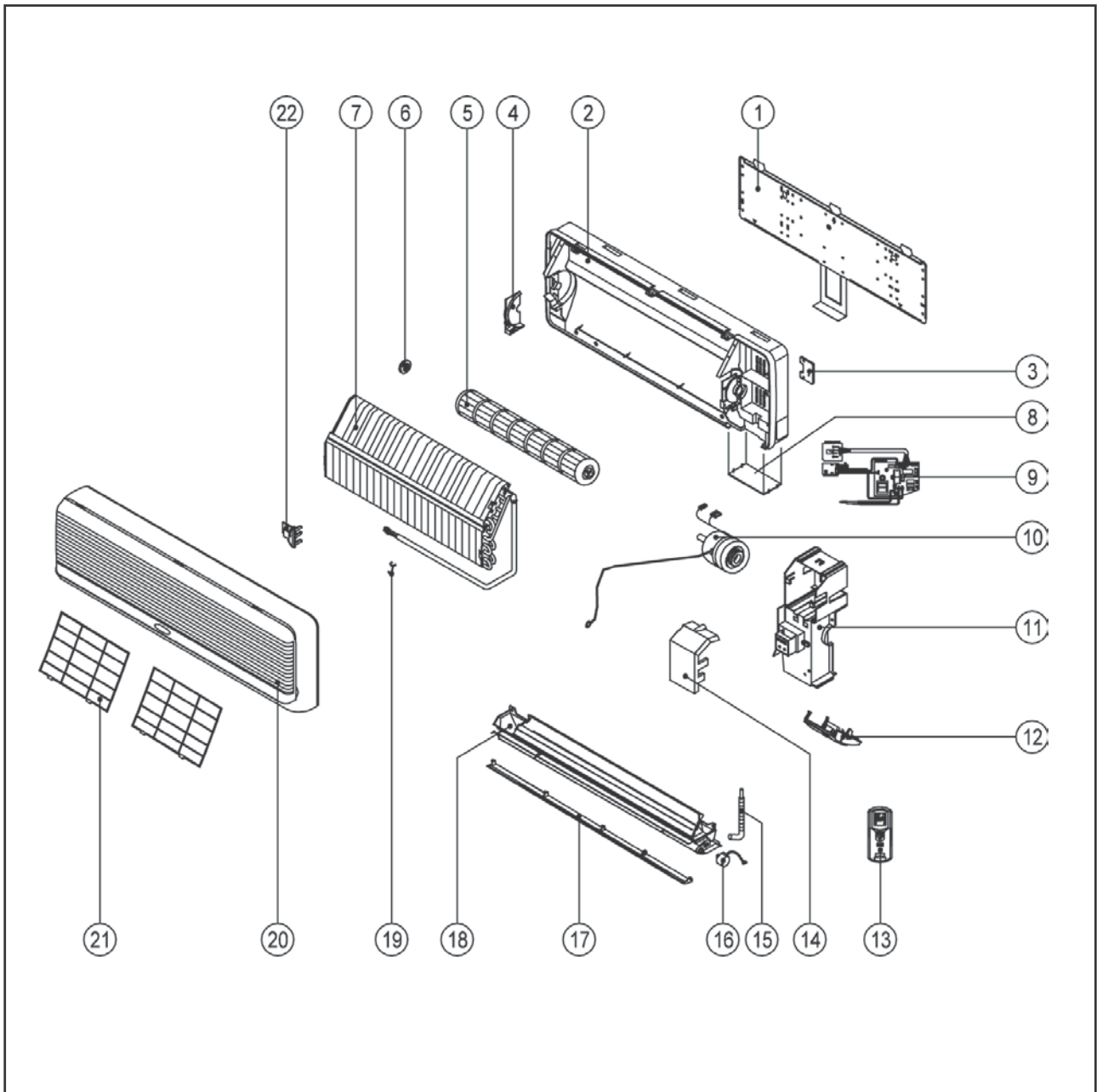

MODEL : A5WM 311 / AWM 301

No	Description	Part No
1	ASSY, INSTALLATION BRACKET	A50014050721
2	ASSY. CHASSIS	A50124050703
3	PIPING CLAMP	A07014024546
4	FAN BUSH BRACKET	A12014050709
5	CROSS FLOW FAN	A03029013842
6	FAN BUSH	A11019013841
7	ASSY., INDOOR COIL	
	AWM301	A50024050710
	A5WM311	A50024084359
8	SERVICE PANEL	A12014050685
9	CONTROL MODULE	A04084051409
10	FAN MOTOR	A03034052105

No	Description	Part No
11	ASSY, CONTROL BOX	A50044052607
12	LED LIGHT BRACKET	A12014050679
13	G12 HANDSET	A04084065328
14	CONTROL BOX COVER	A12014050681
15	ASSY. DRAIN HOSE	A10024015319
16	AIR SWING MOTOR	A03039007088
17	AIR LOUVER	A12014050717
18	ASSY. AIR DISCHARGE HOUSING	A50124050712
19	COIL SENSOR CLIP	A07054021183
20	ASSY. FRONT COVER	A50124050723
21	SARANET FILTER	A12014050726
22	THERMISTOR HOLDER	A12014016707

MODEL : A5WM 301R / AWM 301R

No	Description	Part No
1	ASSY, INSTALLATION BRACKET	A50014050721
2	ASSY. CHASSIS	A50124050703
3	PIPING CLAMP	A07014024546
4	FAN BUSH BRACKET	A12014050709
5	CROSS FLOW FAN	A03029013842
6	FAN BUSH	A11019013841
7	ASSY., INDOOR COIL	
	AWM301R	A50024050710
	A5WM301R	A50024084359
8	SERVICE PANEL	A12014050685
9	U1.5 CONTROL MODULE	A04084052604
10	FAN MOTOR	A03034052105

No	Description	Part No
11	ASSY, CONTROL BOX	A50044052607
12	LED LIGHT BRACKET	A12014050679
13	G12 HANDSET	A04084073477
14	CONTROL BOX COVER	A12014050681
15	ASSY. DRAIN HOSE	A10024015319
16	AIR SWING MOTOR	A03039007088
17	AIR LOUVER	A12014050717
18	ASSY. AIR DISCHARGE HOUSING	A50124050712
19	COIL SENSOR CLIP	A07054021183
20	ASSY. FRONT COVER	A50124050723
21	SARANET FILTER	A12014050726
22	THERMISTOR HOLDER	A12014016707

**OUTDOOR UNIT
MODEL: A5LC 07C**

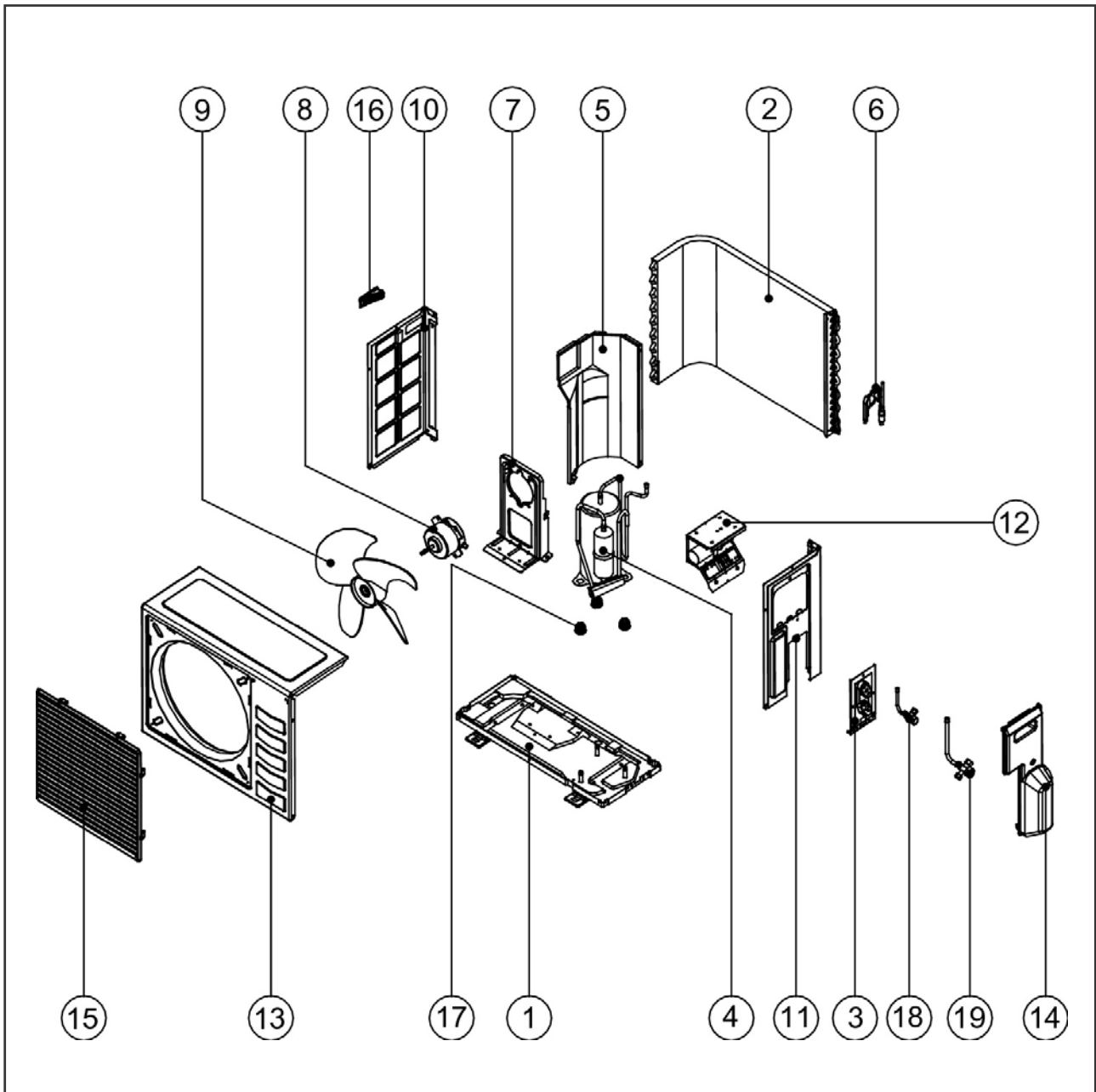

No	Descriptions	Part No
1	Assy., Base Pan	A50014057372
2	Assy., Condenser Coil	A50024064720
3	Valve Bracket	A01014051164
4	Compressor	A04019019592
5	Assy., Partition	A50064065275
6	Assy., Cap Tube	A50024064527
7	Bracket, Fan Motor	A01014052516
8	Fan Motor	A03039015324
9	Fan Blade	A03019004131

No	Descriptions	Part No
10	Left Panel	A01014052510
11	Right Panel	A01014052509
12	Assy. Control Panel	A50044054806
13	Assy., Front Panel	A01014052512
14	Assy., Valve Cover	A50124055172
15	Assy., Front Grille	A50124056905
16	Plastic, Handle	A12014057948
17	Rubber Grommet	A11059011558
18	Assy., Flare Valve 2 Ways 1/4"	A50059019453
19	Assy., Flare Valve 3 Ways 3/8"	A50059019454

MODEL: A5LC 10C / 15C

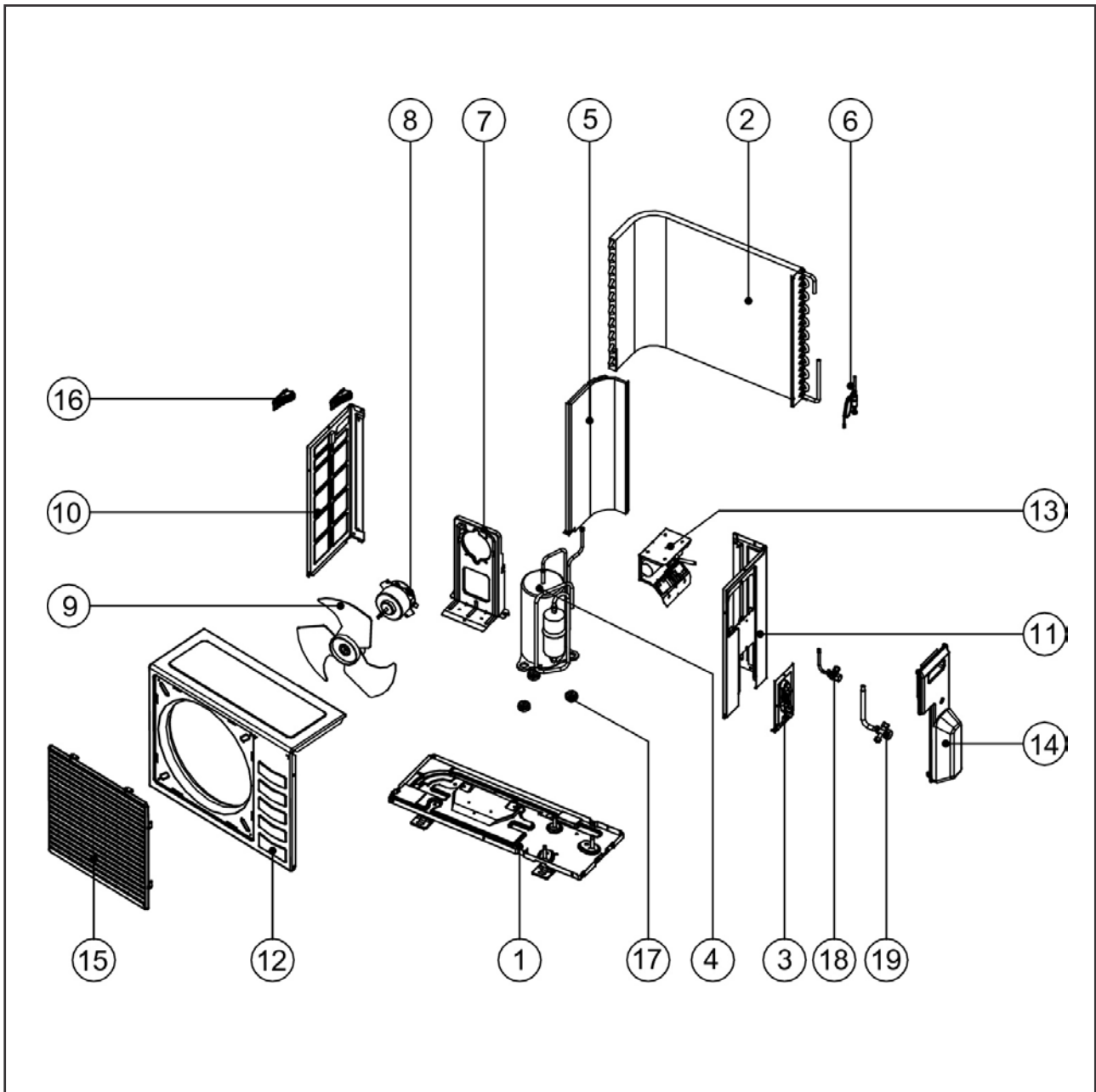

No	Descriptions	Part No
1	Assy., Base Pan	A50014051158
2	Assy., Condenser Coil	A50024064721
3	Valve Bracket	A01014051164
4	Compressor	
	A5LC 10C	A04019019590
	A5LC 15C	A04019019594
5	Assy., Partition	A50064055063
6	Assy., Cap Tube	
	A5LC 10C	A50024056101
	A5LC 15C	A50024054807
7	Bracket, Fan Motor	A01014051162
8	Fan Motor	
	A5LC 10C	A03039016104
	A5LC 15C	A03039015323
9	Fan Blade	A03019015339
10	Left Panel	A01014051166

No	Descriptions	Part No
11	Right Panel	A01014051167
12	Assy., Front Panel	A01014051171
13	Assy. Control Panel	
	A5LC 10C	A50044058195
	A5LC 15C	A50044057994
14	Assy., Valve Cover	A50124051173
15	Assy., Front Grille	A50124056700
16	Plastic, Handle	A12014057948
17	Rubber Grommet	
	A5LC 10C	A11054000272
	A5LC 15C	A11054000271
18	Assy., Flare Valve 2 Ways 1/4"	A50059019453
19	Assy., Flare Valve 3 Ways 3/8"	
	A5LC 10C	A50059019454
	Assy., Flare Valve 3 Ways 1/2"	
	A5LC 15C	A50054019452

MODEL: A5LC 07CR

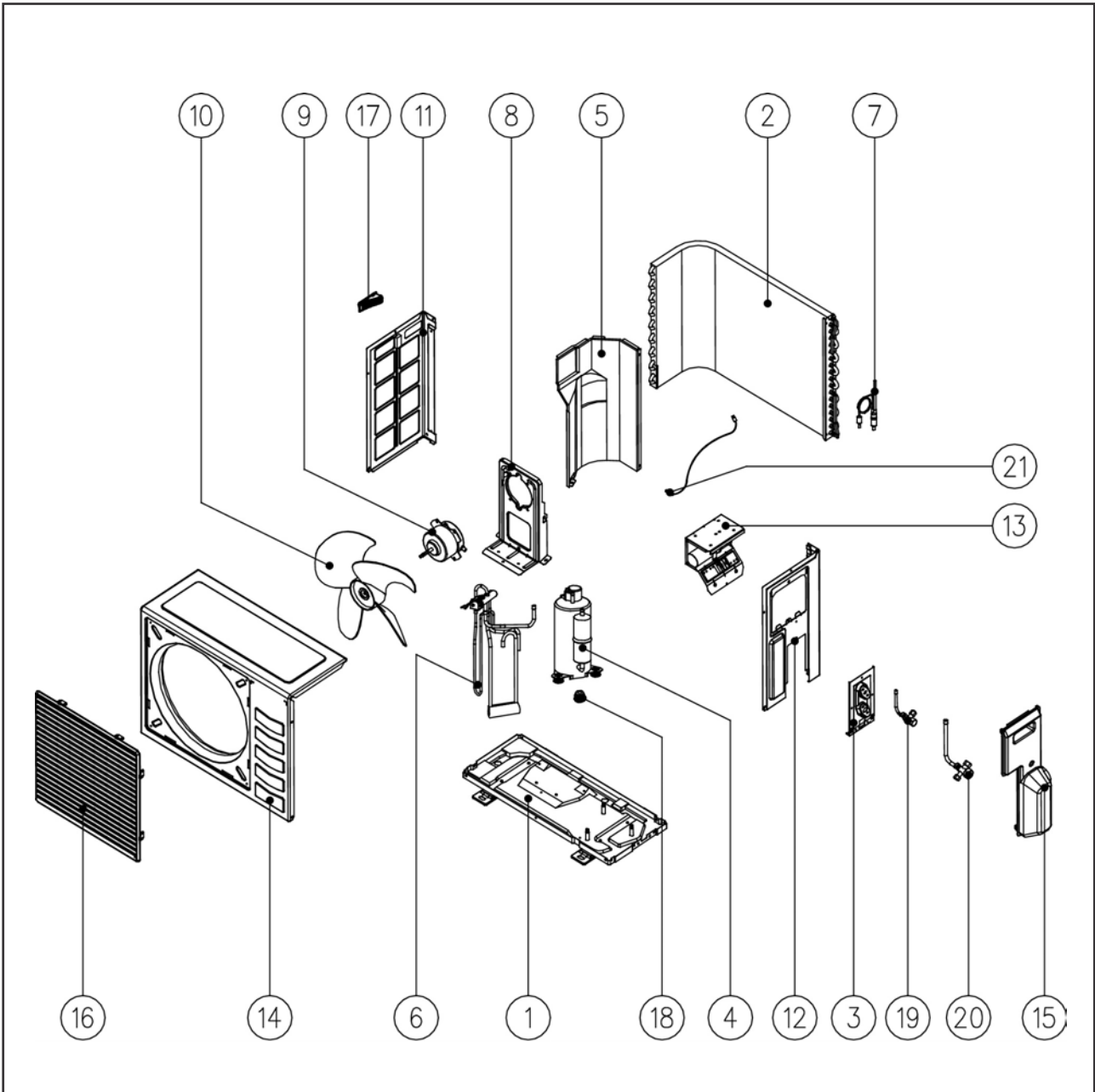

No.	Descriptions	Part No
1	Assy., Base Pan	A50014057372
2	Assy., Condenser Coil	A50024064720
3	Valve Bracket	A01014051164
4	Compressor	A04019019592
5	Assy., Partition	A50064065275
6	Assy., 4 Way Valve	A50024066259
7	Assy., Cap Tube	A50024066452
8	Bracket, Fan Motor	A01014052516
9	Fan Motor	A03039015324
10	Fan Blade	A03019004131
11	Left Panel	A01014052510

No.	Descriptions	Part No
12	Right Panel	A01014052509
13	Assy. Control Panel	A50044059032
14	Assy., Front Panel	A01014052512
15	Assy., Valve Cover	A50124055172
16	Assy., Front Grille	A50124056905
17	Plastic, Handle	A12014057948
18	Rubber Grommet	A11059011558
19	Assy., Flare Valve 2 Ways 1/4"	A50059019453
20	Assy., Flare Valve 3 Ways 3/8"	A50059019454
21	Sensor, Outdoor Defrost	A50134039416

MODEL: A5LC 10CR / 15CR

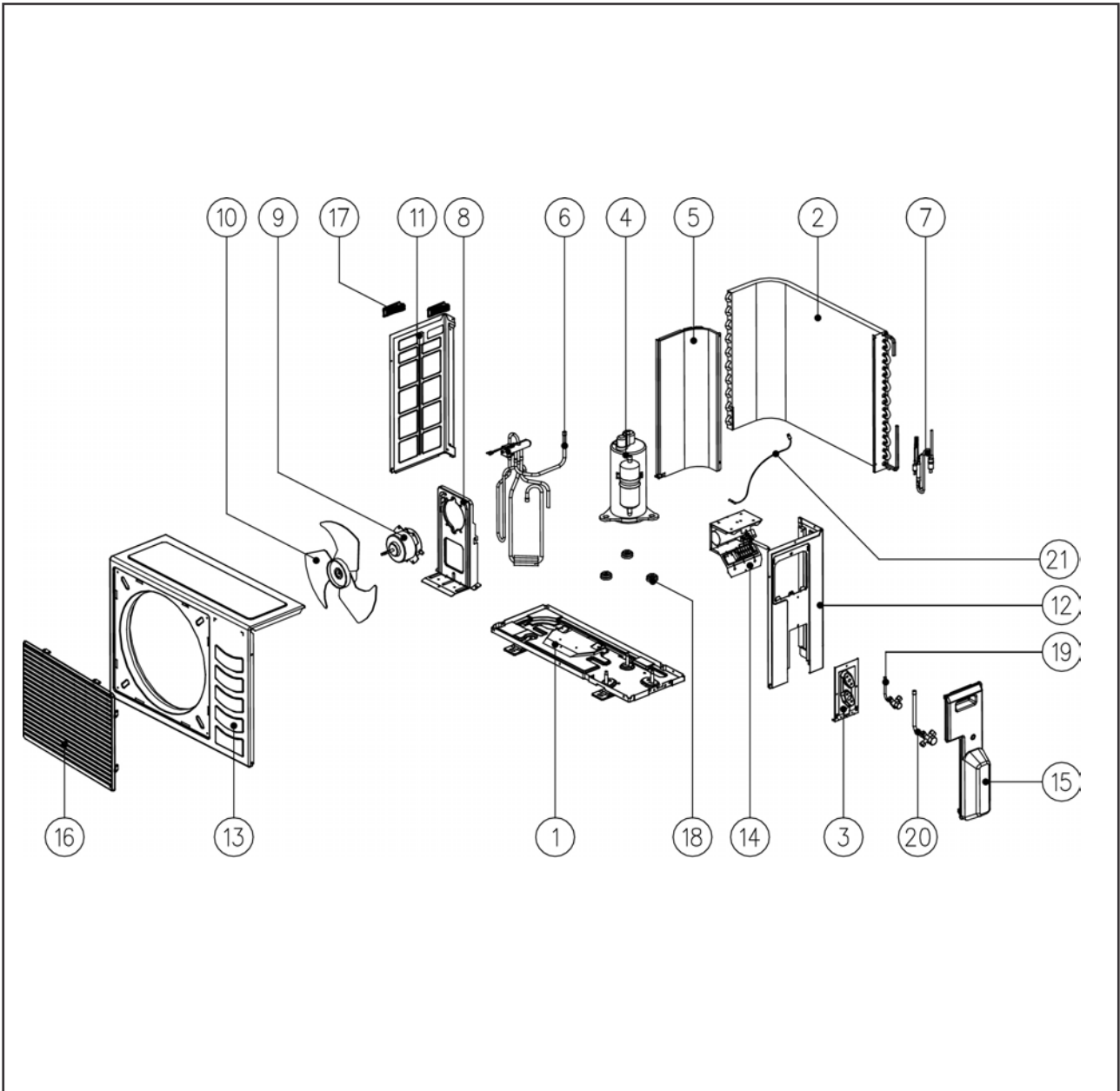

No.	Descriptions	Part No
1	Assy., Base Pan	A50014051158
2	Assy., Condenser Coil	
	A5LC 10CR	A50024064721
	A5LC 15CR	A50024066517
3	Valve Bracket	A01014051164
4	Compressor	
	A5LC 10CR	A04019019590
	A5LC 15CR	A04019019594
5	Assy., Partition	A01014051165
6	Assy., 4 Way Valve	A50024066173
7	Assy., Cap Tube	
	A5LC 10CR	A50024066256
	A5LC 15CR	A50024066493
8	Bracket, Fan Motor	A01014051162
9	Fan Motor	
	A5LC 10CR	A03039016104
	A5LC 15CR	A03039015323
10	Fan Blade	A03019015339

No.	Descriptions	Part No
11	Left Panel	A01014051166
12	Right Panel	A01014051167
13	Assy., Front Panel	A01014051171
14	Assy. Control Panel	
	A5LC 10CR	A50044059033
	A5LC 15CR	A50044059034
15	Assy., Valve Cover	A50124051173
16	Assy., Front Grille	A50124056700
17	Plastic, Handle	A12014057948
18	Rubber Grommet	
	A5LC 10CR	A11054000272
	A5LC 15CR	A11054000271
19	Assy., Flare Valve 2 Ways 1/4"	A50059019453
20	Assy., Flare Valve 3 Ways 3/8"	
	A5LC 10CR	A50059019454
	Assy., Flare Valve 3 Ways 1/2"	
	A5LC 15CR	A50054019452
21	Sensor, Outdoor Defrost	A50134039416

MODEL: ALC 18C, A5LC / ALC 20C

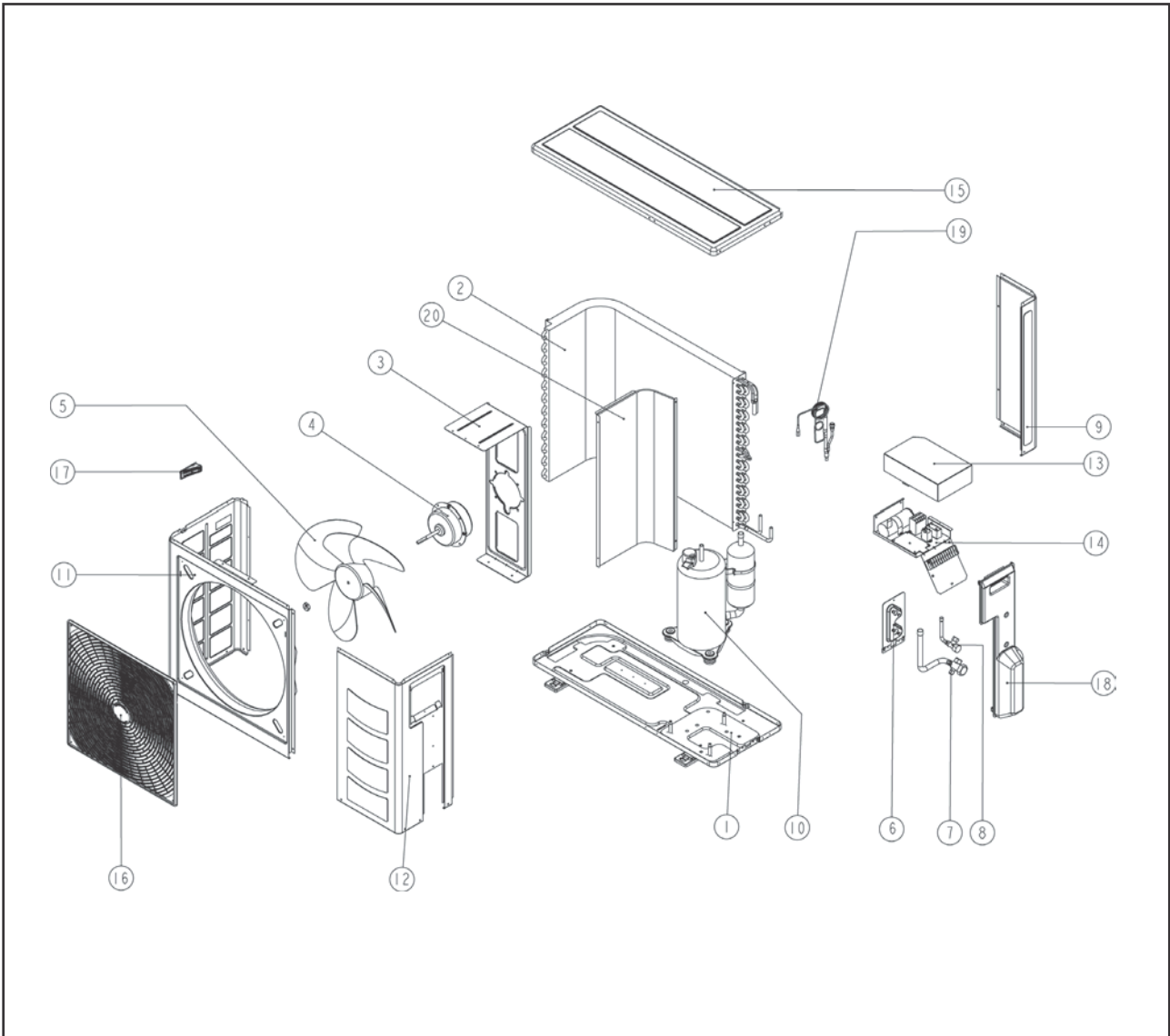

No.	Descriptions	Part No
1	Assy. Base Pan	
	ALC 18C	A50014077978
	A5LC/ALC 20C	A50014013884
2	Assy. Outdoor Coil	
	ALC 18C	A50024077968
	ALC 20C	A50024070651
	A5LC 20C	A50024079078
3	Motor Bracket	A01014070601
4	Fan Motor	
	ALC 18C	A03039024539
	A5LC/ALC 20C	A03039023391
5	Fan Blade	A03019023393
6	Valve Bracket	A50014072861
7	Assy. Flare Valve 3 Ways 5/8"	
	ALC 18C/20C	A50054072863
	Assy. Flare Valve 3 Ways 1/2"	
	A5LC 20C	A50059023335
8	Assy. Flare Valve 2 Ways 1/4"	
	ALC 18C/20C	A50059022156
9	Assy. Flare Valve 2 Ways 1/4"	
	A5LC 20C	A50059023334
	Back Panel, Right	A01014070599

No.	Descriptions	Part No
10	Compressor	
	ALC 18C	A50049022614
	ALC 20C	A04019018334
	A5LC 20C	A04019021361
11	Front Panel, Left	A01014070597
12	Service Panel	A01014070598
13	Terminal Cover Panel	A01014070838
14	Assy. Control Panel	
	ALC 18C	A50044077990
	ALC 20C	A50044073902
	A5LC 20C	A50044072876
15	Top Panel	A01014070596
16	Assy. Front Grille	A50124072880
17	Plastic Handle	A12014057948
18	Assy. Valve Cover	A50124072885
19	Assy. Cap Tube	
	ALC 18C	A50024077976
	ALC 20C	A50024077257
	A5LC 20C	A50024079156
20	Partition	A01014070603

MODEL: A5LC / ALC 25C, A5LC / ALC 28C

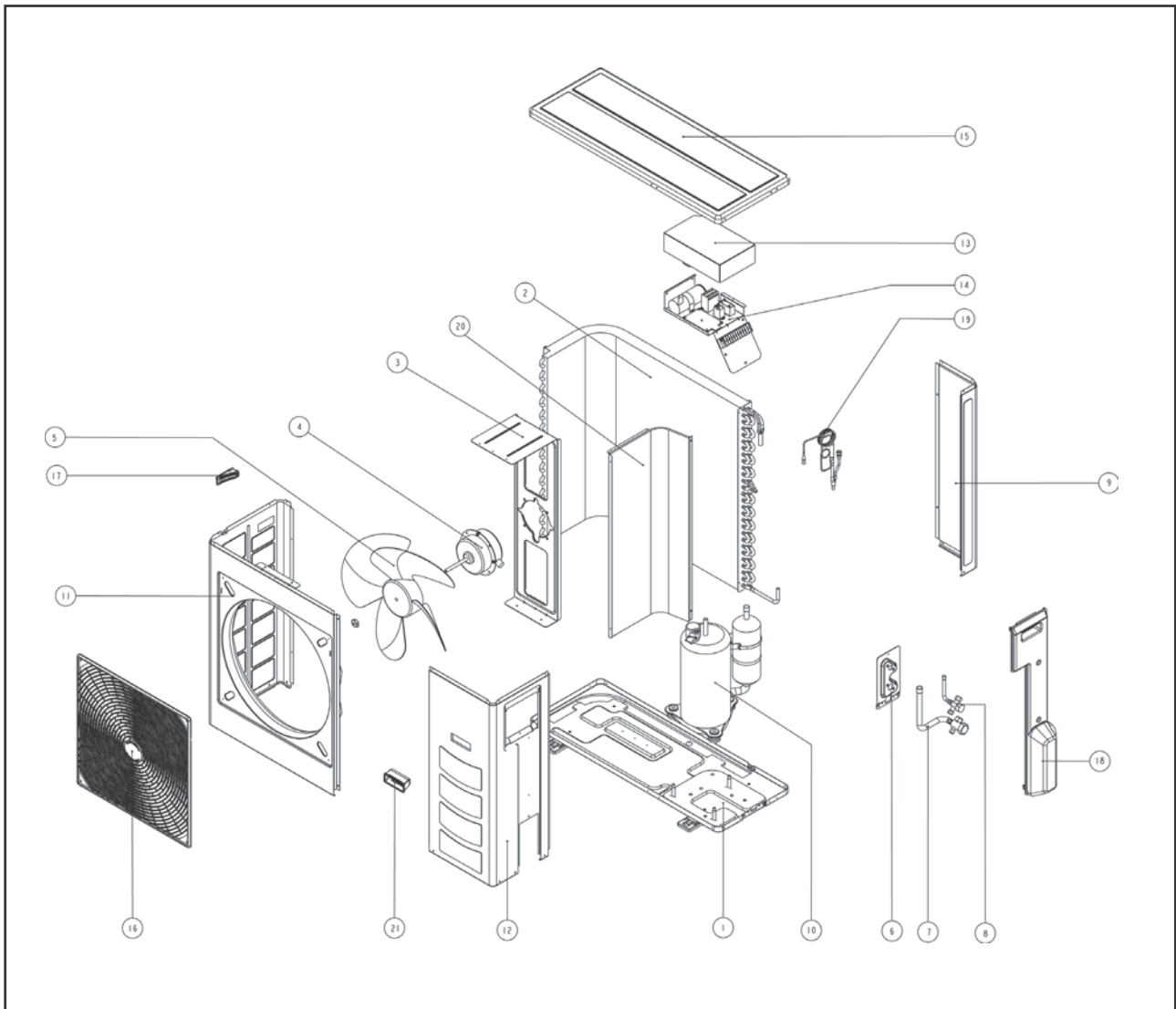

No.	Descriptions	Part No
1	Assy. Base Pan	A50014073884
2	Assy. Outdoor Coil	
	ALC 25C/28C	A50024070959
	A5LC 25C/28C	A50024079238
3	Motor Bracket	A01014070948
4	Fan Motor	
	A5LC/ALC 25C	A03039023391
	A5LC/ALC 28C	A03039024538
5	Fan Blade	A03019023393
6	Valve Bracket	A50014073890
7	Assy. Flare Valve 3 Ways 5/8"	
	ALC 25C/28C	A50054072863
	A5LC 25C/28C	A50059023336
8	Assy. Flare Valve 2 Ways 3/8"	
	ALC 25C/28C	A50059022577
	A5LC25C	A50059023334
	Assy. Flare Valve 3 Ways 3/8"	
	A5LC28C	A50059024820
9	Back Panel, Right	A01014070950
10	Compressor	
	ALC 25C	A04019019032
	ALC 28C	A04019012828
	A5LC 25C/28C	A04019020449

No.	Descriptions	Part No
11	Front Panel, Left	A01014070947
12	Service Panel	A01014070949
13	Terminal Cover Panel	A01014070838
14	Assy. Control Panel	
	A5LC/ALC 25C	A50044073902
	ALC 28C	A50044080172
	A5LC 28C	A50044080648
15	Top Panel	A01014070596
16	Assy. Front Grille	A50124072880
17	Plastic Handle, Side	A12014057948
18	Assy. Valve Cover	A50124073905
19	Assy. Cap Tube	
	ALC 25C	A50024073895
	A5LC 25C	A50024078311
	A5LC 28C	A50024079593
20	Partition	A01014070951
21	Plastic Handle, Front	A12014070955

MODEL: A5LC / ALC 20CR

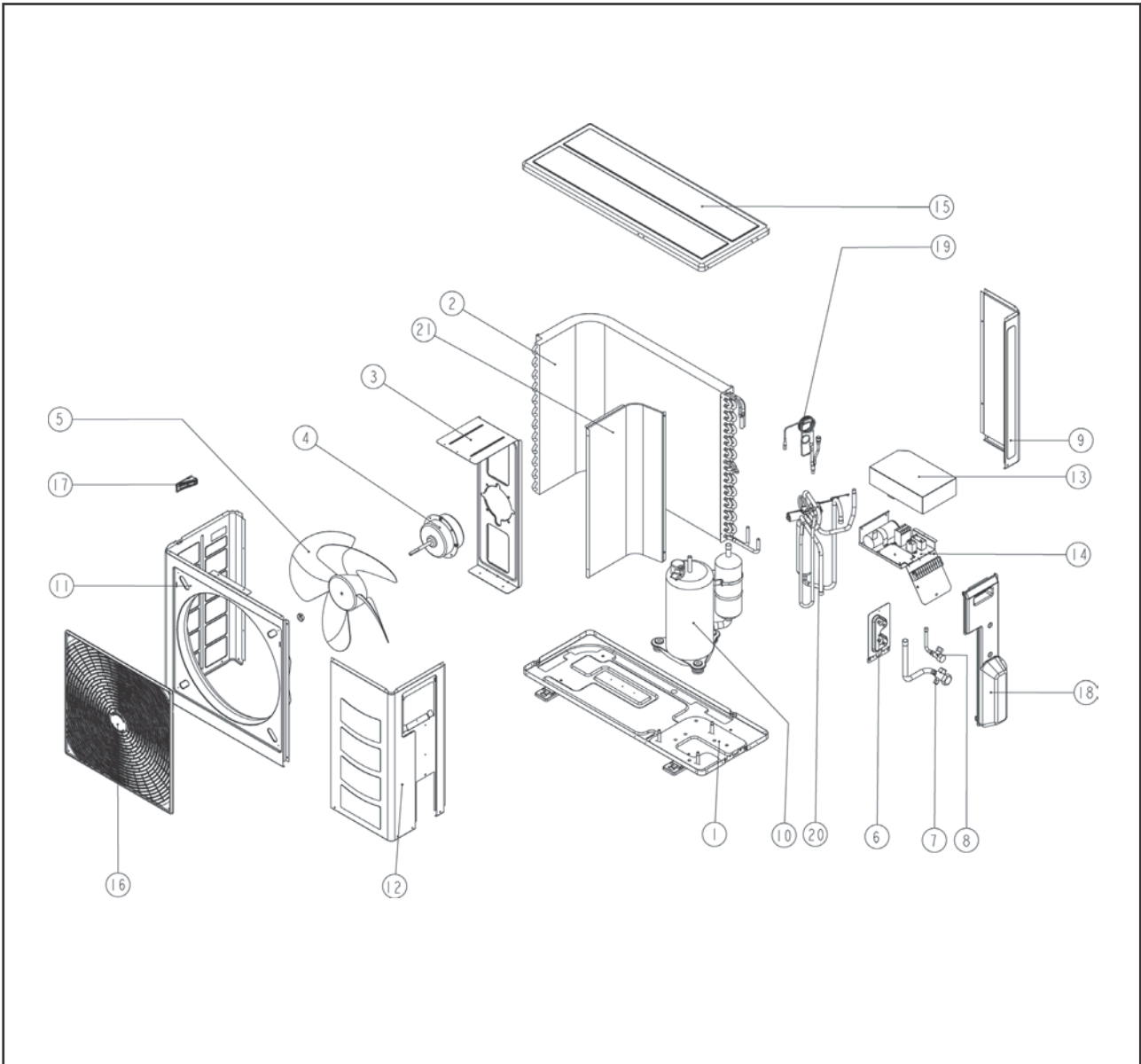

No.	Descriptions	Part No
1	Assy. Base Pan	A50014073884
2	Assy. Outdoor Coil	
	ALC 20CR	A50024077089
	A5LC 20CR	A50024075143
3	Motor Bracket	A01014070601
4	Fan Motor	A03039023391
5	Fan Blade	A03019023393
6	Valve Bracket	A50014072861
7	Assy. Flare Valve 3 Ways 5/8"	
	ALC 20CR	A50054072863
	Assy. Flare Valve 3 Ways 1/2"	
	A5LC 20CR	A50059023335
8	Assy. Flare Valve 2 Ways 1/4"	
	ALC 20CR	A50059022156
	A5LC 20CR	A50059023334
9	Back Panel, Right	A01014070599
10	Compressor	
	ALC 20CR	A04019018334
	A5LC 20CR	A04019021361

No.	Descriptions	Part No
11	Front Panel, Left	A01014070597
12	Service Panel	A01014070598
13	Terminal Cover Panel	A01014070838
14	Assy. Control Panel	
	ALC 20CR	A50044077198
	A5LC 20CR	A50044077200
15	Top Panel	A01014070596
16	Assy. Front Grille	A50124072880
17	Plastic Handle	A12014057948
18	Assy. Valve Cover	A50124072885
19	Assy. Cap Tube	
	ALC 20CR	A50024076304
	A5LC 20CR	A50024078285
20	Assy. 4 Way Valve	
	ALC 20CR	A05019004158
	A5LC 20CR	A05019016937
21	Partition	A01014070603

MODEL: A5LC / ALC 25CR, A5LC / ALC 28CR

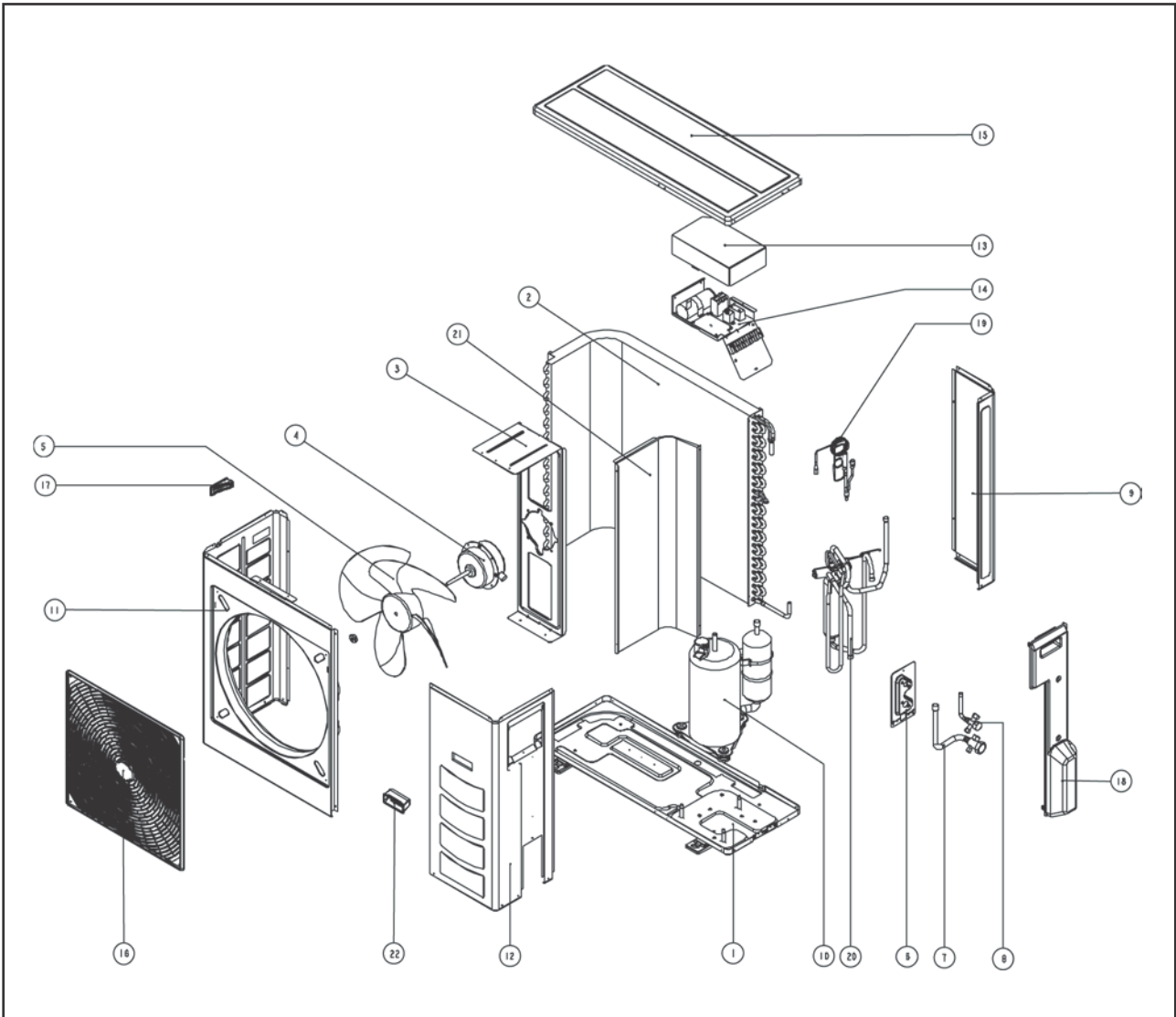

No.	Descriptions	Part No
1	Assy. Base Pan	A50014073884
2	Assy. Outdoor Coil	
	ALC 25CR/28CR	A50024077092
	A5LC 25CR/28CR	A50024075147
3	Motor Bracket	A01014070948
4	Fan Motor	
	A5LC/ALC 25CR	A03039023391
	A5LC/ALC 28CR	A03039024538
5	Fan Blade	A03019023393
6	Valve Bracket	A50014073890
7	Assy. Flare Valve 3 Ways 5/8"	
	ALC 25CR/28CR	A50054072863
	A5LC 25CR/28CR	A50059023336
8	Assy. Flare Valve 2 Ways 3/8"	
	ALC 25CR/28CR	A50059022577
	A5LC 25CR	A50059023334
	Assy. Flare Valve 3 Ways 3/8"	
	A5LC28CR	A50059024820
9	Back Panel, Right	A01014070950
10	Compressor	
	ALC 25CR	A04019019032
	ALC 28CR	A04019012828
	A5LC 25CR/28CR	A04019020449

No.	Descriptions	Part No
11	Front Panel, Left	A01014070947
12	Service Panel	A01014070949
13	Terminal Cover Panel	A01014070838
14	Assy. Control Panel	
	A5LC/ALC 25CR	A50044077198
	ALC 28CR	A50044080649
	A5LC28CR	A50044080650
15	Top Panel	A01014070596
16	Assy. Front Grille	A50124072880
17	Plastic Handle, Side	A12014057948
18	Assy. Valve Cover	A50124073905
19	Assy. Cap Tube	
	ALC 25CR	A50024077286
	ALC 28CR	A50024080186
	A5LC 25CR	A50024078311
	A5LC 28CR	A50024080312
20	Assy. 4 Way Valve	
	ALC 25CR/28CR	A05019004158
	A5LC 25CR/28CR	A05019016937
21	Partition	A01014070951
22	Plastic Handle, Front	A12014070955



While utmost care is taken in ensuring that all details in the publication are correct at time of going to press, we are constantly striving for improvement and therefore reserve the rights to alter model specifications and equipment without prior notice. Details of specifications and equipment are also subject to change to suit local conditions and equipments and not all models are available in every market.