

AOYUE[®] SP2000

**Environment Friendly
Solder Pot**

Instruction Manual

Thank you for purchasing the Aoyue SP2000 Solder Pot.
Please read the manual before using the unit.
Keep manual in accessible place for future reference.

Manufacturer:

AOYUE TONGYI ELECTRONIC EQUIPMENT FACTORY

Jishui Industrial Zone, Nantou, Zhongshan City,

Guangdong Province, P.R.China

<http://www.aoyue.com>

This manual is designed to familiarize and instruct the technician with the proper operation and maintenance of the equipment. The "Care and Safety Precautions" section explains the hazards of using any type of soldering or reworking device. Please read carefully and observe the guidelines in order to maximize usage and minimize the risk of injury or accidents .

REPLACEMENT PARTS

Fan Model#

1025X86.220V
1025X86.110V

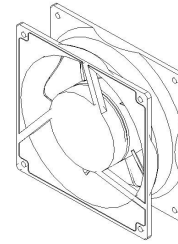

Crucible with integrated heating element and Temperature sensor

Model

103411

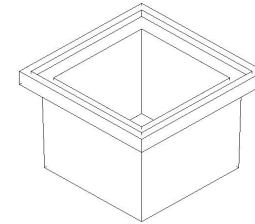

Filter pad Model#

3055D



BASIC TROUBLESHOOTING GUIDE

PROBLEM 4: THE TEMPERATURE ADJUSTMENT KNOB IS NOT WORKING

Description: Turning of the temperature setting knob does not alter the display or show the set temperature level nor does the set temperature level changes with the turn of the knob.

CAUSE & SOLUTION:

The temperature knob may be damaged and needs to be replaced. Have the unit serviced by a certified technician.

PROBLEM 5: DISPLAY SHOWS UNRECOGNIZABLE CHARACTERS

SOLUTION: Turn on the main power switch Off and then On again , if the problem persists have the unit serviced by a qualified technician.

PROBLEM 6: OTHER PROBLEMS NOT MENTIONED IN THIS DOCUMENT

SOLUTION: Please bring the unit to a certified service station.

TABLE OF CONTENTS

Product Description	4
Package Inclusion	5
Specifications	6
Functions and Features	7
Safety Precautions	8
Control Panel Guide	9
Operating Guidelines	10 — 12
Initial Procedures	
Working with the solder pot	
Dip soldering	
Tinning	
Care and Maintenance	13 — 20
Replacing filter pad	
Replacing Fan	
Removing heating element	
Attaching heating element	
Basic Troubleshooting Guide	21 — 22
Replacement Parts	23

PRODUCT DESCRIPTION

The Aoyue SP2000 solder pot is a highly durable general purpose industrial solder pot specially made for lead-free applications.

It has a patented environment friendly design that efficiently filter solder fumes while minimizing unwanted residue.

Its ceramic crucible is made of highly durable material that is well suited for lead free processes . While at the same time decreases residue due to its non metallic composition.

The poisonous fumes generated during the soldering are quickly exhaust and filtered away thus significantly reducing byproducts of the soldering process.

A microprocessor controlled heater ensures precise temperature regulation ensuring protection from heat damage to components and overheating.

Finally, the unique, innovative design with bright digital display provides precision, safety, and ease of use to match all soldering requirements.

BASIC TROUBLESHOOTING GUIDE

PROBLEM 1: THE UNIT HAS NO POWER

1. Check if the unit is switched ON.
2. Check the fuse. Replace with the same type if fuse is blown.
3. Check the power cord and make sure there are no disconnections.
4. Verify that the unit is properly connected to the power source.

PROBLEM 2: TEMPERATURE DISPLAYS BLINKING OFF

Description: Upon switching on the unit the display momentarily shows the set temperature then switches to display a blinking OFF.

CAUSE & SOLUTION:

The thermal sensor may be broken or connection is loose, if unit has been recently opened for servicing, it is most probably a loose connection.

Reattach the sensor connector securely .

PROBLEM 3: TEMPERATURE IS NOT INCREASING

Description: Actual temperature reading is not increasing or decreasing based on desired level. A constant display of relatively low temperature reading on the display panel.

CAUSE & SOLUTION:

The thermal sensor may be shorted or Heating element is damaged , if unit has been recently opened double check the wires for loose connection or short.

The heating element may be broken and needs to be replaced. Refer to care and maintenance section of this booklet for instruction on how to replace heating element and connection issues.

CARE AND MAINTENANCE

8. Reattach the top and bottom part of the chassis, then reattach screws I, J, K, and L.

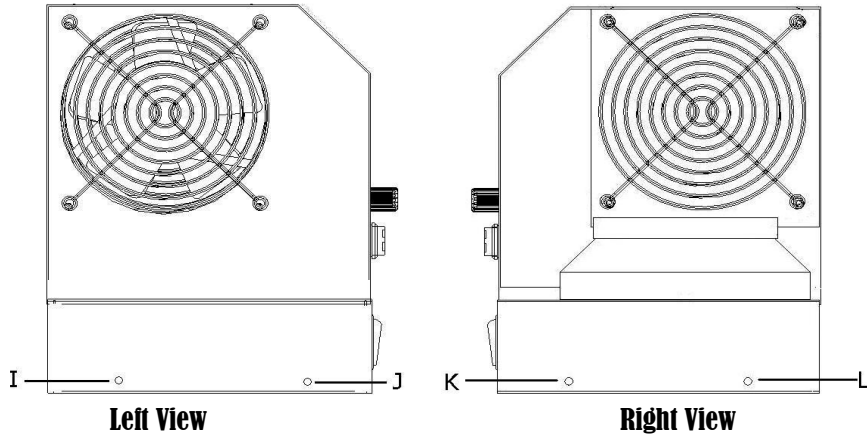

9. The unit is now ready for use. If unit fails to start up or work properly after replacement of heating element please refer to our trouble shooting guides on this manual.

Additional notes:

Hardened and cold solder may slide out entirely from the crucible when subjecting the unit to tilts or movements. This is one way of cleaning the crucible of solder, or when a change from standard to lead free solder is required.

It is advised to remove the solder before doing any servicing or maintenance on the equipments so as not to encounter any accidents.

⚠ IMPORTANT: When pouring hot solder out of the crucible use heat resistant gloves to tilt the entire unit to the side until a steady stream of solder flows out. Always use proper safety equipments when handling hot molten solder.

PACKAGE INCLUSION

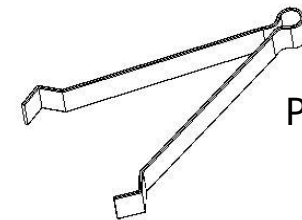
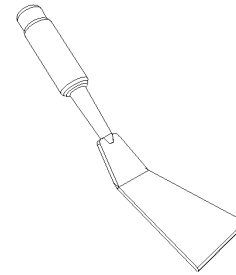
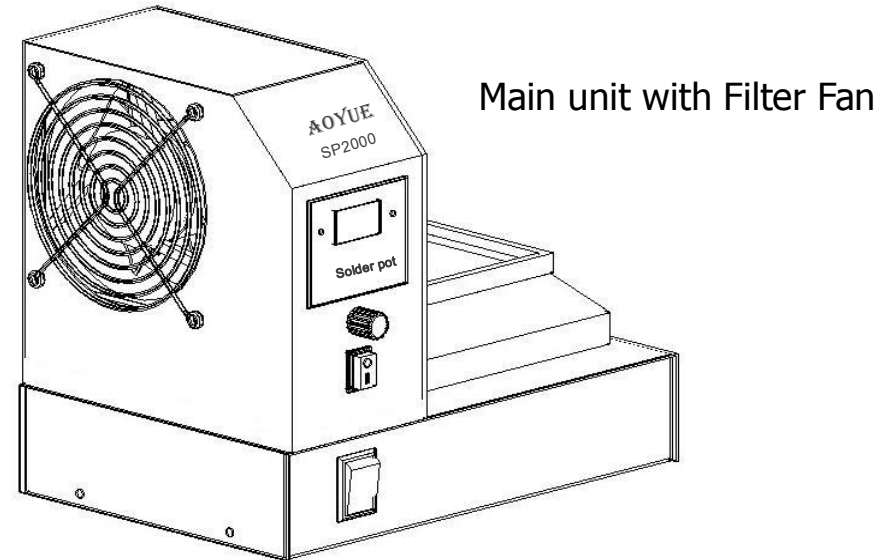

PCB Holder

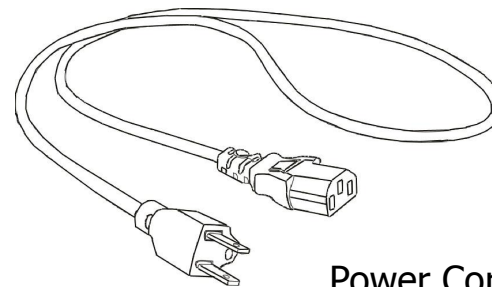

Power Cord

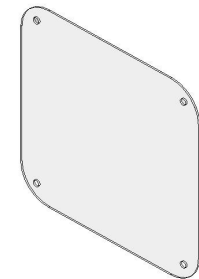

Filter Pad

SPECIFICATION

MAIN STATION

Power Input :	available in 110V / 220V
Station Dimensions:	265(w) x 180(d) x 220 (h) mm
Weight:	3.8 Kg
Power:	600W
Temperature Range:	200°C - 480°C
Heating Element:	Band Style Heating Element
Time to melt full pot 480°C:	20 minutes
Capacity:	3Kgs
Crucible internal dimension:	77(w) x 77(d) x 60 (h) mm
Crucible external dimension:	104(w) x 104(d) x 70(h) mm

CARE AND MAINTENANCE

5. Insert the crucible with integrated heating element module back into the main top chassis.

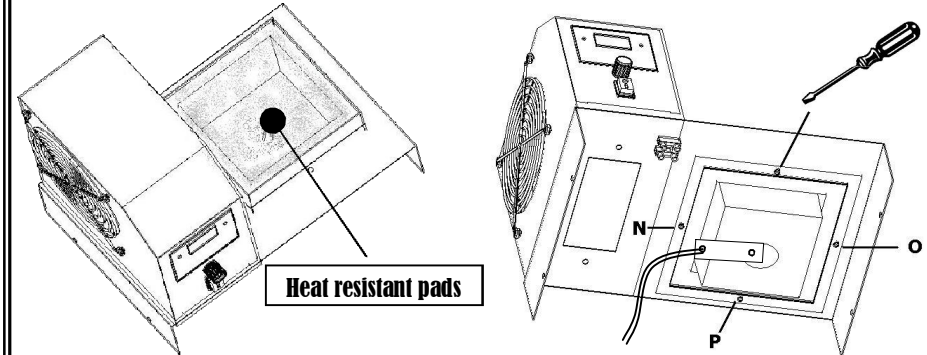

6. Attach screws M, N, O, P, and grounding plate as shown above.
7. Reattach the heating elements wires to the connecting grid, insert the tip of the heating element wires as shown below and retighten the screws to ensure connection.

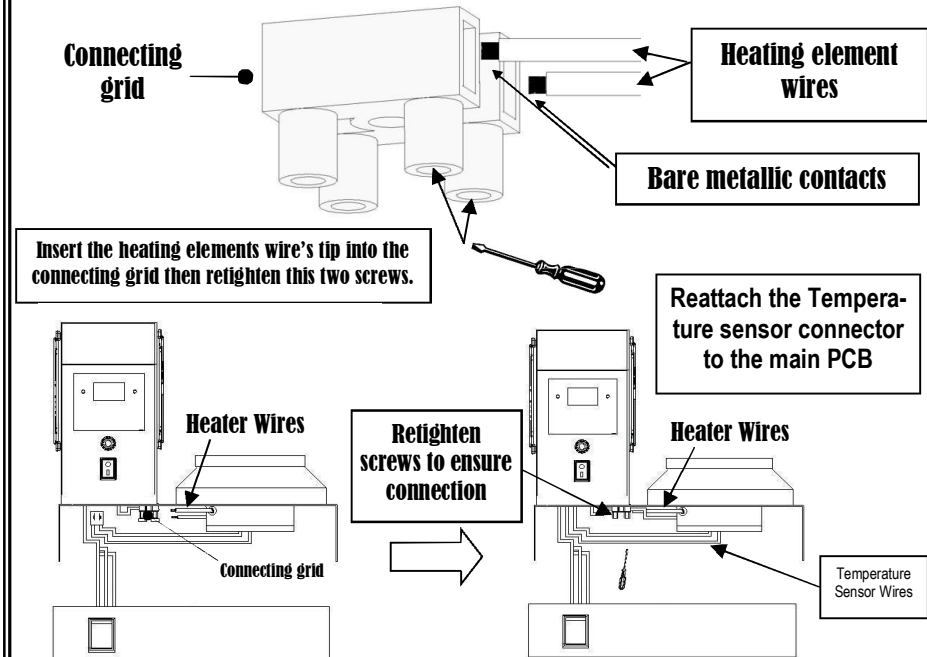

CARE AND MAINTENANCE

B. Attaching the new Crucible w/heating element

1. Prepare the new crucible with integrated heating element. Take the new crucible with integrated heating element out of its packaging and ensure that all wires are connected firmly at the body of the crucible.
2. Slide the crucible back into the crucible dock
3. Fasten tightly screws to hold the crucible in a firm grip.

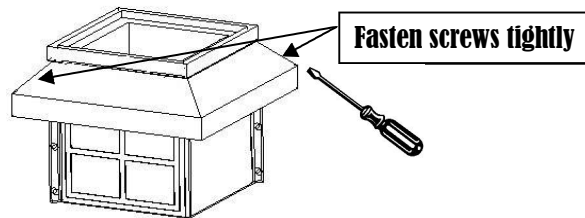

4. Pass the Temperature wire thru the hole located at the bottom part of the top chassis, and the Temperature sensor wire thru hole located at each side. Rearrange the heat resistant pads so that the crucible with heating element would slide in smoothly. Attach the earth grounding plate back to the center of the crucible.

Optional: The bottom plate where the temperature sensor wires passes thru may be removed for easy insertion of crucible and heat resistant pads. Reattach this plate after the heat resistant pads are properly inserted.

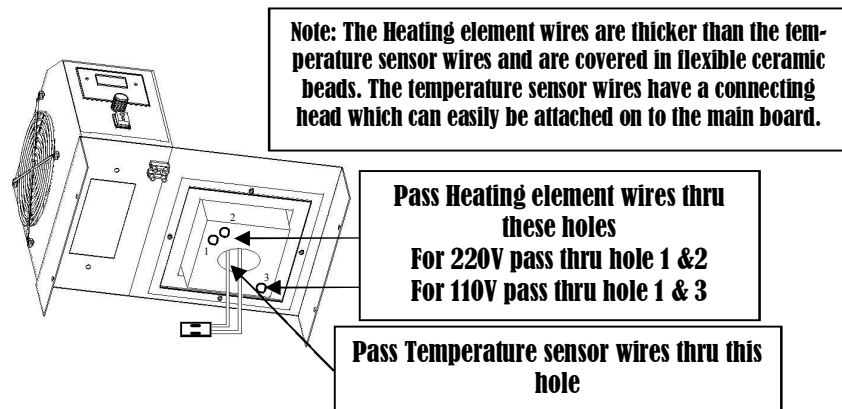

FUNCTIONS and FEATURES

- Microprocessor-controlled ESD safe equipment.
- Environmentally friendly system combining smoke filter and solder pot in one sophisticated package.
- Digital display of set and actual air temperature, with knob type control for precision and ease of use.
- Low residue crucible ensures a pure solder.
- The crucible is made of highly durable ceramic which can withstand temperatures of over 400°C.
- Integrated smoke absorber fan with filter pad to efficiently and effectively absorb and filter harmful fumes.
- Compatibility with lead free process.
- Specially designed casing to prevent spillage.

SAFETY PRECAUTIONS



CAUTION: Improper usage can cause serious injury to personnel and/or damage to equipment and work area. For your own safety, please observe the following precautions.

- Check each component after opening the package to make sure everything is in good condition. If there are any suspected damage, do not use the item and report the issue to your vendor.
- Turn OFF the power switch and unplug the device from the power source when moving the device from one place to another.
- Do not strike or subject the main unit (and all its components) to physical shock.
- Handle with care.
 - Never drop or sharply jolt the unit.
 - Contains delicate parts that may break if the unit is dropped.
- Make sure the equipment is always grounded. Always connect power to a grounded receptacle.
- Temperature may reach as high as 480°C when switched ON.
 - Do not use the device near flammable gases, paper and other flammable materials.
 - Do not touch heated parts, which can cause severe burns.
 - Do not touch metallic parts near the tip.
- Disconnect the plug from the power source if the unit will not be used for a long period. Turn off power during breaks, if possible.
- Use only genuine replacement parts.
 - Turn off and let the unit cool down before replacing any part.
- Soldering process produces smoke, use on well ventilated places.
- Do not alter the unit in any manner.
- Do not operate near inflammable, flammable and combustible material and chemicals.
- Use proper safety procedures when handling equipments of extremely hot temperatures.

CARE AND MAINTENANCE

6. Loosen the screws on the sides of the crucible dock . This would release the grip of the crucible dock on the crucible.
7. Loosen the screws on the crucible clamp.

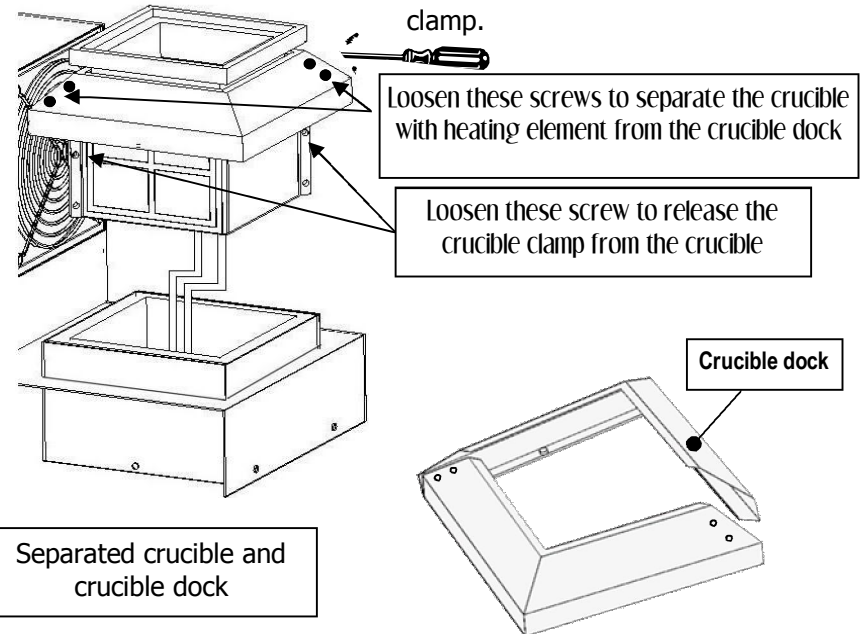

The Crucible dock can be expanded a little to allow enough room to extract the crucible/crucible clamp. After which the crucible clamp can be detached from the crucible.

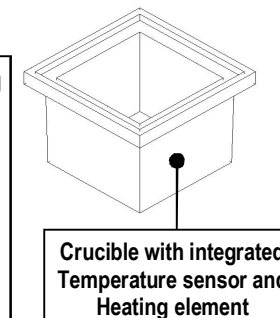

WARNING: If heating element is found to be faulty do not attach to the unit. Replace crucible with a new and working heating element.

CARE AND MAINTENANCE

3. Loosen screw on the grid connector to detach the heater wires.

Note: Detach the two heater wires, and temperature sensor connector located at the back of the control board.

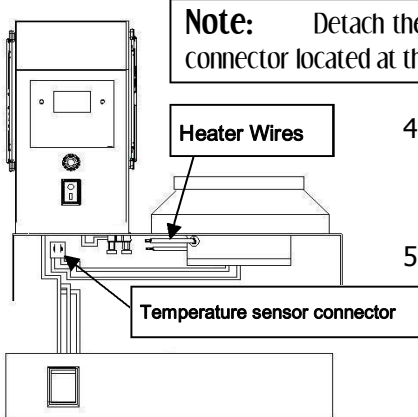

4. Remove screws M, N, O, P, and the earth grounding plate at the center of the crucible. Then carefully pull out the crucible.
5. The crucible together with the heating element, thermal sensor and crucible dock would come out in one piece, leaving the heat resistant pads inside the chassis.

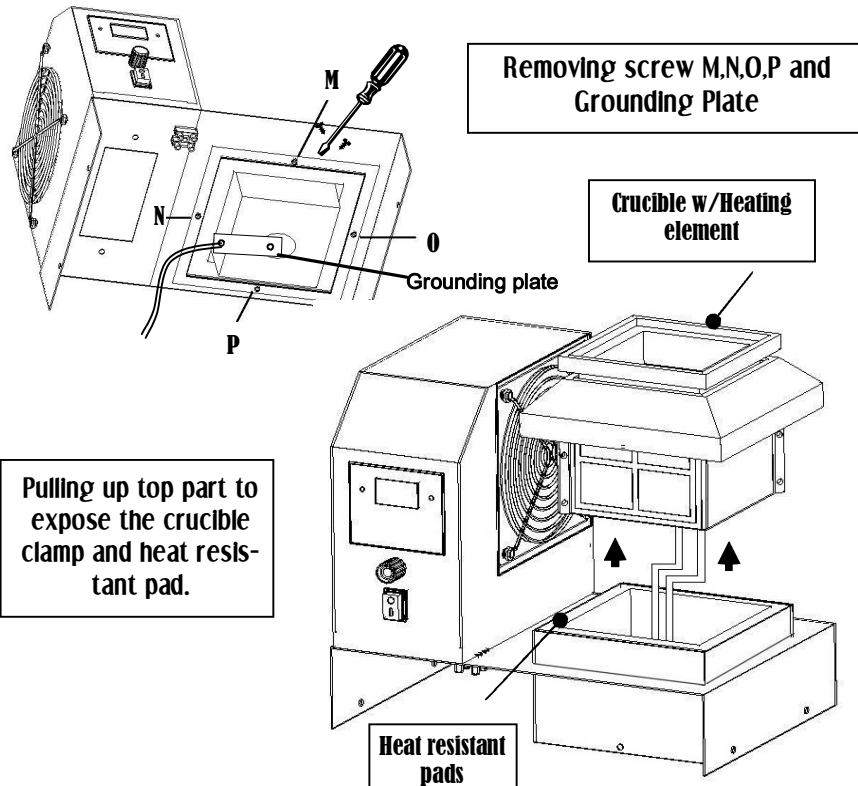

CONTROL PANEL GUIDE

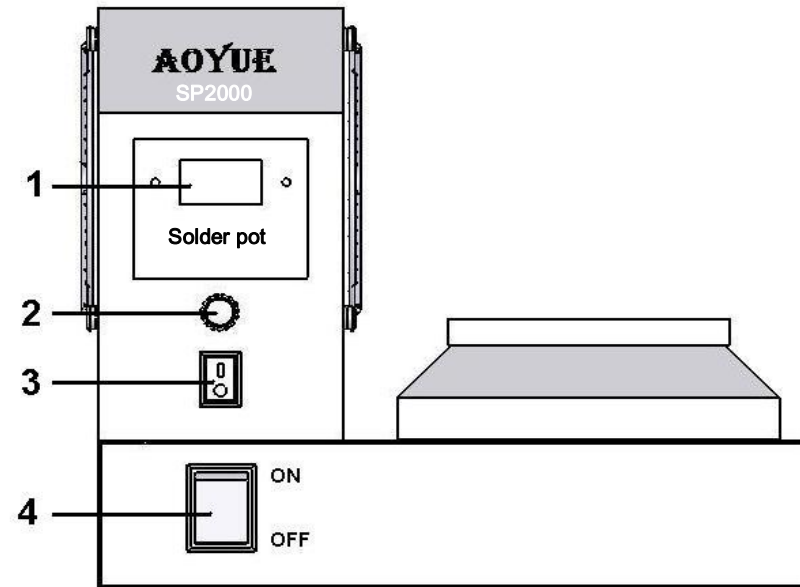

LEGEND:

- 1 — Digital temperature display
- 2 — Temperature Adjustment knob
- 3 — Smoke absorption switch
- 4 — Main power switch



IMPORTANT REMINDERS:

1. Make sure the equipment is placed on a flat stable heat resistant surface.
2. Ensure all function switches are OFF prior to plugging in.
3. Ensure all terminal connections are properly secured.

OPERATING GUIDELINES

NOTE: Please refer to the **CONTROL PANEL GUIDE** page for buttons and display panel directory.

I. INITIAL PROCEDURES

1. Plug the device to the main power source using the power cord provided in the package.
2. For empty solder pots, turn on the main power switch ("4" from the panel) to start preheating crucible but make sure that the smoke filtering switch is turned off ("3" from the panel).
3. The digital display ("1" from the panel) will momentarily show the current set temperature then changes to display the actual temperature of the solder pot.
4. Turn the temperature adjustment knob ("2" from the panel) to the desired setting (recommended is 400° C) and wait for 15-20 minutes required preheating time.
5. After pre-heating, turn ON the smoke filtering function ("3" from the panel) and put in about 200 grams of solder wire inside the crucible to melt.
6. When solder wires have molten, you can now put in Solder bars to melt and fill up the Solder Pot. You may opt to reset temperature setting at this point to your desired temperature.

⚠ IMPORTANT: Take caution on solid solder bars placed inside the crucible, ensure that the solid solder bars will not flip over when it has began to melt which may cause serious injury.

CARE AND MAINTENANCE

Replacing the heating element with crucible and sensor

In cases where the heating element has been worn out, the heating element/ Crucible may be replaced as follows:

A. Removing the old heating element with crucible

1. Remove screws I, J, K, and L. These are located at each sides of the bottom chassis. This will enable us to lift up the top part of the unit.

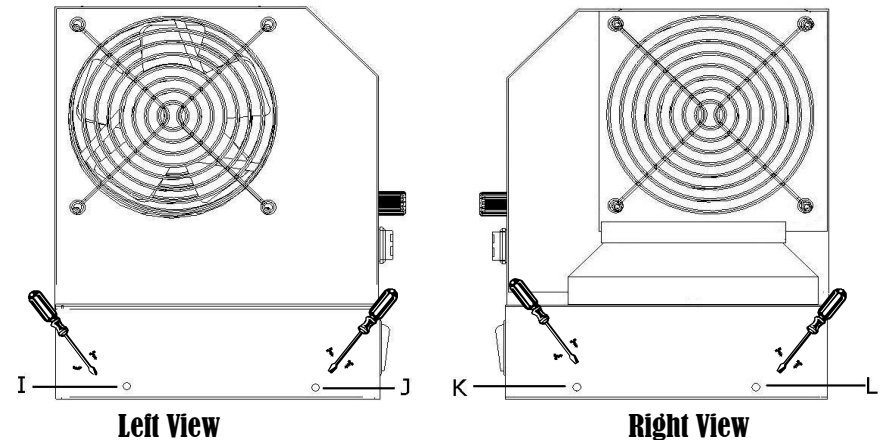

2. Detach the bottom part of the unit as shown. Be careful not to pull too hard on the top and bottom part of the chassis so as not to damage the wires attached to both sides.

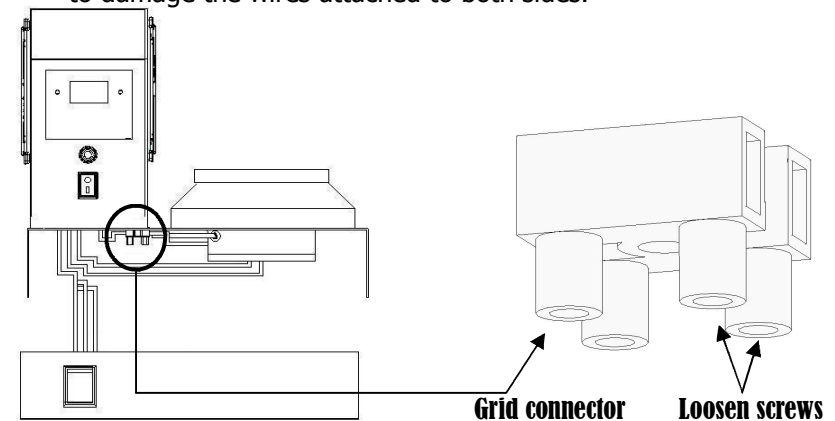

CARE AND MAINTENANCE

4. Remove the wire mesh and filter pad from the exhaust module.
5. Clean the filter pad or replace it with a new one , place filter pad back into the exhaust module .
6. Secure the filter pad by fitting the wire mesh on top of the filter pad.
7. Replace the exhaust module back into the main unit attach the fan guard and exhaust module securely with screws A, B , C and D (fig. 1 page 13).

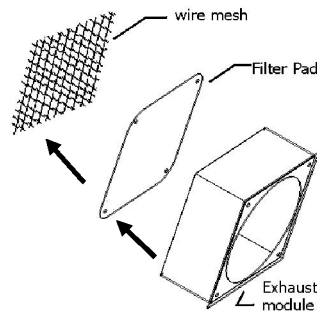

Replacing the Fan

1. Follow steps 1-3 of "replacing/cleaning the filter pad"
2. Remove Screws E, F, G, and H as shown.

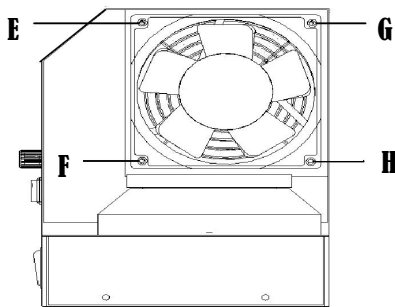

3. Detach the fan's power connector from the main unit (note: the bottom chassis may need to be removed to reach the fan's other wire see " replacing the heating element guide for detaching bottom part").

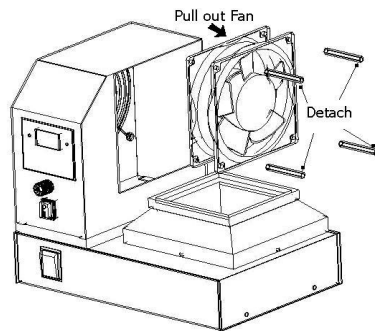

4. Pull out the Fan.
5. Attach the new fan's power wires to the main unit.
6. Insert the fan back into the main unit. Reattach Screws E,F,G,H.
7. Reinsert the exhaust module back into the main unit and attach the fan guard and exhaust module securely with screws A, B , C and D (fig.1 page 13).

OPERATING GUIDELINES

II Working with the solder pot

A. For dip soldering printed circuit boards:

- Prepare the PCB to be soldered. Insert all thru hole components into the printed circuit board.
- Use a tong to hold the PCB and briefly dip the underside of the PCB into the solder pot.
- Smoke generated from the process will then be quickly filtered thru the filter pad.
- Continue dip soldering PCBs.
- When all the PCB are soldered. Turn off the smoke absorption switch and then switch off the main power.

B. For tinning solder tips, stranded wires and pre-tinning small electrical parts:

- Prepare the items to be tinned. Ensure items are clean and free from unwanted dirt or oil.
- Use tweezers or pliers to hold small components and briefly dip the tip of the components into the solder pot.
- Smoke generated from the process will then be quickly filtered thru the filter pad.
- Continue tinning items.
- When all the work is finished. Turn off the smoke absorption switch and then switch off the main power.

 **WARNING:** Contents of the solder pot can still be very hot for several hours after usage, extreme caution should be followed when handling for storage or placement.

OPERATING GUIDELINES

III. Illustrations



- Before dipping into the solder pot



- During dip soldering
- Fumes are quickly filtered

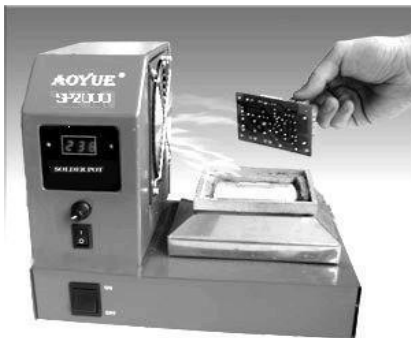

- After dip soldering
- Fumes are still being filtered
- Board is ready for use

CARE AND MAINTENANCE

Replacing the filter pad

Filters should be cleaned and replaced regularly to avoid dirt which can clog the air passage. More importantly, this will also effectively clean the toxic fumes produced during soldering process.

Replacing/ cleaning the filter pad

1. Turn off the unit and unplug from the electrical source. Let the equipment cool for several hours until all solder has hardened and entire unit is cool to touch before doing any servicing to the unit.

⚠ WARNING: Contents of the solder pot can still be molten even though the upper layers seems to have hardened. it is best to leave the soldering pot to cool for 8 hours.

2. Remove screws A B C and D as shown below.

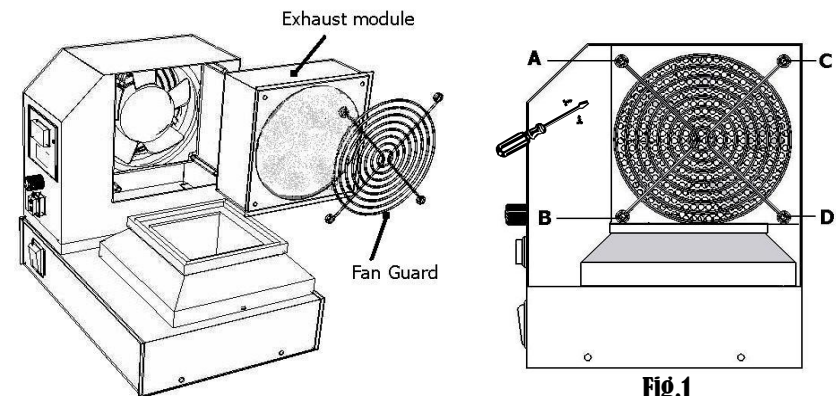

3. Remove the Fan guard and pull out the exhaust module as shown above.