

LASER MFP
SP1100SF
Aficio SP1100SF

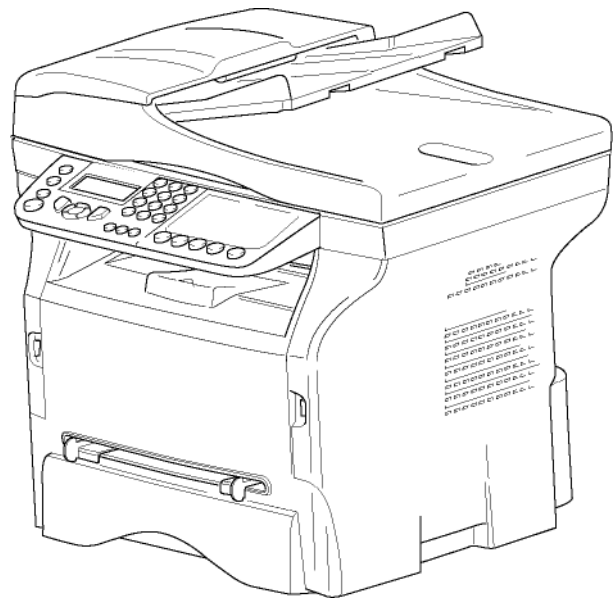

User's Guide

Read this manual carefully before you use this machine and keep it handy for future reference.
For safe and correct use, be sure to read the Safety Information in this manual before using the machine.

Contents

		<i>Device connection</i>	16
		<i>Device initial setup</i>	17
		Paper insertion in the manual input tray	18
Security	1	Copy	19
Security directives	1	Simple copy	19
Laser safety	1	ECO mode copy	19
<i>For Europe/Asia</i>	1	Sophisticated copy	19
Certification	2	ID Card Copy mode	20
Declaration of conformity	2	Special setup for the copy	20
<i>Notice to Users in EU Countries</i>	2	<i>Resolution setup</i>	20
<i>Notice to Users Accessing Analog PSTN in EU Countries</i>	2	<i>Zoom setup</i>	21
Symbols for the main power switch	2	<i>Analysis origin setup</i>	21
Positions of Warning and Caution labels on the machine	3	<i>Contrast setup</i>	21
Notice to users (New Zealand)	4	<i>Brightness setup</i>	21
Environment	5	<i>Paper type setup</i>	21
Batteries and rechargeable batteries	5	<i>Paper tray selection</i>	21
The product	5	<i>Sheet-feed analysis margins setup</i>	22
<i>Users in the EU, Switzerland and Norway</i>	5	<i>Flat-bed analysis margins setup</i>	22
<i>All Other Users</i>	5	<i>Left and right printing margins setup</i>	22
Software use license	6	<i>Top and bottom printing margins setup</i>	22
<i>Definition</i>	6	<i>Format paper setup</i>	22
<i>License</i>	6	Fax	23
<i>Property</i>	6	Fax transmission	23
<i>Duration</i>	6	<i>Print a header page</i>	23
<i>Warranty</i>	6	<i>Immediate transmission</i>	23
<i>Responsibility</i>	6	<i>Delayed transmission</i>	23
<i>Development</i>	6	<i>Transmission with auto redial</i>	24
Registered trademarks	7	Fax reception	24
Notice	7	Fax answering device	24
Installation	8	<i>Saving an access code</i>	24
Location conditions	8	<i>Activating / Deactivating the answering device</i>	25
<i>Cautions of use</i>	8	<i>Printing fax messages stored in the memory</i>	25
Safety information	9	Fax rerouting (Forwarding)	25
<i>Safety During Operation</i>	9	<i>Activating rerouting</i>	25
<i>Power Supply</i>	10	<i>Setting the re-direction contact</i>	25
<i>For Fax or Telephone</i>	10	<i>Printing rerouted documents</i>	25
Rules for use symbols	10	Rerouting fax messages to a USB memory key	25
Terminal description	11	<i>Activating rerouting</i>	25
Command panel	12	<i>Printing rerouted documents</i>	25
<i>Presentation</i>	12	Transmission waiting queue	26
<i>Entering Characters Using the Alphanumeric keypad</i>	12	<i>Performing immediate transmission from the waiting queue</i>	26
<i>Accessing terminal functions</i>	13	<i>Consulting or modifying the waiting queue</i>	26
Packaging contents	14	<i>Deleting a transmission in memory</i>	26
Device installation	14	<i>Printing a document in waiting or in deposit</i>	26
Installing the document feeder	14	<i>Printing the waiting queue</i>	26
Loading paper	14	Cancelling a transmission in progress	26
<i>Loading paper in the paper Tray</i>	14	Deposit and Polling	26
Handling of paper	14	<i>Placing a document in deposit</i>	27
<i>Humidity control</i>	14	<i>Polling a deposited document</i>	27
Handling the unit	15	Parameters/Setup	28
<i>Operator shocks</i>	15	Date/Time	28
<i>Moving the unit</i>	15	Summer time / Winter time setting	28
<i>Handling the Toner Cartridge</i>	15	Your fax number/Your name	28
Feed cassette paper insertion	15	Type of network	29
Cartridge installation	15	Geographical settings	29
Paper delivery stop	16	<i>Country</i>	29
Starting your device	16	<i>Telecommunication Network</i>	29
		<i>Language</i>	29
		Local prefix	29
		Transmission report	30

Document feed type	30	<i>Graphical presentation</i>	46
Economy period	30	<i>Device management</i>	46
Reception Mode	30	Selecting the current device	46
Reception without paper	31	Status of the connection	47
Number of copies	31	Device parameters	47
Fax or PC reception	31	<i>Display the consumable status</i>	47
Adjust to page	31	Companion Suite Pro functionalities	47
Received faxes reduction mode	31	<i>Document analysis</i>	47
Technical Parameters	32	Analysis with Scan To	47
Printing the functions list	33	Character recognition software (OCR)	48
Printing the logs	33	<i>Printing</i>	49
Print the list of setups	33	Printing on the multifunction machine	49
Lock the machine	33	Printing in duplex mode with the	
<i>Lock the keyboard</i>	33	multifunction machine	49
<i>Lock the numbers</i>	34	Address book	50
<i>Lock the Media service</i>	34	<i>Add a contact to the terminal address book</i>	50
Read the counters	34	<i>Add a group to the terminal address book</i>	51
<i>Sent pages counter</i>	34	<i>Manage the address book</i>	51
<i>Received pages counter</i>	34	Modify the information related to a contact	51
<i>Scanned pages counter</i>	34	Modify a group	51
<i>Printed pages counter</i>	34	Delete a contact or a group from the address	
Display the consumables status	34	book	51
Calibrate your scanner	34	Print the address book	51
Directory	35	<i>Import or export an address book</i>	51
Creating Speed dial	35	Save / Export your address book	51
Creating Group dial	35	Import an address book	52
Modifying a record	35	Fax communications	52
Deleting a record	35	<i>Presentation of the Fax window</i>	52
Printing the directory	36	<i>Send a fax</i>	52
Saving/Restoring the directory (Smart card		Send a fax from the hard disk or the terminal	52
option)	36	Send a fax from application	53
Games and Calendar	37	<i>Receive a fax</i>	53
Sudoku	37	<i>Follow-up of fax communications</i>	53
<i>Print a grid</i>	37	The outbox	54
<i>Print the solution to a grid</i>	37	The send memory (items sent)	54
Calendar	37	The outbox log	54
USB memory key	38	The inbox log	54
Use of the USB memory key	38	<i>Fax parameters</i>	54
<i>Print your documents</i>	38	Access to fax parameters	54
Print the list of files located in the key	38	Description of the tab Log and Report	54
Print the files located in the key	38	Description of the tab Fax Parameters	55
<i>Delete your files located in the key</i>	39	Cover sheet	55
Analyse the USB memory key content	39	Creating a cover sheet	55
Save a document on a USB memory key	39	Description of the tab Cover page	56
PC Features	41	Creating a cover page template	57
Introduction	41	Software Uninstallation	58
Configuration requirements	41	<i>Uninstall the software from your PC</i>	58
Software installation	41	<i>Uninstall the drivers from your PC</i>	58
<i>Installing the full software package</i>	41	Uninstall the drivers using the Companion	
<i>Installing drivers only</i>	43	Suite Pro software	59
Installing the drivers using the Companion		Uninstall the drivers manually	59
Suite Pro software	43	Maintenance	60
Installing the drivers manually	44	Service	60
<i>Connections</i>	45	<i>General information</i>	60
Multifunction Terminal's Supervision	46	<i>Toner cartridge replacement</i>	60
<i>Checking the connection between the PC</i>		<i>Issues with smart cards</i>	61
<i>and the multifunction machine</i>	46	Cleaning	61
Companion Director	46	<i>Scanner reading system cleaning</i>	61
<i>Graphical presentation</i>	46	Printer cleaning	61
<i>Utilities and applications activation</i>	46	<i>Printer external cleaning</i>	61
Companion Monitor	46	<i>Document-feeder roller cleaning</i>	61
		Printer issues	62
		<i>Error messages</i>	62
		Paper jam	63
		Scanner issues	63

Miscellaneous issues	63
Communication errors	64
<i>Transmission from the feeder</i>	64
<i>Transmission from memory</i>	64
<i>Communication error codes</i>	64
<i>General codes</i>	64
PC printing issues	65
<i>PC printing via USB connection</i>	65
Firmware update	65
Specifications	66
<i>Physical specifications</i>	66
<i>Electrical specifications</i>	66
<i>Environmental specifications</i>	66
<i>Peripheral specifications</i>	66

Security

Security directives

Before turning on your device, check that the outlet that you are going to plug it into conforms to the indications shown on the information plate (voltage, current, power network frequency) located on your device. This device shall be connected to a single phase power network. The device shall not be installed on bare ground.

Batteries and rechargeable batteries, packaging and electric and electronic equipment (EEE), shall be thrown away, as specified by the Instructions of the ENVIRONMENT chapter of this manual.

Because of the device model, the power connector is the only way to disconnecting the device from the power network, that is why it is imperative to apply the following safety measures: your device shall be connected to a power outlet located nearby. The outlet shall be easily accessible.

Your device is delivered with a grounded power cord. It is imperative to connect a grounded connector to a grounded outlet connected to the building earthing.

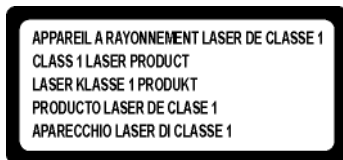

Repairs-maintenance: Repairs and maintenance should only be carried out by a qualified technician. No user serviceable parts inside the machine. To reduce the risk of electrical shock, you shall not proceed with these operations yourself, because by opening or removing the lids, you could expose yourself to two hazards:

- The laser beam can cause irreversible eye damage.
- Avoid contact with powered parts because it can lead to electrical shock with unfortunate consequences.

For installation conditions and safe use precautions, refer to chapter **Installation**, page 8.

Laser safety



CAUTION *Use of controls or adjustments or performance of procedures other than those specified in the User's Guide might result in hazardous radiation exposure.*

For Europe/Asia

This machine complies with IEC 60825-1:1993+A1:1997+A2:2001 standard, is classified as laser class 1 product and is safe for office/EDP use. It contains one class 3B laser diode, 10.72 mW max, 770-795 nm and other class 1 LEDs (280 μ W at 639 nm).

Direct (or indirect reflected) eye contact with the laser beam might cause serious eye damage. Safety precautions and interlock mechanisms have been designed to prevent any possible laser beam exposure to the operator.

Certification

Declaration of conformity



Notice to Users in EU Countries

This product complies with the essential requirements and provisions of Directive 1999/5/EC of the European Parliament and of the Council of 9 March 1999 on radio equipment and telecommunications terminal equipment and the mutual recognition of their conformity.

Notice to Users Accessing Analog PSTN in EU Countries

This product is designed to be able to access analog PSTN in all EU countries. Local PSTN compatibility is dependent on software switch settings. Please contact your service representative if relocating this product to another country. In the event of problems, please contact your service representative in the first instance.

SP1100SF/ Aficio SP1100SF: The CE declaration of Conformity is available on the Internet at URL :
http://www.ricoh.co.jp/fax/ce_doc

CE Marking Traceability Information (For EU Countries Only.)

Manufacturer:

Ricoh Co., Ltd.
3-6 Nakamagome 1-chome, Ohta-ku, Tokyo, 143-8555 Japan

Authorized representative:

Ricoh Europe PLC
66 Chiltern Street London

Symbols for the main power switch



In accordance with IEC 60417, this machine uses the following symbols for the main power switch:

- **I** means POWER ON.
- **O** means POWER OFF.

Positions of Warning and Caution labels on the machine

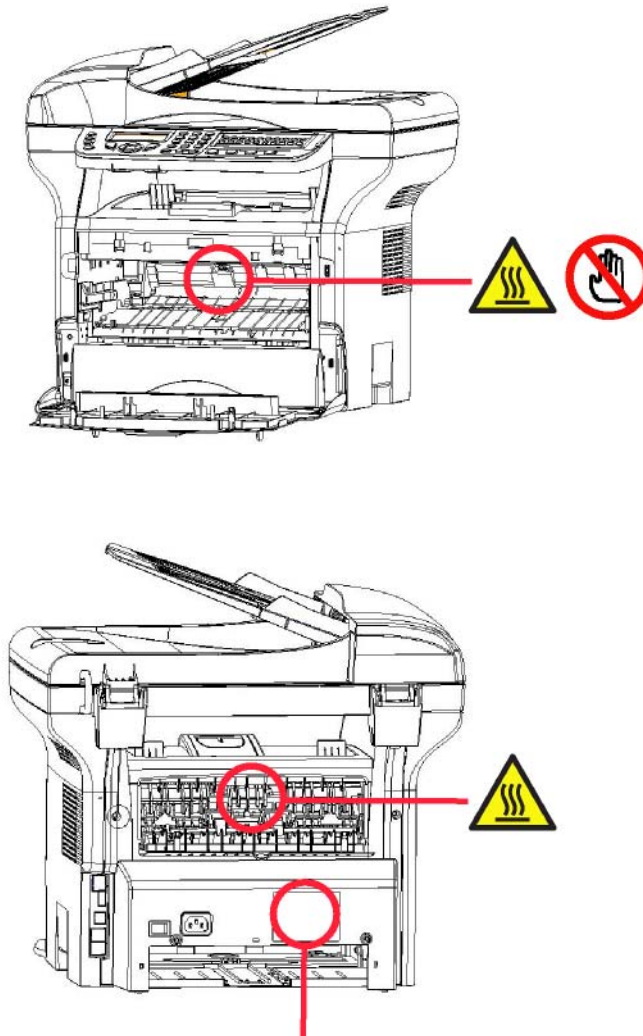
This machine has labels for  **WARNING** and  **CAUTION** at the positions shown below. For safety, please follow the instructions and handle the machine as indicated.



		CAUTION Hot surface avoid contact
ATTENTION		Surface chaude Évitez tout contact
ACHTUNG		Heiße Oberfläche Kontakt vermeiden
ATTENZIONE		Superficie calda Evitare il contatto
PRECAUCIÓN		No tocar. Zona muy caliente.
VOORZICHTIG		Heet oppervlak vermijd contact
FÖRSIKTIGT		Het yta. Rör ej.
FORSIGTIG		Varm overflade, undgå berøring
FORSIKTIG		Varm overflate, unngå kontakt
OSTRZEŻENIE		Gorąca powierzchnia nie dotykać
CUIDADO		Superficie quente Evitar contacto
POZOR		Horký povrch nedotýkat se
FIGYELEM		Ne érintse meg a forró felületeket!
TÄRKEÄÄ		Kuuma pinta älä koske.
ОСТОРОЖНО		Горячая поверхность Избегайте контакта
注意		表面高温, 请勿接触。
注意		表面高温請勿碰觸
고온주의		표면이 뜨거우므로 만지지 않도록 주의하십시오.
注意		表面が熱くなっていますので触らないでください。

APPAREIL A RAYONNEMENT LASER DE CLASSE 1
 CLASS 1 LASER PRODUCT
 LASER KLASSE 1 PRODUKT
 PRODUCTO LASER DE CLASE 1
 APARECCHIO LASER DI CLASSE 1

Notice to users (New Zealand)

- The grant of a Telepermit for any item of terminal equipment indicates only that Telecom has accepted that the item complies with minimum conditions for connection to its network. It indicates no endorsement of the product by Telecom, nor does it provide any sort of warranty. Above all, it provides no assurance that any item will work correctly in all respects with another item of Telepermitted equipment of a different make or model, nor does it imply that any product is compatible with all of Telecom's network services.
- This equipment is not capable, under all operating conditions, of correct operation at the higher speeds for which it is designed. Telecom will accept no responsibility should difficulties arise in such circumstances.
- This equipment shall not be set up to make automatic calls to the Telecom "111" Emergency Service.
- If a charge for local calls is unacceptable, the "Dial" button should NOT be used for local calls. Only the 7-digits of the local number should be dialled from your telephone. DO NOT dial the area code digit or the "0" prefix.
- This equipment may not provide for the effective hand-over of a call to another device connected to the same line.
- This device may be subject to ringing or bell tinkle when calls are made from another device on the same line. If this occurs, the problem SHOULD NOT be referred to the Telecom Faults Service.
- This equipment should not be used under any circumstances, which may constitute a nuisance to other Telecom customers. For example, repeated attempts to make unsolicited sales offers to the same number or group of numbers, such as when a block of numbers terminate on the same PABX.
- The call log incorporated in this equipment does not record all answered calls. The call log, therefore may not agree with the Telecom account which may include calls not shown on the log.
- Not all telephones will respond to incoming ring when connected to the extension socket.

Environment

The preservation of the environment is of importance to the manufacturer. The manufacturer wishes to service the installations with respect to the environment and has chosen to integrate the environmental performance in the whole lifecycle of its products, throughout manufacturing, release, use and disposal.

Batteries and rechargeable batteries

If your product contains batteries or rechargeable batteries, these shall be disposed of at the designated collecting centers.

The product

Users in the EU, Switzerland and Norway

Our Products contain high quality components and are designed to facilitate recycling. Our products or product packaging are marked with the symbol below.



The symbol indicates that the product must not be treated as municipal waste. It must be disposed of separately via the appropriate return and collection systems available. By following these instructions you ensure that this product is treated correctly and help to reduce potential impacts on the environment and human health, which could otherwise result from inappropriate handling. Recycling of products helps to conserve natural resources and protect the environment.

For more detailed information on collection and recycling systems for this product, please contact the shop where you purchased it, your local dealer or sales/service representatives.

All Other Users

If you wish to discard this product, please contact your local authorities, the shop where you bought this product, your local dealer or sales/service representatives.

Software use license

CAREFULLY READ ALL THE TERMS AND CONDITIONS OF THE PRESENT LICENSE BEFORE OPENING THE SEALED ENVELOPE CONTAINING THE SOFTWARE. OPENING THIS ENVELOPE INDICATES THAT YOU ACCEPT THESE TERMS AND CONDITIONS.

In case you should not accept the terms of this license, the CD-ROM packaging should be returned to the retailer unopened, along with the other components of the product.

Definition

The Software designates programs and associated documentation.

License

- This license allows you to use this Software on personal computers on a local network. You only have permission to use this Software to print on one multifunction machine; you can not lend the Software or authorize anyone to use it.
- You are allowed to make a back up copy.
- This license is non-exclusive and non-transferable.

Property

The manufacturer or its providers hold the Software property right. You only become the owner of the CD-ROM. You shall not modify, adapt, decompile, translate, create any derived piece, rent or sell the Software or the documentation. Any rights not explicitly approved are reserved by the manufacturer or its providers.

Duration

This license remains valid until cancelled. You can cancel it by destroying the program and the documentation as well as any other copies of them. This license will automatically be canceled in case you do not respect the terms of this license. If the license is rendered invalid, you agree to destroy all copies of the program and the associate documentation.

Warranty

The Software is provided "as is" with no warranties what so ever, whether expressed or implied, including without limitation, any warranties of merchantability or fitness for a particular purpose; all the risks concerning the results and performance of this Software are assumed by the buyer. In case the program should appear defective, all the repair and service expenses will be covered by the buyer.

Nevertheless, the license holder benefits from the following warranty: we guarantee that the CD-ROM on which the Software is recorded is free from hardware or manufacturing faults if used in normal conditions, the guarantee is valid for ninety (90) days from the delivery date, the copy of the receipt being the proof of purchase. In case of a CD-ROM fault that due to accident or misuse, the CD-ROM will not be replaced as per the warranty.

Responsibility

If the CD-ROM is not working properly, send it to the retailer together with a copy of the receipt. It is the retailer's sole responsibility to replace the CD-ROM. Nobody, not even the manufacturer who is involved in the creation, realization, merchantability and delivery of this program would be responsible for direct, indirect or immaterial damages, such as, but not limited to, loss of information, loss of time, execution loss, loss of revenue, loss of customers, due to the use or inability to use the program.

Development

With a constant concern for improvement, the manufacturer reserves the right to modify the Software specifications without any notice. In case of modification, your user right does not give you access to free updates.

Registered trademarks

Companion Suite Pro is a registered trademark of Sagem Communications.

Adobe® and the Adobe® products referred to here are registered trademarks of Adobe Systems Incorporated.

PaperPort11SE is a registered trademark of ScanSoft.

Microsoft® Windows 2000®, Microsoft® Windows Server 2003®, Microsoft® Windows XP®, Microsoft® Windows Vista® and any other Microsoft® product referred to here are registered trademarks of Microsoft Corporation registered and/or used in the United States and/or in other countries.

All the other brands or products referred to as examples or in order to give additional information are registered trademarks of their respective owners.

The screenshots presented in this User's Guide have been created with Windows Vista. If you use another operating system, the screenshots displayed may be different from the ones presented in this booklet.

Notice

Do not copy or print any item for which reproduction is prohibited by law.

Copying or printing the following items is generally prohibited by local law: bank notes, revenue stamps, bonds, stock certificates, bank drafts, checks, passports, driver's licenses.

The preceding list is meant as a guide only and is not inclusive. We assume no responsibility for its completeness or accuracy.

If you have any questions concerning the legality of copying or printing certain items, consult with your legal advisor.

The informations contents of this user manual are subject to change without notice.

Installation

Location conditions

By choosing an appropriate location, you preserve the longevity of the machine. Check that the selected location has the following characteristics:

- Choose a well ventilated location.
- Make sure not to obstruct the ventilation grids located on the left and right sides of the device. During the installation, make sure to place the machine thirty centimeters away from the surrounding objects so all the lids can be easily opened.
- Make sure that this location does not present any ammonia nor any other organic gasses emission hazard.
- The ground outlet (refer to the security notices presented in the **Security** chapter) to which you plan to connect the machine shall be located close to this one and have an easy access.
- **Make sure that the machine is not directly exposed to sun light.**
- Make sure not to place the machine in an area exposed to an air flow generated by an air conditioning, heating or ventilation system, nor in an area subject to big temperature or humidity jumps.
- Choose a solid and horizontal surface on which the machine will not be exposed to intense vibrations.
- **Keep the machine away from any object that could obstruct its ventilation ports.**
- Do not place the machine close to hangings or any other flammable objects.
- Choose a location where the water and other splashes of liquid are limited.
- Make sure that this location is dry, clean and dust free.

Cautions of use

Take into account the important precautions below when using the machine.

Running environment:

- Temperature: 10 °C to 27 °C [50 °F to 80.6 °F] with an ambient humidity included between 15 to 80% (up to 32°C [89.6 °F] with an ambient humidity included between 15 to 54%).

Terminal:

The section below describes the precautions to be taken when using the machine:

- Never turn the machine off and never open the lids while printing.
- Never use gas or flammable liquids, or objects generating magnetic field close to the machine.
- When you unplug the power cord, always hold the connector without pulling the cord. A damaged cord presents a potential fire hazard or an electric shock hazard.
- Never touch the power cord with wet hands. You risk getting an electric shock.
- Always unplug the power cord before moving the machine. Otherwise, you could risk having the cord damaged and create a fire hazard or an electric shock hazard.
- Always unplug the power cord when you plan not to use the machine for a long period of time.
- Never put objects on the power cord, never pull it and never fold it. This could cause a fire hazard or an electric shock hazard.
- Always make sure that the machine is not sitting on the power cord or any other electric device communication cables. Make sure also that neither cord nor cable is introduced to the machine inner mechanism. This would expose you to a machine malfunction risk or to a fire hazard.
- Make sure that the printer is unplugged from the power outlet before connecting or disconnecting an interface cable to the printer (use a shielded interface cable).
- Never try to remove any fixed pane or hood. The machine contains high voltage circuits. Any contact with these circuits can cause an electric shock risk.
- Never try to modify the machine. This could cause a fire hazard or an electric shock hazard.
- Always make sure that paper clips, staples or other small metallic items do not get inside the machine via the ventilation ports or other ports. Such items create fire hazards or electric shock hazards.
- Prevent water and any other liquid from spilling on the machine or near to it. Any contact of the machine with water or liquid can cause a fire hazard or an electric shock hazard.

- If liquid or metallic item gets accidentally inside the machine, turn it off immediately, unplug the power cord and contact your retailer. Otherwise, you would face a fire hazard or an electric shock hazard.
- In case of heat, smoke, unusual smell or abnormal noise emissions, turn the machine off, unplug the power cord immediately and contact your retailer. Otherwise, you would face a fire hazard or an electric shock hazard.
- Avoid using the machine during an "electric storm", this can cause an electric shock hazard due to lightning.

Paper for printing: if you use paper already printed by your machine or another printer, the printing quality may not be optimal.



CAUTION Make sure to place the machine in well ventilated premises. When operating, the printer generates a small amount of ozone. An unpleasant smell can come from the printer if it is used intensively in not well ventilated premises. For a secure use, make sure you place the machine in well ventilated premises.

Safety information

When using your product, the following safety precautions should always be followed.

Safety During Operation

In this information slip, the following important symbols are used:

WARNING:	Indicates a potentially hazardous situation which, if instructions are not followed, could result in death or serious injury.
CAUTION:	Indicates a potentially hazardous situation which, if instructions are not followed, may result in minor or moderate injury or damage to property.



WARNING

- Connect the power cord directly into a wall outlet and never use an extension cord.
- Disconnect the power plug (by pulling the plug, not the cable) if the power cable or plug becomes frayed or otherwise damaged.
- To avoid hazardous electric shock or laser radiation exposure, do not remove any covers or screws other than those specified in the User's Guide.
- Turn off the power and disconnect the power plug (by pulling the plug, not the cable) if any of the following conditions exists:
 - You spill something into the product.
 - You suspect that your product needs service or repair.
 - Your product's cover has been damaged.
- Do not incinerate spilled toner or used toner. Toner dust might ignite when exposed to an open flame.
- Disposal can take place at our authorized dealer or at appropriate collection sites.
- Dispose of the used toner cartridge (or bottle) in accordance with the local regulation.



CAUTION

- Protect the product from dampness or wet weather, such as rain, snow, and so on.
- Unplug the power cord from the wall outlet before you move the product. While moving the product, you should take care that the power cord will not be damaged under the product.
- When you disconnect the power plug from the wall outlet, always pull the plug (not the cable).
- Do not allow paper clips, staples, or other small metallic objects to fall inside the product.
- Keep toner (used or unused), toner cartridge (or bottle), ink (used or unused) or ink cartridge out of reach of children.
- Be careful not to cut yourself on any sharp edges when you reach inside the product to remove misfed sheets of paper or masters.

- For environmental reasons, do not dispose of the product or expended supply wastes at household waste collection point. Disposal can take place at our authorized dealer or at appropriate collection sites.
- Our products are engineered to meet the high standards of quality and functionality, and we recommend that you only use the expendable supplies available at an authorized dealer.

Power Supply

The socket-outlet shall be installed near the product and shall be easily accessible.

For Fax or Telephone

- Do not use this product near water, for example near bath tub, wash bowl, kitchen sink or laundry tub, in a wet basement or near a swimming pool.
- Avoid using a telephone (other than a cordless type) during an electrical storm. There may be a remote risk of an electric shock from lightning.
- Do not use a telephone in the vicinity of a gas leak to report the leak.

Rules for use symbols



WARNING

Indicates important safety notes.

Ignoring these notes could result in serious injury or death. Be sure to read these notes. They can be found in the "Safety Information" section of this manual.



CAUTION

Indicates important safety notes.

Ignoring these notes could result in moderate or minor injury, or damage to the machine or to property. Be sure to read these notes. They can be found in the "Safety Information" section of this manual.



Important

Indicates points to pay attention to when using the machine, and explanations

of likely causes of paper misfeeds, damage to originals, or loss of data. Be sure to read these explanations.



Note

Indicates supplementary explanations of the machine's functions, and instructions on resolving user errors.

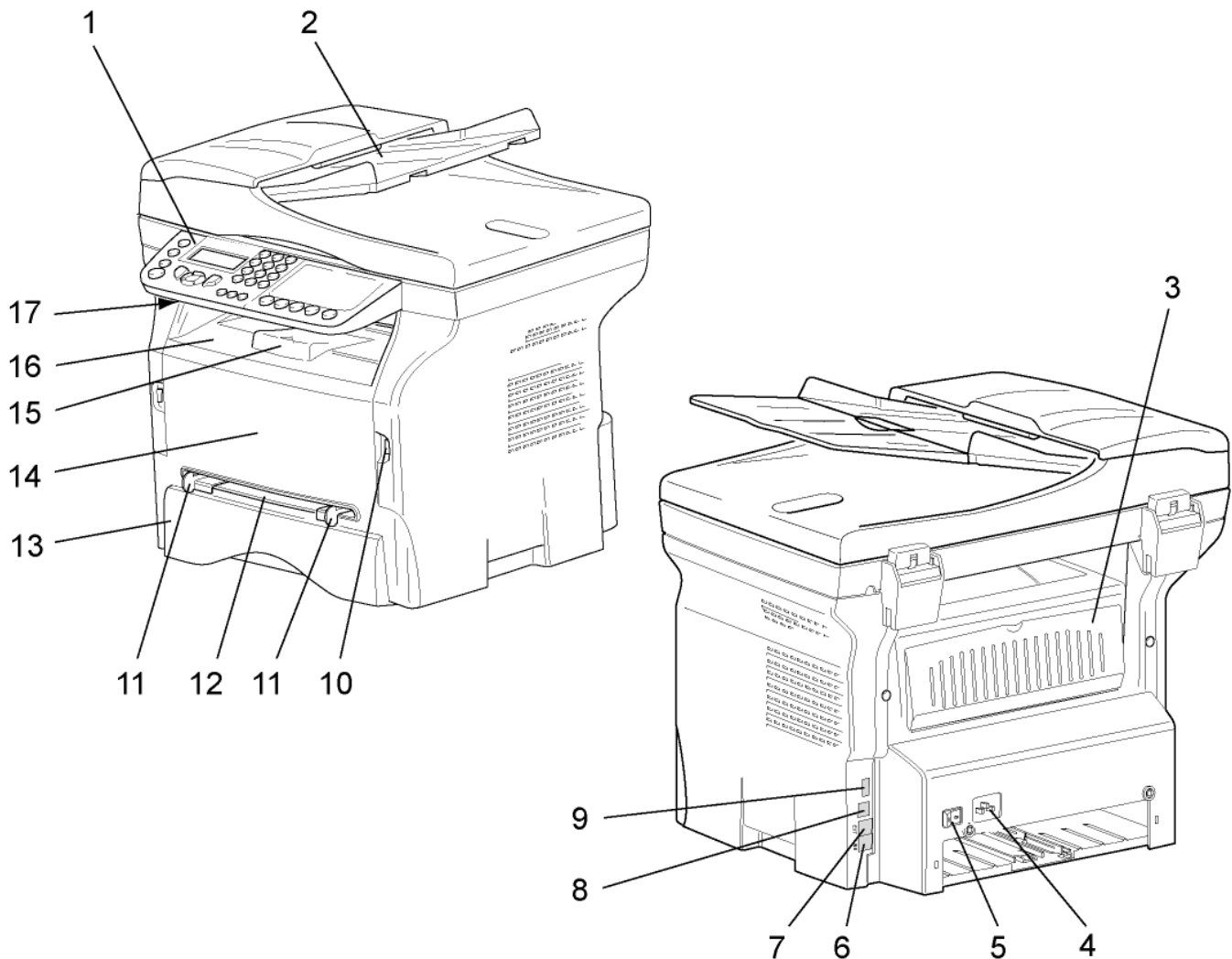







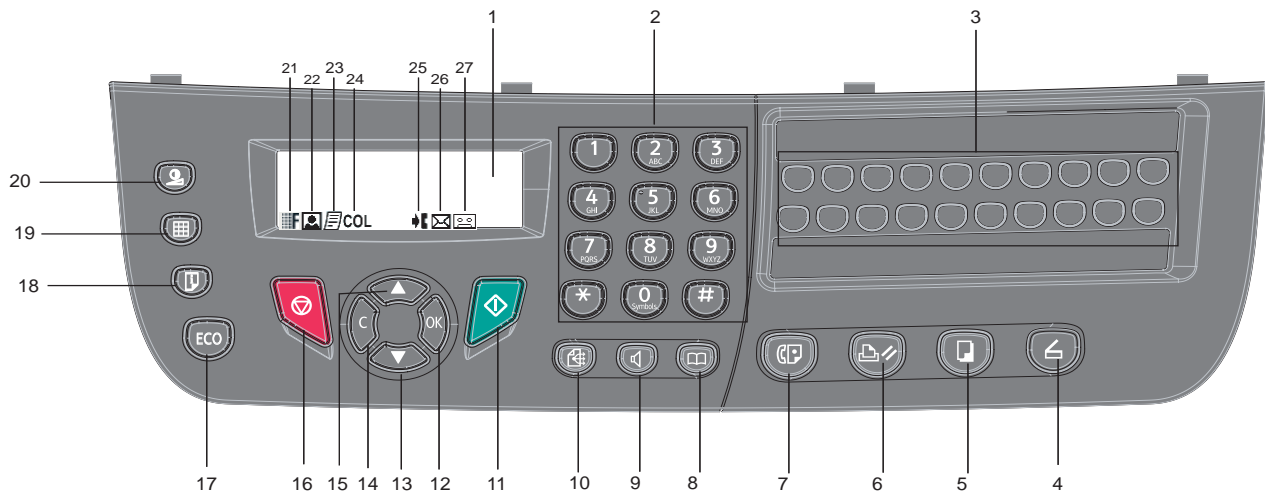











Terminal description**Front and Back sides**

- | | | | |
|----|---|-----|--------------------------------------|
| 1 | Control panel | 10. | Master USB connection (USB key) |
| 2. | Document feeder | 11. | Manual paper feed setup guides |
| 3. | Paper jam cover | 12. | Manual input tray |
| 4. | Power supply cord connection | 13. | Paper tray |
| 5. | On/Off switch | 14. | Cartridge access cover |
| 6. | LINE socket - telephone cable connection | 15. | Fold-down stopper for paper delivery |
| 7. | EXT. socket - connection for external telephone devices | 16. | Paper output |
| 8. | Slave USB connection (for PC) | 17. | Smart card insertion point |
| 9. | Master USB connection (USB key) | | |

Command panel

Presentation







1. Screen.
2. Alphanumerical keypad.
3. One-Touch keypad (buttons 1 to 20).
4. Button  : document analysis to the PC or a media (USB key).
5. Button  : local copy.
6. Button  : stops the current PC printing.
7. Button  : sending a fax.
8. Button  : access to directory and quick dial numbers.
9. Button  : line manual connection, listen for tone during fax sending.
10. Button  : multiple contact sending (fax).
11. Button  : Validation.
12. Button **OK**: confirms the displayed selection.
13. Button  : menu access and navigation down the menus.
14. Button **C**: back to the previous menu and input correction.
15. Button  : navigation up the menus.
16. Button  : stops the current operation.
17. Button  : sets up the activation delay and toner save in copy mode.
18. Button  : print menu (print functions list, machine settings, etc.).
19. Button  : analysis resolution setup.
20. Button  : contrast setup.
21. Icon  : resolution "Copy : **Quality text** / Fax : **Sfine**".
22. Icon  : resolution "**Photo**".
23. Icon  : resolution "Copy : **Text** / Fax : **Fine**".
24. Icon **COL** : color mode.
25. Icon  : activity on the telephone line.
26. Icon  : Fax mode.
27. Icon : external answering device mode

Entering Characters Using the Alphanumerical keypad

As you perform various tasks, you need to enter names and numbers. For example, when you set up your machine, you enter your name (or your company's name) and telephone number. When you store one-, two-, or three-digit speed dial or group dial numbers, you may also enter the corresponding names.













To enter alphanumeric characters when you are prompted to enter a letter, locate the button labeled with the character you want. Press the button until the correct letter appears on the display.

Examples :

- to enter the name "**John**", press :  1 time,  6 times,  5 times and  5 times.
- to enter "!", press :  17 times.

If you make a mistake while entering a number or name, press the **C** button to delete the last digit or character. Then enter the correct number or character.

The following table gives all available characters.

Key	Assigned numbers, letters, or characters	Key	Assigned numbers, letters, or characters
	1		P, Q, R, S, p, q, r, s, 7
	A, B, C, a, b, c, 2		T, U, V, t, u, v, 8
	D, E, F, d, e, f, 3		W, X, Y, Z, w, x, y, z, 9
	G, H, I, g, h, i, 4		Space 0 @ . + - / & \$ %
	J, K, L, j, k, l, 5		# _ , ; : ? () [] < > { } ~ = ! ' " \ €
	M, N, O, m, n, o, 6		*

Accessing terminal functions

All terminal functions and settings are available via the menu and are associated to a specific menu command. For example, **CONTRAST** copy settings are identified in the menu with the command **845**.

Two methods are available to access menu items : a step by step method or a shortcut method.

To access the **CONTRAST** settings with the Step by step method :

- 1 Press on ▼ to access the menu.
- 2 Use the ▼ or ▲ buttons to browse the menu and select **8-ADVANCED FCT**. Confirm with **OK**.
- 3 Use the ▼ or ▲ buttons to browse the **ADVANCED FUNCTIONS** menu and select **84-COPY**. Confirm with **OK**.
- 4 Use the ▼ or ▲ buttons to browse the **COPY** menu and select **845-CONTRAST**. Confirm with **OK**.

To access the **CONTRAST** settings with the shortcut method :

- 1 Press on ▼ to access the menu.
- 2 Enter 845 with the alphanumerical keypad to directly access the **CONTRAST** item.

Packaging contents

The packaging contains the items listed below:

Multifunction device

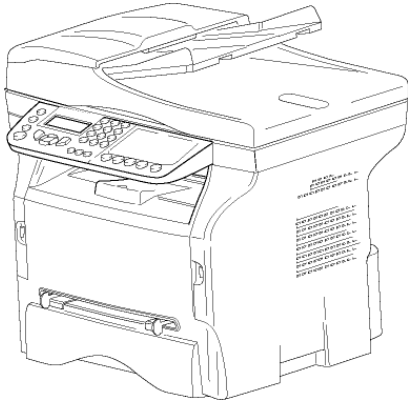

1 toner cartridge

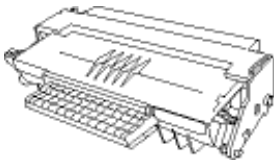

1 installation guide and 1 PC installation CD ROM

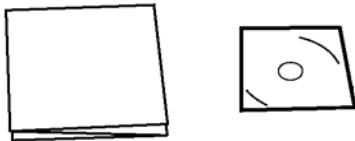

1 Safety Guide, Command Guide (For Europe and North America only)



1 power cord



1 line cord



1 USB cord



Device installation

- 1 Unpack the device.
- 2 Install the device respecting the security notices stated at the beginning of this booklet.
- 3 Remove all stickers from the machine.
- 4 Remove the plastic protection film from the screen.

Installing the document feeder

- 1 Secure the document feeder by fitting the two clips (B) in the notches (A) provided for this purpose.

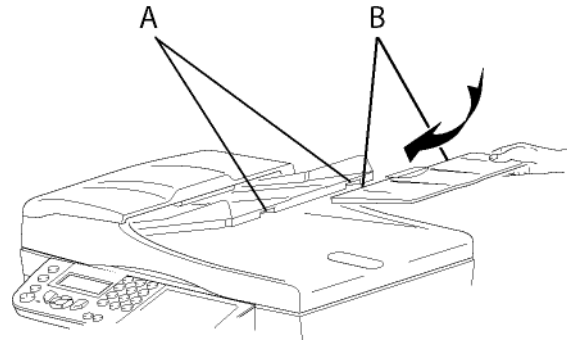

Loading paper

Loading paper in the paper Tray

- (1) Paper to be used must be inserted face down, and abutting the side fence and back fence. Not abutting the paper may cause feed failure, skewing or paper jams.
- (2) Amount of loaded paper must not exceed the loading mark. If the loading mark is exceeded, this may cause feed failure, skewing, or paper jams.
- (3) Adding paper to the pile may cause double feeding, and should be avoided.
- (4) When withdrawing the cassette from the main unit, always hold it with both hands.

Handling of paper

- (1) Curling must be corrected before loading.
- (2) Curls must not exceed 10 mm.
- (3) Care must be taken with storage to prevent feed faults and image defects due to leaving the paper in conditions of high humidity.
Adding paper to the pile, or splitting the pile may cause feeding problems, and must be avoided.

Humidity control

- (1) Paper which has become damp, or paper which has been left unused for a very long time, must not be used.
- (2) After opening the paper, it must be kept in a plastic bag.
- (3) Paper with waved ends, paper which is creased, paper with crumples, and any other non-normal paper must not be used.

Handling the unit

Operator shocks

During printing, shocks must not be applied to the paper feed cassette, tray, cover, and other parts of the machine.

Moving the unit

When moving the unit on a desk, it must be lifted, and not dragged.

Handling the Toner Cartridge

- (1) Must not be stood on the side, or held upside down.
- (2) Must not be shaken strongly.

Feed cassette paper insertion

Your device accepts a number of formats and types of papers.



Important

See chapter Specifications for the various formats and types of paper.

- 1 Remove the paper feed cassette completely.

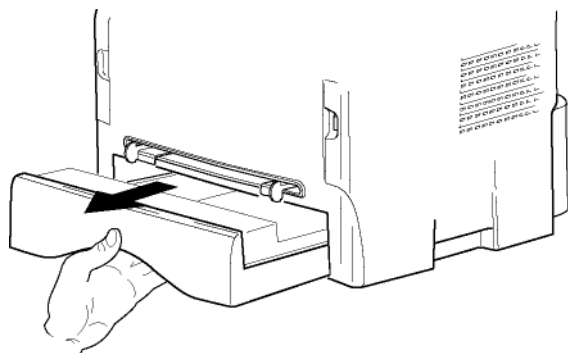

- 2 Push the lower panel down until it clicks.

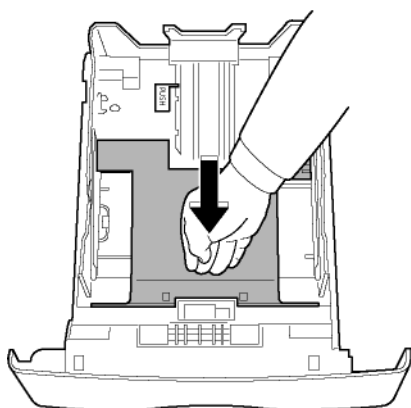

- 3 Setup the back side feed cassette stop by pushing the "PUSH" lever (A). Then adjust the lateral paper guides to the paper format by pushing lever (B) located on the left guide. Adjust the length paper guide to the paper format by pushing lever (C).

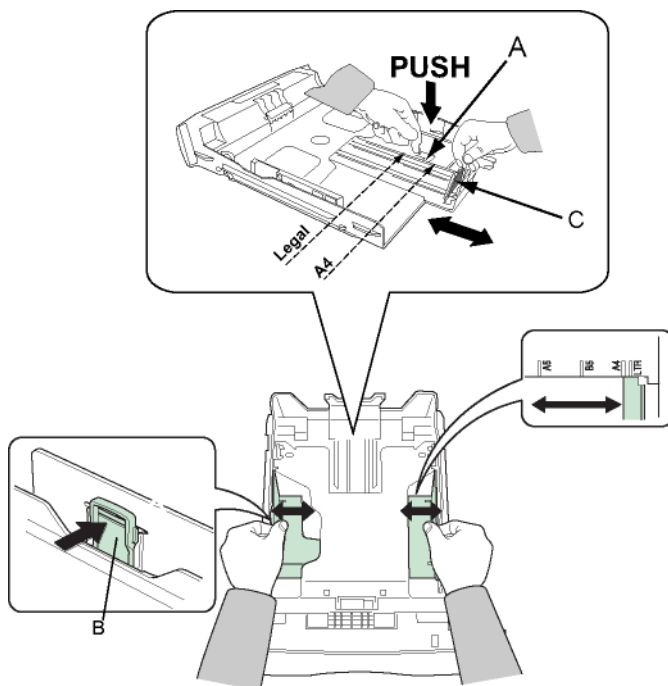

- 4 Take a paper stack, pull the paper off and align it on a flat surface.

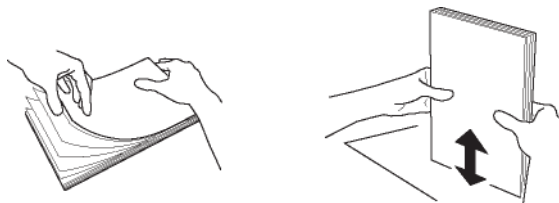

- 5 Put the paper stack in the feed cassette (200 sheets for 80 g/m² paper for instance).
- 6 Put the feed cassette back in its location.

Cartridge installation

- 1 Stand in front of the machine.
- 2 Push the left and right sides of the cover and pull it at the same time towards you.

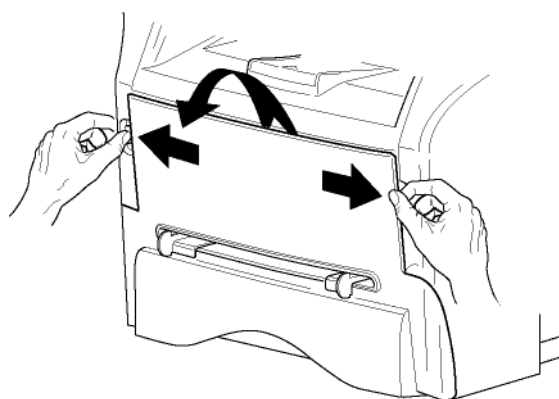

- 3 Remove the starter toner cartridge from its bag. Gently roll the cartridge 5 or 6 times to distribute the toner evenly inside the cartridge. Thoroughly rolling the cartridge will assure the maximum copies per cartridge.

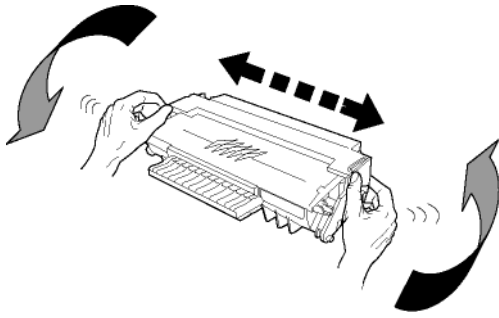

- 4 Hold it by its handle.
5 Insert the cartridge in its slot by pushing it until it clicks (last move down) as shown on the picture below.

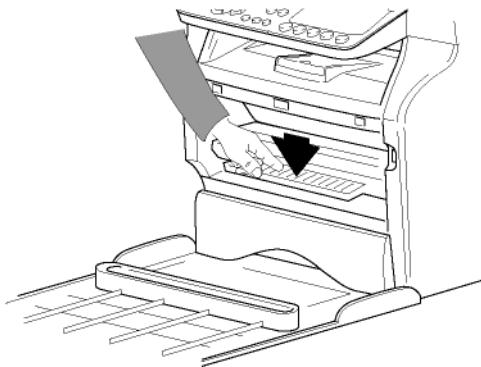
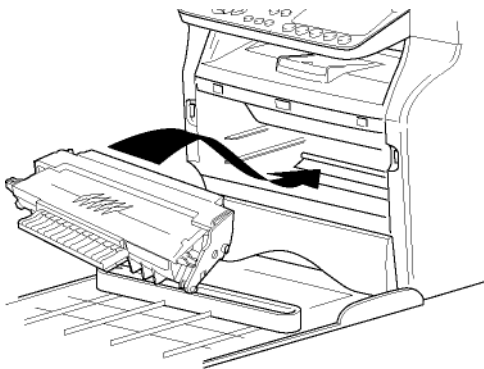

- 6 Close the cover.

Paper delivery stop

Adjust the paper delivery stop, depending on the format of the document to be printed. Do not forget to raise the flap to prevent the sheets from falling down.

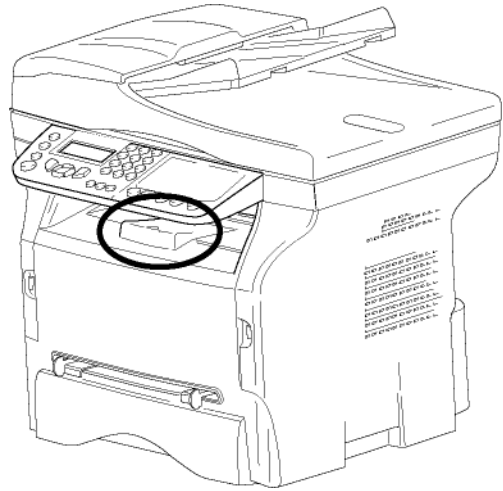

Starting your device

Device connection



WARNING

Before plugging the power cord, it is imperative to refer to the **Security directives**, page 1.

- 1 Plug the end of the telephone line into the terminal socket and the other end into the wall telephone socket.

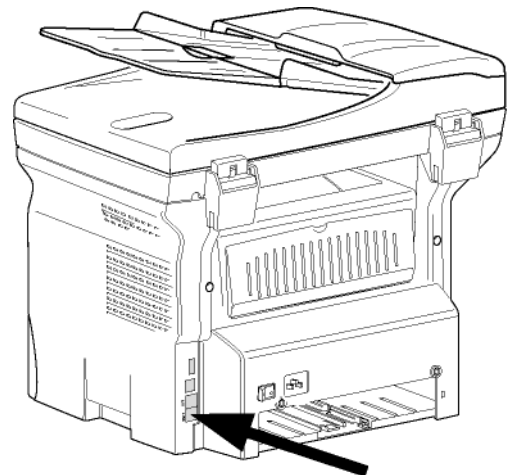

- 2 Connect the power cord to the device.

- 3 Make sure that the On/Off switch is off (O position). Plug the power cord to outlet on the wall.

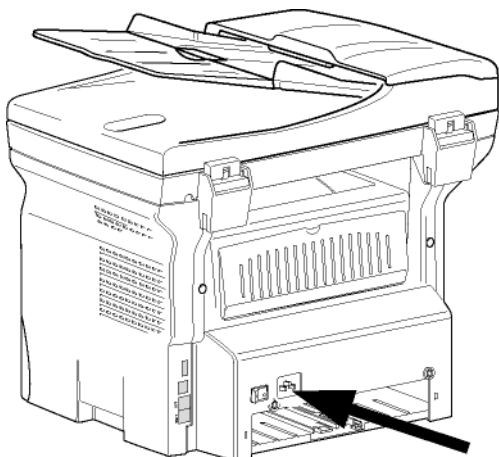

WARNING

The power cord is used as a 230 V power unit cut off. As a precaution, the outlet shall be located close to the device and be of easy access in case of danger.

- 4 Press the On/Off button to turn on the device (I position).

Device initial setup

After a few seconds, when the machine has warmed up, the **Easy Install** function is launched and the LCD screen displays the following message:



1 - FRANCAIS
2 - ENGLISH

The **Easy Install** function will help you configure your machine by guiding you through the basic settings.

If you wish to modify the setting displayed, press the **OK** button. If you do not want to modify the displayed setting, press the **C** button: the **Easy Install** function then displays the next basic setting.



Note

If you do not want to carry out the initial setup, press the  button. A confirmation message appears. Press the  button again to confirm. To manually modify and customise the machine settings, refer to **Parameters/Setup, page 28.**

- 1 Select the desired language using the ▲ or ▼ buttons and confirm with **OK**.
- 2 To set the country, press the **OK** button.

SET COUNTRY
YES=OK - NO=C

- 3 Select your country in the list displayed using the ▲ or ▼ buttons and confirm with **OK**.



Note

If none of the options in the list is suitable, select the "OTHER" option.

- 4 If you have set the country to "Other", you may need to set the public telephone NETWORK to use. Press the **OK** button to specify it.

SET NETWORK
YES=OK - NO=C

Select the telephone network to use in the list displayed using the ▲ or ▼ buttons and confirm with **OK**.



Important

If none of the options in the list is suitable, select the "OTHER X" option:

- OTHER 1 = TRB21
- OTHER 2 = US
- OTHER 3 = Russia
- OTHER 4 = Jordan
- OTHER 5 = Israel
- OTHER 6 = TRB21

- 5 To set the date and time, press the **OK** button.

DATE/TIME
YES=OK - NO=C

- 6 Enter the numbers of the required date and time one after another using the numerical keypad. The date format depends on the country you have selected: for instance, DDMMYY for France, MMDDYY for the USA. Use the **C** button to correct an entry. Press **OK** to confirm.

- 7 To specify the fax number and machine name, press the **OK** button. This information will appear on your transmitted documents when the "Sending Header (TX HEADER)" function is activated.

NAME/NUMBER
YES=OK - NO=C

- 8 Enter your fax number (20 digits max.) using the numerical keypad. To type the "+" sign press the  button until it appears on the screen. Use the **C** button to correct an entry. Press the **OK** button to confirm.
- 9 Enter your machine name (20 characters max.) using the alphanumerical keypad. Press the **OK** button to confirm.

- 10 If you are connecting your machine to a private network, behind a company's PABX, you may need to specify a local prefix. This prefix will be then used to exit the company's telephone network. To set up this function, press the **OK** button.

PREFIX
YES=OK - NO=C

- 11** Enter the minimal size of the company's outside numbers (1 to 30) using the numerical keypad. This setting is used to differentiate internal telephone numbers from external telephone numbers.

For example, if you are installing the machine in France, behind your company's PABX, enter 10 (10 digits being the standard telephone number length for France).

Use **C** to correct an entry.

Press the **OK** button to confirm.

- 12** Enter the local prefix number (10 characters max.) using the numerical keypad.

This prefix will automatically be added when an external number is dialled.

To insert a pause for dial tone ("/"sign), long press the 0 (zero) key on the numerical keypad until the "/" sign is displayed.

Use the **C** button to correct an entry.

Press the **OK** button to confirm.

Note: When using envelopes

- Feeding can be done only through the manual feed.
- Recommended area should be the area which excludes 15 mm from the leading edge, 10 mm from and both the left and right edges, and the rear edge.
- Envelopes which are not recommended may lead to improper printing.
- Curled envelope after printing should be fixed manually.
- Small crumples on the edge of the wide side of envelopes. Smearing, or less clear printing may appear on the reverse side.
- Set envelope by pressing the folding line of four edges properly after releasing air inside.
- Set envelope in a proper position after aligning in case it is bent or warped.
- Paper conditioning is not allowed. And it should be used under normal office environment.

The setup is now complete and the functions list is automatically printed out.

The LCD screen displays the message **PAPER EMPTY** if no paper has been loaded in the paper tray (see **Loading paper**, page 14). Once paper has been loaded, printing will resume.

Paper insertion in the manual input tray

The manual input tray allows you to use various paper formats with greater weightings than the one used in the paper feed cassette.

Only one sheet or envelope can be fed at a time.



Important

See chapter Specifications for the various formats and types of paper.

- 1 Spread the manual feed guides to the maximum.

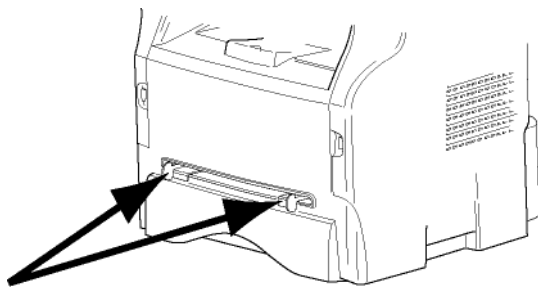

- 2 Insert a sheet or an envelope in the manual input tray.
- 3 Adjust the paper guides against the right and left edges of the sheet or the envelope.
- 4 Print making sure that the chosen paper format corresponds to the selected format on the printer.

Copy

Your machine has the function to make one or more copies.

You can also setup several parameters in order to make copies at your will.

Simple copy



In this case, the default parameters are applied.

- 1 Place the document to be copied in the automatic document feeder, face printed on the top.
or
Place the document to be copied face down on the glass, respecting the indications around the glass.
- 2 Press the  button twice. The copy is made using the default parameters.

ECO mode copy

The ECO mode enables you to reduce the amount of toner consumed on the page so as to save your printing costs.

When the ECO mode is used, the toner consumption is reduced and the print density becomes lighter.

- 1 Place the document to be copied in the automatic document feeder, printed face on the top.
or
Place the document to be copied face down on the glass, respecting the indications around the glass.
- 2 Press the  button.
- 3 Press the  button.

Sophisticated copy

The sophisticated copy allows to do custom setups for the current copy.



Note

You can start copy by pressing  button at any time in below steps.

- 1 Place the document to be copied in the automatic document feeder, face printed on the top.
or
Place the document to be copied face down on the glass, respecting the indications around the glass.



Note

After step 1, you can directly enter the number of copies with the numerical keypad and press the OK button to validate. Then refer to step 4.

- 2 Press the  button.
- 3 Enter the number of copies that you want and confirm with the **OK** button.
- 4 Choose the paper tray **AUTOMATIC** or **MANUAL** with the buttons \blacktriangledown or \blacktriangle , then confirm with the **OK** button.
- 5 Choose with the buttons \blacktriangle or \blacktriangledown the printing option (see examples below) depending on the copy mode that you want:
- Mosaic mode (document feeder): **1 Page onto 1**, **2 Pages onto 1**, or **4 Pages onto 1**.

MOSAIC Copy mode

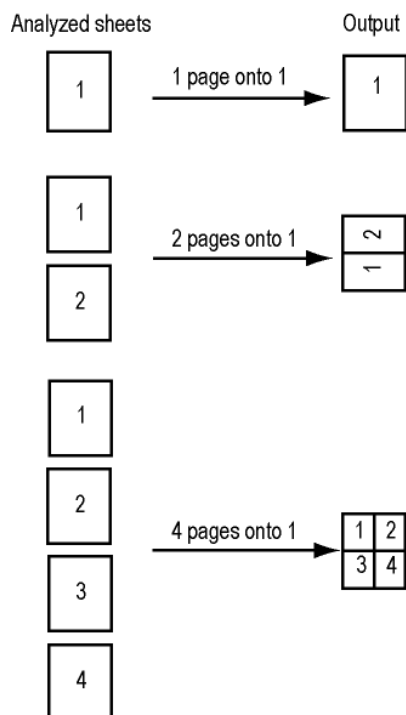

- Poster mode (flat-bed scanner): **1 Page to 1**, **1 Page to 4** or **1 page to 9**.

POSTER Copy mode

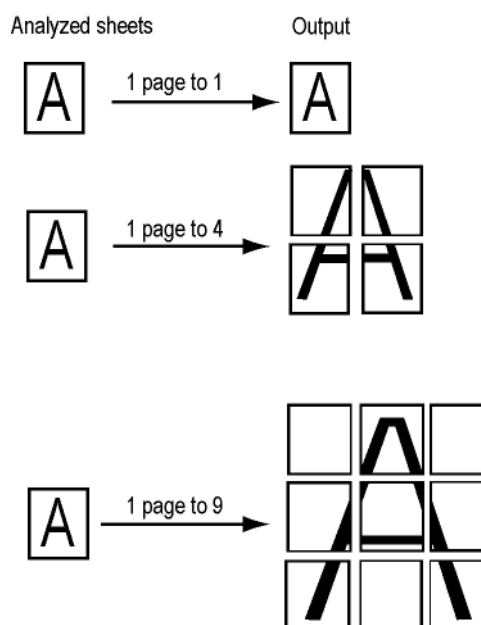

Confirm with the **OK** button.

- 6 Adjust the desired zoom level, from **25% TO 400%** with the buttons **▼** or **▲**, confirm with the **OK** button (only available in **1 Page to 1** copy mode).
- 7 Adjust the desired origin values with the digital keyboard buttons **▼** or **▲** then confirm with the **OK** button.
- 8 Choose the resolution depending on the printing quality that you want **AUTO**, **TEXT**, **QUALITY TEXT** or **PHOTO** with the buttons **▼** or **▲**, then confirm with the **OK** button.
- 9 Adjust the contrast level with the buttons **▼** or **▲**, then confirm with the **OK** button.
- 10 Adjust the desired brightness level with the buttons **▼** or **▲**, then confirm with the **OK** button.
- 11 Choose the paper type **NORMAL**, **THICK** with the buttons **▼** or **▲**, then confirm with the **OK** button.

- 7 Adjust the contrast level with the buttons **▲** or **▼**, then confirm with the **OK** button.
- 8 Adjust the desired brightness level with the buttons **▲** or **▼**, then confirm with the **OK** button.
- 9 Choose the paper type **NORMAL**, **THICK** with the buttons **▲** or **▼**, then confirm with the **OK** button. The LCD screen displays the following message:

**PUT ID CARD
THEN OK**

- 10 Place your identity card or any other official document against the glass of the flatbed scanner, as shown below:

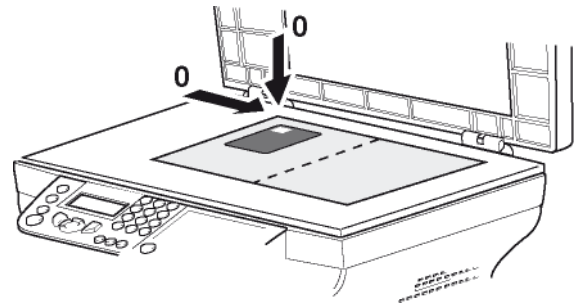

- 11 Press the **OK** button. The document is scanned then the LCD screen displays the following message:

**TURN UP DOC
THEN OK**

- 12 Turn your document over then confirm with the **OK** button.

The machine prints out a copy of your document.

Special setup for the copy

Setups done through this menu become the device **default setups** after you confirm.



Important

When the quality of the printing is not satisfying, you can proceed to a calibration with **MENU 80**.

Resolution setup

The **RESOLUTION** parameter allows you to setup the photocopy resolution.

▼ **841 - ADVANCED FCT/COPY/RESOLUTION**

- 1 Choose the resolution with the buttons **▼** or **▲** according to the following table:

Parameter	Signification	Icon
AUTO	Low resolution.	none
TEXT	Standard resolution for documents containing text and graphics.	

ID Card Copy mode

The ID CARD copy function is used for copying both sides of an identity card or driver's license type document on an A4 format sheet (original document size < A5) or on a Letter format sheet (original document size < Statement).

The LCD screen displays useful operating instructions (when the original document should be placed, when the document should be turned over, etc.) and asks for your confirmation to proceed with the operation.



Important

This function is available only if the document to be copied is placed on the flatbed scanner, and if no paper is detected in the automatic document feeder. Zoom and Origin adjustments are not available in this copy mode.

- 1 Make sure that there is no document in the automatic document feeder.
- 2 Press the button.
- 3 Enter the desired number of copies and confirm with the **OK** button.
- 4 Choose the paper tray **AUTOMATIC** or **MANUAL** with the buttons **▲** or **▼**, then confirm with the **OK** button.



Important

Copying in ID Card mode is only possible on A4 (original document size < A5) or Letter (original document size < Statement) paper size. Make sure that the selected paper tray uses the correct paper size.

- 5 Choose the copying option **ID CARD** with the buttons **▲** or **▼** and confirm with the **OK** button.
- 6 Choose the resolution depending on the desired printing quality **AUTO**, **TEXT**, **QUALITY TEXT** or **PHOTO** with the buttons **▲** or **▼**, then confirm with the **OK** button. For optimal results with ID documents, select the **PHOTO** resolution.

Parameter	Signification	Icon
QUALITY TEXT	Optimal resolution for documents containing text.	
PHOTO	Optimal resolution for documents containing photographs.	

- 2 Confirm your choice by pressing the **OK** button.



Note You can also make temporary changes to the resolution by pressing the button.

Zoom setup

The **ZOOM** parameter allows you to reduce or enlarge an area of a document by choosing the origin and the zoom level to apply to the document, from 25 to 400 %.

▼ 842 - ADVANCED FCT/COPY/ZOOMING

- 1 Enter the desired zoom level with the Alphanumeric keyboard or choose among predefined values with the buttons 5 and 6.
- 2 Confirm your choice by pressing the **OK** button.

Analysis origin setup

If you want, you can change the origin of the scanner.

By entering new values for X and Y in mm ($X < 210$ and $Y < 280$), you move the analysed area as shown on the diagram below.

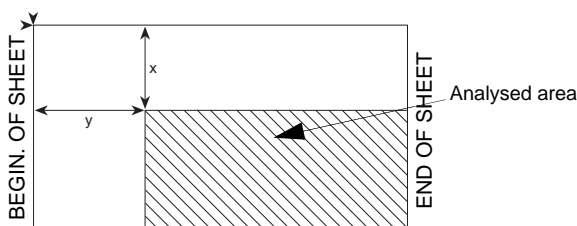

▼ 844 - ADVANCED FCT/COPY/ORIGIN

- 1 Select the X and Y coordinates with the buttons ▼ or ▲.
- 2 Setup the desired coordinates with the digital keyboard or the buttons ▼ and ▲, confirm your choice by pressing on the **OK** button.

Contrast setup

The **CONTRAST** parameter allows to choose the photocopy contrast.

▼ 845 - ADVANCED FCT/COPY/CONTRAST

- 1 Setup the desired level of contrast with the buttons ▼ and ▲, confirm by pressing the **OK** button.

- 2 You can also directly setup the desired contrast with the button, press several times on this button until the desired setup without using the Menu 845.

- 3 Quit this menu by pressing the button.

Brightness setup

The **BRIGHTNESS** parameter allows to lighten or darken your original document.

▼ 846 - ADVANCED FCT/COPY/BRIGHTNESS

- 1 Setup the desired brightness with the buttons ▼ and ▲.
- 2 Confirm your choice by pressing the **OK** button.
- 3 Quit this menu by pressing the button.

Paper type setup

▼ 851 - ADVANCED FCT/SCAN. & PRINT/PAPER TYPE

- 1 Select the paper **NORMAL** or **THICK** that you use with the buttons ▼ and ▲.
- 2 Confirm your setup by pressing the **OK** button.
- 3 Quit this menu by pressing the button.

Paper tray selection

The **Automatic** selection can have two meanings depending on the paper format defined on the paper trays. The following table describes the different cases.

	Default tray	Tray used for copy
Same paper format in the trays	AUTOMATIC	Selection between the main tray and the manual tray.
	MANUAL	The manual tray is used.
Different paper format in the trays	AUTOMATIC	The main tray is used
	MANUAL	The manual tray is used.

▼ 852 - ADVANCED FCT/SCAN. & PRINT/TRAY PAPER

- 1 Select the default paper tray to use, **AUTOMATIC** or **MANUAL**, with the buttons ▼ and ▲.
- 2 Confirm by pressing the **OK** button.
- 3 Quit this menu by pressing the button.

Sheet-feed analysis margins setup

If you want to, you can offset the lateral margins of the document to the left or right during the analysis with your sheet-feed scanner.

▼ 853 - ADVANCED FCT/SCAN. & PRINT/ S.F. MARGINS

- 1 Setup the left / right margins offsets (by 0.5 mm steps) with the buttons ▼ and ▲.
- 2 Confirm by pressing the **OK** button.
- 3 Quit this menu by pressing the  button.

Flat-bed analysis margins setup

If you want to, you can offset the lateral margins of the document to the left or right during the analysis with your flat-bed scanner.

▼ 854 - ADVANCED FCT/SCAN. & PRINT/ FLATBED MARG

- 1 Setup the left / right margins offsets (by 0.5 mm steps) with the buttons ▼ and ▲.
- 2 Confirm by pressing the **OK** button.
- 3 Quit this menu by pressing the  button.

Left and right printing margins setup

If you want to, you can offset the lateral margins of the document to the left or right during printing.

▼ 855 - ADVANCED FCT/SCAN. & PRINT/ PRINTER MARG

- 1 Setup the left / right margins offsets (by 0.5 mm steps) with the buttons ▼ and ▲.
- 2 Confirm by pressing the **OK** button.
- 3 Quit this menu by pressing the  button.

Top and bottom printing margins setup

If you want to, you can offset the lateral margins of the document towards the top or the bottom during printing.

▼ 856 - ADVANCED FCT/SCAN. & PRINT/TOP PRINT.

- 1 Setup the top / bottom margins offsets (by 0.5 mm steps) with the buttons ▼ and ▲.
- 2 Confirm by pressing the **OK** button.
- 3 Quit this menu by pressing the  button.

Format paper setup

This menu allows you to define the default paper format of the manual tray and the main tray. You can also setup the default scanning width.

▼ 857 - ADVANCED FCT/SCAN. & PRINT/

PAPER FORMAT

- 1 Select the paper tray for which you want to define a default paper format with the buttons ▼ and ▲.
- 2 Confirm by pressing the **OK** button.
- 3 Choose the paper format with the buttons ▼ or ▲ according to the following table:.

Paper tray	Available paper format
MAN. TRAY	A5, A4, Legal and Letter
AUTO. TRAY	A5, A4, Legal and Letter
SCANNER	LTR/LGL and A4

- 4 Confirm by pressing the **OK** button.
- 5 Quit this menu by pressing the  button.

Fax

This chapter describes all the fax processing and configuration functions.

Fax transmission

Print a header page

A header page is stored in your terminal. To send your fax using this header page, you can print it at any time and fill in your details.

- 1 Select **▼ 30 - FAX /HEADER PAGE**.
- 2 Select:
 - 301 - LOCAL**, to print a header page according to the language configured on the terminal,
 - 302 - INTERNAT**, to print a bilingual header page, the language of the country configured on the terminal and English. The separator between the two languages is "/".



Note

If English is the language configured on the terminal, the header page will only be printed in English.



Example of the international header page:

FAX

A / TO :	FAX :
SE / FROM :	TELEPHONE :
DATE :	PAGES :

OBJET / SUBJECT

Immediate transmission

- 1 Place the document to be copied in the automatic document feeder, face printed on the top.
or
Place the document to be copied face down on the glass, respecting the indications around the glass.
- 2 Enter the fax number then press  or .
- 3 If you are using the flatbed scanner, you can scan more than one page. Place the next page on the scanner, select **NEXT** and confirm with **OK**. Select **DONE** when all pages have been scanned.

The  icon flashes during the call phase, it stays lit when both faxes are in communication.

At the end of transmission the initial screen is displayed



Note

*To change the dialling mode after entering the fax number, press **OK**.*

Delayed transmission

This function allows you to transmit a document at a later time.

To program a postponed transmission you need to identify the subscriber number, transmission time, feeder type and number of pages.

To delay the transmission time of your document :

- 1 Place the document to be copied in the automatic document feeder, face printed on the top.
or
Place the document to be copied face down on the glass, respecting the indications around the glass.



Important

Make sure that the document in the feeder tray or on the scanner window is properly located in order to avoid sending blank or incorrect pages.

- 2 Select **▼ 31 -FAX / TRANSMISSION**.
- 3 Enter the subscriber number you wish to program at a different time or choose your dialling mode and confirm with **OK**.
- 4 Next to the current time, enter the new time and confirm with **OK**.
- 5 Choose **B&W SCAN** or **COLOUR SCAN**.
- 6 Adjust the contrast and confirm with **OK**.
- 7 Select the feed type, **FEEDER** or **MEMORY** and confirm with **OK**.
- 8 You may enter the number of pages before transmission and confirm with **OK**.
- 9 Confirm postponed transmission by pressing .
- 10 If you are using the flatbed scanner, you can scan more than one page. Place the next page on the scanner, select **NEXT** and confirm with **OK**. Select **DONE** when all pages have been scanned.

Your document is stored and will be sent at the new time.



Transmission with auto redial

This function allows you to monitor the dialling operation during a fax transmission. In this case, the maximum transmission rate will be 14400 bps.

This function allows for example:

- to hear if the subscriber's fax is engaged and if so, choose the moment when the line is clear to start the document transmission.
- to control the communication progress in case of uncertain numbers, etc.

To take the line manually:

- 1 Place the document in the fax feeder.
- 2 Press .
- 3 If necessary, set the sound level using the ▼ or ▲ keys.
- 4 Enter the subscriber number.
As soon as you hear the remote fax tone, the line is clear and you can start the transmission.
- 5 Press  to start the document transmission.

If your machine is set in order to print a transmission report, the reduced copy of the document first page will not be printed and it notifies you that the communication is manual (see **Transmission report**, page 30).

Fax reception

Fax reception depends on the parameter settings of your machine.

The following parameters let you customize the printing of received faxes :

- **Reception Mode**, page 30;
- **Reception without paper**, page 31;
- **Number of copies**, page 31;
- **Fax or PC reception**, page 31;
- **Received faxes reduction mode**, page 31;
- **Technical Parameters**, page 32.



Important *The printing is not possible on A5 paper format.*

The following tables gives which tray is used to print received fax depending on the default tray and the paper format in both trays.

Default tray set to **Manual** .:

Manual tray paper format	Main tray paper format	Action
A4,Letter and Legal	A4,Letter and Legal	The fax is printed on manual tray.
A4,Letter and Legal	A5	The fax is printed on manual tray.

Manual tray paper format	Main tray paper format	Action
A5	A4,Letter and Legal	The paper on manual tray is incompatible. The fax is printed on the main tray.
A5	A5	An error message is displayed on the screen. The paper on manual tray is incompatible.

Default tray set to **Automatic** .:

Manual tray paper format	Main tray paper format	Action
A4,Letter and Legal	A4,Letter and Legal	The fax is printed with an automatic selection of tray.
A4,Letter and Legal	A5	An error message is displayed on the screen. The paper on automatic tray is incompatible.
A5	A4,Letter and Legal	The fax is printed on the main tray.
A5	A5	An error message is displayed on the screen. The paper on automatic tray is incompatible.

Fax answering device

The Fax answering device allows you to keep confidential documents in storage and to avoid printing them as you receive them.

The  indicator light lets you know the state of your Fax answering device:

- Light on: the answering device is on.
- Blinking: your fax has documents in storage or is in the process of receiving faxes.
- Light off: memory full, the terminal cannot receive any more documents.
- You can assure document confidentiality by using the 4 digit access code. Once saved, you will require this access code for:
 - printing fax messages in memory,
 - activating or deactivating the fax answering device.

Saving an access code

▼ **383 - FAX / FAX ANSW. / ANSWER CODE**

- 1 Enter the code (4 digits) and confirm with **OK**.

Activating / Deactivating the answering device

▼ 382 - FAX / FAX ANSW. / ACTIVATION

- 1 If you saved an access code for your fax answering device, enter it and validate with **OK**.
- 2 Select the required option **WITH** or **WITHOUT** answering device and confirm your choice with **OK**.
- 3 Select the required answering machine option, **ON** or **OFF**, and confirm your choice with **OK**.

Printing fax messages stored in the memory



Important

The printing is not possible on A5 paper format.

▼ 381 - FAX / FAX ANSW. / PRINT

- 1 If you have defined an access code for your fax answering device, enter it and press **OK**.

Documents received and stored in the memory are printed.

Fax rerouting (Forwarding)

This function is used to reroute faxes received to a contact of directory. To use this function, you have to perform two operations:

- 1 Activate rerouting.
- 2 Set the rerouting address of the fax.

Activating rerouting



Make sure that the subscriber exists in the directory (Directory, page 35).

▼ 391 - FAX / REROUTING / ACTIVATION

- 1 Press on ▼, enter 391 with the keyboard.
- 2 Using the keys ▼ and ▲ within the navigator, select option **ON**.
- 3 Using the keys ▼ and ▲ within the navigator, select the subscriber from the directory.
- 4 Confirm with **OK**.

If the option OFF is selected, the menus 392 and 393 will not be included in the functions overview, when it is printed out.

Setting the re-direction contact

▼ 392 - FAX / REROUTING / CALL NUMBER

- 1 Using the buttons ▼ and ▲ within the navigator, select the subscriber from the directory.
- 2 Confirm with **OK**.
- 3 Quit this menu by pressing the  button.

Printing rerouted documents

▼ 393 - FAX / REROUTING / COPY

- 1 Using the buttons ▼ or ▲ within the navigator, select the **COPY** option (local printout of the information relayed to your device) either **ON** or **OFF**.
- 2 Confirm with **OK**.
- 3 Quit this menu by pressing the  button.

Rerouting fax messages to a USB memory key

This function allows you to reroute received fax messages directly in the folder MFPrinter Laser Pro LL2\FAX on a USB memory key connected to your terminal. The folder MFPrinter Laser Pro LL2\FAX is created by the application. The USB memory key then becomes the terminal reception memory.

Fax messages that are rerouted are therefore saved on the USB memory key with format Tiff and are named as follows : "FAXYYMMDDHHMMSS" where YYMMDDHHMMSS corresponds to the fax reception date and time.

You can also print fax messages rerouted to your USB memory key automatically by activating menu 052 PRINT.

Activating rerouting



Important

Before activating this function, connect the USB memory key to the terminal.

▼ 051 - MEDIA / FAX ARCHIVING / ACTIVATION

- 1 Using the keys ▼ and ▲ within the navigator, select option **ON** and confirm your choice with **OK**.
- 2 Quit this menu by pressing the  button.

Printing rerouted documents



Important

The printing is not possible on A5 paper format.



Important

This menu is only accessible when the function FAX ARCHIVING is activated.

▼ 052 - MEDIA / FAX ARCHIVING / PRINT

- 1 Using the keys ▼ and ▲, select the copy option **ON** to print all rerouted documents automatically.
- 2 Confirm your choice with **OK**.
- 3 Quit this menu by pressing the  button.

Transmission waiting queue

This function lets you obtain a recap of all documents queuing, for transmission, including those in deposit or in delayed transmission, etc.

It allows you to:

- **Consult** or **modify** the waiting queue. In this waiting queue the documents are coded the following way: Order number in the queue / document status / subscriber's telephone number.

Documents may have the following status:

- **TX**: transmission
- **DOC**: in deposit
- **POL**: polling
- **TR**: ongoing commands

Immediately perform a transmission from the waiting queue,

- **Print a document** in storage, waiting to be transmitted or in deposit,
- **Print the waiting queue**, in order to get the status of each document in the queue, by either:
 - queue order number,
 - document name or number,
 - scheduled transmission time (fax),
 - operation type regarding the document: transmission from memory, delayed transmission, deposit,
 - number of pages of the document,
 - document size (percentage of space stored in memory)
- **Cancel** a transmission request in the waiting queue.

Performing immediate transmission from the waiting queue

▼ 61 - COMMANDS / PERFORM

- 1 Select the document in the waiting queue and confirm your choice with **OK** or  to immediately perform the selected transmission.

Consulting or modifying the waiting queue

▼ 62 - COMMANDS / MODIFY

- 1 In the waiting queue select the required document and confirm your choice with **OK**.
- 2 You may now modify the parameters of the given document then confirm your modifications by pressing .

Deleting a transmission in memory

▼ 63 - COMMANDS / CANCEL

- 1 In the waiting queue select the desired document and confirm your choice with **OK**.

Printing a document in waiting or in deposit

▼ 64 - COMMANDS / PRINT

- 1 In the waiting queue select the desired document and confirm your choice with **OK**.

Printing the waiting queue

▼ 65 - COMMANDS / PRINT LIST



A document called ** COMMAND LIST ** is printed.

Cancelling a transmission in progress

Cancelling a transmission in progress is possible whatever the type of transmission but varies depending on whether the transmission is a single call number or a multi-call number.

- For a single call number from the memory, the document is erased from the memory.
- For a multi-call number, only the call number in progress at the time of the cancellation is erased from the transmission queue.

To cancel transmission in progress:

- 1 Press . A message will ask you to confirm cancellation.
- 2 Press  to confirm cancellation in progress.

If your machine is set to print a transmission report, it will print that the communication was cancelled by the user.

Deposit and Polling

You may **deposit** a document in your fax and keep it available to one or more subscribers who can obtain a fax of this document by calling your fax with the **POLL** function.

Setting the machine for document deposits, you must define the type:

- **SIMPLE**- it may be polled only once from the memory or feeder,
- **MULTIPLE**- it may be polled as many times as necessary from the memory.

Setting the machine for polled documents, you must define the poll number, then depending on the type of poll you may:

- launch an immediate poll,
- program a delayed poll with a chosen time,
- launch a multi-poll, either immediately or later.

Placing a document in deposit

- 1 Insert the document to deposit in the feeder.
- 2 Select ▼ 34 - FAX / POLLING TX and confirm with **OK**.
- 3 Choose the deposit type, according to the table below:



Menu	Procedure
Simple	<ol style="list-style-type: none"> 1 Select FEEDER or MEMORY. 2 If necessary, adjust the contrast and confirm with OK. 3 Enter the number of pages that you wish to deposit.
Multiple	<ol style="list-style-type: none"> 1 If necessary, adjust the contrast and confirm with OK. 2 Enter the number of pages that you wish to deposit.

- 3 Confirm deposit by pressing **OK**.

Polling a deposited document

▼ 33 - FAX / POLLING RX

- 1 Enter the number of the party whose document you want to poll or choose your dialling mode. You can poll several documents using the button .
- 2 Depending on the type of poll, you should:

Menu	Procedure
Immediate poll	<ol style="list-style-type: none"> 1 Press .
Delayed poll	<ol style="list-style-type: none"> 1 Press OK. 2 Next to the current time, enter the time you wish to poll the document and press .

Parameters/ Setup

You can setup your machine as you like depending on the use. You will find in this chapter description of the functions.

You can print the functions guide and the available setup of your multifunction machine.



Note

Your machine is continuously being updated, new functions are regularly made available.

Contact your Dealer to check if firmware updates are available for your machine (see **Firmware update**, page 65).

Date/Time

At any moment you may change the date and time on your multifunction machine.

Depending on the country configured on the machine, the date format is of type DDMMYY (e.g.: France) or MMDDYY (e.g.: USA).

▼ 21 - SETUP / DATE/TIME

- 1 Press ▼, enter **21** using the keypad. Confirm with **OK**.
- 2 Enter the numbers of the required time and date one after another (for example November 8 2004 at 9h33, press 0811040933 or 1108040933) and press **OK** to confirm.

- 3 To exit this menu, press .

Summer time / Winter time setting

This menu lets you choose to change to summer / winter time automatically or not.



Important

This function is only available if the country configured on the machine is part of the European Union.

The **21>DATE/TIME** menu includes 2 submenus:

Manual mode

▼ 211 - SETUP / DATE/TIME / MODIFY

Your multifunction machine will prompt you to change the date and time via the numerical keypad.

Automatic mode

▼ 212 - SETUP / DATE/TIME / AUTO ADJUST

If you select **OFF** and confirm with **OK**, the summer / winter time will not be changed automatically. For the machine to be set to the new time, you will need to use the **211 MODIFY** menu.

If you select **ON** and confirm with **OK**, you will not have to care about any change at the end of March (+1h) and October (-1h). You will just be informed of this change by a message on the screen.

The default parameter is **OFF**.

Warning message

On automatic changing to summer / winter time, a message will be displayed to inform you that the multifunction machine time has been changed.

25-03-07 02:01
CHECK TIME

or

28-10-07 02:01
CHECK TIME

Your next action on the multifunction keypad will cause the message to be automatically cleared.

Your fax number/Your name

Your multifunction machine will print out your fax number and your name on each document it transmits if you save these settings.

To save your fax number and your name:

▼ 22 - SETUP / NUMBER/NAME

- 1 Press ▼, enter **22** using the keypad. Confirm with **OK**.
- 2 Enter your fax number (20 digits max.) and press **OK** to confirm.
- 3 Enter your name (20 characters max) then press **OK** to confirm.

For example, if you want to type the letter C, press the button **C** until it appears on the screen.

- 4 To exit this menu, press .



Important

To benefit from this feature, you must set SENDING HEADER (TX HEADER) to ON.

Type of network

You may connect your fax to either a PSTN or private network such as private automatic branch exchange (PABX). You must select the network which is the most convenient.

To select the type of network:

▼ 251 - SETUP / TEL. NETWORK / NETWORK TYPE

- 1 Press ▼, enter **251** using the keypad. Confirm with **OK**.
- 2 Select option **PABX** or **PSTN** then confirm your choice with **OK**.

If you are connecting your machine to a private network, behind a company's PABX, you may need to specify a local prefix (see **Local prefix**).

Geographical settings

These settings will enable you to use your machine in different preset countries using different languages.

Country

By choosing a country, you initialise:

- the settings for the public telephone network,
- the language by default.

To select the country:

▼ 201 - SETUP / GEOGRAPHICAL / COUNTRY

- 1 Press ▼, enter **201** using the keypad. Confirm with **OK**.
- 2 Select the required option and press the **OK** button to confirm.



Important

If none of the options in the list is suitable, select the "OTHER" option.

Telecommunication Network

This setting enables you to manually set the type of public telephone network (PSTN) for a country, so that your machine can communicate over the public telephone network in compliance with the applicable standards.

By default, setting a country using the ▼ 201 command automatically sets the type of PSTN to use in the selected country.



Important

*These settings are different from the **NETWORK TYPE**, which allows you to choose between public and private network.*

To manually select the type of public telephone network:

▼ 202 - SETUP / GEOGRAPHICAL / NETWORK

- 1 Press ▼, enter **202** using the keypad. Confirm with **OK**.
- 2 Select the required option and press the **OK** button to confirm.

If none of the options in the list is suitable, select the "OTHER X" option:

- OTHER 1 = TRB21
- OTHER 2 = US
- OTHER 3 = Russia
- OTHER 4 = Jordan
- OTHER 5 = Israel
- OTHER 6 = TRB21



Important

Language

This setting enables you to choose the menu language of your choice. By default, the multifunction machine is set to English.

To select the language:

▼ 203 - SETUP / GEOGRAPHICAL / LANGUAGE

- 1 Press ▼, enter **203** using the keypad. Confirm with **OK**.
- 2 Select the required language using ▼ and ▲, then press the **OK** button to confirm.
- 3 To exit this menu, press .

Local prefix

This function is used when your fax is installed with a private network, behind a company's PABX. It allows you to program an additional automatic **local prefix** (to be defined), enabling you to automatically exit the company's telephone network system, but only under certain conditions:

- the company's internal numbers, where a prefix is not required, must be short numbers less than the **minimal size** (to be defined, for example France has 10 digits),
- the outside numbers requiring a prefix, must be long numbers greater or equal to the **minimal size** (to be defined, for example France has 10 digits).

Programming your fax with the local prefix consists of two steps:

- 1 defining the **minimal size** (or equal) of the company's outside numbers,
- 2 defining the outgoing **local prefix** of the company's telephone network. This prefix will automatically be added as soon as an external number is dialled.

**Important**

If you define a local prefix, do not add it to the numbers stored in the directory, it will be automatically dialled with each number.

▼ 252 - SETUP / TEL. NETWORK / PREFIX

- 1 Enter the required minimal **SIZE NUMBER** of the company's outside numbers and confirm with **OK**. The minimal size will range between 1 and 30.
- 2 Enter the required outgoing local **PREFIX** of the company's telephone network (maximum 10 characters) and confirm with **OK**.

**Note**

To insert a pause for dial tone ("/" sign), long press the 0 (zero) key on the numerical keypad until the "/" sign is displayed.

Transmission report

You may print a **transmission report** for all communications over the telephone network (STN). You may choose between more than one criteria for printing reports:

- **ON**: a report is given when the transmission was properly performed or when it is completely abandoned (but there is only one report per request),
- **OFF**: no transmission report, however, your fax will note all transmissions that took place in its log,
- **ALWAYS**: a report is printed with each transmission,
- **ON ERROR**: a report is printed only if the transmission failed or is abandoned.

With each transmission report from memory, a reduced version of the first page is automatically reproduced. To select the report type:

▼ 231 - SETUP / SEND / SEND REPORT

- 1 Select the required option **ON**, **OFF**, **ALWAYS** or **ON ERROR** and confirm your choice with **OK**.

Document feed type

You may choose the way you want to feed your documents:

- from **memory**, transmission will take place only after memory storage of the document and dialling. It allows you to get your originals back quickly to free up the machine.
- from the **feeder** of the sheet-feed scanner, transmission will occur after dialling and paper scanning. It allows transmission of larger documents.

To select the way you want to feed your documents:

▼ 232 - SETUP / SEND / MEMORY SEND.

- 1 Select the option **MEMORY** or **FEEDER** and validate your choice with **OK**.

In feeder mode, reduced images will not appear on the transmission report.

Economy period

This function allows you to defer a fax transmission to "off-peak hours" and thus reduce the cost of your communications.

The **economy period**, via the telephone network (at off-peak hours), is preset by default from 7.00 pm to 7.30 am. Nevertheless you may change this time slot.

To modify the economy period:

▼ 233 - SETUP / SEND / ECO PER.

- 1 Enter the hours of the new economy period (for example 19:00-07:30) and confirm your choice with **OK**.

To use the economy period:

▼ 32 - FAX / ECO TRANS.

- 1 Enter the call number and confirm with **OK**.
- 2 Choose **B&W SCAN** or **COLOUR SCAN** and confirm with **OK**.
- 3 Adjust the contrast and confirm with **OK**.
- 4 Select the feed type, **FEEDER** or **MEMORY** and confirm with **OK**.
- 5 You may enter the number of pages before transmission and confirm with **OK**.
- 6 If you are using the flatbed scanner, you can scan more than one page. Place the next page on the scanner, select **NEXT** and confirm with **OK**. Select **DONE** when all pages have been scanned.

Reception Mode

This function enables you, if you have an external device (telephone, answering machine) plugged in to the EXT socket on your terminal or to the telephone plug adapter, to select the device receiving faxes and/or voice messages.

You may choose between the following reception modes :

- **MANUAL** : the terminal does not receive any documents automatically. When you answer your telephone and realise that you are receiving a fax, you should press the  button on the terminal to receive the fax.
- **FAX** : the Fax reception mode is launched on the terminal systematically.

- **FAX-ANSW.** : the terminal handles reception of fax messages automatically, the external device handles reception of telephone communications automatically. Press the #0 buttons on your telephone to cancel fax detection.

To set the reception mode:

▼ 241 - SETUP / RECEPTION / MODE

- 1 Select the required option and confirm with **OK**.
- 2 To exit this menu, press .

If you have connected a telephone to the EXT socket on your terminal or to a telephone plug adaptor, we recommend that you set the reception mode to MANUAL.



Important When you receive a call, you pick up using this telephone and you hear the particular fax tone. You can:

- press the  button on your terminal or buttons #7 on your telephone to receive the fax

Reception without paper

Your fax offers you the possibility to either accept or refuse document reception if your printer is unavailable (no paper...).

If your fax printer is unavailable, you may choose between two modes of reception:

- reception mode **WITHOUT PAPER**, your fax saves the incoming messages in the memory,
- reception mode **WITH PAPER**, your fax refuses all incoming subscribers.

To select the reception mode:

▼ 242 - SETUP / RECEPTION / REC. PAPER

- 1 Select the option **WITH PAPER** or **WITHOUT PAPER** and confirm your choice with **OK**.

Paper out is indicated by a beep and a message on the screen.

Received faxes are then stored in memory (icon  flashing) to be printed as soon as you add paper into the feeder.



Important

Number of copies

You may print incoming documents more than once (1 to 99).

To set the number of each document received:

▼ 243 - SETUP / RECEPTION / NBR OF COPIES

- 1 Enter the wanted number of copies and confirm with **OK**.

At each document reception, your fax will print the number of copies requested.

Fax or PC reception

This menu, combined with a software program installed on your PC will enable you to select the machine you wish to receive the documents on:

- fax,
- PC,
- PC if available, fax otherwise.

▼ 244 - SETUP / RECEPTION / PC RECEPT.

For more details, please refer to **Fax communications**, page 52 in chapter PC Features.

Adjust to page

This menu allows you to print out received faxes automatically adjusting them to the page format. Received faxes are then automatically reduced or enlarged to fit the page format which is used on the machine.

To turn adjust to page mode on:

▼ 245 - SETUP / RECEPTION / AUTO ADJUST.

- 1 Press ▼, enter **245** using the keypad.
- 2 Select the option **ON** or **OFF** and confirm with **OK**.
- 3 To exit this menu, press .

Received faxes reduction mode

This menu allows you to reduce received faxes for printing. This adjustment can be automatic or manual.

Automatic mode

This mode automatically resizes received faxes.

To set automatic mode :

▼ 246 - SETUP / RECEPTION / REDUCTION

- 1 Select **Automatic** and confirm with **OK**.
- 2 To exit this menu, press .

Manual mode :

The machine proposes a 70 to 100 % reduction. Outside these values, the machine beeps for error. This fixed reduction will be used when printing received documents, regardless of the used paper format.

To set the manual mode :

▼ **246 - SETUP / RECEPTION / REDUCTION**

- 1 Select **FIXED** and confirm with **OK**.
- 2 Enter the reduction value (between 70 and 100) and confirm with **OK**.
- 3 To exit this menu, press .

Technical Parameters

As delivered your machine is preset by default. However, you may adjust it to meet your requirements by resetting the technical parameters.

To set the technical parameters:

▼ **29 - SETUP / TECHNICALS**

- 1 Select the desired parameter and confirm with **OK**.
- 2 With the buttons ▼ or ▲, modify the parameter settings by following the table below and press **OK**.

Parameter	Signification
1 - Scanning mode	Default value of the scan mode resolution for the documents to be transmitted.
2 - TX header	If this parameter is on, your header will appear on all documents sent to your subscribers with your name, number, date and number of pages. Warning: If you send a fax from the document loader, the transmission header will not appear on the document your correspondent receives.
3 - TX speed	Transmission speed for outgoing documents. For a quality telephone line (compatible, no echo), communications occur at maximum speed. However, it may be necessary to restrict the transmission speed for some calls.
4 - Echo protect	If this parameter is on, the on-line echo will be reduced during long distance calls.
6 - EPT mode	For some long distance calls (satellite), the on-line echo may disturb the call.

Parameter	Signification
7 - COM. display	Choice between transmission speed displayed or number of the page in progress.
8 - Eco energy	Choosing the printer standby delay: the printer will switch to standby after a delay (in minutes) of NON-operation or during the period of time of your choice. Note: you can also access this parameter by pressing the  key from the idle screen.
10 - RX header	If this parameter is on, all documents received by your fax will include the subscriber's header with his name, number (if available) fax print date and the page number.
11 - RX speed	Transmission speed for incoming documents. For a quality telephone line (compatible, no echo), communications occur at maximum speed. However, it may be necessary to restrict the transmission speed for some calls.
12 - Rings	Number of rings to automatically start your machine.
13 - Discard size	The Discard Size parameter only defines the printing of received faxes . The number of lines of a document can be too high for the printing paper format. This parameter defines the threshold beyond which the extra lines are printed on a second page. Below this threshold, extras lines are deleted. If you choose ON , the threshold is set on 3 centimeters. If you choose OFF , the threshold is set on 1 centimeter.
20 - E.C.M.	This parameter helps correct the calls made on disturbed telephone lines. It is used when the lines are weak or too noisy. Transmission times may be longer.
25 - TEL Impedance	This parameter lets you choose between a complex impedance and a 600 Ohm impedance, depending on the telephone network your terminal is connected to.

Parameter	Signification
79 - Toner Management	This parameter helps you manage the consumable. When set to WITH [0-100%], you can only replace the toner cartridge when the toner has reached the threshold. If ever you need to replace the toner cartridge before the toner near end, set the parameter to WITH [0-100%] and proceed with the toner cartridge replacement (see chapter Maintenance , page 60). Disabling the toner management (parameter set to WITHOUT) is strongly not recommended as you may lose faxes and spill toner in your print mechanism. When set to WITHOUT , the screen displays TONER ? % .
80 - Toner save	Makes printing lighter to save toner cartridge ink.
91 - Printer error timeout	Time-out before document being printed is deleted following a print error in PC print mode.
92 - Printer wait timeout	Wait time-out for data from PC before the task is deleted in PC print.
93 - Replace format	Page format change. This parameter allows you to print a LETTER format document on A4 pages using the LETTER/A4 setting.

- incoming or outgoing results: noted **CORRECT** if properly transmitted,
or
information codes for special calls (polling, manual subscribers, etc.)
- reason for call error (example: your subscriber does not answer)

To print the logs:

▼ **54 - PRINT / LOGS**

- Press on ▼ and enter **52** with the digital keypad. The printing of the logs starts.

The incoming and outgoing logs are printed on the same page.

Print the list of setups



Important *The printing is not possible on A5 paper format.*

To print the list of setups:

▼ **56 - PRINT / SETUP**

Press ▼, enter **56** using the keypad.

The printing of the list of setups starts.



Note *You can also access the list of setups by pressing the  button directly.*

Printing the functions list



Important *The printing is not possible on A5 paper format.*

▼ **51 - PRINT / FUNCTIONS LIST**

- Press on ▼ and enter **51** with the digital keypad. The printing of the functions guide starts.

Printing the logs



Important *The printing is not possible on A5 paper format.*

*The incoming and outgoing logs list the last 30 transmissions (incoming and outgoing) made by your machine.
An automatic print out will take place after every 30 transmissions. However, you may request a print out at any time.*

Each log (incoming or outgoing) contains a table with the following information:

- date and time of the incoming or outgoing document,
- subscriber's number,
- transmission mode (**Normal**, **Fine**, **SFine** or **Photo**),
- number of pages sent or received,
- call duration,

Lock the machine

This function prevents non-authorized people from accessing the machine. An access code will be required every time someone wants to use the device. After each use, the device will lock automatically.

Before that you have to enter a lock code.

▼ **811 - ADVANCED FCT / LOCK / LOCKING CODE**

- Press on ▼, enter **811** with the digital keyboard.
- Enter your lock code (4 digits) with the keyboard, confirm with **OK**.







Important *If a code is already registered, enter the old code before typing the new one.*

- Enter again your lock code (4 digits) with the keyboard, confirm with **OK**.
- Quit this menu by pressing the  button.

Lock the keyboard

Everytime you use your machine, you will have to enter your code.

▼ **812 - ADVANCED FCT / LOCK / LOCK KEYBD.**



- 1 Press on , enter **812** with the keyboard.
- 2 Enter the lock code and confirm with **OK**.
- 3 With the buttons  or , choose **ON** and confirm with **OK**.
- 4 Quit this menu by pressing the  button.

Lock the numbers

This function locks dialling and the numerical keypad is disabled. Transmissions are only possible from numbers included in the directory.

To access the number interlocking option:

▼ 813 - ADVANCED FCT / LOCK / LOCK NUMBER

- 1 Enter the four-digit interlock code with the keypad.
- 2 Press button **OK** to confirm.
- 3 With buttons  or , select the option **ONLY DIRECT**.
- 4 Press button **OK** to confirm.





Lock the Media service

This function prevents access to the Media service. The access code will be required every time someone wants to use the USB key functions:

- analyse the contents of a connected USB key,
- print from a USB key, delete files,
- archive received faxes on a USB key.

To access the Media service locking menu:

▼ 816 - ADVANCED FCT / LOCK / LOCK MEDIA

- 1 Press , enter **816** using the keypad.
- 2 Enter the four-digit locking code with the keypad.
- 3 Press **OK** to confirm.
- 4 With the buttons  or , choose **ON** and confirm with **OK**.
- 5 Quit this menu by pressing the  button.

Read the counters

This function allows you to view the activity counters for your machine at any time.



According to your needs, you can read the counters for:

- sent pages,
- received pages,
- scanned pages,
- printed pages.

Sent pages counter

To view the number of pages sent from your machine:



▼ 821 - ADVANCED FCT / COUNTERS / SENT PAGES

- 1 Press on , enter **821** with the keyboard.
- 2 The number of sent pages appears on the screen.
- 3 Quit this menu by pressing the  button.

Received pages counter

To view the number of pages received on your machine:



▼ 822 - ADVANCED FCT / COUNTERS / RECEIVED PG

- 1 Press on , enter **822** with the keyboard.
- 2 The number of received pages appears on the screen.
- 3 Quit this menu by pressing the  button.

Scanned pages counter

To view the number of pages scanned on your machine:



▼ 823 - ADVANCED FCT / COUNTERS / SCANNED PAGE

- 1 Press on , enter **823** with the keyboard.
- 2 The number of scanned pages appears on the screen.
- 3 Quit this menu by pressing the  button.

Printed pages counter

To view the number of pages printed on your machine:



▼ 824 - ADVANCED FCT / COUNTERS / PRINTED PG

- 1 Press on , enter **824** with the keyboard.
- 2 The number of printed pages appears on the screen.
- 3 Quit this menu by pressing the  button.

Display the consumables status

You can read at any time the remaining toner in the cartridge. This level appears in percentage.

▼ 86 - ADVANCED FCT / CONSUMABLES

- 1 Press on , enter **86** with the keyboard.
- 2 The available toner percentage appears on the screen.
- 3 Quit this menu by pressing the  button.

Calibrate your scanner

You can do this operation when the quality of photocopied documents is not satisfactory anymore.

▼ 80 - ADVANCED FCT / CALIBRATION

- 1 Press on , enter **80** with the keyboard, confirm with **OK**.
- 2 The scanner is triggered and a calibration is done automatically.
- 3 At the end of the calibration, the machine comes back to the screen saver.

Directory

Your multifunction machine lets you create a directory by memorising subscriber records and subscriber lists. Your machine can store up to 250 speed dials, which includes 32 Group dials and 20 one-touch dials.

For all 250 Speed dials or group dials you may create, consult, modify or delete contents. You can also print the directory.

Furthermore, your machine lets you create and manage your phone directory from your PC Kit. For more information on this feature, refer to chapter PC Features.

Creating Speed dial

To create Speed dial:

▼ 11 - DIRECTORY / NEW CONTACT

- 1 Press on ▼, enter **11** with the alphanumerical keypad.
- 2 Enter the **NAME** of your contact with the alphanumerical keypad (20 characters maximum), confirm with **OK**. To enter the characters, refer to section **Entering Characters Using the Alphanumerical keypad**, page 12.
- 3 Enter the **TEL** number of your contact with the alphanumerical keypad (30 digits maximum), confirm with **OK**.
- 4 Choose the **RECORD NO (SPEED DIAL No)** from your directory with the alphanumerical keypad or accept the displayed number, and confirm with **OK**.
- 5 Select **W.ONE-TOUCH** if you want to assign a One-Touch button to your speed dial as a shortcut. The first available One-Touch button appears, use ▼ or ▲ to choose another One-Touch button. Confirm with **OK**.
- 6 Select the appropriate transmission **RATE** to send faxes among the values 2400, 4800, 7200, 9600, 12000, 14400 and 33600 using ▼ or ▲. Confirm with **OK**.
The maximum speed can be used if the telephone line is of good quality, meaning appropriate, without echo.



Important

If your multifunction machine is connected to a PABX, you may insert a pause for dial tone after the outgoing local prefix dialling. To do so, "/" should be set after the local prefix by pressing "0" for few seconds.

For more details, refer to **Local prefix**, page 29.

Creating Group dial

To create group dial:

▼ 12 - DIRECTORY / NEW GROUP

- 1 Press on ▼, enter **12** with the alphanumerical keypad.
- 2 Enter the **GROUP NAME** with the alphanumerical keypad (20 characters maximum), confirm with **OK**.
- 3 **CALLED NUMBER**: use ▼ or ▲ to select from existing records the contacts of your group dial or directly press the One-Touch button associated to the contact and confirm with **OK**. Repeat this operation for each subscriber you want to add to your group dial.
- 4 Enter the **GROUP NUMBER** assigned to your group dial with the alphanumerical keypad or accept the displayed number, and confirm with **OK**.
- 5 Select **W.ONE-TOUCH** if you want to assign a One-Touch button to your group dial as a shortcut. The first available One-Touch button appears, use ▼ or ▲ to choose another One-Touch button. Confirm with **OK**.



Important

In the directory, the letter **G** placed next to a name identifies a subscribers group.

Modifying a record

To modify a speed or group dial:

▼ 13 - DIRECTORY / MODIFY

- 1 Press on ▼, enter **13** with the alphanumerical keypad.
- 2 With ▼ or ▲, browse the directory and select the speed or group dial you want to modify by pressing **OK**.
- 3 With ▼ or ▲, browse the entries of the selected speed or group dial. Press on **OK** when the entry you want to modify appears on screen.
- 4 The cursor appears at the end of the line. Press on **C** to delete characters.
- 5 Enter the new entry and confirm with **OK**.
- 6 Repeat the operations for each line you want to modify.

Deleting a record

To delete a speed or group dial:

▼ 14 - DIRECTORY / CANCEL

- 1 Press on ▼, enter **14** with the alphanumerical keypad.
- 2 With ▼ or ▲, browse the directory and select the speed or group dial you want to delete by pressing **OK**.
- 3 Press on **OK** to confirm the deletion.
- 4 Repeat the operations for each speed or group dial you want to delete.

Printing the directory



Important

The printing is not possible on A5 paper format.

To print the directory:

▼ 15 - DIRECTORY / PRINT

- 1 Press on ▼, enter **15** with the alphanumerical keypad.

The printing of the directory starts, alphabetically ordering directory entries in the following three categories:

- Directory (speed and groups dial list),
- Group dial list,
- One-Touch dial list.

Saving/Restoring the directory (Smart card option)

▼ 16 - DIRECTORY / SAVE/LOAD

This function enables you to save the contents of your directory on a Smart card and restore them on your machine.



Important

This function is only available to service technician with Smart card.

To **save** the contents of your directory on your Smart card:

▼ 161 - DIRECTORY / SAVE/LOAD / SAVE

- 1 Press on ▼, enter **16** with the alphanumerical keypad.
- 2 Select **SAVE** to save directory entries on the Smart card.
- 3 Insert your Smart card.

To **restore** the contents of your directory from your Smart card:

▼ 162 - DIRECTORY / SAVE/LOAD / LOAD

- 1 Press on ▼, enter **16** with the alphanumerical keypad.
- 2 Select **LOAD** to restore directory entries from your Smart card.
- 3 Confirm with **OK**.
- 4 Insert your Smart card.

Games and Calendar

Sudoku

Sudoku is a Japanese puzzle. The game is in a grid format of three squares by three squares to be distributed in fields in zones of 3 x 3. Depending on the level of difficulty, more or fewer numbers are already entered at the start of the game. The aim of the game is to distribute the numbers 1 to 9 between the boxes in such a way that each number appears only once in each row, column and in each of the nine grids. There is only one solution.

Print a grid

There are 400 Sudoku grids available in total, 100 for each difficulty level.



Important

The printing is not possible on A5 paper format.

▼ 521 - PRINT / SUDOKU / PRINT GRID

- 1 Press ▼, enter **5** using the keypad. Confirm with **OK**.
- 2 Select **SUDOKU** using the ▼ or ▲ button.
- 3 Confirm with **OK**.
- 4 Select **PRINT GRID** using the ▼ or ▲ button.
- 5 Select the level of difficulty **EASY**, **MEDIUM**, **HARD**, **EVIL** using the ▼ or ▲ button.
- 6 Confirm with **OK**.
- 7 Choose the grid you want by entering the number on the numeric keypad (1 to 100).
- 8 Confirm with **OK**.
- 9 Choose the number of copies you want by entering a number from 1 to 9 on the numeric keypad.
- 10 Confirm with **OK**.

The number of copies of the grid requested is printed.

Print the solution to a grid



Important

The printing is not possible on A5 paper format.

▼ 522 - PRINT / SUDOKU / PRT SOLUTION

- 1 Press ▼, enter **5** using the keypad. Confirm with **OK**.
- 2 Select **SUDOKU** using the ▼ or ▲ button.
- 3 Confirm with **OK**.
- 4 Select **PRT SOLUTION** using the ▼ or ▲ button.
- 5 Select the level of difficulty **EASY**, **MEDIUM**, **HARD**, **EVIL** using the ▼ or ▲ button.
- 6 Confirm with **OK**.
- 7 Choose the grid you want by entering the number on the numeric keypad (1 to 100).

8 Confirm with **OK**.

9 Choose the number of copies you want by entering a number from 1 to 9 on the numeric keypad.

10 Confirm with **OK**.

The number of copies of the solution to the grid requested is printed.

Calendar

This function enables you to print the calendar for a year of your choice.



Important

The printing is not possible on A5 paper format.

▼ 53 - PRINT / CALENDAR

- 1 Press ▼, enter **5** using the keypad. Confirm with **OK**.
- 2 Select **CALENDAR** using the ▼ or ▲ button.
- 3 Confirm with **OK**.
- 4 Choose the year you want to print as calendar by entering the number on the numeric keypad (for example: 2009).



Note

The year must be between 1900 and 2099. Use the C key to correct an entry.

- 5 Confirm with **OK**.

The calendar of the year requested is printed.

USB memory key

You can connect a USB memory Key on the front side of your machine. The files stored in TXT, TIFF and JPEG formats will be analysed and you will be able to use the following actions:

- print the stored files contained in your USB memory key¹,
- delete the files contained in your USB memory key,
- run an analysis on the contents of the inserted USB memory key,
- digitalise a document on your USB memory key,
- fax archiving (See section "Rerouting fax messages to a USB memory key", page 25).

Use of the USB memory key



Important

Always respect the insertion way when you connect a USB memory key to the machine.

Do not disconnect your USB memory key while the machine is reading its contents or writing contents.

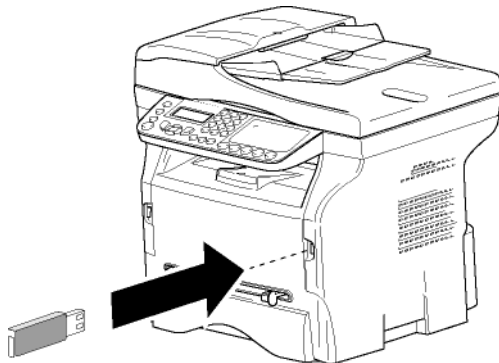

Print your documents



Important

The printing is not possible on A5 paper format.

You can print the stored files or a list of the files located in the USB memory key.

Print the list of files located in the key

To print the list of files located in the key:

▼ 01 - MEDIA / PRINT DOC. / LIST

- 1 Insert the USB memory key on the front side of the machine respecting the way of insertion.
- 2 **ANALYSIS MEDIA** appears on the screen.

1. It may be possible that some TIFF files of your USB memory key cannot be printed due to data format limitation.

- 3 Select **PRINT DOC.** with the ▼ or ▲ buttons and confirm with **OK**.
- 4 Select **LIST** with the ▼ or ▲ buttons and confirm with **OK**.
- 5 The list is shown in a table with the following information:
 - the analyzed files are indexed in an incremental 1 by 1 order,
 - the files name with their extension,
 - the date of the files last save,
 - the files size in Kbytes.

Print the files located in the key

To print the files located in the key:

▼ 01 - MEDIA / PRINT DOC. / FILE

- 1 Insert the USB memory key on the front side of the machine respecting the way of insertion.
- 2 **ANALYSIS MEDIA** appears on the screen.
- 3 Select **PRINT DOC.** with the ▼ or ▲ buttons and confirm with **OK**.
- 4 Select **FILE** with the ▼ or ▲ buttons and confirm with **OK**.
- 5 You have three possibilities to print your files:
 - **ALL**, to print all the files located in the USB memory key. Select **ALL** with the ▼ or ▲ buttons and confirm with **OK**. The printing is started automatically.
 - **SERIES**, to print a series of files located in the USB memory key. Select **SERIES** with the ▼ or ▲ buttons and confirm with **OK**. **FIRST FILE** and the first indexed file appears on the screen. Select with the ▼ or ▲ buttons the first file of the series to print and confirm with **OK**. A star (*) appears on the left side of the file. **LAST FILE** appears on the screen. Select with the ▼ or ▲ buttons the last file of the series to print and confirm with **OK**.

Press the  button.

COPIES NUMBER appears on the screen, enter the desired number of copies with the numerical keypad and confirm with **OK**. Select the printing format (for JPEG files): **A4** or **LETTER** (depending on model), or **PHOTO** and confirm with **OK**.

Select the printing format: **THICK** or **NORMAL** and confirm with **OK** to start printing.

- **SELECTION**, to print one or several files located in the USB memory key.
Select with the ▼ or ▲ buttons the file to print and confirm with **OK**. A star (*) appears on the left side of the file.
Repeat this step for each file you want to print.

Press the  button.

COPIES NUMBER appears on the screen, enter the desired number of copies with the numerical keypad and confirm with **OK**.

Select the printing format (for JPEG files): **A4** or **LETTER** (depending on model), or **PHOTO** and confirm with **OK**.

Select the printing format: **THICK** or **NORMAL** and confirm with **OK** to start printing.

- 6 Quit this menu by pressing the  button.

Delete your files located in the key

You can delete files located in your USB memory key.

▼ 06 - MEDIA / DELETE / MANUAL

- 1 Insert your USB memory key on the front side of your machine respecting the way of insertion. **MEDIA ANALYSIS** appears on the screen.
- 2 Select **DELETE** with the ▼ or ▲ buttons and confirm with **OK**.
- 3 Select **MANUAL** with the ▼ or ▲ buttons and confirm with **OK**.
- 4 You have three possibilities to delete your files:
 - **ALL**, to delete all the files located in the USB memory key.
Select **ALL** with the ▼ or ▲ buttons and confirm with **OK**.
You come back to the previous menu.
 - **SERIES**, to delete a series of files located in the USB memory key.
Select **SERIES** with the ▼ or ▲ buttons and confirm with **OK**.
FIRST FILE and the first indexed file appears on the screen. Select with the ▼ or ▲ buttons the first file of the series to delete and confirm with **OK**. A star (*) appears on the left of the file. **LAST FILE** appears on the screen, select with the ▼ or ▲ buttons the last file of the series to delete and confirm with **OK**. A star (*) appears on the left side of the file.

Press the  button.

You come back to the previous menu.

- **SELECTION**, to delete only one or several files located in the USB memory key.
Select with the ▼ or ▲ buttons the file to delete and confirm with **OK**. A star (*) appears on the left side of the file.
Repeat this step for each file you want to delete.

Press the  button.

You come back to the previous menu.

- 5 Quit this menu by pressing the  button.

Analyse the USB memory key content

After a period of inactivity, your machine will return to the main menu. To view the USB memory key again please proceed as follows:

▼ 07 - MEDIA / ANALYSE MEDIA

- 1 Press on ▼, enter **07** with the keyboard.
- 2 The USB memory key analysis is started.
- 3 You can print or delete the detected files located in your USB memory key. Refer to the previous chapters.

Save a document on a USB memory key

This function allows you to digitise and save a document directly in the folder MFPrinter Laser Pro LL2\SCAN on a USB memory key. The folder MFPrinter Laser Pro LL2\SCAN is created by the application.



Important

Before digitalising a document, make sure that your USB memory key has sufficient disk space. If not, you can delete manually the files. See section "Delete your files located in the key", page 39.

- 1 Place the document to be copied face down on the glass.
- 2 Insert the USB memory key in the USB connector of your multifunction device.
The USB memory key analysis is started. When the analysis is finished, the **MEDIA** menu is displayed.
- 3 Select **SCAN TO** with the ▼ or ▲ buttons then confirm with the **OK** button.

You can also access this function in two other ways:



Important

- by pressing the  button of the machine deck then by selecting **SCAN-TO-MEDIA**.
- By pressing the ▼ button from the screen saver then by typing **03** on the digital keyboard.

- 4 Choose between **B&W SCAN** or **COLOUR SCAN** with the ▼ or ▲ buttons and confirm with **OK**.
- 5 With the alphanumeric keyboard, give a name to the scan file (up to 20 characters) and confirm with **OK**.
- 6 Choose the scan format between **IMAGE** and **PDF**, and confirm to start the scan and the recording of the document.
IMAGE allows to have the same kind of file as a photo. **PDF** is a format for the digital documents creation.



With the **IMAGE** format, if you have selected:

- **BLACK&WHITE**, the picture will be saved in TIFF format.
- **COLOUR**, the picture will be saved in JPEG format.

You can choose the image resolution that will be digitized to the USB memory key; the default resolution is AUTO.

**Important**

Press the  button several times and select the resolution you require:

- Scanning in **BLACK&WHITE**:
 -  icon: text resolution.
 -  icon: photo resolution.
 - no icon: auto resolution.
- Scanning in **COLOUR**:
 -  icon: text resolution.
 - no icon: auto resolution.

The beginning button  immediately starts the scan and sends a file to the support with the parameters defined in the analysis format.

PC Features

Introduction

The Companion Suite Pro software allows the connection of a personal computer with a compatible multifunction machine.

From the PC, you can:

- manage the multifunction machine, allowing you to set it up according to your needs,
- print your documents on the multifunction machine from your usual applications,
- scan colour, grey scale or black and white documents and edit them on your PC, or process them into text using the character recognition software (OCR),

Configuration requirements

The minimum configuration requirements for your personal computer are:

Supported operating systems:

- Windows 2000 with at least Service Pack 4,
- Windows XP x86 (Home and Pro) with at least Service Pack 1,
- Windows 2003 server for printing driver only,
- Windows Vista.

Processor:

- 800 MHz for Windows 2000,
- 1 GHz for Windows XP x86 (Home and Pro),
- 1 GHz for Windows Vista.

A CD-ROM drive

A free USB port

600 Mbytes of available disk space for the installation
RAM memory:

- 128 Mbytes minimum for Windows 2000,
- 192 Mbytes minimum for Windows XP x86 (Home and Pro),
- 1 GByte for Windows Vista.

Software installation

This section describes the following installation procedures:

- full installation of the Companion Suite Pro software,
- installation of the drivers only.

Installing the full software package

Turn your PC on. Open an account session with the administration rights.

- 1 Open the CD-ROM drive, insert the installation CD-ROM and close the drive.
- 2 An installation procedure is automatically run (Auto run). If it does not, double-click on setup.exe at the CD-ROM's root.
- 3 A screen titled **COMPANION SUITE PRO LL2** appears. This screen allows you to install and uninstall the software, access the product's user guides or browse the CD-ROM contents.
- 4 Place your cursor on **INSTALL PRODUCTS** and confirm with left-click of the mouse.



- 5 The Products Installation screen appears. Place your cursor on **ALL PRODUCTS** and confirm by left-click with the mouse.

For full installation copies on your hard disk the software required for the good execution of the Companion Suite Pro kit, which is:

- Companion Suite Pro LL2 (machine management software, printer drivers, scanner, ...),
- Adobe Acrobat Reader,
- PaperPort®SE.



Note

You may already be the owner of a version of the software available in the installation CD-ROM.

*In this case use the **CUSTOMIZED** installation, select the software that you want to install on your hard drive and confirm your choice.*



- 6 The welcome screen appears. Click on the **NEXT** button to launch the installation of the Companion Suite Pro in your PC.

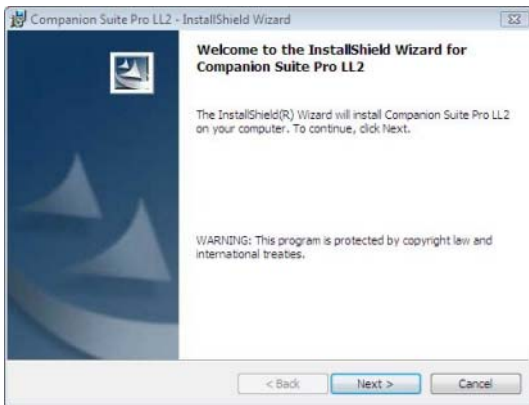

- 7 To continue, you need to accept the proposed license agreement.



- 8 Click on the **NEXT** button.

- 9 The final installation is ready to be executed. Click on the **INSTALL** button.

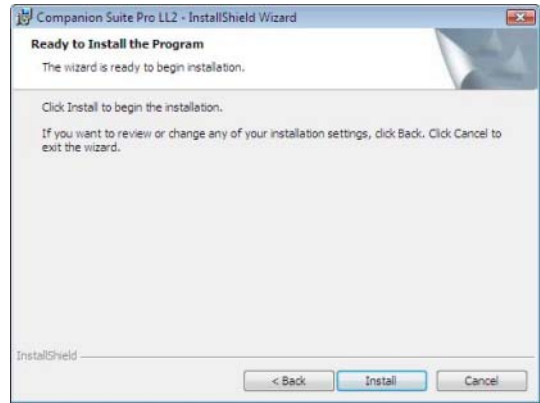

The following screen appears to indicate the progression of the installation.



- 10 Click on **OK** to finish the installation.



Your Companion Suite Pro kit is successfully installed on your PC.

You can now connect your multifunction machine, refer to chapter **Connections**.

You can start the multifunction machine's management software from the menu **START > ALL PROGRAMS > COMPANION SUITE > COMPANION SUITE PRO LL2 > COMPANION DIRECTOR** or by clicking on the icon **COMPANION - DIRECTOR** located on your desktop.

Installing drivers only

This section describes the following installation procedures:

- installation of drivers using the Companion Suite Pro software,
- manual installation of drivers.

Installing the drivers using the Companion Suite Pro software

Turn your PC on. Open an account session with the administration rights.

- 1 Open the CD-ROM drive, insert the installation CD-ROM and close the drive.
- 2 An installation procedure is automatically run (Auto run). If it does not, double-click on setup.exe at the CD-ROM's root.
- 3 A screen titled **COMPANION SUITE PRO LL2** appears. This screen allows you to install and uninstall the software, access the product's user guides or browse the CD-ROM contents.
- 4 Place your cursor on **INSTALL PRODUCTS** and confirm with left-click of the mouse.



- 5 The Products Installation screen appears. Place your cursor on **CUSTOMIZED** and confirm by left-click with the mouse.



- 6 Place your cursor on **COMPANION SUITE PRO LL2** and confirm with left-click of the mouse.

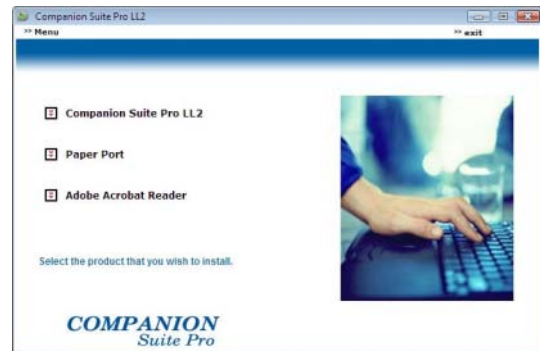

- 7 The welcome screen appears. Click on the **NEXT** button to launch the installation of the Companion Suite Pro kit on your PC.

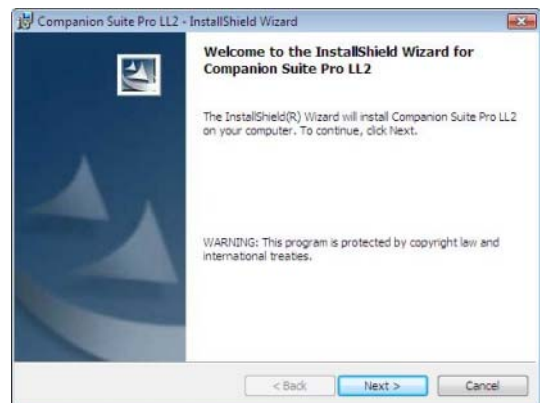

- 8 To continue, you need to accept the proposed license agreement.



- 9 Click on the **NEXT** button.
- 10 Select **INSTALL DRIVERS** in the list and click on the **NEXT** button.

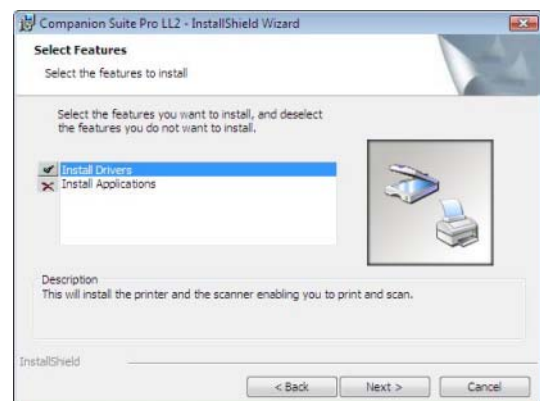

- 11 Select the destination folder for installation and click on the **NEXT** button.

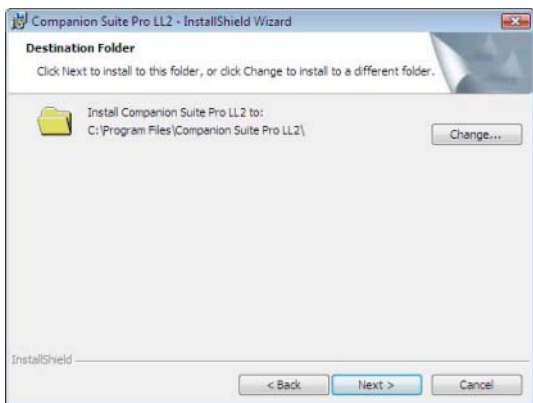

- 12 The final installation is ready to be executed. Click on the **INSTALL** button.

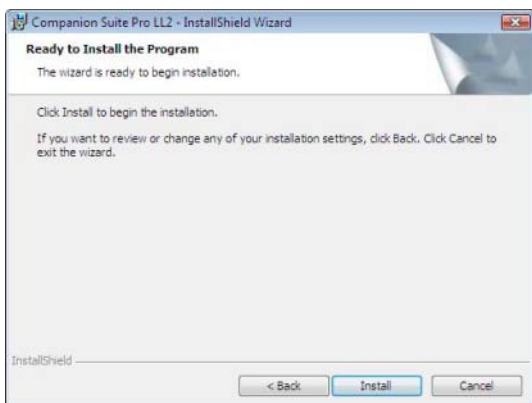

- 13 A screen informs you of the installation progress.

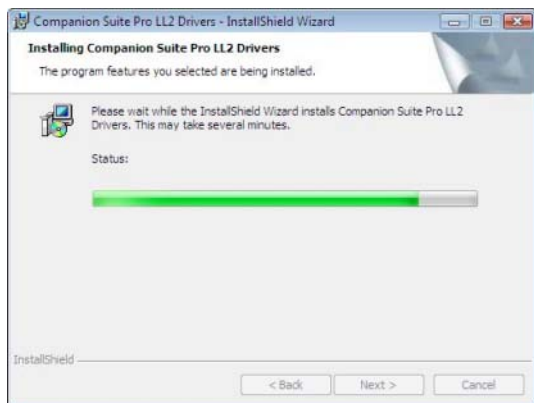

- 14 Click on **OK** to finish the installation.



The Companion Suite Pro software is now installed on your PC.

You can now connect your multifunction machine, refer to chapter **Connections**.

Installing the drivers manually

You can install the printer and scan drivers manually without running any setup software.



Note

This installation mode is only possible on Windows 2000, XP and Vista.

- 1 Locate your USB cable connectors and connect as shown below on the picture.

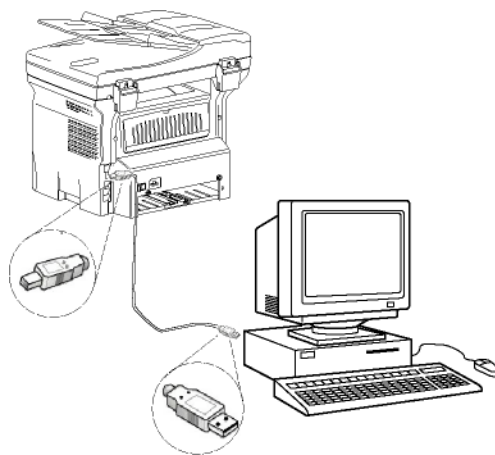

- 2 Power on your multifunction machine. The PC detects the device.
- 3 Click on **LOCATE AND INSTALL DRIVER SOFTWARE (RECOMMENDED)**.



The following screen appears:

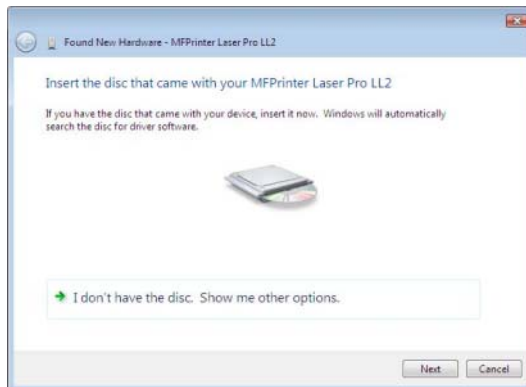

- 4 Open the CD-ROM drive, insert the installation CD-ROM and close the drive. The drivers are detected automatically.

- 5 Select LASER PRO LL2 in the list and click on **NEXT**.

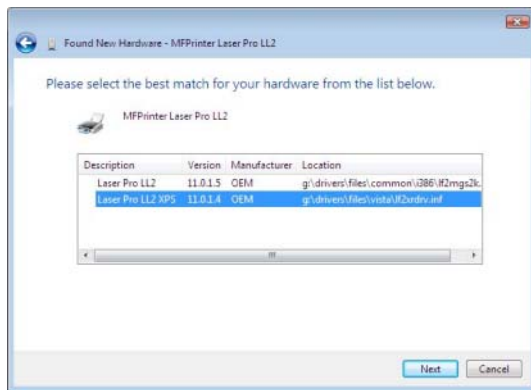

- 6 A screen informs you that the drivers have been installed. Click on the **CLOSE** button.

You can now use the multifunction machine to print or scan your documents.

Connections

Make sure that your multifunction machine is powered off. The connection between the PC and the machine requires a USB 2.0 shielded cable no more than 3 meters long.

It is recommended to install the Companion Suite Pro software first and then to connect the USB cable to your machine (See section “Installing the full software package”, page 41.).



Important

*If you connect the USB cable before installing the Companion Suite Pro software the recognition system (plug and play) identifies automatically that new hardware has been added. To start your machine drivers installation, refer to chapter **Installing the drivers manually** and follow the instructions on screen. When you use this procedure, only printing and scanning functions are activated.*

- 1 Locate your USB cable connectors and connect as shown below on the picture.

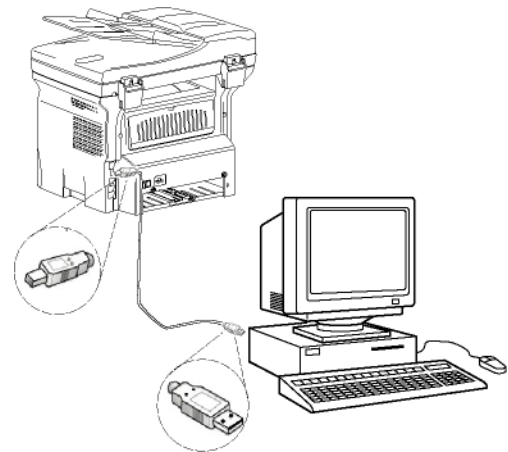

- 2 Power on your multifunction machine. The PC detects the device and the drivers are automatically installed.
- 3 Once the installation is finished, a message indicates that the drivers are installed correctly.



You can now use the multifunction machine to print or scan your documents.

Multifunction Terminal's Supervision

The software that you have installed contains two multifunction machine management applications, **COMPANION DIRECTOR** and **COMPANION MONITOR**, which allow you to:

- check whether the multifunction machine is connected to your PC,
- monitor the multifunction machine activities,
- monitor the status of the multifunction machine consumables from the PC,
- quickly access the graphic editor applications.

To manage the multifunction machine, run the Companion Director application by clicking on the icon located on your desktop or from the menu **START > ALL PROGRAMS > COMPANION SUITE > COMPANION SUITE PRO LL2 > COMPANION DIRECTOR**.

Checking the connection between the PC and the multifunction machine

To check if the connection between the devices is good, run the **COMPANION MONITOR** software from the icon located on the desktop and check that the same information is displayed on the multifunction machine.

Companion Director

This graphical Interface allows you to run the utilities and the software to manage your multifunction machine.

Graphical presentation

Run the application by clicking on the **COMPANION DIRECTOR** icon located on your desktop or from the menu **START > ALL PROGRAMS > COMPANION SUITE > COMPANION SUITE PRO LL2 > COMPANION DIRECTOR**.



Utilities and applications activation

The Companion Suite Pro graphical interface allows you to run the following utilities and software:

- get **HELP** from the current documentation,
- run the **PAPERPORT** software (Doc Manager).

To run a software or utility contained in the Companion Suite Pro kit, place the cursor on it and left-click with the mouse.

Companion Monitor

Graphical presentation

Run the application by clicking on the **COMPANION MONITOR** icon located on your desktop or from the menu **START > ALL PROGRAMS > COMPANION SUITE > COMPANION SUITE PRO LL2 > COMPANION MONITOR**.

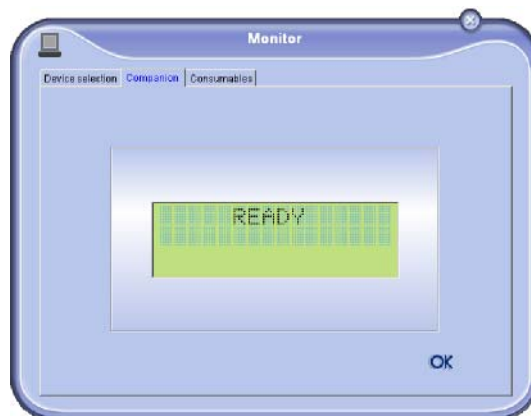

From this screen you can monitor the information or configure your multifunction machine from the tabs:

- **DEVICE SELECTION:** Displays the list of devices managed by the PC.
- **COMPANION:** Presents the multifunction machine screen (USB only, not compatible with Chinese, Korean and Russian languages).
- **CONSUMABLES:** Displays the consumables status.

Device management

This tab shows the list of devices managed by the PC.

Selecting the current device

Only one device at a time may be connected to the PC. The current device may be selected by clicking on the radio button corresponding to the device.

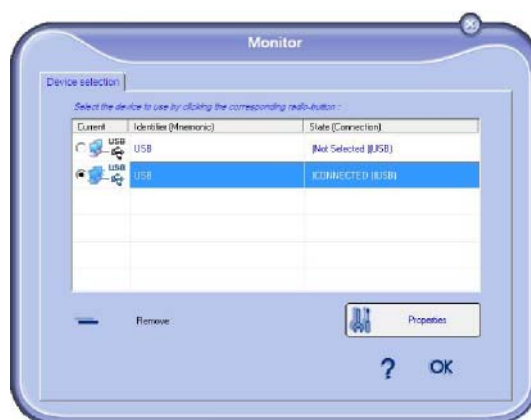

Status of the connection

The status of the connection between the current device and the PC is indicated by a colour. The following table defines the possible states of the connection.

Colour	State
Yellow	Connection in progress.
Green	Connection established.
Red	The PC cannot connect to the device. Check the USB connection.

Device parameters

- 1 Select a device by clicking on its line in the list and click on **PROPERTIES** to configure the scanning parameters to be applied for this device when you use the **SCAN TO** function.

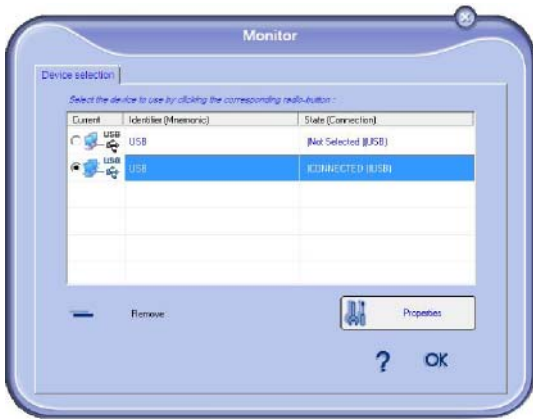

- 2 Select the desired scan **MODE** in the drop-down menu.



- 3 Select the desired scan **RESOLUTION** in the drop-down menu.



- 4 Click **OK** to confirm the new parameters.

Display the consumable status

The following information will be available from the **CONSUMABLES** tab:

- current consumables status,
- number of printed pages,
- number of scanned pages,
- number of sent and received pages.

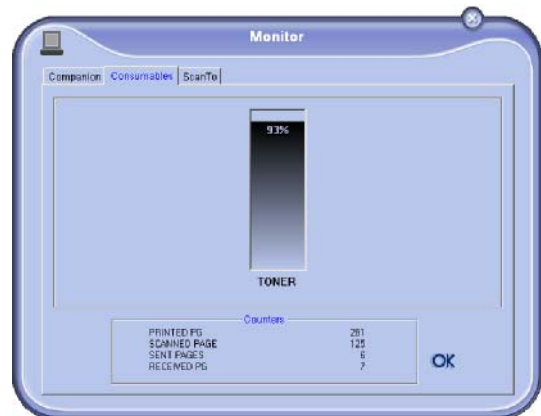

Companion Suite Pro functionalities

Document analysis

The document analysis can be carried out in two ways:

- either by the **SCAN TO** function (application accessible from the Companion Director window or from the **SCAN** button on the machine),
- or directly from a standard compatible application.

Analysis with Scan To

Run the application by clicking on the **COMPANION DIRECTOR** icon located on your desktop or from the menu **START > ALL PROGRAMS > COMPANION SUITE > COMPANION SUITE PRO LL2 > COMPANION DIRECTOR**.



- 1 Click on the **SCAN To** graphical image or press the **SCAN** button on your machine and select **SCAN-TO-PC**.
- 2 You can follow the ongoing digitisation on a screen.



- 3 At the end of the digitisation, the scanned picture appears in the PaperPort window.

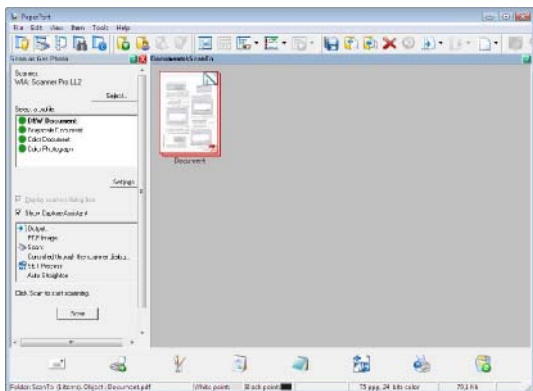

- 2 Select the desired scanner, document feeder or flatbed.

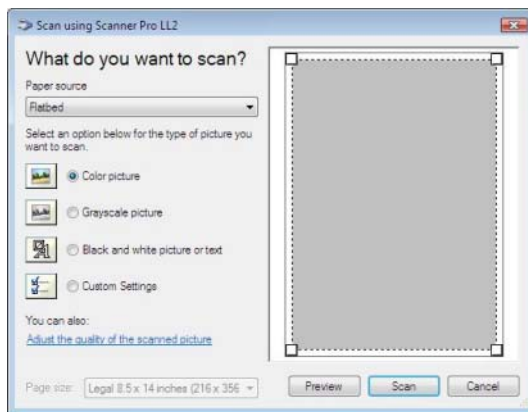

- 3 Customise the advanced properties of the digitisation by clicking on the **ADJUST THE QUALITY OF THE SCANNED PICTURE** link.
- 4 Adjust the desired parameters and click on the **OK** button.

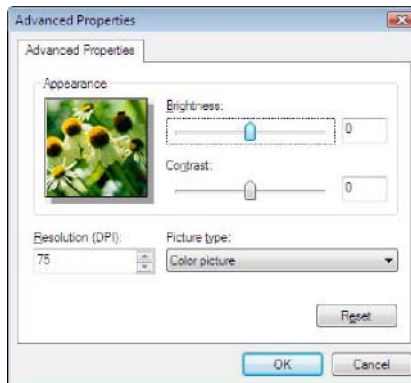

- 5 Click on the **SCAN** button, you can follow the ongoing digitisation on a screen.

Character recognition software (OCR)

The character recognition function allows to create a usable data file for desktop applications from a hardcopy document or from a picture.

The character recognition only works for printed characters, such as printer outputs or typed text. Nevertheless you can request for a handwritten text block to be kept intact (a signature for instance) by outlining it.

Given your machine environment and the character recognition from your machine, the OCR is done with a Drag&drop of a document from the PaperPort to the

Notepad icon .



Note

If the PaperPort software is not installed on your hard drive, the scanned picture will appear on your desktop in TIFF format.



Note

For more details about the usage of this software, check the online help of the product.

To scan a document from PaperPort:

- 1 Click on **FILE > SCAN**.

Printing

You have the possibility to print your documents via the USB connection.

During the installation of the Companion Suite Pro software, the **LASER PRO LL2** printer driver will be installed automatically onto your PC.

Printing on the multifunction machine

Printing a document on the multifunction machine from your PC is like printing a document in Windows.

- 1 Use the **PRINT** command from the **FILE** menu of the currently open application on the screen.
- 2 Select the **LASER PRO LL2** printer.

Printing in duplex mode with the multifunction machine

The machine offers the possibility to print a document in manual duplex mode from your PC.

In manual duplex, the print quality and paper transport are not guaranteed.

- If some trouble occurred to the paper during the print of the first side, such as wrinkle, dog ear or staple, do not use the paper for manual duplex.

- When you load paper, please true up the end of paper on a flat surface.

For best results, we recommend that you use 80 g/m² A4 paper or 20 lbs/m² Letter paper.



Warning

- 3 Check the **Duplex** box and choose among the two binding modes:

Binding mode	Printing
Long sides	
Short sides	

- 4 Click on the **OK** button to begin printing.
- 5 The machine prints the odd pages (from the higher odd page to page 1) and the LCD screen displays:

**** PRINTING ****
**** PC ****

- 6 Once the odd pages are printed, the LCD screen displays the message ****PUT THE PRINTED SHEETS IN THE PAPER TRAY WITH THE PRINTED SIDE VISIBLE...:**

**** PUT THE PRIN**
... AND PRESS <OK>



Important

The PC generates and prints a page explaining how to reload the sheets for a duplex job. Read this page carefully and place it back with the other sheets. It is very important that you return the explanation sheet to the paper tray to continue printing correctly.

To print a document in manual duplex mode:



Important

The duplex printing mode is available only in a paper format managed by the paper tray. The manual tray cannot be used to print in duplex mode.

- 1 Use the **PRINT** command from the **FILE** menu of the currently open application on the screen.
- 2 Select the **LASER PRO LL2** printer.

- 7 Place the sheets in the paper tray as indicated on the explanation page and below. The following illustrations describe the necessary operations depending on the selected binding mode:

- Long sides

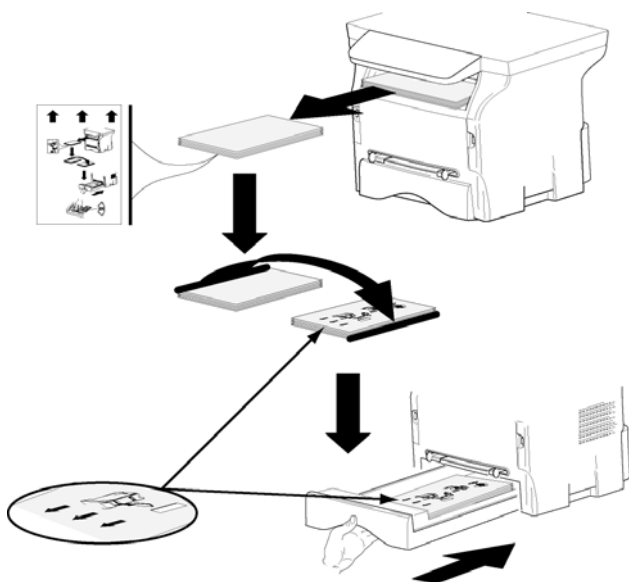

- Short sides

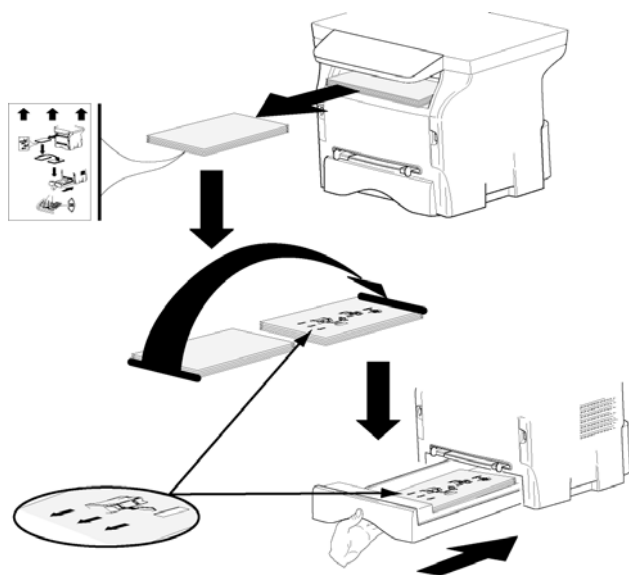

- 8 Press **OK** on the command panel to resume printing.
- 9 Even pages are printed on the other side of the sheets. Once all pages are printed, remove the explanation sheet.

Important

If a paper jam or a paper format error occurs, the job is cancelled. You must then resubmit the print job.

Address book

The address book enables you to store the numbers of the contacts you call the most frequently. The purpose of this function is to facilitate dialling your contact's number when you want to send fax. If you want, you can print the list of numbers stored in the Directory.

You also have the possibility of creating groups of contacts from the Address book. Like this, you can group together all contacts from, for example, a given company or the same service, etc, to which you frequently send common documents.

Important

The software can also manage the address books of the operating system of the messaging software installed on the PC. The method of use of these address books is not detailed in this manual. Check with the online documentation of the software for more details.

Add a contact to the terminal address book

- 1 Click on the link **ADDRESS BOOK** of the window **MF DIRECTOR**.
The address book is displayed on the screen.

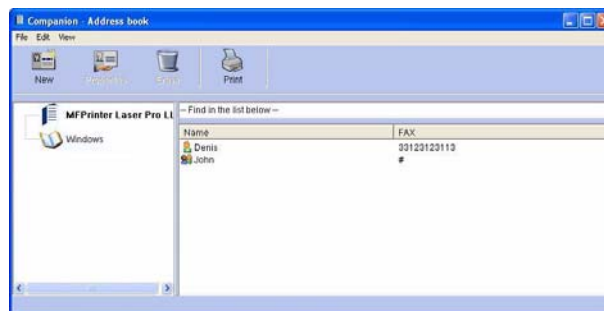

- 2 Select the terminal address book.
- 3 Click on **NEW** and select **CONTACT** in the displayed menu.
The input window for the contact data is displayed..



- 4 Enter the contact name as well as the fax number, the fax transmission rate with this person and the associated quick dial button. Click on **OK**.

The new contact is added to the list.

Add a group to the terminal address book

- 1 Click the link **ADDRESS BOOK** of the window **MF DIRECTOR**.

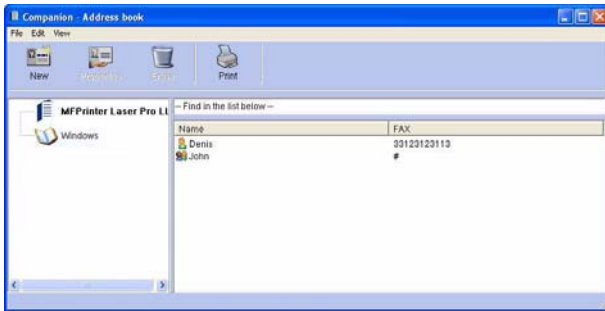

2. Select the terminal address book.
- 3 Click **NEW** and select **GROUP** in the displayed menu.

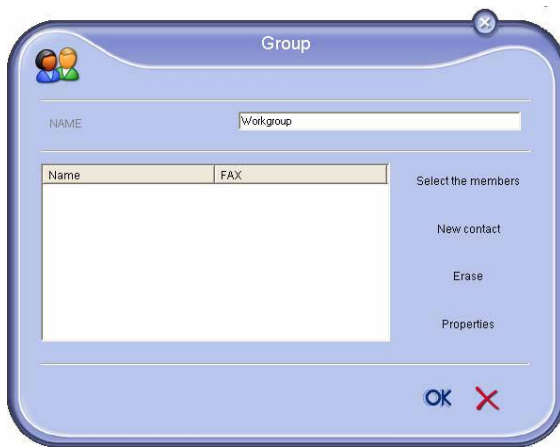

- 4 Enter the name of the group. The group may consist of contacts from the address book or new contacts.

1st case: group members are from the address book.

Click **SELECT THE MEMBERS**.

The selection window is displayed.

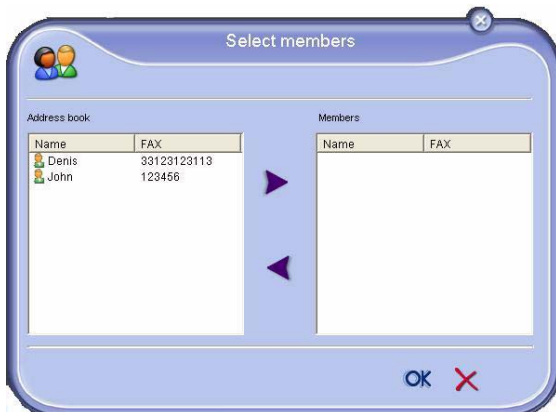

Select a contact or a group in the zone **ADDRESS BOOK**, click on ► (to add a contact to the group you can also double click on it).
Click on **OK**.

2nd case: adding new contacts.

Click on **NEW** then add the personal data of the new

contact, as in the procedure for adding a contact.

- 5 As soon as the group is complete, click on **OK**.
The new group is added to the list.

Manage the address book

When you are working in the directory, you can perform different operations:

- print a list of contacts in your address book,
- delete a contact or a group in your address book,
- search for a contact or a group of contacts in the address book using the first letters of the name,
- check the datasheet of a contact or a group in order to modify it.

Modify the information related to a contact

- 1 Select the contact whose data you want to modify, using the mouse.
- 2 Click on **PROPERTIES**.
- 3 Make the necessary changes in the window **ADDRESS BOOK**.
- 4 Click on **OK**.

Modify a group

- 1 Select the group in the address book list.
- 2 Click on **PROPERTIES**.
- 3 Make the necessary changes.
- 4 Click on **OK**.

Delete a contact or a group from the address book

- 1 Select the name of the contact or the name of the group you want to delete, using the mouse.
- 2 Click on **DELETE**.



Important

When a contact is deleted from the directory, it is automatically deleted from any group in which it may be included.

Print the address book

- 1 Click on **PRINT**.
The list of the address book is printed on the terminal (if no contact is selected).

Import or export an address book

Save / Export your address book

This operation lets you save your address book to a file in XML format.

- 1 Select **EXPORT** in the menu **FILE** of the window **ADDRESS BOOK**.
- 2 Enter the name of the file and select the destination directory, then click on **SAVE**.

Import an address book

Importing an address book makes it possible to exchange address book entries between two devices without having to enter contacts one by one manually. Address books can be imported from files in XML format. XML files are automatically generated during export.



Important

The whole address book will be replaced by the imported address book.

- 1 Select **IMPORT** in the menu **FILE** of the window **ADDRESS BOOK**.
- 2 Select the file to import, click on **OPEN**.

Fax communications

The fax communication enables you to:

- send documents as faxes from one of the scanners of your terminal, from the hard disk or from the screen of your PC,
- to receive fax documents,
- to monitor communications through various services: the inbox, the outbox, the sent items, the outbox log and the inbox log.

Parameters are available to modify the way your terminal works with regard to fax communications. You can modify these parameters to adapt the fax communications to your requirements. For this procedure, refer to chapter **Fax parameters**.

Presentation of the Fax window

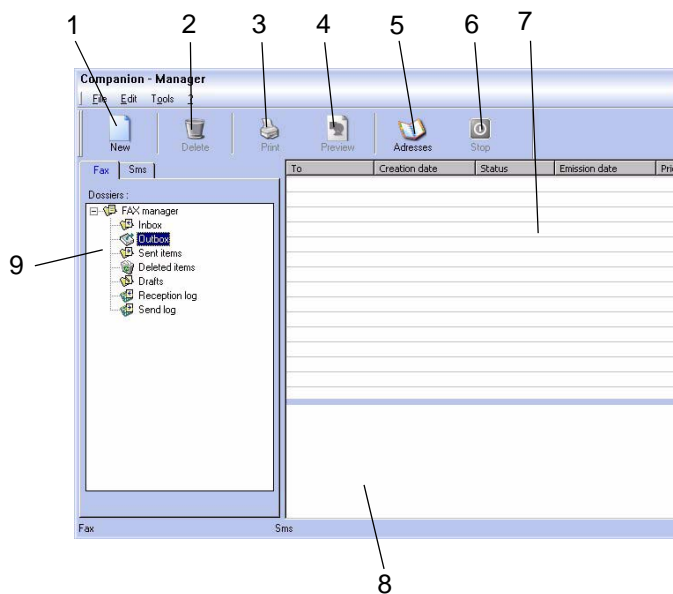

Item	Action
1	Create a new fax to send.



Item	Action
2	Delete a fax using one of the fax manager directories. Except for directories SENT LOG and RECEPTION LOG for which the effect of this command is to delete the entire log
3	Print a fax from one of the Fax manager directories.
4	Display a fax with the Viewer.
5	Access to the address book.
6	Stop sending a fax (only enabled for the outbox).
7	Display all faxes in the selected directory in the Fax manager.
8	Fax preview.
9	Fax manager directories.

Send a fax

Send a fax from the hard disk or the terminal

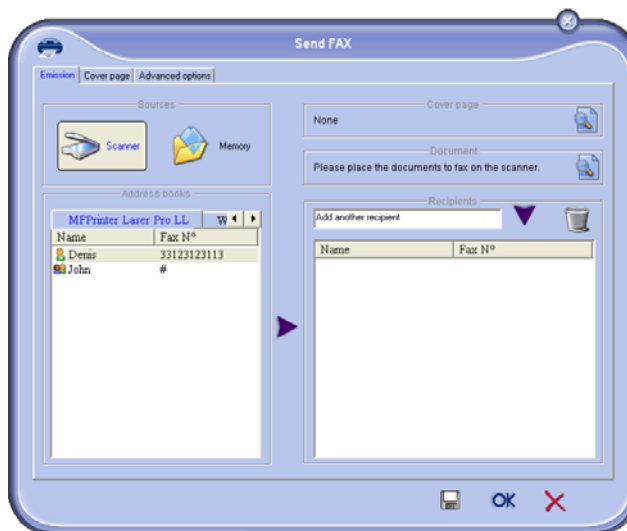
- 1 Click the icon  of the window MF DIRECTOR.
- 2 Click **NEW** then click **FAX**.



- 3 Select **SCANNER** if your document is in paper format or **MEMORY** if the document is a computer file located on your hard disk (this file must be in TIFF or FAX format).
- 4 To send your fax to a contact, enter his number in the field **RECIPIENTS** and click on  or select a contact (or group) from one of the directories in the field **ADDRESS BOOK** and click on the button . Repeat this operation as many times as necessary (use the button  to delete a contact from the list of contacts).

- 5 If necessary, adjust the advanced options (send later and resolution) in the tab **ADVANCED OPTIONS**.

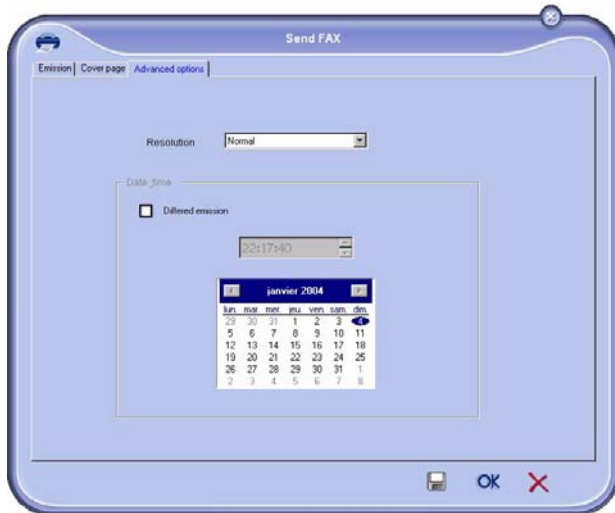

- 6 To add a cover sheet, select the tab **COVER PAGE** then click the box **WITH THE COVER PAGE**. Select the cover sheet you want to add from the pop-down menu, or create a new one. For more information, refer to chapter **Cover sheet**.
- 7 Click **OK** to send your fax to all contacts in your list of contacts.

Your send request can then be checked, if necessary, in the outbox.

Send a fax from application

This method is used to directly send a document you have created using a desktop software without printing it beforehand.

- 1 From your desktop software, select **FILE > PRINT**.

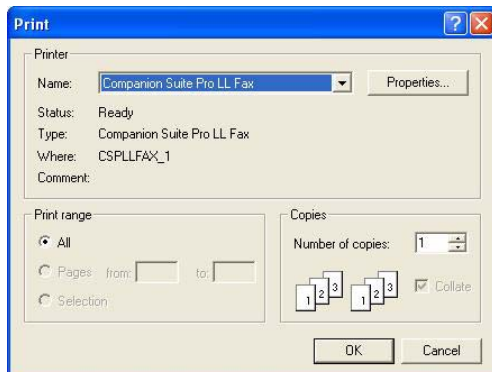

- 2 Select the printer **COMPANION SUITE PRO LL FAX** and click **OK**.

The fax outbox window is displayed.

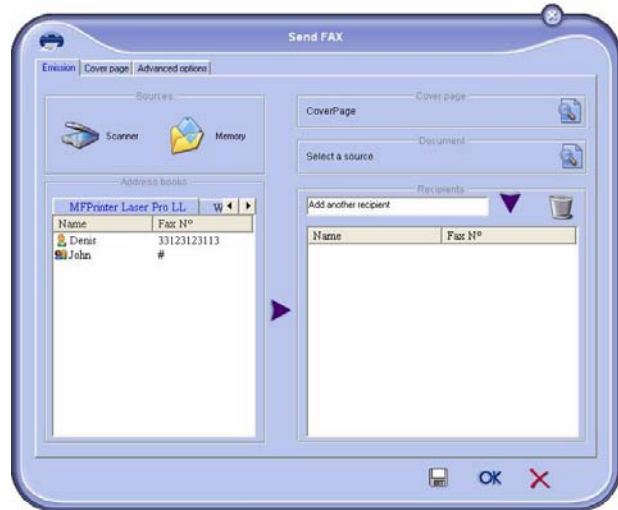

- 3 To send your fax to a contact, enter his number in the field **RECIPIENTS** and click the button ▼ or select a contact (or a group) from one of the directories in the field **ADDRESS BOOK** and click the button ►.
- Repeat this operation as many times as necessary (use the button ☒ to delete a contact from the list of contacts).
- 4 If necessary, adjust the advanced options (send later and resolution) in the tab **ADVANCED OPTIONS**.
- 5 To add a cover sheet, select the tab **COVER PAGE** then click the box **WITH THE COVER PAGE**. Select the cover sheet you want to add from the pop-down menu, or create a new one. For more information, refer to chapter **Cover sheet**.
- 6 Click **OK** to send your fax to all contacts in your list of contacts.
- 7 Your send request can then be checked, if necessary, in the outbox.

Receive a fax

The window **MF Manager** and **MF Director** show, using different messages, the reception of a fax. The icon ↻ is displayed at the bottom of the window **MF Manager** and the icon 🔄 appears in the task bar..

You can automatically print faxes on reception. To do this, you have to define this parameter, refer to chapter **Fax parameters**.

Follow-up of fax communications

Follow-up of fax communications is by means of:

- an outbox,
- an inbox,
- a sent item memory,
- an outbox log,
- an inbox log.

These services enable you to always know exactly what communications are taking place on the terminal, whether sending or receiving.

The outbox and inbox logs are automatically printed when their contents fill a page. After automatic printout, the terminal creates a new log.

The outbox

In the fax outbox, there are the following:

- the requests being sent,
- the send later requests,
- the requests for which one or more send attempts have already been made, and which will soon be redialed,
- the rejected requests (calls not put through).

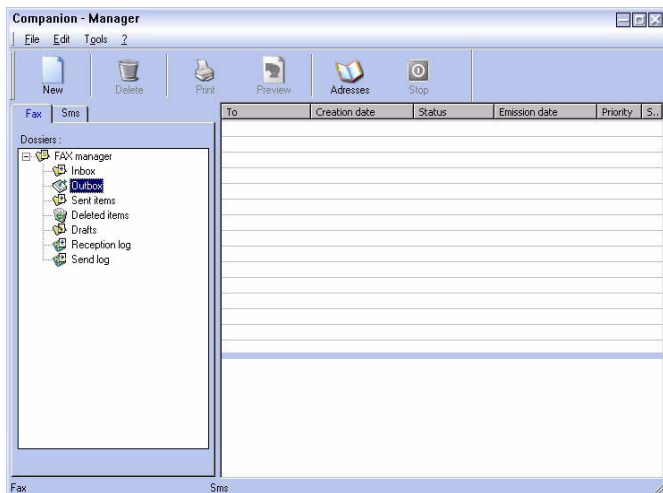

The requests are classed in the order in which they are executed.

The rejected requests are filed at the end of the list so that they are more accessible if you want to work with them (request a new send) or delete them.

The send memory (items sent)

The sent memory is used to keep all faxes you have sent. The information in the send memory is:

- the recipient of the fax,
- the date the fax was created,
- the date the fax was sent,
- the size of the fax.

The outbox log

The outbox log is used to keep a history of all fax communications (successful or rejected) that your Terminal processes. The log is printed automatically as soon as its contents fill a page.



Important

The button **DELETE** deletes the entire log, and not simply the selected message(s).

The information held in the log is:

- the recipient of the fax,
- the date the fax was sent,
- the status (sent, rejected ...).

The inbox log

The inbox log is used to keep a history of all faxes received by your Terminal. The log is printed automatically as soon as its contents fill a page.



Important

The button **DELETE** deletes the entire log, and not simply the selected message(s).

The information held in the inbox log is:

- the sender of the fax,
- the date and reception of the fax,
- the status.

Fax parameters

Access to fax parameters

- 1 Click on the icon  of the window MF DIRECTOR.
- 2 Select **TOOLS > OPTION > FAX**.
- 3 Make the adjustments require, referring to the description of parameters below and click **OK**.

Description of the tab LOG AND REPORT

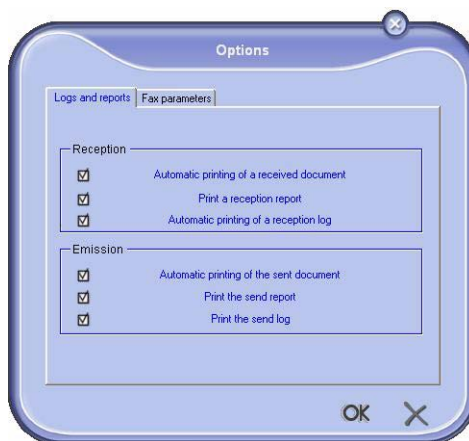

Field	Description
Automatic printing of a received document	The fax is automatically printed when received.
Printing of a inbox report	A report is printed out for each fax received.
Printing of inbox log	The log is automatically printed when it fills an A4 page.
Automatic printing of a sent document	The fax is automatically printed when it is sent.
Printing of an outbox report	An outbox report is printed after each fax is sent
Printing of the outbox log	The log is automatically printed when its contents fill page.

Description of the tab FAX PARAMETERS

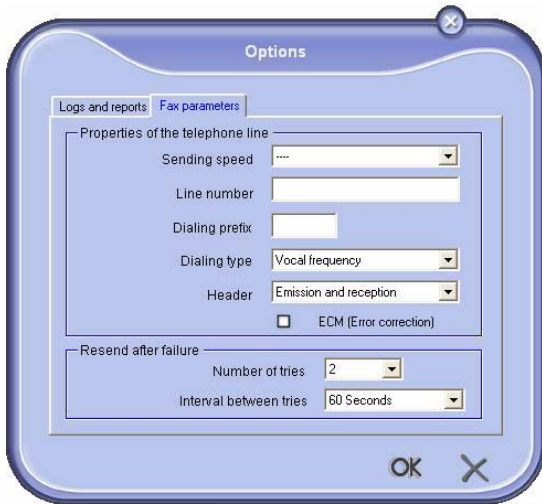

Field	Description
Transmission speed	Fax default transmission speed.
Line number	Number of the line where your terminal is connected.
Dialling prefix	This dialling prefix shall be automatically inserted in front of the number before sending on this line.
Type of dialling	Must be parametered according to the type of switchboard your terminal is connected to.
Header	Displays a Communication Identification Line (LIC) on the documents you send or on the documents you receive.
ECM	Corrects communication errors due to line disturbance. This option ensures that received documents are integral. On the other hand, communication times may be longer if the line is bad.
Number of attempts	Number of attempts the Terminal must make if send fails.
Interval between attempts	Duration between two send attempts.

Cover sheet

The cover sheet is part of a fax document automatically generated by your terminal, on which there is information concerning the sender, the recipient, the date, the time sent, comments, etc...

This page may be sent alone or in front of a fax document, but always at the same time as the document. A document may be sent with a cover sheet from the multifunction terminal or from the central processing unit. In the latter case, some of the information in the cover sheet may be provided by yourself when making the send request. It is necessary to create model cover sheets before sending a document using them. On the other hand, once the cover sheet is created, a model cover sheet may be used for all documents sent.

Your terminal offers the possibility of creating and customizing some model cover sheets which you can choose when sending a fax.

Creating a cover sheet





Important

It is necessary to create a model cover sheet before sending a fax with it.

- 1 From the tab COVER PAGE, click on the button NEW.
- 2 Select the model cover sheet you have created using the menu FILE.

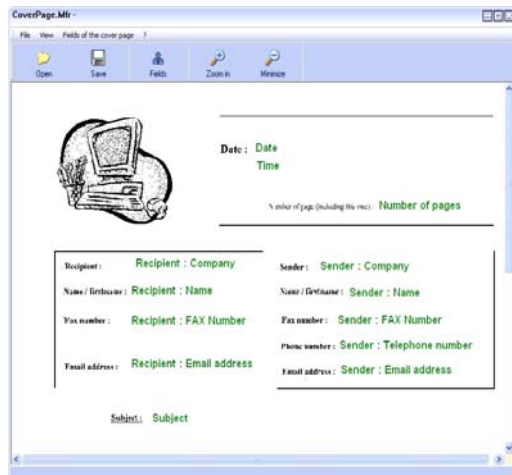
A window with the model cover sheet you have created is displayed:



3 Click on the icon  to display the available fields.

Description of the tab COVER PAGE

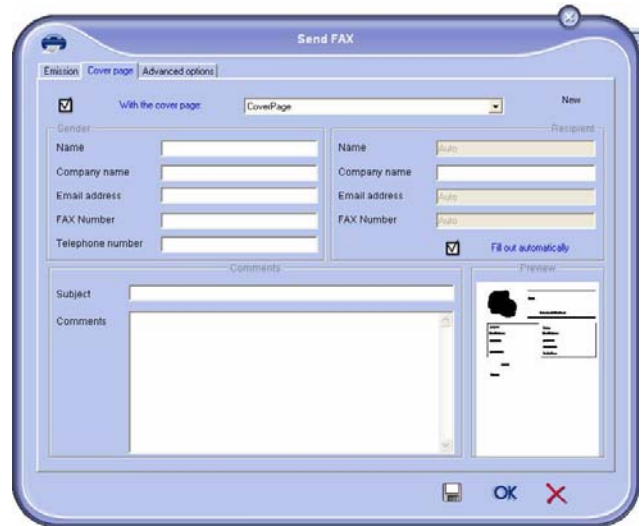
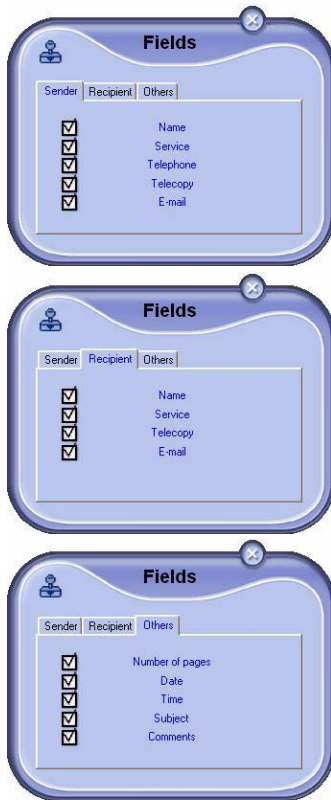

- To add a field, proceed as follows:
- Select the field you want to insert by clicking the field palette. A stamp replaces the cursor of your mouse.
 - Click the location where you want to put the field on the model.
 - You can move or enlarge the field as you like.



Important

Adjust the size of your field so that the text is readable.

4 As soon as fields are inserted, save the cover sheet.

This cover sheet can be selected in the tab COVER PAGE of the fax send window.

Field	Description
Name of the cover sheet	Either the name of the page selected by default or the page you have selected to use.
Sender	You can enter information concerning the sender.
Destination: Name, Company, Department	<p>You can enter information concerning the recipient.</p> <p>If you want these fields to be automatically filled in for recipients already listed in the directory (as favorites, group or distribution list), type "Auto" in the desired fields.</p> <p>When sending a fax, the cover sheet fields are updated if the recipient is listed in the directory.</p>
Comments	This is an editing window with all the basic functions of a text editor so that you can enter a text which will be sent in the cover sheet.
Preview of the model	The preview enables you to see the cover sheet you are going to send.

Creating a cover page template

Creating a cover page creates a template which fields (fax number, comment, subject, etc.) will be automatically filled by the Fax Application depending on the information provided for each recipient of a document.

To create this cover page template, there are two major steps:

- **First step** : Create a background image with the logos and the layout that you wish.
- **Second step** : Add the field that you want to be displayed in the cover page: fax number, comment, subject, etc. As mentioned before, these fields will be filled by Fax application at emission time.

For the first step, there are two methods to create the background image.

You can either

- Option **(A)**: Draw this background image in your preferred application (such as Word, Excel,...),
- OR
- Option **(B)**: Scan a sheet of paper containing the layout of the cover page.

Details about Option A and B:

- Option **(A)**: Open the application that you want to use to edit the background (Word, Wordpad...). Draw the background image then print this document in the printer named "Companion Suite Fax". At that point the MFSendFax dialog is displayed:

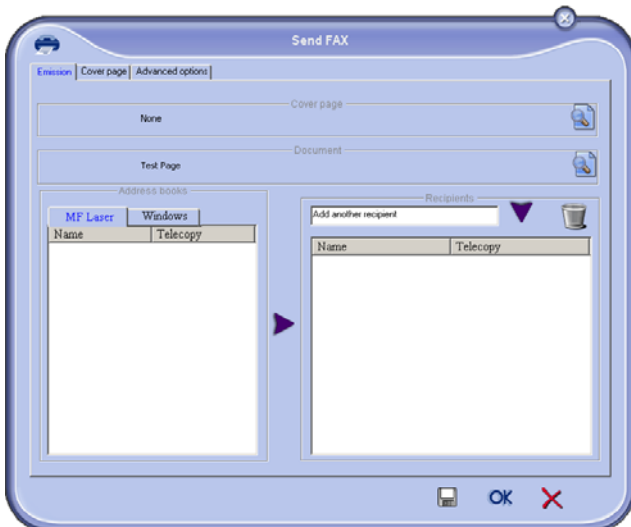

Add any recipient to the recipient list, click on the tab **ADVANCED OPTIONS**, select resolution **NORMAL** as shown below:

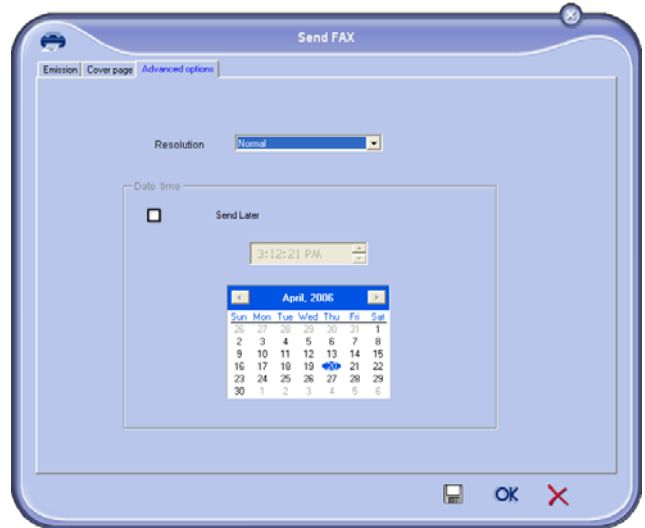

Finally click on the button **SAVE AS DRAFT** in the lower right corner (this is the button with the floppy disk icon). The background image is created in the directory C:\Program Files\Companion Suite Pro LL 2\Documents\FAX\Temporary and has the file extension.fax

- Option **(B)**: Launch **MFMANAGER**, select **NEW FAX**, select the scanner source as shown below :

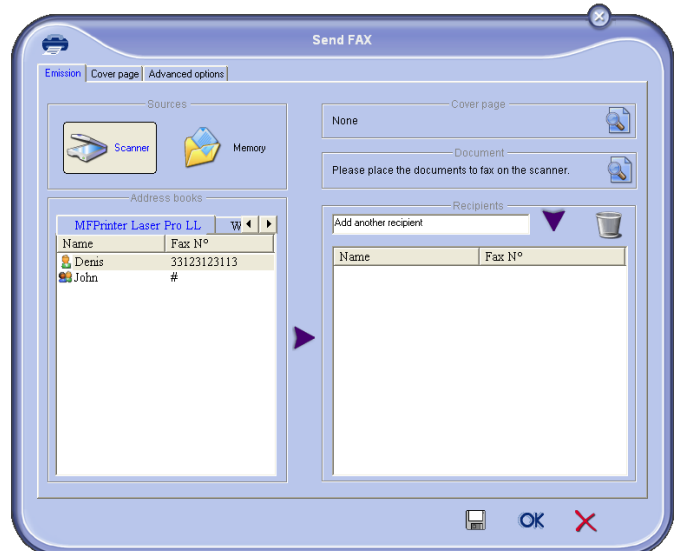

Add any recipient to the recipient list, click on the tab **ADVANCED OPTIONS**, select resolution **NORMAL** as shown below:

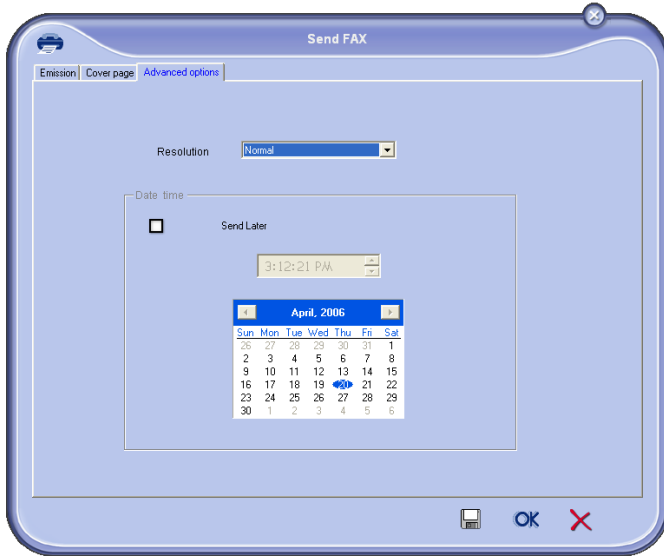

Finally click on the button **SAVE AS DRAFT** in the lower right corner (this is the button with the floppy disk icon). The background image is created in the directory C:\Program Files\Companion Suite Pro LL 2\Documents\FAX\Temporary and has the file extension .fax.

Whether you choose Option **A** or **B**, you end up with a background image with extension .fax, which is located in C:\Program Files\Companion Suite Pro LL 2\Documents\FAX\Temporary.

➔ You can now proceed to the second step right below.

For the second step:

Now that the background image is created in directory in C:\Program Files\Companion Suite Pro LL 2\Documents\FAX\Temporary, you can add the fields on top of the background image.

Please follow the procedure below:

- (a) Launch **MFMANAGER**, select **NEW FAX**, click on the tab **COVER PAGE**, and check the check box named **WITH THE COVER PAGE**.
- (b) Click on the button **NEW**, this displays a new window with the title **CREATION OF THE COVER PAGE**.
- (c) Press the button **OPEN** in the toolbar, change the file format to *.fax and browse to the directory C:\Program Files\Companion Suite Pro LL 2\Documents\FAX\Temporary that contains the background image that you have created in the **First step**.
- (d) Click on the button **FIELDS** in the toolbar, a window pops up allowing you to add the fields on top of the background image.
- (e) Click on the button **SAVE** to save the Cover Page template and exit this window.
- (f) The window **NEW FAX** is displayed, you can now choose the Cover Page template that you want to use. When you double click the preview image in the lower right corner, another window pops up giving you a preview of the cover page with the fields filled with the recipient's information.

Software Uninstallation

This section describes the following procedures:

- full uninstallation of the Companion Suite Pro software,
- uninstallation of the drivers only.

Uninstall the software from your PC

Turn your PC on. Open an account session with the administration rights.

Run the programs removal from the menu **START > ALL PROGRAMS > COMPANION SUITE > COMPANION SUITE PRO LL2 > UNINSTALL**.

- 1 A confirmation screen appears. Click on the **YES** button to continue the Companion Suite Pro program removal.

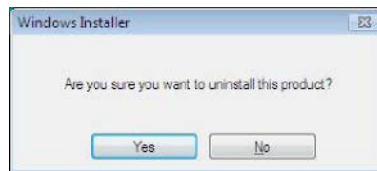

- 2 The uninstall program is launched. You can cancel the removal by clicking on **CANCEL**.

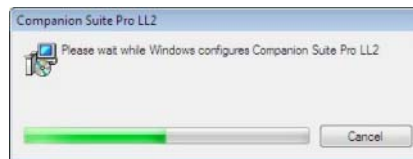

- 3 Click on the **OK** button.



- 4 You need to restart your system at the end of the procedure. Click on the **YES** button.



Uninstall the drivers from your PC

Turn your PC on. Open an account session with the administration rights.

Depending on the installation mode used, select the required uninstallation mode:

- If you have installed the drivers with the Companion Suite Pro software, see paragraph Uninstall the drivers using the Companion Suite Pro software.
- If you have installed the drivers manually, see paragraph Uninstall the drivers manually.

Uninstall the drivers using the Companion Suite Pro software

Run the programs removal from the menu **START > ALL PROGRAMS > COMPANION SUITE > COMPANION SUITE PRO LL2 > UNINSTALL**.



You can also uninstall **COMPANION SUITE PRO LL2** drivers using the Windows function **ADD/REMOVE PROGRAMS** from the control panel.

- 1 A confirmation screen appears. Click on the **YES** button to continue the **COMPANION SUITE PRO LL2** drivers program removal.



- 2 The uninstall program is launched. You can cancel the removal by clicking on **CANCEL**.

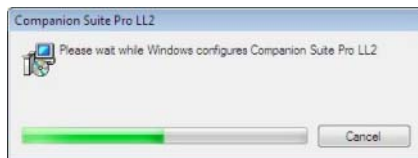

Uninstall the drivers manually

The following drivers must be removed:

- print driver
- scan driver
- modem driver

To remove the print driver:

- 1 Open the **PRINTERS** window (**START > CONTROL PANEL > PRINTERS AND FAXES** or **START > CONTROL PANEL > HARDWARE AND SOUND > PRINTERS**, depending on the operating system).
- 2 Delete the **LASER PRO LL2** icon.
- 3 In the **PRINTERS** window, right-click with the mouse and select **RUN AS ADMINISTRATOR > SERVER PROPERTIES**.
- 4 Select the **DRIVERS** tab.
- 5 Select the **LASER PRO LL2** driver and click on the **REMOVE** button.

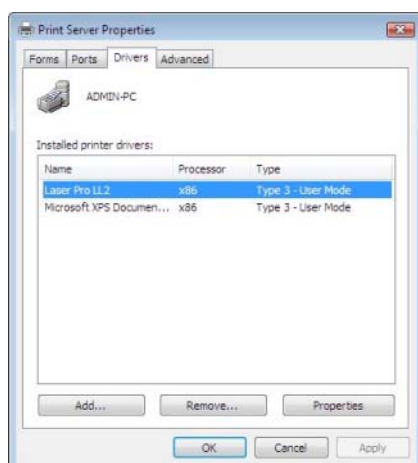

- 6 Select the option **REMOVE DRIVER AND DRIVER PACKAGE** and click on the **OK** button.



- 7 A confirmation screen appears. Click on the **YES** button to continue.
- 8 Click on the **DELETE** button to confirm the removal.



To remove scan and modem drivers:

- 1 Open the **DEVICE MANAGER** window (**START > CONTROL PANEL > SYSTEM > HARDWARE > DEVICE MANAGER** or **START > CONTROL PANEL > HARDWARE AND SOUND > DEVICE MANAGER**, depending on the operating system).

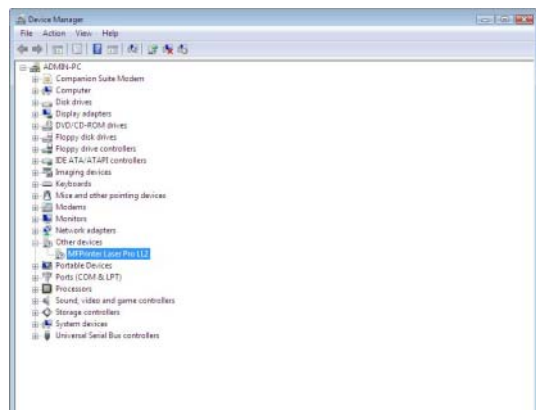

- 2 In the **OTHER DEVICES** sub-menu, select the **MF PRINTER LASER PRO LL2** item and click on the right button of the mouse.
- 3 Select **UNINSTALL** on the menu and left-click with the mouse.



- 4 Click on the **OK** button to confirm the removal.
- 5 In the **IMAGING DEVICES** sub-menu, select the **SCANNER PRO LL2** item and right-click with the mouse.
- 6 Select **UNINSTALL** on the menu and left-click with the mouse.
- 7 Click on the **OK** button to confirm the removal.

Maintenance

Service

General information



CAUTION

For your safety, it is imperative to refer to the safety information presented in chapter **Security**, page 1.

To ensure that your machine is kept in the best conditions, it is recommended that you periodically clean the inner parts.

Please respect the following rules while using this machine:

- Do not leave the scanner cover open.
- Do not try to lubricate the device.
- Do not close the scanner cover violently or do not apply vibrations to the machine.
- Do not open the cartridge access cover while printing.
- Do not try to disassemble the machine.
- Do not use paper which would have stayed in the tray for too long.

Toner cartridge replacement

Three toner cartridge replacement procedures can be used depending on the **TONER MANAGEMENT** setting.

- **TONER MANAGEMENT** setting set to **WITH [0-10%]** : the replacement of the cartridge can be performed only when the message **Toner near end** is displayed. At the end of replacement, validation with the smart card is required.
- **TONER MANAGEMENT** setting set to **WITH [0-100%]** : the replacement of the cartridge can be performed at any time. At the end of replacement, validation with the smart card is required.
- **TONER MANAGEMENT** setting set to **WITHOUT** : the replacement of the cartridge can be performed at any time and no validation with the smart card is necessary. When set to **WITHOUT**, the screen displays **TONER ? %**.

To set the **TONER MANAGEMENT** setting, select 6 **2979 - SETUP / TECHNICALS / TONER MANAGEMENT** and choose the setting.



CAUTION

This procedure applies when the setting **TONER MANAGEMENT** is set to **WITH [0-10%]**.

When set to **With [0-100%]**, follow the procedure from step 2.

When set to **WITHOUT**, follow the procedure from step 2 to step 7.

Your machine comes with a current consumable management system. It tells you if your toner cartridge is close to its end of cycle. The following message will appear on your machine screen.

**TONER NEAR
END**

To quit this screen, press **OK**.

To replace the toner cartridge, proceed as shown below.

When the following message is displayed on the screen:

**TONER EMPTY
REPLACE <OK>**

- 1 Press **OK**.

**OPEN FRONT COVER
REPLACE TONER**

- 2 Stand in front of the device.
- 3 Push on the left and right sides of the cover and pull it towards you.
- 4 Raise and remove the toner cartridge from the machine.
- 5 Unpack the new cartridge and insert it into the slot as indicated in the diagram below.

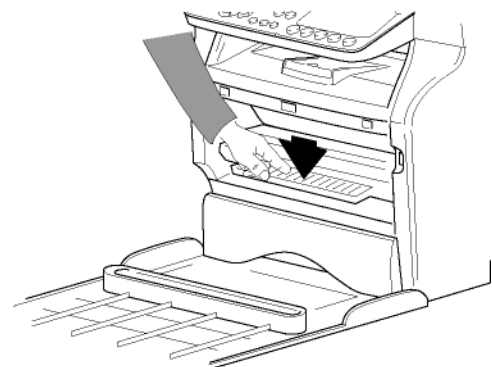
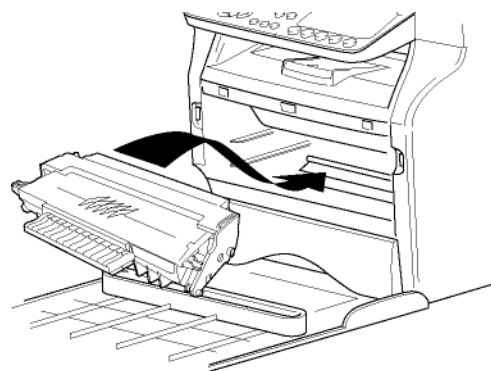

- 6 Close the cover.
The following message appears:

**HAVE YOU CHANGED
THE TONER? <OK>**

- 7 Press **OK**.

- 8 When this message appears,

**INSERT THE
TONER CARD**

insert the smart card provided with the new toner cartridge as shown on the picture below.

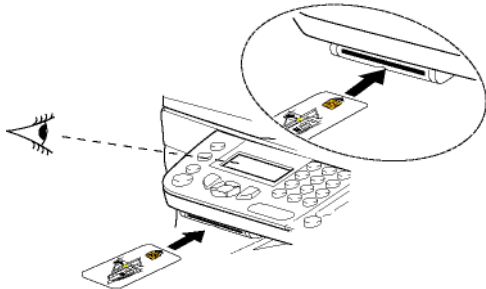

- 9 A wait message appears.

**PLEASE
WAIT**

The smart card is read.

**NEW TONER
REMOVE CARD**

Remove the smart card from the reader, your machine is ready to print again.



CAUTION

*To continue the printing of your documents when the message **TONER NEAR END is displayed, set the TONER MANAGEMENT setting to WITHOUT.***

***Caution :** this procedure is not recommended as disabling toner management (parameter set to **WITHOUT**) can lead to fax loss and toner being spilled in your print mechanism.*

Issues with smart cards

If you use a smart card that has already been used, the machine will display:

**PLEASE
WAIT**

then,

**REMOVE CARD
ALREADY USED**

If you use a defective smart card, the machine will display:

**PLEASE
WAIT**

then,

**UNKNOWN CARD
REMOVE CARD**

If the **C** button is pressed while the smart card is being read, the machine displays:

**ACTION CANCELLED
REMOVE CARD**

Cleaning

Scanner reading system cleaning

When one or more vertical lines appear on the copies, clean the glass of the scanner.

- 1 Open the scanner cover until it is standing in vertical position.
- 2 Wipe the glass with a soft lint-free cloth soaked with mild alcohol.
- 3 Close the scanner cover.
- 4 Make a copy to check that the symptoms have disappeared.

Printer cleaning

Dust, dirtiness and paper debris on the external and internal surfaces of the printer can affect its operation. We advise that it is cleaned regularly.

Printer external cleaning

Clean the external part of the printer with a soft cloth soaked in mild detergent.

Document-feeder roller cleaning

Clean the roller of the document feeder when:

- one or more vertical lines appear on the copies of documents placed on the document feeder (presence of debris, ink, glue, etc., in the paper transport mechanism).
- the message ****YOU SHOULD CLEAN THE ROLLER OF THE SCANNER FEEDER. PLEASE REFER TO USER MANUAL. PRESS <STOP> WHEN THE ROLLER IS CLEANED**** warns you that the document feeder cannot transport paper sheets anymore (dust, dirt or debris obstructing the rollers). Press **OK** to clear the message on the screen.

To clean the document feeder roller, proceed as shown below:

- 1 Press the On/Off button to turn off the device (0 position) and unplug the power cord.

- 2 Open the document-feeder scanner cover.

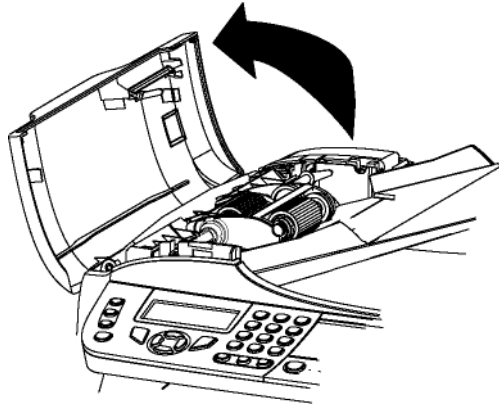

- 3 Clean the rollers of the document feeder and the two idler rollers located on the mobile part of the scanner with a soft lint-free cloth dampened with mild alcohol. To clean them, rotate them in the same direction as during paper transport.

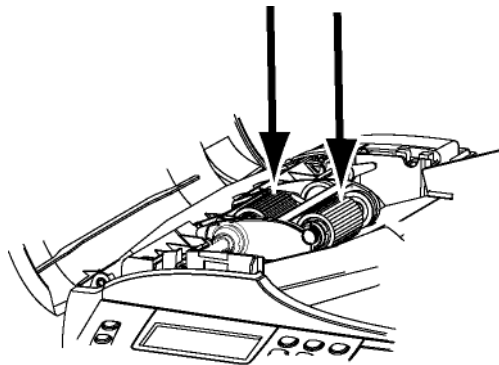

- 4 Wipe the rollers with a soft, dry lint-free cloth until they are dry.
- 5 Close the document-feeder scanner cover.
- 6 Plug the power cord to outlet on the wall and press the On/Off button to turn on the device (I position).
- 7 Make a copy to check that the symptoms have disappeared.

Printer issues

Error messages

When the printer encounters any of the problems described below, the corresponding message is shown on the machine display.

Message	Action
CHECK TONER	Check the presence of a toner cartridge in the machine.
TONER NEAR END	Indicates that your consumable will need changing soon.
REPLACE PAPER	Add paper in tray.
HEATING	Message displayed when starting the machine.
CLOSE COVER PRINTER	The printer front cover is open, close it.
TONER EMPTY REPLACE <ok>	Replace the toner cartridge.
PAPER JAM REMOVE TONER	A sheet of paper is jammed in the machine. Take out the toner cartridge and remove the jammed paper sheet. Take out the paper tray and remove the jammed paper sheet. Then open and close the Front cover.
PAPER JAM EXTERNAL TRAY	A sheet of paper is jammed in the machine. Open the paper jam cover. Remove the jammed paper sheet. Then open and close the Front cover.
PAPER EMPTY	Add paper in the paper tray.



Note

*After one of the error messages listed above is displayed, it may happen that the active print job is cancelled (see **PC printing issues**, page 65).*

In case of printing of received fax, the print job is always restarted after clearing of the error.

Paper jam

When printing, a sheet of paper may get stuck in the printer or the paper tray and cause a paper jam.

In case of a paper jam in the machine, the following message appears:

PAPER JAM EXTERNAL TRAY

- 1 Open the paper jam cover located at the back of the machine.
- 2 Remove the jammed sheet of paper and close the cover.

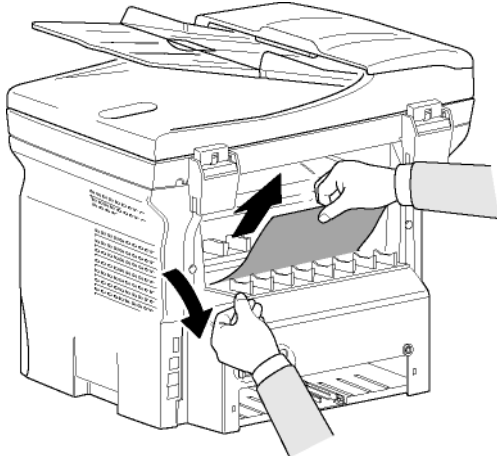

- 3 Open and close the Front cover.
The printer starts again automatically.



CAUTION

The fusion unit can reach a very high temperature during the operation. To prevent any harm, do not touch this area.

*For details, refer to **Positions of Warning and Caution labels on the machine**, page 3.*

In case of paper jam, the following message appears:

PAPER JAM REMOVE TONER

- 1 Remove the toner cartridge and check if a sheet is jammed.
- 2 Remove the sheet of paper which causes the paper jam.
- 3 Put the toner cartridge in the machine, or remove the paper tray and remove the sheet of paper which causes the paper jam.
- 4 Check that the paper sheets in the paper tray are correctly placed.

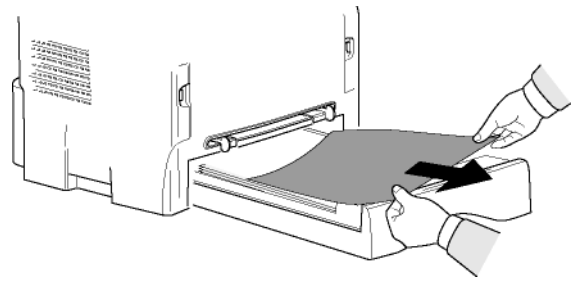

- 5 Replace the paper tray in the machine.

Scanner issues

When a paper jam occurs, the following message appears:

REMOVE DOCUMENT STOP TO CONFIRM

- 1 Open the document feeder scanner cover.

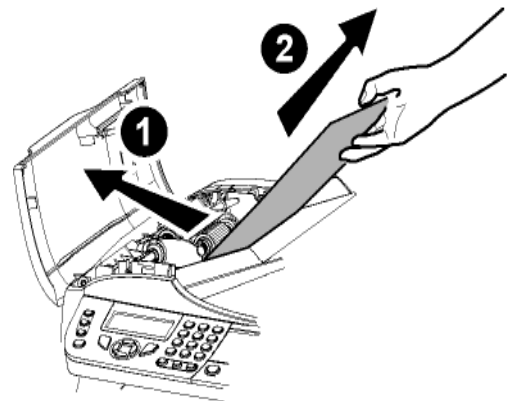

- 2 Remove the jammed paper without tearing it.
- 3 Close the document feeder scanner cover.

Miscellaneous issues

When turning on the terminal, nothing is displayed on the screen.

Check the connection between the power cord and the outlet.

The terminal does not detect the presence of the document inserted in the scanner document feeder. The message READY does not appear on the screen. At the start and during scanning, REMOVE DOCUMENT appears on the screen.

- 1 Remove the document or press button .
- 2 Check the thickness of the document (50 sheets of paper of 80 g/m²).
- 3 Iron out the sheets if needed.
- 4 Help the sheets along.

The terminal does not receive any faxes.

- 1 Check that the telephone line cable is correctly plugged in.

- 2 Check that there is a tone signal on the telephone line by means of the button .

You receive a blank page.

- 1 Make a photocopy of a document; if it is correct then your fax is functioning normally.
- 2 Call back the subscriber and have him resend the document. It was probably sent with the sheet inserted backwards.

You cannot send a fax.

- 1 Check that the telephone line cable is correctly plugged in.
- 2 Check the tone by pressing the button .
- 3 Check the prefix is correctly programmed and used.

Communication errors



If the communication fails, the terminal advises you of an automatic retry later.

Example of what is displayed:

Current time	FRI 12 DEC 20:13
Time of next try	0142685014 20:18

Transmission from the feeder

You have the choice between:

- waiting until the transmission takes place at the given time,
- restarting the transmission immediately by pressing ,
- abandoning transmission by pressing . To eject the document, press  again.

Transmission from memory

You have the choice between:

- waiting until the transmission takes place at the given time,
- restarting the transmission using the transmission queue. In this case, for a document composed of several pages, the transmission will take place from the page where the error occurred,
- abandoning the transmission by deleting the corresponding command in the transmission line.

The terminal makes at most 5 automatic redials. The non-transmitted document is automatically deleted from the memory and a transmission report is then printed together with an error code and the cause for transmission failure (see the communication error codes).

Communication error codes

The communication error codes appear in the logs and transmission reports.

General codes

Code 01 - Busy or no fax answer

This code appears after 6 unsatisfactory attempts. Call later.

Code 03 - User break

A communication has been stopped by the user pressing the button .

Code 04 - Non programmed number

A number saved as a One-Touch button or abbreviated number is not valid, check it. (Example: a delayed transmission was programmed with a One-Touch button and this button has been deleted in the meantime).

Code 05 - Scanning default

An incident occurred with the scanner, for example, the sheet is jammed.

Code 06 - Printer default

An incident occurred in the printer: no paper, paper jam, opened cover... In the reception mode, this incident appears only if the reception parameter is switched to **WITHOUT PAPER**.

Code 07 - Disconnected

The link has been cut (bad line). Check the number and try again.

Code 08 - Quality

The document you sent was not well received. Contact your subscriber to see if you need to send again.

Code 0A - No document to be polled

You tried to poll a document from a subscriber who had not prepared his document (no deposit) or the password entered was incorrect.

Code 0B - Wrong number of pages

Code 0C - Received document error

Ask the subscriber who called you to check the length of his document (it may be too long to be completely received).

Code 0D - Transmission failed

Ask the sender to resend the document.

Code 13 - Memory full

Your fax can no longer receive since its memory is full. There are too many received unprinted documents or too many documents in the transmission line.

Print the received documents and delete or transmit immediately the documents in the transmission line.

Code 14 - Memory full

Received document memory full.

Code 19 - Subscriber has stopped

The communication has been stopped by your subscriber. (Example: a fax wanted to poll your fax but there is no document deposited).

Code 1A - Disconnected

The transmission has not started. The telephone line is busy.

Code 1B - Transmission failed

During transmission: start again.

During reception: ask your subscriber to resend the document.

PC printing issues

This section details how the machine handles a print request after having encountered an issue (paper jam, connection loss, etc.).

Refer to the sections below to know if the printing of your document will resume or will be cancelled, depending on the problem encountered during printing.

PC printing via USB connection

Issue encountered	Print request handling
Paper empty	Once the problem is resolved, printing resumes from the first non-printed page.
No paper feed	Once the problem is resolved, printing resumes from the first non-printed page.
Paper jam	
Paper format problem	Exception: If the document was to be printed in manual duplex mode, the printing of the document is cancelled.
Toner empty	The printing of the active document is cancelled. Documents waiting to be printed, however, will print after the toner cartridge is replaced.
Pause requested from the spooler	The machine switches to idle mode after a timeout (30 seconds by default). The printing of the active document is cancelled. Documents waiting to be printed, however, will be printed.
Loss of USB connection	Once the problem is resolved, the printing of the document restarts from the beginning, regardless of the number of pages already printed before the connection loss.

Firmware update

Updating the machine firmware requires that the Companion Suite Pro software be installed on your PC, and that the PC is connected to the machine (see **PC Features**, page 41).

Contact your Dealer to check if firmware updates are available for your machine.

Then, access the update utility (**START > ALL PROGRAMS > COMPANION SUITE > COMPANION SUITE PRO LL2 > COMPANION - FIRMWARE UPDATE**), select the downloaded file and launch the update.

Specifications

Physical specifications

Dimensions:	412 x 447 x 386 mm
Weight:	13 kg

Electrical specifications

Power supply (see rating plate):	Single phase 220-240 V - 50/60 Hz - 4.5 A
Electric consumption:	12 W typical in powersave 35 W typical in standby 450 W average during printing (900W peak)

Environmental specifications

Operating temperature:	10 °C to 27 °C [50 °F to 80.6 °F] with an ambient humidity included between 15 to 80% (up to 32°C [89.6 °F] with an ambient humidity included between 15 to 54%)
------------------------	--

Peripheral specifications

Printer

Type:	Laser (on normal paper)
Resolution:	600 dpi
Speed:	20 ppm maximum ^a
Preheating time:	21 sec.
First page out time:	13 sec.

- a. Printing speed may vary depending on used operating systems, computer specifications, software applications, paper formats as well as file types and sizes.

Copier

Type:	Autonomous Black and White
Copy speed:	20 ppm maximum
Resolution:	600 dpi
Multiple copies:	99 pages maximum
Zoom range:	25 % to 400 %

Scanner

Type:	Colour scanner
Document feeder capacity:	50 sheets
Colour depth:	36 bits
Resolution:	600 dpi (optical) 2400 dpi (interpolated)
Software compatibility:	TWAIN, WIA
Maximum paper format:	Letter

Printing supports

Main paper tray capacity:	250 sheets maximum (60 g/m ²), 200 sheets maximum (80 g/m ²)
Output tray capacity:	50 sheets
Main tray paper format:	A4, A5, Legal, Letter 60 to 105 g/m ² paper
Paper format for manual printing:	A4, A5, Legal, Letter, B5, exec, A6 52 to 160 g/m ² paper

PC connection

Slave USB 2.0 port (PC connection)
Master USB 2.0 port (reader, USB memory key reader)
Operating System: Windows 2000 ≥ SP4, Windows XP x86 ≥ SP1, Windows Vista, Windows 2003 server (for printing only)
Specifications are subject to changes for improvement without notice.