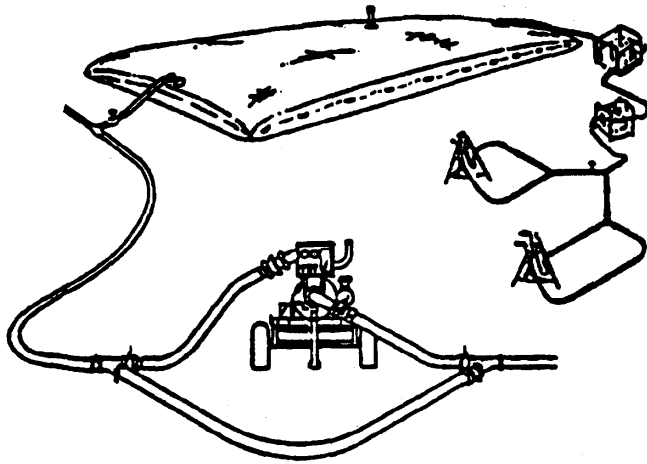


TECHNICAL MANUAL
OPERATOR'S, UNIT AND DIRECT SUPPORT
MAINTENANCE MANUAL
TABLE OF CONTENTS



TACTICAL WATER DISTRIBUTION
EQUIPMENT
SYSTEM (TWDS) SET 10-MILE SEGMENT,
MODELS 06749-0183-81, 110-00-0000,
919 AND 10
NSN 4320-01-122-3547
NSN 4320-01-168-0591
NSN 4320-01-168-0590
NSN 4320-01-221-6006

EQUIPMENT DESCRIPTION

OPERATING INSTRUCTIONS

OPERATOR PREVENTIVE MAINTENANCE
CHECKS AND SERVICES

OPERATOR MAINTENANCE PROCEDURES

UNIT MAINTENANCE PREVENTIVE
CHECKS AND SERVICES

UNIT MAINTENANCE PROCEDURES

DIRECT SUPPORT MAINTENANCE
PROCEDURES

MAINTENANCE ALLOCATION CHART

INDEX

DISTRIBUTION STATEMENT A: Approved for public release; distribution is unlimited.

* This manual, together with TM 10-4320-344-10, TM 10-4320-344-24 and LO 10-4320-344-12 supersede TM 5-4320-303-10, dated 14 April 1986 and TM 5-4320-303-24, dated 13 June 1986.

HEADQUARTERS, DEPARTMENT OF THE ARMY
30 JUNE 1993

CHANGE
NO. 1

HEADQUARTERS
DEPARTMENT OF THE ARMY
WASHINGTON, D.C., 19 August 1996

Operator's, Unit, and Direct Support
Maintenance Manual

**TACTICAL WATER DISTRIBUTION EQUIPMENT
SYSTEM (TWDS) SET 10-MILE SEGMENT,
MODEL 06749-0183-81, 110-00-0000, 919 AND 10
(NSN 4320-01-122-3547; NSN 4320-01-168-0591;
NSN 4320-01-168-0590; NSN 4320-01-221-6006)**

DISTRIBUTION STATEMENT A: Approved for public release; distribution is unlimited

TM 10-4320-303-13, 30 June 1993, is changed as follows:

1. Remove and insert pages as indicated below. New or changed text material is indicated by a vertical bar in the margin. An illustration change is indicated by a miniature pointing hand.

Remove pages

Insert pages

i and ii
1-9 and 1-10

i and ii
1-9 and 1-10

2. Retain this sheet in front of manual for reference purposes.

By Order of the Secretary of the Army:

DENNIS J. REIMER
General, United States Army
Chief of Staff

Official:

JOEL B. HUDSON
Administrative Assistant to the
Secretary of the Army
02186

DISTRIBUTION:

To be distributed in accordance with DA Form 12-25-E, block no. 6077, requirements for TM 10-4320-303-13.

WARNING

Do not stand under load being lifted.

Do not allow sand or grit to contaminate chlorine solution.

Calcium hypochlorite can cause injury if not handled properly.

- Do not use calcium hypochlorite without proper clothing. Wear goggles, rubber gloves, and apron to protect eyes and skin. Wash exposed skin thoroughly.
- If calcium hypochlorite comes into contact with skin or eyes, flush right away with water and seek medical attention.
- Store calcium hypochlorite in a cool dry place. Keep container closed.
- Mix calcium hypochlorite only in accordance with directions.
- Do not allow calcium hypochlorite to mix with other chemicals, such as fuels, oils, paint products, or ammonia. This could cause fire or hazardous gas.

Hearing protection must be worn by personnel within 50 meters of an operating 600 GPM pumping assembly.

Ensure 600 GPM pumping assemblies are shutdown prior to performing maintenance on 6 inch hoseline segments. Failure to shutdown 600 GPM pumping assemblies will result in excessive water pressure in 6 inch hoseline segment.

Components of hypochlorinator assembly, main valve assembly, and pressure regulating valve are under spring pressure. Maintain pressure on covers when removing covers during maintenance activities on these items.

Do not work on equipment that is not securely stabilized to prevent sliding.

Dry cleaning solvent, PD-680, used to clean parts is potentially dangerous to personnel and property. Avoid repeated or prolonged skin contact. Do not use near open flame or excessive heat. Flash point of solvent is 100-138 degrees Fahrenheit (38-600 C).

Do not use petroleum based lubricants for installation of o-rings and gaskets.

Failure to obey these warnings may result in serious injury or death to individuals or personnel.

FOR FIRST AID, SEE FM 21-11.

a/(b Blank)

TECHNICAL MANUAL

NO. 10-4320-303-13

HEADQUARTERS
DEPARTMENT OF THE ARMY
WASHINGTON D.C., 30 June 1993

**Operator's, Unit, and Direct Support
Maintenance Manual
TACTICAL WATER DISTRIBUTION EQUIPMENT
SYSTEM (TWDS) SET 10-MILE SEGMENT,
MODEL 06749-0183-81, 110-00-0000, 919 AND 10
(NSN 4320-01-122-3547; NSN 4320-01-168-0591;
NSN 4320-01-168-0590; NSN 4320-01-221-6006)**

REPORTING ERRORS AND RECOMMENDING IMPROVEMENTS

You can help improve this manual if you find any mistakes, or if you know of a way to improve these procedures, please let us know. Mail your letter or DA Form 2028 (Recommended Changes to Publications and Blank Forms), or DA Form 2028-2 located in the back of this manual directly to: Commander, US Army Aviation and Troop Command, AITN: AMSAI-I-MP, 4300 Goodfellow Blvd. St. Louis, MO 63120-1798. You may also submit your recommended changes by E-mail directly to <mpmt%avma2g8st-louis-emh7.army.mil>. A reply will be furnished directly to you. Instructions for sending an electronic 2028 may be found at the back of this manual immediately preceding the hard copy 2028.

Distribution Statement A. Approved for public release; distribution is unlimited.

TABLE OF CONTENTS

	Page
HOW TO USE THIS MANUAL	vii
CHAPTER 1 INTRODUCTION.....	1-1
Section I. General Information	1-1
Section II. Equipment Description	1-3
Section III. Principles of Operation	1-15
CHAPTER 2 OPERATING INSTRUCTIONS	2-1
Section I. Description and Use of Operator's Controls and Indicators.....	2-2
Section II. Operator Preventive Maintenance Checks and Services (PMCS)	2-8
Section III. Operation Under Usual Conditions.....	2-30
Section IV. Operation Under Unusual Conditions.....	2-114

This manual, together with TM 10-4320-344-10, TM 10-4320-344-24 and LO 10-4320-344-12 supersede TM 5-4320-303-10 dated 14 April 1986 and TM 5-4320-303-24 dated 13 June 1986.

TABLE OF CONTENTS - CONTINUED

	Page
CHAPTER 3	OPERATOR MAINTENANCE INSTRUCTIONS 3-1
Section I.	Lubrication Instructions 3-1
Section II.	Operator Troubleshooting Procedures 3-1
Section III.	Operator Maintenance Procedures 3-5
CHAPTER 4	UNIT MAINTENANCE INSTRUCTIONS 4-1
Section I.	Repair Parts; Special Tools; Test, Measurement, and Diagnostic Equipment (TMDE); and Support Equipment 4-1
Section II.	Service Upon Receipt 4-2
Section III.	Unit Preventive Maintenance Checks and Services (PMCS) 4-9
Section IV.	Unit Troubleshooting 4-10
Section V.	Unit Maintenance Procedures 4-13
Section VI.	Preparation for Shipment and Storage 4-71
CHAPTER 5	DIRECT SUPPORT MAINTENANCE 5-1
Section I.	Repair Parts; Special Tools; Test, Measurement, and Diagnostic Equipment (TMDE); and Support Equipment 5-2
Section II.	Direct Support Maintenance Procedures 5-3
APPENDIX A	REFERENCES A-1
APPENDIX B	MAINTENANCE ALLOCATION CHART B-1
Section I	Introduction B-1
Section II	Maintenance Allocation Chart B-4
Section III	Tool and Test Equipment Requirements B-7
Section IV	Remarks B-8
APPENDIX C	COMPONENTS OF END ITEM (COEI) AND BASIC ISSUE ITEMS (BII) LISTS C-1
Section I	Introduction C-1
Section II	Components of End Item C-2
Section III	Basic Issue Items C-35
APPENDIX D	ADDITIONAL AUTHORIZED ITEMS LIST (AAL) D-1

TABLE OF CONTENTS - CONTINUED

		Page
APPENDIX E	EXPENDABLE AND DURABLE ITEMS LIST	E-1
Section I	Introduction	E-1
Section II	Expendable Durable Items List.....	E-2
APPENDIX F	ILLUSTRATED LIST OF MANUFACTURED ITEMS.....	F-1
APPENDIX G	TORQUE LIMITS	G-1
GLOSSARY.....	GLOSSARY-1
Section I	Abbreviations	GLOSSARY-1
Section II	Definition of Unusual Terms	GLOSSARY-1
INDEX	INDEX-1

LIST OF ILLUSTRATIONS

Figure	Title	Page
1-1	Tactical Water Distribution Equipment System (TWDS) Set 10-Mile Segment	1-0
1-2	Location of Major Components for TWDS Lead Pumping Station.....	1-4
1-3	Location of Major Components for TWDS 10-Mile Hoseline Segment	1-5
1-4	Location of Major Components for TWDS Boost Pumping Station	1-6
1-5	Location of Major Components for TWDS Storage Assembly.....	1-7
1-6	Location of Major Components for TWDS Distribution Point.....	1-8
1-7	Major Support Components for TWDS	1-10
1-8	Suspension Kit and Displacement and Evacuation Kit.....	1-11
1-9	Packing Kit and Repair Kit.....	1-12
2-1	Operator's Controls and Indicators for TWDS Lead Pumping Station	2-2
2-2	Operator's Controls and Indicators for TWDS 10-Mile Hoseline Segment.....	2-3
2-3	Operator's Controls and Indicators for TWDS Boost Pumping Station	2-4
2-4	Operator's Controls and Indicators for TWDS Storage Assembly.....	2-5
2-5	Operator's Controls and Indicators for TWDS Distribution Point	2-6
2-6	Operator's Controls and Indicators for Hypochlorination Unit, Model 1955-1	2-7
2-7	Operator PMCS Routing Diagram	2-10
2-8	Ground Profile.....	2-32
2-9	Pump Spacing Triangle	2-33
2-10	First Boost Pumping Station Location.....	2-34
2-11	Pressure-Reducing Valve Assembly Location.....	2-35
2-12	Grooved Pipe Coupling	2-37
2-13	Grooved-End Pipe Quick Disconnect Coupling Clamp	2-38
2-14	Lead Pumping Station Suction Port and Butterfly Valve Assembly (Model 609-A Shown)	2-41
2-15	Lead Pumping Station Discharge Port and TWDS Components Assembly.....	2-41
2-16	Pressure Relief Valve Installation.....	2-42
2-17	TWDS Water Source Connection Components Assembly	2-43
2-18	Boost Pumping Station and Suction Components Assembly.....	2-45
2-19	Boost Pumping Station and Discharge Components Assembly.....	2-46
2-20	Boost Pumping Station and Bypass Components Assembly	2-47
2-21	Storage Assembly Connection Components Assembly	2-49
2-22	Final Assembly of Storage Assembly	2-50
2-23	Hypochlorination Unit and 125 GPM Pump Installation.....	2-53
2-24	Hypochlorination Unit Model 1955-1 and Model A-506131 Installation.....	2-56
2-25	Distribution Point Assembly.....	2-57
2-26	Hypochlorination Unit	2-60
2-27	Tripod Stand Assembly	2-60
2-28	Tripod and Water Storage Drinking Bag	2-61
2-29	10-Mile Hoseline Segment Installation.....	2-62
2-30	Loading and Securing Flaking Boxes	2-64
2-31	Tailgate Assembly Removal.....	2-65
2-32	Positioning Breakaway on Flaking Box Assembly.....	2-66
2-33	Breakaway Installation	2-67
2-34	Grooved Pipe Coupling and Swivel Joint Installation	2-68
2-35	Connection to Lead Pumping Station	2-69
2-36	Swivel Joint Connection	2-70
2-37	Road Crossing Guard Installation	2-70
2-38	Tripods and Wire Rope Installation.....	2-71
2-39	Securing Wire Rope	2-72
2-40	Saddle Installation.....	2-73
2-41	Hoseline Installation	2-74
2-42	Pressure-Reducing Valve Assembly Installation	2-74
2-43	20,000 Gallon Pillow Tank Fill-up	2-77
2-44	Sandbag Installation.....	2-78
2-45	Hypochlorination Unit Model 1955-1 Controls and Suction Foot	2-80
2-46	Hypochlorination Unit Model 1955-1 Control and Water Meter	2-81
2-47	Stroke Adjust Thimble Operation.....	2-82
2-48	Correcting Air-Bound Unit After Startup.....	2-83
2-49	Install Chlorine Color Disc	2-84

LIST OF ILLUSTRATIONS - CONTINUED

Figure	Title	Page
2-50	Installation of Prism Eyepiece	2-84
2-51	Preparation of Sample Cells.....	2-85
2-52	Viewing Water Samples	2-85
2-53	pH Indicator	2-87
2-54	Hypochlorination Unit, Model 1955-1 "CAUTION" Plate	2-88
2-55	Ball Receiver Installation.....	2-91
2-56	Pneumatic Coupler Installation.....	2-92
2-57	End Cap Installation	2-93
2-58	Collapsing Hoseline.....	2-93
2-59	Flaking Box Assembly Preparation.....	2-94
2-60	Pullboard Flange and Coupling Sleeve Installation.....	2-95
2-61	Start Hoseline Packing	2-96
2-62	Compress Hoseline	2-97
2-63	Hose Retaining Bracket Installation	2-98
2-64	Tailgate Assembly Installation.....	2-99
2-65	Disassembly of Suspension Device	2-100
2-66	Disassembly of Road Crossing Guard	2-102
2-67	Disassembly of Pressure-Reducing Valve Assembly	2-102
2-68	Disassembly of Lead Pumping Station (Suction Port).....	2-103
2-69	Disassembly of Lead Pumping Assembly (Discharge Port).....	2-104
2-70	Disassembly of Boost Pumping Station (Suction Port).....	2-105
2-71	Disassembly of Boost Pumping Station (Discharge Port).....	2-106
2-72	Disassembly of Bypass Hose	2-107
2-73	Disassembly of Storage Assembly Components.....	2-108
2-74	Disconnecting 20,000 Gallon Pillow Tank.....	2-109
2-75	Cleaning of 36 Gallon Drinking Water Storage Bag	2-110
2-76	Disassembly of Model 1955-1 Hypochlorination Unit	2-110
2-77	Disassembly of Distribution Point	2-111
2-78	Flushing of Hypochlorination Unit (Model 1955-1 Shown).....	2-112
2-79	Removal of 125 GPM Pumping Assembly and Hypochlorination Unit	2-113
3-1	Hose Clamp Installation	3-6
3-2	Damaged Hose Section Removal.....	3-6
3-3	Male Quick-Disconnect Coupling Half and Banding Installation	3-7
3-4	Strapping Preparation	3-7
3-5	Preparing Banding Tool for Use	3-8
3-6	Tightening Strapping	3-9
3-7	Rolling of Banding Tool.....	3-9
3-8	Removing Banding Tool.....	3-10
3-9	Securing Buckle and Strapping	3-10
3-10	Spacing of Buckles on Repaired 6-Inch Hose Assembly.....	3-11
3-11	Repaired Hose Connection.....	3-11
3-12	Doubled-Ended Adapter Installation	3-12
4-1	Reducer Y-Connection Removal	4-13
4-2	Reducer Y-Connection Disassembly	4-14
4-3	6 Inch Butterfly Valve Assembly Removal.....	4-16
4-4	6 Inch Butterfly Valve Assembly Disassembly	4-17
4-5	Hose Assembly Replacement.....	4-19
4-6	6 Inch x 500 Foot Collapsible Hose Assembly Replacement	4-21
4-7	Flaking Box Assembly Maintenance	4-22
4-8	Swivel Joint Replacement.....	4-24
4-9	Pressure-Reducing Valve Assembly Replacement	4-26
4-10	Pressure-Reducing Valve Assembly Maintenance.....	4-28
4-11	Pressure-Reducing Valve Assembly Tubing and Pressure-Reducing Control Maintenance.....	4-29
4-12	Pressure Relief Valve Assembly Maintenance.....	4-33
4-13	4 Inch Gate Valve Assembly Maintenance	4-36
4-14	Hypochlorination Unit, Model 1955-1 Replacement	4-38
4-15	Outlet Hose Assembly Maintenance	4-39
4-16	Pressure Gauge and Fill Assembly Maintenance.....	4-41
4-17	Strainer Maintenance	4-43
4-18	Water Meter and Gear Box Assembly Replacement.....	4-45
4-19	Hypochlorinator Assembly Maintenance	4-48

LIST OF ILLUSTRATIONS - CONTINUED

Figure	Title	Page
4-20	Manifold Assembly Maintenance	4-50
4-21	Chlorine Reservoir and Tool Box Replacement	4-54
4-22	Stand Assembly Maintenance	4-55
4-23	Color Comparator Maintenance	4-57
4-24	Suspension Kit Components	4-59
4-25	Displacement and Evacuation Kit Components	4-61
4-26	Packing Kit Components	4-63
4-27	Hose Retaining Bracket Maintenance	4-65
4-28	Repair Kit Components	4-67
4-29	Sling Assembly Maintenance	4-69
5-1	Pressure-Reducing Control Maintenance.....	5-4
5-2	Main Valve Assembly Maintenance	5-7
5-3	Pilot Valve Assembly Maintenance	5-12
5-4	Gear Box Maintenance.....	5-15
5-5	Water Meter Maintenance	5-18
5-6	Pressure Regulating Valve Maintenance	5-20

LIST OF TABLES

Number	Title	Page
1-1	Nomenclature Cross-Reference List	1-2
1-2	Description of Major Components for TWDS Lead Pumping Station	1-4
1-3	Description of Major Components for TWDS 10-Mile Hoseline Segment.....	1-6
1-4	Description of Major Components for TWDS Boost Pumping Station	1-6
1-5	Description of Major Components for TWDS Storage Assembly	1-7
1-6	Description of Major Components for TWDS Distribution Point	1-9
1-7	Description of Major Support Components for TWDS.....	1-10
1-8	Description of Suspension Kit and Displacement and Evacuation Kit	1-11
1-9	Description of Packing Kit and Repair Kit	1-12
1-10	Differences Between Models.....	1-13
2-1	Description of Operator's Controls and Indicators for TWDS Lead Pumping Station	2-2
2-2	Description of Operator's Controls and Indicators for TWDS 10- Mile Hoseline Segment.....	2-3
2-3	Description of Operator's Controls and Indicators for TWDS Boost Pumping Station	2-4
2-4	Description of Operator's Controls and Indicators for TWDS Storage Assembly.....	2-5
2-5	Description of Operator's Controls and Indicators for TWDS Distribution Point.....	2-6
2-6	Description of Operator's Controls and Indicators for Hypochlorination Unit, Model 1955-1.....	2-8
2-7	Operator Preventive Maintenance Checks and Services for TWDS	2-15
2-8	Components Required from Pumping Station Crate for Assembly of Lead Pumping Station.....	2-40
2-9	Components Required from 10-Mile Segment Crate for Assembly of Lead Pumping Station.....	2-40
2-10	Components Required from Pumping Stations Crate for Assembly of Boost Pumping Station	2-44
2-11	Components Required from Storage Assembly Crate for Assembly of Storage Assembly.....	2-48
2-12	Components Required from Distribution Point Crate for Assembly of Distribution Points	2-51
2-13	Components Required from 10-Mile Segment Crate for Assembly of 10-Mile Hoseline Segment	2-64
2-14	Hypochlorite Solution Strength Index	2-79
3-1	Operator Troubleshooting Table.....	3-2
4-1	Pumping Station Crate	4-4
4-2	Storage Assembly Crate.....	4-4
4-3	Distribution Point Crate	4-5
4-4	10-Mile Segment Crate	4-6
4-5	Hose Assembly, 6 Inch, 500 Feet Crates.....	4-8
4-6	Unit Preventive Maintenance Checks and Services (PMCS)	4-10
4-7	Unit Troubleshooting Table	4-11

HOW TO USE THIS MANUAL

DESCRIPTION OF THE MANUAL.

Manual Organization. This manual is designed to help you operate and maintain the TWDS. Read the warning pages located in the front of the manual before operating or doing maintenance on the equipment.

The front cover of this manual provides an index that lists subjects that are commonly used. Each item indexed on the front cover has a black box at the edge of the cover. There is a corresponding black box on the first text page for each subject listed on the cover index.

The Table of Contents is provided for quick reference to the subjects covered by each chapter, section, and appendix. Chapters 2 through 6 also have a subject index that lists the major paragraphs in alphabetical order under the section title.

The major elements of this manual are its chapters and appendixes. The chapter and appendixes can be divided into one or more sections. This manual has six chapters and seven appendixes.

A glossary follows the last appendix. The glossary lists and explains the special or unique abbreviations and the unusual terms used in this manual.

An alphabetical index follows the glossary. That index is for use in locating specific items of information.

Locating a Malfunction. Finding the cause of a malfunction, troubleshooting, is the first step in fixing the equipment and returning it to operation. Follow these simple steps to determine the root of the problem:

- a. Turn to the Table of Contents in the manual.
- b. Locate "Troubleshooting" under the chapter that covers your level of maintenance. Turn to the page indicated.

Preparing for a Task. Be sure that you understand the entire maintenance procedure before beginning any maintenance task. Make sure that all parts, materials, and tools are handy. Read all steps before beginning. Prepare to do the task as follows:

- a. Carefully read the entire task before starting. It tells you what you will need and what you have to know to start the task.
- b. Obtain all listed equipment, tools, and parts.

How to do the Task. Read the entire task. Be sure that you understand the entire procedure. Perform the task. Be sure to obey all WARNINGS and CAUTIONS.

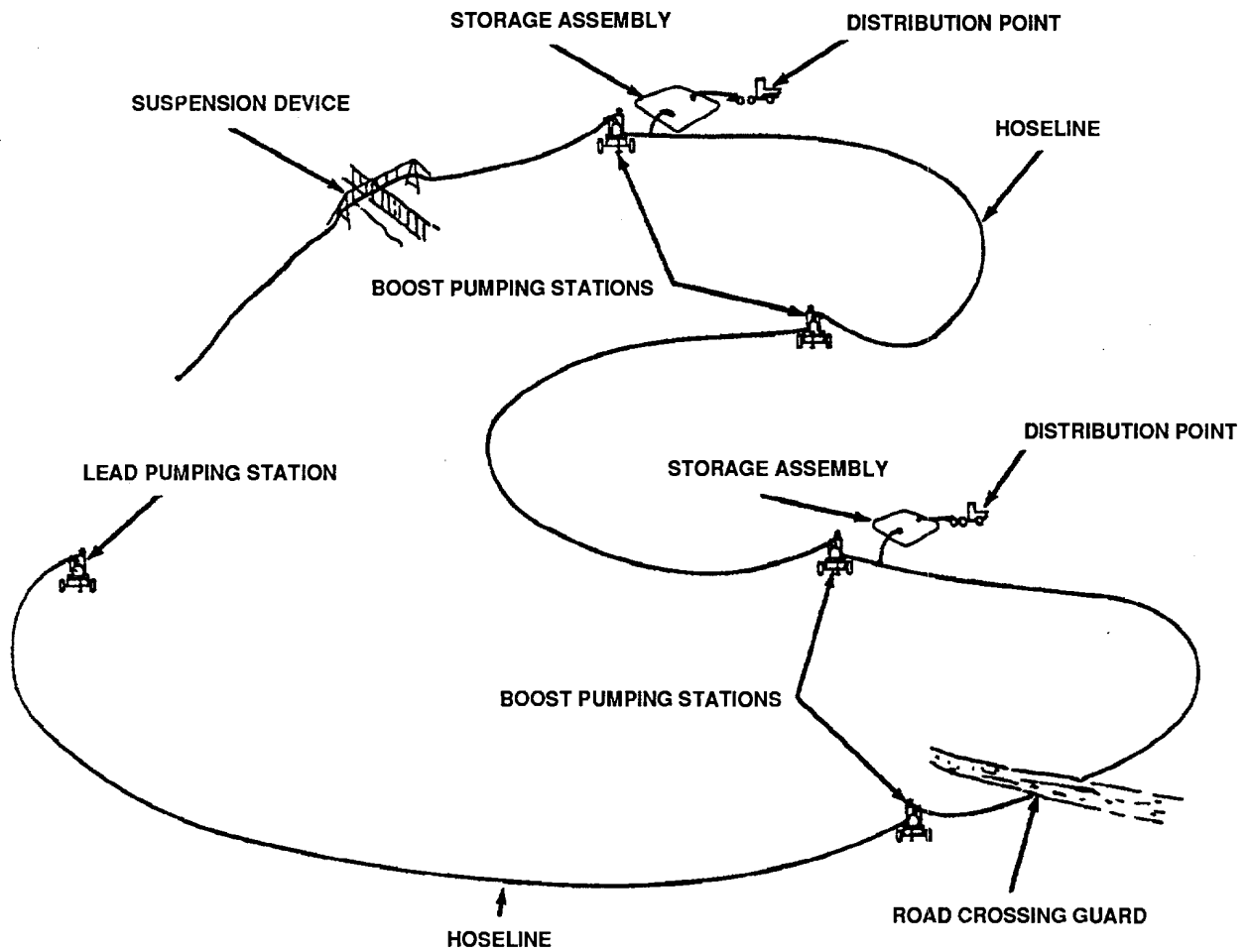


Figure 1-1. Tactical Water Distribution Equipment System (TWDS) Set 10-Mile Segment.

CHAPTER 1
INTRODUCTION
SECTION I. GENERAL INFORMATION

1.1 SCOPE.

This manual is for your use in operating and maintaining the Tactical Water Distribution Equipment System (TWDS) Set 10-Mile Segment models 06794-0183-81 (NSN 4320-01-122-3547), 110-00-0000 (NSN 4320-01-168-0591), 919 (NSN 4320-01-0590), and 10 (NSN 4320-01-221-6006). All four models of the TWDS perform the same function. The TWDS is depicted in Figure 1-1. This manual covers general information needed by the operator, descriptions of the TWDS, functional descriptions of how the TWDS works, operating instructions, operator maintenance instructions, unit maintenance instructions, direct support maintenance instructions, and general support maintenance instructions for the equipment. The TWDS receives water from large storage and distribution units, water purification units, host nation support, or additional TWDS. The TWDS transports this water to small distribution points, additional TWDS, or large storage and distribution units. The TWDS is capable of transporting up to 720,000 (seven-hundred twenty thousand) gallons of water in a 24 hour period. The TWDS is not intended for use with brackish or contaminated water or at temperatures below 320 F (0° C).

1.2 MAINTENANCE FORMS, RECORDS AND REPORTS.

Department of the Army forms and procedures used for equipment maintenance will be those prescribed by (as applicable) DA Pam 738-750, The Army Maintenance Management System (TAMMS) (Maintenance Management Update); DA Pam 738-751, Functional Users Manual for the Army Maintenance Management System-Aviation (TAMMS-A); or AR 700-138, Army Logistics Readiness and Sustainability.

1.3 DESTRUCTION OF ARMY MATERIEL TO PREVENT ENEMY USE.

Destruction of Army materiel to prevent enemy use shall be in accordance with TM 750-244-3.

1.4 PREPARATION FOR STORAGE OR SHIPMENT.

Reference paragraph 4.19 through 4.23 for instruction for the preparation for storage or shipment of the TWDS.

1.5 QUALITY ASSURANCE (QA).

There are no QA procedures applicable to the equipment covered in this technical manual.

1.6 NOMENCLATURE CROSS-REFERENCE.

Shortened nomenclature is used in this manual to make procedures easier for you to read. A cross-reference between the shortened nomenclature and the official nomenclature is shown in Table 1-1.

Table 1-1. Nomenclature Cross-Reference List.

Common Nomenclature	Official Nomenclature
125 GPM Pumping Assembly	Pump, Centrifugal; Frame MTD, 2 Inch 125 GPM, 50 Foot Head
600 GPM Pumping Assembly (Assemblies)	Pumping Assembly, Water, 600 GPM, Model 609-A, Model 609-C, and Model US636HCCD-1
20,000 Gallon Pillow Tank Hypochlorination Unit, Model 1955-1	20,000 Gallon Collapsible Fabric Tank Water Purification Hypochlorination Unit, Frame-Mounted, Automatically Controlled, 100 GPM, Model 1955-1
Hypochlorination Unit, Model 1955-3	Water Purification Hypochlorination Unit, Frame-Mounted, Automatically Controlled, 350 GPM, Model 1955-3
Hypochlorination Unit, Model A-506131	Hypochlorination Unit, Water Purification, Frame Mounted, Water Driven, 100 GPM
Water Storage Bag	Bag, Water Sterilizing

1.7 EQUIPMENT IMPROVEMENT RECOMMENDATION (EIR).

If your TWDS needs improvement, let us know. Send us an EIR. You, the user, are the only one who can tell us what you don't like about your equipment. Let us know why you don't like the design or performance. Put it on Standard Form (SF) 368 (Product Quality Deficiency Report). Mail it to us at Commander, U.S. Army Aviation And Troop Command, ATTN: AMSAT-I-MDO, 4300 Goodfellow Boulevard, St. Louis, MO 63120-1798. We will send you a reply.

1.8 WARRANTY INFORMATION.

The TWDS is not a warranted system.

1.9 SAFETY, CARE, AND HANDLING.

WARNING and CAUTION statements have been strategically placed throughout this manual prior to operating or maintenance procedures, practices, or conditions considered essential to the protection of personnel (WARNING) or equipment or property (CAUTION). Prior to the performance of any task read and understand all WARNINGS and CAUTIONS pertaining to the task at hand. Failure to do so may result in personnel injury, damage to equipment, or both.

1.10 CORROSION PREVENTION AND CONTROL (CPC).

Corrosion Prevention and Control (CPC) of Army materiel is a continuing concern. It is important that any corrosion problems with this item be reported so that the problem can be corrected and improvements can be made to prevent the problem in future items.

While corrosion is typically associated with the rusting of metals, it can also include deterioration of other materials, such as rubber and plastic. Unusual cracking, softening, swelling, or breaking of these materials may be a corrosion problem.

If a corrosion problem is identified, it can be reported using Standard Form 368, Product Quality Deficiency Report. Use of key words such as "corrosion," "rust," "deterioration," or "cracking" will ensure that the information is identified as a CPC problem. The form should be submitted to the address specified in DA PAM 738-750.

1.11 CALIBRATION.

The TWDS does not contain equipment which requires calibration.

1.12 LIST OF ABBREVIATIONS.

All abbreviations, acronyms, signs, and symbols used in this manual and not listed in MIL-STD-12 are listed in the Glossary located in the back of the manual.

1.13 GLOSSARY.

All terms used in this manual that are not defined in the text or listed in the Army Dictionary (AR 310-25) are defined in the glossary located in the back of the manual.

SECTION II. EQUIPMENT DESCRIPTION

1.14 EQUIPMENT CHARACTERISTICS, CAPABILITIES, AND FEATURES.

1.14.1 Characteristics. The TWDS consists of five or six pumping stations, a 10-mile hoseline segment, two storage assemblies, and two distribution points. The number of pumping stations is dependent on the terrain and distance over which the water must be transported. Smooth terrain requires five pumping stations with the sixth pumping station used as a spare. Rough terrain requires six pumping stations. Each pumping station consists of a 600 gallons per minute (gpm) pumping assembly, hose assemblies, 6 inch butterfly valves, check valve, and coupling clamps. One of three different 600 GPM pumping assemblies may be supplied with the TWDS, reference paragraph 1.16. Refer to applicable technical manual for a description of 600 GPM pumping assembly characteristics. The 10-mile hoseline segment is constructed of 6 inch by 500 foot hose assemblies. At intervals of every 1,000 feet a swivel joint is installed to prevent hoseline damage or chinking during hoseline packing. A pressure-reducing valve assembly can be installed to reduce water pressure between two pumping stations. The storage assemblies store water, tapped from the main TWDS hose line, which can be dispensed at the distribution points or pumped further down line as required. The storage assembly is a 20,000 gallon pillow tank. For a description of the 20,000 gallon pillow tank, reference TM 5-5430-226-12. Each distribution point consists of a 125 GPM pumping assembly, a hypochlorination unit, a network of hoses and 2 inch gate valves, and three types of water dispensing equipment. Refer to applicable technical manual for a description of the characteristics of the 125 GPM pumping assembly. One of three different hypochlorination units may be supplied with the TWDS, reference paragraph 1.16. Refer to applicable technical manuals for a description of the characteristics of the model 1955-3 and model A-506131 hypochlorination units. The model 1955-1 hypochlorination unit can chlorinate water at a rate of up to 100 gpm. A 2 inch hose network and 2 inch gate valves direct water flow from the hypochlorination unit to the manual dispersing stations. Chlorinated water can be dispensed from a hand held nozzle, an elbow valve, or a 36 gallon water storage bag.

1.14.2 Capabilities and Features.

- Can transport water at 600 GPM across level terrain.
- Can transport 720,000 gallons of water within a 24 hour period.
- Can be deployed and operational within 48 hours.

1.15 LOCATION AND DESCRIPTION OF MAJOR COMPONENTS.

Figures 1-2 through 1-9 illustrate the major components of the TWDS. Tables 1-2 through 1-9 list the major components and provide a description of each major component.

1.15 LOCATION AND DESCRIPTION OF MAJOR COMPONENTS - CONTINUED.

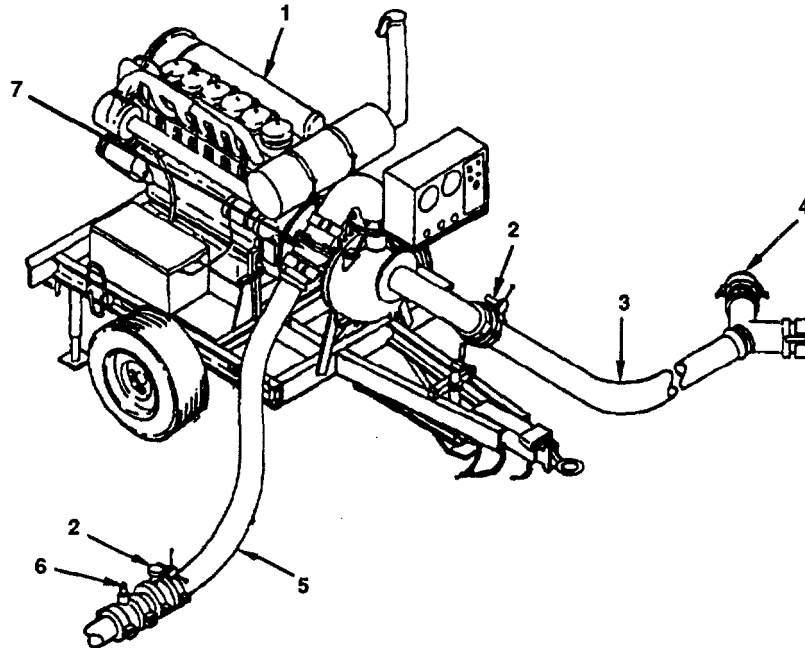


Figure 1-2. Location of Major Components for TWDS Lead Pumping Station.

Table 1-2. Description of Major Components for TWDS Lead Pumping Station.

Item No.	Item Name	Description and Purpose
1	LEAD PUMPING STATION	600 GPM pumping assembly. Pumps water from source and delivers it down line. One of three pumping assemblies may be supplied with the TWDS. Refer to applicable technical manual for detailed information concerning the pumping assemblies.
2	6 INCH BUTTERFLY VALVE	Used to control water flow into lead pumping assembly and from lead pumping assembly to hoseline.
3	HOSE ASSEMBLY	6 inch x 10 foot, rigid walled, wire reinforced hose assembly. Connects Y-Connection reducer to lead pumping station. Equipped with quick-disconnect fittings for rapid installation.
4	Y-CONNECTION REDUCER	Provides connection capability between the TWDS and water source.
5	HOSE ASSEMBLY	6 inch x 20 foot, collapsible hose assembly. Directs water from pumping assembly to hoseline.
6	PRESSURE RELIEF VALVE, (200 PSI)	Activates at water pressures over 200 psi to relieve excessive water pressure in hoseline assemblies.
7	CHECK VALVE	Retards water from flowing into pumping assembly through discharge elbow.

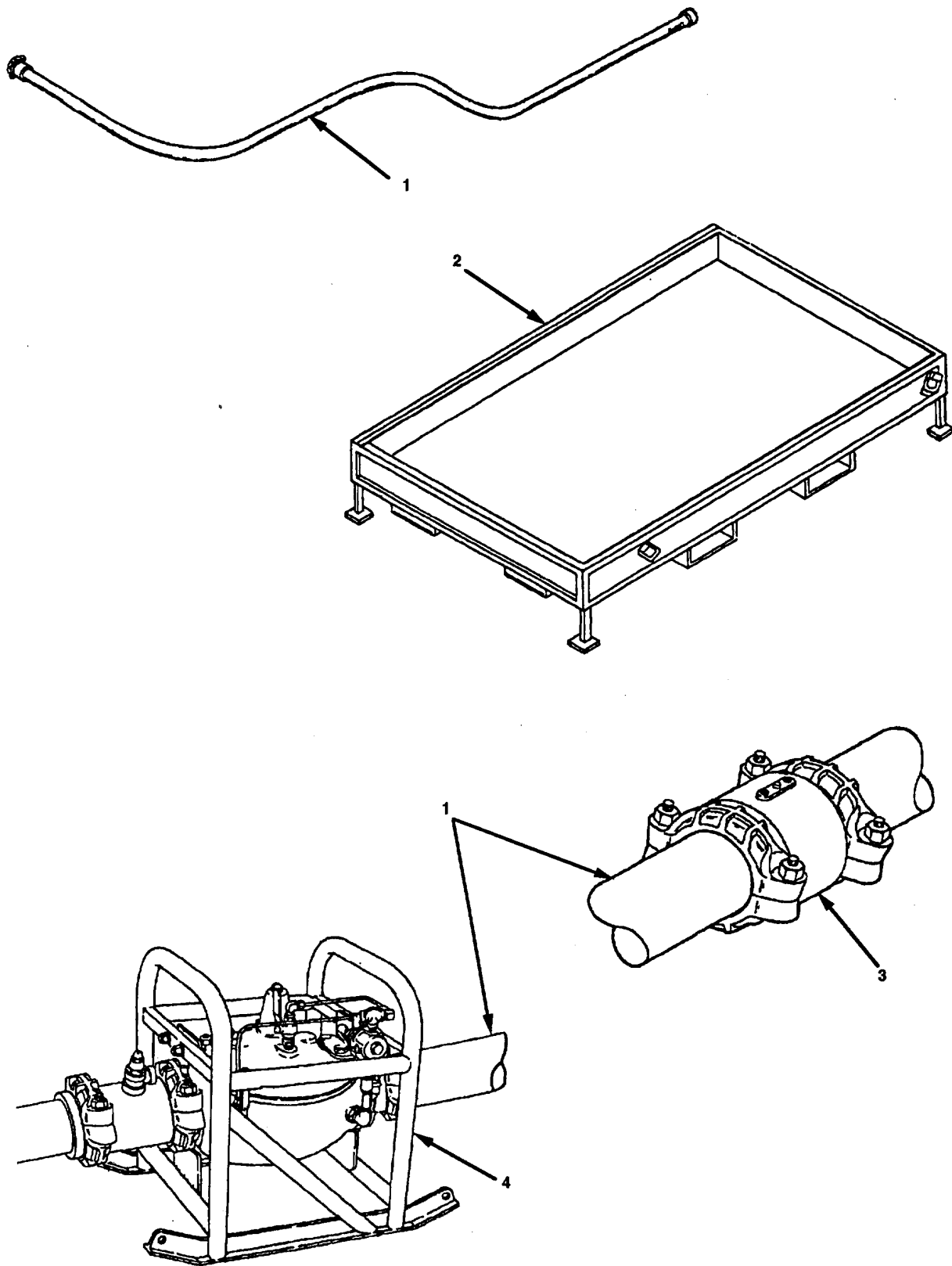


Figure 1-3. Location of Major Components for TWDS 10-Mile Hoseline Segment.

1.15 LOCATION AND DESCRIPTION OF MAJOR COMPONENTS - CONTINUED.

Table 1-3. Description of Major Components for TWDS 10-Mile Hoseline Segment.

Item No.	Item Name	Description and Purpose
1	6 INCH X 500 FOOT COLLAPSIBLE HOSE ASSEMBLY	Lightweight, collapsible, rubber hose used to transport water up to 10 miles and to interconnect TWDS components.
2	FLAKING BOX	Each new Flaking Box holds two 500 foot hose assemblies. Older models hold one 500 foot hose assembly. Allows hose assembly to be flaked from back of truck. Adapted for forklift and lifting sling.
3	SWIVEL JOINT	Placed between every 1,000 feet of hoseline to relieve twisting and kinking of hoseline.
4	PRESSURE REDUCING VALVE ASSEMBLY	Provides protection for hoseline and other TWDS components from excess pressure. Installed in hoseline where water pressure is expected to exceed 225 pounds per square inch (psi) and reduces pressure to 75 psi

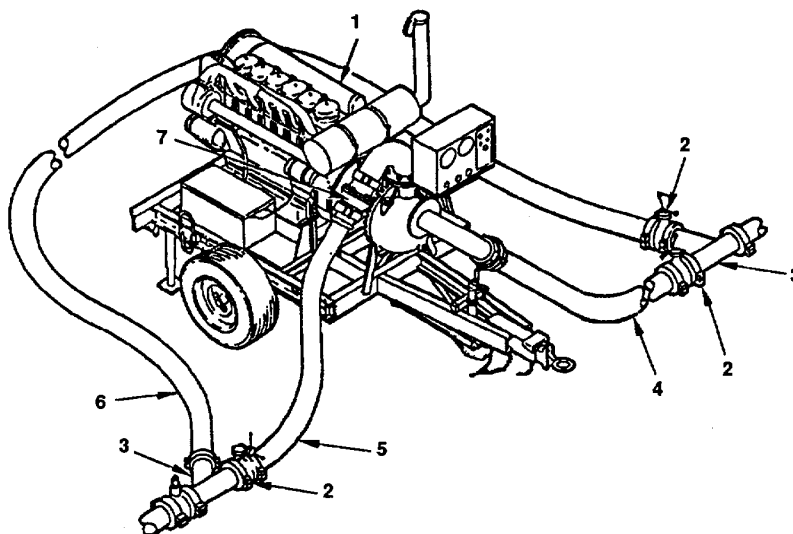


Figure 1-4. Location of Major Components for TWDS Boost Pumping Station.

Table 1-4. Description of Major Components for TWDS Boost Pumping Station.

Item No.	Item Name	Description and Purpose
1	BOOST PUMPING STATION	600 GPM pumping assembly. Pumps water from lead pumping station, or boost pumping station, and delivers it down line. One of three pumping assemblies may be supplied with the TWDS. Refer to applicable technical manual for detailed information concerning the pumping assemblies.

**Table 1-4. Description of Major Components for TWDS Boost Pumping Station.
(Continued)**

Item No.	Item Name	Description and Purpose
2	6 INCH BUTTERFLY VALVE	Three are used for the boost pumping station layout. Used to control water flow into boost pumping assembly, around boost pumping assembly and from boost pumping assembly to hoseline.
3	LATERAL PIPE FITTING	Two are used for the boost pumping station layout. Used to connect 6 inch x 500 foot collapsible hose assembly, 6 inch x 10 foot, 20 foot, and 75 foot hose assemblies.
4	HOSE ASSEMBLY	6 inch x 10 foot, collapsible hose assembly. Directs flow of water into suction port of boost pumping assembly.
5	HOSE ASSEMBLY	6 inch x 20 foot, collapsible hose assembly. Directs water flow from pumping assembly to hoseline.
6	BYPASS HOSE ASSEMBLY	6 inch x 75 foot, collapsible hose assembly. Directs flow of water around boost pumping station to hoseline.
7	CHECK VALVE	Retards water from flowing into pumping assembly through discharge elbow.

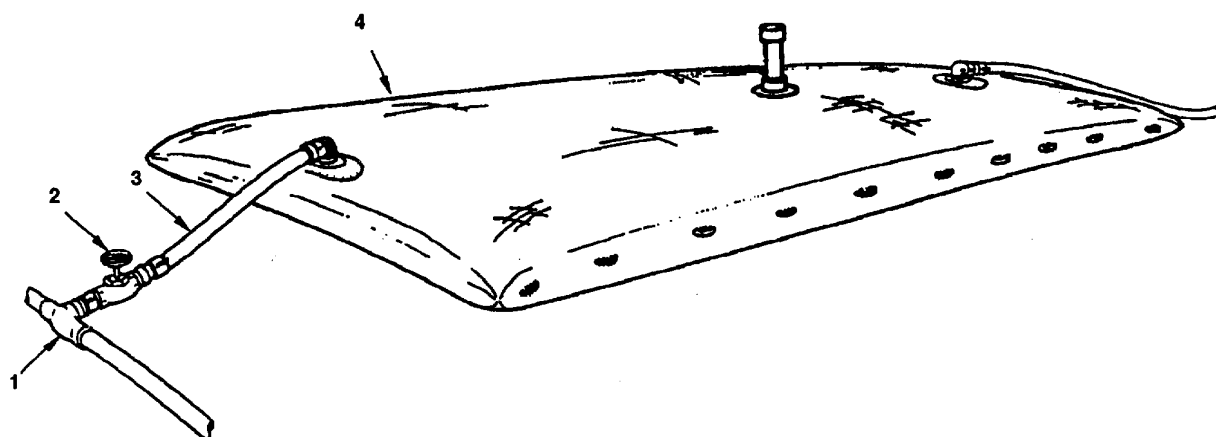


Figure 1-5. Location of Major Components for TWDS Storage Assembly.

Table 1-5. Description of Major Components for TWDS Storage Assembly.

Item No.	Item Name	Description and Purpose
1	6 INCH X 6 INCH X 4 INCH PIPE TEE	Used to connect storage assembly to hoseline.
2	4 INCH GATE VALVE ASSEMBLY	Used to control water flow into storage assembly.
3	4 INCH X 10 FOOT HOSE ASSEMBLY	Directs water flow from 4 inch gate valve to filler fitting on water storage tank.

1.15 LOCATION AND DESCRIPTION OF MAJOR COMPONENTS - CONTINUED.

Table 1-5. Description of Major Components for TWDS Storage Assembly. (Continued)

4	STORAGE TANK	20,000 gallon, collapsible, rubberized nylon, pillow tank. Used to supply TWDS distribution point or water storage. Refer to applicable technical manual for detailed information concerning the 20,000 gallon pillow tank.
---	--------------	---

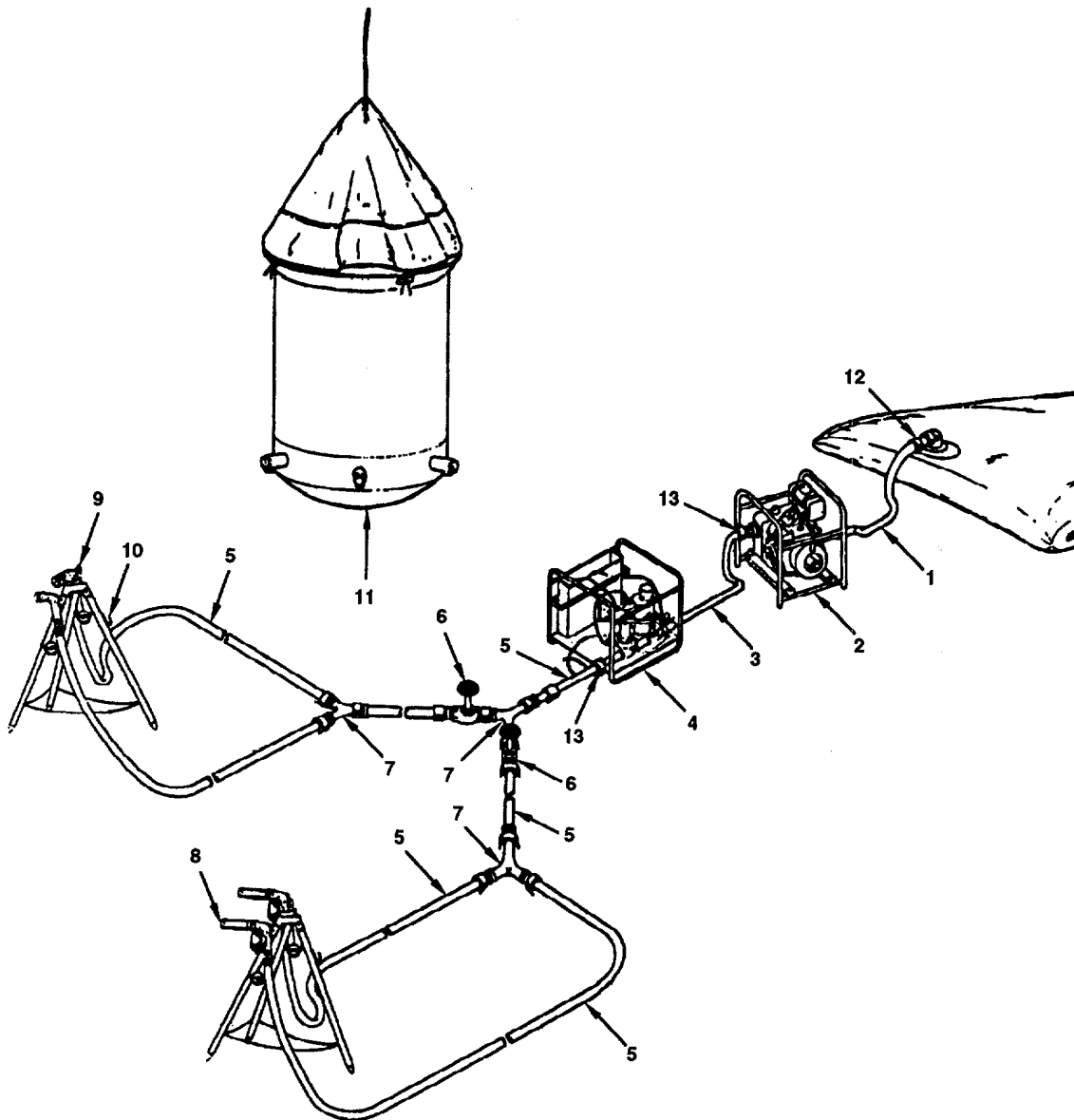


Figure 1-6. Location of Major Components for TWDS Distribution Point.

Table 1-6. Description of Major Components for TWDS Distribution Point.

Item No.	Item Name	Description and Purpose
1	HOSE ASSEMBLY	2 inch x 20 foot, rigid walled, hose assembly. Used to direct water flow from 20,000 gallon pillow tank to 125 GPM pumping assembly.
2	125 GPM PUMPING ASSEMBLY	Gas driven 125 GPM pumping assembly used to pump water from the 20,000 gallon pillow tank to the hypochlorination unit and water dispensing devices. Refer to applicable technical manual for detailed information concerning the 125 GPM pumping assembly.
3	HOSE ASSEMBLY	2 inch x 10 foot, collapsible hose assembly. Directs flow of water from 125 GPM pumping assembly to hypochlorination unit. Equipped with quick-disconnect fittings for rapid installation.
4	HYPOCHLORINATION UNIT	Used to chlorinate water to levels acceptable for consumption. One of three hypochlorination units may be supplied with the TWDS. Refer to applicable technical manuals for detailed information concerning models A-506131 and 1955-3. Detailed information concerning model 1955-1 is contained within this manual.
5	HOSE ASSEMBLY	Seven hose assemblies are used with each distribution point. 2 inch x 20 foot, collapsible hose assembly. Directs flow of water from 2 inch gate valve to nozzle and elbow valve.
6	2 INCH GATE VALVE ASSEMBLY	Two are used with each distribution point. Used to control water flow from hypochlorination unit to water dispensing points.
7	QUICK DISCONNECT WYE CONNECTION	Three are used with each distribution point. Used to direct water flow to distribution equipment.
8	NOZZLE	Two are used with each distribution point. Used to dispense water in small volumes with a pistol like action.
9	ELBOW VALVE	Two are used with each distribution point. Used to dispense water in large volumes, with the user controlling water flow volume.
10	NOZZLE ASSEMBLY STAND	Two are used with each distribution point. Collapsible tripod. Used to support nozzle and elbow valve when not in use.
11	DRINKING WATER STORAGE BAG	36 gallon capacity, cotton duck water storage bag. Faucets at bottom of bag used to distribute water to personnel.
12	REDUCER	Used to reduce water volume from the filler/discharge elbow to the rigid walled hose assembly.
13	ADAPTER	Two are used with each distribution point. Connects threaded ends of hypochlorination unit and 125 GPM pump to rigid walled hose assembly.

1.15 LOCATION AND DESCRIPTION OF MAJOR COMPONENTS - CONTINUED.

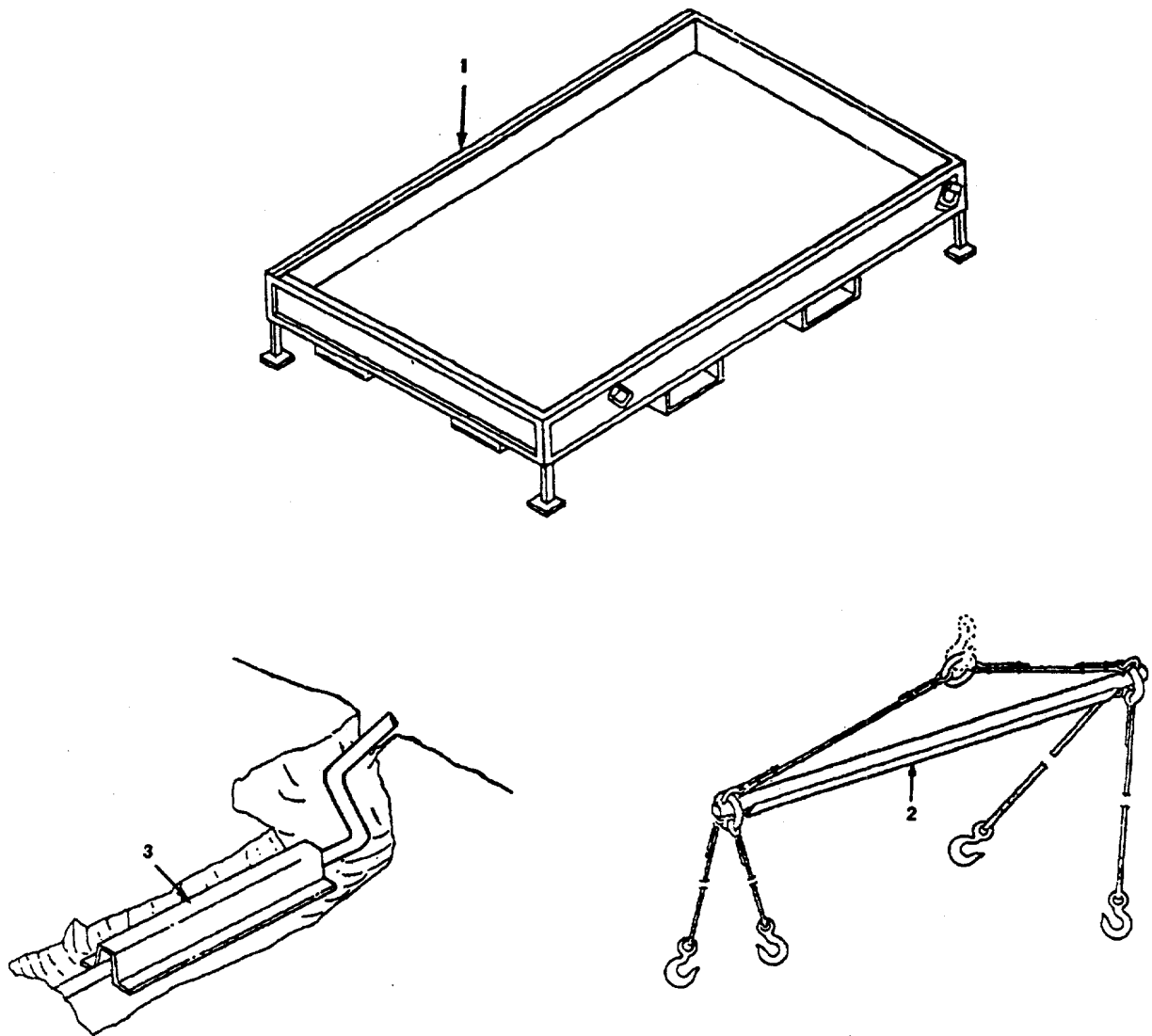


Figure 1-7. Major Support Components for TWDS.

Table 1-7. Description of Major Support Components for TPWDS.

Item No.	Item Name	Description and Purpose
1	FLAKING BOX	Newer model flaking box holds two 500 foot hose assemblies. Older model flaking box holds one 500 foot hose assembly. Allows hose to be flaked from back of vehicle. During flaking of hoses the flaking boxes are stacked four high. Adapted for either forklift or sling lift.
2	LIFTING SLING	Used for lifting flaking boxes when a forklift is not available.
3	ROAD CROSSING GUARD	Used to protect hoseline buried beneath road from damage.

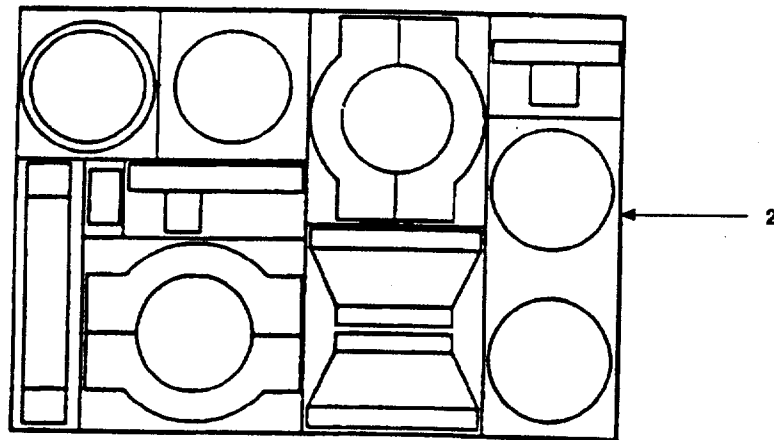
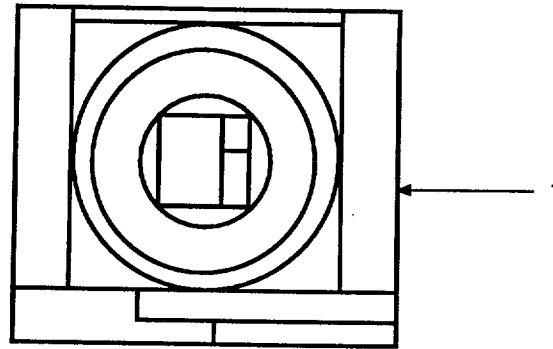


Figure 1-8. Suspension Kit and Displacement and Evacuation Kit.

Table 1-8. Description of Suspension Kit and Displacement and Evacuation Kit.

Item No.	Item Name	Description and Purpose
1	SUSPENSION KIT	Used to construct suspensions across streams, ponds, or gullies. (Reference item 112, Appendix C)
2	DISPLACEMENT AND EVACUATION KIT	Used to remove water and air from 500 foot hose sections prior to packing. (Reference item 98, Appendix C)

1.15 LOCATION AND DESCRIPTION OF MAJOR COMPONENTS - CONTINUED.

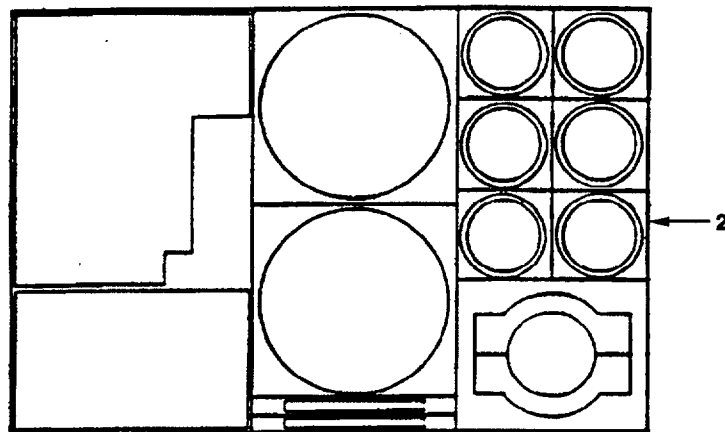
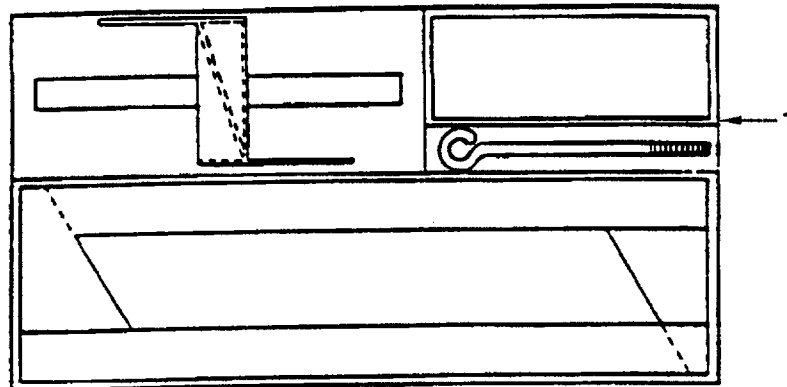


Figure 1-9. Packing Kit and Repair Kit.

Table 1-9. Description of Packing Kit and Repair Kit.

Item No.	Item Name	Description and Purpose
1	PACKING KIT	Used to pack 500 foot hose sections into flaking box. (Reference item 89, of Appendix C)
2	REPAIR KIT	Used to repair 6 inch hose sections. (Reference item 124, Appendix C)

1.16 DIFFERENCES BETWEEN MODELS.

Differences between the TWDS models are identified in Table 1-10. An "X" under the applicable model number column heading indicates that the item is a component of that model.

Table 1-10. Differences Between Models.

Equipment Characteristics	Model 06749- 0183-81	Model 110-00- 0000	Model 919	Model 10
Trailer Mounted Pumping Assembly: Model 609-A	X	X		
Trailer Mounted Pumping Assembly: Model 609-C				X
Trailer Mounted Pumping Assembly: Model US636HCCD-1			X	
Hypochlorination Unit: Model 1955-1	X		X	
Hypochlorination Unit: Model 1955-3	X		X	X
Hypochlorination Unit: Model A-506131		X		

1.17 EQUIPMENT DATA.

1.17.1 Trailer Mounted Pumping Assemblies. Refer to applicable technical manual for installation and operation procedures for Trailer Mounted Pumping Assemblies Models: 609-A, 609-C, and US636HCCD-1. The performance and equipment data for the Trailer Mounted Pumping Assemblies are provided below.

1.17.1.1 Pumping Assembly, Model 609-A.

Weight (dry)	3,052 lb (1,384 kg)
Length	139 in. (353 cm)
Width	70 in. (178 cm)
Height	90 in. (229 cm)
<u>Pump</u>	
Type	Self-priming, centrifugal, direct-coupled to diesel engine
Output volume	600 gpm at 350 ft tdh
Designed working pressure	150 + 5 psi (1,034 + 34 kPa)
Designed suction pressure	-30 to 200 psi (138 to 1,034 kPa)
Suction and discharge size	6 in. (15 cm)
<u>Engine</u>	
Type	4-stroke, 6-cylinder, liquid-cooled, turbocharged diesel
Bore	4 in. (10 cm)
Stroke	4.5 in. (11 cm)
Piston displacement	339 cu in. (5,555 cu cm)
Compression ratio	16:1
Weight	1,050 lb (476 kg)
Power output	120 hp at 2,400 rpm
Speed (maximum)	2,500 rpm
Idle speed (minimum)	1,000 rpm
Fuel	diesel
Lubrication	forced lubrication
Valve clearance (cold)	0.015 in. (0.381 mm)
Crankcase capacity	6 qt (5.7 L)
Fuel tank capacity	12 gal (45.42 L)
Radiator capacity	7 gal (26.50 L)
Weight (dry)	4,600 lb (2,088 kg)
Length	158.19 in. (402 cm)
Width	84 in. (214 cm)
Height	72 in. (183 cm)

1.17.1.2 Pumping Assembly, Model 609-C.Pump

Type	Self-priming, centrifugal,
direct-coupled to diesel engine	
Output volume	600 gpm at 350 ft tdh
Designed working pressure	150 ± 5 psi (1,034 ± 34 kPa)
Designed suction pressure	-30 to 200 psi (138 to 1,034 kPa)
Suction and discharge size	6 in. (15 cm)

Engine

Type	4-stroke, 6-cylinder, air-cooled, altitude compensated, turbocharged diesel
Bore	100 mm (3.937 in.)
Stroke	120 mm (4.724 in.)
Piston displacement	5,655 cu cm (345 cu in.)
Compression ratio	17:1
Weight	440 kg (970 lb)
Power output (maximum)	109 hp (80 kW) at 2,400 rpm
Speed (maximum)	3,000 rpm
Idle speed (minimum)	650 rpm
Fuel	diesel or JP-4
Lubrication	forced lubrication
Valve clearance (cold)	0.15 mm (0.006 in.)
Crankcase capacity	11.82 L (12.5 qt)
Fuel tank capacity	113.55 L (30 gal)

1.17.1.3 Pumping Assembly, Model US636HCCD-1.

Weight (dry)	2,400 lb (1,090 kg)
Length	135 in. (343 cm)
Width	70 in. (178 cm)
Height	69 in. (174 cm)

Pump

Type	Self-priming, centrifugal, direct-coupled to diesel engine
Output volume	600 gpm at 350 ft tdh
Designed working pressure	150 ± 5 psi (1,034 ± 34 kPa)
Designed suction pressure	-30 to 200 psi (138 to 1,034 kPa)
Suction and discharge size	6 in. (15 cm)

Engine

Type	4-stroke, 6-cylinder, air-cooled, turbocharged diesel
Bore	102 mm (4.015 in.)
Stroke	125 mm (4.922 in.)
Piston displacement (entire) (inch)	6,128 cu cm (374 cu in.)
Compression ratio	15.5:1
Weight	515 kg (1,133 lb)
Power output (maximum)	160 hp (118 kW) at 2,500-2,800 rpm
Speed (maximum)	2,500 rpm
Idle speed (minimum)	650 rpm
Fuel	diesel or JP-4
Lubrication	forced lubrication
Valve clearance (cold)	0.15 mm (0.006 in.)
Crankcase capacity	15.136 L (16 qt)
Fuel tank capacity	45.42 L (12 gal)

1.17.2 20,000 Gallon Pillow Tank. Refer to applicable technical manual for equipment data on the 20,000 Gallon Pillow Tank.

1.17.3 125 GPM Pumping Assembly. Refer to applicable technical manual for equipment and performance data on the 125 GPM pumping assembly.

1.17.4 Hypochlorination Units. Refer to applicable technical manual for equipment and performance data on model 1955-3. Refer to applicable technical manual for equipment and performance data on model A-506131. The equipment and performance data for model 1955-1 is detailed below.

Weight	166 lb (75 kg)
Length	26 inches (66 cm)
Width	18 inches (45 cm)
Height	28 inches (71 cm)
Flow	100 gpm maximum
2 gpm minimum	
Ambient Temperature Range	350 to 1300 F (1.70 to 54.4° C)
Range	10:1
Hypochlorinator Feed Rate	55 gpm
Reservoir Container Capacity	5 gal (19 L)
Inlet and Outlet Pipe Size	2 inch female pipe thread

1.18 EQUIPMENT CONFIGURATION.

The TWDS can be deployed in multiple configurations. The configurations are dependent on the application of the TWDS and the terrain over which the system is deployed. When the TWDS is deployed over smooth terrain five pumping stations are required. When the TWDS is deployed over rough terrain six pumping stations are required. During rough terrain deployment if there is a decrease in elevation of 75 feet or greater between two pumping stations a pressure-reducing valve assembly can be installed in the main hose line to reduce water pressure and protect down line equipment from damage. When the TWDS is deployed for transporting water from a source to a large storage or distribution unit, only the pumping stations and 10- mile hose line segment are required. For water distribution to personnel or storage three configurations can be employed. First, one storage assembly and distribution point can be installed in the TWDS. Second, two storage assemblies and distribution points can be installed in the TWDS. Third, if only transporting and water storage capabilities are required, the TWDS can be deployed without the distribution points.

SECTION III. PRINCIPLES OF OPERATION

1.19 FUNCTIONAL DESCRIPTION.

The TWDS is used to transport potable water across level terrain for distances up to 10 miles. Five or six pumping assemblies are used to transport water from a source, desalination units, wells, or large storage and distribution units, to two 20,000 gallon storage assemblies, additional TWDS units, or larger storage and distribution units. The water stored in the two 20,000 gallon pillow tanks can be supplied to large storage or distribution units or can be chlorinated and dispensed to personnel through two distribution points. A functional description of each functional unit comprising the TWDS is provided in the following paragraphs. 1.19.1 Pumping Stations. There are two different types of pumping stations required for the TWDS. Each pumping station consists of a trailer mounted pumping assembly, a check valve, three 6 inch butterfly valves, various 6 inch hose assemblies as detailed below. The pump assembly is powered by a 6 cylinder diesel engine. Pump operation is controlled through a control panel mounted on the pump assembly. Refer to applicable technical manual for a complete functional description of the 600 GPM pumping assembly. A functional description of each type of pumping station is provided below.

1.19.1.1 Lead Pumping Station. Draws water from desalination units, wells, or large storage and distribution units. A Y-Connection Reducer and 6 inch by 10 foot rigid walled hose assembly connect the lead pumping station to the water source. The lead pumping station pumps water down line to first boost pump station. A hose assembly connects the lead pumping station to the 10-mile hose segment. Manual operation of 6 inch butterfly valves on the hose assemblies controls water flow into and away from lead pump. A check valve is installed on the discharge elbow of the pumping assembly to restrict reverse water flow. Refer to applicable technical manual for a functional description on the operation of the pumping assembly and location of discharge elbow.

1.19.1.2 Boost Pumping Stations. Receives water from up line hose segments. Pumps water down line to next boost pumping station or to storage assembly. Manual operation of 6 inch butterfly valves on the hose assemblies controls water flow into, away from, or around each boost pumping assembly. A check valve is installed on the discharge elbow of the pumping assembly to restrict reverse water flow into the pumping assembly's discharge elbow. A pressure relief valve is installed between the boost pumping station and the down line hose segment to reduce water pressure when water pressure exceeds 200 pounds per square inch (psi) when leaving the boost pumping station. Refer to applicable technical manual for a functional description on the operation of the pumping assembly and location of discharge elbow.

1.19.2 Storage Assembly. The storage assembly is connected to the main TWDS hoseline by a 6 inch x 6 inch x 4 inch tee pipe. A series of couplers, 4 inch gate valve, and a 4 inch x 10 foot hose assembly connect the 20,000 gallon pillow tank to the tee pipe. Each storage assembly can collect up to 20,000 gallons of water tapped from the main TWDS hoseline. The storage assembly water fill rate is controlled by manual operation of the 4 inch gate valve. Water can be stored in the storage assembly for later use or can be supplied to distribution points for dispensing to personnel. Refer to applicable technical manual for a functional description of the 20,000 gallon storage assembly.

1.19.3 10-Mile Hoseline Segment. The 10-mile hoseline segment consists of 6 inch x 500 foot collapsible hose assemblies. The 10-mile hoseline segment transfers water to the major components of the TWDS. This segment is used to connect pumping stations and storage assemblies. A swivel joint is installed every 1,000 feet to prevent damage and kinking of the hoseline segment during hoseline packing or pressure surges during operation of the TWDS. The 500 foot hose sections are stored in flaking boxes. The flaking boxes can be stacked four high and can be loaded or unloaded by either a forklift or lifting sling and crane. A skid mounted pressure-reducing valve assembly is installed where hoseline pressure is expected to exceed 225 psi, usually if there is an elevation drop of 75 feet or greater between pumping stations. A pressure relief valve is installed just before the pressure reducing valve assembly to reduce water pressure when water pressure exceeds 200 psi. Suspension devices are used to route the 10-mile hoseline segment over obstacles in terrain. A road crossing guard is used to protect hose segments from damage when the hose segments are buried under a road bed. An end cap can be installed if dead-end service is required or the hoseline can be coupled with an additional TWDS or distribution and storage unit.

1.19.4 Distribution Points. Each distribution point consists of a 125 GPM pumping assembly, a hypochlorination unit, a network of hoses, two stands for nozzles and elbow valves, and four water storage bags. The 125 GPM pumping assembly draws water from the water storage assembly and delivers it to the hypochlorination unit. The hypochlorination unit injects chlorine into the water supply to purify it for personnel consumption. The water is then routed through the hose network to manual dispersing stations for distribution to personnel. A functional description of each functional unit comprising the distribution point is provided in the following paragraphs.

1.19.4.1 125 GPM Pumping Assembly. The 125 GPM pumping assembly is used to extract water from the 20,000 gallon storage assembly and deliver it to the hypochlorination unit. The 125 GPM pumping assembly is a skid mounted, gasoline engine driven pump which is manually controlled. Refer to applicable technical manual for a functional description of the 125 GPM pumping assembly.

1.19.4.2 Hypochlorination Unit. The hypochlorination unit is used to inject chlorine into the water supply, at a steady rate, to purify water for personnel consumption. The hypochlorination unit is skid mounted and powered by an impulse diaphragm motor which operates on water pressure. Chlorine injection rate is controlled by adjustment of pump stroke. Water flow rate through the hypochlorination unit is controlled by adjusting in-line valves. After controls are initially set no further adjustment is usually required. A proper chlorine dosage will be injected into the water regardless of water flow rate through the hypochlorination unit. The operator is required to periodically fill the five gallon chlorine solution reservoir. Water is periodically tested at the manual disbursing stations for chlorine content using a color comparator. Refer to applicable technical manual for a functional description of hypochlorination units, model 1955-3 and model A-506131.

1.19.4.3 Hose Network and Manual Dispersing Stations. The hose network is used to transport water from the 20,000 gallon water storage assembly to the 125 GPM pumping assembly, hypochlorination unit, and manual dispersing stations. A 2 inch x 20 foot rigid walled, hose assembly directs water flow from the 20,000 gallon pillow tank to the 125 GPM pumping assembly. A 2 inch x 10 foot collapsible hose assembly directs water flow from the 125 GPM pumping assembly to the hypochlorination unit. Water flow from the hypochlorination unit to the manual dispersing stations is directed by a series of 2 inch x 20 foot hose assemblies. Water flow to each of the manual disbursing stations is controlled by a 2 inch gate valve. The hose network ends at four manual dispersing stations. Two manual dispersing stations are equipped with nozzles and two with elbow valves. The nozzles and elbow valves are stored on a nozzle stand assembly when not in use. All hoses in the hose network are equipped with quick-disconnect fittings to allow for rapid installation and disassembly of the distribution point. Up to four 36 gallon water storage bags, suspended on tripods and fitted with faucets, are used to disperse water to personnel for canteens and other small containers. Operator is required to refill water storage bags periodically.

1.19.5 TWDS Support and Supply Kits. The TWDS is supplied with metal chests containing materials required to construct suspension devices, repair 6 inch hoseline segments, and prepare 6 inch by 500 foot hoseline segments for storage. The kits are detailed below. A functional description of each support and supply kit is provided in the following paragraphs.

1.19.5.1 Suspension Kit. The suspension kit is comprised of five metal chests containing kits of materials for constructing suspensions across streams, ponds, or gullies. Each kit contains enough rope, cable, saddles, sheeve blocks, shackles, turnbuckles, and pickets to construct one suspension spanning 200 feet or two shorter spans. Materials suitable for constructing tripods are not included in the kit and must be procured or fabricated locally.

1.19.5.2 Displacement and Evacuation Kit. The displacement and evacuation kit is used to remove water and air from the hoseline prior to packing. An air compressor is required to operate the kit. Using compressed air as a propellant a polyurethane ball, which fits snugly within the hose, is forced through the hose. As the ball passes through the hose it displaces the water. The ball is captured by a receiver after exiting the hose. The hose end is then plugged and a vacuum is applied until the air within the hose is evacuated and the hose collapses. As the hose collapses, end caps are installed to prevent the hose from expanding before it is packed.

1.19.5.3 Hoseline Repair Kit. This kit includes enough adapters and couplings to make up to three hose repairs on the 6 inch hose assemblies. Two hose clamps are provided to isolate hose sections while repairs are being performed.

CHAPTER 2
OPERATING INSTRUCTIONS

Subject Index	Page
SECTION I. DESCRIPTION AND USE OF OPERATOR'S CONTROLS AND INDICATORS.....	2-2
2.1 Operator's Controls and Indicators.....	2-2
SECTION II. OPERATOR PREVENTIVE MAINTENANCE CHECKS AND SERVICES (PMCS)	2-8
2.2 General.....	2-8
SECTION III. OPERATION UNDER USUAL CONDITIONS	2-16
2.3 Assembly and Preparation for Use.....	2-30
2.4 Initial Adjustments, Checks, and Self Test.....	2-75
2.5 Operating Procedures.....	2-75
2.6 Decals and Instruction Plates.....	2-88
2.7 Operation of Auxiliary Equipment	2-88
2.8 Preparation for Movement	2-89
2.9 Operation in Unusual Weather.....	2-114
2.10 Nuclear, Biological, and Chemical (NBC).....	2-115
2.11 Fording	2-115
2.12 Emergency Procedures	2-115

SECTION I. DESCRIPTION AND USE OF OPERATOR'S CONTROLS AND INDICATORS

2.1 OPERATOR'S CONTROLS AND INDICATORS.

2.1.1 Lead Pumping Station. See figure 2-1 and table 2-1.

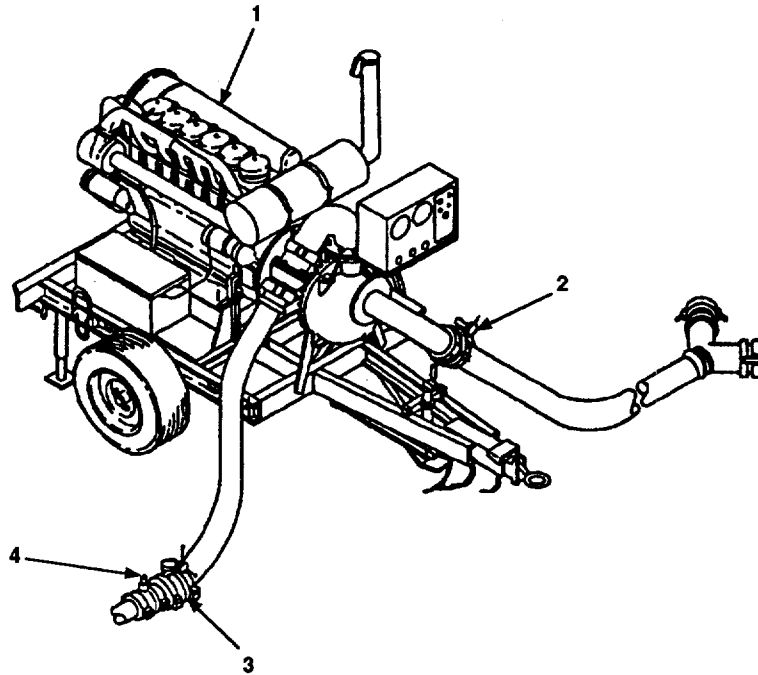


Figure 2-1. Operator's Controls and Indicators for TWDS Lead Pumping Station.

Table 2-1. Description of Operator's Controls and Indicators for TADS Lead Pumping Station.

Item No.	Item Name	Description and Purpose
1	LEAD PUMPING STATION	600 gpm pumping assembly. Reference applicable technical manual for a description of the operator's controls and indicators for the 600 gpm pumping assemblies.
2	6 INCH BUTTERFLY VALVE (SUCTION)	Used to control water flow into lead pumping assembly. Open to route water flow from water source through pump. Close to shut off pump from water source.
3	6 INCH BUTTERFLY VALVE (DISCHARGE)	Used to control water flow down line from lead pumping assembly. Open to route water flow down line. Close to shut off down line water flow.
4	PRESSURE RELIEF VALVE	Releases pressure in 10-mile hoseline segment when pressure exceeds 200 pounds per square inch (psi).

2.1.2 **TWDS 10-Mile Hoseline Segment.** See figure 2-2 and table 2-2.

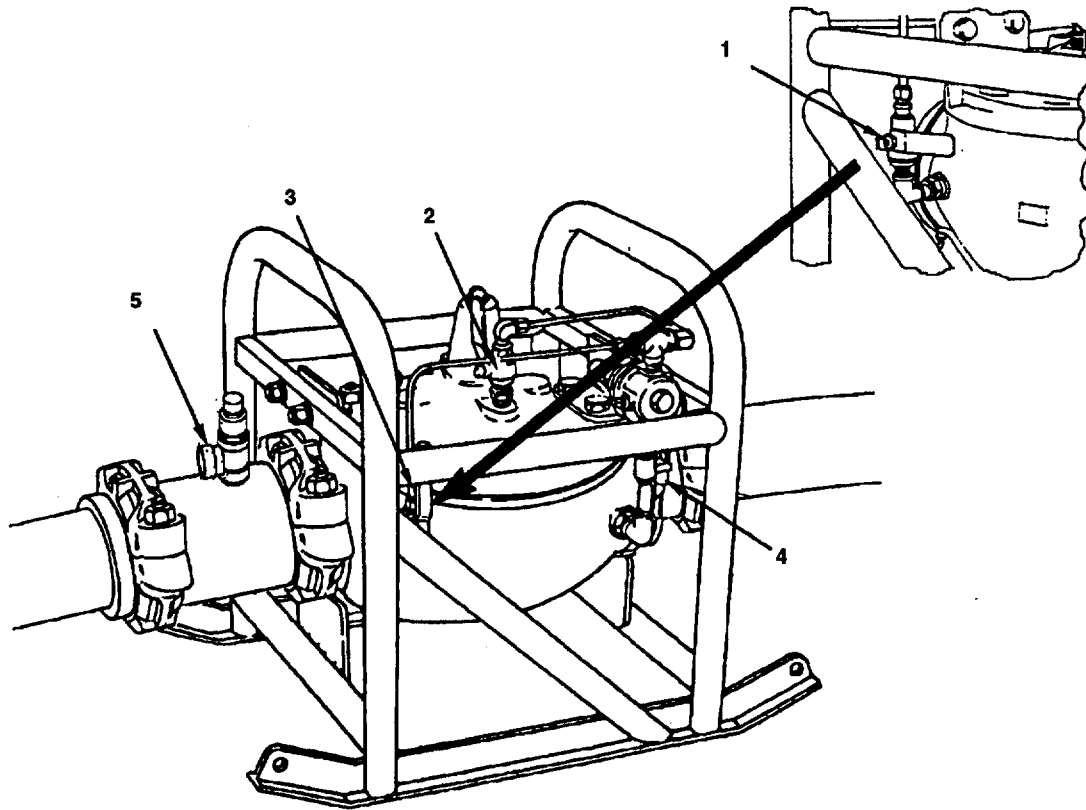


Figure 2-2. Operator's Controls and Indicators for TWDS 10-Mile Hoseline Segment.

Table 2-2. Description of Operator's Controls and Indicators for TWDS 10-Mile Hoseline Segment.

Item No.	Item Name	Description and Purpose
1	ISOLATION COCK VALVE	Used to manually turn pressure reducing valve assembly on and off. Three are present on the pressure reducing valve assembly.
2	TOP ISOLATION COCK VALVE	Applies pressure to diaphragm.
3	OUTLET PRESSURE VALVE	Releases water from pressure regulator into pressure reducing valve.
4	INLET PRESSURE VALVE	Supplies water from 10-mile hoseline segment to pressure regulator.
5	PRESSURE RELIEF VALVE	Releases pressure in 10-mile hoseline segment when pressure exceeds 200 pounds per square inch (psi).

2.1.3 **Boost Pumping Station.** See figure 2-3 and table 2-3.

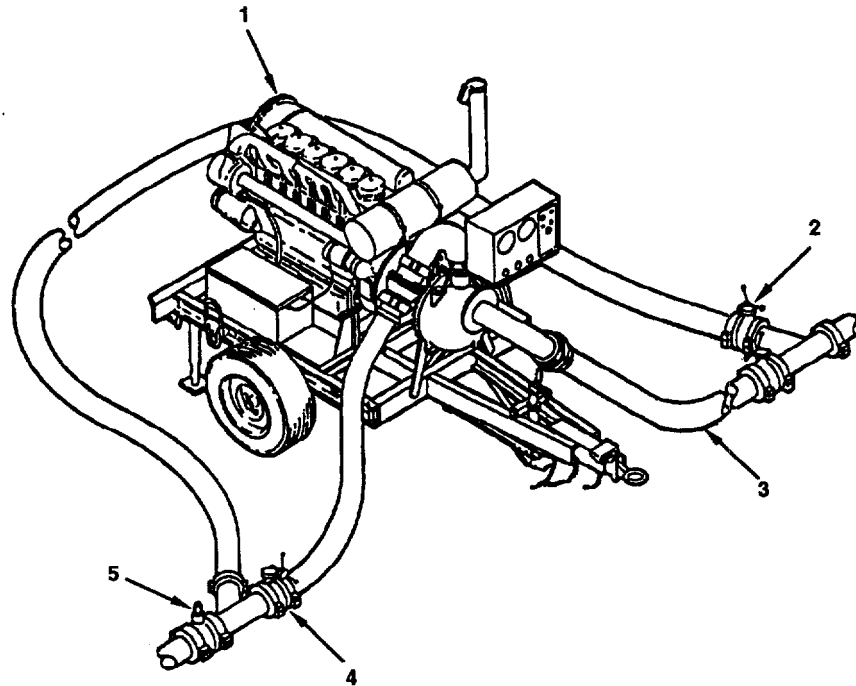


Figure 2-3. Operator's Controls and Indicators for TWDS Boost Pumping Station.

Table 2-3. Description of Operator's Controls and Indicators for TWDS Boost Pumping Station.

Item No.	Item Name	Description and Purpose
1	BOOST PUMPING STATION	600 gpm pumping assembly. Reference applicable technical manual for a description of the operator's controls and indicators for the 600 gpm pumping assemblies.
2	6 INCH BUTTERFLY VALVE (BYPASS)	Used to control flow through bypass hose assembly. Closed to shut off bypass hose assembly. Open to direct water through bypass hose assembly.
3	6 INCH BUTTERFLY VALVE (SUCTION)	Used to control water flow into lead pumping assembly. Open to route water flow from water source through pump. Close to shut off pump from water source.
4	6 INCH BUTTERFLY VALVE	Used to control water flow down line from lead (DISCHARGE) pumping assembly. Open to route water flow down line. Close to shut off down line water flow.
5	PRESSURE RELIEF VALVE	Releases pressure when boost pumping station discharge pressure exceeds 200 psi.

2.1.4 **TWDS Storage Assembly.** See figure 2-4 and table 2-4.

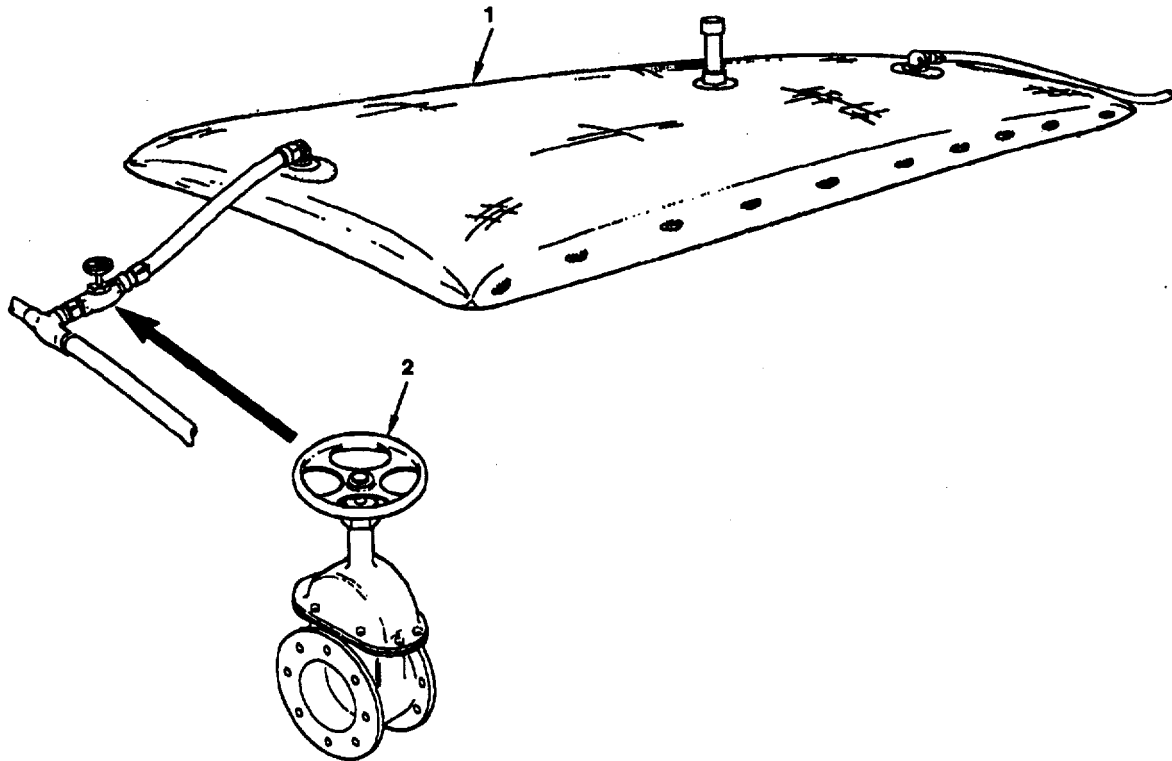


Figure 2-4. Operator's Controls and Indicators for TWDS Storage Assembly.

Table 2-4. Description of Operator's Controls and Indicators for TWDS Storage Assembly.

Item No	Item Name	Description and Purpose
1	STORAGE TANK	20,000 gallon, collapsible, rubberized nylon, pillow tank. Reference applicable technical manual for a description of the operator's controls and indicators for the 20,000 gallon pillow tank.
2	4 INCH GATE VALVE ASSEMBLY	Used to control water flow into storage assembly.

2.1.5 **TWDS Distribution Point.** See figure 2-5 and table 2-5.

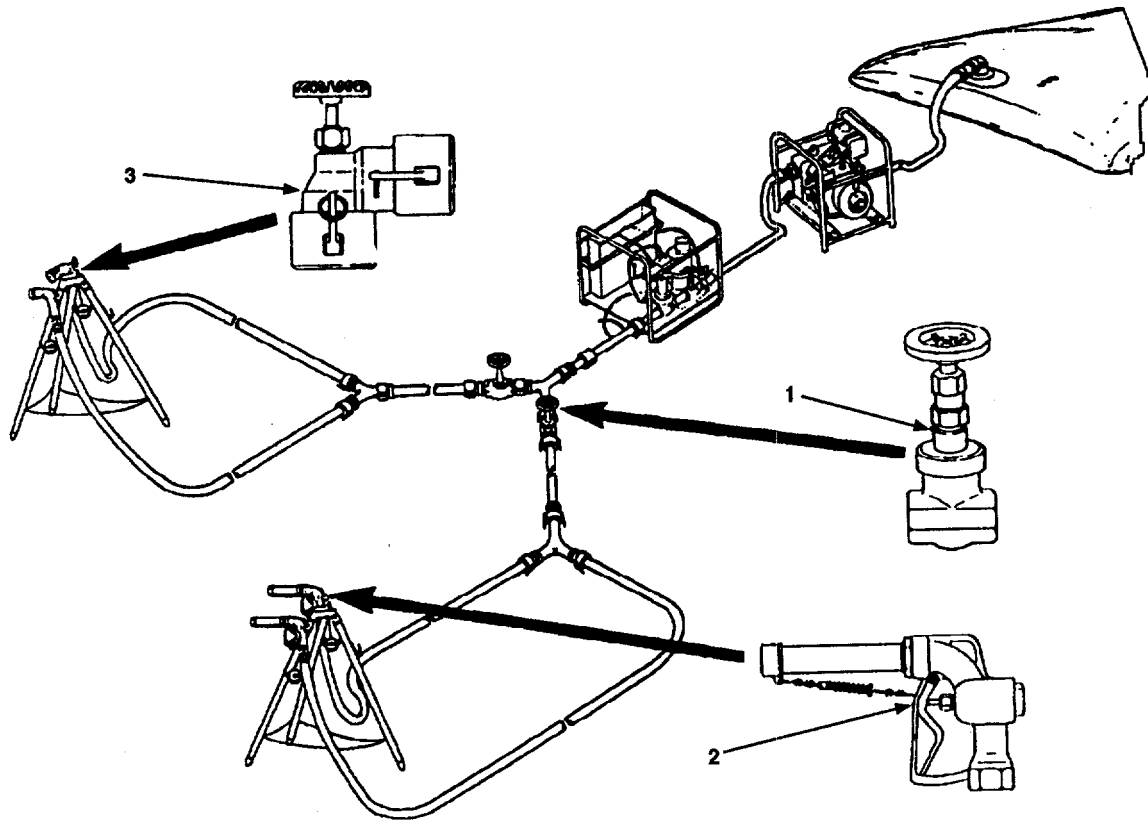


Figure 2-5. Operator's Controls and Indicators for TWDS Distribution Point.

Table 2-5. Description of Operator's Controls and Indicators for TWDS Distribution Point.

Item No	Item Name	Description and Purpose
1	2 INCH GATE VALVE ASSEMBLY	Used to control water flow to manual dispersing stations.
2	NOZZLE	Used to control flow of water at manual dispersing stations when attached to hose end.
3	ELBOW VALVE ASSEMBLY	Used to control flow of water at manual dispersing stations when attached to hose end.

2.1.5.1 **125 GPM Pumping Assembly.** Reference applicable technical manual for a description of the operator's controls and indicators for the 125 GPM pumping assembly.

2.1.5.2 **Hypochlorination Unit.** See figure 2-6 and table 2-6 for a description of the operator's controls and indicators for the hypochlorination unit, model 1955-1. Reference applicable technical manuals for a description of the operator's controls and indicators for the hypochlorination units, model 1955-3 and model A-506131.

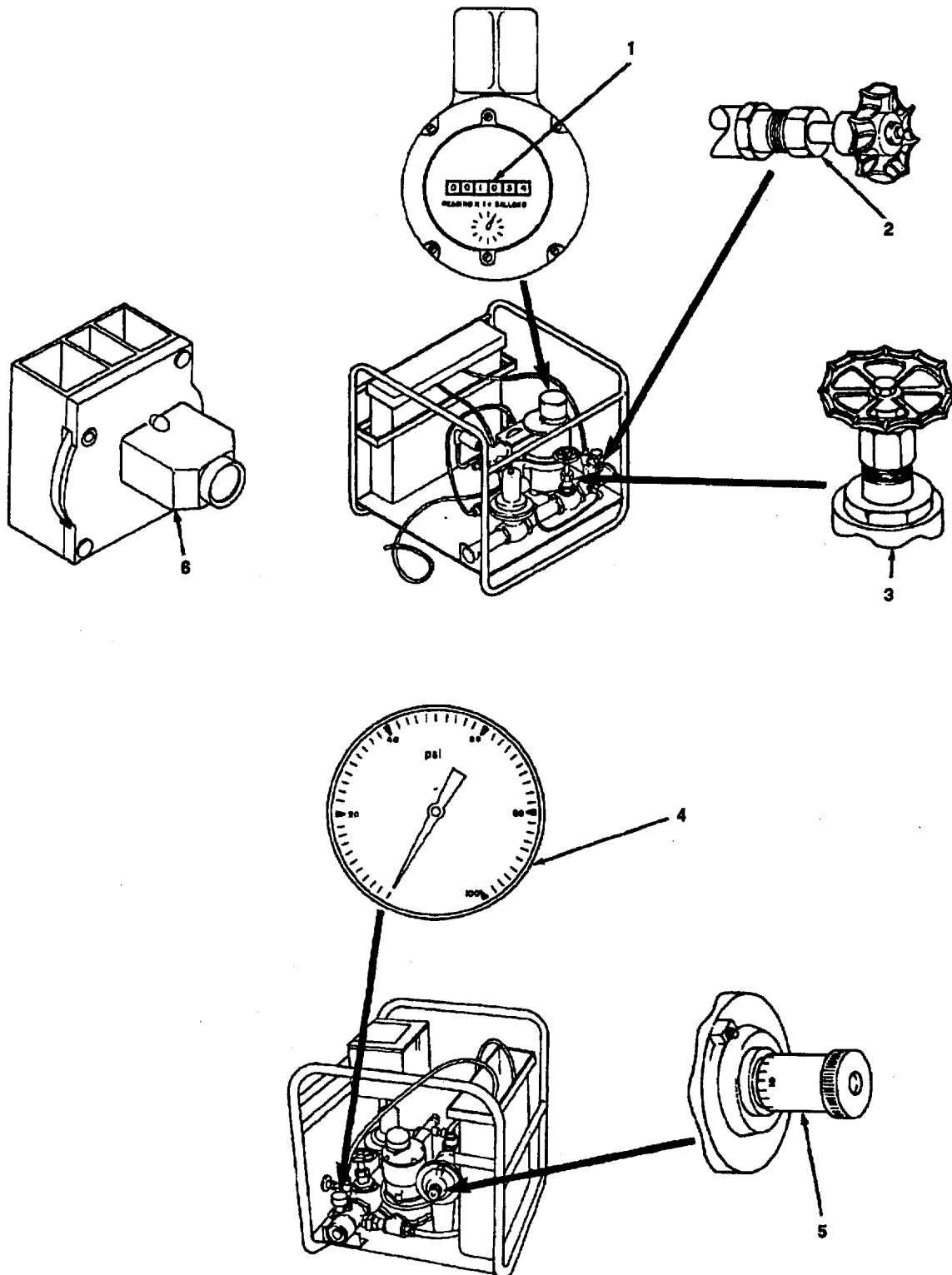


Figure 2-6. Operator's Controls and Indicators for Hypochlorination Unit, Model 1955-1.

Table 2-6. Description of Operator's Controls and Indicators for Hypochlorination Unit, Model 1955-1.

Item No.	Item Name	Description and Purpose
1	WATER METER REGISTER	Used to display amount of water flowing through hypochlorinator unit up to 999,999 gallons.
2	WATER RESERVOIR FILL (GLOBE) VALVE	Used to fill plastic reservoir with water. Open to fill reservoir.
3	RANGE ADJUSTING (GLOBE) VALVE	Used to control water flow through hypochlorination unit. Open to route water through hypochlorination unit. Close to eliminate water flow through hypochlorination unit.
4	WATER PRESSURE GAUGE	Displays operating pressure of hypochlorination unit. Range is 0 to 100 psi.
5	STROKE ADJUST KNOB	Used to set stroke length of impulse diaphragm. Stroke length determines the quantity of chlorine solution pumped into water per stroke. Micrometer barrel is marked 0 to 10. Stroke adjustment thimble is marked 0 to 20.
6	COLOR COMPARATOR	Used to determine amount of chlorine solution present in water.

SECTION II. OPERATOR PREVENTIVE MAINTENANCE CHECKS AND SERVICES (PMCS)

2.2 GENERAL.

Figure 2-7 (PMCS) routing diagram and table 2-7 (PMCS table) have been provided so you can keep your TWDS equipment, including hypochlorination unit 1955-1, in good operating condition and ready for its primary mission. Refer to the applicable technical manuals for specific component PMCS:

- a. 125 GPM Pumping Assembly
- b. 20,000 Gallon Pillow Tank
- c. Hypochlorination Unit, Model A-506131
- d. Hypochlorination Unit, Model 1955-3
- e. 600 GPM Pumping Assemblies

2.2.1 Warnings and Cautions. Always observe the WARNINGS and CAUTIONS appearing in your PMCS table. WARNINGS and CAUTIONS appear before applicable procedures. You must observe these WARNINGS and CAUTIONS to prevent serious injury to yourself and others or prevent your equipment from being damaged.

2.2.2 Explanation of Table Entries.

2.2.2.1 Item No. Column. Numbers in this column are for reference. When completing DA Form 2404 (Equipment Inspection and Maintenance Worksheet), include the item number for the check/service indicating a fault. Item numbers also appear in the order that you must do checks and services for the intervals listed.

2.2.2.2 Interval Column. This column tells you when you must do the procedure in the procedure column. BEFORE procedures must be done before you operate or use the equipment for its intended mission. DURING procedures must be done during the time you are operating or using the equipment for its intended mission. AFTER procedures must be done immediately after you have operated the equipment.

2.2.2.3 Location and Item to Check/Service Column. This column provides the location and the item to be checked or serviced. The item location is underlined.

2.2.2.4 Procedure Column. This column gives the procedure you must do to check or service the item listed in the Check/Service column to know if the equipment is ready or available for its intended mission or for operation. You must do the procedure at the time stated in the interval column.

2.2.2.5 Not Fully Mission Capable if: Column. Information in this column tells you what faults will keep your equipment from being capable of performing its primary mission. If you make check and service procedures that show faults listed in this column, do not operate the equipment. Follow standard operating procedures for maintaining the equipment or reporting equipment failure.

2.2.3 Other Table Entries. Be sure to observe all special information and notes that appear in your table.

2.2.4 Special Instructions. Preventive maintenance is not limited to performing only those checks and services listed in the PMCS Table. Covering unused receptacles, stowing unused accessories, and other routine procedures such as equipment inventory, cleaning components, and touch-up painting are not listed in the table. These are things you should do any time you see that they need to be done. If a routine check is listed in the PMCS Table, it is because experience has shown that problems may occur with this item. Take along tools and cleaning cloths needed to perform the required checks and services.

2.2.5 Leakage Definitions. Leakage definitions operator/crew PMCS are classified as follows:

- Class I Seepage of fluid (indicated by wetness or discoloration) not great enough to form drops.
- Class II Leakage of fluid great enough to form drops but not enough to cause drops to drip from item being checked.
- Class III Leakage of fluid great enough to cause drops to drip from item being checked.

NOTE

- The TWDS can be operated with Class I and Class II leaks. When in doubt notify supervisor of leak.
- Do not operate TWDS with a Class III leak. Class III leaks must be reported to your supervisors or to Unit Level Maintenance for corrective action.
- If the equipment must be kept in continuous operation, do only the procedures that can be done without disturbing operation. Make the complete checks and services when the equipment can be shutdown.

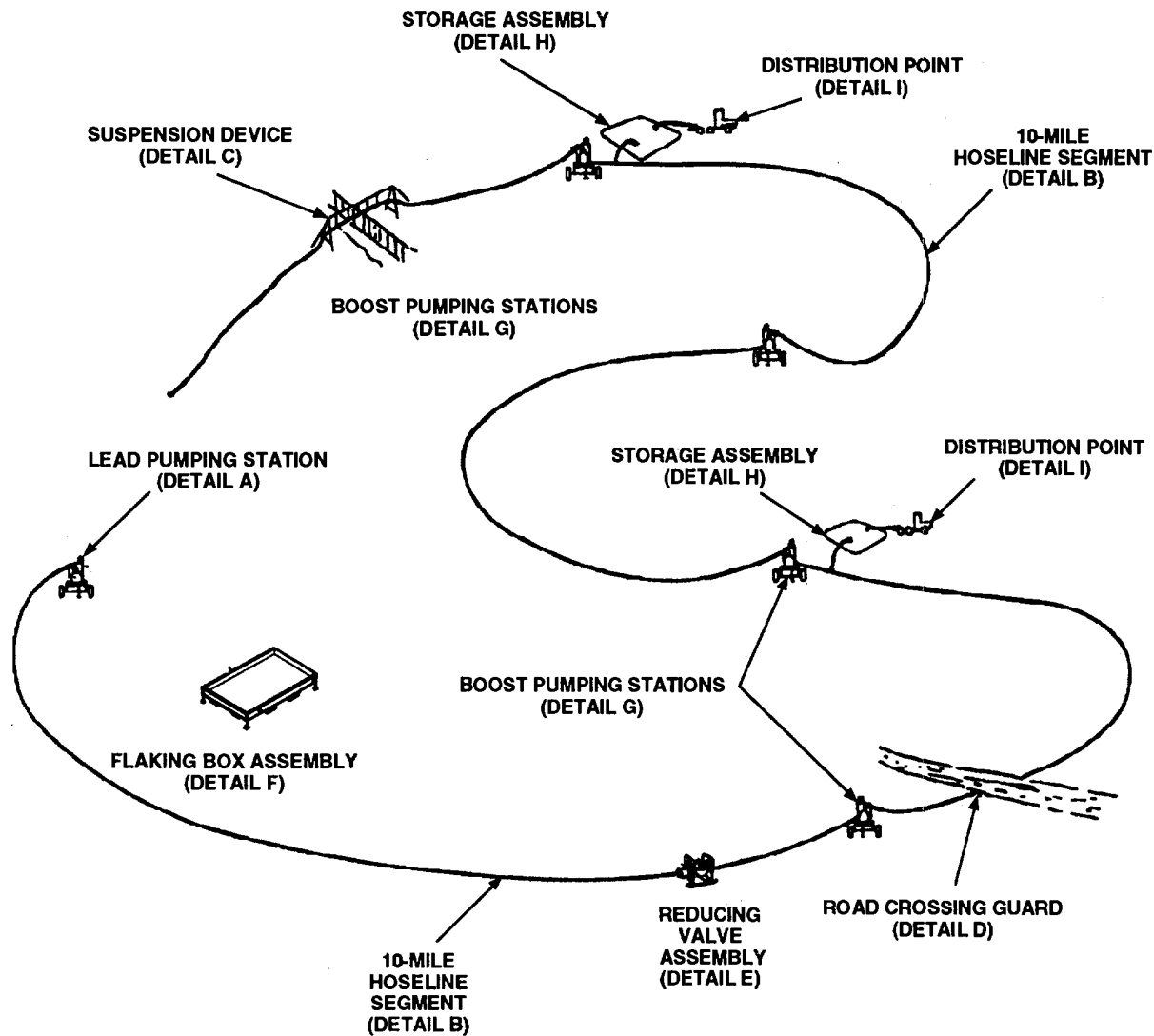
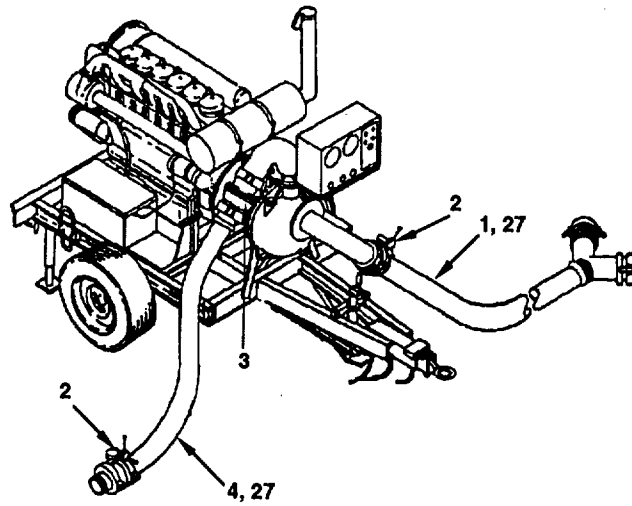


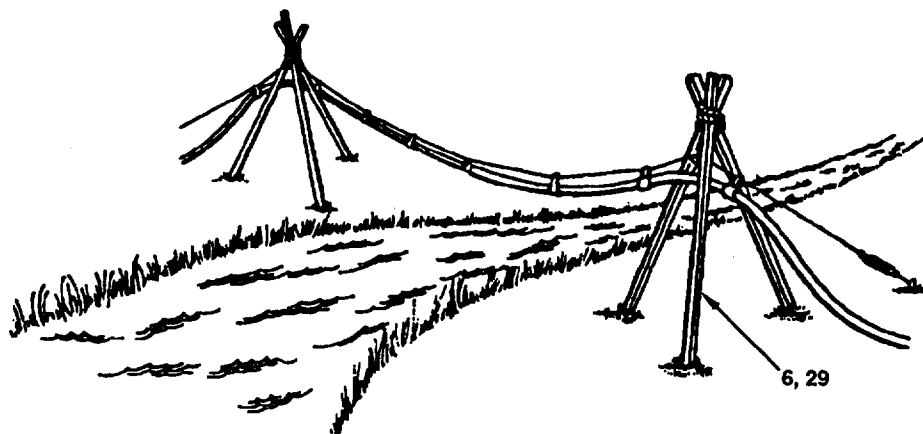
Figure 2-7. Operator PMCS Routing Diagram (Sheet 1 of 5).



DETAIL A



DETAIL B



DETAIL C

Figure 2-7. Operator PMCS Routing Diagram (Sheet 2 of 5).

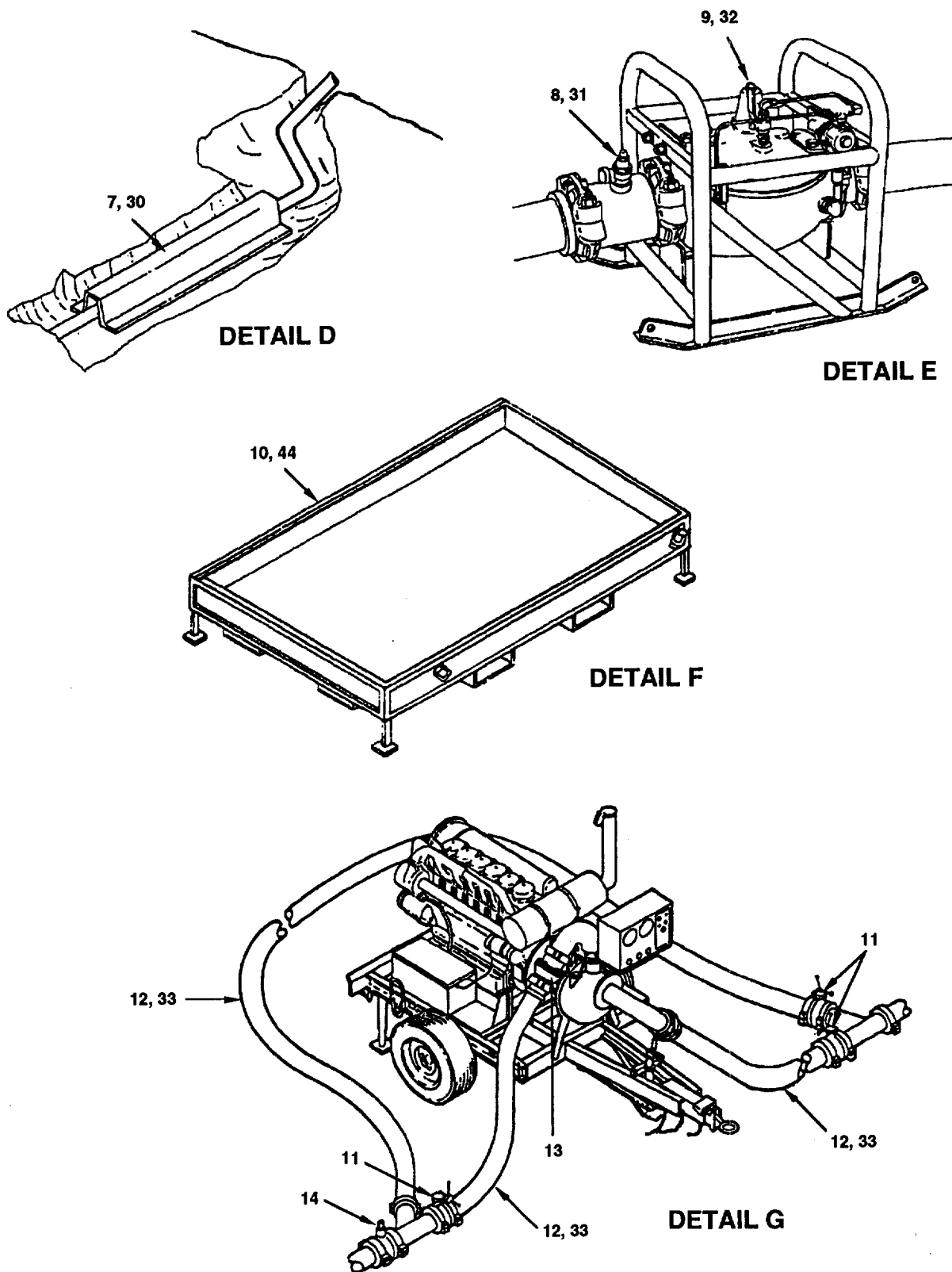


Figure 2-7. Operator PMCS Routing Diagram (Sheet 3 of 5).
2-12

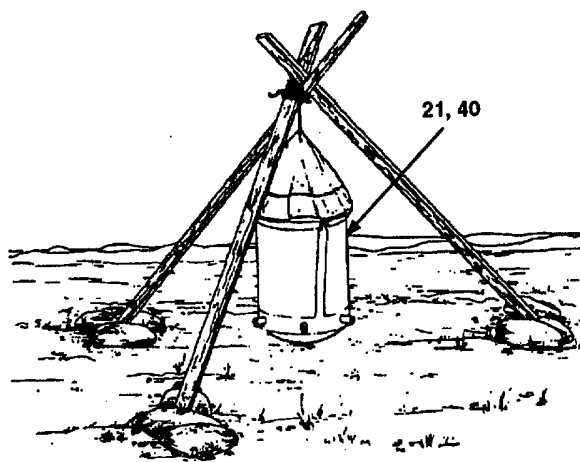
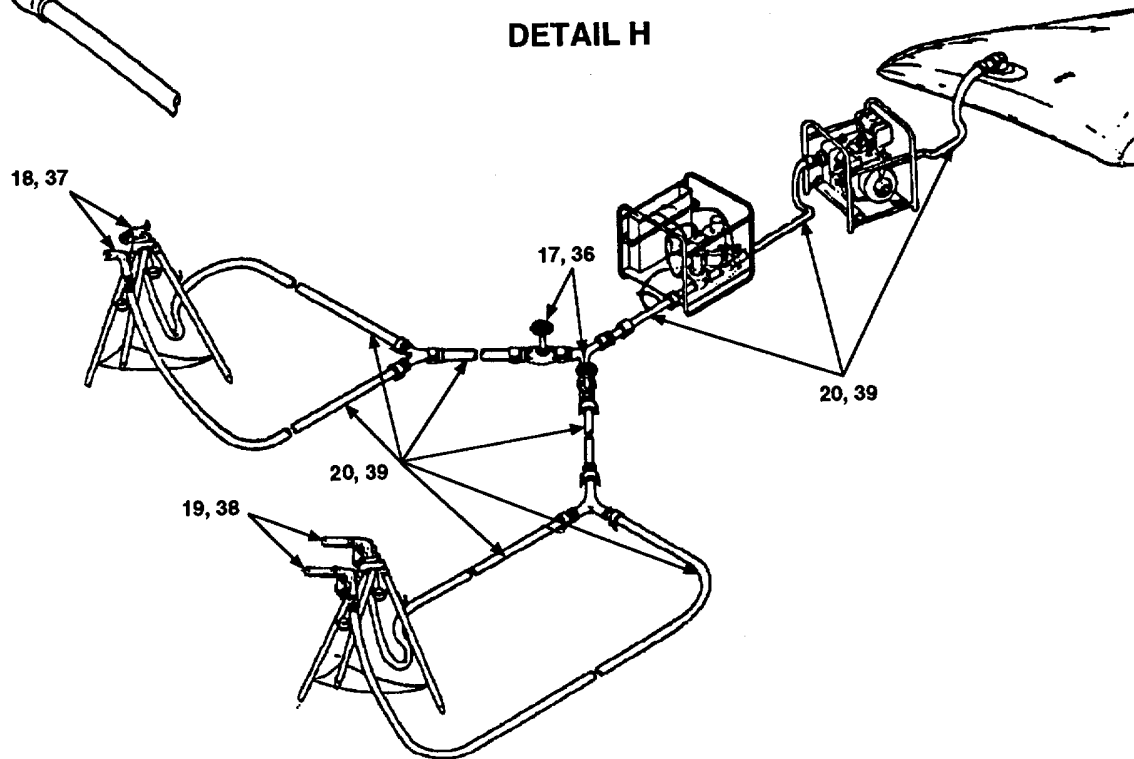
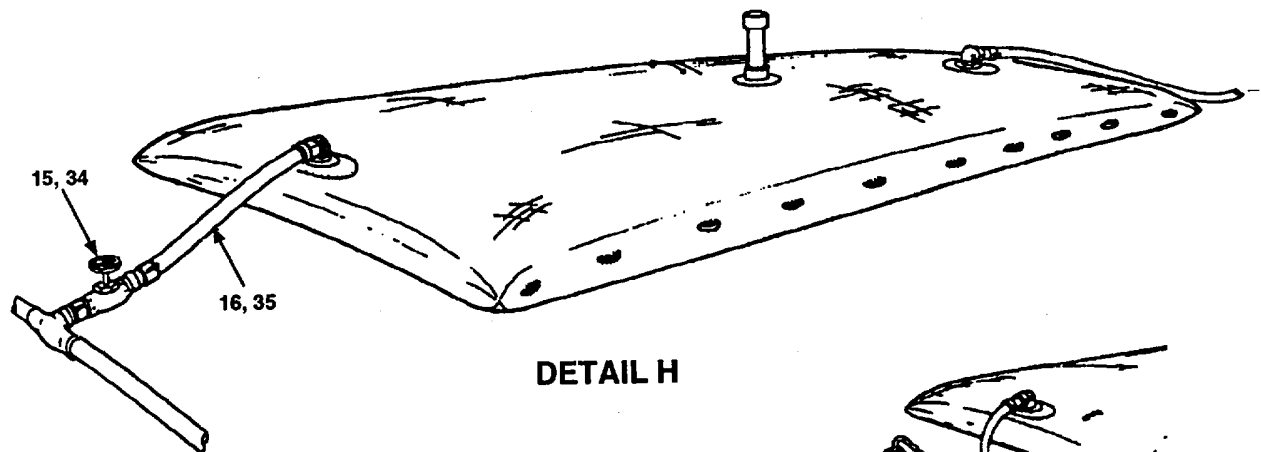
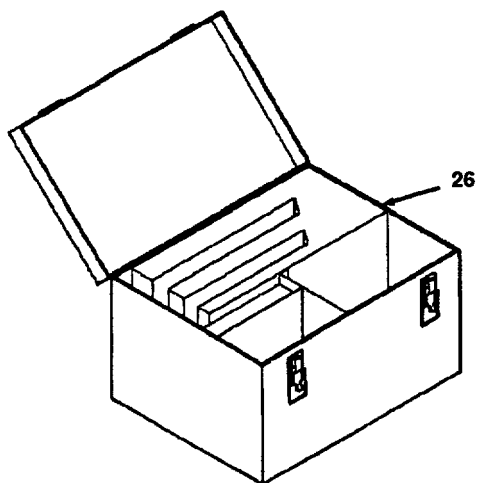
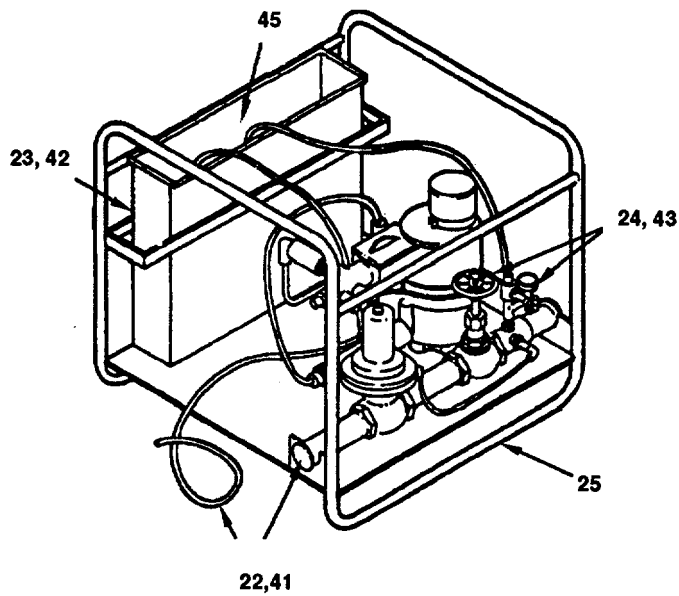


Figure 2-7. Operator PMCS Routing Diagram (Sheet 4 of 5).



DETAIL I (continued)

Figure 2-7. Operator PMCS Routing Diagram (Sheet 5 of 5).

Table 2-7. Operator Preventive Maintenance Checks and Services for TWDS.

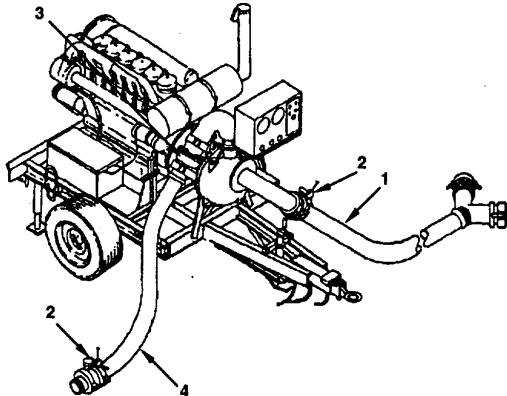
Item No.	Interval	Location	Procedure	Not Fully Mission Capable if:
		Item to Check/Service		
		<u>LEAD PUMPING STATION</u>		
				
1	Before	Suction Hose Assembly	Inspect for damage, leaks, and loose connections. Tighten loose connections. If hose is damaged or Class III leaks are present, notify supervisor.	Hose is damaged or collapsed. Class III leak. Connection is loose.
2	Before	6 Inch Butterfly Valve	Ensure butterfly valves on hose assemblies are in open position. If valve will not open, notify supervisor. Ensure butterfly valve on bypass hose assembly is closed when not in use. If valve will not close, notify supervisor.	Valve on suction and discharge hoses will not fully open. Valve on bypass hose assembly is open.
3	Before	Check Valve	Ensure check valve is installed properly. Arrow on body casing must point in direction of water flow. If valve is not installed correctly notify supervisor. Inspect for leakage and loose connections. Tighten loose connections. If Class III leak is present, notify supervisor.	Check valve is not installed properly. Connection is loose. Class III leak.
4	Before	Discharge Hose Assembly	Inspect for damage, leaks, and loose connections. Tighten loose connections. If hose is damaged or Class III leak is present, notify supervisor.	Hose is damaged or collapsed. Class III leak. Connection is loose.

Table 2-7. Operator Preventive Maintenance Checks and Services for TWDS. (Continued)

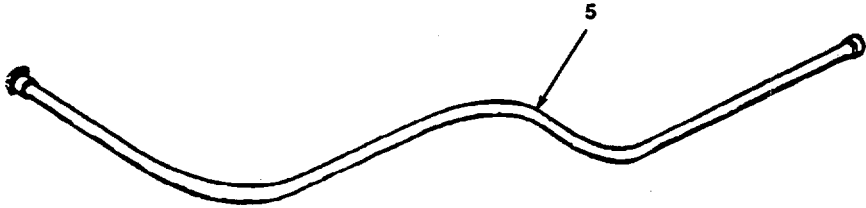
Item No.	Interval	Location	Procedure	Not Fully Mission Capable if:
		Item to Check/Service		
5	Before	<p><u>10-MILE HOSELINE STATION</u> 6 Inch x 500 Foot Hose Assembly</p>	<p>Inspect for damage, leaks, kinks, twists, and loose connections. Tighten loose connections. If hose is damaged or Class III leaks are present, notify supervisor. Inspect for rubbing or chafing against trees, rocks, suspension device tripods, or other objects that might damage hoseline. Reposition hose as required.</p>	<p>Hose is damaged. Class III leak. Connection is loose, kinked or twisted.</p>
				
<p>WARNING</p> <p>Suspension wire for hose assembly is under tension. Death or personal injury may result if care is not used. Always wear helmet and gloves while working with suspension components.</p>				
6	Before	Suspension Device	<p>Inspect for damage. Inspect security of suspended hoseline. Inspect for damaged or broken saddle assemblies. Ensure saddles are spaced at 5 foot intervals. Inspect wire rope for damage and fraying. Ensure wire rope is securely anchored.</p>	<p>Suspension device damaged or suspended hoseline not secure. Saddle assemblies damaged or broken. Wire rope damaged, frayed, or not securely anchored.</p>

Table 2-7. Operator Preventive Maintenance Checks and Services for TWDS. (Continued)

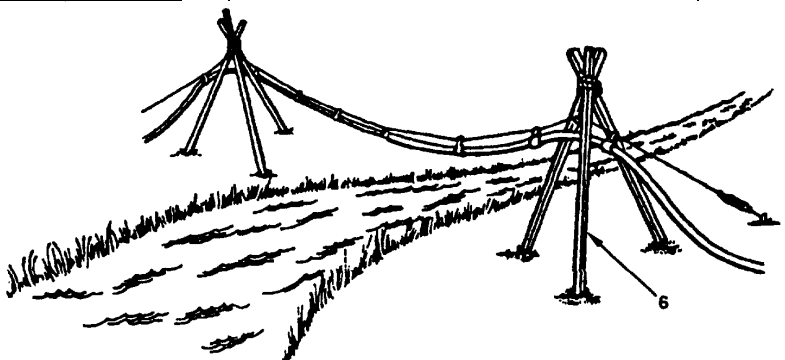
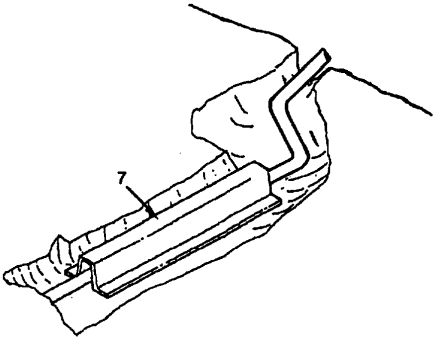
Item No.	Interval	Location	Procedure	Not Fully Mission Capable if:	
		Item to Check/Service			
		<u>10-MILE HOSELINE STATION-CONT</u>			
					
7	Before	Road Crossing Guard	Ensure road crossing guards are providing protection for the hose line. If road crossing guard has collapsed or hose line is damaged, notify supervisor.	Road crossing guard is not providing protection to the hose line.	
					
8	Before	Pressure Relief Valve	Inspect valve for presence of grit, sand, or dirt. If dirty, clean using soft brush. Inspect for damage or leaks. If damaged or Class III leaks are present, notify supervisor.	Dirty pressure relief valve. Pressure relief valve damaged. Class III leak.	
9	Before	Pressure-Reducing Valve Assembly	Inspect skid for cracks and damaged welds. Inspect valves, lines, and assembly for damage and leaks. If skid is damaged, valves are damaged, or Class III leaks are present, notify supervisor. Make sure isolation cock valves are open.	Skid has cracks or damaged welds. Valve and lines are damaged. Isolation cock valve(s) is closed. Class III leak.	

Table 2-7. Operator Preventive Maintenance Checks and Services for TWDS. (Continued)

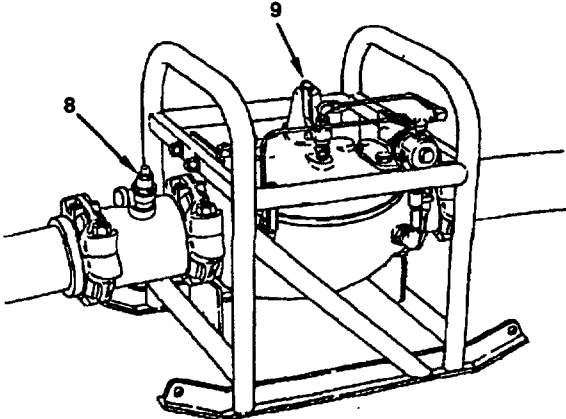
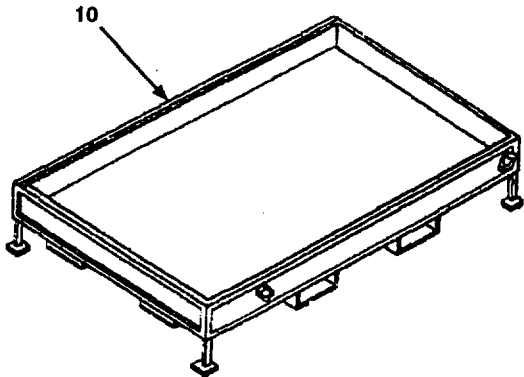
Item No.	Interval	Location	Procedure	Not Fully Mission Capable if:
		Item to Check/Service		
		<u>10-MILE HOSELINE STATION-CONT</u>		
				
10	Before	Flaking Box <u>BOOST PUMPING STATION</u>	Inspect all frame seam welds for cracking and damage. Inspect lifting devises and clevis attach brackets for cracks, bends, or broken seam welds. Inspect tailgate assembly, side walls, and base for damage. If any of these items are damaged, notify supervisor.	Seam weld is damaged. Lifting clevis or clevis attach bracket are damaged. Tailgate assembly is damaged.
				
11	Before	6 Inch Butterfly Valve	Ensure butterfly valves on hose assemblies move freely.	Valves do not move freely.

Table 2-7. Operator Preventive Maintenance Checks and Services for TWDS. (Continued)

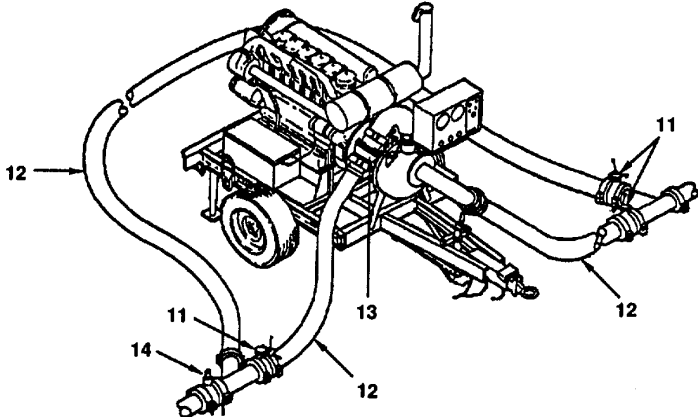
Item No.	Interval	Location	Procedure	Not Fully Mission Capable if:
		Item to Check/Service		
		<u>BOOST PUMPING STATION-CONT</u>		
12	Before	Hose Assemblies	Inspect for damage, leaks, and loose connections. Tighten loose connections. If hose is damaged or Class III leaks are present, notify supervisor.	Class III three leaks.
13	Before	Check Valve	Ensure check valve is installed properly. Arrow on body casing must point in direction of water flow. Inspect for leakage and loose connections. Tighten loose connections.	Check valve is not installed properly. Connection is loose. Class III leaks.
14	Before	Pressure Relief Valve	Inspect valve for presence of grit, sand, or dirt. If dirty, clean using soft brush. Inspect for damage or leaks.	Dirty pressure relief valve. Pressure relief valve damaged. Class III leak. If discharge port is obstructed.
		<u>STORAGE ASSEMBLY</u>		
				
15	Before	4 Inch Gate Valve	Inspect for damage and improper operation. Check to be sure valve turns freely. Check for leaks.	4 inch gate valve is damaged or does not turn freely. Class III leak.
16	Before	4 Inch x 10 Foot Discharge Hose	Inspect for damage, leaks, and loose connections. Tighten loose connections.	Hose is damaged. Class III leak. Connection is loose.

Table 2-7. Operator Preventive Maintenance Checks and Services for TWDS. (Continued)

Item No.	Interval	Location	Procedure	Not Fully Mission Capable if:
		Item to Check/Service		
		<u>DISTRIBUTION POINT</u>		
17	Before	2 Inch Gate Valve	Inspect for damage, leaks, and turns freely. If valve is leaking, damaged, or not operating properly, notify supervisor.	2 inch gate valve is damaged. Class III leak. Valve does not rotate freely.
18	Before	Elbow Valve	Inspect for damage, leaks, and improper operation. Inspect for damaged or missing gasket. If valve is damaged, not operating properly, or Class III leaks are present, notify supervisor.	Elbow valve is damaged or not operating properly. Class III leak. Damaged or missing gasket.
19	Before	Nozzle	Inspect for damage and leaks. Ensure triggers work properly.	Nozzle is damaged. Class III leak. Trigger is not properly
20	Before	Distribution Point Hose Assemblies	Inspect for damage and leaks. If hose is damaged or Class III leaks are present, notify supervisor.	operating. Connection is loose. Hose is damaged. Class III leak.

Table 2-7. Operator Preventive Maintenance Checks and Services for TWDS. (Continued)

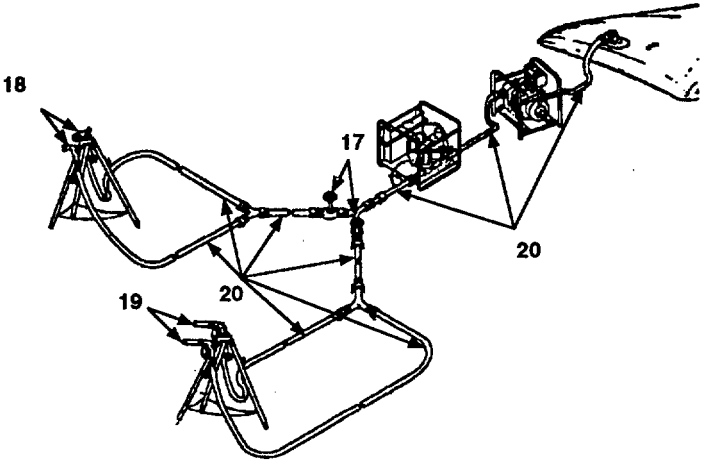
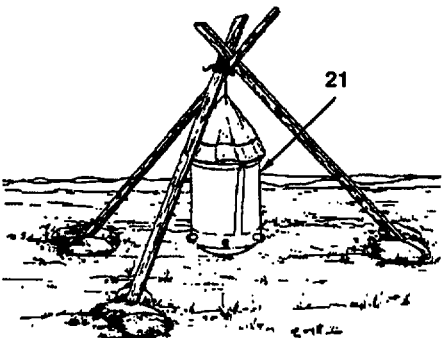
Item No.	Interval	Location	Procedure	Not Fully Mission Capable if:
		Item to Check/Service		
		<u>DISTRIBUTION POINT-CONT</u>		
				
21	Before	Water Storage Bag <u>HYPOCHLORINATION UNIT MODEL 1955-1</u>	Inspect bag and faucets for damage and leaks. Ensure bag has adequate support.	Water storage bag or faucet is damaged. Class III leak. Water storage bag does not have enough support.
				
22	Before	Pipes and Tubes	Inspect pipes, tubes, and connections for damage and leaks.	Pipe(s), tube(s), or connection(s) are damaged. Class III leak.

Table 2-7. Operator Preventive Maintenance Checks and Services for TWDS. (Continued)

Item No.	Interval	Location	Procedure	Not Fully Mission Capable if:
		Item to Check/Service		
23	Before	<u>DISTRIBUTION POINT HYPOCHLORINATION UNIT MODEL 1955-1-CONT</u>		Reservoir is damaged or has a Class III leak. Not enough solution in reservoir. Foot valve obstructed. Valve(s) is damaged, class III leak, or does not turn freely.
		Solution Reservoir	Inspect for damage and leaks. Check solution level. Add solution as required (para 2.5.5.3). Inspect foot valve for obstruction.	
		Valves	Inspect valves for damage, leaks, and improper operation. Check to be sure valve turns freely.	
24	Before	Frame	Inspect frame for cracks, damaged welds, and corrosion.	
<u>TWDS SUPPORT KITS</u>				
26	Before	TWDS Support Kits	Inspect displacement and evacuation, packing, repair, and suspension kits for damage. Inspect each kit for damaged or missing items. Ensure items in each kit are clean and dry. Inspect latches, hinges, lid, and box on each kit for damage.	Item in kit is damaged or missing.

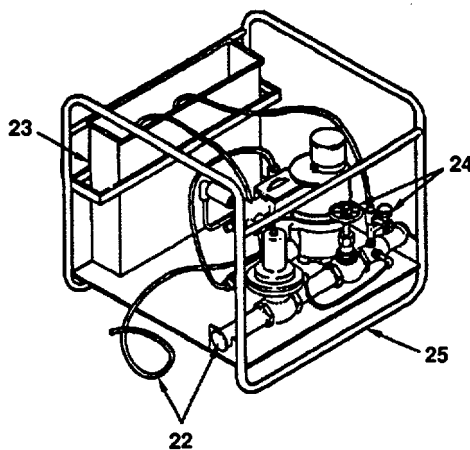


Table 2-7. Operator Preventive Maintenance Checks and Services for TWDS. (Continued)

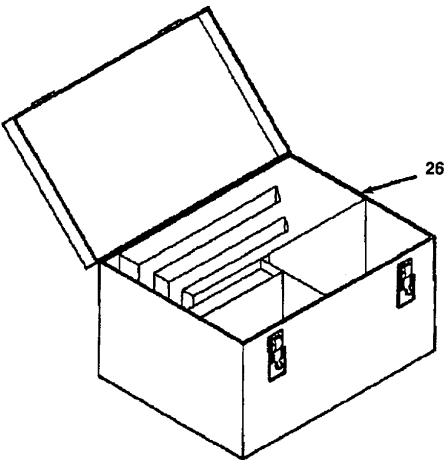
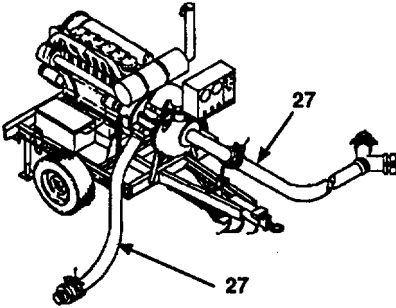
Item No.	Interval	Location	Procedure	Not Fully Mission Capable if:
		Item to Check/Service		
		<u>LEAD PUMPING STATION</u>		
				
27	During	Hose Assemblies <u>10-MILE HOSELINE SEGMENT</u>	Inspect for damage, leaks, and loose connections. Tighten loose connections. If hose is damaged or Class III leaks are present, notify supervisor.	Hose is damaged or collapsed. Class III leak. Connection is loose.
				
28	During	6 Inch x 500 Foot Hose Assembly	Inspect for damage, leaks, and loose connections. Tighten loose connections. Inspect for kinks, twists, rubbing or chafing against trees, rocks, suspension device tripods, or other objects that might damage hoseline. Reposition hose as required.	Hose is damaged or class III leak. Connection is loose.

Table 2-7. Operator Preventive Maintenance Checks and Services for TWDS. (Continued)

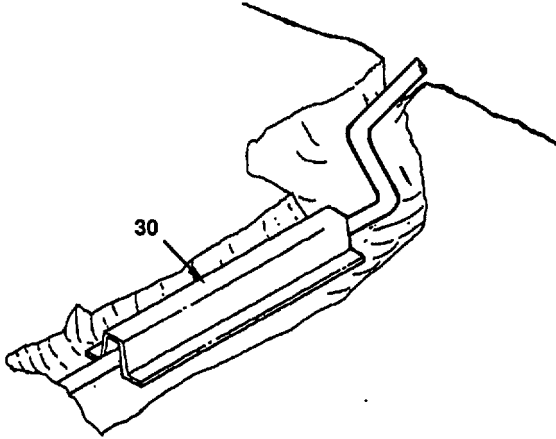
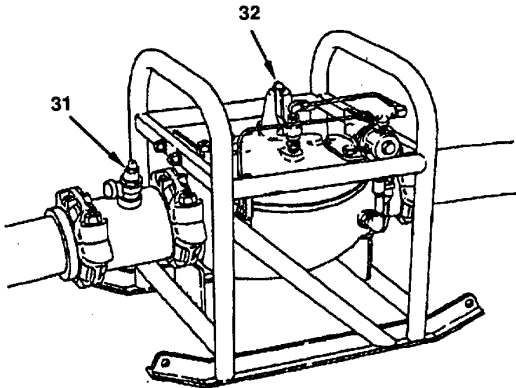
Item No.	Interval	Location	Procedure	Not Fully Mission Capable if:
		Item to Check/Service		
		<u>10-MILE HOSELINE STATION-CONT</u>		
				
31	During	Pressure Relief Valve	Inspect valve for presence of grit, sand, or dirt. If dirty, clean using soft brush. Inspect for damage or leaks. If damaged or Class III leaks are present, notify supervisor.	Dirty pressure relief valve. Pressure relief valve damaged or Class III leak.
32	During	Pressure-Reducing Valve Assembly	Inspect skid for cracks and damaged welds. Inspect valves, lines, and assembly for damage and leaks. If skid is damaged, valve is damaged, or Class III leaks are present, notify supervisor. Make sure isolation cock valves are open.	Skid has crack or damaged welds. Valve and lines are damaged. Isolation cock valve(s) is closed. Class III leak.
		<u>BOOST PUMPING STATION</u>		
				

Table 2-7. Operator Preventive Maintenance Checks and Services for TWDS. (Continued)

Item No.	Interval	Location	Procedure	Not Fully Mission Capable if:
		Item to Check/Service		
33	During	<p><u>BOOST PUMPING STATION-CONT</u> Hose Assemblies</p> <p><u>STORAGE ASSEMBLY</u></p>	<p>Inspect for damage, leaks, and loose connections. Tighten loose connections. If hose is damaged or Class III leak is present, notify supervisor.</p>	<p>Hose is damaged, collapsed, or leaking. Connection is loose.</p>
34	During	4 Inch Gate Valve	<p>Inspect for damage, improper operation, and leaks. If valve is damaged or not operating properly, notify unit maintenance. If Class III leaks are present, notify supervisor.</p>	<p>4 inch gate valve is damaged or not operating properly. Class III leak.</p>
35	During	4 Inch x 10 Foot Hose Assembly	<p>Inspect for damage, leaks, and loose connections. Tighten loose connections. If hose is damaged or Class III leaks are present, notify supervisor.</p>	<p>Hose is damaged or leaking. Class III leak. Connection is loose.</p>

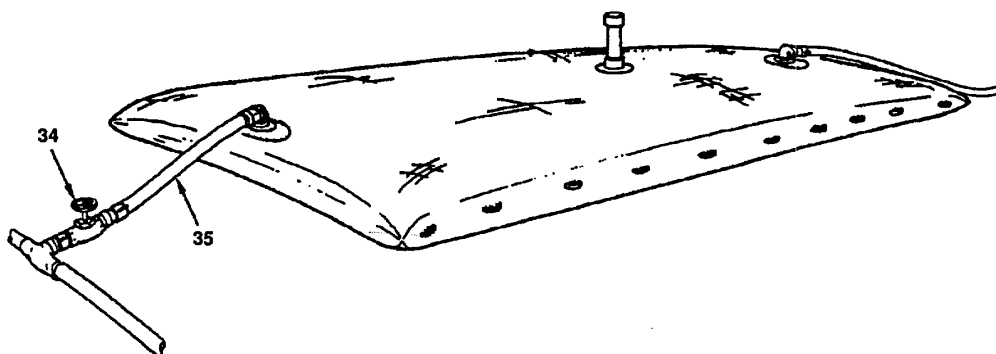
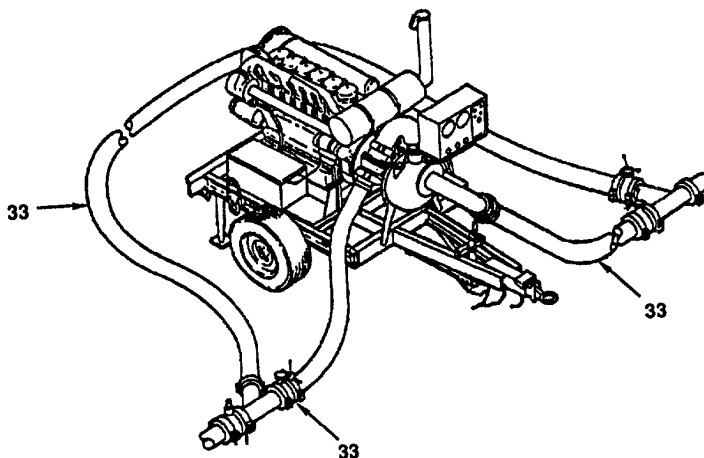


Table 2-7. Operator Preventive Maintenance Checks and Services for TWDS. (Continued)

Item No.	Interval	Location	Procedure	Not Fully Mission Capable if:
		Item to Check/Service <u>DISTRIBUTION POINT</u>		
36	During	2 Inch Gate Valve	Inspect for damage, leaks, and improper operation. If valve is damaged, not operating properly, or Class III leaks are present, notify supervisor.	2 inch gate valve is damaged or not operating properly. Class III leak.
37	During	Elbow Valve	Inspect for damage, leaks, and improper operation. If valve is damaged, not operating properly, or Class III leaks are present, notify supervisor.	Elbow valve is damaged or not operating properly. Class III leak.
38	During	Nozzle	Inspect for damage and leaks. Ensure triggers work properly. If nozzle is damaged, trigger is not working properly, or Class III leak is present, notify supervisor.	Nozzle is damaged. Trigger is not properly operating. Class III leak.

Table 2-7. Operator Preventive Maintenance Checks and Services for TWDS. (Continued)

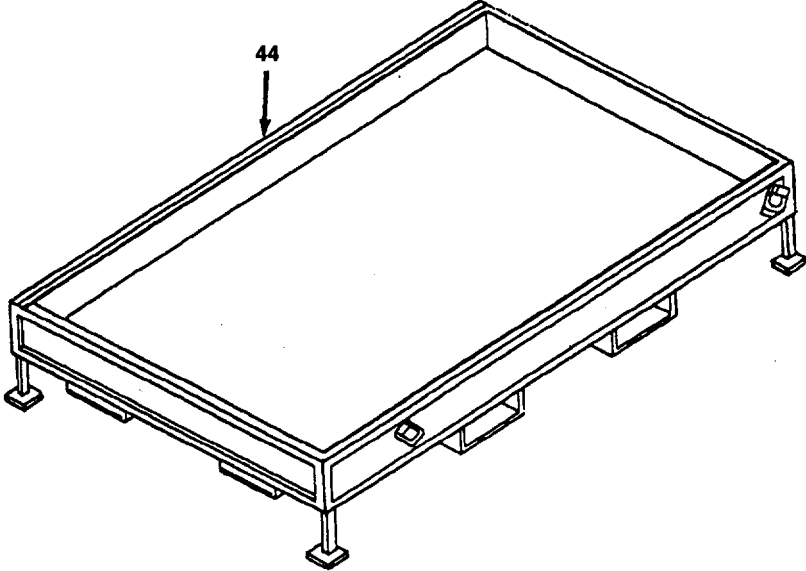
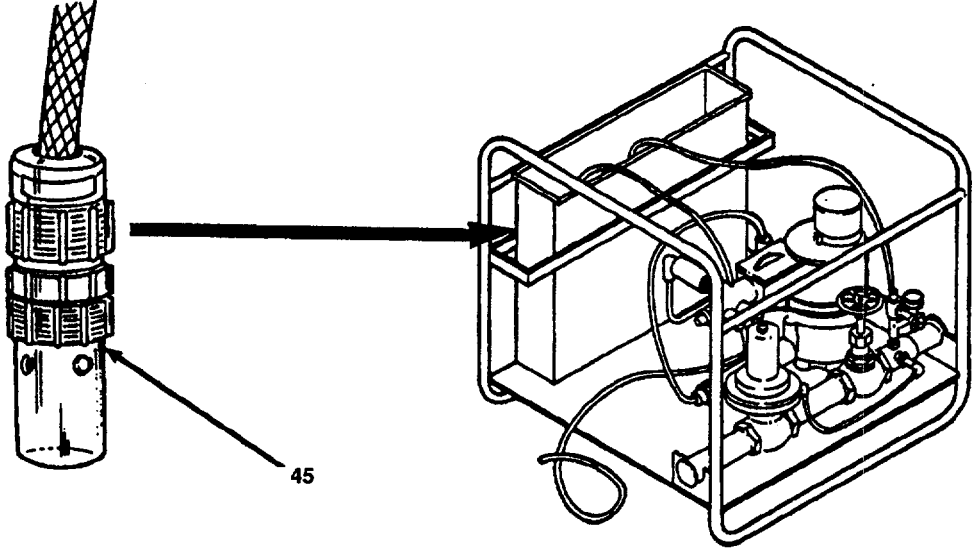
Item No.	Interval	Location	Procedure	Not Fully Mission Capable if:
		Item to Check/Service		
42	During	<u>DISTRIBUTION POINT HYPOCHLORINATION UNIT MODEL 1955-1 - CONT</u> Solution Reservoir	Inspect for damage and leaks. Check solution level. Add solution as required (para 2.5.5.3). If damaged or Class III leak is present, notify supervisor. Inspect valves for damage, leaks, and improper operation. If valve is damaged, operating improperly, notify unit maintenance. If Class III leak is present, notify supervisor.	Reservoir is damaged. Not enough solution in reservoir. Class III leak.
43	During	Valves		
		<u>10-MILE HOSELINE SEGMENT FLAKING BOX</u>		
				
44	After	Flaking Box	Inspect all frame seam welds for damage. Inspect lifting devices and clevis attach brackets for cracks, bends, or broken seam welds. Inspect tailgate assembly, side walls, and base for damage.	Seam weld is damaged. Lifting clevis or clevis attach bracket is damaged. Tailgate assembly is damaged.

Table 2-7. Operator Preventive Maintenance Checks and Services for TWDS. (Continued)

Item No.	Interval	Location Item to Check/Service	Procedure	Not Fully Mission Capable if:
45	Daily	<u>DISTRIBUTION POINT HYPOCHLORINATION UNIT MODEL 1955-1</u> 	Flush hypochlorination unit with clean water. Refer to paragraph 2.8.6.2 and flush hypochlorination unit.	

SECTION III. OPERATION UNDER USUAL CONDITIONS

2.3 ASSEMBLY AND PREPARATION FOR USE.

2.3.1 TWDS Site Location and Pumping Station Spacing.

2.3.1.1 Terrain Survey. Prior to installing TWDS equipment, a thorough study of the terrain is required. A general route for hoseline and general locations for the pumping stations, storage assemblies, and distribution points can be determined from examination and comparison of maps, photographs, and charts. Some elements to be considered in selecting a route and installation sites for TWDS are:

- Whether TWDS will operate independently or as part of a large system.
- TWDS assigned mission (i.e., dispensing, storing, or transferring water).
- Expected length of time TWDS will be required to operate.
- Elevation differences and distances TWDS will encounter along its route.

2.3.1.2 Pumping Station, Storage Assembly, and Distribution Point Location Reconnaissance.

Organize a ground reconnaissance prior to installation of TWDS to determine exact locations for pumping stations, storage assemblies, and distribution points. If possible, site locations should be near or parallel to

existing roads to ease transportation, assembly, inspection, maintenance, and disassembly of TWDS. Avoid routes along the banks of streams, marshes, ponds, gullies, ravines, or other areas subject to flooding. Whenever possible, the hoseline should be laid out on firm, dry level ground that allows easy access and is not subject to flooding.

2.3.1.3 Minimum Route Selection Requirements. Ensure minimum requirements necessary for route selection are available when selecting a route for the TWDS. The minimum requirements for selecting the route are as follows:

- A sketch of the proposed hoseline route.
- Odometer distances.
- Enough topographic information (surveying altimeter elevations) to establish relative altitude at various points along the hoseline route.

2.3.1.4 TWDS Installation and Operation Guidelines. The following guidelines should be utilized to gain maximum effectiveness for installation and operation of TWDS:

- The route should be direct and present a minimum number of obstacles and obstructions.
- A route parallel to a secondary all-weather road is preferable to one along a heavily traveled road.
- If roadways do not exist or cannot be utilized, select a route that is accessible to vehicles required for laying the hoseline.
- Plan to locate junction of two hoseline lengths at installation sites for each boost pumping station and storage assembly.
- Keep security precautions in mind. Utilize natural camouflage wherever possible and avoid routing hoseline through populated areas.

2.3.1.5 Pumping Station Installation Sight Selection. When selecting pumping station installation sites, the location of the lead or first pumping station will be determined by location of the water source. Boost pumping stations are intended to be spaced at approximately two mile intervals, assuming that the route is reasonably direct and the terrain is level. However, a substantial rise or fall in elevation along the hoseline route may require adjustment of standard spacing intervals between pumping stations. When substantial rise or fall in elevation occurs between two consecutive pumping stations the following pumping station movements must be performed:

- If the next downline pumping station is substantially higher in elevation than the upline pumping station, decrease distance between pumping stations.
- If the next down line pumping station is substantially lower in elevation than the upline pumping station, increase distance between pumping stations.

Adjusting distance between pumping stations when elevation changes occur assures that water pressure will be maintained within optimum operational range. Under normal conditions, TWDS will deliver water to the suction port of each boost pumping station at a pressure of 20 pounds per square inch gage (psig). Whenever pressure falls below 20 psig, boost pumping station pumping assemblies are designed to begin reducing speed, when operated in the electric automatic mode. Therefore, if an upline pumping station is substantially lower than the next down line station, and the elevation difference has not been offset by spacing adjustment between pumping stations, suction pressure at the down line pumping station may fall below 20 psig and cause that pump to slow down. This in turn will cause remaining down line boost pumping stations to slow down, seriously degrading overall TWDS performance.

2.3.1.6 Ground Profile and Pump Spacing Triangle. A ground profile (drawn on graph paper) and a pump spacing triangle can be utilized to determine the location of each boost pumping station. Proper construction and use of the ground profile and pump spacing triangle will ensure that the installed TWDS will perform within its' optimal range.

2.3.1.6.1 Ground Profile Construction. To construct a ground profile, first obtain a topographical map or other source material providing accurate information concerning terrain along projected hoseline route. Then, using this information, draw a ground profile of the hoseline route on graph paper as follows:

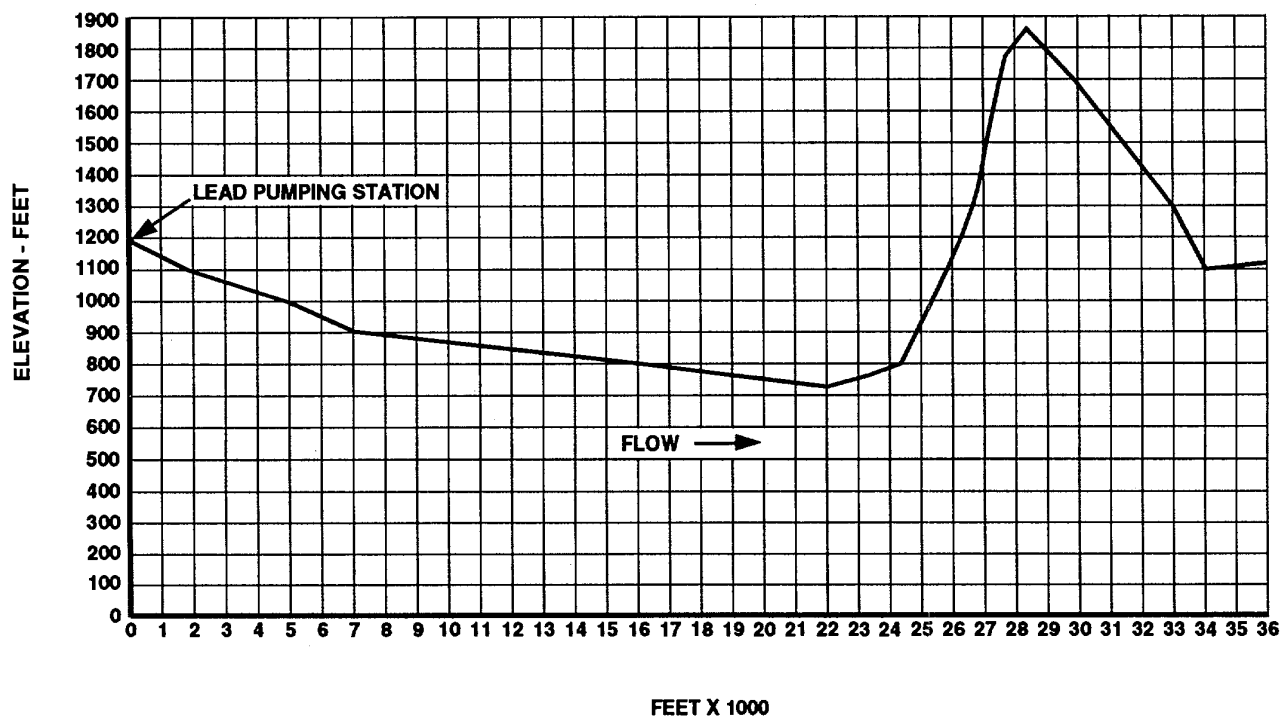


Figure 2-8. Ground Profile.

- a. Divide horizontal base of ground profile graph, Figure 2-8, into spaces that represent uniform distances, such as 1,000 foot intervals. However, any suitable scale can be used. The ground profile base represents the horizontal distance the hoseline will cross.
- b. Divide vertical, left-hand edge of ground profile graph into spaces that represent uniform changes in elevation, such as 100 feet intervals. Again, any suitable scale can be used. However, the scale must include at least the highest and lowest elevations along the hoseline route.
- c. At left-hand edge of ground profile graph, mark a point that represents lead pumping station elevation.
- d. Continuing across ground profile graph, mark points where significant changes in elevation occur along hoseline route.
- e. To complete ground profile, join the points marked on the ground profile graph with a straight line.

2.3.1.6.2 Pump Spacing Triangle Construction. To construct a spacing triangle, obtain a piece of paper, transparent sheet, or cardboard thick enough to be used as a straightedge. Then prepare the pump spacing triangle as follows:

- a. Divide horizontal base of pump spacing triangle, Figure 2-9, into spaces on the same uniform scale used to divide the ground profile graph base. Mark off spaces along pump spacing triangle base to at least 39,000 feet.

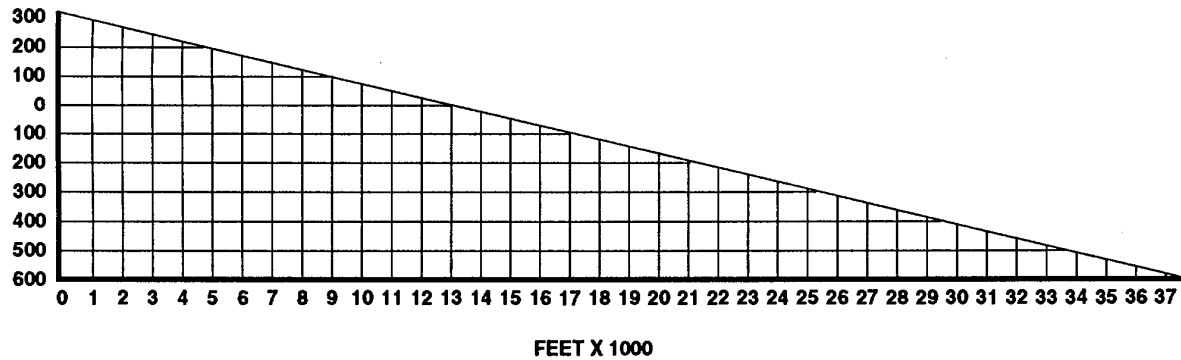


Figure 2-9. Pump spacing Triangle.

- b. Divide vertical, left-hand edge of pump spacing triangle into spaces on the same uniform scale used to represent elevation changes on ground profile graph. Mark off spaces along vertical side of pump spacing triangle as follows:
 - (1) Zero represents pumping station elevation.
 - (2) The upper left-hand corner represents 300 feet above pumping station.
 - (3) The lower left-hand corner represents 600 feet below pumping station.
- c. Draw a straight, diagonal line from the 300 feet mark on the vertical scale to the 39,000 feet mark on the horizontal scale. This line will form the hypotenuse or long side of the triangle.
- d. Making sure all lines have a straight edge, cut the triangle along the three sides drawn (horizontal, vertical, and diagonal).

2.3.1.7 Determining Location of First Boost Pumping Station. Using ground profile graph and pump spacing triangle, refer to figure 2-10 and determine first boost pumping station as follows:

- a. Place pump spacing triangle on ground profile graph.
- b. Align vertical side of pump spacing triangle with vertical (elevation) side of ground profile graph. Ensure zero mark of pump spacing triangle is on lead pumping station mark of ground profile graph.
- c. Ensure horizontal side of spacing triangle is exactly parallel with horizontal base of ground profile graph. Horizontal space on both the pump spacing triangle and ground profile graph should be exactly aligned.

NOTE

If level of ground profile is below base of pump spacing triangle, extend pump spacing triangle hypotenuse line until it crosses the ground profile.

- d. Mark point at which the hypotenuse (long side of pump spacing triangle) crosses ground profile. This will be the first boost pumping station location.

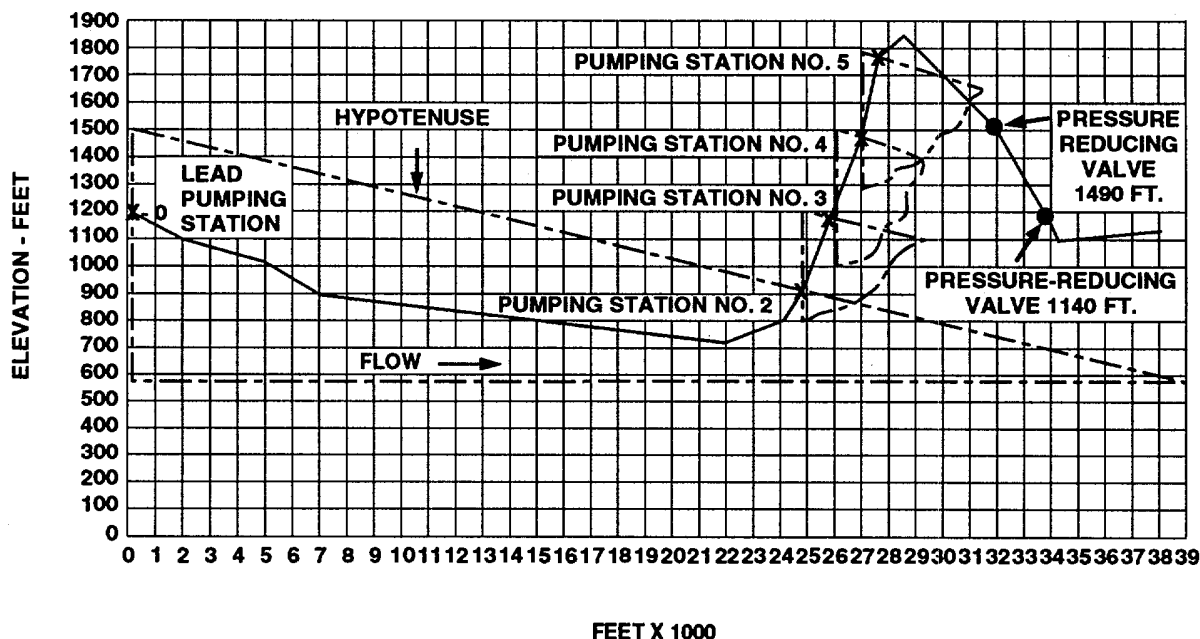


Figure 2-10. First Boost Pumping Station Location.

2.3.1.8 Determine Location of Second Boost Pumping Station. To determine second boost pumping station location, place pump spacing triangle zero mark on the first boost pumping station mark on ground profile graph. Mark point at which pump spacing triangle hypotenuse crosses ground profile. This identifies second boost pumping station location. Locations of successive boost pumping stations are determined using the same procedure.

2.3.1.9 Determine Location of Pressure-Reducing Valve Assembly. After locations of pumping stations have been plotted, check ground profile for any sharp declines in elevation along hoseline route. An excessive drop in elevation will significantly increase water pressure as water flows downhill.

CAUTION

To prevent damage to TWDS components do not allow water pressure to exceed 225 psig.

If pressure builds to 225 psig, hoseline can rupture and equipment failure will result. Therefore, when a sharp elevation drop along hoseline route -is indicated by the ground profile graph, a pressure-reducing valve assembly must be installed in the hoseline. To determine pressure-reducing valve assembly location, refer to ground profile graph and proceed as follows:

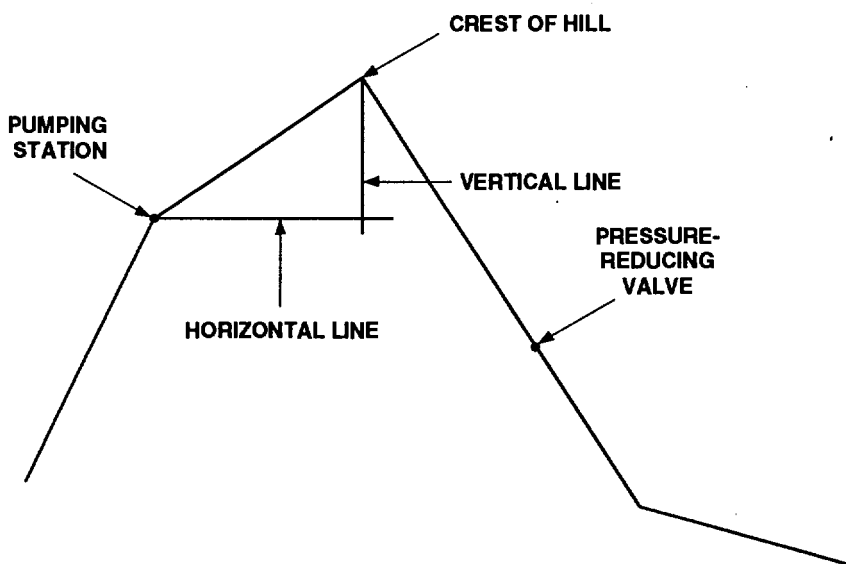


Figure 2-11. Pressure-Reducing Valve Assembly Location.

- a. Mark crest of hill on ground profile graph.
- b. Draw a vertical line downward from hill crest.
- c. Determine location of pumping station closest to hill crest (on uphill side).
- d. Draw a horizontal line outward from pumping station until it intersects the vertical line drawn in step b. above.
- e. Measure footage of horizontal line and footage of vertical line.
- f. Using formula provided below, determine total hoseline footage between pumping station and hill crest:

$$\text{Total hoseline footage} = \sqrt{a^2 + b^2}$$

where, a = horizontal line footage
 b = vertical line footage

- g. Using formula provided below, determine friction loss of total hoseline footage in terms of vertical feet:

$$\text{Total hoseline footage} \times 0.024 = \text{Vertical feet of friction loss in hoseline}$$

(0.024 = friction loss conversion factor)

- h. Using formula provided below, determine total feet of friction loss:

Vertical feet of friction loss in hoseline	+ Feet of elevation between pumping station and hill crest	= Total feet of friction loss
--	---	-------------------------------------

- i. Using formula provided below, convert total feet of friction loss into psi:

$$\frac{\text{Total feet of friction loss}}{2.31} = \text{friction loss in psi}$$

(2.31 = psi conversion factor)

2.3.1.9 Determine Location of Pressure-Reducing Valve Assembly. (Continued)

j. Using formula provided below, determine existing psi at hill crest:

$$150 \text{ psi} - \text{psi of friction loss} = \text{psi at hill crest}$$

(150 psi = pumping station discharge pressure)

k. Using formula provided below, determine allowed additional psi before safety limit is reached:

$$225 \text{ psi} - \text{psi at hill crest} = \text{Allowed additional psi before reaching safety limit}$$

(225 psi = safety limit pressure)

l. Using formula provided below, convert allowed additional psi into vertical feet:

$$\text{Allowed additional psi} \times 2.31 = \text{Allowed additional vertical footage before reaching safety limit}$$

(2.31 psi = vertical footage conversion factor)

m. Using formula provided below, determine point at which pressure-reducing valve assembly must be installed in hoseline:

$$\begin{array}{l} \text{Altitude at} \\ \text{hill crest} \end{array} - \begin{array}{l} \text{Allowed additional} \\ \text{vertical footage} \end{array} = \begin{array}{l} \text{Pressure-reducing valve} \\ \text{assembly installation} \\ \text{point} \end{array}$$

if elevation continues to drop excessively beyond first pressure-reducing valve assembly installation point, a second pressure-reducing valve assembly must be installed in hoseline. Using formula provided below, determine point at which next pressure-reducing valve assembly must be installed in hoseline:

$$\begin{array}{l} \text{altitude at first pressure-} \\ \text{reducing valve assembly} \\ \text{installation point} \end{array} - 346.5 = \begin{array}{l} \text{Second pressure-} \\ \text{reducing valve assembly} \\ \text{installation point} \end{array}$$

(346.5 = allowed additional vertical footage before reaching safety limit)

2.3.2 Grooved Pipe Coupling Removal and Installation . Remove and install grooved pipe coupling (Figure 2-12) as follows:

Tools

1-1/4, 1-1/16 inch wrench sockets and
Handle (Items 85, 86, and 146,
Appendix C)

Used To

Install 6 inch and 4 inch grooved
pipe couplings.

Personnel

Two required

NOTE

This is a general procedure for removal and installation of bolt secured model grooved pipe couplings. Follow this procedure when using a bolt secured model grooved pipe coupling to connect two TWDS components.

2.3.2.1 Removal

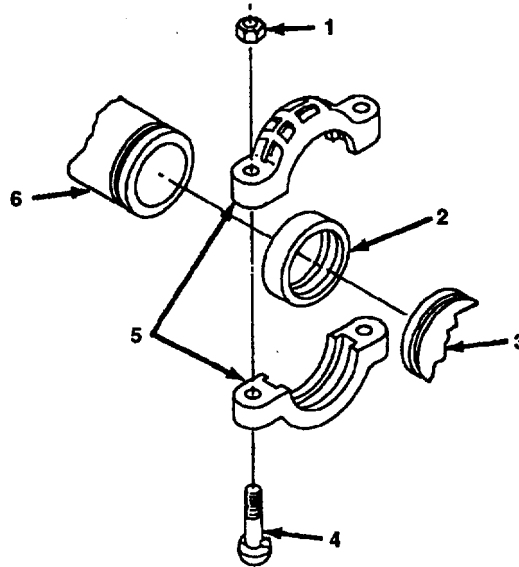


Figure 2-12. Grooved Pipe Coupling.

- a. Disassemble grooved pipe coupling by removing two nuts (Figure 2-12, 1), bolts (4), coupling halves (5), and gasket (2).
- b. Check gasket (2) for damage. If gasket (2) is damaged, replace it.

2.3.2.2 Installation.

- a. Apply thin coat of non-petroleum silicone lubricant (item 5, appendix E) to gasket lips and outside of gasket (2).

CAUTION

Overhanging of gasket on grooved fittings may result in damage to gasket when tightening nuts. Ensure gasket does not overhang grooved fittings.

- b. Place gasket (2) over grooved fitting (3) on first component, being sure that gasket (2) does not overhang end of grooved fitting (3).
- c. Align end of second grooved fitting (6) with first grooved fitting (3). Slide gasket (2) to center position between grooves. No portion of gasket (2) should overhang grooves of grooved fittings (3 and 6).
- d. Place coupling halves (5) over gasket (2). Ensure that coupling half keys are in grooves of grooved fittings (3 and 6).
- e. Install two bolts (4). Place nuts (1) on bolts (4) and hand-tighten.

CAUTION

Over tightening nuts may cause gasket to pinch. Tighten nuts only until coupling halves are firmly together (metal-to-metal).

- f. Tighten nuts (1) alternately and equally until coupling halves (4) are firmly together.

2.3.3 Grooved-End Pipe Quick Disconnect Coupling Clamp Removal and Installation. Remove and install grooved-end pipe quick disconnect coupling clamp (Figure 2-13) as follows:

Tools

Rubber Mallet and Clamping Tool (Items 157 and 3, Appendix C)

Used To

Install 6 inch and 4 inch grooved-end pipe quick disconnect coupling clamps.

Personnel

Two required

NOTE

This is a general procedure for removal and installation of grooved-end pipe quick disconnect coupling clamps. Follow this procedure when using a grooved-end pipe quick disconnect coupling clamp to connect two TWDS components.

2.3.3.1 Removal.

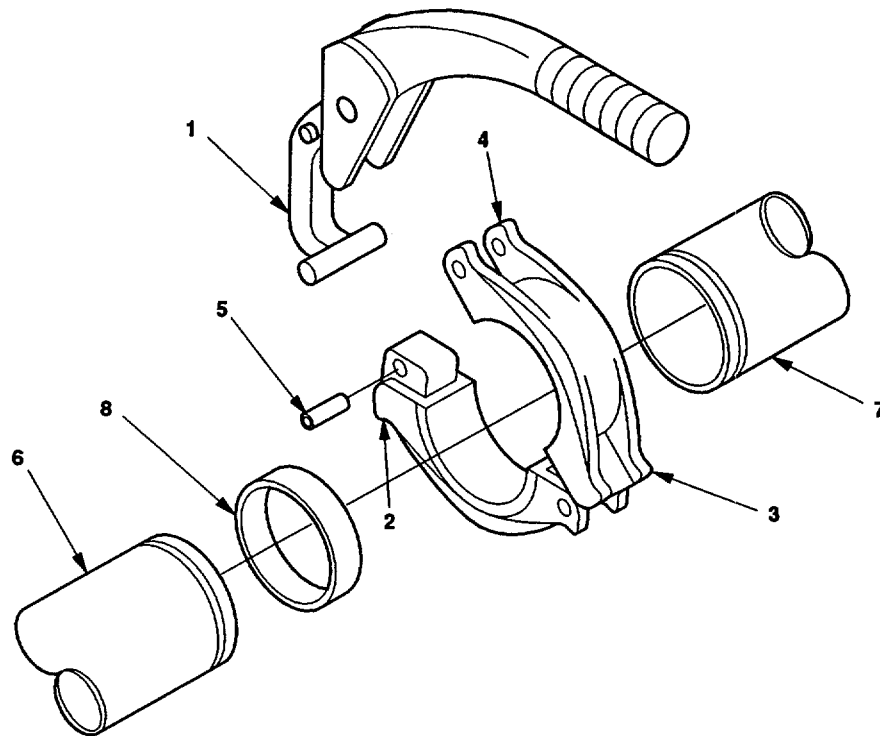


Figure 2-13. Grooved-End Pipe Quick Disconnect Coupling Clamp.

- a. Position lower portion of grooved-end pipe quick disconnect coupling clamp tool (Figure 2-13,1) under cradles (2) on lower side of grooved-end pipe quick disconnect coupling clamp (3).
- b. Position top portion of grooved-end pipe quick disconnect coupling clamp tool (1) over cradles (4) on upper side of grooved-end pipe quick disconnect coupling clamp (3).
- c. Pull handle of grooved-end pipe quick disconnect coupling clamp tool (1) over grooved-end pipe quick disconnect coupling clamp (3) and push pin (5) from grooved-end pipe quick disconnect coupling clamp (3).
- d. Remove grooved-end pipe quick disconnect coupling clamp tool (1) from grooved- end pipe quick disconnect coupling clamp (3).

- e. Open and remove grooved-end pipe quick disconnect coupling clamp (3) from grooved fittings (6 and 7).
- f. Remove gasket (8) from grooved fittings (6 and 7).
- g. Check gasket (8) for damage. If gasket (8) is damaged, replace it.

2.3.3.2 Installation.

- a. Apply thin coat of non-petroleum silicone lubricant (item 5, appendix E) to gasket lips and outside of gasket (8).

CAUTION

Overhanging of gasket on grooved fittings may result in damage to gasket when securing grooved-end pipe quick disconnect coupling clamp. Ensure gasket does not overhang grooved fittings.

- b. Place gasket (8) over grooved fitting (6) on first component, being sure that gasket (8) does not overhang end of grooved fitting (6).
- c. Align end of second grooved fitting (7) with first grooved fitting (6). Slide gasket (8) to center position between grooves. No portion of gasket (8) should overhang grooves of grooved fittings (6 and 7).
- d. Open and place grooved-end pipe quick disconnect coupling clamp (3) under gasket (8) and into grooved fittings (6 and 7). Ensure that grooved-end pipe quick disconnect coupling clamp (3) is in grooves of grooved fittings (6 and 7) and close grooved-end pipe quick disconnect coupling clamp (3) around gasket (8).
- e. Position lower portion of grooved-end pipe quick disconnect coupling clamp tool (1) under cradles (2) on lower side of grooved-end pipe quick disconnect coupling clamp (3).
- f. Position top portion of grooved-end pipe quick disconnect coupling clamp tool (1) over cradles (4) on upper side of grooved-end pipe quick disconnect coupling clamp (3).
- g. Pull handle of grooved-end pipe quick disconnect coupling clamp tool (1) over grooved-end pipe quick disconnect coupling clamp (3) and insert pin (5) into grooved-end pipe quick disconnect coupling clamp (3).
- h. Remove grooved-end pipe quick disconnect coupling clamp tool (1) from grooved-end pipe quick disconnect coupling clamp (3).

2.3.4 Lead Pumping Station Assembly. Lead pumping station assembly requires one trailer-mounted pumping assembly, and the tools, personnel, and components listed below. Remove the required components from the crates marked "PUMPING STATION" and "10- MILE SEGMENT". Perform inspections for each part for damage and operability.

2.3.4.1 Assembly Requirements.

Tools

Rubber Mallet and Clamping Tool (Items 157 and 3, Appendix C)
Pipe Wrench, 6 Inch

Used To

Install 6 inch grooved-end pipe quick disconnect coupling clamps.
Install components with threaded fittings. (Notify unit maintenance to install components with threaded fittings).

Personnel

Two required.

2.3.4 Lead Pumping Station Assembly. (Continued)

Components

Table 2-8. Components Required from Pumping Station Crate for Assembly of Lead Pumping Station.

Qty	Size	Item
2	6 inch	Butterfly Valve
1	6 inch	Check Valve
1	6 inch x 20 foot	Discharge Hose Assembly
1	6 inch	Grooved-End Pipe Quick Disconnect
		Coupling Clamp
1	6 inch	Pressure Relief Valve and Nipple

Table 2-9. Components Required from 10-Mile Segment Crate for Assembly of Lead Pumping Station.

Qty	Size	Item
1	6 inch	Coupling Half, Quick Disconnect, Female
1	6 inch	Coupling Pipe Fitting
NOTE		
Required number of suction hose assemblies depends on distance between water source and lead pumping station. Extra suction hose assemblies may be used as spares.		
12	6 inch x 10 foot	Suction Hose Assembly
1	6 inch x 4 inch x 4 inch	Y-Connection Reducer

2.3.4.2 Assembly and Installation Procedures. Reference applicable technical manual for the assembly, installation, and preparation for use of the model 600 gpm pumping assembly supplied with your TWDS.

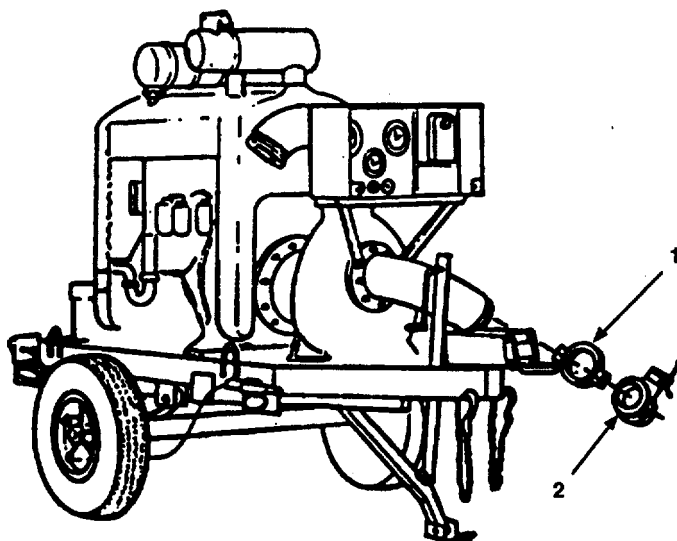


Figure 2-14. Lead Pumping Station Suction Port and Butterfly Valve Assembly. (Model 609-A shown)

- a. Ensure plastic cap has been removed from suction port (Figure 2-14, 1) on 600 gpm pumping assembly, reference applicable technical manual for suction port location on 600 gpm pumping assemblies not shown. If plastic cap has not been removed, remove cap and retain for movement or storage.
- b. Install 6 inch butterfly valve (2) on suction port (1) with grooved-end pipe quick disconnect coupling clamp (3) (para 2.3.3.2).

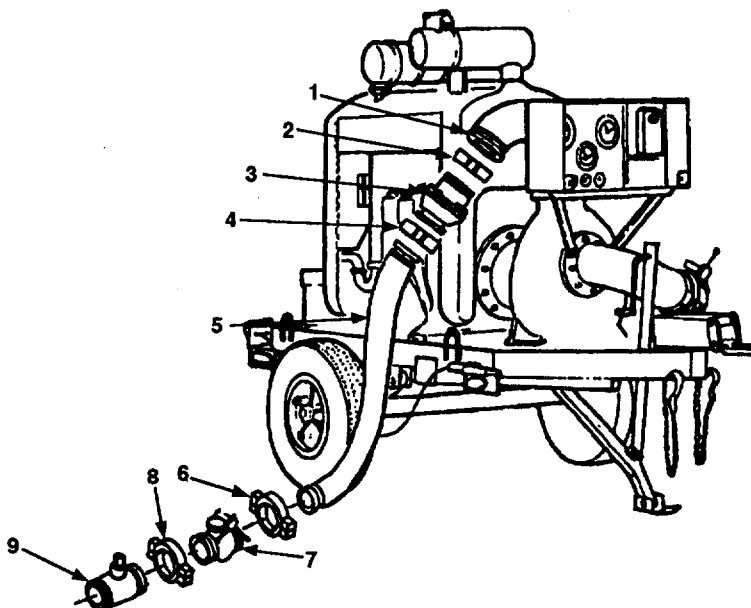


Figure 2-15. Lead Pumping Station Discharge Port and TWDS Components Assembly.

2.3.4 Lead Pumping Station Assembly. (Continued)

- c. Remove plastic cap from discharge port (Figure 2-15, 1) on 600 gpm pumping assembly, reference applicable technical manual for discharge port location on 600 gpm pumping assemblies not shown. If plastic cap has not been removed, remove it and retain for use later.

CAUTION

To prevent damage to pump, make sure arrow on check valve points away from pump.

- d. Install 6 inch check valve (3) on discharge port (1) with grooved-end pipe quick disconnect coupling clamp (2) (para 2.3.3.2). Install check valve (3) with arrow pointing away from pumping assembly (1).
- e. Install 6 inch x 20 foot discharge hose assembly (5) on end of check valve (3) with grooved-end pipe quick disconnect coupling clamp (4) (para 2.3.3.2).
- f. Install 6 inch butterfly valve (7) on end of 6 inch x 20 foot discharge hose assembly (5) with grooved-end pipe quick disconnect coupling clamp (6) (para 2.3.3.2).

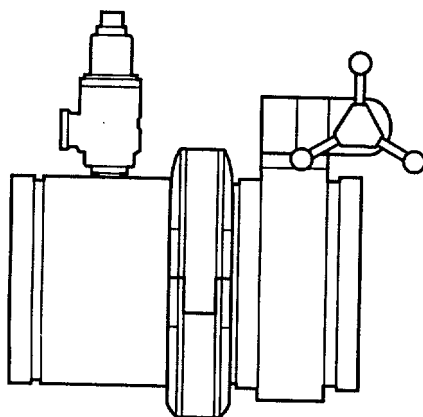


Figure 2-16. Pressure Relief Valve Installation.

WARNING

Personal injury may result from high pressure water if pressure relieve valve faces butterfly valve. Ensure pressure relief valve is installed as shown in figure 2-16 to avoid personal injury.

- g. Install 6 inch pressure relief valve (Figure 2-15, 9) on end of butterfly valve (7), as shown in figure 2-16 with grooved-end pipe quick disconnect coupling clamp (8) (para 2.3.3.2).
- h. Set butterfly valves attached to suction port (Figure 2-14, 2) and discharge hose assembly (Figure 2-15, 7) to fully open position.

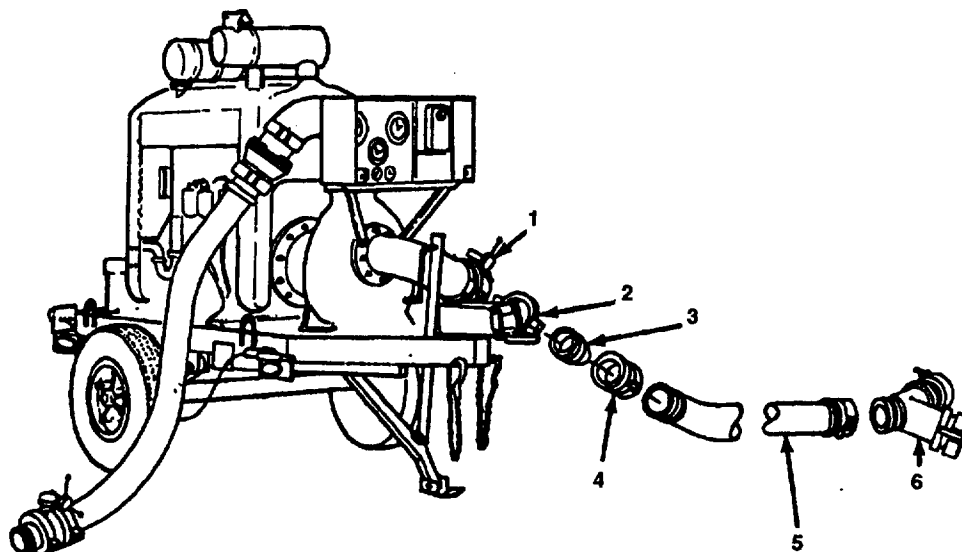


Figure 2-17. TWDS Water Source Connection Components Assembly.

NOTE

- To prevent leakage, make sure coupling pipe fitting is tightly fitted to coupling half.
 - Suction hose lengths, coupling pipe fitting, coupling half, and Y connection reducer are packed in crate marked 10-MILE SEGMENT.
 - Wrap antiseize tape in direction of threads.
- i. Wrap antiseize tape (item 9, appendix E) around threads on 6 inch coupling pipe fitting (Figure 2-17, 3). Screw 6 inch coupling pipe fitting (3) into 6 inch coupling half (4).
 - j. Install 6 inch coupling pipe fitting (3) (with attached 6 inch coupling half (4)) on end of 6 inch butterfly valve (1) on suction port of 600 gpm pumping assembly using grooved-end pipe quick disconnect coupling clamp (2), unpacked from "PUMP STATION" crate, (para 2.3.3.2).
 - k. Locate 6 inch x 10 foot lengths of rigid-walled, wire reinforced suction hose assemblies (5) with quick-disconnect fittings.
 - l. Push cam arms on 6 inch coupling half (4) forward to open position.

CAUTION

To prevent leakage, close both cam arms at the same time. Do not strike cam arms to close. Damage to couplings could result.

- m. Connect suction hose (5) to 6 inch coupling half (4). Close cam arms.
- n. Install additional 6 inch suction hose assembly lengths (5), as required, until lead pumping station can be connected to water source.
- o. Push cam arms on last suction hose (5) forward to open position.

2.3.4 Lead Pumping Station Assembly. (Continued)

CAUTION

To prevent leakage, close both cam arms at the same time. Do not strike cam arms to close. Damage to couplings could result.

- p. Connect last 6 inch suction hose assembly (5) to Y-connection reducer (6) (6 inch x 4 inch x 4 inch). Close cam arms.
- q. Connect Y-connection reducer (6) to water source. Close cam arms.

2.3.5 Boost Pumping Station Assembly. Each boost pumping station assembly requires one trailer-mounted pumping assembly, and the tools, personnel, and components listed below. Remove the required components from the "PUMPING STATION" crate. Perform inspections of each part for damage and operability.

2.3.5.1 Assembly Requirements.

Tools

Rubber Mallet and Clamping Tool (Items 157 and 3, Appendix C)

Used To

Install 6 inch grooved-end pipe quick disconnect coupling clamps.

Personnel

Two required

Components

Table 2-10. Components Required From Pumping Station Crate for Assembly of Boost Pumping Station.

Qty	Size	Item
3	6 inch	Butterfly valve
1	6 inch	Check valve
1	6 inch x 10 foot	Hose assembly
1	6 inch x 20 foot	Hose assembly
1	6 inch x 75 foot	Hose assembly
12	6 inch	Grooved-end pipe quick disconnect coupling clamp
2	6 inch	Lateral grooved pipe fitting
1	6 inch	Pressure relief valve and nipple

2.3.5.2 Assembly and Installation Procedures. Refer to applicable technical manual for assembly, installation, and preparation for use of the model 600 gpm pumping assembly supplied with your TWDS.

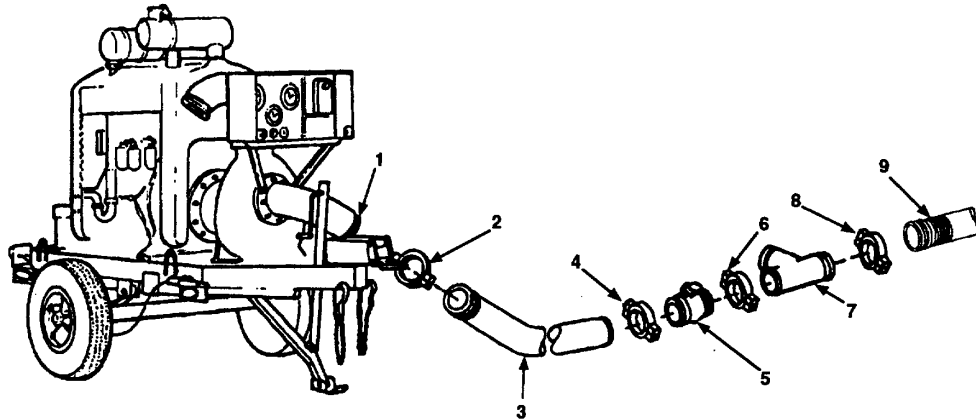


Figure 2-18. Boost Pumping Station and Suction Components Assembly.

- a. Remove plastic cap from suction port (Figure 2-18, 1) on 600 gpm pumping assembly, reference applicable technical manual for suction port location on 600 gpm pumping assemblies not shown. If plastic cap has not been removed, remove it and retain cap for movement or storage.

CAUTION

After removing components from boxes, be sure to protect them from sand and grit. Sand and grit in components may cause damage to components themselves and 600 GPM pumping assembly.

- b. Attach 6 inch x 10 foot hose assembly (3) to suction port (1) with grooved-end pipe quick disconnect coupling clamp (2) (para 2.3.3.2).
- c. Install 6 inch butterfly valve (5) on end of 6 inch x 10 foot hose assembly (3) with grooved-end pipe quick disconnect coupling clamp (4) (para 2.3.3.2).
- d. Install 6 inch lateral grooved pipe fitting (7) on end of 6 inch butterfly valve (5) with grooved-end pipe quick disconnect coupling clamp (6) (para 2.3.3.2).
- e. Install grooved-end pipe quick disconnect coupling clamp (8) on end of lateral grooved pipe fitting (7) (para 2.3.3.2) and connect 500 foot hose assembly (9).

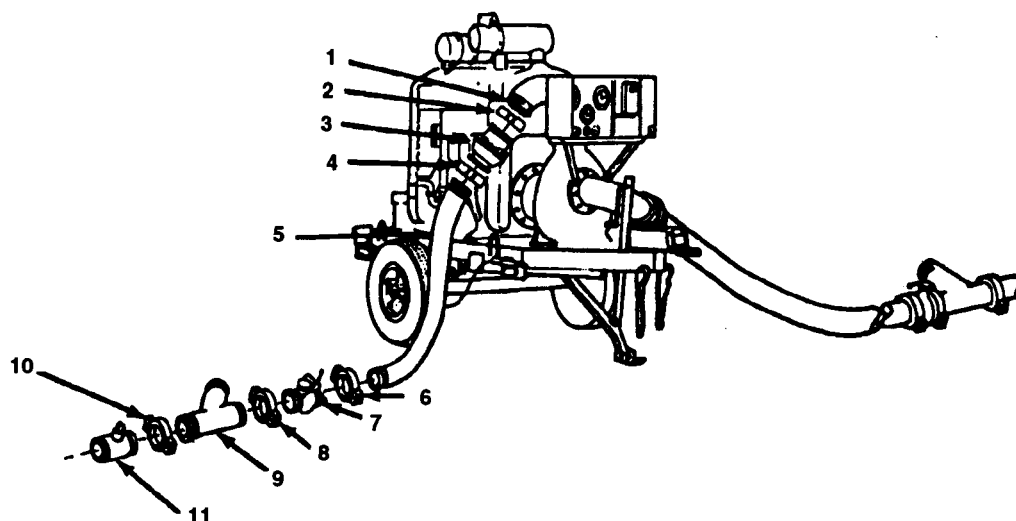
2.3.5 Boost Pumping Station Assembly. (Continued)

Figure 2-19. Boost Pumping Station and Discharge Components Assembly.

- f. Remove plastic cap from discharge port (Figure 2-19, 1) on 600 GPM pumping assembly, reference applicable technical manual for discharge port location on 600 GPM pumping assemblies not shown. If plastic cap has not been removed, remove it and retain cap for movement or storage.

CAUTION

To prevent damage to pump, make sure arrow on check valve points away from pump.

- g. Install 6 inch check valve (3) on pump discharge port (1) with grooved-end pipe quick disconnect coupling clamp (2) (para 2.3.3.2). Ensure 6 inch check valve (3) is installed with arrow pointing away from 600 gpm pumping assembly discharge port (1).
- h. Install 6 inch x 20 foot hose assembly (5) on end of 6 inch check valve (3) with grooved-end pipe quick disconnect coupling clamp (4) (para 2.3.3.2).
- i. Install 6 inch butterfly valve (7) on end of 6 inch x 20 foot hose assembly (5) with grooved-end pipe quick disconnect coupling clamp (6) (para 2.3.3.2).
- j. Install 6 inch lateral grooved pipe fitting (9) on end of 6 inch butterfly valve (7) with grooved-end pipe quick disconnect coupling clamp (8) (para 2.3.3.2).

WARNING

Personal injury may result from high pressure water if pressure relieve valve faces butterfly valve. Ensure pressure relief valve is installed as shown in figure 2-16 to avoid personal injury.

- k. Install 6 inch pressure relief valve (11) on end of lateral grooved pipe fitting (9) with grooved-end pipe quick disconnect coupling clamp (10) (para 2.3.3.2).

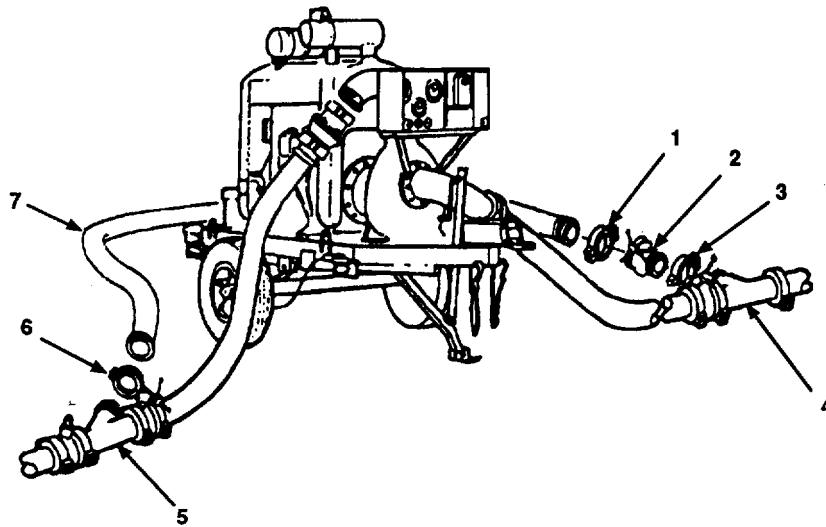


Figure 2-20. Boost Pumping Station and Bypass Components Assembly.

- l. Install 6 inch butterfly valve (Figure 2-20, 2) on end of lateral grooved pipe fitting (4) (on suction line of boost pumping station) with grooved-end pipe quick disconnect coupling clamp (3) (para 2.3.3.2).
- m. Install 6 inch x 75 foot discharge hose assembly (7) on end of 6 inch butterfly valve (2) with grooved-end pipe quick disconnect coupling clamp (1) (para 2.3.3.2).
- n. Install 6 inch x 75 foot discharge hose assembly (7) on end of lateral grooved pipe fitting (5) (on discharge line of boost pumping station) with grooved-end pipe quick disconnect coupling clamp (6) (para 2.3.3.2).

2.3.6 Assembly of Storage Assemblies. Assembly of a storage assembly requires the tools, personnel, and components listed below. Remove the required components from the "STORAGE ASSEMBLY" crate. Perform inspections of each part for damage and operability. Refer to applicable technical manual for the assembly, installation, and preparation of use for the 20,000 gallon pillow tank.

2.3.6.1 Assembly Requirements.

<u>Tools</u>	<u>Used To</u>
Rubber Mallet and Clamping Tool (Items 157 and 3, Appendix B)	Install 6 inch and 4 inch grooved-end pipe quick disconnect coupling clamps
Pipe wrench 2-7/8 inch minimum and 4 inch maximum	Install components with threaded fittings. (Notify unit maintenance to install components with threaded fittings).

Personnel
Two required

Components

Table 2-11. Components Required from Storage Assembly Crate for Assembly of Storage Assembly.

Qty	Size	Item
16	0.375 16 UNC-2A X 3.25 inches	Bolt
1	4 inch	Coupling half, female, quick disconnect
1	4 inch	Coupling half, male, quick-disconnect
1	4 inch	Coupling pipe fitting
NOTE		
Required number of discharge hose assemblies depends on distance between hoseline segment and storage assembly. Any unused hose assemblies can be used as spares.		
4	4 inch x 10 foot	Discharge hose assembly, quick disconnect
1	4 inch	Male flanged coupling half
32	0.046 ID x 0.812 OD	Flat washer
2	4 inch, Class 150	Gasket
1	4 inch	Gate valve, flanged
1	4 inch	Grooved-end pipe quick disconnect coupling clamp
16	0.375 16 UNC-2B	Hex nut
1	6 inch x 6 inch	Reducing tee

2.3.6.2 Assembly and Installation Procedures.

CAUTION

- To prevent damage to storage assembly, DO NOT choose site subject to flooding or high water.
 - To prevent damage to storage tank, DO NOT walk on tank unless you must. DO NOT drop sharp objects on tank.
 - After removing components from boxes, be sure to protect them from sand and grit.
- a. Place gasket (Figure 2-21, 14) on male flanged coupling half (18). Place 4 inch gate valve (12) on male flanged coupling half (18). Align holes of 4 inch gate valve (12), gasket (14), and male flanged coupling half (18).
 - b. Place eight flat washers (17) on eight bolts (19). Insert bolts through openings on male flanged coupling half (18), gasket (14), and 4 inch gate valve (12).

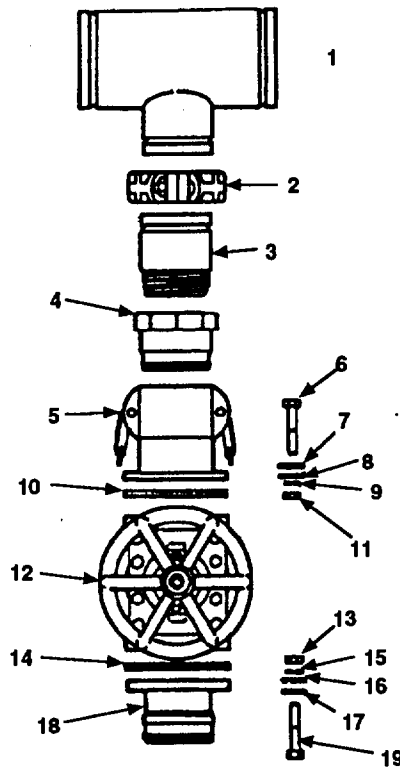


Figure 2-21. Storage Assembly Connection Components Assembly.

- c. Install eight flat washers (16), lock washers (15), and nuts (13) on eight bolts (19).
- d. Tighten nuts (13) until lock washers (15) engage and parts are firmly together.
- e. Place gasket (10) on 4 inch female coupling half (5). Place 4 inch gate valve (12) on 4 inch female coupling half (5). Align holes in 4 inch female coupling half (5), gasket (10) and 4 inch gate valve (12).
- f. Place eight flat washers (7) on eight bolts (6). Insert eight bolts (6) through openings in 4 inch female coupling half (5), gasket (10), and 4 inch gate valve (12).
- g. Place eight flat washers (8), lock washers (9), and nuts (11) on eight bolts (6).
- h. Tighten nuts (11) until lock washers (9) engage and parts are firmly together.

NOTE

Wrap anti-seize tape in direction of threads.

- i. Wrap anti-seize tape (item 9, appendix E) around threads of 4 inch coupling pipe fitting (3). Screw 4 inch coupling pipe fitting (3) into male coupling half (4).
- j. Connect 6 inch x 6 inch x 4 inch reducing tee (1) to coupling pipe fitting (3) with 4 inch grooved-end pipe quick disconnect coupling clamp (2) (para 2.3.3.2).

2.3.6 Assembly of Storage Assemblies. (Continued)

- k. Push cam arms on 4 inch female coupling half (5) (attached to gate valve) forward to open position.

CAUTION

- To prevent leakage, close both cam arms at the same time.
- Do not strike cam arms to close. Damage to couplings could result.

NOTE

When installing gate valve on reducing tee, make sure two 6 inch ends on tee are at right angles to stem on gate valve.

- l. Connect 4 inch female coupling half (5) (attached to 4 inch gate valve) to male coupling half (4). Close cam arms.
- m. Place reducing tee/gate valve assembly at point where junction with 10-mile hoseline segment is expected.

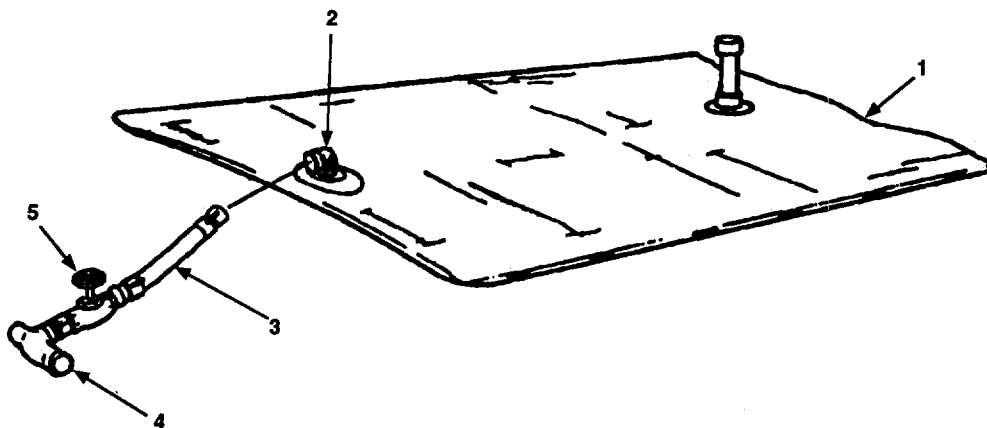


Figure 2-22. Final Assembly of Storage Assembly.

CAUTION

- To prevent leakage, close both cam arms at the same time.
 - Do not strike cam arms to close. Damage to couplings could result.
- n. Connect 4 inch x 10 foot hose assembly (Figure 2-22, 3) to female-to-female elbow (2) on 20,000 gallon pillow tank (1). Close cam arms.
- o. Connect additional 4 inch X 10 foot hose assemblies (3) as necessary to reach reducing tee/gate valve assembly.

CAUTION

- To prevent leakage, close both cam arms at the same time.
 - Do not strike cam arms to close. Damage to couplings could result.
- p. Connect female flanged coupling half (4) on the last 4 inch x 10 inch discharge hose assembly (3) with male flanged coupling half attached to 4 inch gate valve assembly (5). Close cam arms.

NOTE

Hose-laying crew should provide enough slack in hoseline to allow for connection of reducing tee/gate valve assembly.

- q. Move reducing tee/4 inch gate valve assembly (5) to a location that will be out of the way of hose-laying crews.

2.3.7 Assembly of Distribution Points. Assembly of a distribution point requires the tools, personnel, and components listed below. Remove the required components from the "DISTRIBUTION POINT" crate. Perform inspection of each part for damage and operability. Reference applicable technical manual for assembly, installation, and preparation for use of the 125 GPM pumping assembly. Reference applicable technical manuals for the assembly and preparation for use of hypochlorination unit models 1955-3 and A-506131.

2.3.7.1 Assembly Requirements.

Tools

Pipe wrench, 1 inch minimum and 2 inch maximum

Used To

Install components with threaded fittings. (Notify unit maintenance to install components with threaded fittings).

Personnel

Two required

Components

Table 2-12. Components Required from Distribution Point Crate for Assembly of Distribution Points.

Qty	Size	Item
1		Color comparator kit
2	4 inch x 2 inch	Reducer, male by female and female by male, quick disconnect
1	2 inch x 20 feet	Hose assembly
3	2 inch	Coupling half, quick disconnect, female external pipe thread
3	2 inch	Coupling half, quick disconnect, male external pipe thread
1	2 inch x 10 feet	Suction hose assembly
2	2 inch x 4 inch	Reducer, male by female and female by male, quick disconnect
1	4 inch	Coupling half, quick disconnect, female internal pipe thread
1	4 inch	Nipple
1	100 gpm	Hypochlorination Unit

2.3.7 Assembly of Distribution Points. (Continued)

Table 2-12. Components Required from Distribution Point Crate for Assembly of Distribution Points. (Continued)

Qty	Size	Item
1	4 inch	Coupling half, quick disconnect, male external pipe thread
7	2 inch x 20 feet	Hose assembly
3	2 inch x 2 inch x 2 inch	Y-connector, quick disconnect
2	1.5 inch x 2 inch	Reducer, external pipe thread, quick disconnect, female
2	2 inch	Hose swivel
2		Nozzle
2	2 inch	Dust plug
2	2 inch x 2 inch	Elbow valve
2	36 gallon	Drinking water storage bag
2		Nozzle stand assembly

2.3.7.2 Assembly and Installation.

- a. Locate male filler/discharge elbow (Figure 2-23, 1) on storage tank.

CAUTION'

After removing components from boxes, be sure to protect them from sand and grit.

- b. Push cam arms on female end of reducer (2) forward to open position.

CAUTION

- To prevent leakage, close both cam arms at the same time.
- Do not strike cam arms to close. Damage to couplings may result.

- c. Connect female end of reducer (2) to male filler/discharge elbow (1). Close cam arms.

- d. Push cam arms on rigid-walled suction hose (3) forward to open position.

CAUTION

- To prevent leakage, close both cam arms at the same time.
- Do not strike cam arms to close. Damage to couplings may result.

- e. Connect rigid-walled 2 inch X 20 foot suction hose (3) to reducer (2) attached to male filler/discharge elbow (1). Close cam arms.

- f. Locate suction port (4) and discharge port (5) on 125 GPM pumping assembly (6). Reference applicable technical manual for preparation for use of the 125 GPM pumping assembly (6).

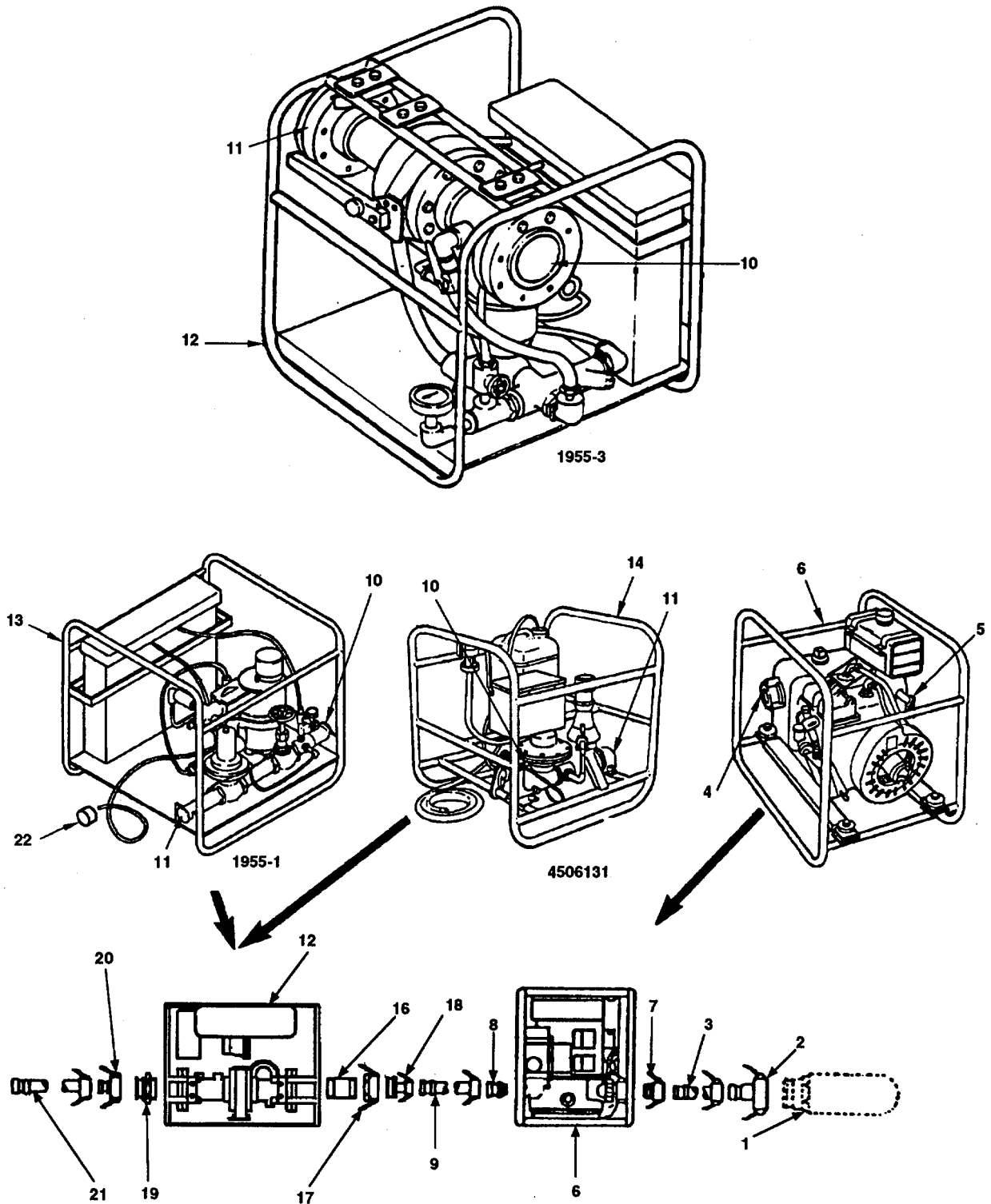


Figure 2-23. Hypochlorination Unit and 125 GPM Pump Installation.

2.3.7 Assembly of Distribution Points. (Continued)**NOTE**

Wrap antiseize tape in direction of threads.

- g. Wrap antiseize tape (item 9, appendix E) around threads on female quick disconnect coupling half (7). Screw female quick-disconnect coupling half (7) into suction port (4) of 125 GPM pumping assembly (6).
- h. Push cam arms on female quick-disconnect coupling half (7) forward to open position.

CAUTION

- To prevent leakage, close both cam arms at the same time.
 - Do not strike cam arms to close. Damage to couplings may result.
- i. Connect rigid-walled hose assembly (3) to female quick-disconnect coupling half (7) on 125 GPM pump (6). Close cam arms.

NOTE

Wrap antiseize tape in direction of threads.

- j. Wrap antiseize tape (item 9, appendix E) around threads on male quick disconnect coupling half (8). Screw male quick-disconnect coupling half (8) into discharge port (5) of 125 GPM pumping assembly (6).

CAUTION

- To prevent leakage, close both cam arms at the same time.
 - Do not strike cam arms to close. Damage to couplings may result.
- k. Connect discharge hose (9) to male quick-disconnect coupling half (8) on 125 GPM pumping assembly (6). Close cam arms.

NOTE

If installing hypochlorination unit 1955-3, refer to steps 1 through w. If installing hypochlorination units 1955-1 or A-506131 refer to steps x through ad.

- l. Locate inlet port (10) and outlet port (11) on hypochlorination unit 1955-3 (12). Refer to applicable technical manual for preparation for use of hypochlorination unit 1955-3.

NOTE

Wrap antiseize tape in direction of threads.

- m. Wrap antiseize tape (item 9, appendix E) around threads on both ends of pipe nipple (16). Screw pipe nipple (16) into hypochlorination unit 1955-3 (12).
- n. Screw female quick-disconnect coupling half (17) onto pipe nipple (16).
- o. Push cam arms on female quick-disconnect coupling half (17) forward to open position.

CAUTION

- To prevent leakage, close both cam arms at the same time.
 - Do not strike cam arms to close. Damage to couplings may result.
- p. Connect male by female reducer (18) to female quick-disconnect coupling half (17). Close cam arms.
- q. Push cam arms on male by female reducer (18) forward to open position.

CAUTION

- To prevent leakage, close both cam arms at the same time.
 - Do not strike cam arms to close. Damage to couplings may result.
- r. Connect discharge hose (9) to male by female reducer (18). Close cam arms.

NOTE

Wrap antiseize tape in direction of threads.

- s. Wrap antiseize tape (item 9, appendix E) around threads on male quick-disconnect coupling half (19). Screw male quick-disconnect coupling half (19) into outlet port (11) on hypochlorination unit 1955-3 (12).
- t. Push cam arms on reducer (20) forward to open position.

CAUTION

- To prevent leakage, close both cam arms at the same time.
 - Do not strike cam arms to close. Damage to couplings may result.
- u. Connect reducer (20) to male quick-disconnect coupling half (19) attached to hypochlorination unit 1955-3 (12). Close cam arms.
- v. Push cam arms on discharge hose (21) forward to open position.

CAUTION

- To prevent leakage, close both cam arms at the same time.
 - Do not strike cam arms to close. Damage to couplings may result.
- w. Connect discharge hose (21) to reducer (20). Close cam arms.

NOTE

Steps x through ad are for the installation of hypochlorination units 1955-1 and A-506131. Refer to applicable technical manual for preparation for use of hypochlorination unit A-506131.

- x. Unscrew two dust caps (22) from inlet port (10) and outlet port (11) of unit 1955-1 (13). Store dust caps (22) for later use.

2.3.7 Assembly of Distribution Points. (Continued)

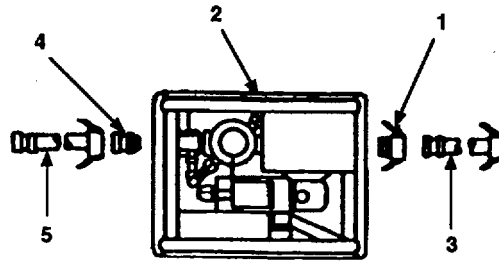


Figure 2-24. Hypochlorination Unit Model 1955-1 and Model A-506131 Installation.

NOTE

Wrap antiseize tape in direction of threads.

- y. Wrap antiseize tape (item 9, appendix E) around threads on female quick disconnect coupling half (Figure 2-24, 1). Screw female quick-disconnect coupling half (1) into inlet port (Figure 2-23, 10) on hypochlorination unit (Figure 2-24, 2).
- z. Push cam arms on female quick-disconnect coupling half (1) forward to open position.

CAUTION

- To prevent leakage, close both cam arms at the same time.
 - Do not strike cam arms to close. Damage to couplings may result.
- aa. Connect discharge hose (3) to female quick-disconnect coupling half (1) attached to hypochlorination unit (2). Close cam arms.

NOTE

Wrap antiseize tape in direction of threads.

- ab. Wrap antiseize tape (item 9, appendix E) around threads on male quick disconnect coupling half (4). Screw male quick-disconnect coupling half (4) into outlet port (Figure 2-23, 11) on hypochlorination unit (Figure 2-24, 2).
- ac. Push cam arms on discharge hose (5) forward to open position.

CAUTION

- To prevent leakage, close both cam arms at the same time.
 - Do not strike cam arms to close. Damage to couplings may result.
- ad. Connect discharge hose (5) to male quick-disconnect coupling half (4) on hypochlorination unit (2). Close cam arms.
 - ae. Push cam arms on female quick-disconnect adapter on Y-connection (Figure 2-25, 1) forward to open position.

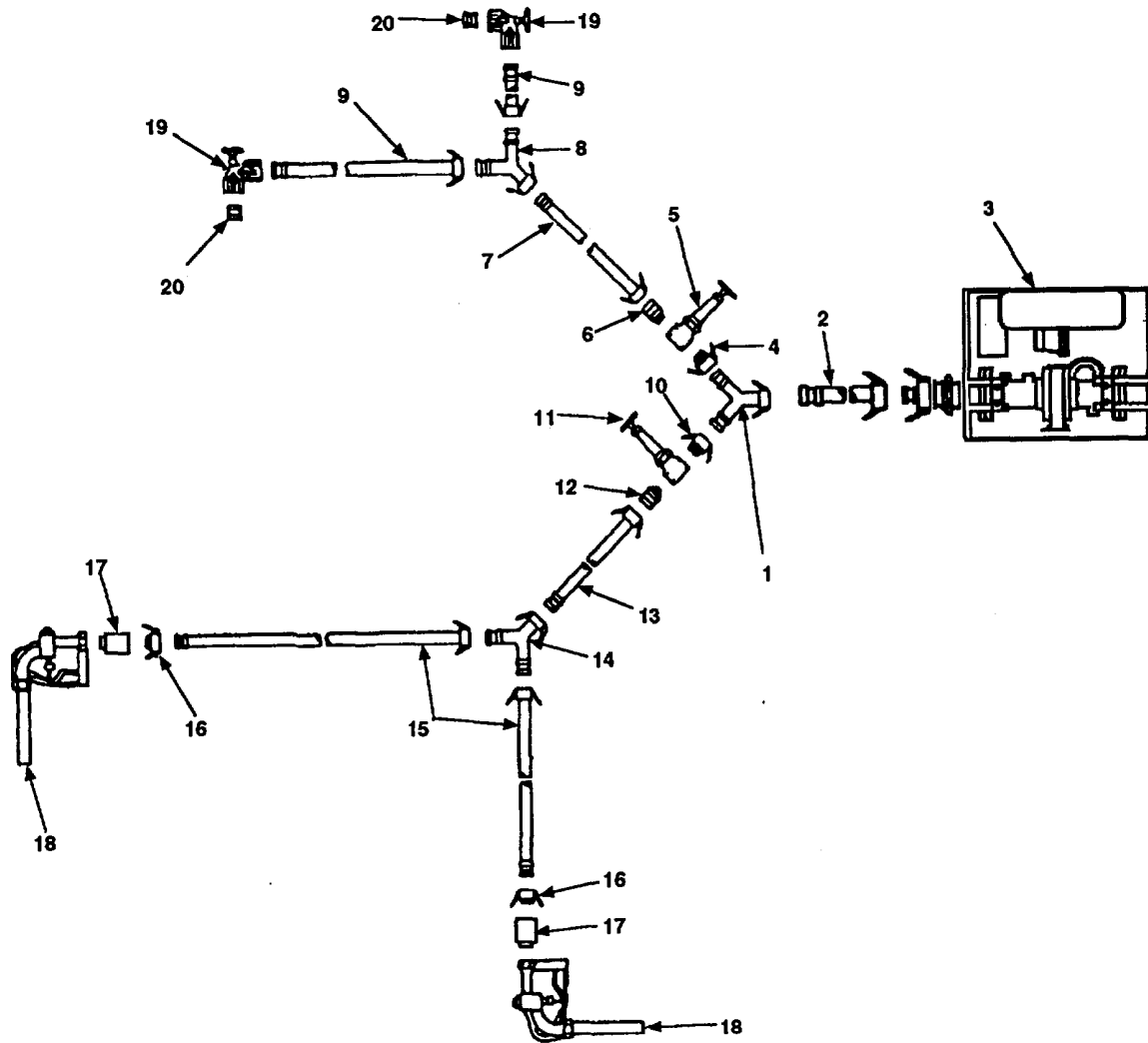


Figure 2-25. Distribution Point Assembly.

CAUTION

- To prevent leakage, close both cam arms at the same time.
- Do not strike cam arms to close. Damage to couplings may result.

af. Connect female adapter on Y-connection (1) to discharge hose (2) attached to hypochlorination unit (3). Close cam arms.

NOTE

Wrap antiseize tape in direction of threads.

ag. Wrap antiseize tape (item 9, appendix E) around threads of female quick- disconnect coupling half (4) and screw female quick-disconnect coupling half (4) into one end of 2 inch gate valve (5).

2.3.7 Assembly of Distribution Points . (Continued)

NOTE

Wrap antiseize tape in direction of threads.

- ah. Wrap antiseize tape (item 9, appendix E) around threads of male quick disconnect coupling half (6) and screw male quick-disconnect coupling half (6) into end of 2 inch gate valve (5).
- ai. Push cam arms on female quick-disconnect coupling half (4) forward to open position.

CAUTION

- To prevent leakage, close both cam arms at the same time.
 - Do not strike cam arms to close. Damage to couplings may result.
- aj. Connect female quick-disconnect coupling half (4) on 2 inch gate valve (5) to male adapter on Y-connection (1). Close cam arms.
 - ak. Push cam arms on discharge hose (7) forward to open position.

CAUTION

- To prevent leakage, close both cam arms at the same time.
 - Do not strike cam arms to close. Damage to couplings may result.
- al. Connect discharge hose (7) to male quick-disconnect coupling half (6) on 2 inch gate valve (5). Close cam arms.
 - am. Push cam arms on Y-connection (8) forward to open position.

CAUTION

- To prevent leakage, close both cam arms at the same time.
 - Do not strike cam arms to close. Damage to couplings may result.
- an. Connect female adapter on Y-connection (8) to discharge hose (7). Close cam arms.
 - ao. Push cam arms on two discharge hoses (9) forward to open position.

CAUTION

- To prevent leakage, close both cam arms at the same time.
 - Do not strike cam arms to close. Damage to couplings may result.
- ap. Connect two discharge hoses (9) to male adapters on Y-connection (8). Close cam arms.
 - aq. Repeat steps ag through ap to connect female quick-disconnect coupling half (10), 2 inch gate valve (11), male quick-disconnect coupling half (12), discharge hose (13), Y-connection (14), and discharge hoses (15).

NOTE

- If tank trucks are to be filled, install reducers, to match truck fitting, on discharge hoses (9 or 15).
 - When reducers are installed on hose ends, water flow is controlled by 2 inch gate valves (5 or 11).
 - Wrap antiseize tape in direction of threads.
- ar. Wrap antiseize tape (item 9, appendix E) around threads on two reducers (16). Screw reducers (16) into two hose swivels (17).

NOTE

Wrap antiseize tape in direction of threads.

- as. Wrap antiseize tape (item 9, appendix E) around threads of two hose swivels (17). Screw two hose swivels (17) into two nozzles (18).
- at. Push cam arms on two reducers (16) forward to open position.

CAUTION

- To prevent leakage, close both cam arms at the same time.
 - Do not strike cam arms to close. Damage to couplings may result.
- au. Connect two reducers (16) to two discharge hoses (15). Close cam arms.
- av. Push cam arms on ends of two elbow valves (19) forward to open position.

CAUTION

- To prevent leakage, close both cam arms at the same time.
 - Do not strike cam arms to close. Damage to couplings may result.
- aw. Connect two elbow valves (19) to two discharge hoses (9). Close cam arms.
- ax. Push cam arms on open ends of two elbow valves (19) forward to open position.

CAUTION

- To prevent leakage, close both cam arms at the same time.
 - Do not strike cam arms to close. Damage to couplings may result.
- ay. Connect two dust plugs (20) to two elbow valves (19). Close cam arms.

2.3.7 Assembly of Distribution Points. (Continued)

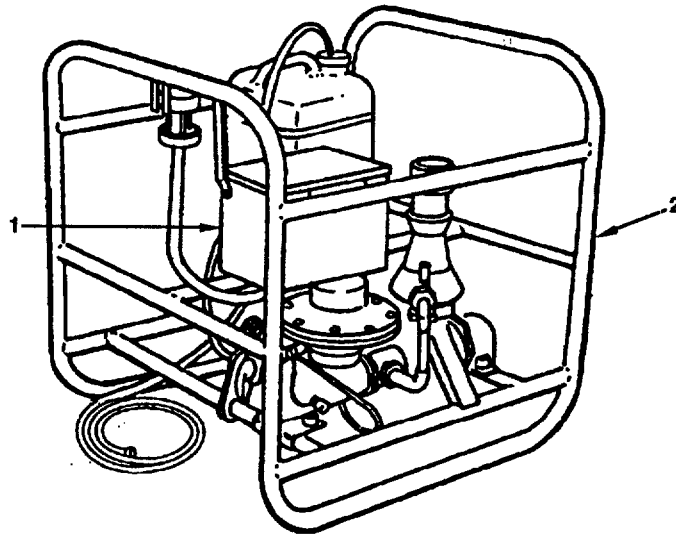


Figure 2-26. Hypochlorination Unit.

az. Store color comparator kit in metal box (Figure 2-26, 1) mounted on skid of hypochlorination unit (2).

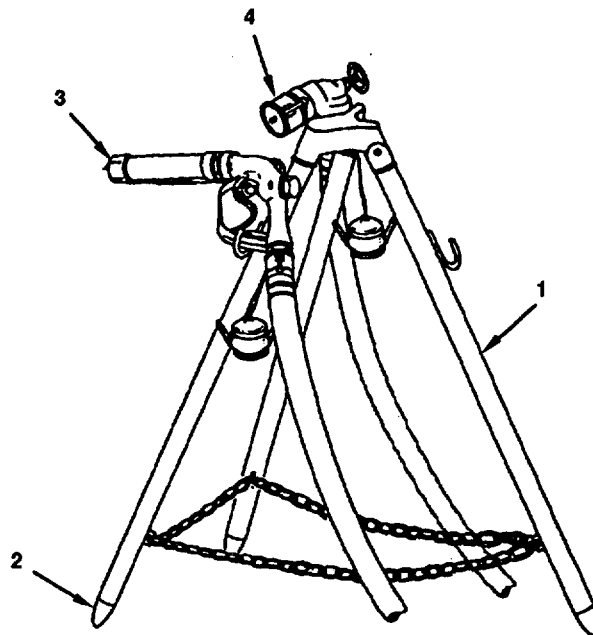


Figure 2-27. Tripod Stand Assembly.

ba. Install two nozzle stand assemblies (Figure 2-27, 1). Spread three tripod legs (2) and secure legs with rocks or embed pointed ends in ground. Locate nozzle stand assemblies (1) at convenient spots for hanging distribution point nozzles (3) and elbow valves (4).

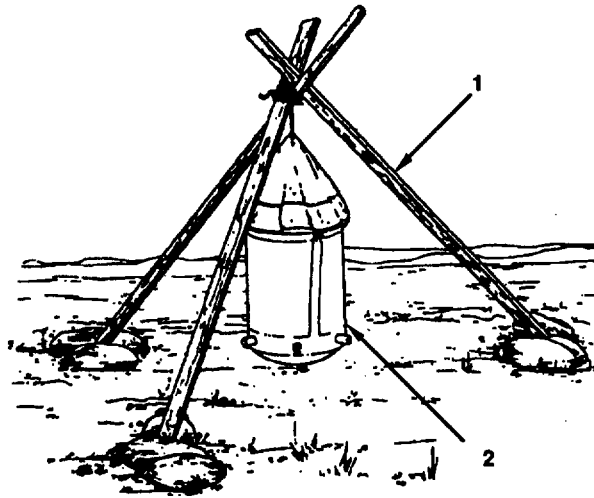


Figure 2-28. Tripod and Water Storage Drinking Bag.

WARNING

Tripods must be at least 6 feet tall and capable of supporting 400 pounds. Personal or personnel injury may result if tripods are not built to correct height or cannot support 400 pounds.

- bb. Using locally available materials, construct tripod supports (Figure 2-28, 1) on which to hang drinking water storage bag (2). Hang drinking water storage bag (2) on tripod (1).

2.3.8 Assembly of 10-Mile Hoseline Segment.

2.3.8.1 Requirements. Assembly of 10-mile hoseline segment requires the tools, personnel, and components listed in paragraph 2.3.8.2. Remove the required components from the "10-MILE SEGMENT" crate. Perform inspection of each part for damage and operability.

2.3.8.2 General Information. This paragraph provides general instructions for assembly of the 10-mile hoseline segment.

NOTE

Newer model flaking boxes contain two 500 foot hose assemblies. If newer model flaking boxes are used there will be a total of 54 flaking boxes supplied with a TWDS.

2.3.8.2.1 Hoseline is packed in 33 crates. Each crate contains four flaking boxes. Each flaking box contains one 500 foot length of hoseline. Installation of 10-mile segment will require at least 27 crates, 108 flaking boxes of hoseline. Use enough hoseline to provide approximately three feet of slack so that connections to pumping stations and storage assemblies are easily made.

2.3.8.2.2 Hoseline is installed by flaking hose from rear of truck and manually positioning hose. The lengths of hose are connected together using 6 inch grooved pipe couplings. Every 1,000 feet, a swivel joint is installed to eliminate twisting and possible damage to the equipment during hoseline packing.

2.3.8 Assembly of 10-Mile Hoseline Segment. (Continued)

CAUTION

Minimum capacity of truck should be no less than 2-1/2 tons. Damage may result to trucks that do not have the minimum load capacity.

2.3.8.2.3 A maximum of four flaking boxes are loaded onto a 2-1/2 ton cargo truck. Some TWDS may contain flaking boxes which can be lifted only from the sides and cannot be approached from tailgate end. If truck used does not have removable side walls or stakes, the bottom flaking box must have forklift openings at tailgate end, or be loaded by lifting sling.

CAUTION

- Hose lengths should be snaked slightly to allow at least 3 feet of slack for each hoseline length.
- Contraction of taut hoseline during startup will damage equipment.
- Ensure bends, twists, or kinks in hoseline are removed when hose is flaked. Failure to remove bends, twists, or kinks may result in damaged equipment.

2.3.8.2.4 As truck moves forward along route, hose flakes out of boxes and is manually laid out behind the truck. Any bends, twists, or kinks in hoseline must be straightened.

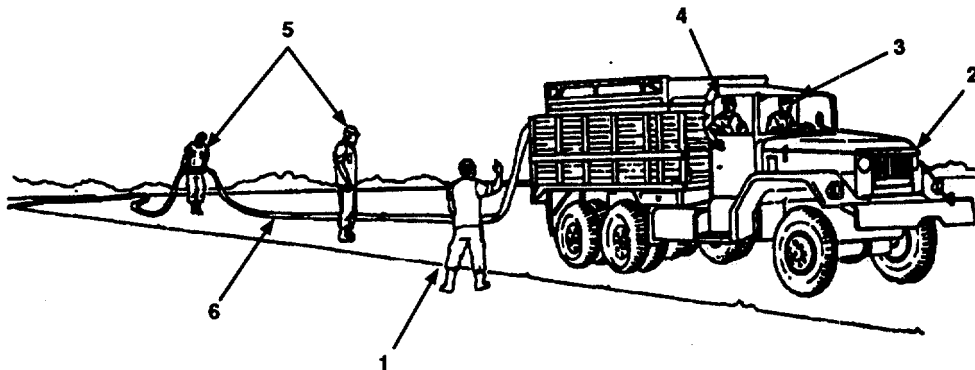


Figure 2-29. 10-Mile Hoseline Segment Installation.

2.3.8.2.5 A minimum of two trucks with crews of five men each is recommended for hose-laying operations. Crews alternate between laying hose and reloading trucks. Individual task assignments for each crew member are as follows:

- Supervisor (Figure 2-29, 1): One supervisor (1) is needed per truck (2) to oversee hose-laying operations. Should a problem develop during hose-laying operations, the supervisor (1) is responsible for contacting operators at pumping stations who are packing the hoseline.
- Driver (3): One driver (3) is needed to operate each truck (2).
- Assistant Driver (4): An assistant driver (4) is needed to observe hose-laying operation, tell driver (3) to speed up, slow down, or stop truck (2) depending on needs of the line walkers (5) who are straightening and

repositioning hoseline (6). He must also observe hose for catching or binding as it flakes out of box.

- d. Linewalkers (5): A minimum of two linewalkers (5) are needed to follow behind each truck (2) and perform the following tasks:
 - (1) Straighten out kinks or bends in hoseline.
 - (2) Remove small obstructions, branches, and sharp rocks which can damage hoseline.
 - (3) Check that swivel joint is installed at every 1,000 foot connection.

2.3.8.2.6 Empty hose is easily blown by strong winds, causing damage to installations and equipment. To avoid high wind problems, pack newly-laid hose as soon as possible. Once lead pump and first boost pump are connected by hoseline, reference applicable technical manual for pump operating procedures and packing hoseline.

2.3.8.2.7 During hose-laying operations, it is essential that operators at pumping stations and storage assemblies communicate with each other and with hose-laying crews. If a problem develops with the hose-laying operation, immediately notify operators who are packing hoseline. If a problem occurs when hoseline is packed, immediately notify hose-laying supervisor and other operators.

2.3.8.3 Assembly Requirements.

- a. Assembly of the 10-mile hoseline segment requires the equipment and personnel outlined in paragraphs 2.3.8.1 and 2.3.8.2. These requirements generally remain the same in each situation. However, the number of components required for assembly will vary depending on the route and terrain being crossed, as well as TWDS assigned mission.
- b. Hoseline is packed in 33 crates marked "HOSE ASSEMBLY, 6 INCH, 500 FEET". Each crate contains either two or four flaking boxes; each flaking box contains either one or two 500 foot hose assemblies, respectively. Installation of a full 10-mile segment, along a direct route across even terrain, will require at least 108 (54 if newer model flaking box) flaking boxes of hoseline (para 2.3.8.2.1).
- c. One 6 inch grooved pipe coupling is required for each 500 foot hoseline assembly used. One swivel point is required for every 1,000 feet of hoseline. For example, if 108 flaking boxes of hoseline are used, then 108 grooved pipe couplings and 54 swivel joints are required for installation (para 2.3.8.5). If the newer style flaking boxes are used then only 54 grooved pipe couplings are required and swivel joints are required.
- d. Road crossing guards and suspension kits are used when the hoseline crosses roads or obstacles in the terrain (such as streams, rivers, gullies, and ravines). Each road crossing guard is 5 feet in length. If the width of a road being crossed is 15 feet, for example, then three or four road crossing guards are required to protect the hoseline (para 2.3.8.6). Each suspension kit contains enough wire rope to construct a span of 200 feet. Therefore, one suspension kit is required to cross a 150 foot wide gap; or one suspension kit can be used to construct spans across two 75 foot wide gaps (para 2.3.8.7).
- e. The pressure-reducing valve assembly is required when pressure at a certain point in the hoseline is expected to exceed 225 psi. If the hoseline crosses over a steep hill or ridge, then a pressure-reducing valve may be required on the "downhill" side of the hoseline route (para 2.3.1.9).
- f. Other components contained in the "10-MILE HOSELINE SEGMENT" crate are used for various purposes. The lifting sling is used when a forklift is not available to load flaking boxes onto trucks (para 2.3.8.2.3.). The end cap is used when dead-end service is required (end of hoseline route does not connect to a storage and/or distribution assembly). The repair kit is used to repair damaged hoseline. The displacement and evacuation kit along with the packing kits are used to recover and pack hoseline in flaking boxes.

2.3.8 Assembly of 10-Mile Hoseline Segment. (Continued)

g. Listed below are the total number, size, and type of components packed in the "10-MILE HOSELINE SEGMENT" crate. Remove the components needed to complete the assigned mission. Perform inspection of each part for damage and operability.

Table 2-13. Components Required from 10-Mile Segment Crate for Assembly of 10-Mile Hoseline Segment.

Qty	Size	Item
1		Displacement and evacuation kit
1	6 inch	End cap
15	6 inch	Grooved pipe coupling
1		Lifting sling
1		Packing kit
1		Pressure-reducing valve, skid mounted
1	6 inch	Pressure relief valve and nipple
1		Repair Kit
24	5 foot	Road crossing guard
4	1-1/4 inch	Socket wrench
4		Socket wrench handle
5		Suspension kit
65	6 inch	Swivel joint and coupling

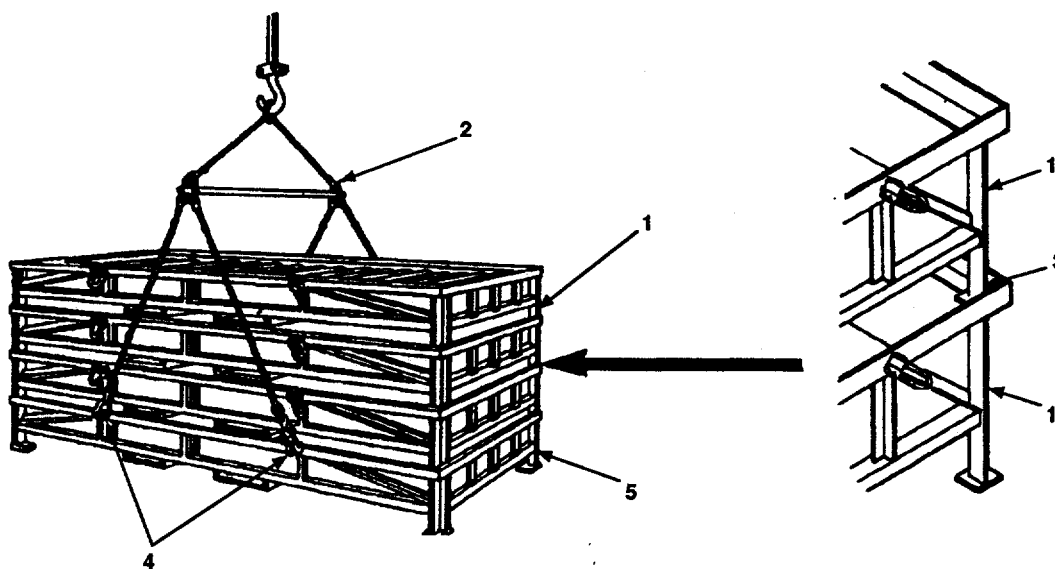


Figure 2-30. Loading and Securing Flaking Boxes.

2.3.8.4 Preparation for Hose Laying. To prepare for hose laying, flaking boxes (Figure 2-30, 1) are first loaded on truck. A forklift or crane with lifting sling (2) is used for loading. Remove flaking boxes (1) from crate and proceed as follows:

- a. Make sure each flaking box (1) is properly aligned and nested in top angle (3) of flaking box (1) below.

WARNING

- Make sure crane or forklift has minimum lifting capacity of 6,000 pounds.
- DO NOT stand under load being lifted as death or serious injury may result.

NOTE

- If using lifting sling (2), attach hooks to lifting clevises (4) on bottom flaking box (5).
 - Ensure open ends of hooks face outward.
 - Ensure tailgate assemblies of flaking boxes face rear of truck.
- b. Using crane or forklift with 6,000 pound lifting capacity, lift and stack flaking boxes on truck bed. DO NOT load or stack more than four flaking boxes on one truck at a time. Position flaking boxes on truck bed with tailgate assemblies facing to rear.
- c. If truck does not have side walls, use lifting devises (4) as attachment points and securely tie boxes to truck.

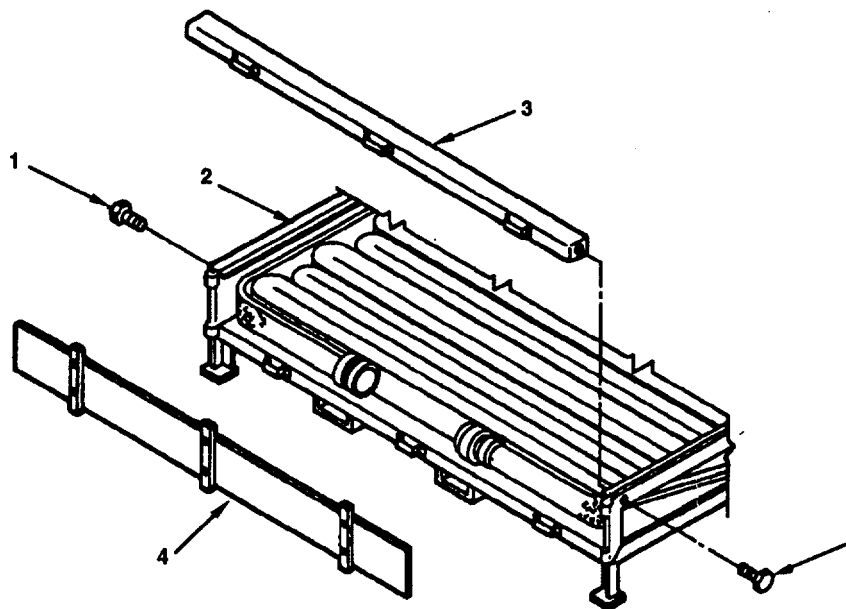


Figure 2-31. Tailgate Assembly Removal.

- d. Remove two screws (Figure 2-31, 1) on rear of bottom flaking box (2) that secure tie bar (3) to flaking box (2).
- e. Lift and remove tie bar (3) from flaking box (2).
- f. Lift and remove tailgate assembly (4).
- g. Install tie bar (3) on flaking box (2).

2.3.8 Assembly of 10-Mile Hoseline Segment . (Continued)

- h. Install two screws (1). Tighten screws (1) until tie bar (3) is firmly secured to flaking box (2).
- i. Repeat steps c through h for other three flaking boxes.

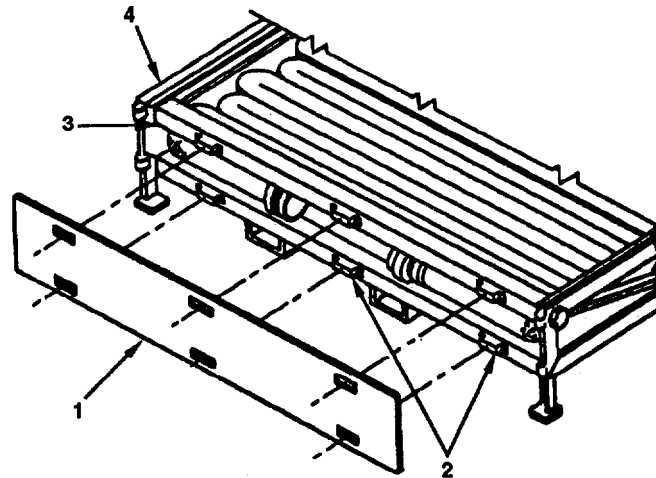


Figure 2-32. Positioning Breakaway on Flaking Box Assembly.

NOTE

- Do not secure breakaways too tightly.
 - Breakaways must fall away automatically during hose-laying operation.
 - Recover and retain breakaways for reuse.
- j. Position breakaway (Figure 2-32, 1) so that holes in breakaway (1) are aligned with cleats (2) on tie bar (3) and flaking box (4).
 - k. Leave both ends of hose (Figure 2-33, 1) outside openings on either side of breakaway (2).
 - l. Locate three lengths of wire (3) provided with breakaway (2).
 - m. Wrap end of one wire (3) around tie bar (4) at point where one of cleats (5) is welded to tie bar (4). Wire (3) should not pass over outside of cleat (5).
 - n. Loop wire (3) through notch (6) in cleat (5) as shown.
 - o. Bring wire (3) over outside of breakaway (2) and back through notch (6) in cleat (5) on bottom of flaking box (7).
 - p. Leave bottom end of wire hanging.
 - q. Repeat steps 1 through o to attach two remaining lengths of wire (3) to other cleats (5) on tie bar (4) and flaking box (7).

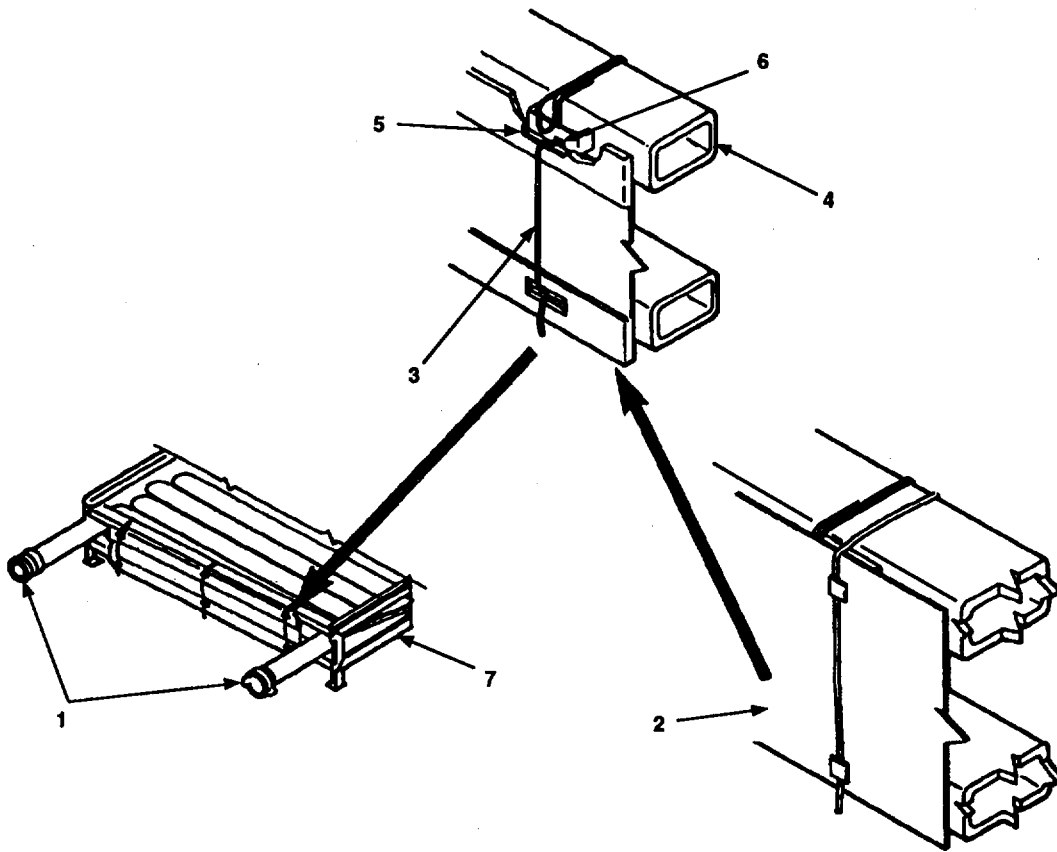


Figure 2-33. Breakaway Installation.

- r. Repeat steps 1 through q for other three flaking boxes.

2.3.8.5 Hose Laying and Installation.

CAUTION

After removing components from boxes, be sure to protect them from sand and grit.

NOTE

Remove caps or packaging material from ends of hose.

- a. Remove 6 inch grooved pipe coupling (para 2.3.2.1) from leading ends of hose assemblies in flaking boxes (Figure 2-34, 1, 2, 3, and 4).

CAUTION

After removing components from boxes, be sure to protect them from sand and grit.

- b. Connect leading end of hose in flaking box four (figure 2-34, 4) to trailing end of hose in flaking box three (3) with 6 inch grooved pipe coupling (para 2.3.2.2).

2.3.8 Assembly of 10-Mile Hoseline Segment. (Continued)

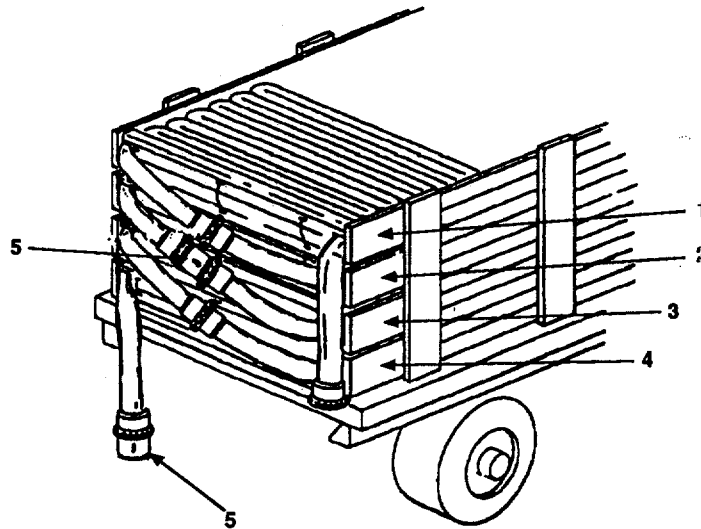


Figure 2-34. Grooved Pipe Coupling and Swivel Joint installation.

CAUTION

Install swivel joint after every 1,000 feet of hoseline, 2 hoseline segments. Failure to install swivel joint every 1,000 feet may result in damage to equipment.

NOTE

Newer flaking boxes contain 1,000 foot sections of hose.

- c. Connect swivel joint (5) to leading end of hose in flaking box three (3) with 6 inch grooved pipe coupling (para 2.3.2.2).
- d. Connect trailing end of hose in flaking box two (2) to swivel joint (5) with grooved-end pipe quick disconnect coupling (para 2.3.3.2).
- e. Connect leading end of hose in flaking box two (2) to trailing end of hose in flaking box one (1) with 6 inch grooved pipe coupling (para 2.3.2.2)

CAUTION

Install swivel joint after every 1,000 feet of hoseline, 2 hoseline segments. Failure to install swivel joint every 1,000 feet may result in damage to equipment.

- f. Connect swivel joint (5) to trailing end of hose in flaking box four (4) with 6 inch grooved pipe coupling (para 2.3.2.2).
- g. Connect leading end of hose assembly (Figure 2-35, 1) in flaking box one (Figure 2-34, 1) to pressure relief valve (Figure 2-35, 2) on discharge hose (3) at lead pumping station (4). Attach leading end of hose (1) with grooved- end pipe quick disconnect coupling clamp (5) (para 2.3.3.2).

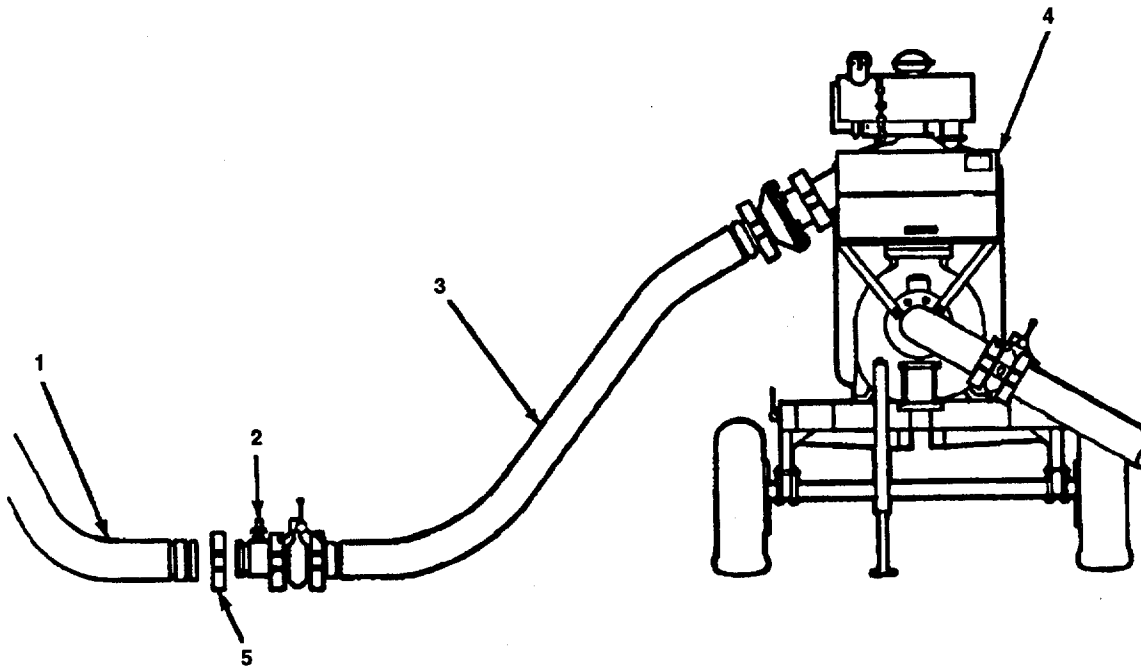


Figure 2-35. Connection to Lead Pumping Station.

CAUTION

DO NOT leave hose on roadway or track that will be used by other vehicles. Hoseline is easily damaged by rough handling or abrasive contact with rocks.

NOTE

- Restrain hose assembly manually until first 50 feet of hose assembly is in position.
- After 50 feet of hose assembly is in position, the weight of the hose will hold line in place.

h. Refer to paragraphs 2.3.8.2.4 through 2.3.8.2.7 and deploy hose assembly.

i. Continue to lay hose until hoseline in all four boxes has been flaked.

CAUTION

Swivel joints (Figure 2-36, 1) must be installed at every 1,000 feet in hoseline (2). If not installed, hoseline (2) will twist during startup and cause damage to equipment.

j. Repeat steps a through i (leaving out step g) to connect each truckload of hoseline to sections already laid. Be sure to install swivel joints (Figure 2-36, 1) at every 1,000 feet in hoseline (2).

k. Connect hoseline (2) to each boost pumping station and storage assembly as those installation sites are reached.

2.3.8 Assembly of 10-Mile Hoseline Segment. (Continued)

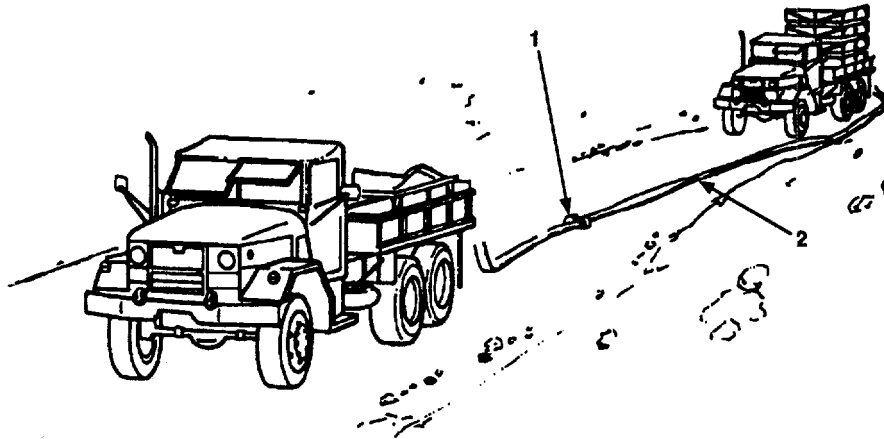


Figure 2-36. Swivel Joint Connection.

1. Retain empty flaking boxes, tailgates, and breakaways for reuse.

2.3.8.6 Installation of Road Crossing Guard.

- a. Dig trench (Figure 2-37, 1) 18 inches deep across road.
- b. Engineering support is required if hoseline (2) is being run beneath a railroad bed.
- c. Lay hoseline (2) in trench (1).
- d. Position roadway crossing guards (3) over hoseline (2) at appropriate intervals. Nail guards (3) to planks (4) if planks (4) are used.

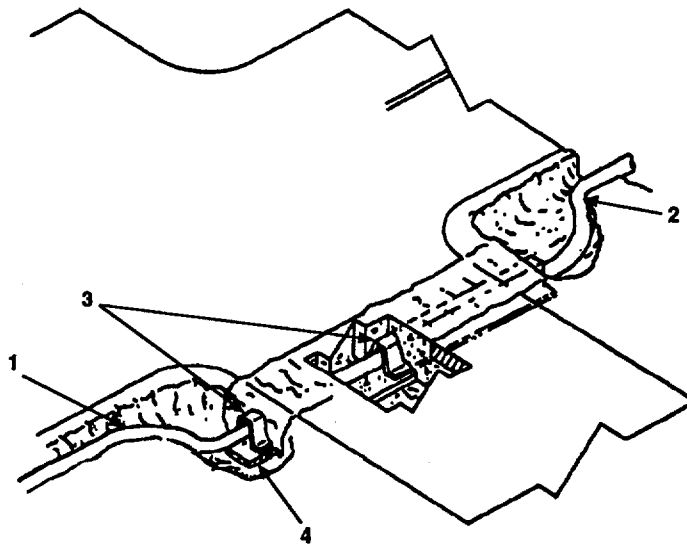


Figure 2-37. Road Crossing Guard Installation.

- e. Backfill trench (1) using dirt removed from step a. Fill trench (1) to a level 1 to 2 inches above original roadbed before packing earth down. Ensure dirt is securely packed around sides of railroad crossing guard.

2.3.8.7 Assembly and Installation of Suspension Devices .

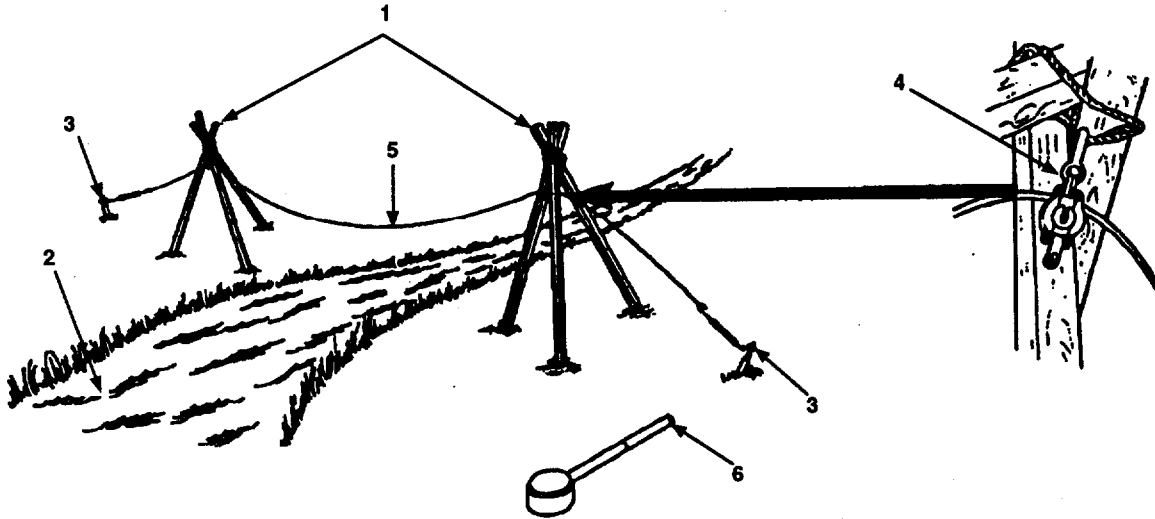


Figure 2-38. Tripods and Wire Rope Installation.

- a. Using available materials, construct a tripod (Figure 2-38, 1) on either side of stream (2), gap, or other obstruction to be spanned. Tripods (1) should be strong enough and high enough to support hoseline. Use manila rope to cross gully.

NOTE

Depending on the type of suspension kit issued with the equipment, anchor stakes will either be angled or round.

- b. Using driving head (6), drive an anchor stake (3) into ground at a 30 degree angle approximately 15 feet from each tower. Anchor stakes (3) should be in line with tripods (1) and extend approximately 6 inches above ground.
- c. Hang a pulley block (4) from each tripod (1) and thread wire rope (5) through pulley (4) on near side. Tie manila rope to wire rope (5).
- d. Pull wire rope (5) across stream (2) or obstruction by manila rope.
- e. When wire rope (5) reaches far side of stream (2) or obstruction, remove manila rope from wire rope (5).
- f. Thread wire rope (5) through pulley block (4) on far side of stream (2) or obstruction.
- g. Construct loop of wire rope (Figure 2-39, 1) about 9 inches from one end of wire rope (2) and insert thimble (3) into loop.
- h. Locate two clamp assemblies (4, 5, and 6). Remove two nuts (4) and one clamp (5) from each U-bolt (6).

2.3.8 Assembly of 10-Mile Hoseline Segment. (Continued)

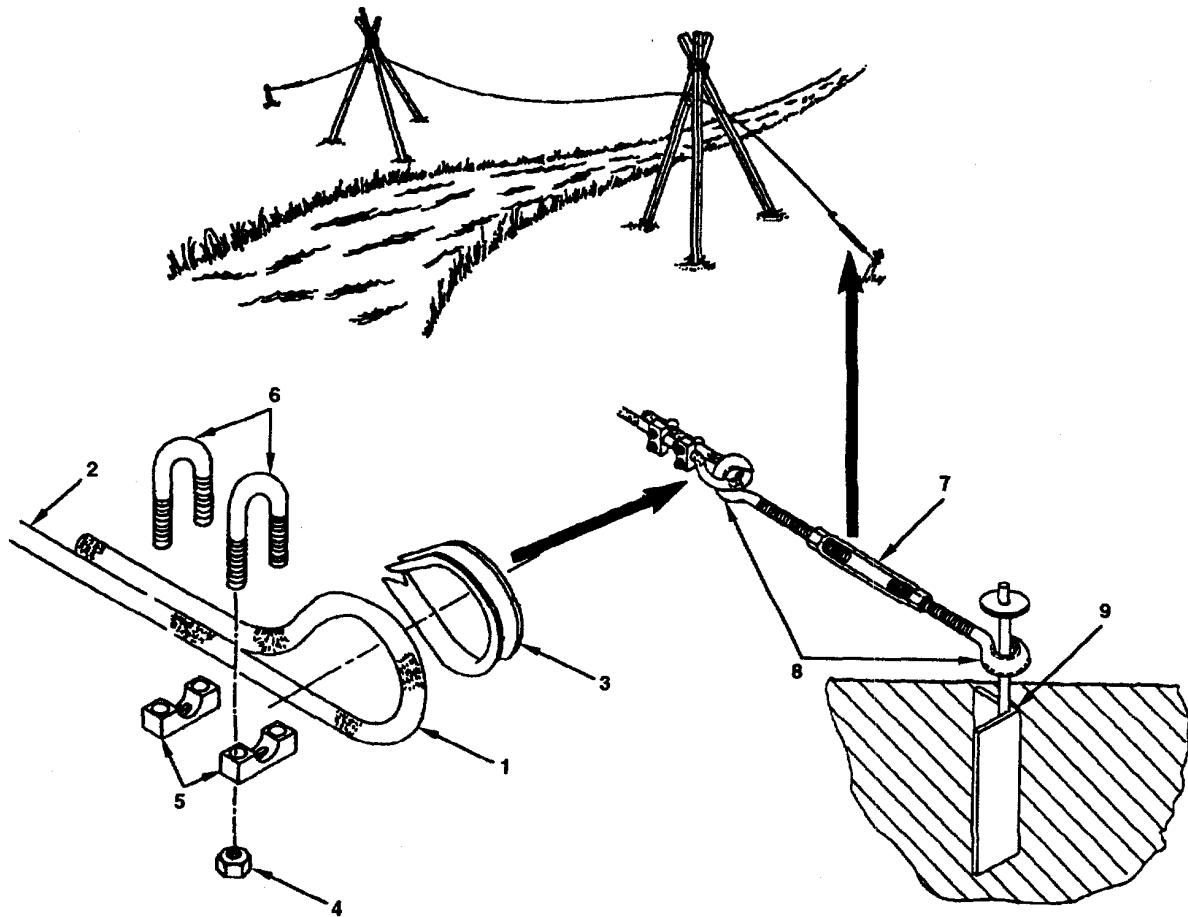


Figure 2-39. Securing Wire Rope.

NOTE

Assemble as shown in Figure 2-36.

- i. Place one U-bolt (6) over double portion of wire rope (2) approximately 2 inches from end of wire rope thimble (3).
- j. Install clamp (5) and two nuts (4). Tighten nuts (4) until double portion of wire rope (2) is held firmly together.
- k. Place second U-bolt (6) over double portion of wire rope (2), approximately 4 inches down from first clamp.
- l. Install clamp (5) and two nuts (4). Tighten nuts (4) until doubled portion of wire rope (2) is held snugly together.
- m. Install thimble (3). Tap U-bolt assembly towards thimble (3) until thimble (3) is secure. Tighten nuts (4) on U-bolts (6).
- n. Unscrew turnbuckle hook (8) until it is almost fully extended. This will allow for adjustment to take up wire rope (2) slack.
- o. Attach one turnbuckle hook (8) to loop in wire rope (2). Attach other turnbuckle hook (8) to anchor stake (9).

- p. Repeat steps f through m with opposite end of wire rope (2).
- q. Using turnbuckles (7), adjust slack in wire rope (with no load) until wire rope (2) is taut.

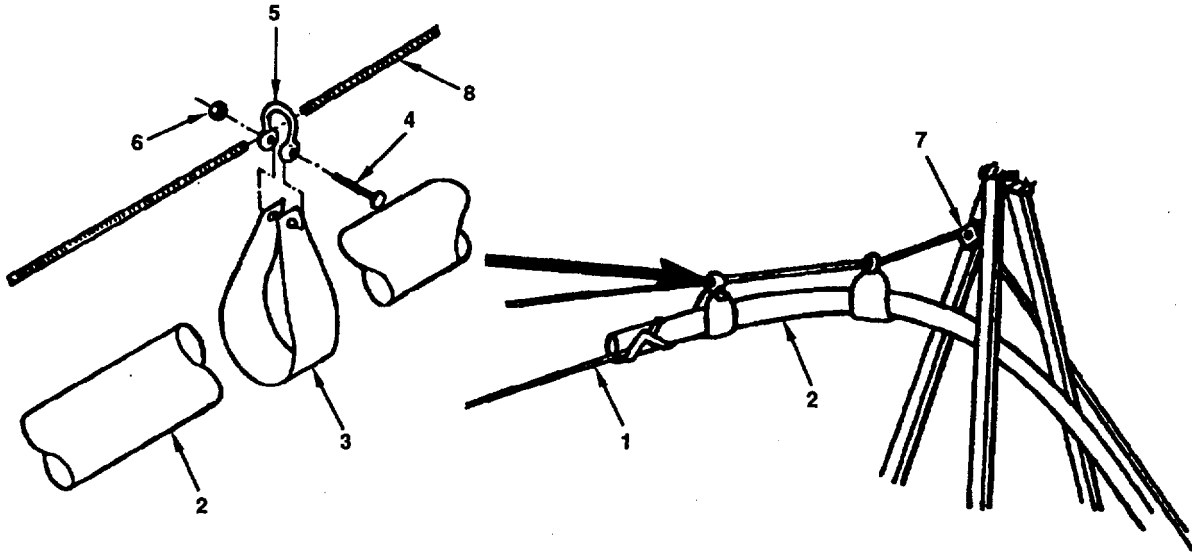


Figure 2-40. Saddle Installation.

- r. Tie manila rope (Figure 2-40, 1) to leading end of hoseline (2). Make sure manila rope (1) is long enough to cross span.

NOTE

As each saddle assembly is disassembled, inspect saddle for tears and damaged or missing metal eyelets. Replace damaged saddles.

- s. Locate saddles (3), bolts (4), shackles (5) and nuts (6).
- t. Place shackle (5) over wire rope (8) beyond pulley (7) on span side.
- u. Lift hose (2) end and wrap saddle (3) around hose (2).
- v. Install bolt (4) through eyes of saddle (3), shackle (5), and nut (6). Tighten nut (6) until saddle assembly (3, 4, 5 and 6) is secured to wire rope (8).
- w. Using manila rope (Figure 2-40, 1), pull hoseline (Figure 2-41, 1) across stream (2), gap, or obstruction. Repeat steps p through t, attaching additional saddles (3) to hoseline (1) at 5 foot intervals. Saddles (3) will travel along wire rope (4), providing support for hoseline (1).

2.3.8 Assembly of 10-Mile Hoseline Segment. (Continued)

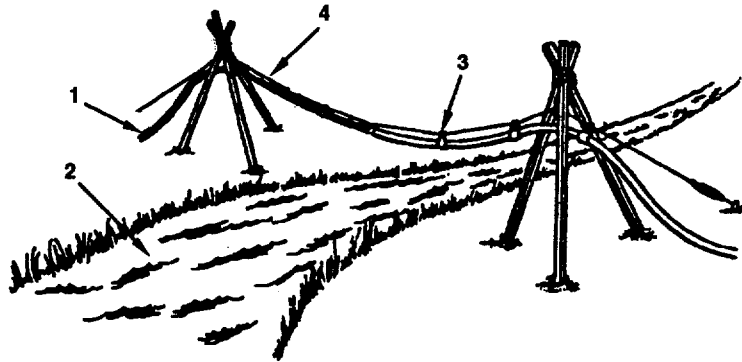


Figure 2-41. Hoseline Installation.

- x. When hoseline (1) is in place, use three or more U-bolt clamps to secure end shackles to wire rope (4).

2.3.8.8 Assembly and Installation of Pressure-Reducing Valve Assembly.

- a. Remove 6 inch grooved pipe couplings (Figure 2-42, 1 and 2), (para 2.3.5.1), connecting hoseline lengths (7 and 8) where pressure-reducing valve assembly (3) is to be installed.
- b. Locate pressure relief valve (4) with attached grooved-end pipe quick disconnect coupling (5). Remove grooved-end pipe quick disconnect coupling (5) (para 2.3.3.1).

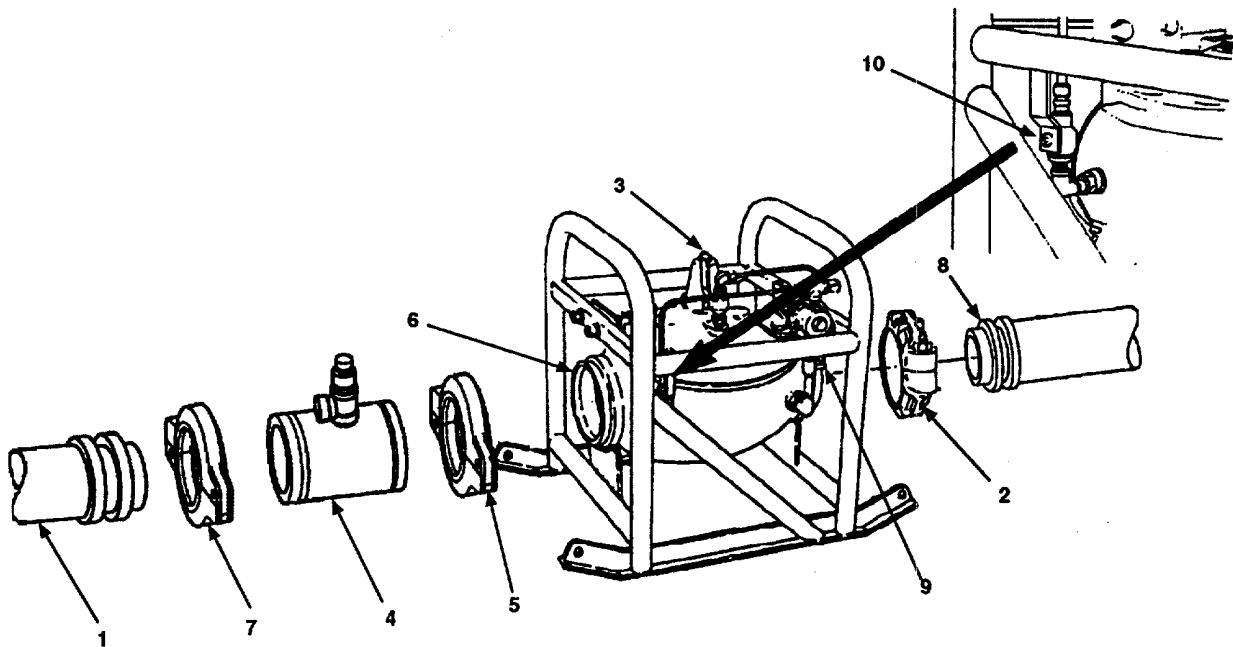


Figure 2-42. Pressure-Reducing Valve Assembly Installation.

WARNING

Ensure opening of pressure relief valve assembly (4) faces downline from pressure-reducing valve assembly (3). Failure to do so may result in personal injury.

NOTE

Inlet connection can be determined by observing the diaphragm rod.

- c. Install pressure relief valve (4) on inlet connection (6) of pressure-reducing valve assembly (3) using grooved-end pipe quick disconnect coupling (5) (para 2.3.3.2) as shown in figure 2-34.
- d. Connect upline hoseline length (7) to pressure relief valve (4) with 6 inch grooved pipe coupling (1) (para 2.3.2.2).
- e. Connect downline hoseline length (8) to outlet connection (9) on pressure-reducing valve assembly (3) with grooved-end pipe quick disconnect coupling (2).
- f. Place all isolation cock valves (10) to open position.

2.4 INITIAL ADJUSTMENTS, CHECKS, AND SELF TEST. There are no initial adjustments, checks or self tests other than the BEFORE (B) PMCS. Perform all BEFORE (B) PMCS prior to operating the TWDS.

2.5 OPERATING PROCEDURES. The operating procedures for the TWDS are provided in paragraphs 2.5.1 through 2.5.5.

2.5.1 TWDS General Operating Procedures. This paragraph provides general instructions for operation of the entire TWDS under usual conditions. Detailed instructions for operation of each major component will be provided in paragraphs 2.5.2 through 2.5.5.

CAUTION

If suction pressure falls below 10 psi or if discharge pressure rises above 150 psi, damage can result to pump.

- a. When packing hoseline, monitor suction and discharge pressures on pumps, refer to applicable technical manual for location of pump suction and pump discharge gauges for the 600 GPM pumping assembly. If pressure is too low or too high, IMMEDIATELY shut down pumps, refer to applicable technical manual for procedures to shut down 600 GPM pumping assembly. Notify supervisors on hose laying crews and operators at other pumping stations who are packing hoseline. Cease operation until problem is corrected.

CAUTION

- Trapped air can cause hoseline to collapse and pressure at downline pumping stations to fall below 10 psi.
 - To prevent damage to pump, take precautions to vent air from hoseline.
- b. As hose-laying crews connect major components, prepare TWDS for operation by packing hoseline. As soon as lead pumping station and first boost pumping station are installed and connected by hoseline, perform the following steps:
 - (1) Refer to applicable technical manual for location of pump suction and pump discharge gauges for the 600 GPM pumping assemblies. Turn petcock on boost pump discharge elbow to the left, until fully opened. This will

2.5.1 TWDS General Operating Procedures. (Continued)

allow air trapped inside hoseline to be vented as water column moves forward.

- (2) Notify operator(s) on lead pumping station to begin pump operation.
 - (3) Observe hoseline for visual indications of approaching water. Listen for air escaping from petcock.
 - (4) Close petcock on discharge elbow when water begins to flow out of petcock.
 - (5) Notify operator(s) on lead pumping station to shut down pump operation.
 - (6) Close butterfly valve on boost pump discharge hose to contain water column.
- c. Begin moving water again when next downline station is installed and connected by hoseline. Open butterfly valve on boost pump discharge hose and repeat applicable steps above. Refer to applicable technical manual and start up lead pump and first boost pump. When water column reaches second boost pumping station, refer to applicable technical manual and close petcock on discharge elbow, shut down pumps, and cease operation of system. Close butterfly valve on second boost pump discharge hose to contain water column.
- d. Continue packing hoseline as each boost pumping station is installed and connected.

NOTE

Before storage tanks are filled, or complete operation of system begins, flush hoseline of sediment and debris.

- e. To protect hose from damage in high winds, do not begin filling storage tanks until hoseline is packed. When system is ready for operation, reference paragraph 2.5.4 for instructions on filling storage tanks.
- f. Complete operation of TWDS can begin as soon as all pumping stations, storage assemblies, and distribution points have been installed and connected.
- g. During startup of the complete system, run all pumps in manual or electric mode, reference applicable technical manual. After startup, boost pumping stations can be operated in electric automatic mode, reference applicable technical manual. However, the lead pump should always be operated in manual mode, reference applicable technical manual for operation of 600 GPM pumping assemblies.
- h. When 20,000 gallon pillow tanks are approaching maximum holding capacity, reduce speed on lead pump to decrease rate of downline water flow, reference applicable technical manual. If operating in electric mode, rate of boost pumps should decrease automatically. When 20,000 gallon pillow tanks are filled to maximum capacity (height of tank reaches 5-1/2 feet), close 4 inch gate valve on each storage assembly.
- i. Operation of distribution points can begin when storage tanks contain enough water to allow a normal discharge rate, para 2.5.5. Pumping rates during operation will vary, depending on amount of water being discharged at either distribution points, large storage and distribution units, or both. Pumping stations operate at intervals long enough to refill 20,000 gallon pillow tanks if discharge rate is minimal. When water is pumped on a continual basis and boost pumping stations are operating in electric automatic mode, perform DURING (D) PMCS on trailer-mounted pump assemblies at a minimum of every 3 hours.

- j. During all phases of operation, operators at pumping stations and storage assemblies must be in communication with each other. Any unusual situations or difficulties must be reported immediately.
 - (1) Since pumps are operated in manual or electric manual modes during startup, operators must monitor suction and discharge pressures on pumps. They must report low suction pressure or high discharge pressure and take corrective action immediately.
 - (2) Storage assembly operators should report beginning and completion of tank filling operations.
 - (3) Operators at lead pumping station should track status of advancing water column during packing operation. During startup, they should monitor overall performance of system.
 - (4) Once operation of complete system begins, operators on each pumping station must continue to monitor suction and discharge pressures. They must report low suction pressure or high discharge pressure and take corrective action immediately.

2.5.2 Operation of Lead Pumping Station. Open butterfly valves on suction and discharge. Refer to applicable technical manual for the operation of the 600 GPM pumping assembly.

2.5.3 Operation of Boost Pumping Station. Open butterfly valves on suction and discharge lines and close the butterfly valve on the bypass line. Reference applicable technical manual for the operation of the 600 GPM pumping assembly.

2.5.4 Operation of Storage Assemblies. Reference applicable technical manual for the operation of 20,000 gallon pillow tank.

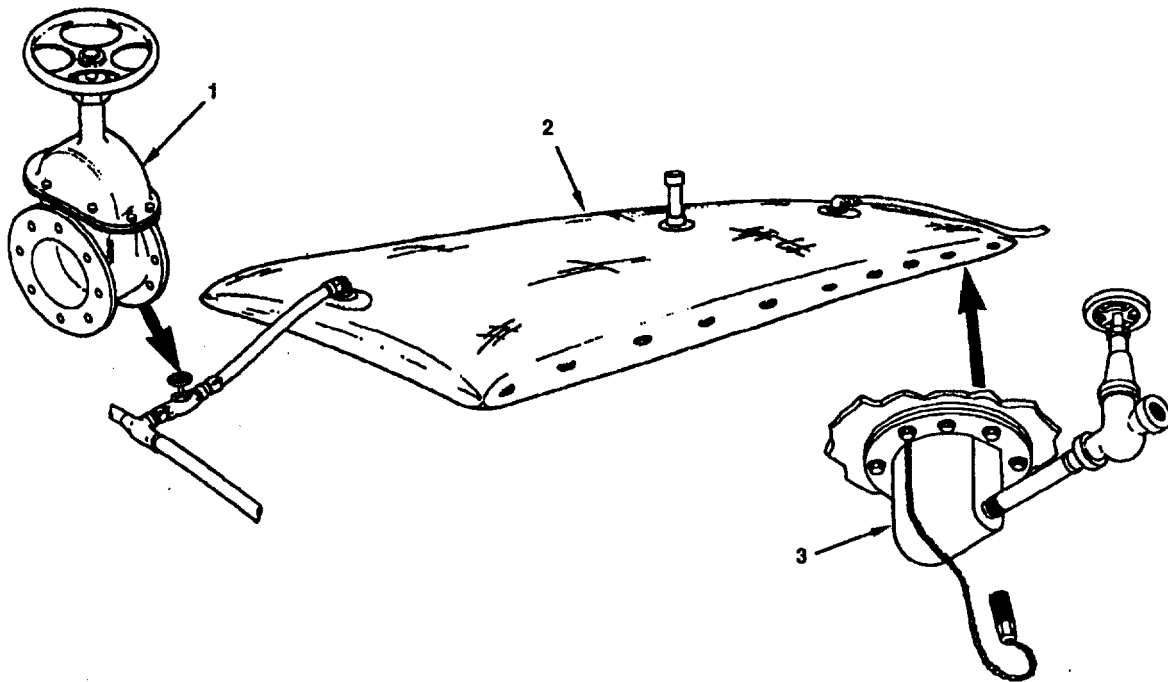


Figure 2-43. 20,000 Gallon Pillow Tank Fill-up.

- a. Open 4 inch gate valve (Figure 2-43, 1) to fill 20,000 gallon pillow tank (2). Check to see that drain valve (3) on 20,000 gallon pillow tank (2) is closed.

2.5.4 Operation of Storage Assemblies. (Continued)

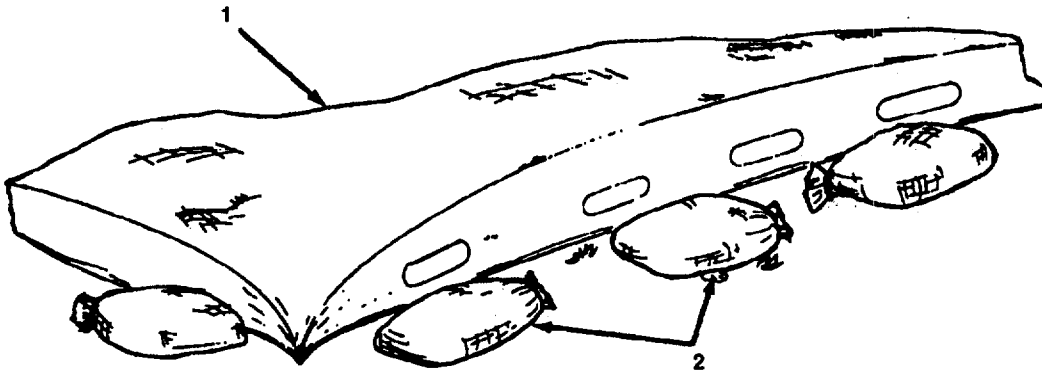


Figure 2-44. Sandbag Installation.

- b. If 20,000 gallon pillow tank (Figure 2-44, 1) rolls when being filled, place sandbags (2) along edge of 20,000 gallon pillow tank (1) to prevent further rolling.
- c. Whenever a 20,000 gallon pillow tank (1) is being filled, inform operators at downline pumping stations to expect reduction in hoseline pressure. The reduction in pressure can cause engines on downline stations to reduce speed. Whenever possible, do not fill 20,000 gallon pillow tank(s) (1) at a rate that causes downline pumping stations to reduce speed.
- d. When 20,000 gallon pillow tank is full, close 4 inch gate valve (Figure 2-43, 1).

2.5.5 Operation of Distribution Points.

2.5.5.1 Distribution Point General Operating Procedures.

- a. Before placing distribution point in operation, determine proper strength of hypochlorite solution, para 2.5.5.3.
- b. After solution strength has been determined, reference applicable technical manual and start 125 GPM pumping assembly. Prepare solution and place hypochlorination unit into operation, paragraphs 2.5.5.4, 2.5.5.5, or 2.5.5.6. When hypochlorination unit has been adjusted, open gate valves in hoseline network. Water may now be distributed at manual disbursing stations.
- c. When distribution point is not being used refer to applicable technical manual and shut down 125 GPM pumping assembly. Hypochlorination unit will stop automatically. Make sure nozzles and elbow valves are hanging from nozzle stand assemblies. If distribution point will not be used for a long period refer to paragraph 2.3.9.2 step an and install dust plugs on elbow valves and nozzles.
- d. If hypochlorination unit stops working properly or residual test, para 2.5.5.7, does not give satisfactory reading, immediately shut down operation of distribution point. Notify other operators and take corrective action.

2.5.5.2 125 GPM Pumping Assembly. Refer to applicable technical manual to operate 125 GPM pumping assembly under usual conditions.

2.5.5.3 Determining Hypochlorite Solution Strength.

NOTE

- Do not confuse the terms "dosage" and "residual."
 - Dosage refers to amount of chlorine added to the water.
 - Residual refers to amount of chlorine remaining in the water after 10 minutes.
- a. Determine desired chlorine dosage or solution strength.
 - b. Check listing on table 2-19. Read across for required quantity of calcium hypochlorite powder needed.
 - c. If chlorine requirement is unknown, start with a 1.0 percent solution strength. Adjust in accordance with chlorine residual tests.

NOTE

Table 2-19 is based on strength of calcium hypochlorite at 70% strength.

Table 2-14. Hypochlorite Solution Strength Index.*

Dosage (ppm)	Solution (%)	Required Quantity of Calcium Hypochlorite (oz.)
0.25	0.05	0.50
0.50	0.10	1.00
0.75	0.20	2.00
1.00	0.25	2.50
1.50	0.375	3.75
2.00	0.475	4.75
2.50	0.60	6.00
3.00	0.725	7.25
3.50	0.825	8.25
4.00	0.95	9.50
5.00	1.00	10.00
10.00	2.50	25.00
15.00	3.50	35.00
20.00	4.75	47.50
25.00	6.00	60.00

* Figures in table 2-19 are based on the following:

- (1) Model 1955-1: 100 gpm maximum flow rate through unit at 24 spm with 50 percent stroke setting.
- (2) Model A-506131: 100 gpm maximum flow rate through unit at 12 spm with 100 percent stroke setting.

2.5.5.4 Operation of Hypochlorination Unit: Model 1955-1.

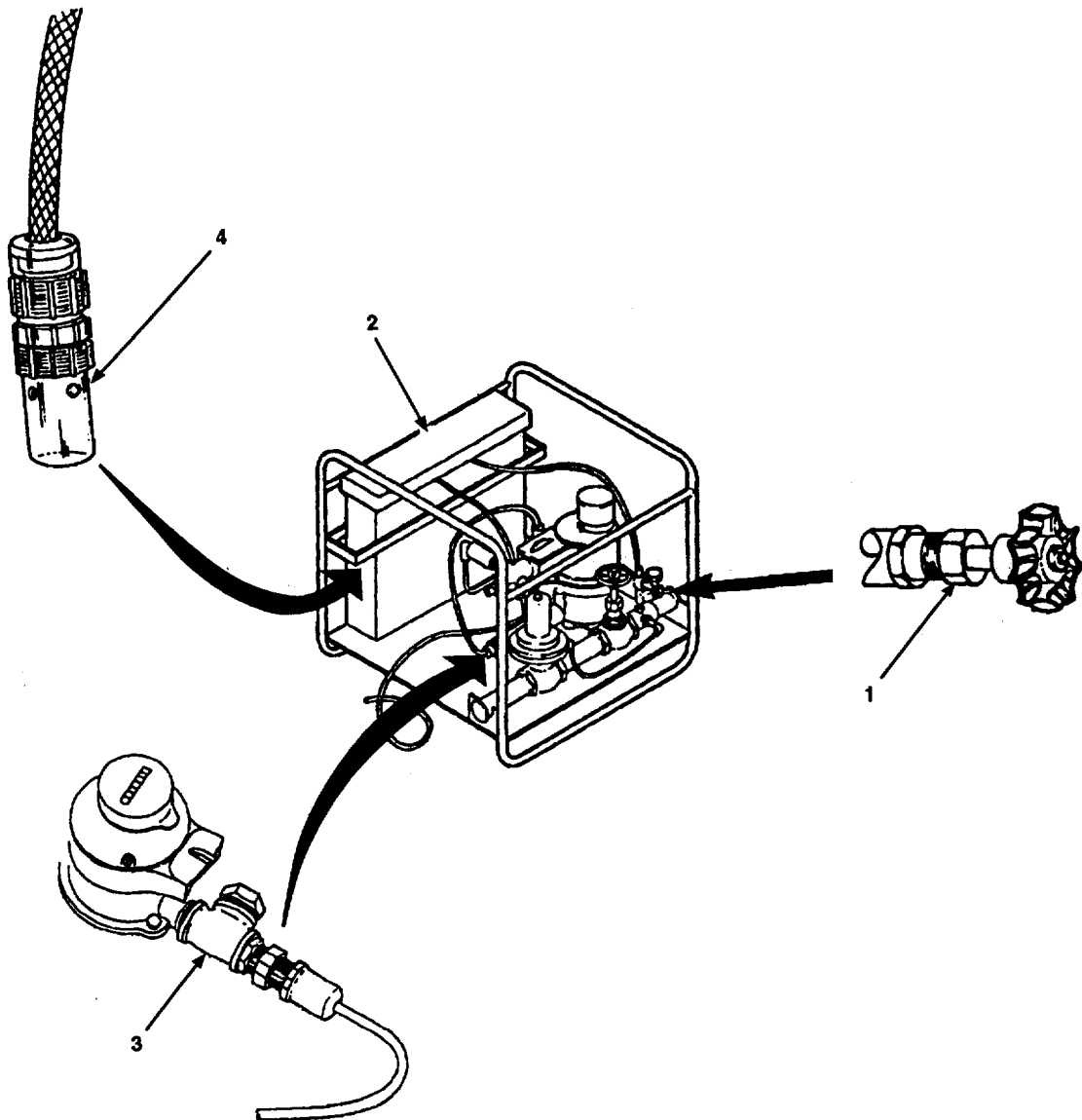


Figure 2-45. Hypochlorination Unit Model 1955-1 Controls and Suction Foot.

WARNING

To keep dirt, sand and grit from contaminating the solution, make sure reservoir is covered by lid.

- a. Open water reservoir fill valve (Figure 2-45, 1) and fill reservoir (2). Close water reservoir fill valve (1) when water reaches "FULL" mark on reservoir (2).

WARNING

- Calcium hypochlorite can cause injury if not handled properly. Heed safety measures below.
 - If calcium hypochlorite comes into contact with skin or eyes, flush right away with water. Seek medical help.
 - Store calcium hypochlorite in a cool, dry place. Keep container closed.
 - Mix only in accordance with directions for use.
 - DO NOT allow calcium hypochlorite to mix with any other materials, such as fuels, oils, paint products, or ammonia. This can cause fire or hazardous gases.
 - Failure to obey this warning may result in personal injury or death.
- b. Add required amount of calcium hypochlorite powder (item 2, appendix E) for desired solution strength, table 2-19, to solution reservoir. Thoroughly mix powder in water.
 - c. Loosen tube nut (3) at injection point.
 - d. Insert foot valve (4) into solution in reservoir (2). Rapidly move foot valve (4) up and down several times to fill suction line (5).
 - e. Tighten tube nut (3) at injection point.

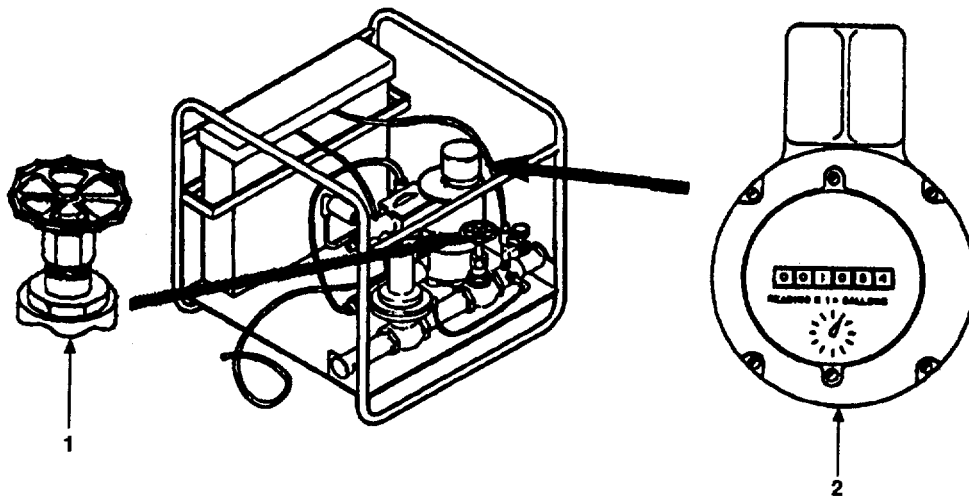


Figure 2-46. Hypochlorination Unit Model 1955-1 Control and Water Meter.

- f. Open range adjusting valve (Figure 2-46, 1).
- g. When flow rate is at maximum, close range adjusting valve (1) slowly until water meter register (2) indicates flow rate of 14 gpm.

2.5.5.4 Operation of Hypochlorination Unit: Model 1955-1. (Continued)

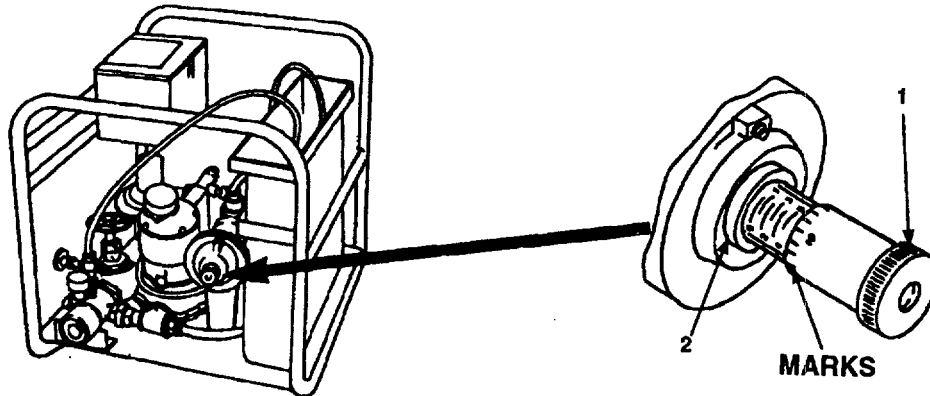


Figure 2-47. Stroke Adjust Thimble Operation.

NOTE

- Stroke adjust thimble is marked to measure revolutions. Turning thimble from 0 to 10 equals one half revolution. Turning thimble from 0 to 20 equals one complete revolution.
 - One half revolution of thimble equals one number setting on micrometer barrel scale. One complete revolution of thimble equals two number settings on micrometer barrel scale.
- h. Turn stroke adjust thimble (Figure 2-47, 1) left two and one half revolutions. Stroke adjust thimble (1) will be set at 5 on micrometer barrel scale (2).
- i. If hypochlorite feeder (Figure 2-48, 1) becomes air-bound after startup:
- (1) Loosen top hose connection (2) on hypochlorite feeder (1).
 - (2) Set stroke adjust thimble (Figure 2-47, 1) to 10 on micrometer barrel scale (2). This allows air to escape through small vent (Figure 2-48, 3) in top of pump (4).
 - (3) When air is vented, set stroke adjust thimble (Figure 2-47, 1) back to 5 on micrometer barrel scale (2).
 - (4) Tighten top hose connection (Figure 2-48, 2) on feeder (1).

NOTE

Thirty minute contact time is required to obtain an accurate chlorine residual as prescribed by TB-MED-577 or by area medical officer.

- j. After unit operates for 10 minutes, take chlorine residual test, para 2.5.5.7.
- k. If residual reading is high:
- (1) Turn stroke adjust thimble (Figure 2-47, 1) setting to 2.5 on micrometer barrel scale (2).
 - (2) Run unit for 10 minutes and take another residual test, para 2.5.5.7.
 - (3) If reading remains high, add water to reservoir (Figure 2-48, 5)

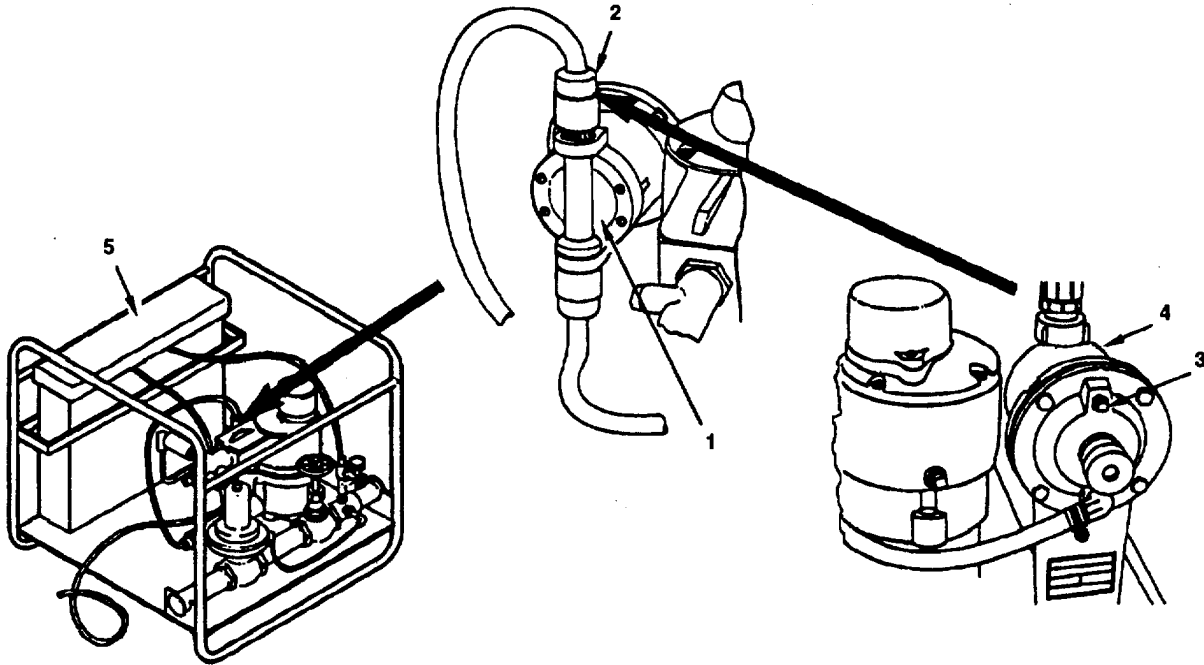


Figure 2-48. Correcting Air-Bound Unit After Startup.

- (4) Run unit for 10 minutes and take residual test, para 2.5.5.7.
 - (5) Continue adding water and repeating tests until desired residual is obtained.
1. If residual reading is low:
- (1) Turn stroke adjust thimble (Figure 2-47, 1) setting to 7.5 on micrometer bar scale (2).
 - (2) Run unit for 10 minutes and repeat residual test, para 2.5.5.7
 - (3) If reading remains low, continue to adjust stroke setting up and perform residual tests until desired residual is obtained.
- m. When residual test, para 2.5.5.7 gives desired reading, no adjustments to unit are required. Check level of solution in reservoir every 30 minutes. When level drops within 2 or 3 inches of foot valve (Figure 2-45, 4), prepare new batch of solution in reservoir (2).
- n. Make residual tests para 2.5.5.7 at frequent intervals to see if desired residual is being maintained. Over an extended period of time, unit requires some adjustment, steps k. or 1. above, to keep residual at desired level. o. To stop unit, close range adjusting valve (Figure 2-46, 1). Hypochlorination unit will not operate when there is no flow through water meter.

2.5.5.5 Operation of Hypochlorination Unit: Model 1955-3. Reference applicable technical manual for operation of hypochlorination unit model 1955-3.

2.5.5.6 Operation of Hypochlorination Unit: Model A-506131. Reference applicable technical manual for operation of hypochlorination unit model A-506131.

2.5.5.7 Performing Chlorine Residual Tests.

- a. Locate color comparator kit.

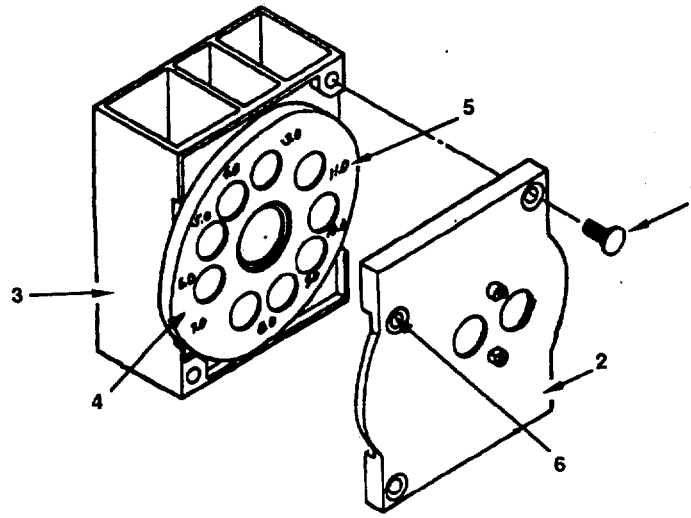


Figure 2-49. Install Chlorine Color Disc.

CAUTION

- If wrong disc is used, chlorine residual test results will be incorrect.
 - Make sure tag on disc reads either DPD CHLORINE or CHLORINE.
- b. Remove two screws (Figure 2-49, 1) and front cover (2) from comparator body (3).
- c. Place chlorine color disc (4) in comparator body (3) with numbers (5) facing outward. Place front cover (2) over chlorine color disc (4). Ensure that number display window (6) is at top of comparator body (3). Install and tighten screws (1).

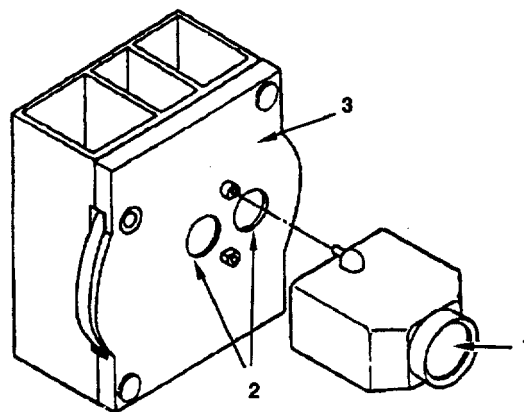


Figure 2-50. Installation of Prism Eyepiece

- d. Place prism eyepiece (Figure 2-50, 1) over sample cell windows (2) on comparator front cover (3).

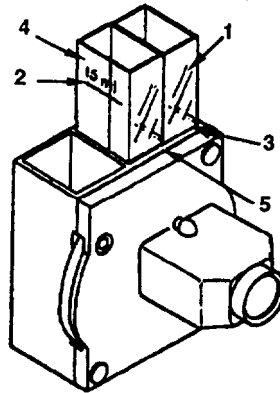


Figure 2-51. Preparation of Sample Cells.

- e. Rinse and fill two clean 15 ml sample cells (Figure 2-51, 1) to 15 ml mark (2) with water from manual disbursing station.
- f. Hold the comparator with the prism eyepiece (Figure 2-50,1) facing you and insert one of the water filled sample cells (Figure 2-51, 1) into the right- hand sample space (3). Insert the second water filled sample cell (4) into the left-hand sample space (5).
- g. Fill the droppers in the arsenite and orthotolidine bottles and let the dropper caps sit loosely in the bottles. Do not screw the caps back on the bottles.

NOTE

Readings must be made within one minute of adding chemical to indicator cell.

- h. Squirt with force one dropper full (not less than 0.75 ml) of arsenite (red cap) solution into the right-hand sample cell (3). Then squirt with force one dropper full (not less than 0.75 ml) of orthotolidine (yellow cap) solution into the right-hand sample cell (3).
- i. Refill the arsenite and orthotolidine droppers and let the droppers sit loosely in the bottles.
- j. Squirt with force the dropper full of orthotolidine (yellow cap) solution into the left hand sample cell (5). Immediately squirt with force the dropper full of arsenite (red cap) solution into the same cell (5). This is the indicator.

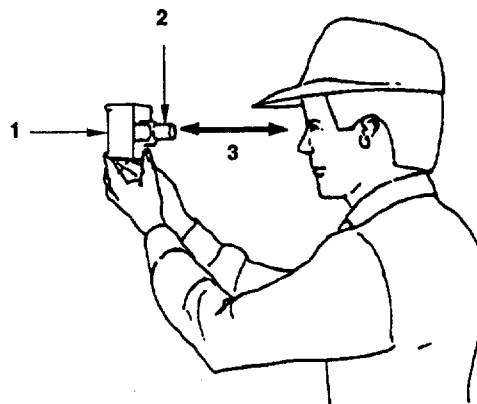


Figure 2-52. Viewing Water Samples

2.5.5.7 Performing Chlorine Residual Tests. (Continued)**CAUTION**

- DO NOT hold comparator to direct sunlight or artificial light when comparing colors. Test results will not be correct.
 - DO NOT cover light window in rear of body.
- k. Hold the comparator (Figure 2-52, 1) to your eye and face a good light source (daylight but not the direct rays of the sun, daylight illuminator or artificial light reflected from a white surface). Look through the prism eyepiece (2) at a distance of about 10 inches (3).
 - l. Rotate chlorine color disk (Figure 2-49, 4) until a color on the disc matches the color on the left hand sample cell or indicator cell (Figure 2-51, 4). The readings can be made directly from the number display window (Figure 2-49, 6). The value is expressed in milligrams per liter (mg/l).
 - m. Record value number shown in number display window (Figure 2-49, 6). If color of indicator cell (Figure 2-51, 4) is between colors on the chlorine color disk (Figure 2-49, 4), the value number must be estimated.
 - n. The readings must be made within one minute of adding the chemicals to the indicator cell.
 - o. When test has been completed, empty the samples and wash the sample cells; (Figure 2-51, 1 and 4) with clean water.
 - p. Remove prism eyepiece (Figure 2-50, 1) and place in kit container.
 - q. Remove two screws (Figure 2-49, 1) and front cover (2) on comparator body (3). Remove chlorine color disc (4) and place in kit container.
 - r. Place front cover (2) on comparator body (3). Install and tighten screws (1) Place color comparator (1, 2, and 3) in kit container. Fasten latch on kit container.
 - s. Store kit in metal box mounted on hypochlorination unit skid.

2.5.5.8 Performing PH Test.

- a. Refer to paragraph 2.5.5.7 and perform steps a through f, ensuring that either the WIDE RANGE INDICATOR-D or pH disc is installed.

CAUTION

- Make sure correct disc is used for pH test. Tag on disc should either read WIDE RANGE INDICATOR-D or pH.
 - If wrong disc is used, test results will be incorrect.
- b. Fill the dropper (Figure 2-53, 1) of the wide range indicator solution white cap) bottle to the 0.50 ml mark (2).
 - c. Using the dropper (1) add the indicator solution to the sample cell (3) in the left-hand cell space (Figure 2-51, 4) only. (Water sample without indicator solution in right opening compensates for color and turbidity.)

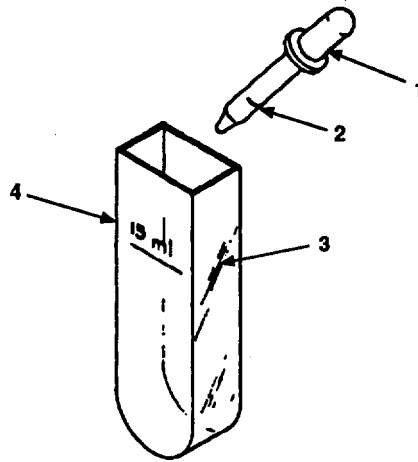


Figure 2-53. pH Indicator.

- d. Refer to paragraph 2.5.5.7 and perform steps k through m, replacing "chlorine color disc" with "ph color disc".
- e. In making the pH test be careful to avoid touching the sample or indicator cell (Figure 2-50, 4) with the dropper (Figure 2-52, 1). Never place the dropper on a laboratory bench or other surface because the adherence of the slightest amount of acid or alkali to it will produce incorrect results.
- f. Refer to paragraph 2.5.5.7 and perform steps o through s.

2.6 DECALS AND INSTRUCTION PLATES. For information on 600 GPM pumping assembly decals and instruction plates reference applicable technical manual.

2.6.1 Hypochlorination Unit: Model 1955-1.

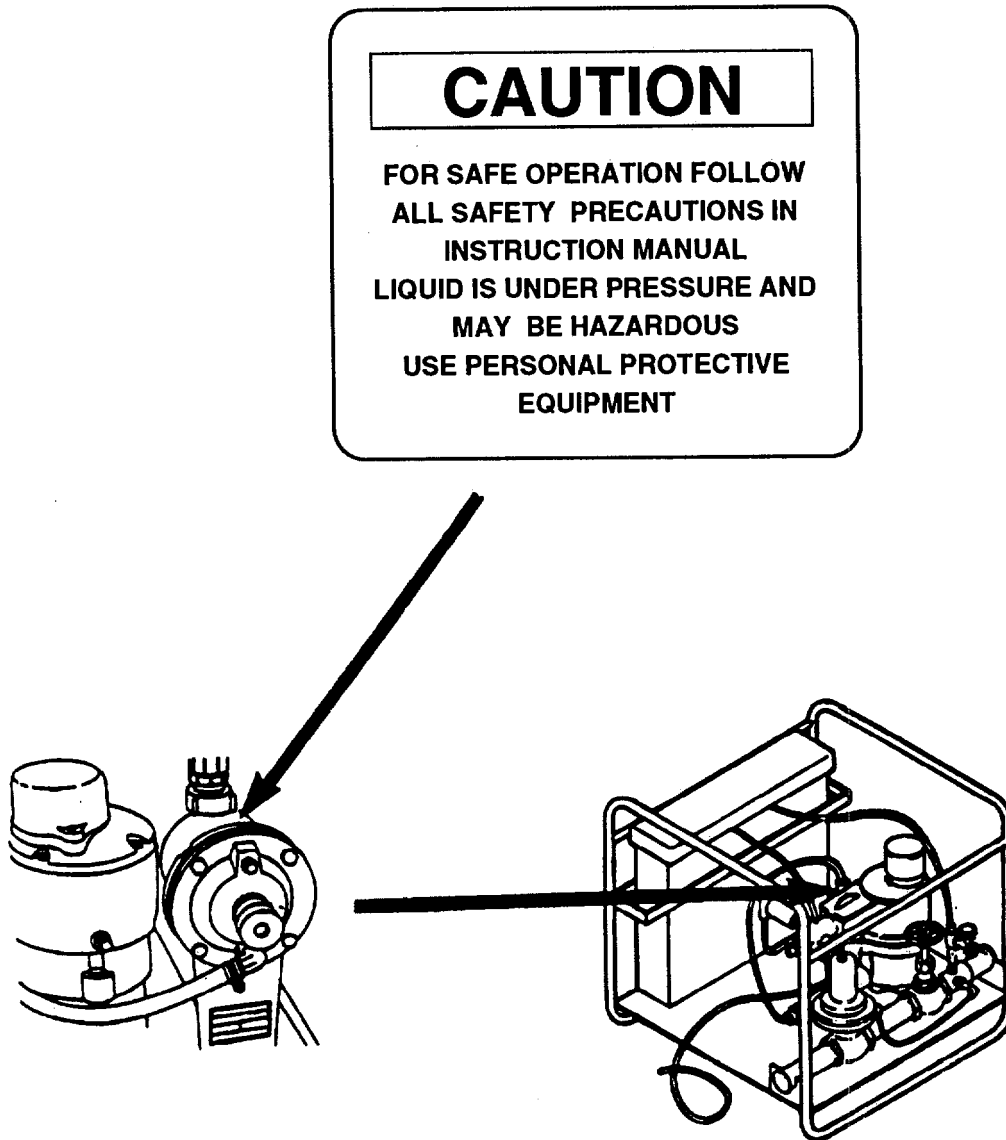


Figure 2-54. Hypochlorination Unit, Model 1955-1 "CAUTION" Plate.

2.6.2 Hypochlorination Unit, Model 1955-3. For decals and instruction plates on hypochlorination unit 1955-3, reference applicable technical manual.

2.6.3 Hypochlorination Unit, Model A-506131. For decals and instruction plates on hypochlorination unit A-506131, reference applicable technical manual.

2.6.4 125 GPM Pumping Assembly. For decals and instruction plates reference applicable technical manual.

2.7 OPERATION OF AUXILIARY EQUIPMENT.

Refer to TM 5-4310-452-14&P for operation of Compressor, Rotary, Air, DED, 250 CFM, 100 PSI, Trailer Mounted, (Item 1, Appendix D).

2.8 PREPARATION FOR MOVEMENT.

2.8.1 Procedures for Preparation for Movement of TWDS. This paragraph provides general information for movement of TWDS equipment. Detailed instructions for the movement of each major component will be provided in paragraphs 2.8.2 through 2.8.6.

- a. Preparing TWDS for movement requires the following:
 - (1) Removing water from system.
 - (2) Shutting down and disassembling major components.
 - (3) Repacking major components.
- b. Remove water at lead pumping station first, then move down the line to the last boost pumping station. After hoseline water has been removed, empty storage tanks and begin to disassemble major components.
- c. To begin emptying hoseline, reference applicable technical manual and shut down lead pump. Close butterfly valves on suction and discharge ports of lead pump. Run boost pumping stations in manual mode until suction pressure drops to 10 psi. Shut down boost pumping stations.

CAUTION

Do not operate 600 gpm pumping assemblies below 10 psi. Damage to 600 gpm pumping assemblies may result if they are operated below 10 psi.

- d. Close butterfly valves on suction and discharge ports of boost pumping stations.
- e. Once all pumping stations have been shut down and isolated from hoseline, use 125 GPM pumping assembly to drain storage tanks. Empty solution from reservoirs on hypochlorination units. Temporarily leave units in operation to flush parts with untreated water. After flushing for 10 minutes, disconnect hypochlorination units and continue to empty storage tanks. Detailed procedures for removing water from storage tanks are provided in paragraph 2.8.6.
- f. Pumping stations can be disassembled when they are shut down. Distribution points can be partially disassembled while storage tanks are being drained, and completely disassembled when tanks are empty. Storage assemblies can be disassembled when tanks are collapsed.
- g. Begin hoseline shutdown at the first 500 foot length and move down the line. Move air compressor down two hose lengths. Evacuate trailing hose, then load hose length to minimize number of times air compressor is to be moved. Repack hoseline lengths when they are evacuated and collapsed. Personnel repacking hoseline segments can follow behind those evacuating and collapsing hoseline. Suspension devices, road crossing guards, and the pressure-reducing valve assembly that were placed along hoseline route are removed when crews reach installation sites.
- h. The pumping stations, storage assemblies, and distribution points can be repacked in any sequence. Pack the 10-mile hoseline segment crate, containing kits required to repack the hoseline, last.
- i. Pack all components for the six pumping stations in one crate, except for trailer-mounted pump assemblies. Refer to applicable technical manual for preparation of movement for 600 GPM pumping assemblies. Collect pumping station components and packing materials at a single site before repacking crate. Otherwise, all packing materials must be shuttled to each installation site for packing.

2.8.1 Procedures for Preparation for Movement of TWDS. (Continued)

- j. Pack all components for the two storage assemblies, except 20,000 gallon pillow tanks, together in one crate. Collect all components for both storage assemblies and all packing materials at a single site before repacking crate.
- k. Pack all components for two distribution points, except 125 GPM pumping assemblies, in one crate. Refer to applicable technical manual for preparation for movement of 125 GPM pumping assembly. Collect all components for both distribution points at a single site before repacking crate.
- l. Pack all components for the 10-mile hoseline segment, except for hoseline and flaking boxes, in one crate. Collect all 10-mile hoseline segment components at a single site before repacking crate.
- m. Packing TWDS requires the following general steps:
 - (1) Remove lids from crates. As required, remove blocking, bracing, anchoring, packing materials, and fiberboard and plywood boxes stored in each crate.
 - (2) Return components to original containers, reference paragraph 2.3.4.
 - (3) Pack fiberboard boxes in plywood boxes.
 - (4) Install blocking, bracing, and anchoring securing contents within each crate as required.
 - (5) Install plywood sheathing on top of each crate. Nail down plywood sheathing.
 - (6) Roll out polyethylene barrier and position over plywood sheathing on top of each crate.
 - (7) Install cross-sheathing boards on top of each crate. Nail down cross-sheathing boards.
- n. After repacking, TWDS is ready for movement to another location.

2.8.2 Preparation for Movement of 10-Mile Hoseline.**2.8.2.1 Disassembly and Packing Requirements.**

- a. Disassembly for the 10-mile hoseline segment requires sufficient tools, equipment, and personnel to perform the tasks outlined in paragraph 2.3.10. The displacement and evacuation kit, and the packing kit will be required to pack hoseline segments in flaking boxes. If a forklift is not available, the lifting sling will be required to load, unload, and stack flaking boxes.
- b. When flaking boxes are returned to packing site, stack them in groups of four. Pack each group in crate marked HOSE ASSEMBLY, 6 INCH, 500 FEET. (Number of groups packed in crates will depend on number of hoseline segments used during TWDS operation.) Reference Table 2-11 for the total number, size, and type of components packed in the "10-MILE SEGMENT" Crate. Repack components that were removed for TWDS operation and/or disassembly.

2.8.2.2 Disconnecting and Evacuating Hoseline.**NOTE**

Begin evacuating hoseline at lead pumping station and proceed downline.

- a. Remove grooved-end pipe quick disconnect coupling clamp (Figure 2-55, 1) (para 2.3.3.1) connecting end of hoseline segment (2) to next downline hose segment (3) or swivel joint.

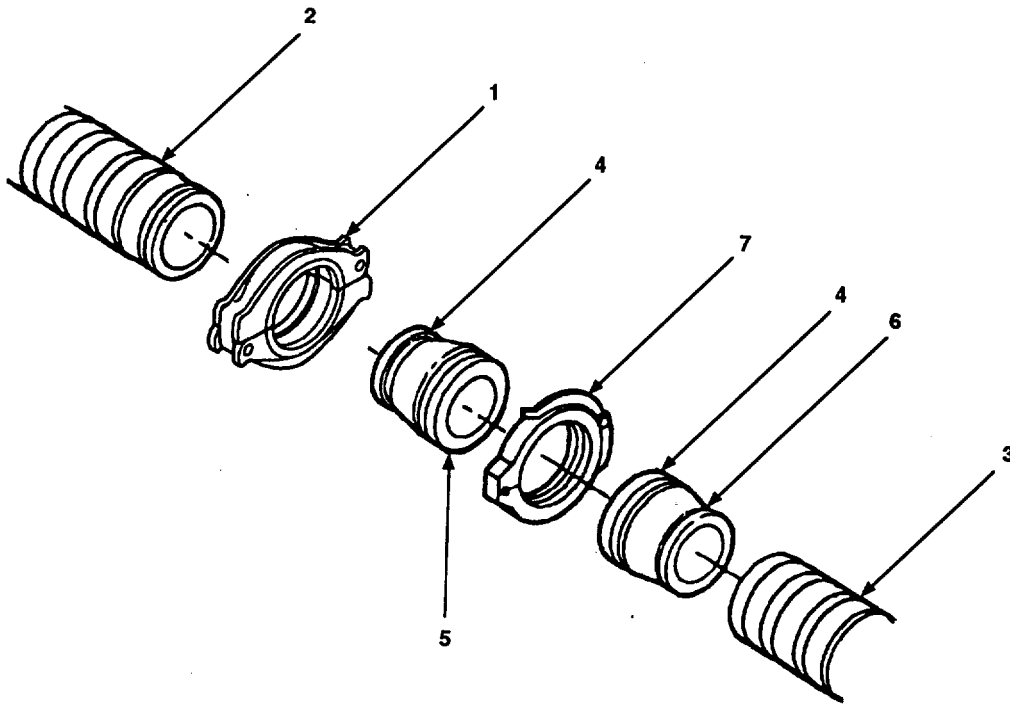


Figure 2-55. Ball Receiver Installation.

- b. Separate two hoseline segments (2 and 3) (or hoseline segment and swivel joint).
- c. Locate ball receiver (4), consisting of two 8 X 6 inch reducers (5 and 6). One reducer (6) has been modified to prevent displacement ball from being ejected from ball receiver (4).
- d. Connect 6 inch end of unmodified reducer (5) to downline end of first hoseline segment (2) using grooved-end pipe quick disconnect coupling clamp (1) (para 2.3.3.2).
- e. Locate 8 inch snaplock coupling (7). Open coupling.
- f. Fit snaplock coupling halves (7) over joined ends of reducers (5 and 6). Close coupling halves (7) over reducer (5 and 6) ends. Lock snap lock coupling halves (7).
- g. Connect nipple (Figure 2-56, 1) to upline end of first hoseline segment (2) using grooved-end pipe quick disconnect coupling clamp (3) (para 2.3.3.2).
- h. Place displacement ball (4) inside nipple (1).
- i. Locate pneumatic coupler (5) and modified end cap (6) (with tapped hole). Attach pneumatic coupler (5) to end cap (6).
- j. Connect end cap (6) with pneumatic coupler (5) to end of nipple (1). Use grooved-end pipe quick disconnect coupling clamp (7) (para 2.3.3.2) from displacement and evacuation kit.
- k. Locate pneumatic coupler (8). Screw pneumatic coupler (8) into air compressor line (9).

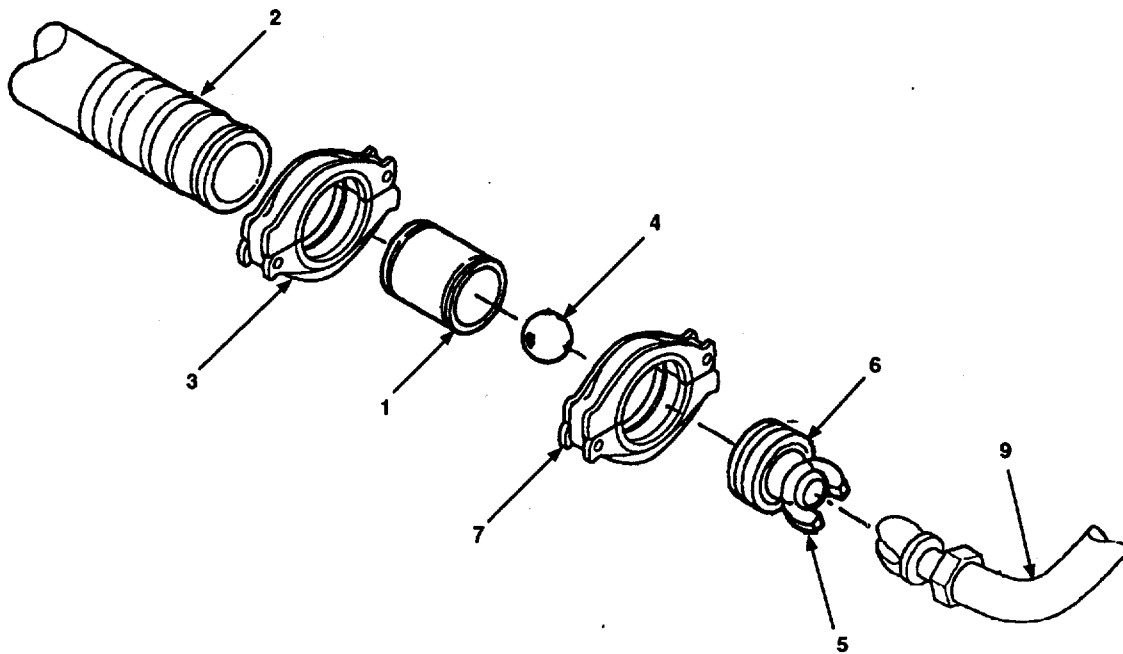


Figure 2-56. Pneumatic Coupler Installation.

WARNING

Stand clear of receiver during displacement process. Hoseline jumps when ball arrives at receiver. Failure to obey this warning may result in personal injury.

- i. Connect pneumatic coupler (8) to pneumatic coupler (5) on end cap (6). Pressurize hoseline to 80 to 90 psi. Displacement ball (4) will be forced through hose, displacing any residual water. A sound will be heard when the displacement ball (4) reaches receiver (Figure 2-52, 4).

NOTE

- If ball gets stuck, straighten kinks in hoseline.
 - It may be necessary to increase air pressure. DO NOT exceed 150 psi.
- m. Shut off compressor when displacement ball (Figure 2-56, 4) reaches receiver (Figure 2-55, 3).
 - n. Open snaplock coupling (Figure 2-55, 7) connecting two reducers (5 and 6). Pull snaplock coupling (7) back and separate two hinged coupling halves of snaplock coupling (7). Set snaplock coupling (7), displacement ball (Figure 2-56, 4), and modified reducer (Figure 2-55, 6) aside.
 - o. Remove grooved-end pipe quick disconnect coupling clamp (1) (para 2.3.3.1) connecting unmodified reducer (5) to hoseline segment (2).

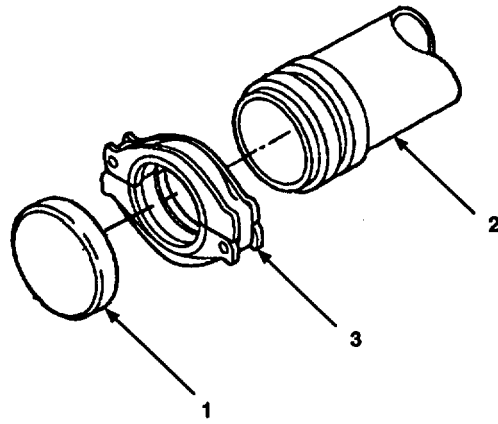


Figure 2-57. End Cap Installation.

- p. Locate end cap (Figure 2-57, 1). Connect end cap (1) to end of hoseline segment (2) using grooved-end pipe quick disconnect coupling clamp (3) (para 2.3.3.2).
- q. Disconnect air compressor line (Figure 2-56, 9) with pneumatic coupler (8) from pneumatic coupler (5) on end cap (6).

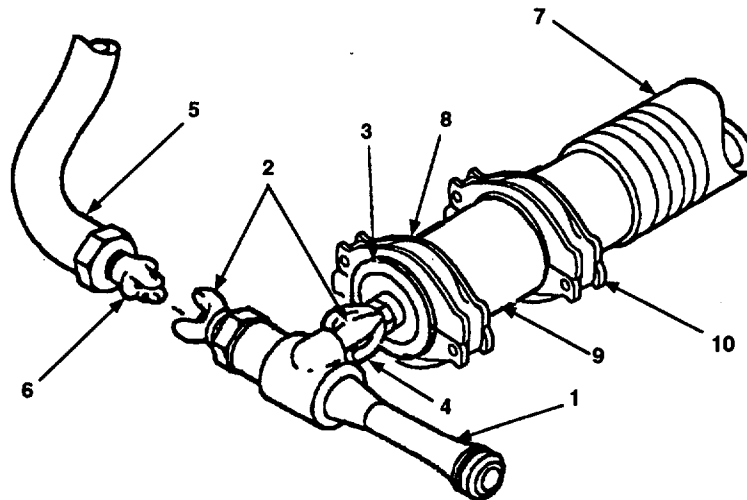


Figure 2-58. Collapsing Hoseline.

- r. Locate ejector assembly (Figure 2-58, 1) and two pneumatic couplers (2). Install pneumatic couplers (2) on threaded fittings on ejector assembly (1).
- s. Install ejector assembly (1) on end cap (3) with pneumatic coupler (4).
- t. Connect air compressor line (5) with pneumatic coupler (6) to ejector assembly (1).
- u. Apply air pressure to ejector assembly (1). Operate compressor for 10 minutes to collapse hoseline (7) for repacking.
- v. Turn off air compressor and disconnect air compressor line (5) with pneumatic coupler (6).
- w. Disconnect ejector assembly (1) and set aside.

2.8.2 Preparation for Movement of 10-Mile Hoseline. (Continued)

- x. Remove grooved-end pipe quick disconnect coupling clamp (8) (para 2.3.3.1) connecting end cap (3) with pneumatic coupler (4) to nipple (9).
- y. Remove grooved-end pipe quick disconnect coupling clamp (10) (para 2.3.3.1) connecting nipple (9) to hoseline segment (7).

NOTE

End caps must be installed on collapsed hoseline to prevent hose from expanding before it is packed.

- z. Connect end cap (Figure 2-57, 1) to hoseline segment (Figure 2-58, 7) using grooved-end pipe quick disconnect coupling (10) (para 2.3.3.2).
- aa. Repeat steps a through z for each downline hoseline segment. Move air compressor down two hose lengths. Evacuate trailing hose then lead hose length to minimize number of times air compressor is to be moved.
- ab. When a hoseline length has been evacuated, collapsed, and capped, it is ready for packing in a flaking box.
- ac. When a swivel joint is removed, return it and one grooved-end pipe quick disconnect coupling clamp to lead pumping station installation site.

2.8.2.3 Repacking Hoseline Segments in Flaking Box Assemblies.**CAUTION**

Clear sharp objects out of flaking box before packing. Any object pressed against hose during packing could puncture it.

- a. Clean empty flaking box assembly (Figure 2-59, 1).

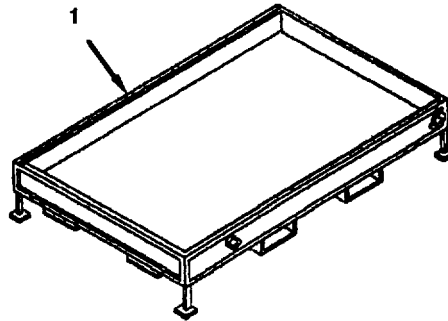


Figure 2-59. Flaking Box Assembly Preparation.

- b. Perform steps a and b or c of paragraph 2.3.8.4 to load empty flaking box on truck.
- c. Transport empty flaking box and packing kit to leading end of first hoseline length.

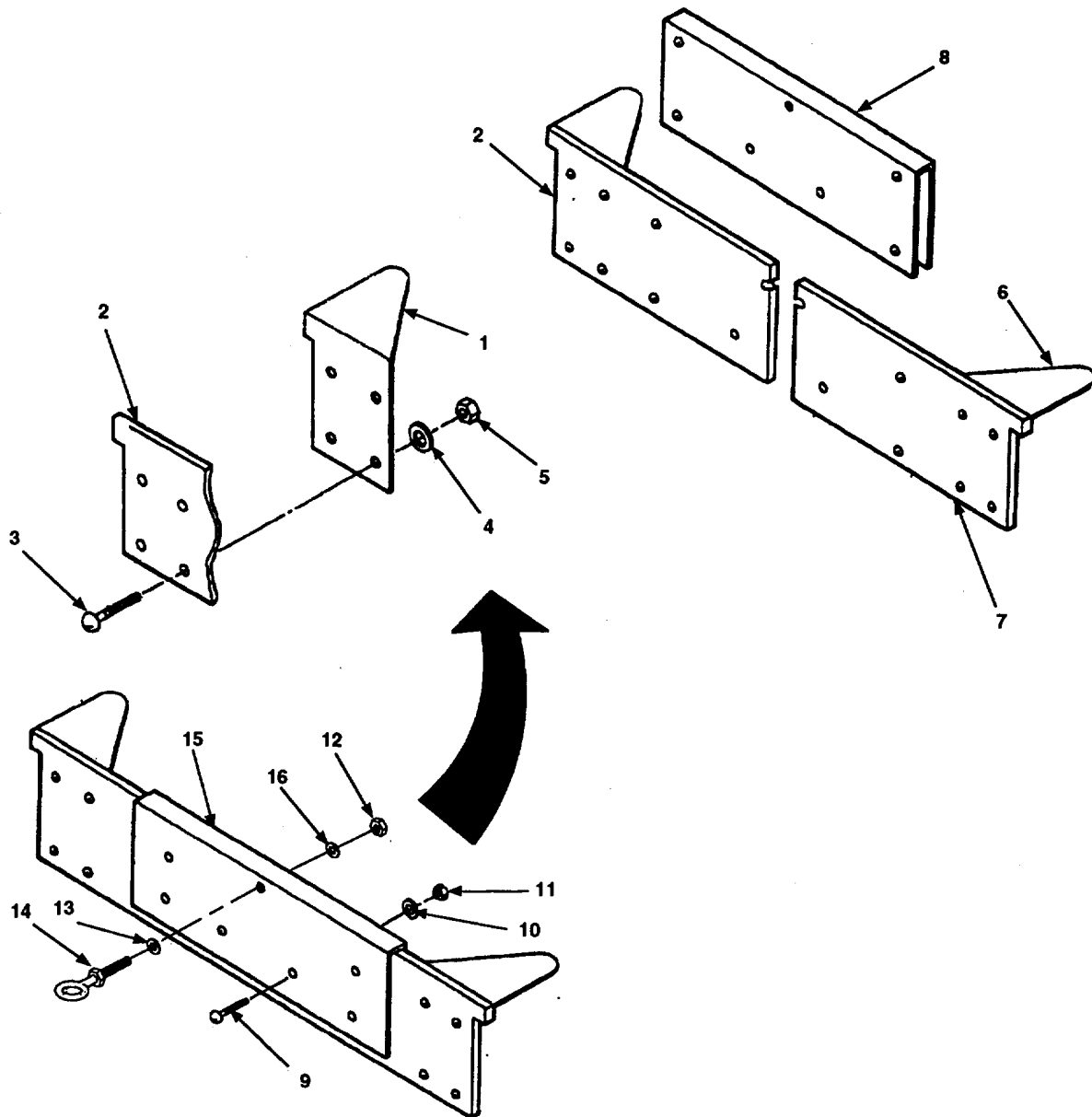


Figure 2-60. Pullboard Flange and Coupling Sleeve Installation.

- d. Remove the following from packing kit: 2 hose-retaining clamps, 2 pullboard halves, 2 pullboard flanges, 1 coupling sleeve, 14 hex nuts, 14 flat washers, 8 square-neck bolts, 6 cap screws, 14 self-locking nuts, 1 chain hoist, 2 eyebolts, 4 nuts, and 4 flat washers.

- (1) Remove screws on front of flaking box that secure tie bar to box.
- (2) Lift and remove tie bar from box.

NOTE

Steps e through m are for pullboard assembly.

- e. Align holes on left pullboard flange (Figure 2-60, 1) with holes on pullboard half (2).

2.8.2 Preparation for Movement of 10-Mile Hoseline. (Continued)

- f. Install four square-neck bolts (3), flat washers (4), and self-locking nuts (5) in holes.
- g. Tighten each nut (5) until heads on bolts (3) are flush with surface of pullboard half (2).
- h. Repeat steps e through g to install right pullboard flange (6) on second pullboard half (7).
- i. Place pullboard halves (2 and 7) in coupling sleeve (8). Align holes in pullboard halves (2 and 7) with holes in coupling sleeve (8).
- j. Install six cap screws (9), flat washers (10), and self-locking nuts (11) in holes.
- k. Tighten each self locking nut (11) until pullboard halves (2 and 7) are firmly secured in coupling sleeve (8).
- l. Install nut (12) and flat washer (13) on eyebolt (14).

NOTE

When installing eyebolt through coupling sleeve, make sure eyebolt and flanges are on opposite sides of pullboard.

- m. Place eyebolt (14) through hole in top of coupling sleeve (8). Install flat washer (15) and nut (16).

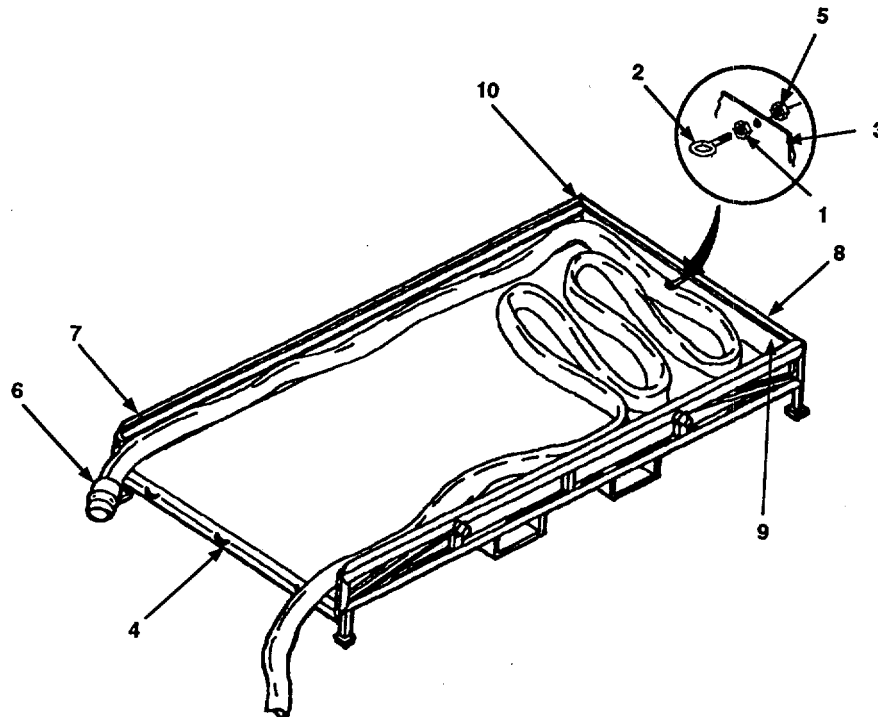


Figure 2-61. Start Hoseline Packing.

- n. Install nut (Figure 2-61, 1) on eyebolt (2). Turn nut (1) to its limit of travel.

- o. Place eyebolt (2) through hole in permanent end wall (3) of flaking box assembly (4). Place nut (5) on eyebolt (2). Tighten nut (5) until eyebolt (2) is securely fastened to flaking box assembly (4).

CAUTION

Clear sharp objects out of flaking box before packing. Any object pressed against hose during packing could puncture it.

- p. Place leading end of hose (6) at left front corner (7) of flaking box assembly (4). Leave about 3 feet of hose dangling beyond front of flaking box assembly (4).
- q. Route hose (6) along left side and then across rear (8) off flaking box assembly (4).
- r. At right rear corner (9) of flaking box assembly (4), fold hose (6) back to left rear corner (10). Then fold hose back to right rear corner (9).
- s. Continue to fold hose (6) in a right-to-left/left-to-right pattern. Make every other fold 1/2 inch shorter than width of flaking box assembly (4).
- t. Stop flaking hose (6) after about 150 feet of hose (6) is in flaking box assembly (4).

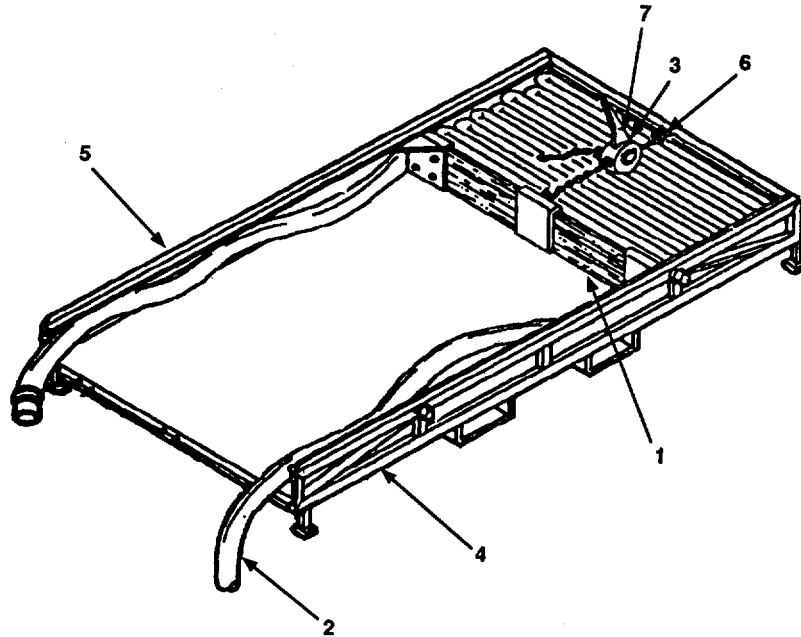


Figure 2-62. compress Hoseline.

- u. Place pullboard assembly (Figure 2-62, 1) against hose (2). Make sure eyebolt (Figure 2-60, 14) on pullboard assembly (Figure 2-62, 1) faces eyebolt (3) on rear of flaking box assembly (4). Position pullboard flanges (Figure 2-60, 1 and 6) beneath metal rim (Figure 2-62, 5) on inside of flaking box assembly (4).
- v. Attach hook (6) of chain hoist (7) to eyebolt (3) in rear of flaking box assembly (4).
- w. Attach hook (8) of chain hoist (7) to eyebolt (Figure 2-60, 14) on pullboard assembly (Figure 2-62, 1).

2.8.2 Preparation for Movement of 10-Mile Hoseline. (Continued)

CAUTION

Be careful not to bend pullboard assembly when compressing hose.

- x. Crank ratchet handle of chain hoist (7) until hose (2) is compressed into one-third of space in flaking box assembly (4).

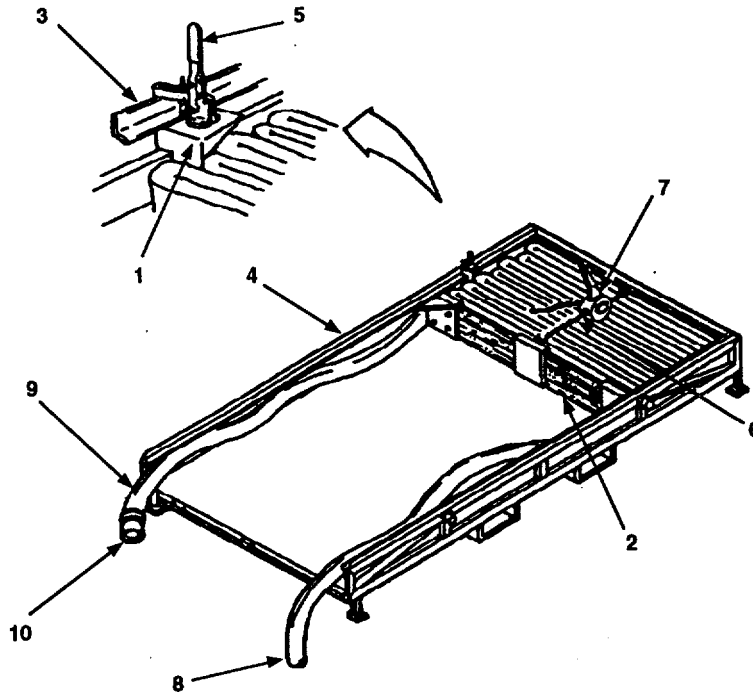


Figure 2-63. Hose Retaining Bracket Installation.

- y. Place two hose-retaining brackets (Figure 2-63, 1) one or two folds in front of pullboard assembly (2). Position brackets on top of metal rim (3) on inside of flaking box assembly (4).
- z. Push up on toggle levers (5), locking brackets (1) against metal rim (3) on inside of flaking box assembly (4).
- aa. Release chain (6) on hoist (7). Remove pullboard assembly (2) from hoist (7).
- ab. Flake next 150 feet of hose (8) into flaking box assembly (4). Repeating steps u through x, compress hose (8) into two-thirds of space in flaking box assembly (4).
- ac. Push down on two toggle levers (5) and remove two hose-retaining brackets (1) (installed in step y).
- ad. Reinstall two hose-retaining brackets (1) one or two folds in front of pullboard assembly (2).
- ae. Push up on two toggle levers (5) and lock two hose-retaining brackets (1) against metal rim (3) on inside of flaking box assembly (4).
- af. Release chain (6) on hoist (7). Remove pullboard assembly (2) from hoist (7).
- ag. Flake remaining hose (8) into flaking box assembly (4). Repeating steps u through x, compress hose into remaining space in flaking box assembly (4).

- ah. Push down on two toggle levers (5) and remove two hose-retaining brackets (1) (installed in step ad).
- ai. Install two hose-retaining brackets (1) one or two folds in front of pullboard assembly (2).
- aj. Push up on two toggle levers (5) and lock hose-retaining brackets (1) against metal rim (3) on inside of flaking box assembly (4).
- ak. Release chain (6) on hoist (7). Remove pullboard assembly (2) from hoist (7). Set pullboard assembly (2) and hoist aside (7).
- al. Remove 6 inch grooved pipe coupling (9) (para 2.3.2.1) on leading end of hoseline (8). Remove end cap (10).
- am. Place plastic cap on leading end of hoseline (8).
- an. Repeat steps al and am for trailing end of hoseline (8)
- ao. Install 6 inch grooved pipe coupling (9) (para 2.3.2.2) on end of trailing end of hoseline (8).
- ap. Deliver end caps and grooved pipe coupling (removed in step al) to crews evacuating hoseline.

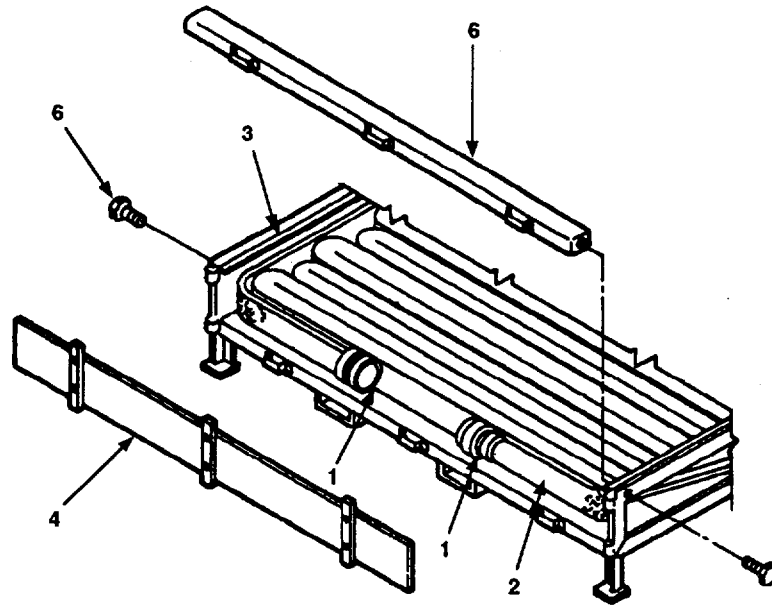


Figure 2-64. Tailgate Assembly Installation.

- aq. Fold ends (Figure 2-64, 1) of hoseline (2) into flaking box assembly (3).
- ar. Insert tailgate assembly (4) into cleats on lower frame of flaking box assembly (3).
- as. Install tie bar (5) on flaking box assembly (3) so that tailgate assembly (4) fits into cleats on tie bar (5).
- at. Install two screws (6) on rear of flaking box assembly (3). Tighten two screws (6) until tie bar (5) is securely fastened to flaking box assembly (3).

2.8.2 Preparation for Movement of 10-Mile Hoseline. (Continued)

- au. Push down on two toggle levers (Figure 2-63, 5) and remove hose retaining brackets (1) (installed in step ai.).
- av. Remove nut (Figure 2-61, 5), eyebolt (2) and nut (1) from rear of flaking box assembly (8).
- aw. Load and nest empty flaking box assembly on top of full flaking box assembly (8). Repeating steps n through aw, pack next length of hoseline. Continue this procedure until all remaining lengths of hoseline have been packed.
- ax. As flaking box assemblies are packed, transport them to lead pumping station installation site for packing in crates.

2.8.2.4 Preparation for Movement of Suspension Device.

NOTE

Set aside all removed components for repacking.

- a. Remove 6 inch grooved pipe coupling (para 2.3.2.1) connecting upline hoseline length to suspended hoseline length.
- b. Install 6 inch grooved pipe coupling (para 2.3.2.2) on leading end of suspended hoseline length.
- c. Repeat steps a and b with trailing end of suspended hoseline length and downline hoseline segment installing 6 inch grooved pipe coupling on leading end of downline segment.

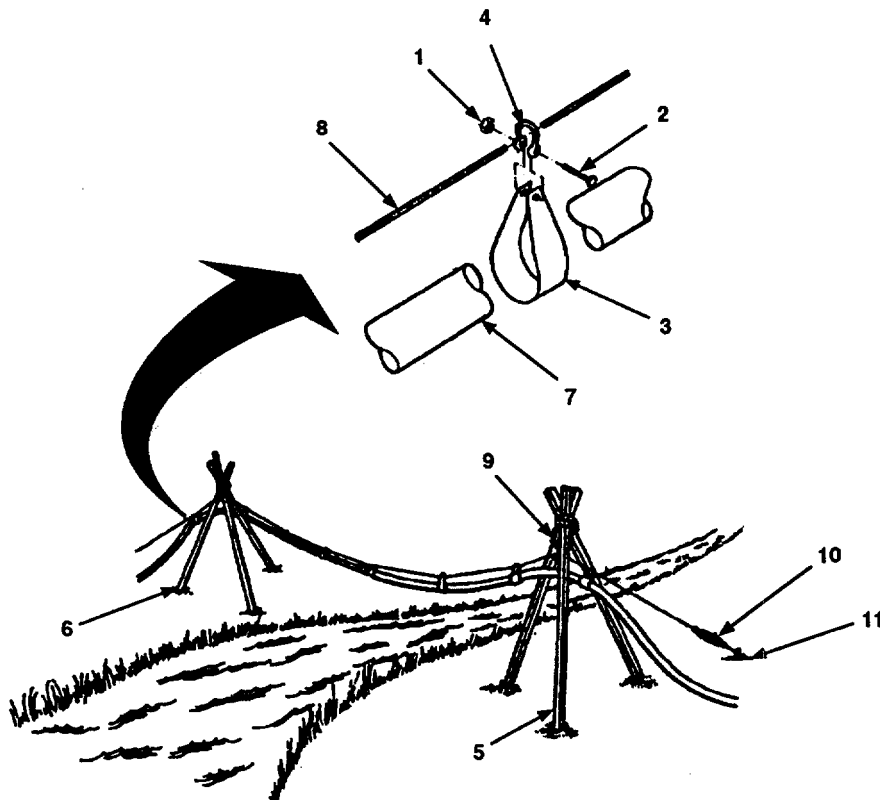


Figure 2-65. Disassembly of Suspension Device.

WARNING

When removing saddle assemblies, manually support hose until assemblies have been removed.

- d. Remove nut (Figure 2-65, 1), bolt (2), saddle (3), and shackle (4) from each saddle assembly to outside of upline tripod (5).
- e. Install bolts (2) through saddles (3) and shackles (4).
- f. Install nut (1) on bolt (2). Tighten nut (1).
- g. Repeat steps d through f for each saddle assembly to outside of downline tripod (6).
- h. Remove three or more U-bolt clamps used to secure end shackles to wire rope.
- i. Pull hose (7) across span. Saddles (3) should drag with hose (7) along wire rope (8).
- j. As saddles (3) arrive at pulley block (9) on tripod tower (5), perform steps d through f.
- k. After all saddles (3) have been removed and hose (7) has been retrieved, loosen turnbuckles (10) to release tension on wire rope (8).
- l. Remove turnbuckles (10) from ends of wire rope (8).
- m. Remove turnbuckles (10) from stakes (11) and remove stakes (11).
- n. Pull wire rope (8) across span and coil it.
- o. Remove two nuts (Figure 2-39, 4), clamps (5), U-bolts (6) and thimble (3) from each end of wire rope (Figure 2-65, 8).
- p. Install one clamp (Figure 2-39, 5) and two nuts (4) on each U-bolt (6).
- q. Remove pulley blocks (Figure 2-65, 9) from tripods (5 and 6).
- r. Disassemble tripods (5 and 6).
- s. Locate chests for suspension kits and remove any contents.
- t. Wipe out inside of chest and clean kit items.
- u. Using loading diagram on chest lid, pack kit items as indicated.
- v. Transport suspension kit chest to lead pumping station installation site for final packing.

2.8.2.5 Preparation for Movement of Road Crossing Guards.**NOTE**

Road crossing guards should be removed and packed after buried hoseline has been pulled free from guards.

- a. Dig out road crossing guards (Figure 2-66, 1).
- b. If planks (2) were nailed to bottom of road crossing guards (1), remove nails and remove planks (2).

2.8.2 Preparation for Movement of 10-Mile Hoseline. (Continued)

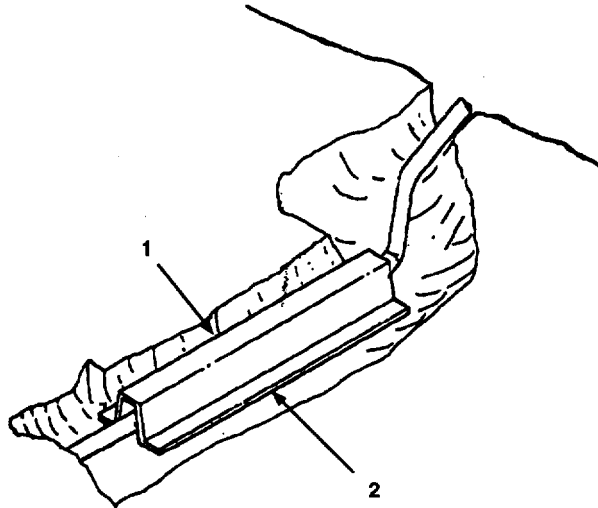


Figure 2-66. Disassembly of Road Crossing Guard.

- c. Clean road crossing guards (1) and transport them to lead pumping installation site for final packing.

2.8.2.6 Preparation for Movement of Pressure-Reducing Valve Assembly.

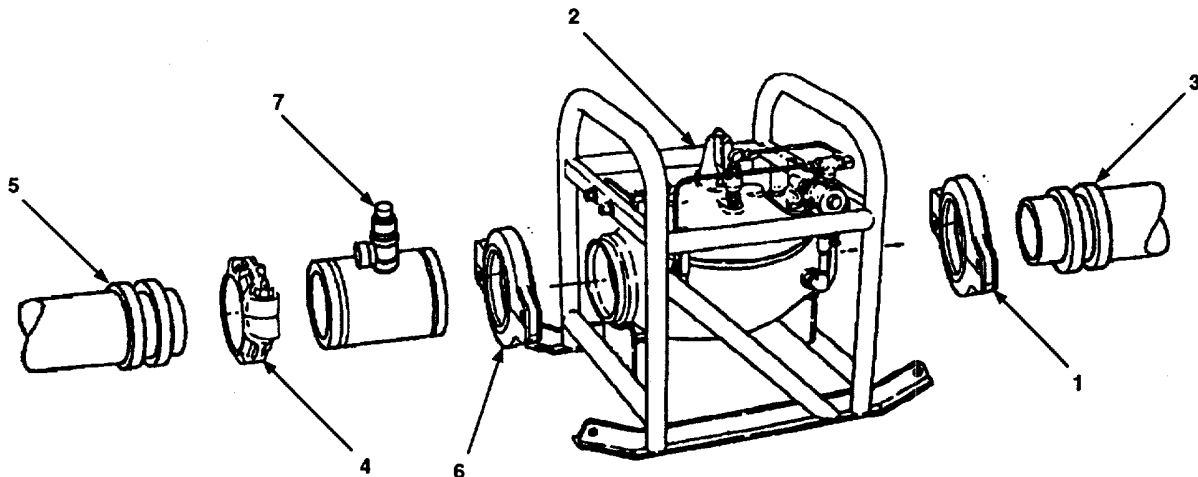


Figure 2-67. Disassembly of Pressure-Reducing Valve Assembly.

NOTE

- Set aside all removed components for repacking.
 - Notify unit maintenance for removal of threaded pipe fittings.
- a. Remove grooved-end quick disconnect coupling clamp (Figure 2-67, 1) (para 2.3.3.1) connecting pressure-reducing valve assembly (2) to downline hoseline segment (3).

- b. Install grooved-end quick disconnect coupling clamp (1) (para 2.3.3.2) on end of hoseline segment (3).
- c. Remove grooved-end quick disconnect coupling clamp (4) (para 2.3.3.1) connecting pressure relief valve assembly (7) to upline hoseline segment (5).
- d. Remove grooved-end quick disconnect coupling clamp (6) (para 2.3.3.1) connecting pressure- relief valve assembly (7) to pressure-reducing valve assembly (2).

2.8.3 Preparation for Movement of Lead Pumping Station. This is a general procedure for moving the lead pumping station. For information pertaining to moving the 600 GPM pumping assembly, reference applicable technical manuals.

2.8.3.1 Disassembly Requirements. Disassembly of the lead pumping station requires the tools and personnel referenced in paragraph 2.3.4.1. Pack the components listed in tables 2-8 and 2-9 in the "PUMPING STATION CRATE" and the "10-MILE SEGMENT CRATE" after removing them from the lead pumping station.

2.8.3.2 Disassembly Procedures.

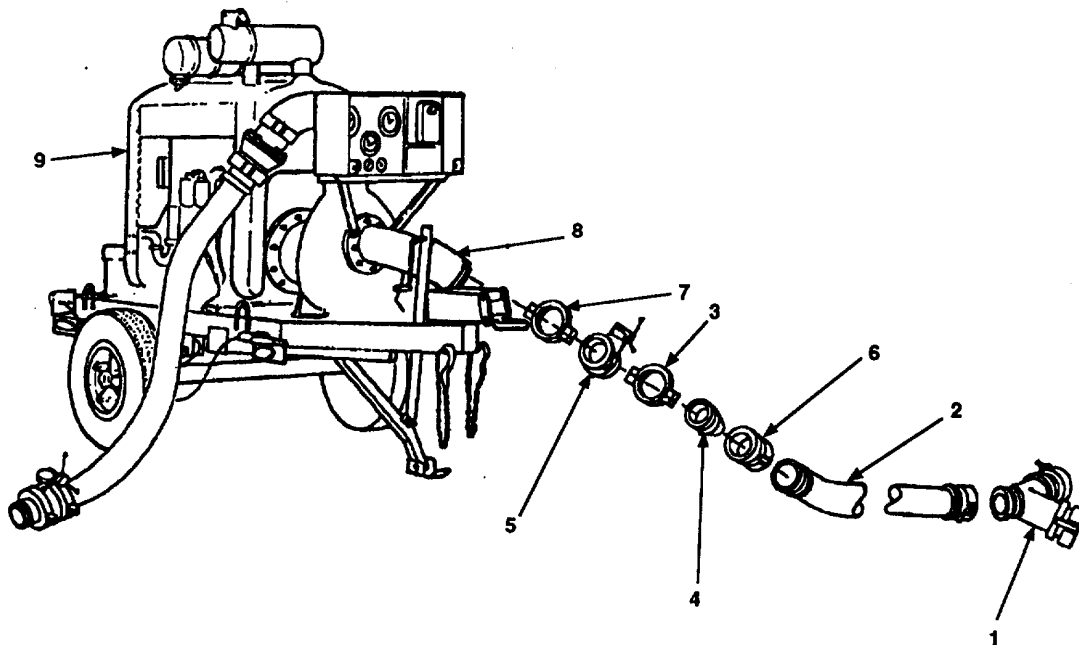


Figure 2-68. Disassembly of Lead Pumping Station (Suction Port).

NOTE

- Set aside all removed components for repacking.
 - Notify unit maintenance for removal of threaded fittings.
- a. Push cam arms on Y-connection reducer (Figure 2-68, 1) forward to open position. Remove Y-connection reducer (1) from water source.
 - b. Push cam arms on suction hose assembly (2) forward to open position. Remove Y-connection reducer (1) from hose assembly (2).
 - c. Disconnect additional suction hose assembly lengths (2) as required.
 - d. Remove grooved-end quick disconnect coupling clamp (3) (para 2.3.3.1) connecting coupling pipe fitting (4) to 6 inch butterfly valve assembly (5). Remove coupling pipe fitting (4) with attached coupling half (6).

2.8.3 Preparation for Movement of Lead Pumping Station. (Continued)

- e. Remove coupling half (6) from coupling pipe fitting (4).
- f. Remove grooved-end quick disconnect coupling clamp (7) (para 2.3.3.1) connecting 6 inch butterfly valve assembly (5) to suction port (8) on pumping assembly (9). Remove 6 inch butterfly valve assembly (5).
- g. Reference applicable technical manual and install plastic cap on suction port (8) of 600 GPM pumping assembly. Reference applicable technical manual for suction port location on 600 GPM pumping assemblies not shown.

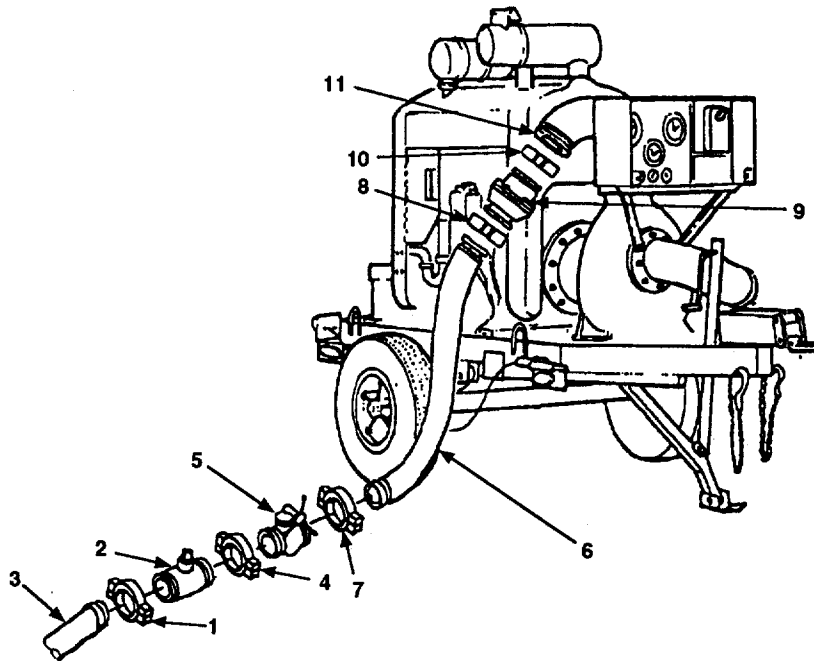


Figure 2-69. Disassembly of Lead Pumping Station (Discharge Port).

- h. Remove 6 inch grooved pipe coupling (Figure 2-69, 1) (para 2.3.2.1) connecting pressure relief valve assembly to (2) downline hoseline (3). Remove downline hoseline segment (3).
- i. Install 6 inch grooved pipe coupling (1) (para 2.3.2.2) on end of downline hoseline segment (3).
- j. Remove grooved-end quick disconnect coupling clamp (4) (para 2.3.3.1) connecting pressure relief valve assembly (2) to 6 inch butterfly valve assembly (5) on discharge hose assembly (6). Remove pressure relief valve assembly (2).
- k. Remove grooved-end quick disconnect coupling clamp (7) (para 2.3.3.1) connecting 6 inch butterfly valve assembly (5) to discharge hose assembly (6). Remove 6 inch butterfly valve assembly (5).
- l. Remove grooved-end quick disconnect coupling clamp (8) (para 2.3.3.1) connecting discharge hose assembly (6) to check valve (9). Remove discharge hose assembly (6).
- m. Install grooved-end quick disconnect coupling clamp (8) (para 2.3.3.2) on end of discharge hose assembly (6).

- n. Remove grooved-end quick disconnect coupling clamp (10) (para 2.3.3.1) connecting check valve (9) to discharge port (11) on 600 GPM pumping assembly, refer to applicable technical manual for location of discharge port on 600 GPM pumping assemblies not shown. Remove check valve (9).

2.8.4 Preparation for Movement of Boost Pumping Stations. This is a general procedure for moving boost pumping stations. For information pertaining to moving the 600 GPM pumping assemblies, reference applicable technical manuals.

2.8.4.1 Disassembly Requirements. Disassembly of each boost pumping station requires the tools and personnel referenced in paragraph 2.3.5.1. Pack the components listed in table 2-10 in the "PUMPING STATION" crate after removing them from the boost pumping station.

2.8.4.2 Disassembly Procedures.

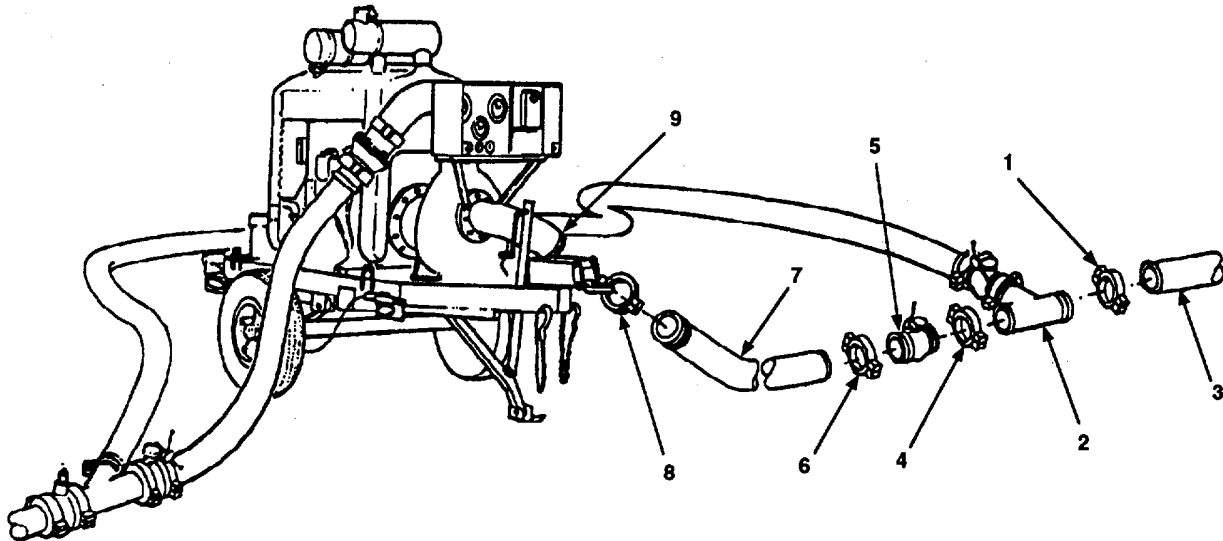


Figure 2-17. Disassembly of Boost Pumping Station (Suction Port).

NOTE

Set aside all removed components for repacking.

- a. Remove 6 inch grooved pipe coupling (Figure 2-70, 1) (para 2.3.2.1) connecting lateral grooved pipe fitting (2) to hoseline segment (3). Remove upline hoseline segment (3).
- b. Remove grooved-end quick disconnect coupling clamp (4) (para 2.3.3.1) connecting lateral grooved pipe fitting (2) to 6 inch butterfly valve (5).
- c. Remove grooved-end quick disconnect coupling clamp (6) (para 2.3.3.1) connecting 6 inch butterfly valve assembly (5) to discharge hose assembly (7). Remove 6 inch butterfly valve assembly (5).
- d. Remove 6 inch grooved pipe coupling (8) (para 2.3.2.1) connecting hose assembly (7) to suction port (9) on pumping assembly, refer to applicable technical manual for location of suction ports on 600 GPM pumping assemblies not shown. Remove hose assembly (7).
- e. Install 6 inch grooved pipe coupling (8) (para 2.3.2.2) on end of hose assembly (7).

2.8.4 Preparation for Movement of Boost Pumping Stations. (Continued)

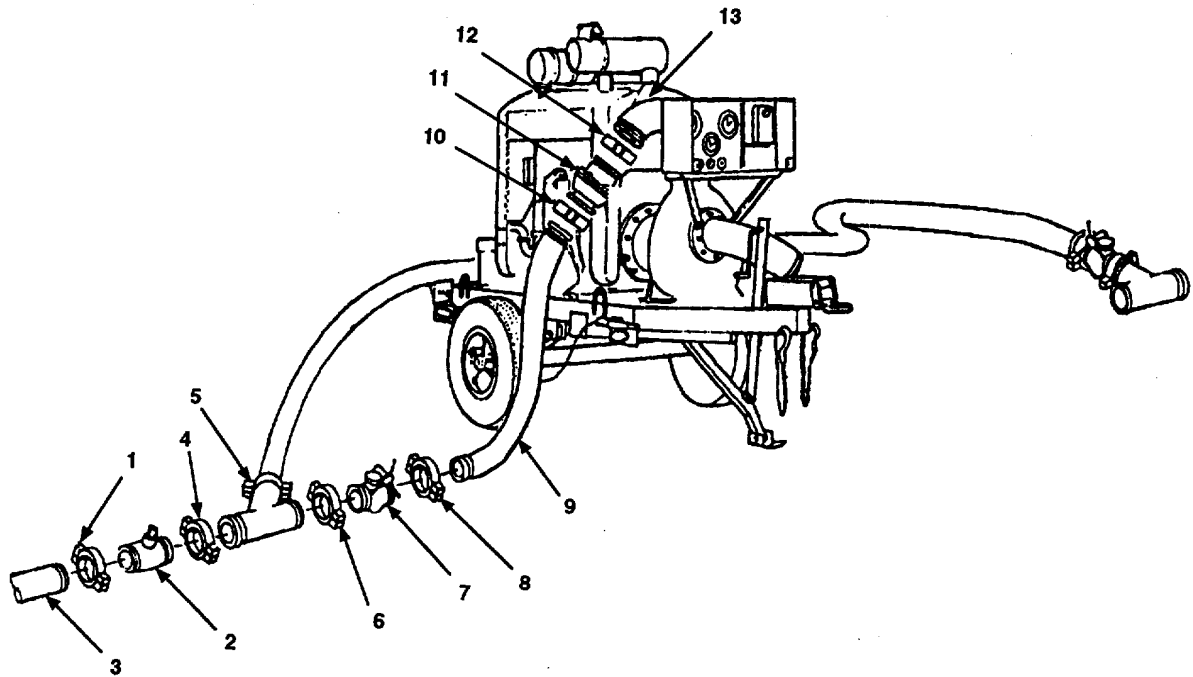


Figure 2-71. Disassembly of Boost Pump Station (Discharge Port).

- f. Remove 6 inch grooved pipe coupling (Figure 2-71, 1) (para 2.3.2.1) connecting pressure relief valve assembly (2) to downline hoseline segment (3). Remove downline hoseline segment (3).
- g. Install 6 inch grooved pipe coupling (1) (para 2.3.2.2) on end of downline hoseline segment (3).
- h. Remove grooved-end quick disconnect coupling clamp (4) (para 2.3.3.1) connecting pressure relief valve assembly (2) to lateral grooved pipe fitting (5). Remove pressure relief valve assembly (2).
- i. Remove grooved-end quick disconnect coupling clamp (6) (para 2.3.3.1) connecting lateral grooved pipe fitting (5) to 6 inch butterfly valve assembly (7).
- j. Remove grooved-end quick disconnect coupling clamp (8) (para 2.3.3.1) connecting 6 inch butterfly valve assembly (7) to hose assembly (9). Remove 6 inch butterfly valve assembly (7).
- k. Remove 6 inch grooved pipe coupling (10) (para 2.3.2.1) connecting hose assembly (9) to check valve (11). Remove hose assembly (9).
- l. Install 6 inch grooved pipe coupling (10) (para 2.3.2.2) on end of hose assembly (9).
- m. Remove 6 inch pipe coupling (12) (para 2.3.5.1) connecting check valve (11) to discharge port (13) on pumping assembly, refer to applicable technical manual for location of discharge ports on pumping assemblies not shown. Remove check valve (11).
- n. Remove grooved-end quick disconnect coupling clamp (Figure 2-72, 1) (para 2.3.3.1) connecting lateral grooved pipe fitting (2) to 6 inch butterfly valve assembly (3). Remove lateral grooved pipe fitting (2).

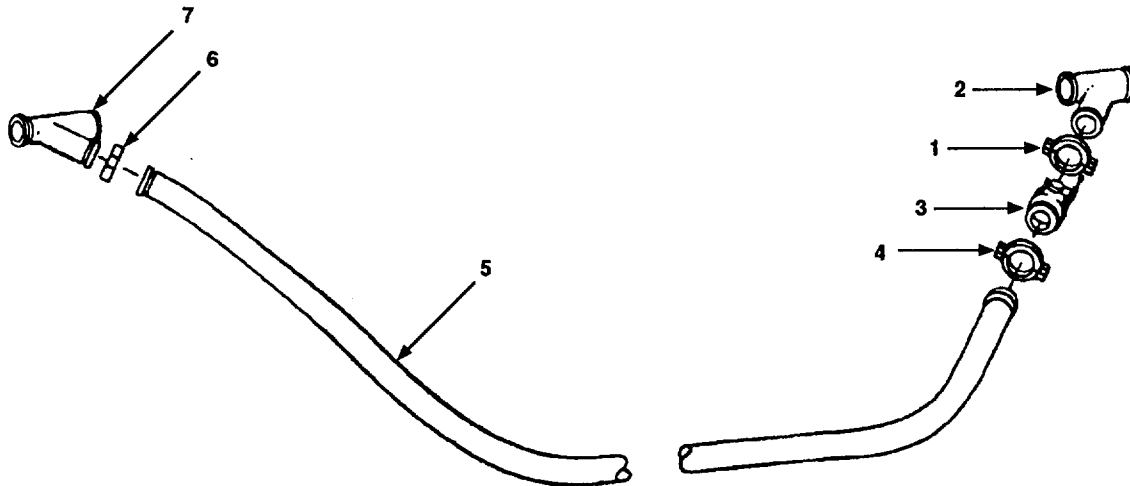


Figure 2-72. Disassembly of Bypass Hose.

- o. Remove grooved-end quick disconnect coupling clamp (4) (para 2.3.3.1) connecting 6 inch butterfly valve (3) to hose assembly (5). Remove 6 inch butterfly valve assembly (3).
- p. Install 6 inch grooved pipe coupling (4) (para 2.3.2.2) on end of hose assembly (5).
- q. Remove 6 inch grooved pipe coupling (6) (para 2.3.2.1) connecting hose assembly (5) to lateral grooved pipe fitting (7). Remove hose assembly (5) and lateral grooved pipe fitting (7).

2.8.5 Preparation for Movement of Storage Assemblies. This is a general procedure for the moving of storage assemblies. For additional information pertaining to moving the 20,000 gallon pillow tank, reference applicable technical manual.

2.8.5.1 Disassembly Requirements. Disassembly of a storage assembly requires the tools and personnel referenced in paragraph 2.3.6.1. Pack the components listed in table 2-11 in the "STORAGE ASSEMBLY" crate after removing them from the storage assembly.

2.8.5.2 Disassembly Procedures.

NOTE

Set aside all removed components for repacking.

- a. Remove grooved-end quick disconnect coupling clamp (1) (para 2.3.3.1) connecting reducing tee (2) to upline hoseline segment (3).
- b. Install grooved-end quick disconnect coupling clamp (1) (para 2.3.3.2) on end of hoseline segment (3).
- c. Remove 6 inch grooved pipe coupling (4) (para 2.3.2.1) connecting reducing tee (2) to downline hoseline segment (5).
- d. Remove grooved-end quick disconnect coupling clamp (6) (para 2.3.3.1) connecting coupling pipe fitting (7) to reducing tee (2).
- e. Remove reducing tee (2).
- f. Push cam arms on female quick disconnect coupling half (8) forward to open. Remove male coupling half (9) (with attached coupling pipe fitting (7)) from female quick-disconnect coupling half (8).

2.8.5 Preparation for Movement of Storage Assemblies. (Continued)

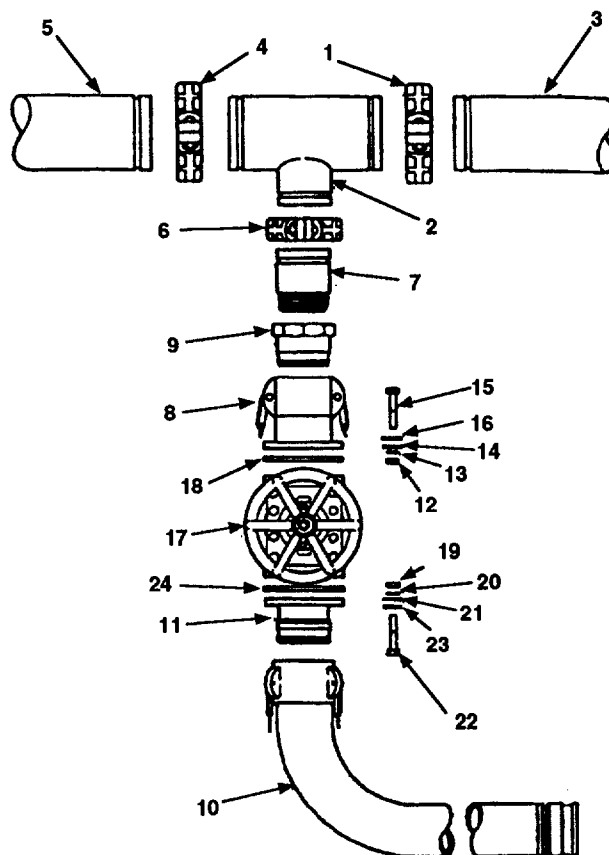


Figure 2-73. Disassembly of Storage Assembly Components.

- g. Unscrew male coupling half (9) and remove from coupling pipe fitting (7).
- h. Push cam arms on discharge hose assembly (10) forward to open. Remove valve assembly (24) from end of discharge hose (10).
- i. Remove eight nuts (12), lock washers (13), flat washers (14), and bolts (15) and flat washers (16). Remove female quick-disconnect coupling half (8) from 4 inch gate valve assembly (17).
- j. Carefully remove gasket (18).
- k. Remove eight nuts (19), lock washers (20), flat washers (21), bolts (22) and flat washers (23). Remove male flanged, quick-disconnect, coupling half (11) from 4 inch gate valve assembly (17).
- l. Carefully remove gasket (24).
- m. Disconnect first discharge hose assembly (Figure 2-74, 1) from female-to-female filler/discharge elbow (2) of 20,000 gallon storage tank (3).

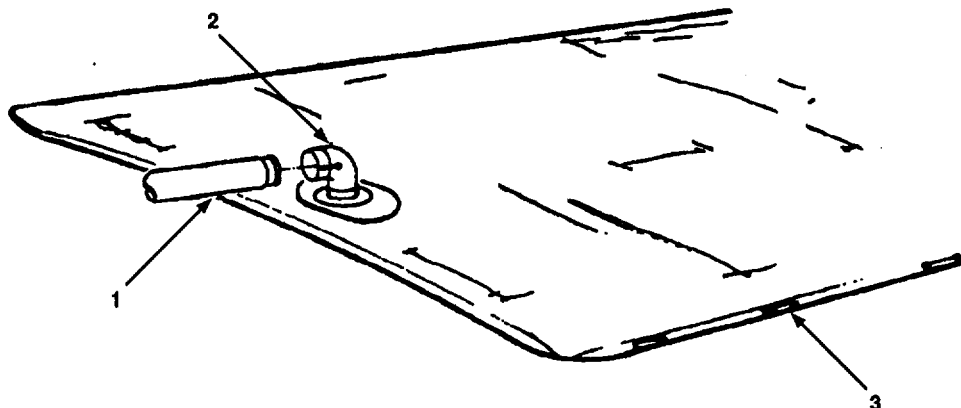


Figure 2-74. Disconnecting 20,000 Gallon Pillow Tank.

- n. Disconnect additional discharge hose assemblies as required to reach reducing tee/gate valve assembly.

2.8.6 Preparation for Movement of Distribution Points. This is a general procedure for moving the distribution points. For the preparation for movement, disassembly requirements, and disassembly procedures of the 125 GPM pumping assembly, reference applicable technical manual. For the preparation for movement, disassembly requirements, and disassembly of the model 1955-3 Hypochlorination unit reference applicable technical manual and for the model A-506131 Hypochlorination Unit reference applicable technical manual.

2.8.6.1 Disassembly Requirements. Disassembly of a distribution point requires the tools, personnel, and components referenced in paragraph 2.3.7.1. Pack the components listed in table 2-12 in the "DISTRIBUTION POINT" crate after removing them from the distribution points.

2.8.6.2 Disassembly Procedures.

WARNING

DANGEROUS CHEMICALS

- Calcium hypochlorite can cause injury if not handled properly. Heed safety measures below.
 - If calcium hypochlorite comes into contact with skin or eyes, flush right away with water. Seek medical help.
 - Mix only in accordance with directions for use.
 - DO NOT allow calcium hypochlorite to mix with any other materials. This can cause fire or hazardous gases.
- a. Locate packing crate marked "DISTRIBUTION POINT". Remove tubes of calcium hypochlorite (Item 2, Appendix E).
 - b. Dissolve one tube in each gallon of potable water used to make a cleaning solution.
 - c. Scrub inside of each 36 gallon drinking water storage bag (Figure 2-75, 1) with solution prepared in step b.
 - d. Rinse each drinking water storage bag (1) several times with potable water to get rid of all traces of cleaning solution prepared in step b. Do not use cleaning solution to rinse drinking water storage bags.

2.8.6 Preparation for Movement of Distribution Points (Continued)

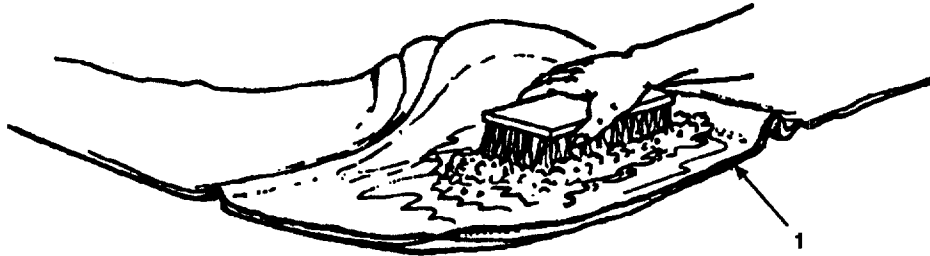


Figure 2-75. Cleaning of 36 Gallon Drinking Water Storage Bag.

- e. Dry drinking water storage bags (1) completely and set aside.

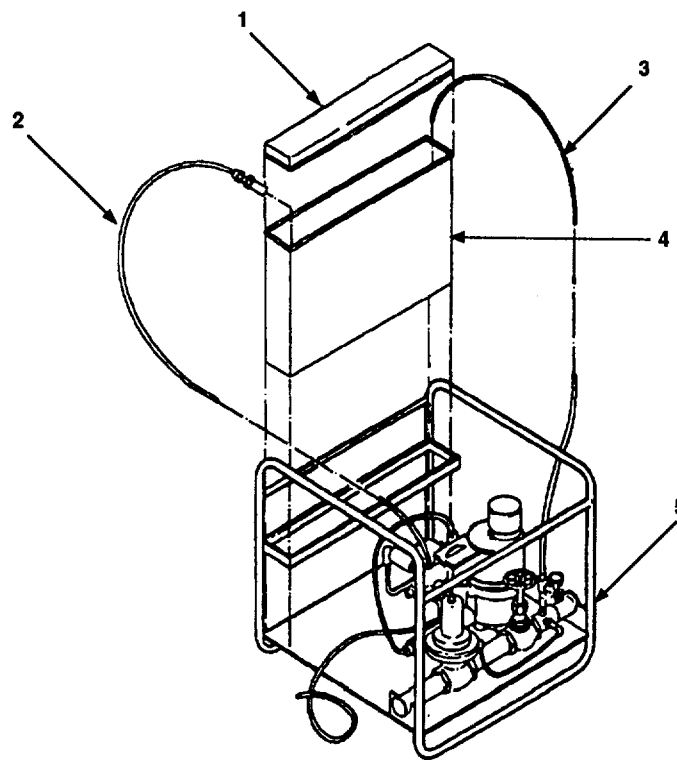


Figure 2-76. Disassembly of Model 1955-1 Hypochlorination Unit.

NOTE

Perform step f if model 1955-1 hypochlorination unit was used with distribution point.

- f. Following steps below, clean plastic reservoir on 1955-1 hypochlorination unit:

- (1) Remove reservoir cover (Figure 2-76, 1).
- (2) Remove suction hose (2) and reservoir fill hose (3) from reservoir (4).
- (3) Remove and empty reservoir (4) on hypochlorination unit (5). Rinse reservoir (4) and install on hypochlorination unit (5).

- (4) Place suction hose (2) and reservoir fill hose (3). Install cover (1) on reservoir (4).
- g. Refer to applicable technical manual and clean plastic reservoir if the Hypochlorination Unit, model A-506131 was used with the distribution point.
- h. Refer to applicable technical manual and clean plastic reservoir if Hypochlorination Unit, model 1955-3 was used with the distribution point.

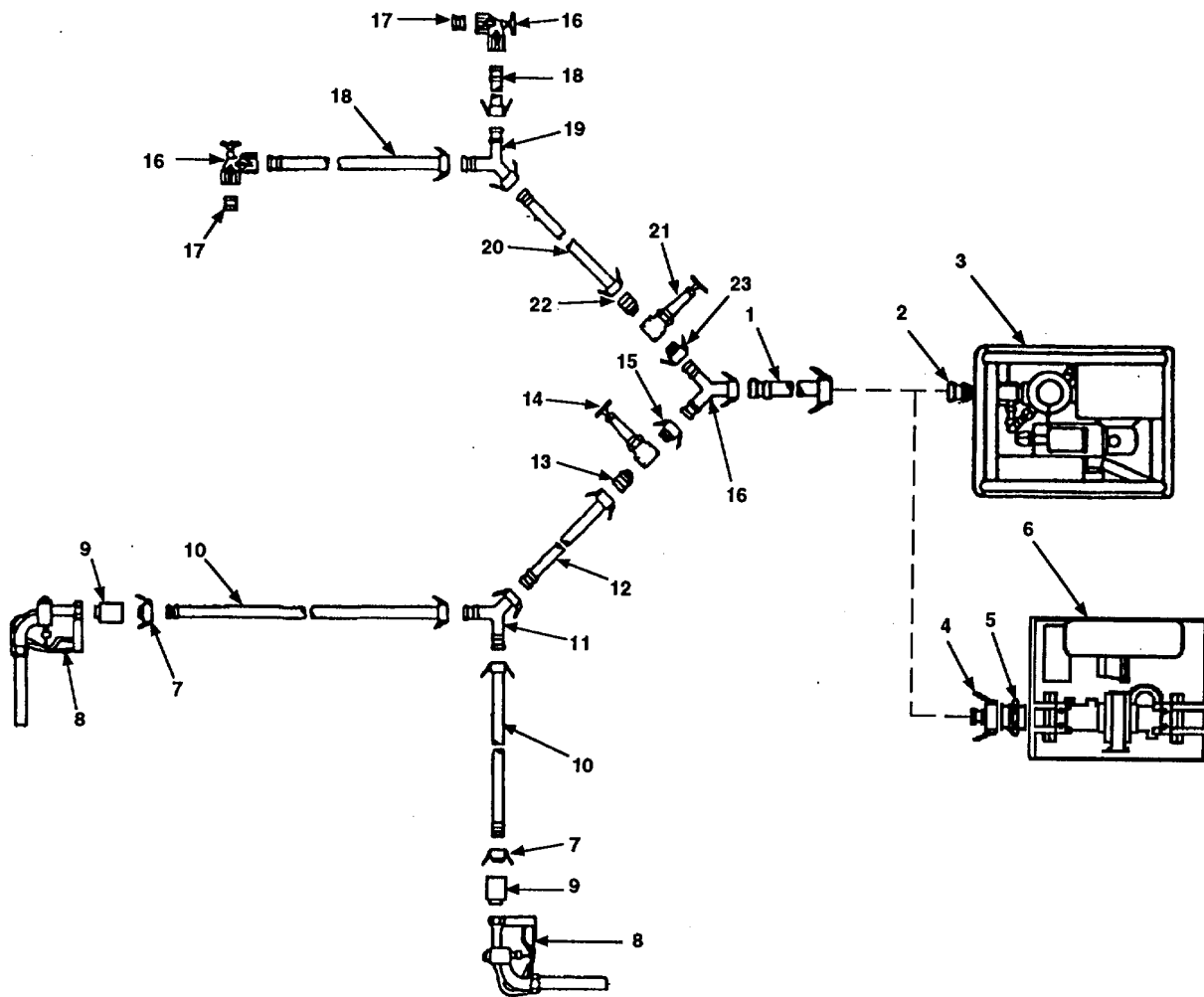


Figure 2-77. Disassembly of Distribution Point.

NOTE

If disconnecting Hypochlorination Unit model 1955-1 or model A-506131 perform steps i and j. If disconnecting Hypochlorination Unit model 1955-3 perform steps k through m.

- i. Push cam arms on discharge hose assembly (Figure 2-77, 1) forward to open. Remove hose assembly (1) attached to male quick-disconnect coupling half (2) on hypochlorination unit (3) outlet port.

2.8.6 Preparation for Movement of Distribution Points. (Continued)

- j. Unscrew and remove male quick-disconnect coupling half (2) from hypochlorination unit (3) outlet port.
- k. Push cam arms on hose assembly (1) forward to open. Remove hose assembly (1) attached to reducer (4).
- l. Push cam arms on reducer (4) forward to open. Remove reducer (4) from male coupling half (5).
- m. Remove male coupling half (5) from hypochlorination unit (6).
- n. Start 125 GPM pumping assembly.

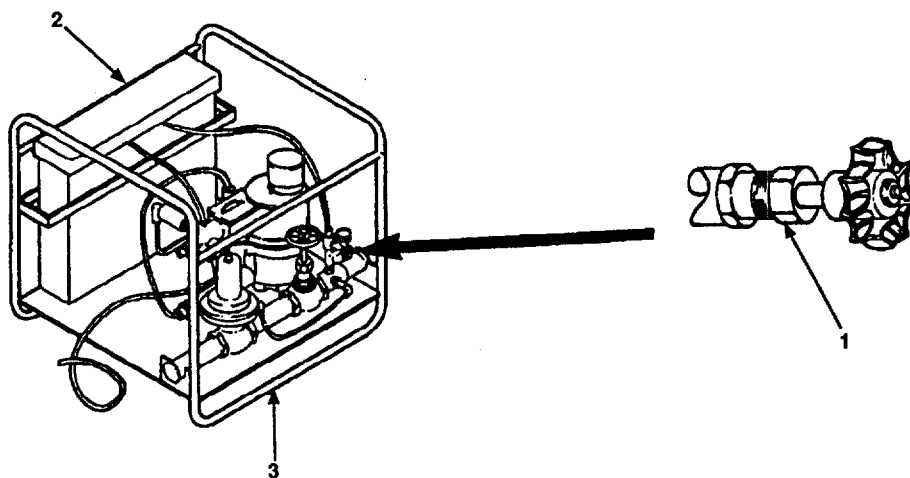


Figure 2-78. Flushing of Hypochlorination Unit (Model 1955-1 Shown).

- o. Open hypochlorination unit reservoir fill valve (Figure 2-78, 1). Fill reservoir (2) with water. When reservoir (2) is full, close reservoir fill valve (1) of hypochlorination unit (3).
- p. If model 1955-1 is used, perform steps c through i of paragraph 2.5.5.4. For disassembly of hypochlorination unit model 1955-3 and model A-506131 reference applicable technical manual.
- q. Allow hypochlorination unit to operate for 10 minutes to flush solution from hypochlorination unit parts and tubes. At the same time, continue to disconnect hoseline network.
- r. Push cam arms of two reducers (Figure 2-77, 7) forward to open. Remove two nozzles (8) with attached hose swivels (9) and reducers (7) from ends of hose assemblies (10).
- s. Unscrew and remove two reducers (7) from ends of hose swivels (9).
- t. Unscrew and remove two hose swivels (9) from ends of nozzles (8).
- u. Push cam arms on hose assemblies (10) forward to open. Remove hose assemblies (10) from end of Y-connection (11).
- v. Push cam arms on Y-connection (11) forward to open. Remove Y-connection (11) from end of hose assembly (12).
- w. Push cam arms on discharge hose (12) forward to open. Remove hose from male quick-disconnect coupling half (13) attached to 2 inch gate valve (14).

- x. Push cam arms on female quick-disconnect coupling half (15) forward to open. Remove 2 inch gate valve (14) with attached male quick-disconnect coupling half (13) and female quick-disconnect coupling half (15) from end of Y- connection (16).
- y. Remove male quick-disconnect (13) and female quick-disconnect (15) coupling halves from ends of 2 inch gate valve (14).
- z. Push both sets of cam arms on elbow valves (16) forward to open. Remove two dust plugs (17) from ends of elbow valves (16).
- aa. Remove elbow valves (16) from ends of two hose assemblies (18).
- ab. Repeat steps u through y to disconnect hose assemblies (18), Y-connection (19), hose assembly (20), 2 inch gate valve (21), male quick-disconnect (22) and female quick-disconnect (23) coupling halves.
- ac. Push cam arms on Y-connection (16) forward to open. Remove Y-connection (16) from end of hose assembly (1).
- ad. Refer to applicable technical manual and shut down 125 GPM pumping assembly.

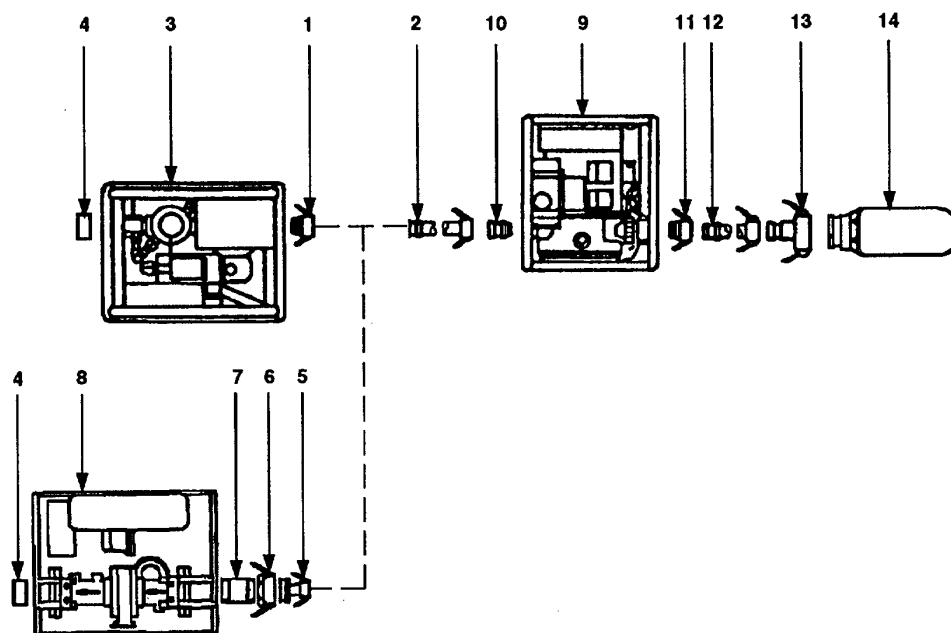


Figure 2-79. Removal of 125 GPM Pumping Assembly and Hypochlorination Unit.

NOTE

If disconnecting hypochlorination unit model 1955-1 or model A-506131 perform steps ae and af. If disconnecting hypochlorination unit model 1955-3 perform steps ag through aj.

- ae. Push cam arms on inlet port female quick-disconnect coupling half (Figure 2-79, 1) forward to open. Remove hose assembly (2) from female quick-disconnect coupling half (1) on inlet port of hypochlorination unit (3).
- af. Remove female quick-disconnect coupling half (1) from hypochlorination unit (3) inlet port.

2.8.6 Preparation for Movement of Distribution Points. (Continued)

- ag. Push cam arms on inlet port reducer (5) forward to open. Remove hose assembly (2) from reducer (5).
- ah. Push cam arms on female quick-disconnect coupling half (6) forward to open." "Remove reducer (5) from female quick-disconnect coupling half (6).
- ai. Remove female quick-disconnect coupling half (6) from nipple (7).
- aj. Remove nipple (7) from hypochlorination unit (8).
- ak. Install plastic dust caps (4) on hypochlorination unit (3) inlet and outlet" "ports.
- al. Refer to applicable technical manual and restart 125 GPM pumping assembly (9).
- am. Drain storage tank as much as possible. When storage tank is drained, refer" "to applicable technical manual and shut down 125 GPM pumping assembly (9)." "Continue disconnecting distribution point.
- an. Push cam arms on hose assembly (2) forward to open. Remove hose from male" "quick-disconnect coupling half (10) on outlet port of 125 GPM pumping assembly" "(9).
- ao. Unscrew and remove male quick-disconnect coupling half (10) from 125 GPM" "pumping assembly (9) outlet port.
- ap. Push cam arms on inlet female quick-disconnect coupling half (11) forward to" "open. Remove end of hose assembly (12) from female quick-disconnect coupling" "half (11) on inlet port of 125 GPM pumping assembly (9).
- aq. Unscrew and remove female quick-disconnect coupling half (11) from 125 GPM" "pumping assembly (10) inlet port.
- ar. Push cam arms on hose assembly (12) forward to open. Remove hose (12) from 2" "inch end of reducer (13) attached to filler/discharge elbow (14) on 20,000" "gallon pillow tank.
- as. Push cam arms on reducer (13) forward to open. Remove reducer (13) from elbow" "(14) on 20,000 gallon pillow tank.

SECTION IV. OPERATION UNDER UNUSUAL CONDITIONS**2.9 OPERATION IN UNUSUAL WEATHER.**

The instructions for operation under unusual conditions are provided in paragraphs 2.9.1 through 2.9.5.

2.9.1 600 GPM Pumping Assemblies. For the operation of 600 GPM pumping assemblies under unusual environmental/weather conditions, reference applicable technical manual.

2.9.2 125 GPM Pumping Assembly. For the operation of 125 GPM pumping assembly under unusual environmental/weather conditions, reference applicable technical manual.

2.9.3 Hypochlorination Units, Models 1955-3 and A-506131. For the operation of" "hypochlorination units models 1955-3 and A-506131 under unusual environmental/weather conditions, reference applicable technical manual.

2.9.4 20,000 Gallon Pillow Tank. For the operation of 20,000 gallon pillow tank under unusual environmental/weather conditions, reference applicable technical manual.

2.9.5 Other TWDS Components. The following paragraphs will provide operating procedures for operating the remaining TWDS components under unusual environmental/weather conditions.

2.9.5.1 Operation in Extreme Heat. Pressure-Reducing Valve Assembly. Cover unit with moistened burlap, tarpaulin, or suitable cover to shade it from sun.

2.9.5.2 Operation in Cold Weather. The TWDS is not intended for use at temperatures below 32° F (0°C).

2.9.5.3 Operation in Salt Water Area. Pressure-Reducing Valve Assembly. Notify organizational maintenance if rust or aluminum oxide formations are present.

2.9.5.4 Operation in Dusty or Sandy Conditions. Hypochlorination Units. Protect unit from sand or dust as much as possible. Be careful when mixing chlorine solution to prevent introduction of sand or grit in solution (para 2.5.5.4).

2.9.5.5 Operation in High Winds. 10-Mile Hoseline Segment. Pack hoseline as soon as possible (para 2.5.1).

2.10 NUCLEAR, BIOLOGICAL, AND CHEMICAL (NBC) DECONTAMINATION.

Refer to FM 3-3, FM 3-4, FM 3-4-1, FM 3-5, FM 3-6, and FM 3-8 for decontamination procedures.

2.11 FORDING.

Reference applicable technical manual for fording procedures on the vehicle used to transport TWDS components. Reference the applicable technical manual for fording procedures for the 600 GPM pumping assemblies and the model 1955-3 and model A-506131 hypochlorination units. Reference the applicable technical manual for fording procedures for the 125 GPM pumping assembly.

2.12 EMERGENCY PROCEDURES.

2.12.1 General. Performance of the entire TWDS depends on continuous operation of each major component. In most cases, when part of the equipment fails, the entire system must be shut down. Procedures for partial operation are limited. The only emergency procedures possible are listed below. In all other situations, the entire TWDS must be shut down until the problem is corrected.

2.12.2 Failure of Boost Pumping Station.

CAUTION

- Do not attempt to operate other pumping stations when one unit fails.
 - The bypass hose assembly is used only to keep downline pumps primed. Enough pressure will not exist to operate downline pumps, even at a partial rate.
- a. Refer to the applicable technical manual and shut off engine.
 - b. Open butterfly valve in bypass line.
 - c. Close butterfly valves in suction and discharge lines to and from 600 gpm pumping assembly to shut off water flow through malfunctioning pump.
 - d. Notify operators at other pumping stations of equipment failure.
 - e. Refer to the applicable technical manual and decrease lead pump operation so that discharge rate will be enough to keep downline pumps primed.

2.12.2 Failure of Boost Pumping Station. (Continued)

- f. Boost pumps (operating in electric/automatic mode) should decrease to idle automatically. Operators at boost pumping stations should make certain their units have adjusted properly. Operators must also monitor readings on pressure gages. Reference the applicable technical manual and immediately shut down 600 GPM pumping assemblies that fail to remain primed.
- g. Close gate valves connected to storage assemblies.
- h. Distribution points continue to operate as long as enough water remains in storage tanks. When water in storage tanks drops to inoperable level, shut down operation of distribution points (para 2.5.5). Refer to the applicable technical manual and shut down engine on 125 GPM pumping assembly (para 2.5.5.2).

2.12.3 Failure of Storage Assembly. If storage assembly fails, operation is possible ONLY under the following conditions:

- (1) Two storage assemblies are in use, and
- (2) The unaffected storage assembly is being used with a distribution point. To temporarily adapt operation, proceed as follows:
 - a. Notify operators at other stations of equipment failure. 600 GPM pumping assemblies may require adjustment, if necessary refer to applicable technical manual and adjust operation of 600 GPM pumping assemblies accordingly.
 - b. Close gate valve connected to defective storage tank (para 2.5.4).
 - c. If distribution point is being used with defective storage tank, shut down distribution point (para 2.5.5). Refer to the applicable technical manual and shut down engine on 125 GPM pumping assembly.

2.12.4 Failure of Distribution Point. If a distribution point fails, TWDS operation is possible ONLY if two distribution points are in use. To temporarily adapt TWDS operation, proceed as follows:

- a. Notify operators at other stations of equipment failure. 600 GPM pumping assemblies may require adjustment, if necessary refer to the applicable technical manual and adjust operation of 600 GPM pumping assemblies accordingly.
- b. Close gate valve connected to 20,000 gallon pillow tank in use with defective distribution point (para 2.5.5).
- c. Shut down operation of defective distribution point (para 2.5.5). Refer to the applicable technical manual and shut down engine on 125 GPM pumping assembly (2.5.5.2).

CHAPTER 3
OPERATOR MAINTENANCE INSTRUCTIONS

Subject Index	Page
Section I. LUBRICATION INSTRUCTIONS	3-1
3.1 Lubrication.....	3-1
Section II. OPERATOR TROUBLESHOOTING PROCEDURES	3-1
3.2 Troubleshooting.....	3-1
Section III. OPERATOR MAINTENANCE PROCEDURES	3-5
3.3 Pumping Station Maintenance.....	3-5
3.4 10-Mile Hoseline Segment Maintenance.....	3-12
3.5 Storage Assembly Maintenance.....	3-12
3.6 125 GPM Pumping Assembly Maintenance.....	3-12

SECTION I. LUBRICATION INSTRUCTIONS

3.1 LUBRICATION.

There are no general lubrication procedures required for the TWDS. Refer to applicable technical manual for lubrication procedures for 600 GPM pumping assemblies, 125 GPM pumping assembly, and hypochlorination units, models A-506131 and 1955-3.

SECTION II. OPERATOR TROUBLESHOOTING PROCEDURES

3.2 TROUBLESHOOTING.

The malfunction index lists faults that may be observed by the operator. The faults are then cross-referenced to the troubleshooting Table 3-1. Table 3-1 contains information useful in diagnosing and correcting unsatisfactory conditions which may be encountered during operation or maintenance of the TWDS. Use the malfunction index to locate specific troubleshooting procedures contained in Table 3-1. After locating the troubleshooting procedure, perform the test/inspections and corrective actions in the order listed. The malfunction index and Table 3-1 cannot list all of the malfunctions that may occur, all the test and inspections needed to find the fault, or all the corrective actions needed to correct the fault. If the equipment malfunction is not listed or actions listed do not correct the fault, notify your supervisor. Refer to applicable technical manual for troubleshooting procedures for 600 GPM pumping assemblies, 125 GPM pumping assembly, and hypochlorination units, models A-506131 and 1955-3.

OPERATOR MALFUNCTION INDEX

	Malfunction Number in Table 3-1
20,000 Gallon Pillow Tank is not being filled	1
Hypochlorination Unit, Model 1955-1 is not injecting solution into water.....	2
No discharge of water at manual disbursing stations.....	3
No discharge of water at pressure reducing valve.....	4
Pressure Relief Valve activates.....	5

Table 3-1. Operator Troubleshooting Table.

**MALFUNCTION
TEST OR INSPECTION
CORRECTIVE ACTION**

1. 20,000 GALLON PILLOW TANK IS NOT BEING FILLED.

Step 1. Check 4-inch gate valve to see if it is closed or damaged.

- a. Open 4-inch gate valve.
- b. Notify supervisor if 4-inch gate valve is damaged or Class III leak is present.

Table 3-1. Operator Troubleshooting Table. (Continued)

MALFUNCTION
TEST OR INSPECTION
CORRECTIVE ACTION

- Step 2. Check to see if valve on drain assembly is open or damaged.
- Close valve.
 - Refer to applicable technical manual for 20,000 gallon pillow tank and replace damaged valve.
- Step 3. Check to see if tank fabric is punctured, torn, or damaged.
- Refer to applicable technical manual and repair damaged 20,000 gallon pillow tank.
- Step 4. Check hose assembly for leaks.
- Close 4-inch gate valve, refer to paragraph 2.3.6.2 disconnect and reconnect hose if hose connections have a Class III leak, open 4-inch gate valve.
 - If hose assembly is damaged, notify unit maintenance.
- Step 5. Check to see if pressure-reducing valve assembly is damaged.
- Notify unit maintenance if pressure reducing valve assembly is damaged.

2. HYPOCHLORINATION UNIT, MODEL 1955-1 IS NOT INJECTING SOLUTION INTO WATER.

- Step 1. Check to see if range adjusting valve is closed or damaged.
- Open range adjusting valve.
 - Notify supervisor if range adjusting valve is damaged or has a Class III leak.
- Step 2. Check to see if solution reservoir is empty or leaking.
- Refer to paragraph 2.5.5.4 and add hypochlorite solution.
 - Notify supervisor if solution reservoir is damaged or has a Class III leak.
- Step 3. Check to see if foot valve is clogged or damaged.
- Clear clog from clogged foot valve.
 - Notify supervisor if foot valve is damaged.
- Step 4. Check hypochlorite feeder.
- Refer to paragraph 2.5.5.4 steps g, h, i and prime hypochlorite feeder.

3. NO DISCHARGE OF WATER AT MANUAL DISBURSING STATION.

- Step 1. Check to see if 125 GPM pumping assembly is working.
- Refer to applicable technical manual and troubleshoot 125 GPM pumping assembly.
- Step 2. Check to see if 2-inch gate valves are closed or leaking.
- Open 2-inch gate valve.
 - Notify supervisor if 2-inch gate valve is damaged or has a Class III leak.

Table 3-1. Operator Troubleshooting Table. (Continued)

MALFUNCTION	TEST OR INSPECTION	CORRECTIVE ACTION
3. NO DISCHARGE OF WATER AT MANUAL DISBURSING STATION. (CONTINUED)		
	Step 3. Check 2 inch and 4 inch hoseline sections for loose connections or leaks.	<ul style="list-style-type: none"> a. Refer to paragraph 2.3.7 and reconnect loose 2 inch hoseline connection or refer to paragraph 2.3.7 and reconnect loose 4 inch hoseline connection. b. Notify supervisor if 2 inch or 4 inch hoseline is damaged or has a Class III leak.
	Step 4. Check nozzles and elbow valve assemblies for damage or defective parts.	<ul style="list-style-type: none"> a. If damaged or defective parts are found, notify unit maintenance.
	Step 5. Check hypochlorination unit adjustment range to ensure that flow is at 14 gpm.	<ul style="list-style-type: none"> a. If 14 gpm flow rate can not be obtained, notify unit maintenance.
4. NO DISCHARGE OF WATER AT PRESSURE REDUCING VALVE.		
	Step 1. Check that isolation cock valves are open.	<ul style="list-style-type: none"> a. If not, fully open isolation cock valves. b. If no discharge of water, go to step 2.
	Step 2. Ensure pressure reducing valve is correctly installed.	<ul style="list-style-type: none"> a. If water still does not flow and pressure reducing valve is correctly installed, notify unit maintenance.
5. PRESSURE RELIEF VALVE ACTIVATES.		
	Step 1. Check for obstructions and closed butterfly valves downline.	<ul style="list-style-type: none"> a. Clear obstructions. b. Open butterfly valves.
	Step 2. Check for proper installation of pressure reducing valve.	<ul style="list-style-type: none"> a. Reposition pressure reducing valve if required.
	Step 3. Check for malfunctioning pressure reducing valve.	<ul style="list-style-type: none"> a. Check that, isolation check valves are open. b. If still malfunctioning, notify unit maintenance.
	Step 4. Refer to technical manual for 600 gpm pumping assemblies and ensure 600 gpm pumping assemblies are operating properly.	<ul style="list-style-type: none"> a. If 600 gpm pumping assemblies are not operating properly, refer to proper technical manual and troubleshoot 600 gpm pumping assemblies.
	Step 5. Install new pressure relief valve.	

SECTION III. OPERATOR MAINTENANCE PROCEDURES

3.3 PUMPING STATION MAINTENANCE.

Refer to applicable technical manual for operator maintenance procedures for the 600 GPM pumping assemblies.

3.4 10-MILE HOSELINE SEGMENT MAINTENANCE .

3.4.1 6 Inch Hose Assembly Repair.

This task covers:

3.4.1.1 Male Quick-Disconnect
Coupling Half Repair

3.4.1.2 Double-Ended Adapter Repair

INITIAL SETUP

Tools

Tools required for repair of 6 inch hose assemblies are contained in Hoseline Repair Kit, Section II, Item 124, Appendix C

Materials/Parts

Rags, Item 7, Appendix E

Items to be used for repair of 6 inch hose assemblies are contained in Hoseline Repair Kit, Section II, Item 124, Appendix C.

Equipment Conditions

Pumping Stations shutdown, refer to applicable technical manual.

General Safety Instructions

Ensure pumping stations are shutdown to eliminate pressure build up in hoseline.

Do not work on equipment without following standard safety precautions.

3.4.1.1 Male Quick-Disconnect Coupling Half Repair .

WARNING

Ensure pumping assemblies are shut down before performing this procedure. Failure to shut down pumping assemblies will result in excessive water pressure in hoseline which may rupture causing personal and personnel injury.

NOTE

This procedure is applicable to 6 inch by 10, 20, and 75 foot hose assemblies and 6 inch by 500 foot hoseline segment.

- a. Install hose clamps (Figure 3-1, 1) 3 feet up-line and downline from hose section (2) to be removed.

3.4.1 6 Inch Hose Assembly Repair. (Continued)

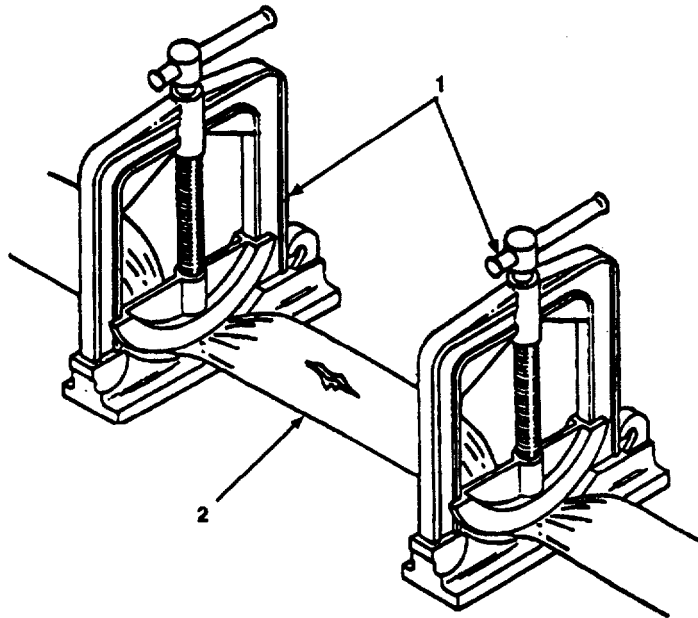


Figure 3-1. Hose Clamp Installation.

- b. Tighten hose clamps (1) until hose (2) is pinched closed.

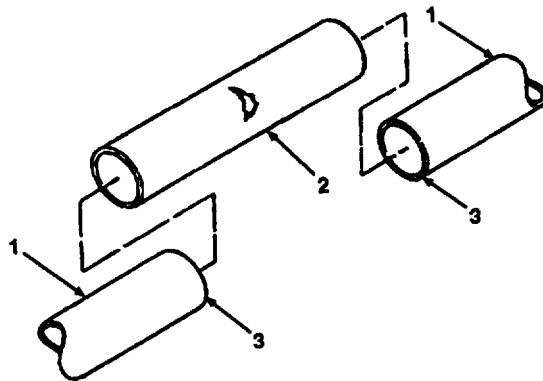


Figure 3-2. Damaged Hose Section Removal.

NOTE

Always mark, score, and cut hose squarely. Do not leave ragged or uneven edges.

- c. Cut both sides of hose (Figure 3-2, 1), 6 inches from leak.
- d. Remove damaged section of hose (2).
- e. Inspect inside of hose ends (3) for further damage.
- f. Cut hose (1) back again, as required, to reach an undamaged area.

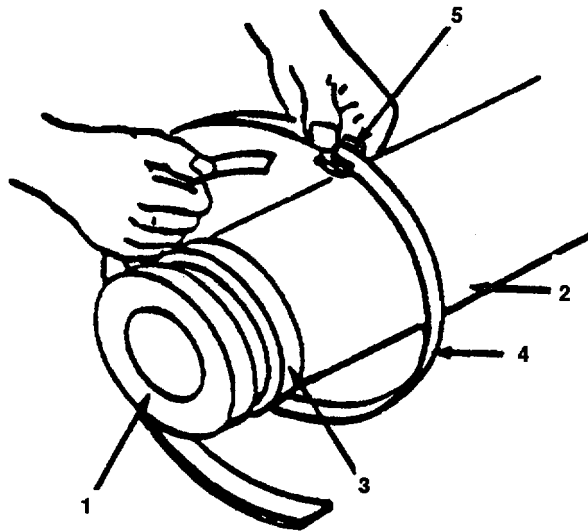


Figure 3-3. Male Quick-Disconnect Coupling Half and Banding Installation.

- g. Drain hose ends (3) and wipe dry.
- h. Insert male-end of quick-disconnect coupling half (Figure 3-3, 1) into hose end (2), until shoulder (3) is flush with hose end (2).
- i. Cut strapping to sufficient length to accommodate double wrap around hose and have an additional 10 inches of strapping.
- j. Bend strapping approximately 2 inches from either end.
- k. Install buckle on opposite end of strapping. Slide buckle to bend ensuring ears of buckle are up and in bend of strapping.
- l. Place both ends of strapping (4) through buckle (5).

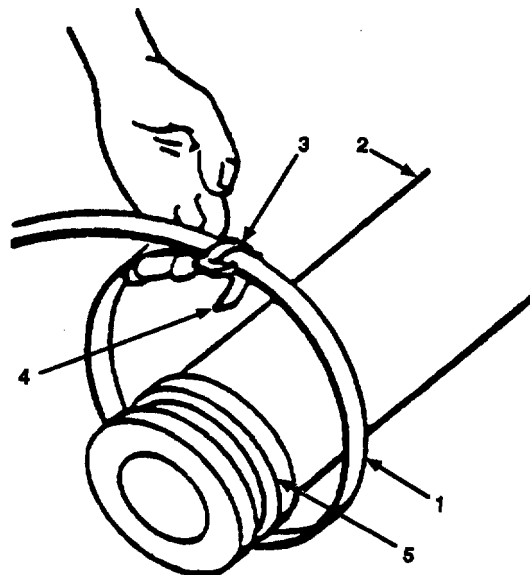


Figure 3-4. Strapping Preparation.

3.4.1 6 Inch Hose Assembly Repair. (Continued)

NOTE

Double bands must be used to secure adapters on hoseline lengths.

- m. Continue long end of strapping (Figure 3-4, 1) around hose (2) and through buckle (3) once more, forming a double band.
- n. Position buckle (3) so that it is on top of hose (2).

CAUTION

To avoid cutting or weakening hose wall when bands are tightened, install bands between quick-disconnect coupling halves.

- o. Position strapping (1) in groove farthest from adapter (5).

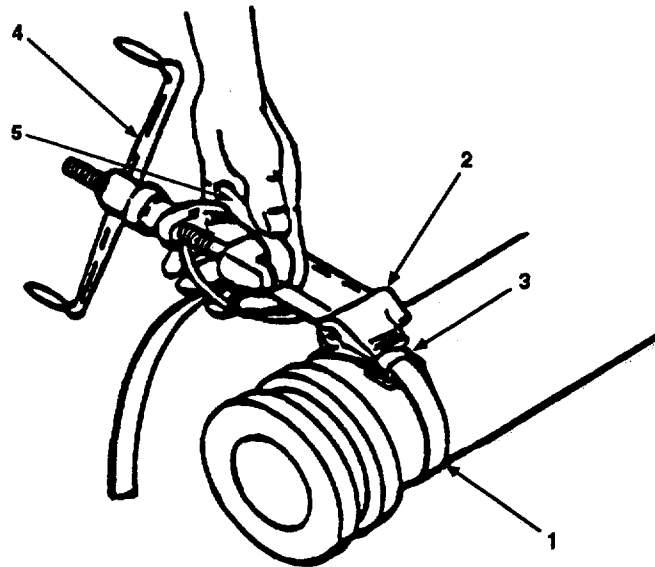


Figure 3-5. Preparing Banding Tool for Use.

- p. Install strapping (Figure 3-5, 1) through open slot of banding tool nose (2). Ensure ears of buckle (3) are facing away from banding tool (4) and band gripper lever (5) is facing up.

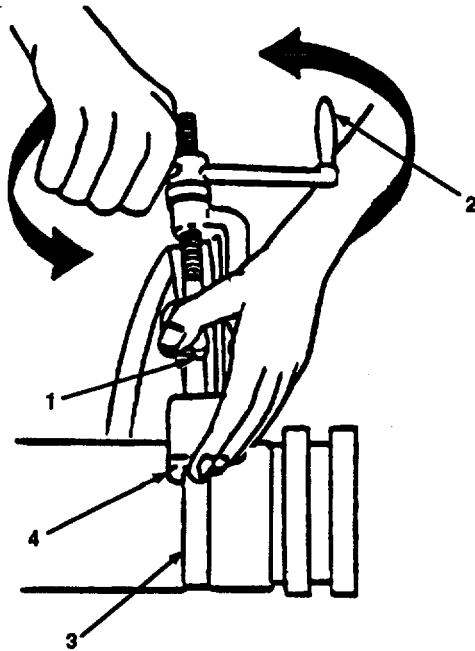


Figure 3-6. Tightening Strapping.

NOTE

After tension is created, it is not necessary to hold band gripper lever, since it locks itself under tension.

- q. With thumb on band gripper lever (Figure 3-6, 1), apply tension by turning banding tool handle (2) clockwise.
- r. Continue to turn banding tool handle (2) clockwise until strapping (3) stops moving, stop turning banding tool handle (2).

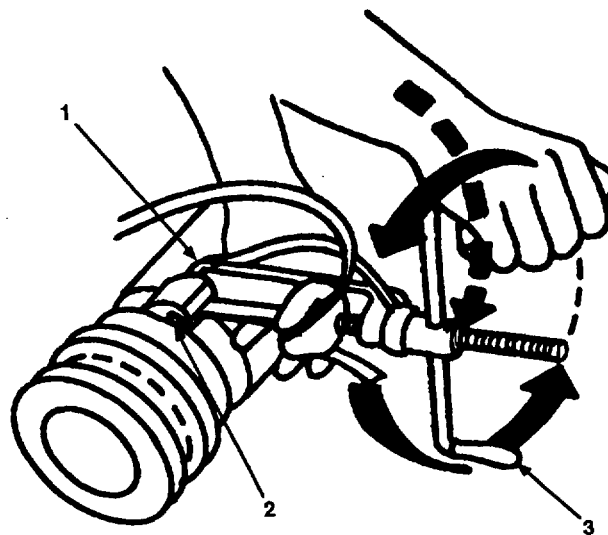


Figure 3-7. Rolling of Banding Tool.

3.4.1 6 Inch Hose Assembly Repair. (Continued)

NOTE

To prevent breaking strapping, release tension by turning banding tool handle counterclockwise while rolling banding tool over buckle.

- s. Roll banding tool (Figure 3-7, 1) over buckle (2), releasing tension by turning banding tool handle (3) clockwise throughout entire course of roll.

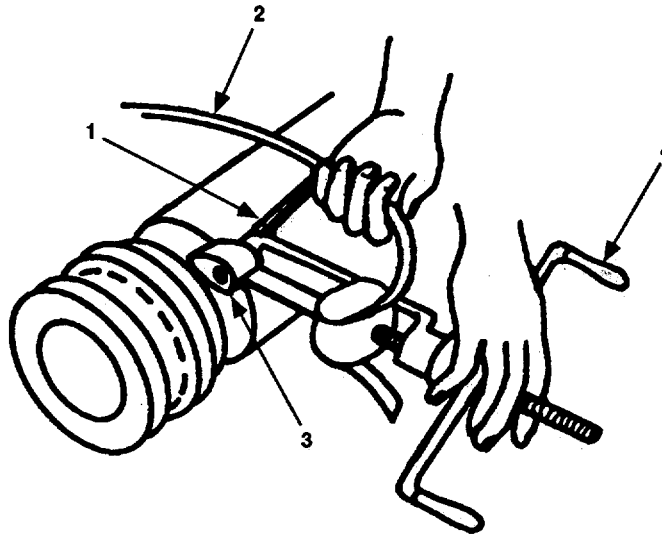


Figure 3-8. Removing Banding Tool.

- t. Pull cutting handle (Figure 3-8, 1), cut strapping (2) and remove banding tool (4).

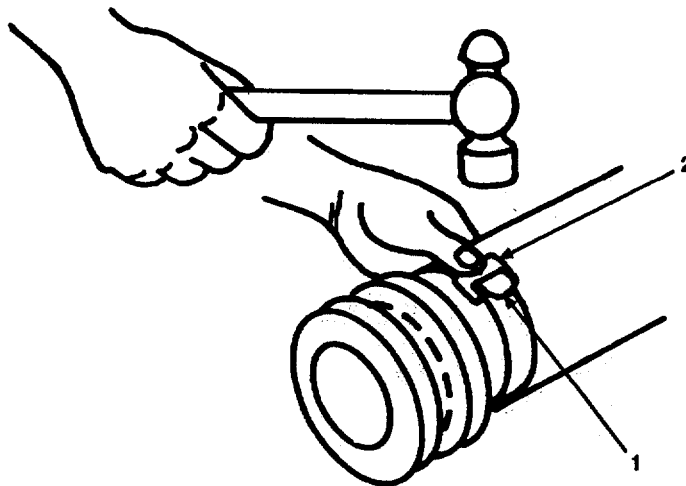


Figure 3-9. Securing Buckle and Strapping.

- u. Clinch strapping stub (Figure 3-9, 1) by hammering down stub, then ears of buckle (2).

3.4.1 6 Inch Hose Assembly Repair. (Continued)

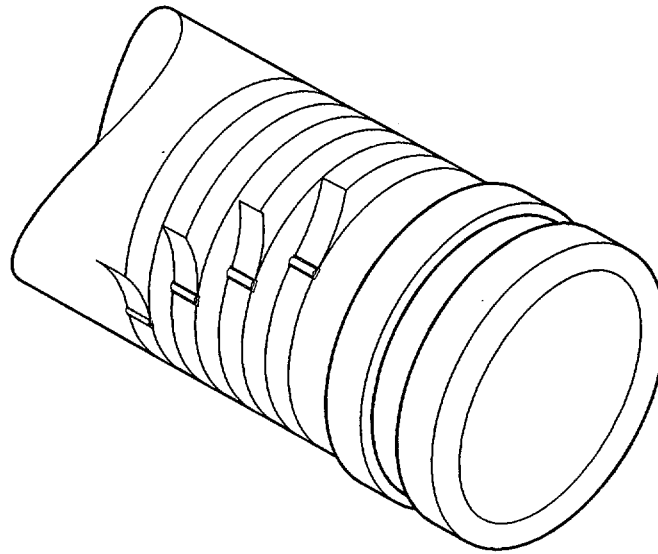


Figure 3-10. Spacing of Buckles on Repaired 6-Inch Hose Assembly.

CAUTION

To avoid leaks at adaptor shoulder, buckles must use alternately positioned as shown in figure 3-10.

- v. Repeating steps i through u, install second, third and fourth strapping and buckle in an offset as shown in figure (3-10).
- w. Repeat step h and install male quick-disconnect coupling half (1) on second hose end.

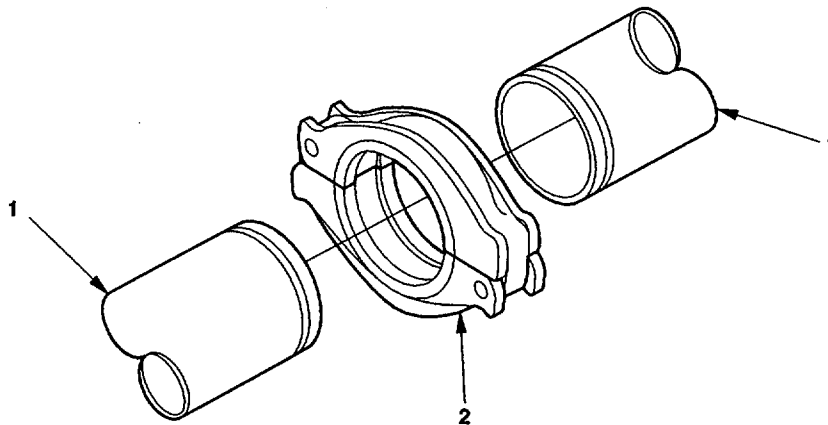


Figure 3-11. Repaired Hose Connection.

- x. Refer to paragraph 2.3.3.1 and connect hose ends (Figure 3-11, 1) with grooved-end pipe quick disconnect coupling clamp (2).
- y. Release hose clamps (Figure 3-1, 1) and inspect repaired section for leaks.

3.4.1.2 Hose Repair Using Double-Ended Adapter Repair.

NOTE

If leak is caused by a small puncture, cut hose at puncture.

- a. Refer to paragraph 3.4.1.1 and perform steps a through g.

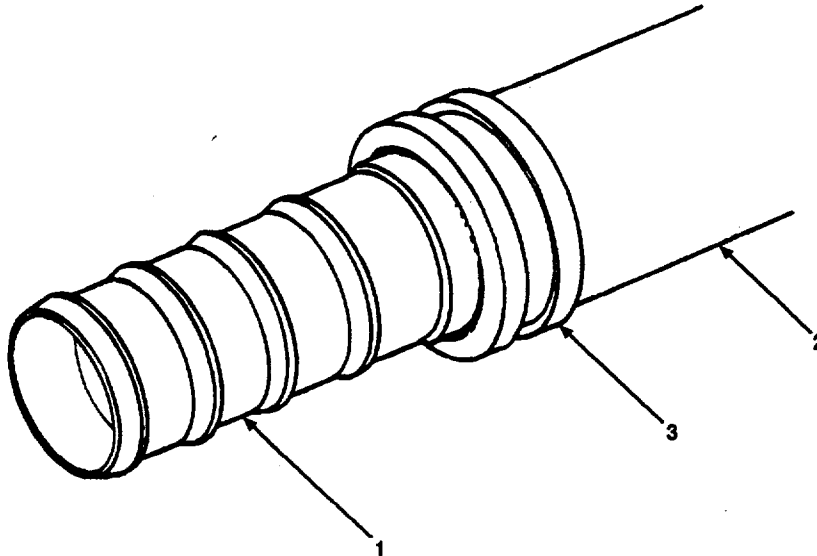


Figure 3-12. Double-Ended Adapter Installation.

- b. Insert one end of double-ended adapter (Figure 3-12, 1) into hose end (2), until shoulder (3) is flush hose end (2).
- c. Refer to paragraph 3.4.1.1 and perform steps i through v.
- d. Refer to paragraph 3.4.1.1 and perform steps a through g to install hose (2) on other end of double-ended adapter (1).
- e. Refer to paragraph 3.4.1.1 and perform steps i through v.
- f. Release hose clamps (Figure 3-1, 1) and inspect repaired section for leaks.

3.5 STORAGE ASSEMBLY MAINTENANCE .

Refer to applicable technical manual for operator maintenance procedures for the 20,000 gallon pillow tank maintenance.

3.6 125 GPM PUMPING ASSEMBLY MAINTENANCE.

Refer to applicable technical manual for operator maintenance procedures for the 125 GPM pumping assembly.

CHAPTER 4

UNIT MAINTENANCE INSTRUCTIONS

Subject Index	Page
SECTION I. REPAIR PARTS; TOOLS; SPECIAL TOOLS; TEST, MEASUREMENT, AND DIAGNOSTIC EQUIPMENT (TMDE); AND SUPPORT EQUIPMENT	4-2
4.1 Common Tools and Equipment.....	4-2
4.2 Special Tools, TMDE, and Support Equipment.....	4-2
4.3 Repair Parts.....	4-2
SECTION II. SERVICE UPON RECEIPT	4-2
4.4 Service Upon Receipt of Materiel.....	4-2
4.5 Installation Instructions.....	4-9
4.6 Preliminary Servicing and Adjustment of Equipment.....	4-9
4.7 TWDS Lubrication.....	4-9
SECTION III. UNIT PREVENTIVE MAINTENANCE CHECKS AND SERVICES	4-9
4.8 Introduction to Unit PMCS Table.....	4-9
SECTION IV. UNIT TROUBLESHOOTING	4-10
4.9 Troubleshooting	4-10
SECTION V. UNIT MAINTENANCE PROCEDURES	4-11
4.10 TWDS Supply Connection Items Maintenance.....	4-13
4.11 10-Mile Segment Equipment Maintenance.....	4-21
4.12 Storage Assembly Maintenance.....	4-35
4.13 Distribution Point Maintenance.....	4-38
4.14 Suspension Kit Maintenance.....	4-59
4.15 Displacement and Evacuation Kit Maintenance.....	4-61
4.16 Packing Kit Maintenance.....	4-63
4.17 Repair Kit Maintenance.....	4-67
4.18 Sling Assembly Maintenance.....	4-69
4.19 Preservation Procedures.....	4-71
4.20 Packing.....	4-71
4.21 Marking.....	4-72
4.22 Storage.....	4-72
4.23 Administrative Storage.....	4-72

SECTION I. REPAIR PARTS; TOOLS; SPECIAL TOOLS; TEST, MEASUREMENT, AND DIAGNOSTIC EQUIPMENT (TMDE); AND SUPPORT EQUIPMENT

4.1 COMMON TOOLS AND EQUIPMENT.

For Authorized common tools and equipment refer to the Modified Table of Organization and Equipment (MTOE) applicable to your unit.

4.2 SPECIAL TOOLS, TMDE, AND SUPPORT EQUIPMENT.

There are no special tools or support equipment required for TWDS maintenance. Refer to the paragraphs below for references to special tools and support equipment for TWDS components.

4.2.1 600 GPM Pumping Assemblies. Refer to applicable technical manual.

4.2.2 125 GPM Pumping Assembly. Refer to applicable technical manual.

4.2.3 Hypochlorination Unit, Model 1955-3. Refer to applicable technical manual.

4.2.4 Hypochlorination Unit, Model A-506131. Refer to applicable technical manual.

4.2.5 20,000 Gallon Pillow Tank. Refer to applicable technical manual.

4.3 REPAIR PARTS.

Repair parts are listed and illustrated in the repair parts and special tools list TM 10-4320-303-24P covering unit, direct support, and general support maintenance for this equipment. Refer to the paragraphs below for references to repair parts listings and illustrations for TWDS components.

4.3.1 600 GPM Pumping Assemblies. Refer to applicable repair parts and special tools list.

4.3.2 125 GPM Pumping Assembly. Refer to applicable repair parts and special tools list.

4.3.3 Hypochlorination Unit, Model 1955-3. Refer to applicable repair parts and special tools list.

4.3.4 Hypochlorination Unit, Model A-506131. Refer to applicable repair parts and special tools list.

4.3.5 20,000 Gallon Pillow Storage Tank. Refer to applicable repair parts and special tools list.

SECTION II. SERVICE UPON RECEIPT

4.4 SERVICE UPON RECEIPT OF MATERIEL.

4.4.1 Siting and Location. For information on locating and positioning of TWDS refer to paragraph 2.3.1 of this manual.

4.4.2 Unpacking.

4.4.2.1 TWDS Component Packing Groups. TWDS consists of four equipment groups divided into eight packing groups. The packing groups contain a total of 47 crates. Each crate is plywood-sheathed, skidded, and equipped with headers for using a forklift. Each crate is marked with the equipment name and packing group to which it belongs. To unpack the TWDS, perform unpacking procedures, detailed below, that apply to each equipment group. Equipment utilized depends on the specific TWDS mission. Unpack only those components required to complete the intended mission. The

following paragraphs detail each equipment group, the number of crates comprising each group, crate markings, general contents of each crate, and crate deployment.

4.4.2.2 Pumping Stations. The six trailer-mounted pumping assemblies are protected by plywood caps which rest on the trailer rails and are fastened to the unit by banding straps. All other components necessary to complete the assembly of the six pumping stations are in a crate marked "PUMPING STATIONS". Load this crate on the back of the truck used to tow the first trailer-mounted pumping assembly to the lead pumping station installation site. Tow crate and pump to installation site for lead pumping station. Transport remaining trailer-mounted pumping assemblies(boost pumping stations) to their respective installation sites.

4.4.2.3 Storage Assemblies. Components for the storage assemblies are packed in three crates. Two crates are marked "TANK, FABRIC, COLLAPSIBLE, 20K GALLON". Each of these two crates contains one 20,000 gallon pillow tank along with valves and fittings required for tank installation. The third crate is marked "STORAGE ASSEMBLY". This crate contains all other components for two storage assemblies. Transport these three crates to the first storage assembly site.

4.4.2.4 Distribution Points. Components for distribution points are packed in three crates. Two of these crates contain a 125 GPM pumping assembly and are marked "PUMP, CENTRIFUGAL, 125 GPM". The third crate is marked "DISTRIBUTION POINT". This crate contains all other components necessary to complete assembly of two distribution points. Transport the three distribution point crates to the first storage assembly site.

4.4.2.5 10-Mile Hoseline Segment. Components of the 10-mile hoseline segment are packed in 34 crates. Thirty-three crates contain hoseline and are marked "HOSE ASSEMBLY,6 INCH, 500 FEET". Each crate contains four older model flaking boxes or two newer model flaking boxes. Each older model flaking box contains one 500 foot hose assembly. Each newer model flaking box contains two 500 foot hose assemblies. The remaining crate is marked "10-MILE SEGMENT". This crate contains all other components necessary for installation of the 10-mile hoseline segment. Transport these crates to the area of the lead pumping station.

4.4.2.6 General Crate Unpacking Instructions.

CAUTION

Do not use excessive force when unpacking TWDS crates. Packing crates or components may be damaged.

- a. Be careful during unpacking not to damage container contents or packing materials.
- b. Remove lid from crate. As required, remove blocking, bracing, and anchoring securing contents within crate.
- c. Save all packing materials and store them in their opened containers after removal of crate contents.
- d. Return unused components to crates.
- e. Return all fiberboard and plywood boxes to original crates.
- f. Retain all packing materials at installation site. This will speed repacking when moving TWDS to a new site or returning to storage.

4.4.3 Checking Unpacked Equipment. Tables 4-1 through 4-5 contain a listing of all components contained in the TWDS packing crates. Each table identifies the item, item size, item quantity contained in the crate, and an inspection to be performed on each item. Refer to applicable technical manual for inspection and unpacking of the 600 GPM pumping assemblies, 20,000 gallon pillow storage tanks, and 125 GPM

4.4.3 Checking Unpacked Equipment. (Continued)

pumping assemblies. Check the equipment against the packing slip to see if the shipment is complete. Report all discrepancies, missing components, or damage in accordance with the instructions of DA Pam 738-750. Report any deficiencies found while unpacking on SF 364, Report of Deficiency.

Table 4-1. Pumping Station Crate.

Qty	Size	Item	Inspection
18	6 inch	Butterfly valve	Check gear-actuated handle for smooth operation. Ensure disc operates freely.
6	6 inch	Check valve	Ensure assembly is tight. Check for loose, missing, or damaged nuts.
6	6 inch x 10 foot	Discharge hose assembly	Inspect hose for punctures, cuts, or scrapes. Ensure bands that secure adapters are tight.
6	6 inch x 20 foot	Discharge hose assembly	Inspect hose for punctures, cuts, or scrapes. Ensure bands that secure adapters are tight.
6	6 inch x 75 foot	Discharge hose assembly	Inspect hose for punctures, cuts, or scrapes. Ensure bands that secure adapters are tight.
66	6 inch	Grooved pipe coupling	Check for damaged or missing gasket. Check for damaged or missing components.
12	6 inch	Lateral grooved pipe fitting	Check for damaged to sealing surfaces.
6	6 inch	Pressure relief valve and nipple	Check for cracked or broken components. Make sure relief valve is firmly seated in nipple.

Table 4-2. Storage Assembly Crate.

Qty	Size	Item	Inspection
32	0.375 16 UNC-2A x 3.25 inch	Bolt threads.	Check for worn, stripped, or damaged
2	4 inch	Coupling half, female, quick-disconnect	Make sure cam arms move freely. Check for damaged or missing gasket. Check for damaged threads.
2	4 inch	Coupling half, male, quick-disconnect	Check for stripped or worn threads. Check for damaged sealing surfaces.
2	4 inch	Coupling pipe fitting	Check for stripped or worn threads.
8	4 inch x 10 foot	Discharge hose assembly, quick-disconnect	Inspect hose for punctures, cuts, or scrapes. Make sure cam arms move freely. Check for damaged threads.
2	4 inch	Flange adapter	Check for damage to sealing surfaces.

Table 4-2. Storage Assembly Crate.

Qty	Size	Item	Inspection
64	0046 ID x 0812 OD	Flat washer	Check for bent or cracked washers
4	4 inch, Class 150	Gasket	Check for tears, punctures, or other damage
2	4 inch	Gate valve, flanged	make sure assembly is tight. Check for loose, damaged, or missing nuts and bolts. Check for damage to valve Make sure handwheel is firmly secured to valve stem
2	4 inch	Grooved pipe coupling	Check for damaged or missing gasket Check for damaged or missing components
2	6 inch	Grooved pipe coupling	Check for damaged or missing gasket Check for damaged or missing bolts and nuts
32	0375 16 UNC- 2B	Hex nut	Check for stripped or worn threads
32	0375 inch	Lock washer	
2	6 inch x 6 inch x 4 inch	Reducing tee	Check for damage to sealing surfaces and tee

Table 4-3. Distribution Point Crate.

Qty	Size	Item	Inspection
2		Color comparator kit	Check kit for damaged or missing contents. Check shelf life of chemicals. Ensure lock securely fastens lid on kit.
8	2 inch	Coupling half, female	Check for stripped or worn threads. Ensure cam arms move freely. Check for damaged or missing gasket.
8	2 inch	Coupling half, male	Check for stripped or worn threads. Check for damage to sealing surface.
2	2 inch x 10 foot	Discharge hose assembly	Inspect hose for punctures, cuts, or scrapes. Ensure cam arms move freely. Check for damaged or missing gasket.
14	2 inch x 20 foot	Discharge hose assembly	Inspect hose for punctures, cuts, or scrapes. Ensure cam arms move freely. Check for damaged or missing gasket.
4	36 gallon	Drinking water storage bag	Inspect bag for punctures, tears, and worn areas. Check for broken or missing faucets. Ensure faucets operate smoothly.
4	2 inch	Dust plug, quick- disconnect	Ensure dust plug is not cracked or damaged.

4.4.3 Checking Unpacked Equipment. (Continued)

Table 4-3. Distribution Point Crate. (Continued)

Qty	Size	Item	Inspection
4	2 inch x 2 inch	Elbow valve	Make sure cam arms move freely. Check for damaged or missing gasket. Make sure handwheel is firmly secured to valve stem and operates smoothly.
4	2 inch	Gate valve	Check for stripped or worn threads. Ensure handwheel is firmly secured to valve stem and operates smoothly.
2	100 gpm	Hypochlorination unit	Model 1955-1-Ensure all hoses and pipes are not damaged or cracked, all meters are not damaged or cracked, solution reservoir and tool box are present, skid frame is not damaged or broken, and all valves operate freely. Refer to applicable technical manuals for inspection of Hypochlorination unit, model 1955-3 and model A-506131.
2	2 inch x 20 foot	Suction hose assembly	Inspect hose for punctures, cuts, or scrapes. Ensure cam arms move freely. Check for damaged or missing gasket.
4		Nozzle	Check for stripped or worn threads. Ensure trigger mechanism operates smoothly.
4		Nozzle stand assembly	Inspect assembly for bent or damaged legs. Check for missing, broken, or unconnected chains. Inspect chain attachment and hook welds for cracks or separation.
4	2 inch x 1.5 inch	Reducer, quick-disconnect, threaded	Ensure cam arms move freely. Check for damaged or missing gasket. Check for stripped or worn threads.
4	2 inch x 1.5 inch	reducer, quick disconnect	Ensure cam arms move freely. Check for damaged or missing gasket.
2	2 inch x 3 inch	reducer, quick disconnect	Ensure cam arms move freely. Check for damaged or missing gasket.
2	2 inch x 4 inch	reducer, quick disconnect	Ensure cam arms move freely. Check for damaged or missing gasket.
2	4 inch x 2 inch	reducer, quick disconnect	Ensure cam arms move freely. Check for damaged or missing gasket.
6	2 inch x 2 inch x 2 inch	Y-connection, quick-disconnect	Ensure cam arms move freely. Check for damaged or missing gasket.
4	2 inch	Swivel, hose	Check for cracks or breaks.

Table 4-4. 10-Mile Segment Crate.

Qty	Size	Item	Inspection
1	6 inch	Coupling half, quick-disconnect, female	Check for stripped or worn threads. Ensure cam arms move freely. Check for damaged or missing gasket.

Table 4-4. 10-Mile Segment Crate. (Continued)

Qty	Size	Item	Inspection
1	6 inch	Coupling pipe fitting	Check for stripped or worn threads.
2		Displacement and evacuation kit	Inspect kit chest for broken handles, latches, and hinges. Open chest and check inner partitions for broken seam welds. Check kit contents (listed in appendix C) for damaged or missing items.
1	6 inch	End cap	Check for damage to sealing surfaces.
15	6 inch	Grooved pipe coupling	Check for damaged or missing gasket. Check for damaged or missing components.
1		Lifting sling	Inspect lifting sling ring for cracks or breaks. Inspect U-bolt for cracks, breaks, and looseness. Inspect lower cables to spreader bar rings for broken strands, worn thimbles, and loose clips. Inspect four lift hooks for cracks, breaks, or distortions. Inspect wire cables for broken strands, worn cable thimbles at rings and eyes, and loose cable clips.
1		Packing kit	Inspect kit chest for broken handles, latches, and hinges. Open chest and check inner partitions for broken seam welds. Check contents in each kit (listed in appendix C) for damaged or missing items.
1		Pressure-reducing valve assembly	Inspect skid for broken welds. Inspect valve for bent or broken tubing, missing parts, or other damage. Ensure valve is properly attached to skid.
1	6 inch	Pressure relief valve and nipple	Inspect relief valve and nipple for cracked or broken parts. Ensure valve is firmly seated in nipple.
1		Repair kit	Inspect kit chest for broken handles, latches, and hinges. Open chest and check inner partitions for broken seam welds. Check contents in each kit (listed in appendix C) for damaged or missing items.
24	6 inch	Road crossing guards	Inspect guards for cracks, dents, or other damage.
4	1-1/4 inch	Socket Wrench	Inspect for serviceability
2	1-1/16 inch	Socket Wrench	Inspect for serviceability
4		Socket wrench handle	Inspect for serviceability.
12	6 inch x 10 foot	Suction hose assembly	Inspect hose for punctures, cuts, or scrapes. Ensure cam arms move freely. Check for damaged or missing gasket.

4.4.3 **Checking Unpacked Equipment.** (Continued)

Table 4-4. 10-Mile Segment Crate. (Continued)

Qty	Size	Item	Inspection
NOTE Some suspension kits may contain a round stake.			
5		Suspension kit	Inspect kit chest for broken handles, latches, and hinges. Open chest and check inner partitions for broken seam welds. Check contents in each kit (listed in appendix C) for damaged or missing items.
65	6 inch	Swivel joint and coupling	Check for smooth swivel operation. Check for damaged or missing gasket. Check for damaged or missing components.
1	6 inch x 4 inch x 4 inch	Y-connection reducer	Inspect reducer assembly for missing parts. Ensure coupling pipe fitting is tightly screwed into male quick-disconnect coupling half. Inspect grooved pipe coupling for tightness. Ensure female quick-disconnect couplings are tightly screwed onto reducer pipe fittings. Ensure cam arms move freely. Check for damaged or missing gaskets on quick-disconnect and grooved pipe couplings.

Table 4-5. Hose Assembly, 6 Inch, 500 Feet Crates.

Qty	Size	Item	Inspection
132		Flaking box	Inspect all accessible frame seam welds for cracks or separated metal. Inspect four lifting clevises for cracks or distortions. Inspect four clevis attach brackets for cracked holes and cracked or separated seam welds. Inspect tailgate assembly for cracks, breaks, holes, or any other defects.
132	6 inch x 500 foot	Hose assembly, collapsible	Inspect hose for punctures, cuts, or scrapes. Ensure bands that secure adapters are tight.

4.4.4 **Deprocessing Unpacked Equipment.**

- a. Remove all tape and packing film, if any, from equipment.
- b. Remove all plastic tie-wraps, if any, necessary to place the equipment in operation.
- c. Remove all shipping tags from components and retain for future reference.
- d. Refer to DA Form 2258, Depreservation Guide for Vehicles and Equipment, packed with the equipment. The depreservation guide explains what was done to the

equipment prior to packaging. It also explains what has to be done before placing the equipment in operation. Perform all depreservation actions required by the depreservation guide.

4.5 INSTALLATION INSTRUCTIONS .

Refer to paragraph 2.3 of this manual for TWDS installation instructions.

4.6 PRELIMINARY SERVICING AND ADJUSTMENT OF EQUIPMENT .

Refer to paragraph 2.4 of this manual for preliminary servicing and adjustment of TWDS.

4.7 TWDS LUBRICATION .

The TWDS does not require any general lubrication. Refer to the applicable technical manuals for 125 GPM and 600 GPM Pumping Assemblies.

**SECTION III. UNIT PREVENTIVE MAINTENANCE
CHECKS AND SERVICES**

4.8 INTRODUCTION TO UNIT PMCS TABLE .

Table 4-7 has been provided so you can keep your TWDS equipment in good operating condition and ready for its primary mission. Additional PMCS procedures for TWDS equipment are contained in Table 2-7, Operator PMCS, and Chapter 2, Section II of this manual. Refer to applicable technical manuals for specific component PMCS:

- a. 125 GPM Pumping Assembly
- b. 20,000 Gallon Pillow Tank
- c. Hypochlorination Unit, Model A-506131
- d. Hypochlorination Unit, Model 1955-3
- e. 600 GPM Pumping Assemblies

4.8.1 Explanation of Table Entries .

4.8.1.1 Item No. Column . Numbers in this column are for reference. When completing DA Form 2404 (Equipment Inspection and Maintenance Worksheet), include the item number for the check/service indicating a fault. Item numbers also appear in the order that you must do checks and services for the intervals listed.

4.8.1.2 Interval Column . This column tells you when you must do the procedure in the procedure column. BEFORE procedures must be done before you operate or use the equipment for its intended mission. DURING procedures must be done during the time you are operating or using the equipment for its intended mission. AFTER procedures must be done immediately after you have operated the equipment.

4.8.1.3 Location and Item to Check/Service Column . This column provides the location and the item to be checked or serviced. The item location is underlined.

4.8.1.4 Procedure Column . This column gives the procedure you must do to check or service the item listed in the Check/Service column to know if the equipment is ready or available for its intended mission or for operation. You must do the procedure at the time stated in the interval column.

4.8.1.5 Not Fully Mission Capable if : Column. Information in this column tells you what faults will keep your equipment from being capable of performing its primary mission. If you make check and service procedures that show faults listed in this column, do not operate the equipment. Follow standard operating procedures for maintaining the equipment or reporting equipment failure.

4.8.2 Special Instructions. Preventive maintenance is not limited to performing only those checks and services listed in the PMCS Table. Covering unused receptacles, stowing unused accessories, and other routine procedures such as equipment inventory, cleaning components, and touch-up painting are not listed in the table. These are things you should do any time you see that they need to be done. If a routine check is listed in the PMCS Table, it is because experience has shown that problems may occur with this item. Take along tools and cleaning cloths needed to perform the required checks and services.

Table 4-6. Unit Maintenance Preventive Maintenance Checks and Services.

Item No.	Interval	Location	Procedure	Not Fully Mission Capable if:
		Item to Check/Service		
1	Weekly	<u>Hypochlorination Unit 1955-1</u> Strainer Assembly	Refer to paragraph 4.13.4. and service strainer assembly. Inspect for corrosion or damage.	Strainer is damaged or corroded.

SECTION IV. UNIT TROUBLESHOOTING

4.9 TROUBLESHOOTING.

The malfunction index lists faults that may be observed by unit maintenance personnel. The faults are then cross-referenced to the troubleshooting table, Table 4-7. Table 4-7 contains information useful in diagnosing and correcting unsatisfactory conditions which may be encountered during operation or maintenance of the TWDS. Use the malfunction index to locate specific troubleshooting procedures contained in Table 4-7. After locating the troubleshooting procedure, perform the test/inspections and corrective actions in the order listed. The malfunction index and Table 4-7 cannot list all of the malfunctions that may occur, all tests and inspections needed to find the fault, or all the corrective actions needed to correct the fault. If the equipment malfunction is not listed or actions listed do not correct the fault, notify your supervisor. Refer to the applicable technical manuals for 125 GPM and 600 GPM Pumping Assemblies, Hypochlorination Units, and for 20,000 Gallon Pillow Tank unit troubleshooting procedures.

UNIT MALFUNCTION INDEX

	Malfunction Number in Table 4-7
20,000 Gallon Pillow Tank is not being filled.....	1
Pressure-reducing valve assembly will not open or will not close drip-tight.....	2
Hypochlorination unit, model 1955-1 pressure gauge shows high pressure.....	3
Hypochlorination unit, model 1955-1 camshaft is turning but spring is not moving.....	4
Little or no water flow at distribution points.....	5

Table 4-7. Unit Troubleshooting Table.**MALFUNCTION****TEST OR INSPECTION****CORRECTIVE ACTION****1. 20,000 GALLON PILLOW TANK IS NOT BEING FILLED.**

Step 1. Check to see if pressure-reducing valve assembly is damaged.

Refer to paragraph 4.11.5 and replace pressure-reducing valve assembly.

Step 2. Refer to applicable technical manual and troubleshoot 20,000 gallon pillow tank.

2. PRESSURE-REDUCING VALVE ASSEMBLY WILL NOT ALLOW WATER TO FLOW.**WARNING**

Assembly may be pressurized. Personal injury may result if pressure is not reduced before performing maintenance on pressure-reducing valve assembly.

Step 1. Check isolation tubing for obstructions.

a. If found, remove obstructions.

Step 2. Close inlet isolation cock valve.

a. If valve opens, replace regulator control.

b. If valve remains closed, notify direct support maintenance.

3. PRESSURE-REDUCING VALVE IS NOT REDUCING PRESSURE.**WARNING**

Assembly may be pressurized. Personal injury may result if pressure is not reduced before performing maintenance on pressure-reducing valve assembly.

Step 1. Check isolation tubing for obstruction.

a. If found, remove obstructions.

Step 2. Ensure that inlet and cover isolation cock valves are open, then close outlet isolation cock valve.

a. If main valve closes, replace pressure-reducing control valve.

b. If main valve opens, notify direct support for diaphragm and spring maintenance.

4. HYPOCHLORINATION UNIT, MODEL 1955-1 PRESSURE GAUGE SHOWS HIGH PRESSURE.

Check pressure gauge for damage.

Refer to paragraph 4.13.3 and replace pressure gauge.

5. HYPOCHLORINATION UNIT, MODEL 1955-1 CAMSHAFT IS TURNING BUT SPRING IS NOT MOVING.

Check to see if pressure regulator setting is not accurate. Correct valve setting.

Table 4-7. Unit Troubleshooting Table. (Continued)

MALFUNCTION**TEST OR INSPECTION****CORRECTIVE ACTION**

6. LITTLE OR NO WATER FLOW AT DISTRIBUTION POINTS.

Step 1. Check nozzles and elbow valve assemblies for damage or defective parts.

- a. Refer to paragraph 2.8.6 and replace damaged or defective nozzle.
- b. Refer to paragraph 2.8.6 and replace damaged or defective elbow valve assemblies.

SECTION V. UNIT MAINTENANCE PROCEDURES

4.10 TWDS SUPPLY CONNECTION ITEMS MAINTENANCE

4.10.1 Reducer Y-Connection Maintenance.

This task covers:

4.10.1.1 Removal	4.10.1.4 Repair
4.10.1.2 Disassembly	4.10.1.5 Assembly
4.10.1.3 Inspection'	4.10.1.6 Installation

INITIAL SETUP

Tools

Tool Kit, General Mechanic's,
Automotive, Section III, Item 1,
Appendix B

Material/Parts

Antiseize Tape, Item 9, Appendix E
Silicon Lubricant, Item 5, Appendix E
Gasket (TM 10-4320-303-23P)

Equipment Conditions

Lead pumping station shutdown, refer to applicable technical manual.

General Safety Instructions

Do not work on equipment without following standard shop safety precautions.

4.10.1.1 Removal.

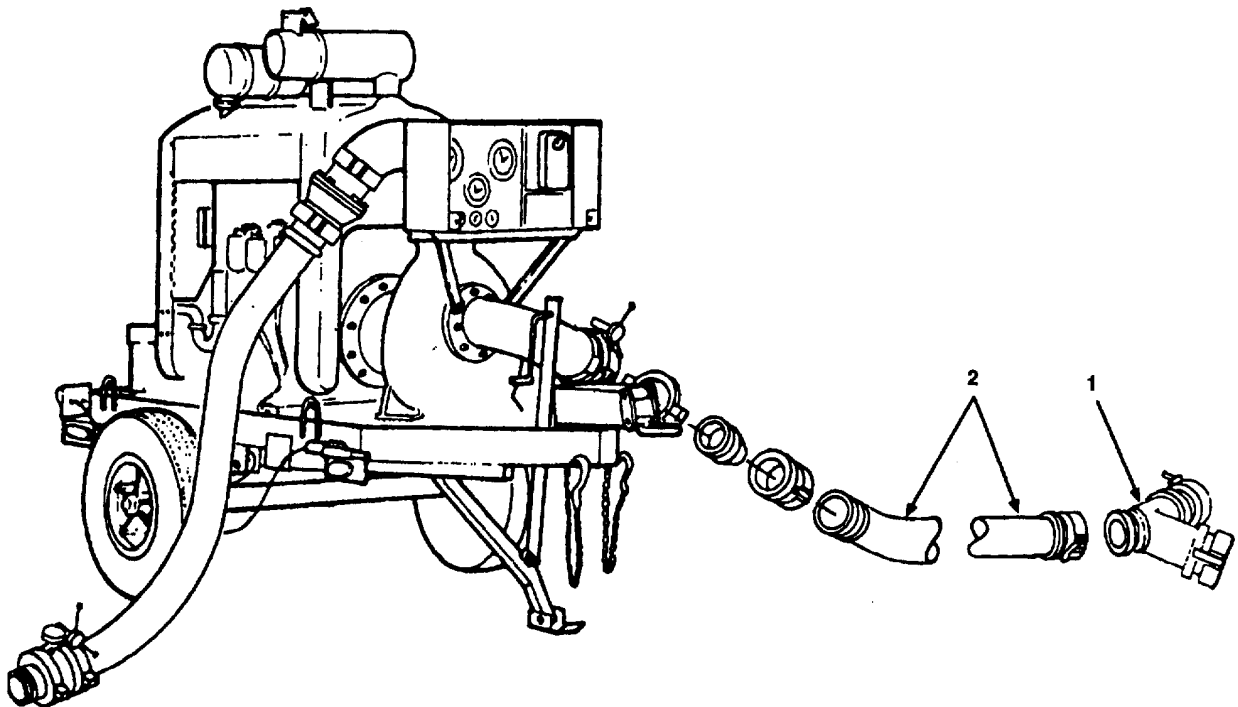


Figure 4-1. Reducer Y-Connection Removal.

- a. Open cam arms and disconnect reducer Y-connection (Figure 4-1, 1) from water source.

4.10.1 Reducer Y-Connection Maintenance. (Continued)

- b. Open cam arms on 6 inch x 10 foot suction hose assembly (2) and remove reducer Y-connection (1) from 6 inch x 10 foot suction hose assembly (2).

4.10.1.2 Disassembly.

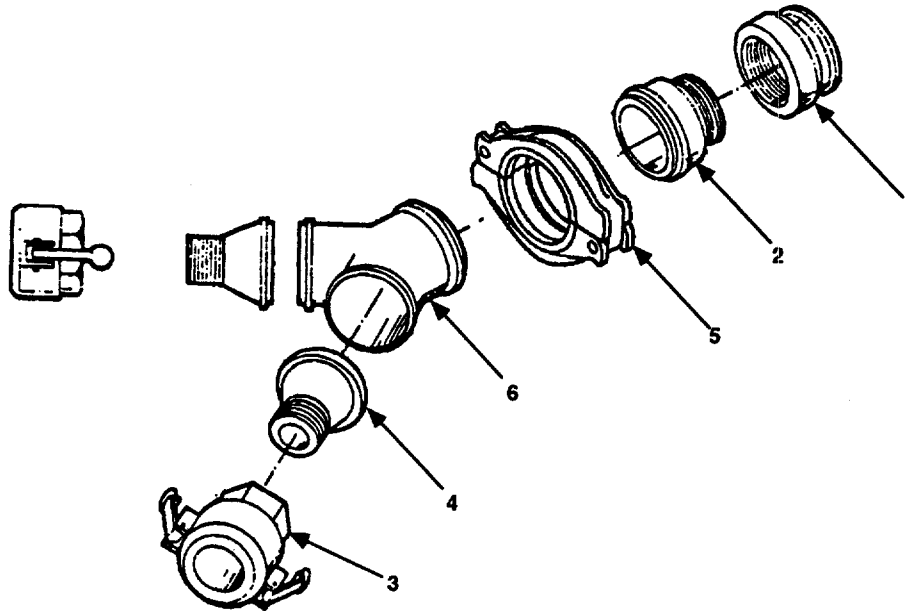


Figure 4-2. Reducer Y-Connection Disassembly.

- Remove quick-disconnect male coupling half (Figure 4-2, 1) from grooved pipe coupling fitting (2).
- Remove two female quick-disconnect couplings (3) from reducer pipe fittings (4). Discard gaskets of female quick-disconnect couplings (3).
- Remove three grooved-end pipe quick disconnect coupling clamps (5) (paragraph 2.3.3.1).
- Remove two reducer pipe fittings (4) from Y-fitting (6).
- Remove Y-fitting (6) from grooved pipe coupling fitting (2).

4.10.1.3 Inspection.

- Inspect grooved-end pipe quick disconnect coupling clamps (6) for cracks, bends, damage, or ripped, torn, sliced, or damaged gasket.
- Inspect two female quick-disconnect couplings (3) for cracks, holes, broken or missing cam arms, or damage.
- Inspect quick-disconnect male coupling half (1), grooved pipe coupling fitting (2), two reducer pipe fittings (4), and Y-fitting (6) for corrosion, cracks, holes, or damage.

4.10.1 Reducer Y-Connection Maintenance. (Continued)

4.10.1.4 Repair. Repair of reducer Y-connection consists of replacing all defective components.

4.10.1.5 Assembly.

- a. Place Y-fitting (6) together with grooved pipe coupling fitting (2).
- b. Install one grooved-end pipe quick disconnect coupling clamp (5).
- c. Place two reducer pipe fittings (4) together with Y-fitting (6).
- d. Install two grooved-end pipe quick disconnect coupling clamps (5).

NOTE

Wrap antiseize tape in direction of threads.

- e. Wrap antiseize tape around threads of two reducer pipe fittings (4) and grooved pipe coupling fitting (2).
- f. Coat two new gaskets with non-petroleum based silicone lubricant and install them in two female quick-disconnect couplings (3). Install two female quick-disconnect couplings (3) on two reducer pipe fittings (4).
- g. Install quick-disconnect male coupling half (1) on grooved coupling pipe fitting (2).

4.10.1.6 Installation.

- a. Open cam arms on 6 inch x 10 foot suction hose assembly (Figure 4-1, 2) and install reducer Y-connection (1) in 6 inch x 10 foot suction hose assembly (2).

CAUTION

To prevent leakage, close both cam arms at the same time. Do not strike cam arms to close. Damage to couplings could result.

- b. Close cam arms on 6 inch x 10 foot suction hose assembly (2).

4.10.2 6 Inch Butterfly Valve Assembly Maintenance.

This task covers:

4.10.2.1	Removal	4.10.2.4	Repair
4.10.2.2	Disassembly	4.10.2.5	Assembly
4.10.2.3	Inspection	4.10.2.6	Installation

INITIAL SETUP

Tools

Tool Kit, General Mechanic's,
Automotive, Section III, Item 1,
Appendix B

Materiel/Parts

Lock washers (TM 10-4320-303-23P)
Preformed packing (TM 10-4320-303-23P)

General Safety Instructions

Do not work on equipment without following standard shop safety precautions.

Equipment Conditions

Pumping station shutdown, refer to applicable technical manual.

4.10.2.1 Removal.

NOTE

There are 3 versions of the 6 Inch Butterfly Valve assembly used with TWDS. These procedures cover the 6 Inch Butterfly Valve shown. The maintenance procedures for the others are similar.

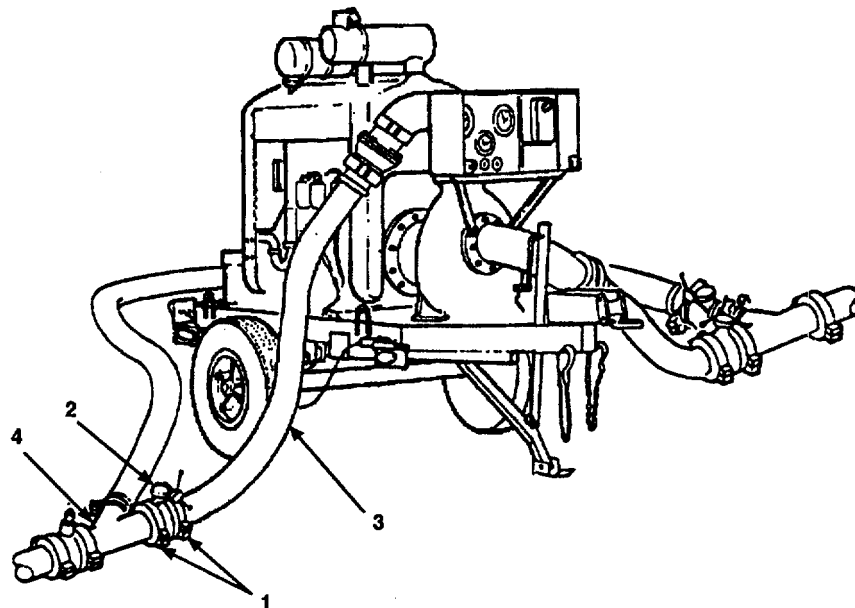


Figure 4-3. 6 Inch Butterfly Valve Assembly Removal.

- a. Remove two grooved-end pipe quick-disconnect coupling clamps (Figure 4-3, 1) securing 6 inch butterfly valve assembly (2) to 6 inch X 20 foot hose assembly (3) and lateral grooved pipe fitting (4).
- b. Remove 6 inch butterfly valve assembly (2).

4.10.2.2 Disassembly.

- a. Remove two bolts (Figure 4-4, 1), lock washers (2) and remove handle assembly (3) from mounting plate (4). Discard lock washers (2).

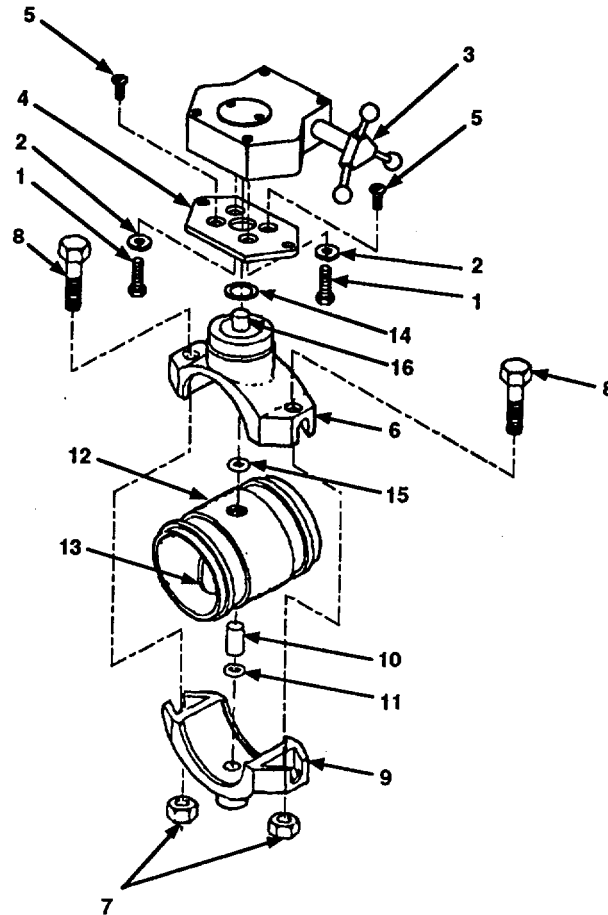


Figure 4-4. 6 Inch Butterfly Valve Assembly Disassembly.

- b. Remove two screws (5) and remove mounting plate (4) from upper housing (6).
- c. Remove two nuts (7) and bolts (8).
- d. Carefully separate upper housing (6) and lower housing (9).
- e. Remove lower stem (10) and preformed packing (11) from lower housing (9). Discard preformed packing (11).
- f. Remove body (12) from upper housing (6).
- g. Remove disc (13) from body (12).
- h. Remove washer (14) and preformed packing (15) from upper stem (16). Discard preformed packing (15).
- i. Remove upper stem (16) from upper housing (6).

4.10.2.3 Inspection.

- a. Inspect handle assembly (3) for cracks, damage, and smooth operation of handle.
- b. Inspect mounting plate (4), upper housing (6) and lower housing (9) for cracks, holes, or damage.
- c. Inspect lower stem (10), body (12), disc (13), and upper stem (16) for corrosion, cracks, holes, or damage.

4.10.2 6 Inch Butterfly Valve Assembly Maintenance. (Continued)

d. Inspect all mounting hardware for corrosion or damage.

4.10.2.4 Repair. Repair consists of replacing all damaged or defective components.

4.10.2.5 Assembly.

- a. Install upper stem (16) in upper housing (6).
- b. Install new preformed packing (15) and washer (14) on upper stem (16).
- c. Install disc (13) in body (12). Ensure holes in top and bottom of disc (13) are aligned with holes in top and bottom of body (12).
- d. Install body (12) in upper housing (6). Ensure upper stem (16) is inserted through body (12) and installed securely in upper mounting hole of disc (13).
- e. Install new preformed packing (11) and lower stem (10) in lower housing (9).
- f. Install lower housing (9) on body (12) and upper housing (6) assembly. Ensure lower stem (10) is inserted through body (12) and installed securely in mounting lower hole of disc (13).
- g. Carefully align upper housing (6) and lower housing (9) and install two bolts (8) and nuts (7). Tighten nuts (7).
- h. Place mounting plate (4) on upper housing (6). Install two screws (5). Tighten screws (5).
- i. Install handle assembly (3) on mounting plate (4).
- j. Install two new lock washers (2) and bolts (1). Tighten bolts (1).

4.10.2.6 Installation.

- a. Install 6 inch butterfly valve assembly (Figure 4-3, 2) next to 6 inch X 20 foot hose assembly (3) and lateral grooved pipe fitting (4).
- b. Install two grooved-end pipe quick-disconnect coupling clamps (1) securing 6 inch butterfly valve assembly (2) to 6 inch X 20 foot hose assembly (3) and lateral grooved pipe fitting (4).

4.10.3 Hose Assembly Replacement.

This task covers:

4.10.3.1 Removal

4.10.3.2 Installation

INITIAL SETUP

Tools

Tool Kit, General Mechanic's,
Automotive, Section III, Item 1,
Appendix B

General Safety Instructions

Do not work on equipment without following
standard shop safety precautions.

Equipment Conditions

Pumping station shutdown, refer to
applicable technical manual.

4.10.3.1 Removal.

NOTE

This procedure is applicable to the 6 inch x 20 foot hose assembly. The procedures for replacing the 6 inch x 10 foot and 6 inch x 75 foot hose assemblies are similar in nature.

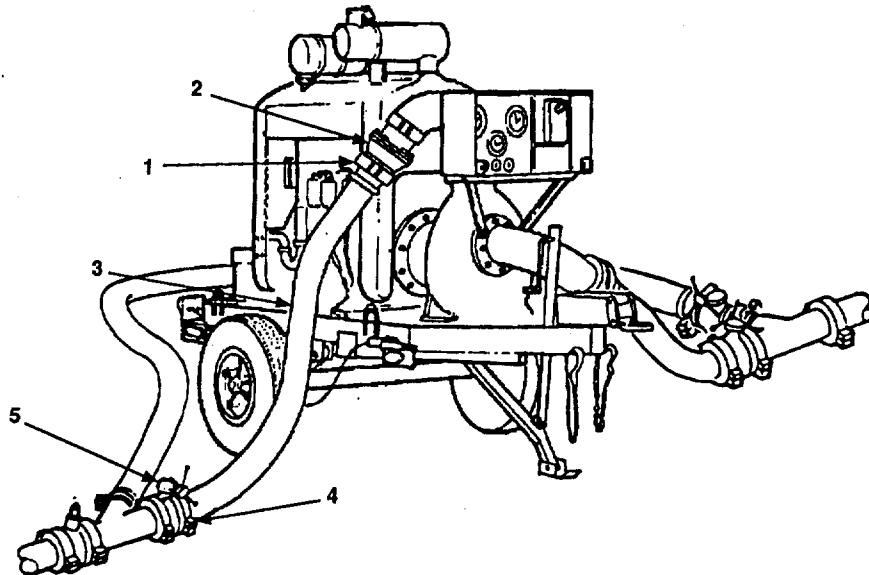


Figure 4-5. Hose Assembly Replacement.

- a. Remove 6 inch grooved pipe coupling (Figure 4-5, 1) from check valve (2) and 6 inch x 20 foot hose assembly (3).
- b. Remove grooved-end pipe quick disconnect coupling clamp (4) from 6 inch butterfly valve assembly (5) and 6 inch x 20 foot hose assembly (3).
- c. Remove 6 inch x 20 foot hose assembly (3).

4.10.3.2 Installation.

- a. Align 6 inch x 20 foot discharge hose assembly (3) for installation.

4.10.3 Hose Assembly Replacement. (Continued)

- b. Install grooved-end pipe quick disconnect coupling clamp (4) to secure 6 inch x 20 foot hose assembly (3) to 6 inch butterfly valve assembly (5).
- c. Install 6 inch grooved pipe coupling (1) to secure 6 inch x 20 foot hose assembly (3) to check valve (2).

4.11 10-MILE SEGMENT EQUIPMENT MAINTENANCE.

4.11.1 6 Inch x 500 Foot Collapsible Hose Assembly Replacement.

This task covers:

4.11.1.1 Removal

4.11.1.2 Installation

INITIAL SETUP

Tools

Tool Kit, General Mechanic's,
Automotive, Section III, Item 1,
Appendix B

General Safety Instructions

Do not work on equipment without following
standard shop safety precautions.

Equipment Conditions

Pumping station shutdown, refer to
applicable technical manual.

4.11.1.1 Removal.

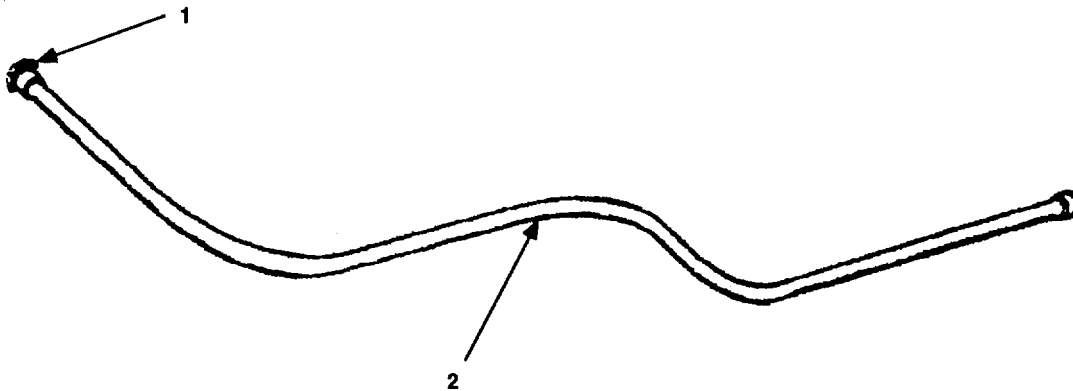


Figure 4-6. 6 Inch x 500 Foot Collapsible Hose Assembly Replacement.

- a. Remove two 6 inch grooved pipe couplings (Figure 4-6, 1) from 6 inch x 500 foot collapsible hose assembly (2).
- b. Remove 6 inch x 500 foot collapsible hose assembly (2).

4.11.1.2 Installation.

- a. Align 6 inch x 500 foot collapsible hose assembly (2) with upline and downline 6 inch x 500 foot collapsible hose assemblies.
- b. Install two 6 inch grooved pipe couplings (1) to secure 6 inch x 500 foot collapsible hose assembly (2) with upline and downline 6 inch x 500 foot collapsible hose assemblies.

4.11.2 Flaking Box Assembly Maintenance.

This task covers:

- | | |
|----------------------------------|-------------------|
| 4.11.2.1 Disassembly | 4.11.2.3 Repair |
| 4.11.2.2 Inspection and Cleaning | 4.11.2.4 Assembly |

INITIAL SETUP

Tools

Tool Kit, General Mechanic's,
Automotive, Section III, Item 1,
Appendix B

Goggles, Section III, Item 2,
Appendix B

Material/Parts

Cleaning Solvent, Item 8, Appendix E
Gloves, Item 4, Appendix E
Rags, Item 7, Appendix E
Cotter Pin (TM 10-4320-303-23P)

Equipment Conditions

Hose(s) removed
Pumping station shutdown, refer to
applicable technical manual.

General Safety Instructions

Do not work on equipment without following
standard shop safety precautions.

4.11.2.1 Disassembly.

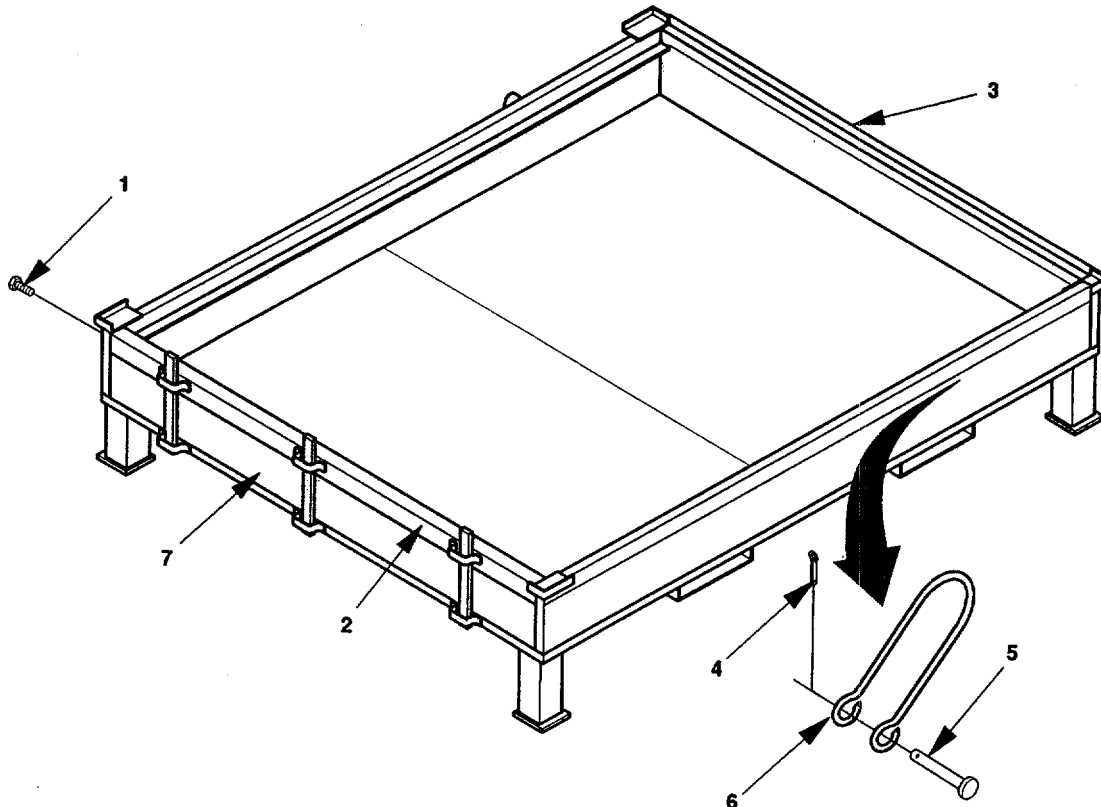


Figure 4-7. Flaking Box Assembly Maintenance.

- a. Remove two bolts (Figure 4-7, 1) and tie bar (2) from flaking box assembly (3).
- b. Remove and discard four cotter pins (4).
- c. Remove four clevis pins (5) and clevises (6) from flaking box assembly (3).
- d. Remove tailgate assembly (7) from flaking box assembly (3).

4.11.2.2 Inspection and Cleaning.

- a. Inspect tie bar (2), flaking box assembly (3), clevis pin (5), clevis (6), and tailgate assembly (7) for corrosion, cracks, bends, and damage.
- b. Inspect two bolts (1) for corrosion and damage.

WARNING

- Dry cleaning solvent used to clean parts is potentially dangerous to personnel and property. Avoid repeated or prolonged skin contact. Do not use near open flame or excessive heat. Flash point of solvent is 100-138 degrees Fahrenheit (38-60o C).
 - Wear goggles and gloves when using cleaning solvent,
 - Failure to obey these warnings may result in death or personal injury.
- c. Clean two bolts (1), tie bar (2), clevis pin (5), and clevis (6) which are not damaged.
 - d. Allow cleaned components to thoroughly air dry.

4.11.2.3 Repair. Repair of flaking box assembly (3) consists of replacing damaged or defective components. Notify Direct Support Maintenance for welding.

4.11.2.4 Assembly.

- a. Insert tailgate assembly (7) into flaking box assembly (3).
- b. Align mounting holes of four devises (6) with clevis mounting holes on flaking box assembly (3).
- c. Install four clevis pins (5) and new cotter pins (4).
- d. Align mounting holes of tie bar (2) with tie bar mounting holes of flaking box assembly (3).
- e. Install two bolts (1). Tighten bolts (1).

4.11.3 Swivel Joint Replacement.

This task covers:

4.11.3.1 Removal

4.11.3.3 Installation

4.11.3.2 Inspection

INITIAL SETUP**Tools**

Tool Kit, General Mechanic's,
Automotive, Section III, Item 1,
Appendix B

General Safety Instructions

Do not work on equipment without following
standard shop safety precautions.

Equipment Conditions

Pumping station shutdown, refer to
applicable technical manual.

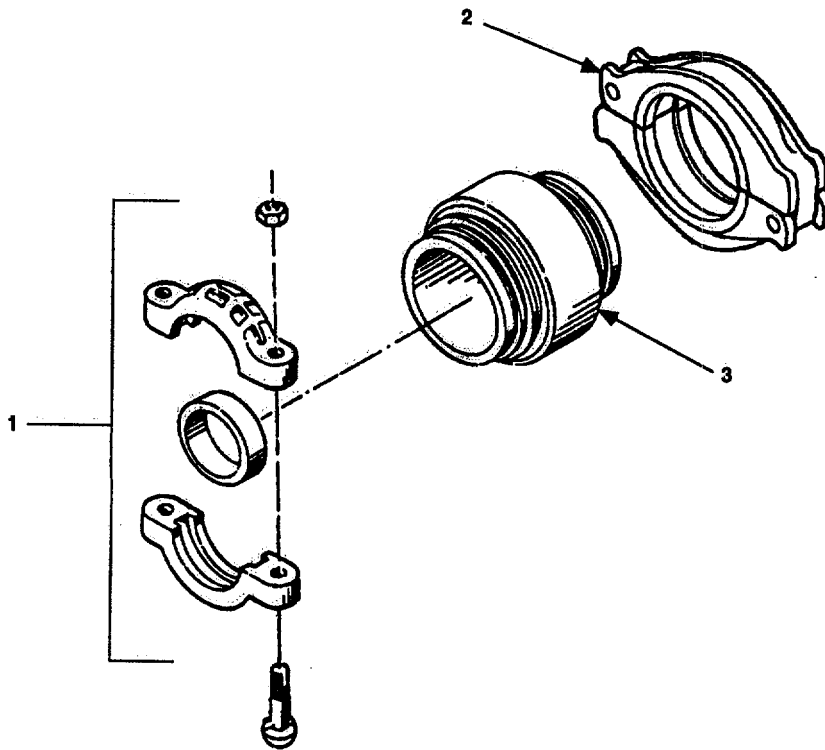
4.11.3.1 Removal.

Figure 4-8. Swivel Joint Replacement.

- a. Remove 6 inch grooved pipe coupling clamp (Figure 4-8, 1).
- b. Remove grooved-end pipe quick disconnect coupling clamp (2).
- c. Remove swivel joint (3).

4.11.3.2 Inspection.

- a. Inspect swivel joint (3) for corrosion, cracks, holes, and damage.
- b. Replace damaged or defective swivel joint (3).

4.11.3.3 Installation.

- a. Align swivel joint (3) for installation into hoseline segment.
- b. Install grooved-end pipe quick disconnect coupling clamp (2) to secure swivel joint (3) to hoseline segment.
- c. Install 6 inch grooved pipe coupling clamp (1) to secure swivel joint (3) to hose line segment.

4.11.4 Pressure-Reducing Valve Assembly Replacement.

This task covers:

4.11.4.1 Removal

4.11.4.2 Inspection

4.11.4.3 Installation

INITIAL SETUP

Tools

Tool Kit, General Mechanic's,
Automotive, Section III, Item 1,
Appendix B

General Safety Instructions

Do not work on equipment without following
standard shop safety precautions.

Equipment Conditions

Pumping station shutdown, refer to
applicable technical manual.

4.11.4.1 Removal.

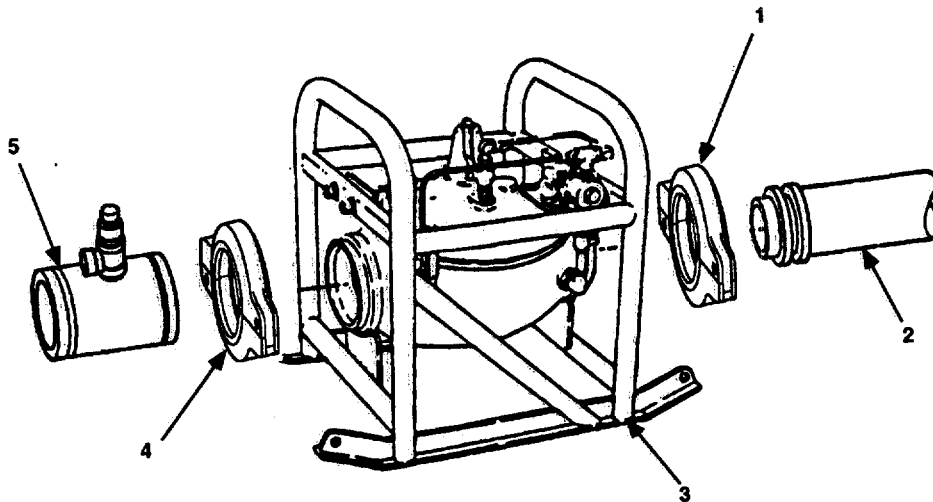


Figure 4-9. Pressure-Reducing Valve Assembly Replacement.

- a. Remove grooved-end pipe quick disconnect coupling clamp (Figure 4-9, 1) from downline 6 inch x 500 foot collapsible hose assembly (2) and pressure-reducing valve assembly (3).
- b. Remove grooved-end pipe quick disconnect coupling clamp (4) from pressure relief valve assembly (5) and pressure-reducing valve assembly (3).
- c. Remove pressure-reducing valve assembly (3).

4.11.4.2 Inspection.

- a. Inspect pressure-reducing valve assembly (3) for leaks, cracks, holes, missing components, or damage.
- b. Replace damaged or defective pressure-reducing valve assembly (3).

4.11.4.2 Installation.

- a. Align pressure relief valve assembly (5) and pressure-reducing valve assembly (3).

- b. Install grooved-end pipe quick disconnect coupling clamp (4) to secure pressure relief valve (5) to pressure-reducing valve assembly (3).
- c. Align downline 6 inch x 500 foot collapsible hoseline assembly (2) and pressure reducing valve assembly (3).
- d. Install grooved-end pipe quick disconnect coupling clamp (1) to secure downline 6 inch x 500 foot collapsible hose assembly (2) and pressure-reducing valve assembly (3).

4.11.5 Pressure-Reducing Valve Assembly Maintenance.

This task covers:

- | | |
|----------------------|-----------------------|
| 4.11.5.1 Removal | 4.11.5.3 Inspection |
| 4.11.5.2 Disassembly | 4.11.5.4 Assembly |
| | 4.11.5.5 Installation |

INITIAL SETUP

Tools

Tool Kit, General Mechanic's,
Automotive, Section III, Item 1
Appendix B

Material/Parts

Antiseize tape, Item 9, Appendix E

Lock washers (TM 10-4320-303-23P)

Equipment Conditions

Pumping station shutdown, refer to applicable technical manual.

Pressure-Reducing Valve Assembly removed, refer to paragraph 4.11.4.

Personnel

Two (2) personnel are required for lifting main valve assembly from skid assembly.

General Safety Instructions

Do not work on equipment without following standard shop safety precautions.

4.11.5.1 Removal.

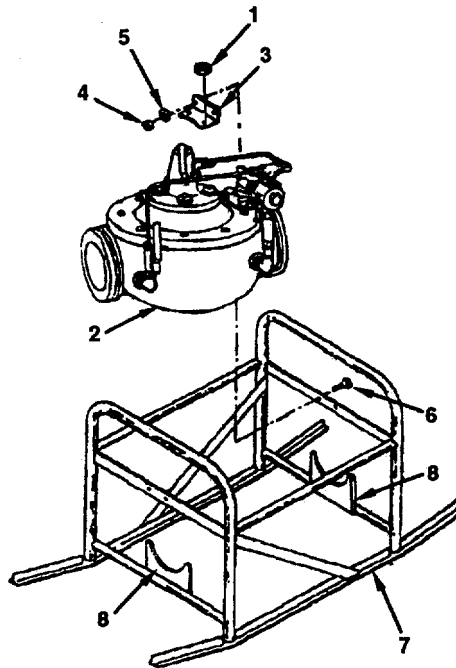


Figure 4-10. Pressure-Reducing Valve Assembly Maintenance.

- a. Remove four nuts (Figure 4-10, 1) securing main valve assembly (2) to two mounting brackets (3).

- b. Remove two nuts (4), lock washers (5), and mounting bolts (6) securing each mounting bracket (3) to skid assembly (7). Discard lock washers (5).
- c. Remove mounting brackets (3).

WARNING

Two personnel are required for lifting main valve assembly. Failure to obey this warning may result in personnel injury.

CAUTION

When removing main valve assembly ensure that tubing does not become damaged.

- d. Carefully remove main valve assembly (2) from skid assembly (7).

4.11.5.2 Disassembly.

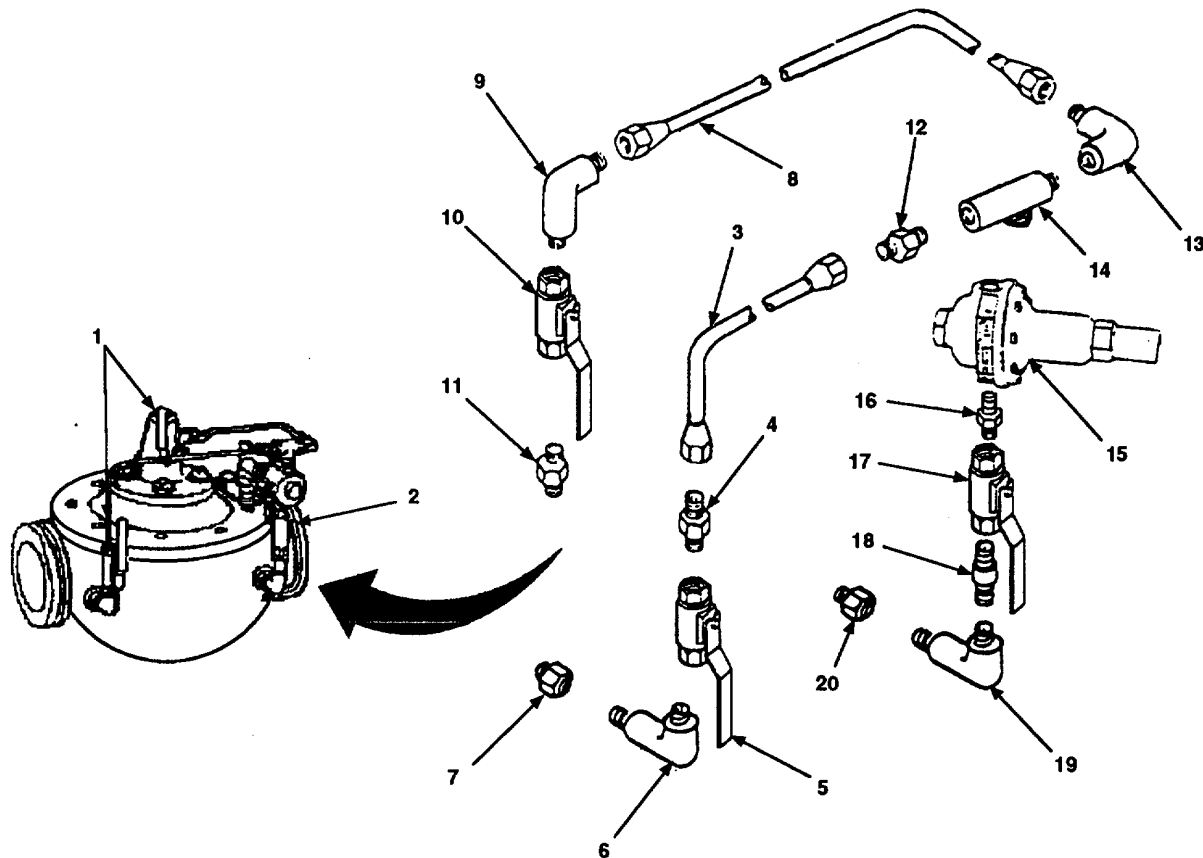


Figure 4-11. Pressure-Reducing Valve Assembly Tubing and Pressure-Reducing Control Maintenance.

- a. Open cover isolation cock valves (Figure 4-11, 1) to release pressure inside main valve assembly (2).
- b. Remove tubing (3).
- c. Remove reducer (4) from isolation cock valve (5).

4.11.5 Pressure Reducing Valve Assembly Maintenance. (Continued)

- d. Remove isolation cock valve (5).
- e. Remove elbow (6) from reducer (7).
- f. Remove reducer (7) from body of main valve assembly (2).
- g. Remove tubing (8).
- h. Remove elbow (9) from isolation cock valve (10).
- i. Remove isolation cock valve (10) from reducer (11).
- j. Remove reducer (11) from cover of main valve assembly (2).
- k. Remove reducer (12) and elbow (13) from pipe tee (14).
- l. Remove pipe tee (14) from main valve assembly (15).
- m. Remove pressure-reducing control assembly (15).
- n. Remove pipe nipple (16) from isolation cock valve (17).
- o. Remove isolation cock valve (17).
- p. Remove pipe nipple (18) from elbow (19).
- q. Remove elbow (19) from reducer (20).
- r. Remove reducer (20) from body of main valve assembly (2).

4.11.5.2 Inspection.

- a. Inspect main valve assembly (Figure 4-10, 2) for evidence of leaks, cracks, holes, missing components, or damage.
- b. Inspect mounting brackets (3) and skid assembly (7) for cracks, bends, holes, or damage.
- c. Return damaged or defective main valve assembly (2) and skid assembly (7) to direct support maintenance.
- d. Replace all damaged mounting hardware and mounting brackets (3).
- e. Inspect all tubing (Figure 4-11, 3 and 8), reducers (4, 7, 11, 12, and 20), elbows (6, 9, 13, and 19), pipe tee (14), and pipe nipples (16 and 18) for corrosion, cracks, and damage.
- f. Inspect isolation cock valves (5, 10, and 17) for corrosion, cracks, smooth operation of handle, and damage.
- g. Inspect pressure-reducing control (15) for cracks, holes, missing components and damage. Return damaged or defective pressure-reducing control (15) to direct support maintenance.
- h. Replace all damaged or defective components.

4.11.5.3 Assembly.**NOTE**

- Wrap all male threaded surfaces with antiseize tape prior to installation in the following procedures.
 - Wrap antiseize tape in direction of threads.
- a. Install reducer (Figure 4-11, 20) on main valve assembly (2).
 - b. Install elbow (19) on reducer (20).
 - c. Install pipe nipple (18) in elbow (19).
 - d. Install isolation cock valve (17) on pipe nipple (18).
 - e. Install pipe nipple (16) on isolation cock valve (17).

CAUTION

Make sure pressure-reducing control is installed with arrow pointing in direction of water flow. Failure to do so may result in damage to the equipment.

- f. Install pressure-reducing control (15) on pipe nipple (16).
- g. Install pipe tee (14) on pressure-reducing control assembly (15).
- h. Install reducer (12) and elbow (13) on pipe tee (14).
- i. Install reducer (11) in cover of main valve assembly (2).
- j. Install isolation cock valve (10) on reducer (11).
- k. Install elbow (9) on isolation cock valve (10).
- l. Install tubing (8) on elbows (9 and 13).
- m. Install reducer (7) in body of main valve assembly (2).
- n. Install elbow (6) in reducer (7).
- o. Install isolation cock valve (5) on elbow (6).
- p. Install reducer (4) on isolation cock valve (5).
- q. Install tubing (3) on reducer (4) and reducer (12).
- r. Place all cock valves (1) in open position.

4.11.5 Pressure Reducing Valve Assembly Maintenance. (Continued)**4.11.5.4 Installation.****WARNING**

Two personnel are required for lifting main valve assembly. Failure to obey this warning may result in personnel injury.

CAUTION

When installing main valve assembly ensure that tubing does not become damaged.

- a. Install main valve assembly (Figure 4-10, 2) on skid assembly (7). Ensure valve inlet and outlet ports rest securely on skid assembly mounting brackets (8).
- b. Install mounting brackets (3) on main valve assembly (2) and align holes in mounting brackets (3) with mounting holes on skid assembly (7).
- c. Install two mounting bolts (6), new lock washers (5), and nuts (4) in each mounting bracket (3). Tighten nuts (4).
- d. Install four nuts (1). Tighten nuts (1).

4.11.6 Pressure Relief Valve Assembly Maintenance.

This task covers:

- 4.11.6.1 Disassembly
- 4.11.6.2 Inspection

- 4.11.6.3 Repair
 - 4.11.6.4 Assembly
-

INITIAL SETUP

Tools

Tool Kit, General Mechanic's,
Automotive, Section III, Item 1,
Appendix B

Material/Parts

Antiseize Tape, Item 9, Appendix E

Equipment Conditions

Pumping station shutdown, refer to
applicable technical manual.

Pressure Relief Valve Assembly removed,
refer to paragraph 2.8.2.6.

General Safety Instructions

Do not work on equipment without following
standard shop safety precautions.

4.11.6.1 Disassembly.

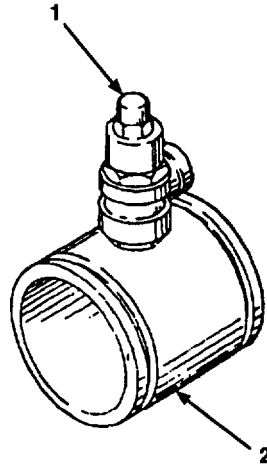


Figure 4-12. Pressure Relief Valve Assembly Maintenance.

- a. Unscrew and remove safety relief valve (Figure 4-12, 1) from pipe coupling (2).

4.11.6.2 Inspection.

- a. Inspect safety relief valve (1) for cracks, holes, or damage.
- b. Inspect pipe coupling (2) for cracks, holes, bends, or damage.

4.11.6.3 Repair. Repair of pressure relief valve assembly consists of replacing damaged or defective safety relief valve (1) or pipe coupling (2).

4.11.6 Pressure Relief Valve Assembly Maintenance. (Continued)

NOTE

Wrap antiseize tape in direction of threads.

4.11.6.4 Assembly. Wrap antiseize tape around threads of safety relief valve (1) and install in pipe coupling (2).

4.12 STORAGE ASSEMBLY MAINTENANCE.

4.12.1 4 Inch Gate Valve Assembly Maintenance.

This task covers:

- | | |
|----------------------|-----------------------|
| 4.12.1.1 Removal | 4.12.1.4 Repair |
| 4.12.1.2 Disassembly | 4.12.1.5 Assembly |
| 4.12.1.3 Inspection | 4.12.1.6 Installation |

INITIAL SETUP

Tools

Tool Kit, General Mechanic's,
Automotive, Section III, Item 1,
Appendix B

Material/Parts

Gasket (TM 10-4320-303-23P)
Packing (TM 10-4320-303-23P)

Equipment Conditions

Pumping station shutdown, refer to
applicable technical manual

Equipment Conditions (Continued)

Quick-Disconnect Coupling Half removed,
refer to paragraph 2.8.5.2.

Flange Adapter removed, refer to paragraph
2.8.5.2.

General Safety Instructions

Do not work on equipment without following
standard shop safety precautions.

4.12.1.1 Removal. Placing the 4 inch gate valve assembly (Figure 4-13, 1) in the equipment conditions specified above will remove the 4 inch gate valve assembly (1) from the storage assembly.

4.12.1.2 Disassembly.

- a. Remove nut (2) and handwheel (3).
- b. Remove packing nut (4).
- c. Remove packing gland (5), packing (6), and spring (7). Discard packing (6).
- d. Remove eight screws (8) and lock washers (9). Discard lock washers (9).
- e. Remove bonnet (10) and gasket (11) from valve body (12). Discard gasket (11).
- f. Unscrew valve stem (13) and remove from bonnet (10).
- g. Remove disc assembly (14) from valve stem (13).
- h. Remove two screws (15).
- i. Separate two discs (15 and 16) from pull nut (17).

4.12.1.3 Inspection.

- a. Inspect handwheel (3), bonnet (9), valve body (11), bonnet stem (12), disc stem (13), discs (14 and 15) and two seat rings (16) for corrosion, cracks, holes, bends or damage.
- b. Inspect nut (2), packing nut (4), packing gland (5), eight screws (7), and lock washers (8) for corrosion or damage.

4.12.1.4 Repair. Repair consists of replacing defective or damaged components.

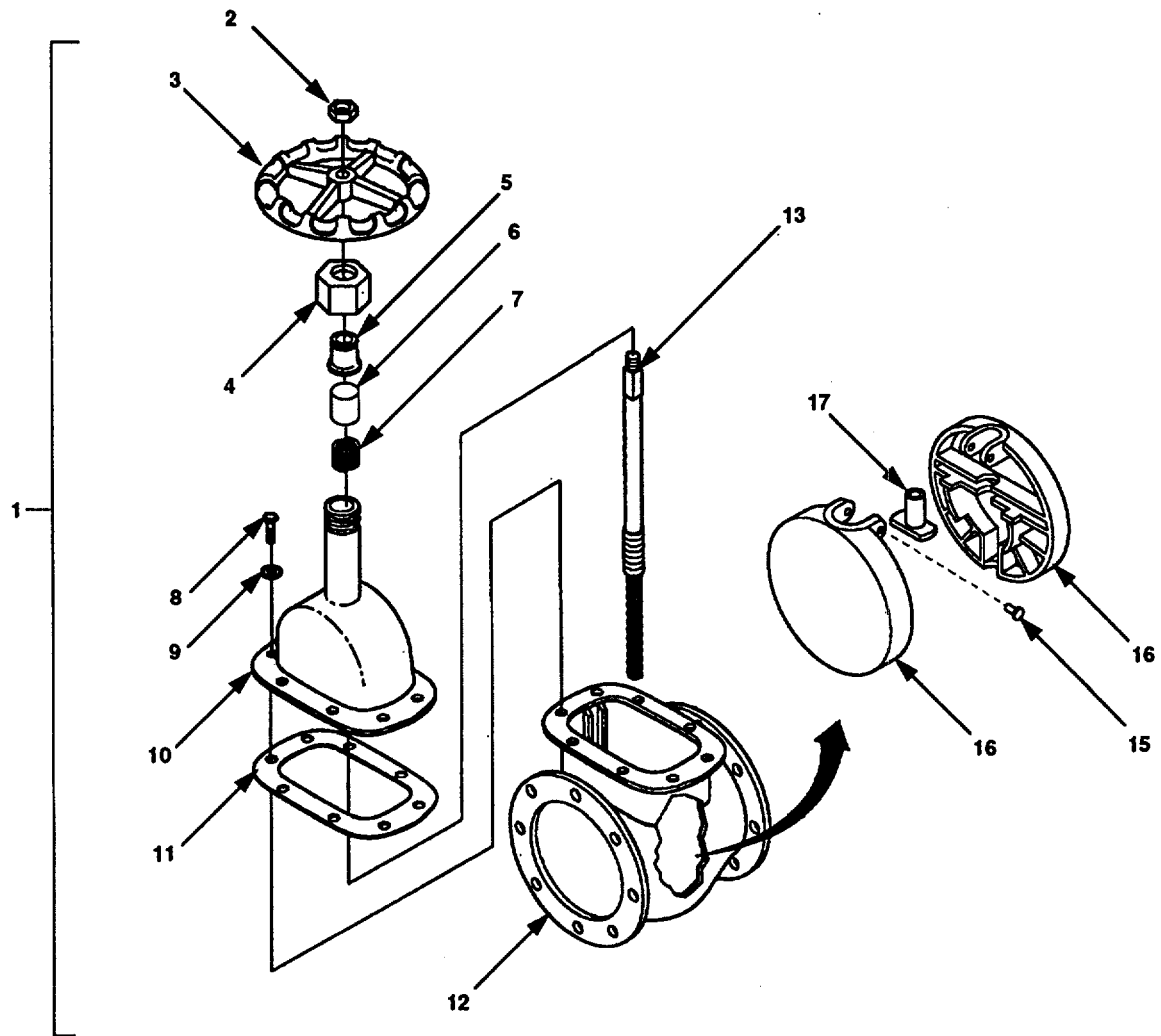


Figure 4-13. 4 Inch Gate Valve Assembly Maintenance.

4.12.1.5 Assembly.

- a. Position two discs (15 and 16) on pull nut (17).
- b. Install two screws (14) in discs (15 and 16).
- c. Install disc assembly (14) on valve stem (13).
- d. Screw valve stem (13) into bonnet (10).
- e. install new gasket (11) and bonnet (10) on valve body (12).
- f. Ensure mounting holes in bonnet (10), gasket (11) and valve body (12) are aligned.
- g. Install eight new lock washers (9) and screws (8). Tighten screws (8).
- h. Insert new packing (6) in bonnet (10).
- i. Install spring (7) and packing gland (5) on bonnet (10).
- j. Install packing nut (4) on stem of bonnet (10).
- k. Install handwheel (3) and nut (2) on stem of bonnet (10). Tighten nut (2).

4.12.1.6 Installation. Install 4 inch gate valve assembly (1) in accordance with paragraph 2.3.6.2.24

4.13 DISTRIBUTION POINT MAINTENANCE

4.13.1 Hypochlorination Unit, Model 1955-1 Replacement And Repair

This task covers:

- | | |
|---------------------|-----------------------|
| 4.13.1.1 Removal | 4.13.1.3 Repair |
| 4.13.1.2 Inspection | 4.13.1.4 Installation |

INITIAL SETUP

Tools

Tool Kit, General Mechanic's,
Automotive, Section III, Item 1,
Appendix B.

Equipment Conditions

Pumping station shutdown, refer to
applicable technical manual.

Equipment Conditions (Continued)

125 GPM pumping assembly shutdown, refer to
applicable technical manual.

General Safety Instructions

Do not work on equipment without following
standard shop safety precautions.

NOTE

This procedure is applicable to the model 1955-1 hypochlorination unit. The replacement of model 1955-3 and model A-506131 hypochlorination units are similar.

4.13.1.1 Removal. Placing the hypochlorination unit (Figure 4-14, 1) in the equipment conditions specified above will remove the hypochlorination unit (1) from the TWDS.

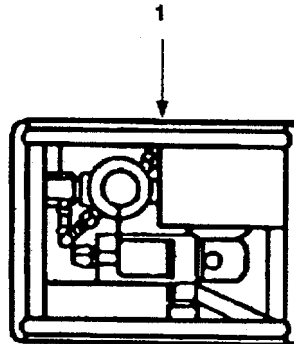


Figure 4-14. Hypochlorination Unit, Model 1955-1 Replacement.

4.13.1.2 Inspection. Inspect hypochlorination unit (1) for leaks, faulty operating components, or damage.

4.13.1.3 Repair. Replace damaged or defective hypochlorination unit (1).

4.13.1.4 Installation. Install hypochlorination unit (1) in accordance with paragraph 2.3.7.2.

4.13.2 Outlet, Pressure Regulator, Inlet, Drain, and Fill Hose Assemblies Maintenance.

This task covers:

4.13.2.1 Removal

4.13.2.2 Inspection

4.13.2.3 Installation

INITIAL SETUP**Tools**

Tool Kit, General Mechanic's,
Automotive, Section III, Item 1,
Appendix B

Material/Parts

Antiseize Tape, Item 9, Appendix E

Equipment Conditions

Hypochlorination Unit, Model 1955-1 removed,
refer to paragraph 4.13.1.

General Safety Instructions

Do not work on equipment without following
standard shop safety precautions.

4.13.2.1 Removal.**NOTE**

This procedure is applicable to the outlet hose assembly. The procedures for the pressure regulator, inlet, drain, and fill hose assemblies are similar.

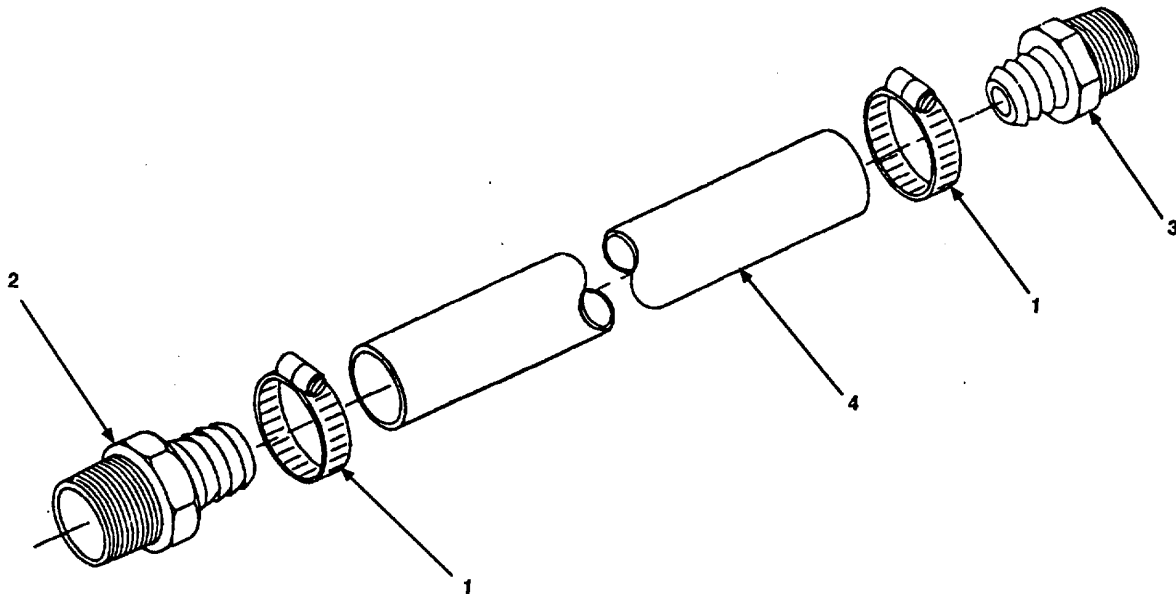


Figure 4-15. Outlet Hose Assembly Maintenance.

- a. Loosen two hose clamps (Figure 4-15, 1) and slide them back from hose connectors (2 and 3).
- b. Remove outlet hose (4) from hose connectors (2 and 3).
- c. Remove two hose clamps (1) from outlet hose (4).
- d. Remove hose connectors (2 and 3).

4.13.2 Outlet, Pressure-Regulator, Inlet, Drain, and-Fill Hose Assemblies Maintenance . (Continued)**4.13.2.2 Inspection.**

- a. Inspect two hose clamps (1) for corrosion, damage, and missing components.
- b. Inspect hose connectors (2 and 3) for corrosion, 6cracks, or damage.
- c. Inspect outlet hose (4) for holes, cracks, slices, tears, or damage.

4.13.2.3 Repair.

- a. Replace defective outlet hose (4) length.
- b. Replace defective or damaged hose clamps (1) and hose connectors (2 and 3).

4.13.2.4 Installation.**NOTE**

Wrap antiseize tape in direction of threads.

- a. Wrap antiseize tape around threads of hose connectors (2 and 3) and install hose connectors (2 and 3).
- b. Place two hose clamps (1) on replacement piece of outlet hose (4).
- c. Install outlet hose (4) on hose connectors (2 and 3).
- d. Slide two hose clamps (1) over outlet hose (4) and hose connectors (2 and 3) interface. Tighten hose clamps (1).

4.13.3 Pressure Gauge and Fill Assembly Replacement.

This task covers:

4.13.3.1 Removal

4.13.3.2 Inspection

4.13.3.3 Installation

INITIAL SETUP

Tools

Tool Kit, General Mechanic's,
Automotive, Section III, Item 1,
Appendix B

Material/Parts

Antiseize Tape, Item 9, Appendix E

Equipment Conditions

Hypochlorination Unit, Model 1955-1 removed,
refer to paragraph 4.13.1.

Fill Hose Assembly removed, refer to
paragraph 4.13.2.

General Safety Instructions

Do not work on equipment without following
standard shop safety precautions.

4.13.3.1 Removal.

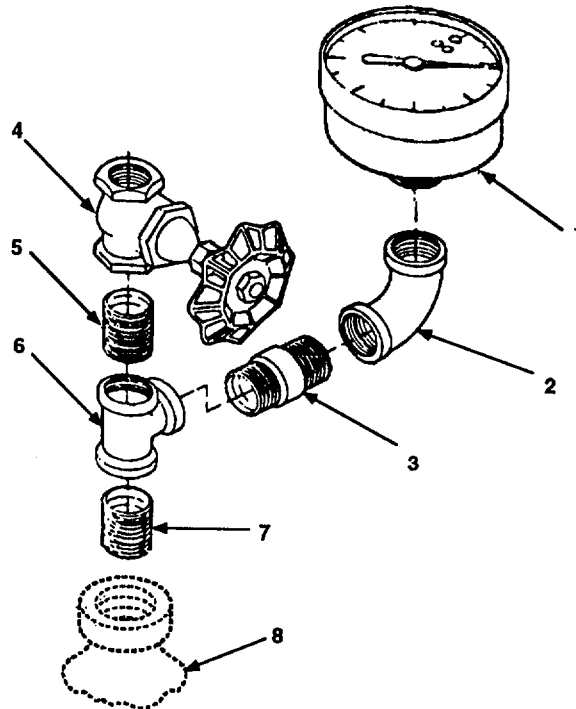


Figure 4-16. Pressure Gauge and Fill Assembly Maintenance.

- a. Remove pressure gauge (Figure 4-16, 1) from elbow (2).
- b. Remove elbow (2) from nipple (3).
- c. Remove globe valve (4) from close nipple (5).
- d. Remove close nipple (5) from pipe tee (6).
- e. Remove pipe tee (6) from close nipple (7).

4.13.3 Pressure Gauge and Fill Assembly Replacement. (Continued)

- f. Remove close nipple (7) from inlet nipple (8).

4.13.3.2 Inspection.

- a. Inspect pressure gauge (1) for cracked face, holes, or damage.
- b. Inspect globe valve (4) for corrosion, smooth operation of handle, cracks, holes, or damage.
- c. Inspect all piping hardware for corrosion, cracks, holes, bends, or damage.
- d. Replace all defective or damaged components.

4.13.3.3 Installation.**NOTE**

- Wrap all threaded portions of pressure gauge and fill assembly components with antiseize tape prior to installation.
 - Wrap antiseize tape in direction of threads.
- a. Install close nipple (7) on inlet nipple (8).
 - b. Install pipe tee (6) on close nipple (7).
 - c. Install close nipple (5) on pipe tee (6).
 - d. Install globe valve (4) on close nipple (5).
 - e. Install nipple (3) on pipe tee (6).
 - f. Install elbow (2) on nipple (3).
 - g. Install pressure gauge (1) on elbow (2).

4.13.4 Strainer Assembly Maintenance.

This task covers:

- | | |
|---------------------|-----------------------|
| 4.13.4.1 Removal | 4.13.4.3 Service |
| 4.13.4.2 Inspection | 4.13.4.3 Installation |

INITIAL SETUP

Tools

Tool Kit, General Mechanic's,
Automotive, Section III, Item 1,
Appendix B

Equipment Conditions

Hypochlorination Unit, Model 1955-1 removed,
refer to paragraph 4.13.1.

Inlet Hose Assembly removed, refer to
paragraph 4.13.2.

Material/Parts

Antiseize Tape, Item 9, Appendix E

General Safety Instructions

Do not work on equipment without following
standard shop safety precautions.

4.13.4.1 Removal.

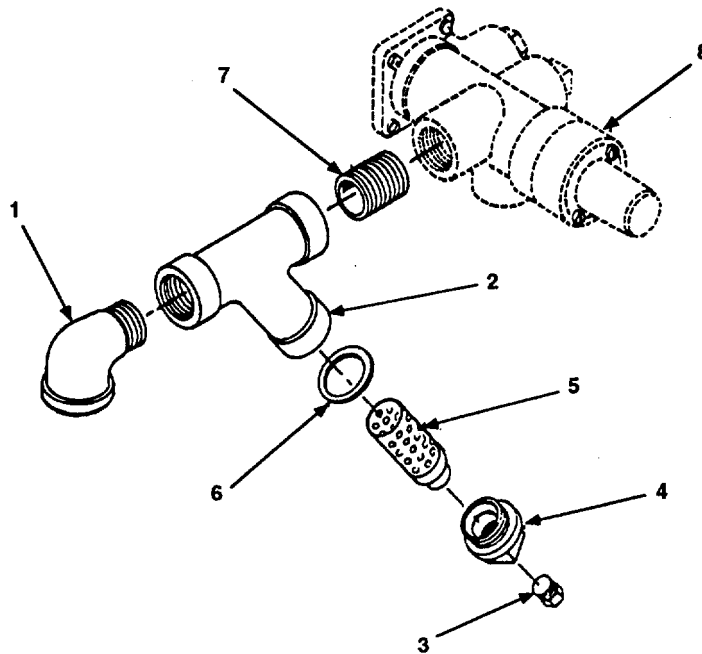


Figure 4-17. Strainer Maintenance.

- a. Remove street elbow (Figure 4-17, 1) from strainer body (2).
- b. Remove pipe plug (3) from strainer cap (4) and allow water to drain from strainer body (2).
- c. Remove strainer cap (4) from strainer body (2).
- d. Remove strainer screen (5) and gasket (6).

4.13.4 Strainer Assembly Maintenance. (Continued)

- e. Remove strainer body (2) from close nipple (7).
- f. Remove close nipple (7) from pilot valve assembly (8).

4.13.4.2 Inspection.

- a. Inspect street elbow (1), strainer body (2), strainer cap (4), strainer screen (5), and close nipple (7) for corrosion, cracks, bends, or damage.
- b. Inspect pipe plug (3) for corrosion or damage.
- c. Replace all defective or damaged components.

4.13.4.3 Service. Service consists of scrubbing down and rinsing off strainer screen (5), weekly.

4.13.4.4 Installation.**NOTE**

- Wrap all threaded portions of pressure gauge and fill assembly components with antiseize tape prior to installation.
 - Wrap antiseize tape in direction of threads.
- a. Install close nipple (7) in pilot valve assembly (8).
 - b. Install strainer body (2) on close nipple (7).
 - c. Install gasket (6) and strainer screen (5) in strainer body (2).
 - d. Install strainer cap (4) in strainer body (2).
 - e. Insert pipe plug (3) in strainer cap (4). Tighten pipe plug (3).
 - f. Install street elbow (1) on strainer body (2).

4.13.5 Water Meter and Gear Box Assembly Replacement.

This task covers:

4.13.5.1 Removal

4.13.5.2 Inspection

4.13.5.3 Installation

INITIAL SETUP

Tools

Tool Kit, General Mechanic's,
Automotive, Section III, Item 1,
Appendix B

Material/Parts

Antiseize Tape, Item 9, Appendix E

Lock washers (TM 10-4320-303-23P)

Equipment Conditions

Hypochlorination Unit, Model 1955-1 removed,
refer to paragraph 4.13.1.

Inlet, Outlet, Drain, and Discharge Hose
Assemblies removed, refer to paragraph
4.13.2.

Strainer Assembly removed, refer to
paragraph 4.13.4.

General Safety Instructions

Do not work on equipment without following
standard shop safety precautions.

4.13.5.1 Removal.

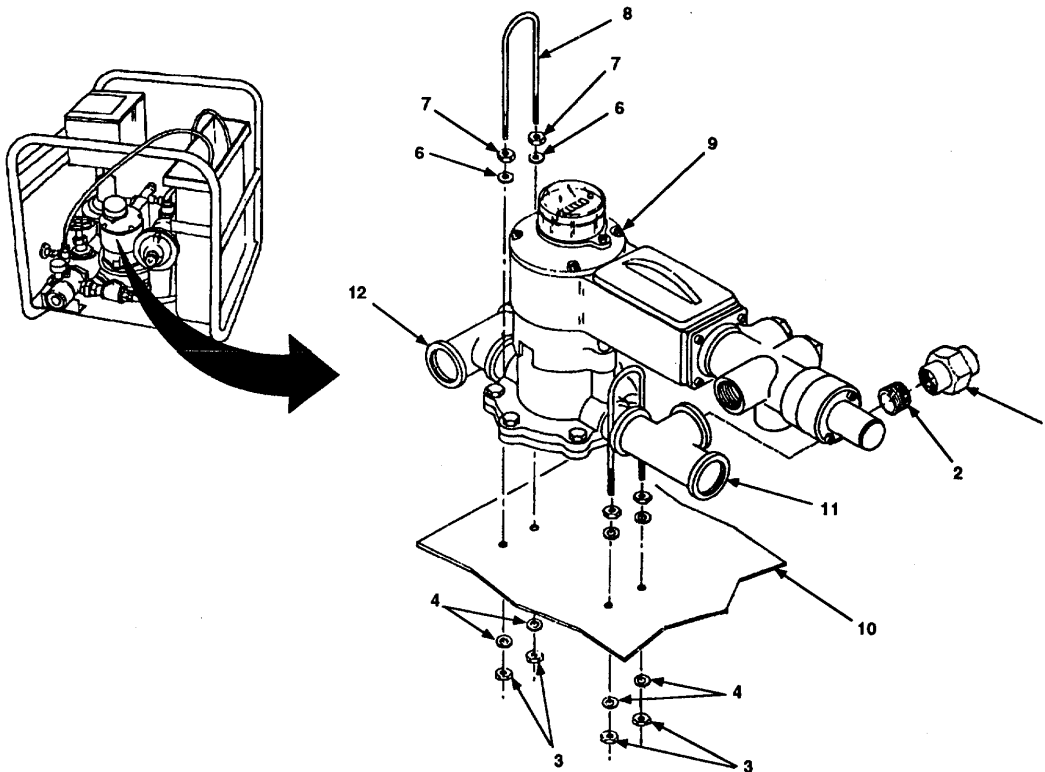


Figure 4-18. Water Meter and Gear Box Assembly Replacement.

4.13.5 Water Meter and Gear Box Assembly Replacement. (Continued)

- a. Loosen two unions (Figure 4-18, 1) from two close nipples (2).
- b. Remove four nuts (3), lock washers (4), and two u-bolts (5). Discard lock washers (4).
- c. Remove four flat washers (6) and nuts (7) from two u-bolts (8).
- d. Remove water meter and gear box assembly (9) from hypochlorination unit (10).
- e. Remove two close nipples (2) from pipe tees (11 and 12).
- f. Remove two pipe tees (11 and 12) from water meter and gear box assembly (9).

4.13.5.2 Inspection.

- a. Inspect water meter and gear box assembly (9) for corrosion, leaks, cracks, missing components, or damage. Notify direct support maintenance if water meter and gear box assembly (9) is damaged or defective.
- b. Inspect two close nipples (2) and pipe tees (11 and 12) for corrosion, cracks, holes, bends, or damage.
- c. Inspect mounting hardware for damage.
- d. Replace all defective components.

4.13.5.3 Installation.**NOTE**

- Wrap all threaded portions of pressure gauge and fill assembly components with antiseize tape prior to installation.
 - Wrap antiseize tape in direction of threads.
- a. Install two pipe tees (11 and 12) on water meter and gear box assembly (9).
 - b. Install two close nipples (2) in pipe tees (11 and 12).
 - c. Position water meter and gear box assembly (9) on hypochlorination unit (10) for installation.
 - d. Install four nuts (7) and flat washers (6) on two U-bolts (8).
 - e. Install two u-bolts (8) through hypochlorination unit (10) securing water meter and gear box assembly (9) to hypochlorination unit (10).
 - f. Install four new lock washers (4) and nuts (3) on two u-bolts (8). Tighten nuts (3) and (7).
 - g. Insert two close nipples (2) in two unions (1). Tighten unions (1) until water meter and gear box assembly (9) is firmly secured to hypochlorination unit (10).

4.13.6 Hypochlorinator Assembly Maintenance.

This task covers:

- | | |
|----------------------|-----------------------|
| 4.13.6.1 Removal | 4.13.6.4 Repair |
| 4.13.6.2 Disassembly | 4.13.6.5 Assembly |
| 4.13.6.3 Inspection | 4.13.6.6 Installation |

INITIAL SETUPTools

Tool Kit, General Mechanic's,
Automotive, Section III, Item 1,
Appendix B

Material/Parts

Lock washers (TM 10-4320-303-23P)
Preformed packing (TM 10-4320-303-23P)

Equipment Conditions

Hypochlorination Unit, Model 1955-1 removed,
refer to paragraph 4.13.1.

Outlet Hose Assembly removed, refer to
paragraph 4.13.2.

General Safety Instructions

Do not work on equipment without following
standard shop safety precautions.

4.13.6.1 Removal.

- a. Unscrew and remove discharge tube (Figure 4-19, 1) from liquid head (2).
- b. Remove check valve (3) and washer (4).
- c. Unscrew other end of discharge tube (1) and remove from hypochlorination unit.
- d. Unscrew and remove suction tube (5) from liquid head (2).
- e. Remove check valve (6) and washer (7).
- f. Remove three nuts (8), lock washers (9), flat washers (10), and bolts (11). Discard lock washers (9).
- g. Remove hypochlorinator frame (12) from hypochlorination unit.

4.13.6.2 Disassembly.

- a. Turn stroke adjust knob (13) fully counterclockwise and remove stroke adjust knob (13) from diaphragm cap (14).
- b. Remove preformed packing (15) from stroke adjust knob (13). Discard preformed packing (15).

WARNING

Items in hypochlorinator assembly are under spring tension. Maintain pressure on and slowly back diaphragm cap out to release spring pressure. Failure to obey this warning may result in personal injury.

- c. Remove four screws (16), flat washers (17), and square nuts (18).
- d. Slowly remove diaphragm cap (14).
- e. Remove nut (19) and washer (20) from pushrod (21).
- f. Remove impulse diaphragm (22), diaphragm clamping washer (23), spring spacer (24), spring (25), and preformed packing (26) from pushrod (21). Discard preformed packing (26).

4.13.6 Hypochlorinator Assembly Maintenance. (Continued)

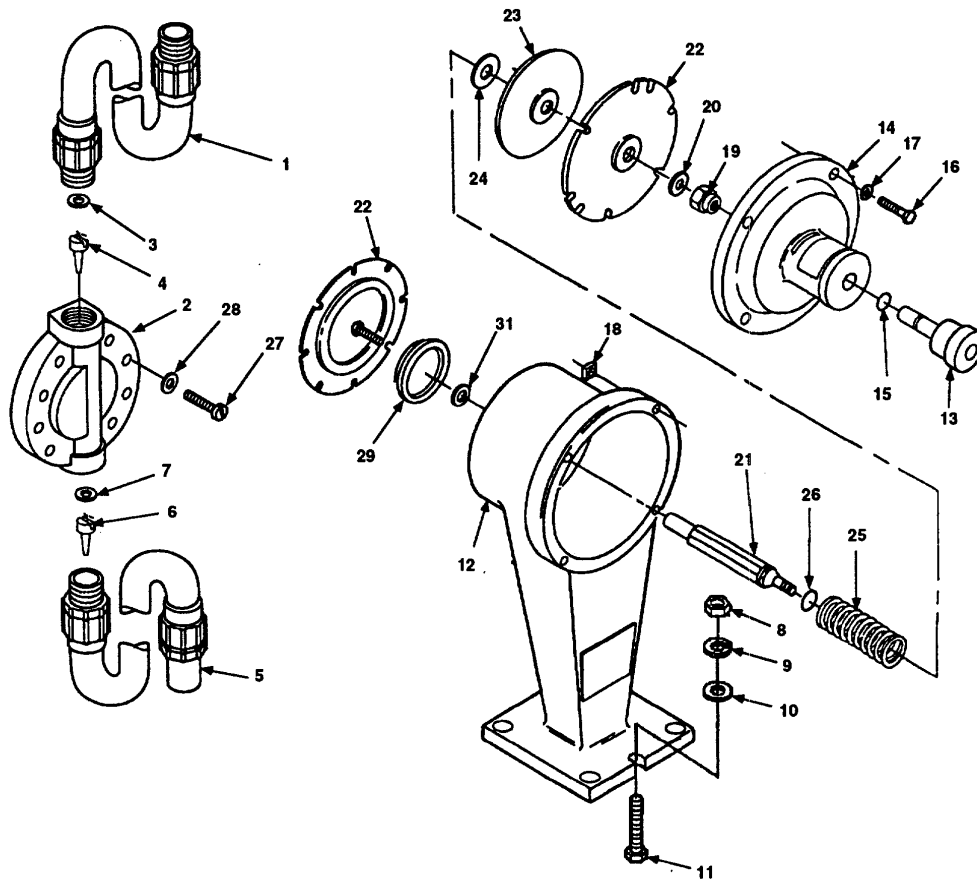


Figure 4-19. Hypochlorinator Assembly Maintenance.

- g. Remove eight screws (27) and lock washers (28). Discard lock washers (28).
- h. Remove liquid head (2) from hypochlorinator frame (12).
- i. Remove liquid head pushplate (29), diaphragm (30), and flat washer (31) from pushrod (21).
- j. Remove pushrod (21) from hypochlorinator frame (12).

4.13.6.3 **Inspection.**

- a. Inspect discharge tube (1) and suction tubes (2) for slice, cracks, holes, tears, or damage.

- b. Inspect hypochlorinator frame (12), stroke adjustment knob (13), diaphragm cap (14), push rod (21), impulse diaphragm (22), diaphragm clamping washer (23), spring (25), liquid head pushplate (29), and diaphragm (30) for corrosion, cracks, bends, or damage.
- c. Inspect check valves (3) and washers (4) for damage.
- d. Inspect all mounting hardware and washers for corrosion or damage. 4.13.6.4 Repair. Repair of the hypochlorinator assembly consists of replacing defective or damaged components.

4.13.6.5 Assembly.

- a. Insert pushrod (21) into hypochlorinator frame (12).
- b. Install flat washer (31), diaphragm (30), and liquid head pushplate (29) on pushrod (21).
- c. Install liquid head (2) on hypochlorinator frame (12).
- d. Align mounting holes of liquid head (2) with mounting holes of hypochlorinator frame (12).
- e. Install eight new lock washers (28) and screws (27). Tighten screws (27).
- f. Install new preformed packing (26), spring (25), spring spacer (24), diaphragm clamping washer (23), and impulse diaphragm (22) on pushrod (21).
- g. Install washer (20) and nut (19) on pushrod (21). Tighten nut (19).
- h. Install diaphragm cap (14) on hypochlorinator frame (12) and align mounting holes of diaphragm cap (14) with mounting holes on hypochlorinator frame (12).
- i. Install four square nuts (18), flat washers (17), and screws (16). Tighten screws (16).
- j. Install new preformed packing (15) on stroke adjust knob (13).
- k. Insert stroke adjust knob (13) into diaphragm cap (14). Turn stroke adjustment knob (13) right one full turn.

4.13.6.6 Installation.

- a. Align mounting slots of hypochlorinator frame (12) with mounting holes on hypochlorination unit.
- b. Install three bolts (11), flat washers (10), new lock washers (9), and nuts (8). Tighten nuts (8).
- c. Insert washer (7) and check valve (6) into liquid head (2).
- d. Install suction tube (5) into liquid head (2).
- e. Install discharge tube (1) on hypochlorination unit.
- f. Insert washer (4) and check valve (3) into liquid head (2).
- g. Install discharge tube (1) into liquid head (2).

4.13.7 Manifold Assembly Maintenance And Pressure Regulator Valve Replacement.

This task covers:

- | | |
|----------------------|-----------------------|
| 4.13.7.1 Removal | 4.13.7.4 Repair |
| 4.13.7.2 Disassembly | 4.13.7.5 Assembly |
| 4.13.7.3 Inspection | 4.13.7.6 Installation |

INITIAL SETUP

Tools

Tool Kit, General Mechanic's,
Automotive, Section III, Item 1,
Appendix B

Material/Parts

Antiseize Tape, Item 9, Appendix E

Lock washers (TM 10-4320-303-23P)

Equipment Conditions

Hypochlorination Unit, Model 1955-1
removed, refer to paragraph 4.13.1.

Equipment Conditions (Continued)

Pressure Hose Assembly removed, refer to
paragraph 4.13.2.

Pressure Gauge and Fill Assembly removed,
refer to paragraph 4.13.3.

Water Meter and Gear Box Assembly
disconnected from unions, refer to paragraph
4.13.5.

General Safety Instructions

Do not work on equipment without following
standard shop safety precautions.

4.13.7.1 Removal.

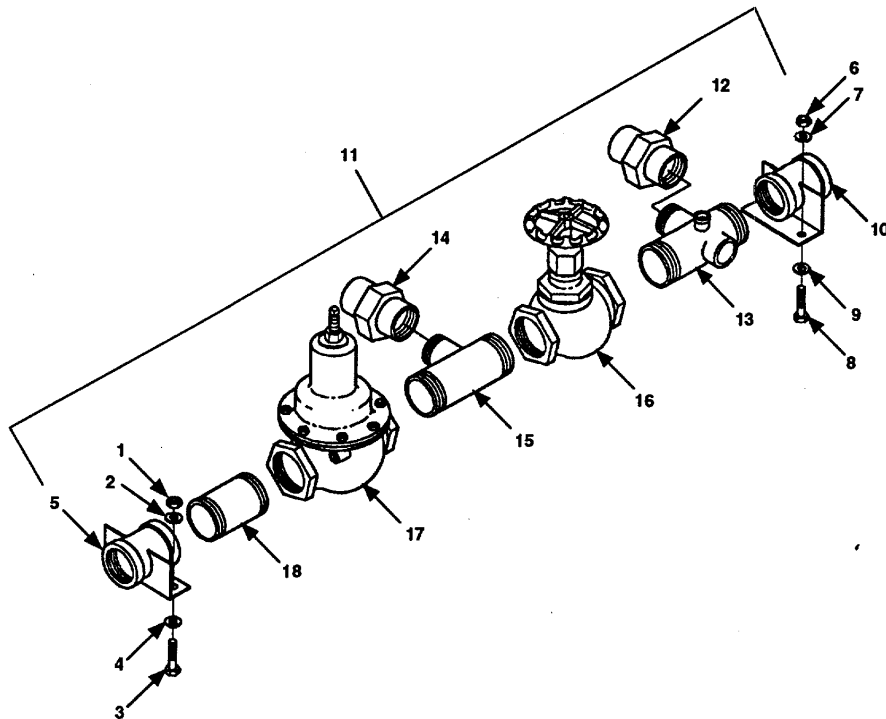


Figure 4-20. Manifold Assembly Maintenance

- a. Remove two nuts (Figure 4-20, 1) lock washers (2), bolts (3) and flat washers (4) from outlet support coupling (5). Discard lock washers (2).
- b. Remove two nuts (6), lock washers (7), bolts (8), and flat washers (9) from inlet support coupling (10). Discard lock washers (7).
- c. Remove manifold assembly (11) from hypochlorination unit.

4.13.7.2 Disassembly.

- a. Unscrew and remove union (12) from inlet nipple (13).
- b. Unscrew and remove union (14) from outlet nipple (15).
- c. Remove inlet support coupling (10) from inlet nipple (13).
- d. Remove inlet nipple (13) from 2 inch globe valve assembly (16).
- e. Remove 2 inch globe valve assembly (16) from outlet nipple (15).
- f. Remove outlet nipple (15) from pressure regulating valve (17).
- g. Remove pressure regulating valve (17) from pipe nipple (18).
- h. Remove pipe nipple (18) from outlet support coupling (5).

4.13.7.3 Inspection.

- a. Inspect outlet support coupling (5), inlet support coupling (10), unions (12 and 14), inlet nipple (13), outlet nipple (15), and pipe nipple (18) for corrosion, cracks, holes, or damage.
- b. Inspect 2 inch globe valve (16) and pressure regulating valve (17) for leaks, cracks, holes, missing components, or damage. Notify direct support if pressure regulator valve (17) is damaged or defective.
- c. Inspect all mounting hardware for damage.

4.13.7.4 Repair. Repair of manifold assembly (11) consists of replacing damaged or defective components.

4.13.7.5 Assembly.

NOTE

- Wrap all threaded portions of pressure gauge and fill assembly components with antiseize tape prior to installation.
 - Wrap antiseize tape in direction of threads.
- a. Install pipe nipple (18) in outlet coupling support (5).
 - b. Install pressure regulating valve (17) on pipe nipple (18).
 - c. Install outlet nipple (15) in pressure regulating valve (17).
 - d. Install union (14) on outlet nipple (15).
 - e. Install 2 inch globe valve assembly (16) on outlet nipple (15).
 - f. Install inlet nipple (13) in 2 inch globe valve assembly (16).
 - g. Install union (12) on inlet nipple (13).
 - h. Install inlet support coupling (10) on inlet nipple (13).

4.13.7 Manifold Assembly Maintenance And Pressure Regulator Valve Replacement. (Continued)

4.13.7.6 Installation.

- a. Place manifold assembly (11) in hypochlorination unit and align mounting holes of manifold assembly (11) with mounting holes of hypochlorination unit.
- b. Install two flat washers (9), bolts (8), new lock washers (7), and nuts (6) on inlet support coupling (10). Tighten nuts (6).
- c. Install two flat washers (4), bolts (3), new lock washers (2), and nuts (1) on outlet support coupling (5). Tighten nuts (1).

4.13.8 Frame Assembly Replacement.

This task covers:

- | | |
|----------------------|-------------------|
| 4.13.8.1 Removal | 4.13.8.4 Repair |
| 4.13.8.2 Disassembly | 4.13.8.5 Assembly |
| 4.13.8.3 Inspection | |
-

INITIAL SETUP

Tools

Tool Kit, General Mechanic's,
Automotive, Section III, Item 1,
Appendix B

Material/Parts

Reservoir (TM 10-4320-303-23p)
Toolbox (TM 10-4320-303-23P)
Lock washers (TM 10-4320-303-23P)

Equipment Conditions

Hypochlorination Unit, Model 1955-1
removed, refer to paragraph 4.13.1.

Equipment Conditions (Continued)

Outlet, Pressure Regulator, Inlet, Drain,
and Fill Hose Assemblies removed, refer to
paragraph 4.13.2.

Pressure Gauge and Fill Assembly removed,
refer to paragraph 4.13.3.

Strainer removed, refer to paragraph 4.13.4.

Water Meter and Gear Box Assembly removed,
refer to paragraph 4.13.5.

Manifold Assembly removed, refer to
paragraph 4.13.7.

General Safety Instructions

Do not work on equipment without following
standard shop safety precautions.

4.13.8.1 Removal. Placing the frame assembly (Figure 4-21, 1) in the equipment conditions specified above will remove the frame assembly (1) from the hypochlorination unit.

4.13.8.2 Disassembly.

- a. Remove chlorine reservoir (1) from frame (2).
- b. Open top of tool box (3).
- c. Remove four nuts (4), lock washers (5), and screws (6). Discard lock washers (5).
- d. Remove tool box (3) from frame (2).

4.13.8.3 Inspection.

- a. Inspect chlorine reservoir (1) for cracks, holes, or damage.
- b. Inspect frame (2) for cracks, bends, or separation of welds.
- c. Inspect tool box (3) for smooth operation of top, corrosion, cracks, holes, or damage.
- d. Inspect mounting hardware for damage.

4.13.8.4 Repair.

- a. Replace damaged or defective chlorine reservoir (1) or tool box (3).
- b. Notify direct support if frame (2) is damaged or defective.

4.13.8 Frame Assembly Replacement. (Continued)

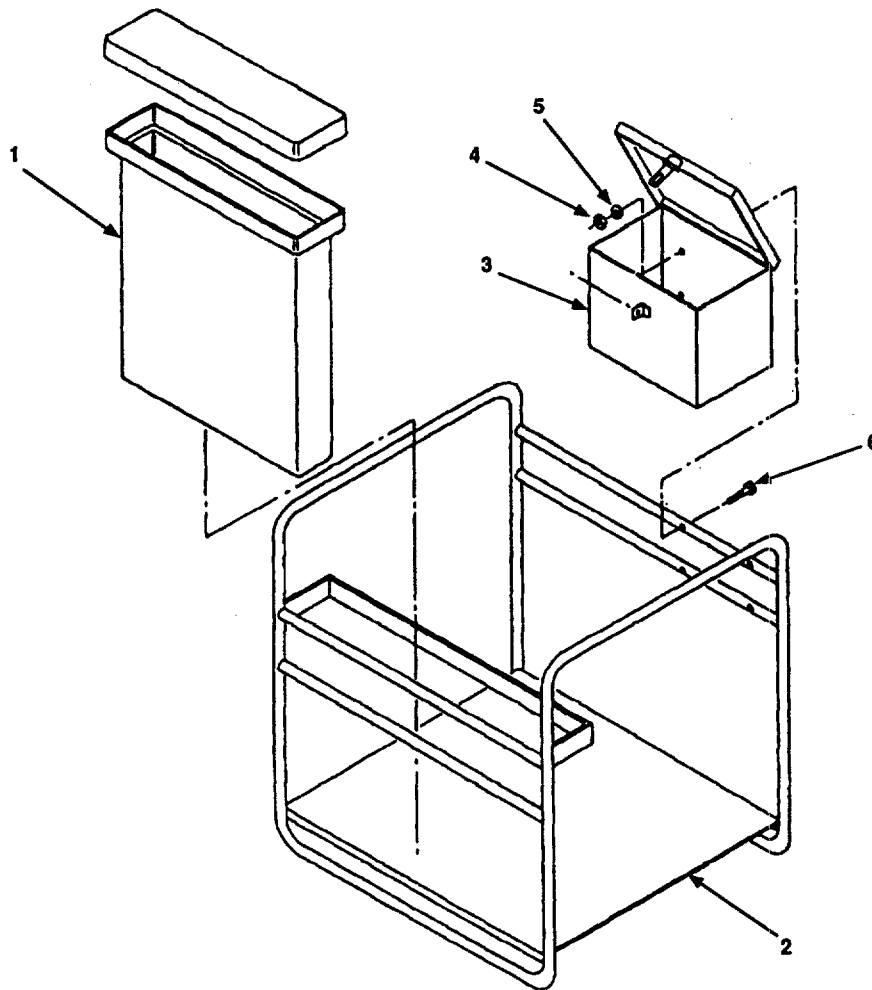


Figure 4-21. Chlorine Reservoir and Tool Box Replacement.

- c. Replace all damaged mounting hardware.

4.13.8.5 Assembly.

- a. Align mounting holes of tool box (3) and frame (2).
- b. Install four screws (6), new lock washers (5), and nuts (4). Tighten nuts (4).
- c. Close top of tool box (3).
- d. Insert chlorine reservoir (1) in frame (2).

4.13.9 Stand Assembly Maintenance.

This task covers:

- | | |
|----------------------|-------------------|
| 4.13.9.1 Disassembly | 4.13.9.3 Repair |
| 4.13.9.2 Inspection | 4.13.9.4 Assembly |

INITIAL SETUP

Tools

Tool Kit, General Mechanic's,
Automotive, Section III, Item 1,
Appendix B

Equipment Conditions

Nozzles and Elbow Coupler Valves removed
from stand.

General Safety Instructions

Do not work on equipment without following
standard shop safety precautions.

Material/Parts

Cotter Pins (TM 10-4320-303-23P)

4.13.9.1 Disassembly.

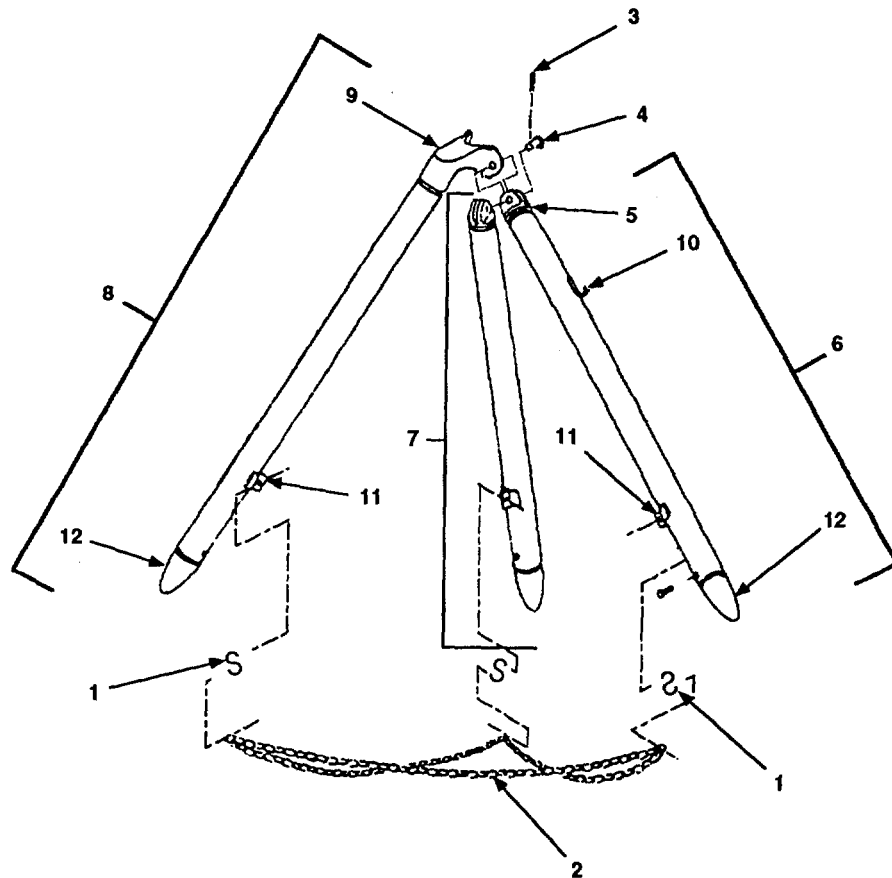


Figure 4-22. Stand Assembly Maintenance.

- a. Remove three S-hooks (Figure 4-22, 1).
- b. Remove three chains (2) from three S-hooks (1).
- c. Remove two cotter pins (3) from two straight pins (4). Discard cotter pins (3).

4.13.9 Stand Assembly Maintenance. (Continued)

- d. Remove two straight pins (4) from two devises (5).
- e. Separate two clevis legs (6 and 7) from pivot leg (8).

4.13.9.2 Inspection.

- a. Inspect two clevis legs (6 and 7) and pivot leg (8) for missing or damaged devises (5), pivot (9), hooks (10), clips (11), and plugs (12) or separated or cracked welds.
- b. Inspect three S-hooks (1) for corrosion, cracks, or nicks.
- c. Inspect three chains (2) for damaged or missing links.

4.13.9.3 Repair.

- a. Refer to Appendix F and manufacture new chain.
- b. Replace damaged or missing components.

4.13.9.4 Assembly.

- a. Align two clevis legs (6 and 7) in pivot (9).
- b. Install two straight pins (4) through two devises (5).
- c. Install two new cotter pins (3) in two straight pins (4). Bend tines of cotter pins (3).
- d. Install three chains (2) in three S-hooks (1).
- e. Install three S-hooks (1) on pivot leg (8) and two clevis legs (6 and 7).

4.13.10 Color Comparator Maintenance.

This task covers:

4.13.10.1 Disassembly

4.13.10.3 Repair

4.13.10.2 Inspection

4.13.10.4 Assembly

INITIAL SETUP**Tools**

Tool Kit, General Mechanic's,
Automotive, Section III, Item 1,
Appendix B

General Safety Instructions

Do not work on equipment without following
standard shop safety precautions.

Equipment Conditions

Color Comparator removed from color
comparator kit.

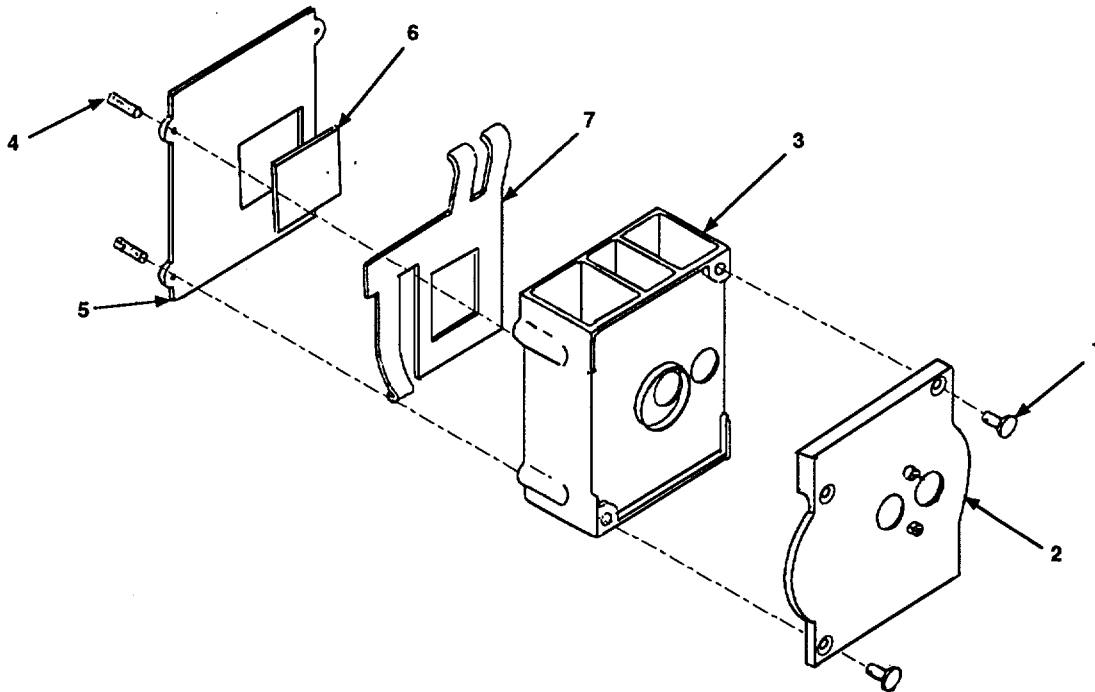
4.13.10.1 Disassembly.

Figure 4-23. Color Comparator Maintenance.

- a. Remove two front cover screws (Figure 4-23, 1).
- b. Remove front cover (2) from comparator body (3).
- c. Remove four back cover screws (4).
- d. Remove back cover assembly (5) from comparator body (3).

4.13.10 Color Comparator Maintenance. (Continued)**4.13.10.2 Inspection.**

- a. Inspect front cover (2) and comparator body (3) for cracks, holes, or damage.
- b. Inspect back cover assembly (5) for cracks, holes, broken or missing diffusing glass (6), or damaged spring (7).
- c. Inspect mounting hardware for damage.

4.13.10.3 Repair. Repair of the color comparator consists of replacing damaged or defective components. If diffusing glass (6) or spring (7) is damaged replace back cover assembly (5).

4.13.10.4 Assembly.

- a. Align mounting holes of back cover assembly (5) with mounting holes of comparator body (3).
- b. Install four back cover screws (4). Tighten screws (4).
- c. Align mounting holes of front cover (2) with mounting holes of comparator body (3).
- d. Install two front cover screws (1). Tighten screws (1).
- e. Place color comparator in color comparator kit.

4.14 SUSPENSION KIT MAINTENANCE.

This task covers:

4.14.1 Inspect

4.14.2 Repair

4.14.3 Replace

INITIAL SETUP

Tools

Tool Kit, General Mechanic's,
Automotive, Section III, Item 1,
Appendix B

General Safety Instructions

Do not work on equipment without following
standard shop safety precautions.

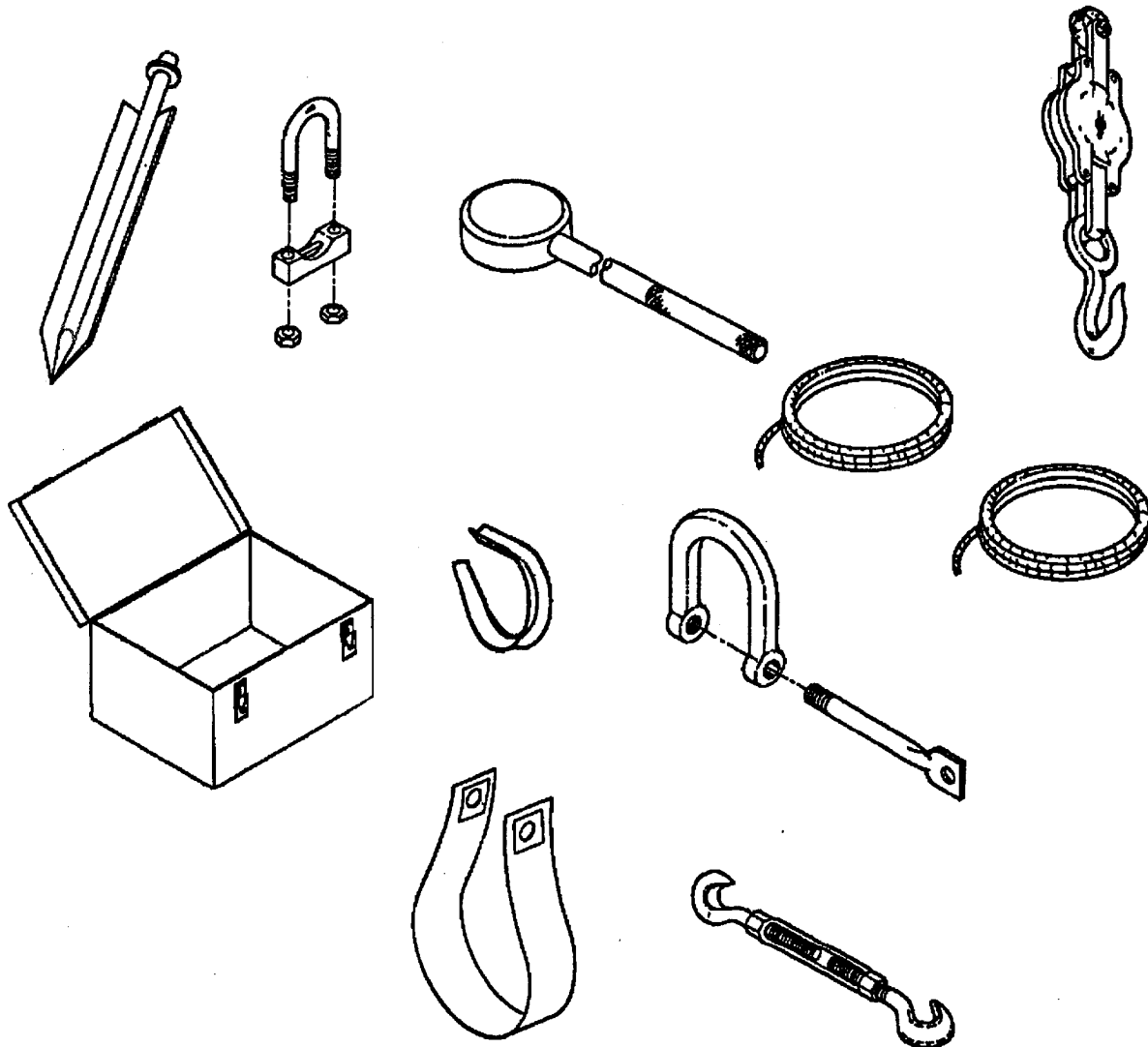


Figure 4-24. Suspension Kit Components.

4.14 SUSPENSION KIT MAINTENANCE. (Continued)

4.14.1 Inspect.

- a. Inspect kit for presence of all components as detailed in Components of End Item, Appendix C.
- b. Inspect chest and all components for damage.

4.14.2 Repair. Repair of the suspension kit consists of replacing missing or damaged components.

4.14.3 Replace. Replace suspension kit if either the chest is damaged or more than half of the suspension kit components are damaged or missing.

4.15 DISPLACEMENT AND EVACUATION KIT MAINTENANCE.

This task covers:
 4.15.1 Inspect
 4.15.2 Repair

4.15.3 Replace

INITIAL SETUP

Tools

Tool Kit, General Mechanic's,
 Automotive, Section III, Item 1,
 Appendix B

General Safety Instructions

Do not work on equipment without following
 standard shop safety precautions.

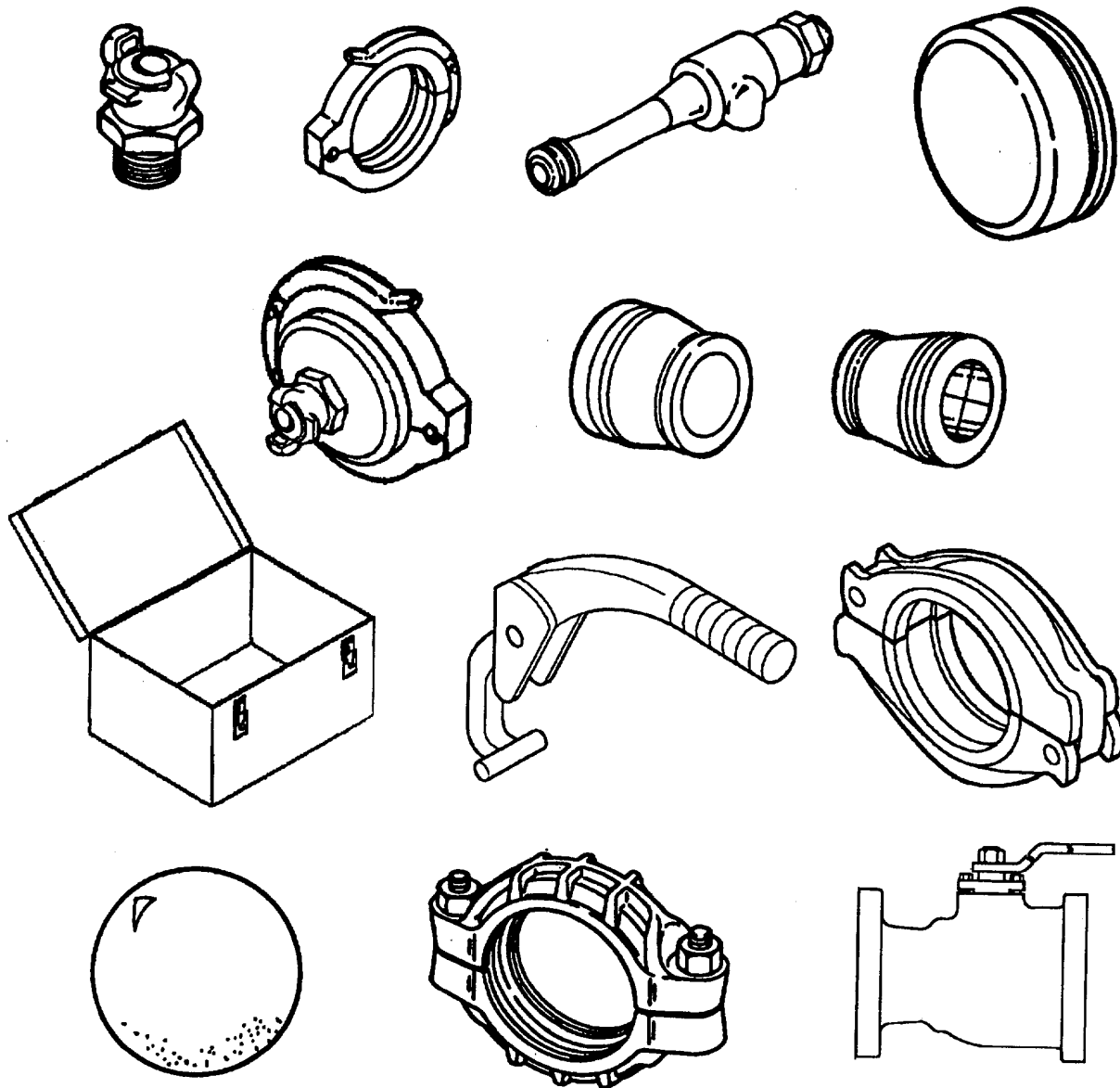


Figure 4-25. Displacement and Evacuation Kit Components.

4.15 DISPLACEMENT AND EVACUATION KIT MAINTENANCE. (Continued)

4.15.1 Inspect.

- a. Inspect kit for presence of all components as detailed in Components of End Item, Appendix C.
- b. Inspect chest and all components for damage.

4.15.2 Repair. Repair of the displacement and evacuation kit consists of replacing missing or damaged components.

4.15.3 Replace. Replace displacement and evacuation kit if either the chest is damaged or more than half of the displacement and evacuation kit components are damaged or missing.

4.16 PACKING KIT MAINTENANCE.

This task covers:

4.16.1 Inspect

4.16.2 Repair

4.16.3 Replace

INITIAL SETUP

Tools

Tool Kit, General Mechanic's,
Automotive, Section III, Item 1,
Appendix B

General Safety Instructions

Do not work on equipment without following
standard shop safety precautions.

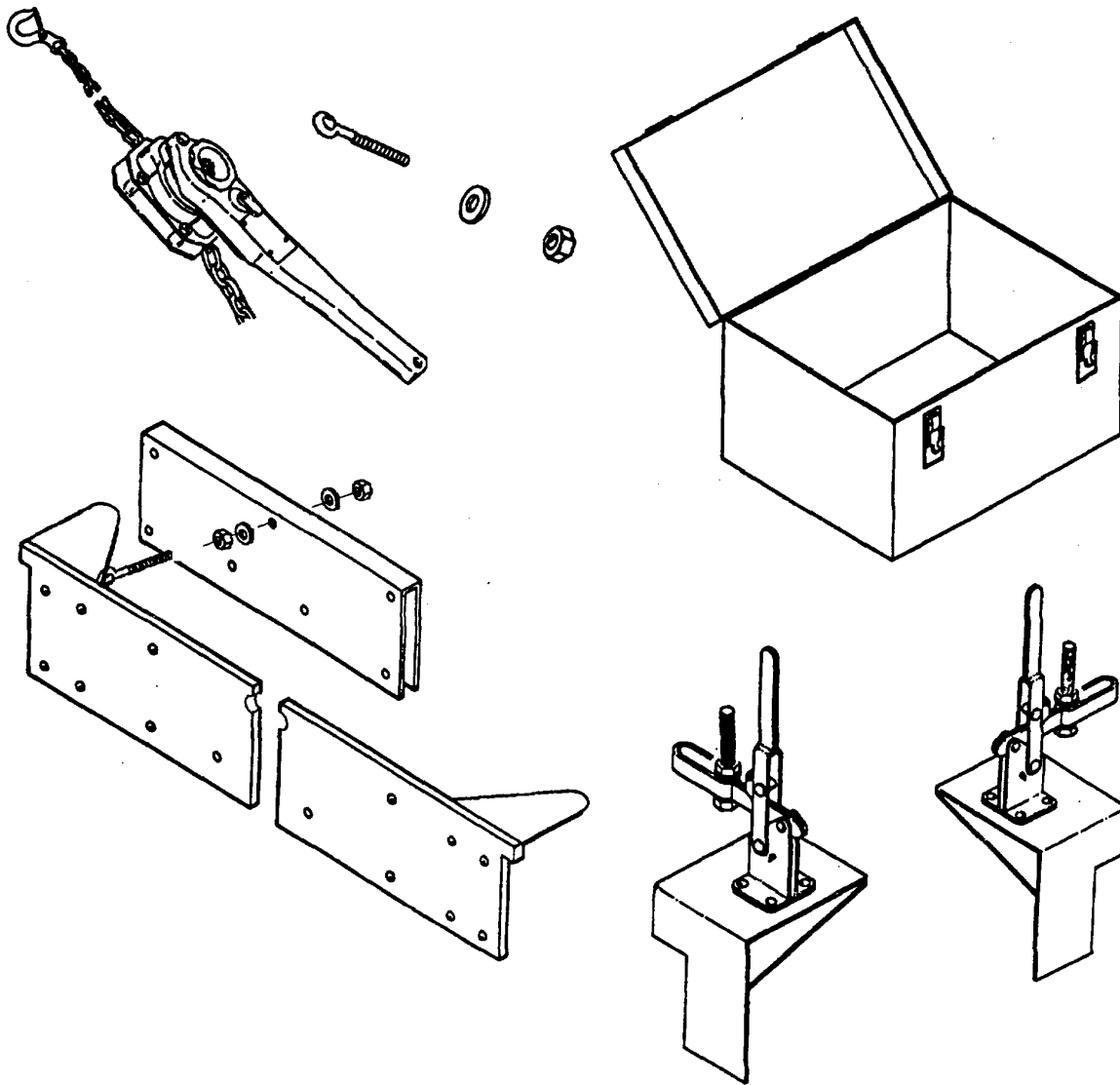


Figure 4-26. Packing Kit Components.

4.16 PACKING KIT MAINTENANCE. (Continued)

4.16.1 Inspect.

- a. Inspect kit for presence of all components as detailed in Components of End Item, Appendix C.
- b. Inspect chest and all components for damage.

4.16.2 Repair.

- a. Repair of the packing kit consists of replacing missing or damaged components.
- b. For repair to a damaged hose retaining bracket refer to paragraph 4.16.1, Hose Retaining Bracket Maintenance.

4.16.3 Replace. Replace packing kit if either chest is damaged or more than half of the packing kit components are damaged or missing.

4.16.1 Hose Retaining Bracket Maintenance.

This task covers:

- 4.16.1.1 Disassembly
- 4.16.1.2 Inspection

- 4.16.1.3 Repair
 - 4.16.1.4 Assembly
-

INITIAL SETUP

Tools

Tool Kit, General Mechanic's,
Automotive, Section III, Item 1,
Appendix B

General Safety Instructions

Do not work on equipment without following
standard shop safety precautions.

Equipment Conditions

Hose Retaining Bracket removed from
packing kit.

4.16.1.1 Disassembly.

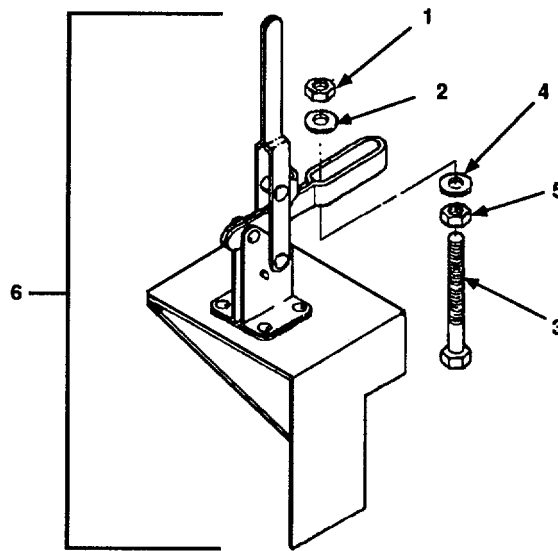


Figure 4-27. Hose Retaining Bracket Maintenance.

NOTE

This procedure is applicable to both the right and left hose retaining bracket.

- a. Remove nut (Figure 4-27, 1) and flat washer (2).
- b. Remove bolt (3), flat washer (4), and nut (5).

4.16.1.2 Inspection.

- a. Inspect hose retaining bracket (6) for separation of welds, cracks, damaged or missing toggle. Notify direct support maintenance if hose retaining bracket (6) is damaged.
- b. Inspect nuts (1 and 5), flat washers (2 and 4), and bolt (3) for damage.

4.16.1 Hose Retaining Bracket Maintenance. (Continued)

4.16.1.3 Repair. Repair of hose retaining bracket assembly consists of replacing defective or damaged components.

4.16.1.4 Assembly.

- a. Install nut (5) and flat washer (4) on bolt (3).
- b. Install bolt (3) on hose retaining bracket (6).
- c. Install flat washer (2) and nut (1). Tighten nut (1).
- d. Place hose retaining bracket in packing kit.

4.16.2 Pull Board Assembly Repair. Pull board assembly repair consists of replacing damaged or defective components.

4.17 REPAIR KIT MAINTENANCE.

This task covers:

- 4.17.1 Inspect
- 4.17.2 Repair

4.17.3 Replace

INITIAL SETUP

Tools

Tool Kit, General Mechanic's,
Automotive, Section III, Item 1,
Appendix B

General Safety Instructions

Do not work on equipment without following
standard shop safety precautions.

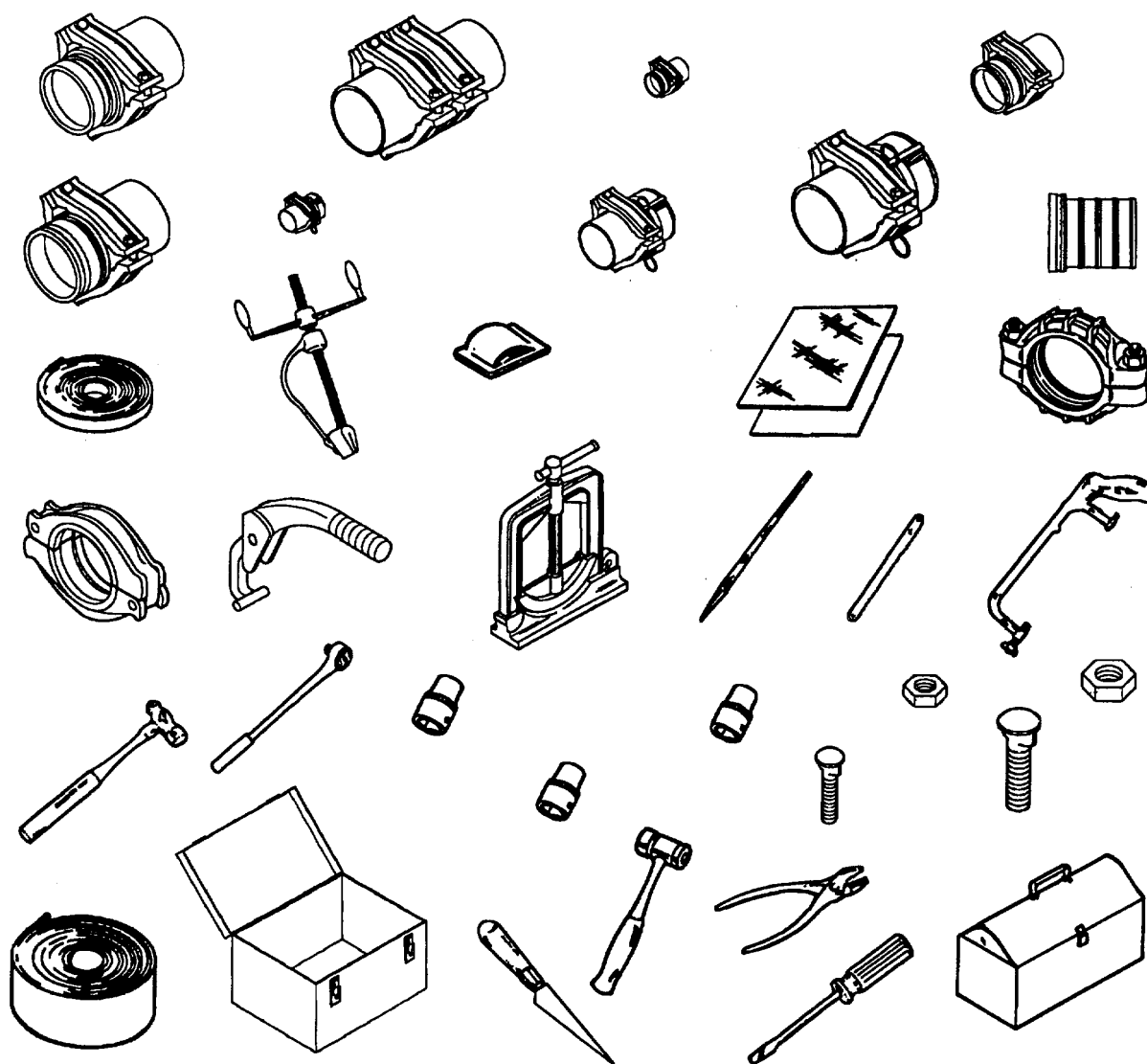


Figure 4-28. Repair Kit Components.

4.17 REPAIR KIT MAINTENANCE. (Continued)

4.17.1 Inspect.

- a. Inspect kit for presence of all components as detailed in Components of End Item, Appendix C.
- b. Inspect chest and all components for damage.

4.17.2 Repair. Repair of the repair kit consists of replacing damaged or missing items.

4.17.3 Replace. Replace repair kit if either the chest is damaged or more than half of the repair kit components are damaged or missing.

4.18 SLING ASSEMBLY MAINTENANCE.

This task covers:

- 4.18.1 Disassembly
- 4.18.2 Inspection

- 4.18.3 Repair
- 4.18.4 Assembly

INITIAL SETUP

Tools

Tool Kit, General Mechanic's,
Automotive, Section III, Item 1,
Appendix B

Equipment Conditions

There are no equipment conditions for this procedure.

Material/Parts

Lubricant, Item 6, Appendix E
Rags, Item 8, Appendix E

General Safety Instructions

Do not work on equipment without following standard shop safety precautions.

4.18.1 Disassembly.

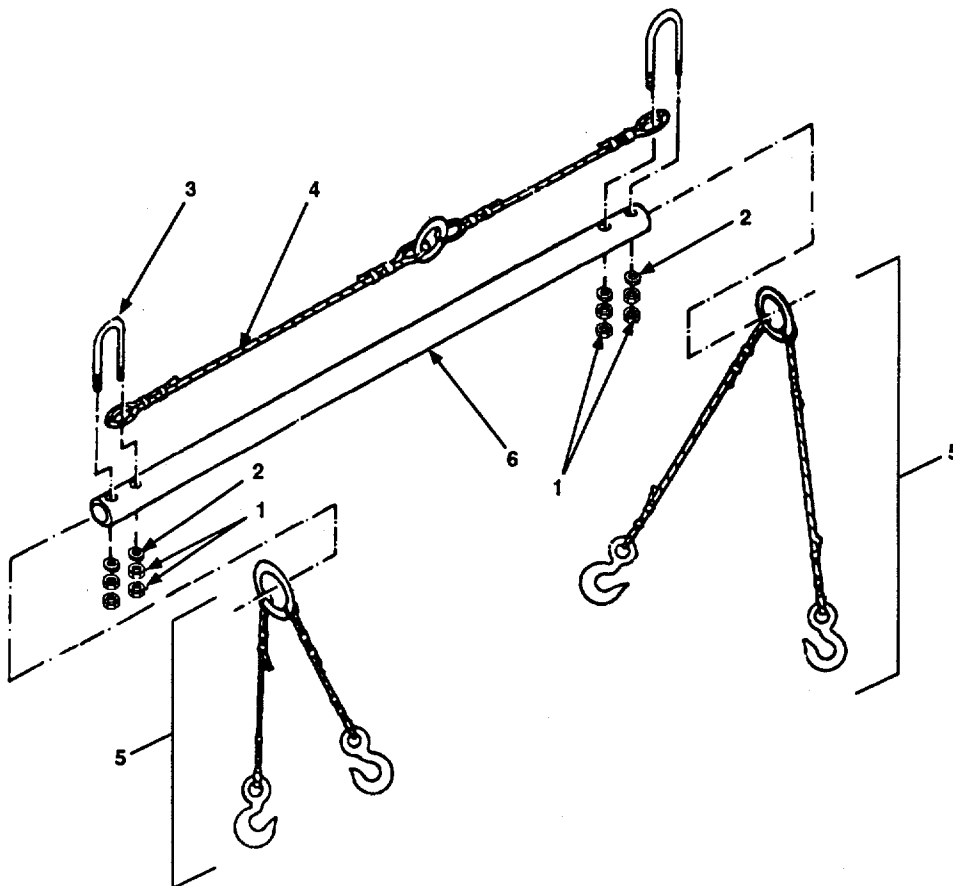


Figure 4-29. Sling Assembly Maintenance.

4.18 SLING ASSEMBLY MAINTENANCE. (Continued)

- a. Remove eight nuts (Figure 4-29, 1) and four flat washers (2).
- b. Remove two U-bolts (3).
- c. Remove 3/4 inch (1.9 cm) wire rope assembly (4), two 1/2 inch (1.3 cm) wire rope assemblies (5), and spreader bar (6).

4.18.2 Inspection.

- a. Inspect U-bolts (3) for distortion and worn or stripped threads.
- b. Carefully inspect 3/4 inch (1.9 cm) wire rope assembly (4) and two 1/2 inch (1.3 cm) wire rope assemblies (5) for loose splices, worn or broken wires, unraveled strands, and damaged thimbles.

CAUTION

To avoid damage to wire rope, make sure lubricant is free of acids and alkalis.

- c. Clean 3/4 inch (1.9 cm) wire rope assembly (4) and two 1/2 inch (1.3 cm) wire rope assemblies (5) of dirt, sand, and other abrasives. Using clean rag, swab rope with lubricant.
- d. Inspect eight nuts (1), four flat washers (2), spreader bar (6) for damage.

4.18.3 Repair. Repair consists of replacing damaged or defective components.

4.18.4 Assembly.

- a. Insert two U-bolts (3) through thimbles on each end of 3/4 inch (1.9 cm) wire rope assembly (4).
- b. Install two wire rope assemblies (5) on each end of spreader bar (6).
- c. Position two wire rope assemblies (5) between two holes on each end of spreader bar (6).
- d. Insert two U-bolts (3) through holes on each end of spreader bar (6), securing two wire rope assemblies (5) to spreader bar (6).
- e. Install two flat washers (2) and four nuts (1) on each U-bolt (3). Tighten nuts (1).

SECTION VI. PREPARATION FOR SHIPMENT AND STORAGE

4.19 PRESERVATION PROCEDURES.

Preservation procedures for the TWDS are contained in paragraphs 4.19.1 through 4.19.7.

4.19.1 TWDS Components Preservation.

- a. Clean all dirt, sand and debris from exterior surfaces of all TWDS components.
- b. Ensure all TWDS components are thoroughly dry prior to packing.

4.19.2 600 GPM Pumping Assemblies Preservation. Refer to applicable technical manual for preservation procedures for the 600 GPM pumping assemblies.

4.19.3 20,000 Gallon Pillow Tank Preservation. Refer to applicable technical manual for preservation procedures for the 20,000 gallon pillow tank.

4.19.4 125 GPM Pumping Assembly Preservation. Refer to applicable technical manual for preservation procedures for the 125 GPM pumping assembly.

4.19.5 Hypochlorination Unit, Model 1955-1 Preservation .

- a. Clean and rinse reservoir with water.
- b. Rinse dirt from exterior of hypochlorination unit, model 1955-1.
- c. Refer to paragraph 4.13.2 and remove outlet, inlet, pressure regulating, fill, and drain hose assemblies.

NOTE

Tilt hypochlorination unit, model 1955-1 to aid in drainage.

- d. Allow hypochlorination unit, model 1955-1 and hose assemblies removed in step c to drain for several hours.

WARNING

To prevent eye injury, wear safety glasses when using compressed air.

- e. Using compressed air, thoroughly dry model 1955-1 hypochlorination unit and hose assemblies removed in step c.

4.19.6 Hypochlorination Unit, Model 1955-3 Preservation. Refer to applicable technical manual for preservation procedures for the model 1955-3 hypochlorination unit.

4.19.7 Hypochlorination Unit, Model A-506131 Preservation. Refer to applicable technical manual for preservation procedures for the model A-506131 hypochlorination unit.

4.20 PACKING.

Packing procedures for the TWDS are contained in paragraphs 4.22.1 through 4.22.6.

4.20.1 TWDS Components Packing. Refer to paragraph 2.8 for packing procedures. Perform the packing procedures detailed in paragraph 2.8 subparagraphs. The packing procedures for the hypochlorination unit, model 1955-1 are contained in paragraph 2.8.

4.20.2 600 GPM Pumping Assemblies Packing. Refer to applicable technical manual for packing procedures for the 600 GPM pumping assemblies.

4.20.3 20,000 Gallon Pillow Tank Packing. Refer to applicable technical manual for packing procedures for the 20,000 gallon pillow tank.

4.20.4 125 GPM Pumping Assembly Packing. Refer to applicable technical manual for packing procedures for the 125 GPM pumping assembly.

4.20.5 Hypochlorination Unit, Model 1955-3 Packing. Refer to applicable technical manual for packing procedures for the model 1955-3 hypochlorination unit.

4.20.6 Hypochlorination Unit, Model A-506131 Packing. Refer to applicable technical manual for packing procedures for the model A-506131 hypochlorination unit.

4.21 MARKING.

Refer to MIL-STD-129 for information on marking.

4.22 STORAGE.

- a. Store equipment so as to provide maximum protection from the elements and to provide access for inspection, maintenance, and servicing.
- b. Take into account environmental conditions, such as extreme cold or heat, high humidity, blowing snow, or combinations thereof, and take adequate precautions.

4.23 ADMINISTRATIVE STORAGE.

- a. Placement of equipment in administrative storage should be for short periods of time when a shortage of maintenance efforts exists. Items should be in mission readiness within 24 hours or within the time factors as determined by the directing authority. During the storage period appropriate maintenance records will be kept.
- b. Before placing equipment in administrative storage, current maintenance services and Preventive Maintenance Checks and Services (PMCS) should be completed, shortcomings and deficiencies should be corrected, and all modification work orders (MWO's) should be applied.
- c. Storage site selection. Inside storage is preferred for items selected for administrative storage. If inside storage is not available, trucks, vans, conex containers, and other containers may be used.

CHAPTER 5

DIRECT SUPPORT MAINTENANCE INSTRUCTIONS

Subject Index	Page
SECTION I.	
REPAIR PARTS; SPECIAL TOOLS; TEST, MEASUREMENT, AND DIAGNOSTIC EQUIPMENT (TMDE); AND SUPPORT EQUIPMENT	5-2
5.1	
Common Tools and Equipment.....	5-2
5.2	
Special Tools and Support Equipment.....	5-2
5.3	
Repair Parts.....	5-2
SECTION II.	
DIRECT SUPPORT MAINTENANCE PROCEDURES	5-3
5.4	
10-Mile Segment Equipment.....	5-3
5.5	
Pressure-Reducing Valve Assembly Maintenance.....	5-4
5.6	
Hypochlorination Unit, Model 1955-1, Maintenance.....	5-11

**SECTION I. REPAIR PARTS; SPECIAL TOOLS; TEST, MEASUREMENT, AND DIAGNOSTIC EQUIPMENT
(TMDE); AND SUPPORT EQUIPMENT**

5.1 COMMON TOOLS AND EQUIPMENT.

For Authorized common tools and equipment refer to the Modified Table of Organization and Equipment (MTOE) applicable to your unit.

5.2 SPECIAL TOOLS AND SUPPORT EQUIPMENT.

No special tools and test equipment are required for the TWDS.

5.3 REPAIR PARTS.

Repair parts are listed and illustrated in the repair parts and special tools list (TM 10-4320-303-24P) covering unit, direct support, and general support maintenance for this equipment.

SECTION II. DIRECT SUPPORT MAINTENANCE PROCEDURES

5.4 10 MILE SEGMENT EQUIPMENT.

5.4.1 Flaking Box Assembly Repair.

This task covers:
 5.4.1.1 Repair

INITIAL SETUP

Equipment Conditions

Hoseline Segment removed from flaking box assembly.

General Safety Instructions

Do not work on equipment that is not securely stabilized to prevent sliding.
 Do not work on equipment without following standard shop safety precautions.

5.4.1.1 Repair.

WARNING

Do not work on equipment that is not securely stabilized to prevent sliding. Failure to do so may result in personal injury.

NOTE

Newer model flaking boxes can hold two 500 foot hose assemblies. Older model flaking boxes can hold only one 500 foot hose assembly.

- a. Repair of the flaking box assembly consists of welding cracked seams and frame members in accordance with MIL-STD-1261 and TM 9-237.

5.5 PRESSURE-REDUCING VALVE ASSEMBLY MAINTENANCE.

5.5.1 Pressure-Reducing Control Repair.

This task covers:

5.5.1.1 Disassembly

5.5.1.2 Inspection

5.5.1.3 Assembly

INITIAL SETUP

Tools

Tool Kit, General Mechanic's,
Automotive, Section III, Item 1,
Appendix B

Torque Wrench, Section III, Item 2,
Appendix B

Equipment Conditions

Pressure-Reducing Control removed, paragraph
4.11.5.

General Safety Instructions

Do not work on equipment without following
standard shop safety precautions.

Materials/Parts

Gasket (TM 10-4320-303-23P)

5.5.1.1 Disassembly.

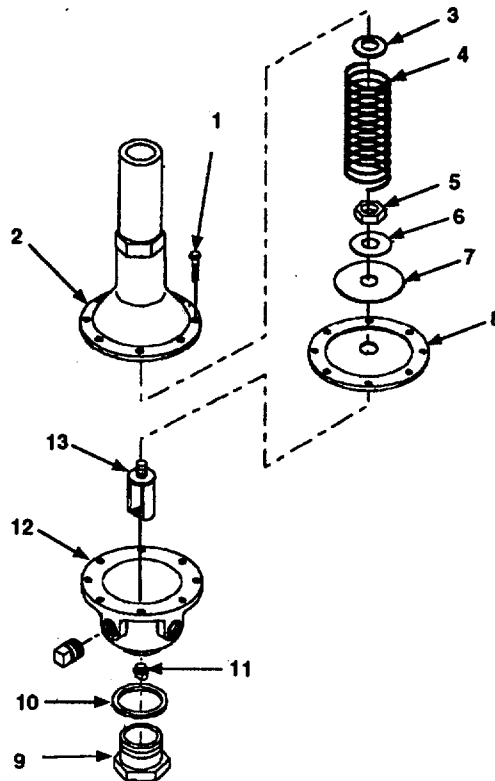


Figure 5-1. Pressure-Reducing Control Maintenance

NOTE

Adjusting screw has been factory calibrated and should not be adjusted.

- a. Remove eight cover screws (Figure 5-1, 1).
- b. Remove cover (2).
- c. Remove spring guide (3) and spring (4).
- d. Remove nut (5).
- e. Remove belleville washer (6), diaphragm washer (7), and diaphragm (8).
- f. Remove plug (9).
- g. Remove gasket (10) from plug (9). Discard gasket (10).
- h. Unscrew disc retainer assembly (11), CCW.
- i. Remove disc retainer assembly (11) through hole in bottom of body (12).
- j. Remove yoke (13) from body (12).

5.5.1.2 Inspection.

- a. Inspect all metal parts for cracks, holes, corrosion, or signs of wear and damage.
- b. Inspect spring (4) for bends, corrosion, or damage.
- c. Inspect diaphragm (8) for holes, slices, tears, or damage.
- d. Inspect all mounting hardware for damage.
- e. Replace damaged screws (1), spring (4), diaphragm (8), disc retainer assembly (11).
- f. If any other pressure-reducing control components are damaged, replace pressure-reducing control.

5.5.1.3 Assembly.

- a. Install yoke (13) in body (12).
- b. Insert disc retainer assembly (11) through hole in body (12) and thread disc retainer assembly (11) into yoke (13) until it bottoms.

NOTE

Disc retainer assembly must enter guide hole in plug as it is being assembled.

- c. Install new gasket (10) on plug (9). Install plug (12).
- d. Install diaphragm (8), diaphragm washer (7), belleville washer (6) on yoke (13).
- e. Install nut (5). Do not tighten nut (5).
- f. Adjust diaphragm (8) so that holes in diaphragm (8) align with holes in body (12).
- g. Torque nut (5) to 45 to 55 lb in.

5.5.1 Pressure-Reducing Control Repair. (Continued)

- h. Check alignment of diaphragm (8). Move diaphragm left and right as far as possible. Holes in diaphragm (8) should move equal distance to either side of holes in body (12) within 1/8 in. If diaphragm does not align, repeat steps d through g above.
- i. Move yoke (13) to OPEN and CLOSE positions. Make sure yoke (13) moves back and forth smoothly and does not make contact with nozzle on body (12).
- j. Install spring guide (3) on top of spring (4). Install spring (4) and spring guide (3).
- k. Install cover (2) on body (12). Align holes in cover (2) with holes in body (12).
- l. Install eight screws (1). Tighten screws (1).

5.5.2 Main Valve Assembly Repair.

This task covers:

5.5.2.1 Disassembly

5.5.2.3 Assembly

5.5.2.2 Repair

INITIAL SETUP

Tools

Tool Kit, General Mechanic's,
Automotive, Section III, Item 1,
Appendix B

Material/Parts

Sandpaper, Section II, Item 138,
Appendix C.

Equipment Conditions

Main Valve Assembly removed, paragraph
4.11.5.

General Safety Instructions

Do not work on equipment without following
standard shop safety precautions.

5.5.2.1 Disassembly.

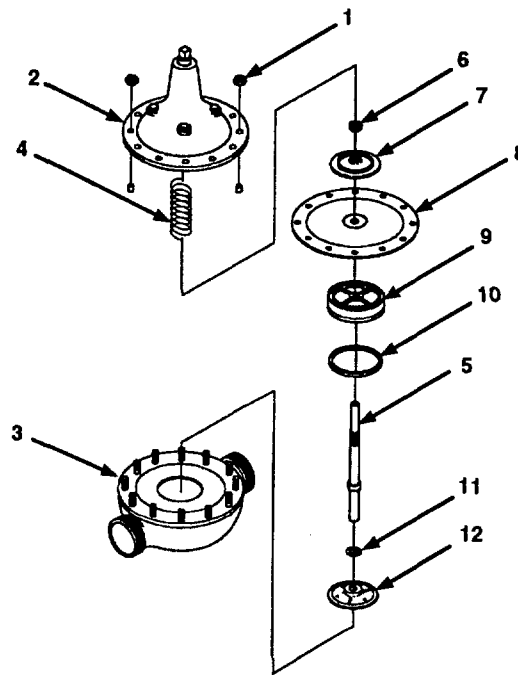


Figure 5-2. Main Valve Assembly Maintenance.

- a. Remove twelve hex nuts (Figure 5-2, 1).

5.5.2 Main Valve Assembly Repair. (Continued)**WARNING**

Remove cover slowly to release spring tension. Failure to do so may result in personal injury and injury to personnel.

CAUTION

Pull cover straight up when removing cover from main valve. Failure to do so may result in damage to cover bearing or valve stem.

- b. Slowly lift cover (2) from valve body (3).
- c. Remove spring (4) from valve stem (5).

CAUTION

Use vise with soft brass jaws. Failure to do so may result in damage to valve stem.

- d. Secure lower end of valve stem (5) in vice with soft jaws.
- e. Examine threads on valve stem (5) above stem nut (6) for signs of corrosion or mineral deposits. If needed, clean threads on valve stem (5) with wire brush before removing stem nut (6).
- f. Remove stem nut (6).
- g. Remove diaphragm washer (7), diaphragm (8), disc ring retainer (9), and disc ring (10) from valve stem (5).
- h. Pry disc ring (10) from disc ring retainer (9). Remove disc (11) from disc ring retainer (9).
- i. Remove disc guide (12) from valve body (3).

5.5.2.2 Repair.

- a. Inspect valve stem (5) for corrosion and scale. If required, use sandpaper moistened with water to clean valve stem (5).

NOTE

If new disc ring is unavailable, flip old disc ring over.

- b. Inspect diaphragm (8) and disc (11) for signs of wear, corrosion, and damage.
- c. Inspect remaining parts for signs of cracks, holes, wear, corrosion, and damage.
- d. Replace all defective components.

5.5.2.3 Assembly.

- a. Install disc guide (12) in valve body (3).
- b. Install disc ring (10) in disc ring retainer (9).
- c. Install disc ring retainer (9), diaphragm (8), and diaphragm washer (7) on valve stem (5).

NOTE

If new disc is installed, a different number of spacers may be required to obtain right amount of grip on disc.

- d. Install valve stem (5) in disc guide (12).

CAUTION

- When installing stem nut, tighten nut until diaphragm cannot be twisted. If nut is loose, diaphragm could pull loose and tear under pressure.
- When tightened, make sure disc is not compressed too much. Disc should be compressed only very slightly by disc guide. If needed, remove or insert enough spacers to obtain proper disc compression.

- e. Install stem nut (6). Tighten stem nut (6).

- f. Align holes in diaphragm (8) with studs in valve body (3). Stretch diaphragm (8) over studs in valve body (3).

- g. Install spring (4) over valve stem (5).

CAUTION

When installing cover, make sure diaphragm is lying smooth under cover. If diaphragm is not smooth, valve will not work properly.

- h. Align holes in cover (2) with studs in valve body (3). Carefully install cover (2) over studs on valve body (3).

- i. Install twelve hex nuts (1) on studs of valve body (4).

5.5.3 Pressure-Reducing Valve Assembly Skid Assembly Repair.

This task covers:

5.5.3.1 Repair

INITIAL SETUPEquipment Conditions

Skid Assembly removed, paragraph 4.11.5.

General Safety Instructions

Do not work on equipment that is not securely stabilized to prevent sliding.

Do not work on equipment without following standard shop safety precautions.

5.5.3.1 Repair.**WARNING**

Do not work on equipment that is not securely stabilized to prevent sliding. Failure to do so may result in personal injury.

- a. Repair of pressure-reducing valve assembly skid consists of welding cracked seams and frame members in accordance with MIL-STD-1261 and TM 9-237.

5.6 HYPOCHLORINATION UNIT. MODEL 1955-1, MAINTENANCE.

5.6.1 Pilot Valve Assembly Maintenance.

This task covers:

- | | |
|--------------------|------------------|
| 5.6.1.1 Removal | 5.6.1.3 Repair |
| 5.6.1.2 Inspection | 5.6.1.4 Assembly |

INITIAL SETUP

Tools

Tool Kit, General Mechanic's,
Automotive, Section III, Item 1,
Appendix B

Goggles, Section III, Item 2,
Appendix B

Materials/Parts

Cleaning Solvent, Item 8, Appendix E
Gloves, Item 4, Appendix E
Apron, Item 1, Appendix E

Equipment Conditions

125 GPM pumping assembly shutdown, refer to applicable technical manual.

Strainer Assembly removed, paragraph 4.13.4.

Water Meter and Gear Box Assembly removed, paragraph 4.13.5.

General Safety Instructions

Do not work on equipment without following standard shop safety precautions.

5.6.1.1 Removal.

- a. Remove two screws (Figure 5-3, 1).
- b. Remove end cap (2) and lock spring cap (3).
- c. Remove thumbscrew (4).
- d. Remove yoke cover (5) from gear box (6).
- e. Loosen rod lock nut (7).
- f. Remove valve rod (8) from link spring coupling (9).
- g. Remove four screws (10).
- h. Remove valve housing (11) and gasket (12) from gear box (6). Discard old gasket (12).
- i. Remove retainer ring (13).
- j. Remove rod lock nut (7) from valve rod (8).
- k. Slide entire valve rod (8) and slug assembly (14) out of valve housing (11).
- l. Remove valve sleeve (15) from valve housing (11).
- m. Remove four screws (16), valve housing cap (17) and pipe plug (18) from valve housing (11).

5.6.1 Pilot Valve Assembly Maintenance. (Continued)

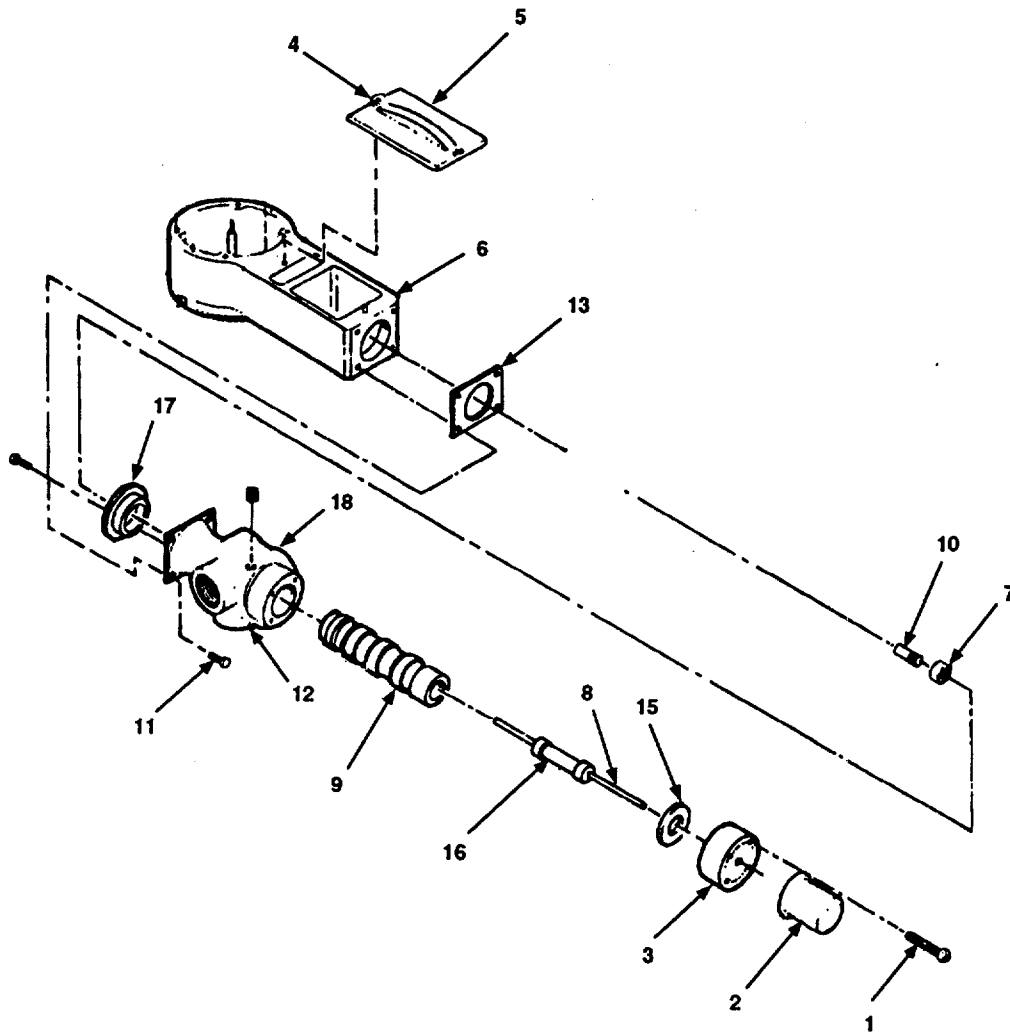


Figure 5-3. Pilot Valve Assembly Maintenance.

5.6.1.2 Inspection.

- a. Inspect end cap (2), lock spring cap (3), yoke cover (5), valve sleeve (9), valve housing (11), and valve housing cap (17) for cracks, holes, corrosion, or damage.
- b. Inspect all mounting hardware for corrosion and damage.

WARNING

- Dry cleaning solvent used to clean parts is potentially dangerous to personnel and property. Avoid repeated or prolonged skin contact. Do not use near open flame or excessive heat. Flash point of solvent is 100-138 degrees Fahrenheit (38-60 C).
 - To prevent injury to eyes, safety glasses must be worn when using compressed air.
 - Failure to obey these warnings may result in personal injury or death.
- c. Clean all reusable components with compressed air or cleaning solvent as appropriate.
- d. Dry all components cleaned using cleaning solvent with compressed air.

5.6.1.3 Repair. Repair consists of replacing all damaged or defective components.

5.6.1.4. Assembly.

- a. Install pipe plug (18), valve housing cap (17) and four screws (16) in valve housing (11). Tighten screws (16).
- b. Install valve sleeve (15) in valve housing (11).
- c. Install slug assembly (14) and valve rod (8) in valve housing (11).
- d. Install rod lock nut (7) on valve rod (8). Turn rod lock nut (7) two or three times for installation of valve rod (8) in spring link coupling (9).
- e. Install retainer ring (13), lock spring cap (3) with two screws (1) on valve housing (11).
- f. Place new gasket (12) and valve housing (11) on gear box (6).
- g. Insert four screws (10). Tighten screws (10).
- h. Attach valve rod (8) to link spring coupling (9).
- i. Tighten rod lock nut (7).
- j. Grasp end of valve rod (8). Slowly move valve rod (8) back and forth to test for smooth operation. If valve rod (8) sticks or movement is rough, foreign matter is in valve sleeve (15) area. Repeat steps 5.6.1.1 k through m and inspect parts for cleanliness. Refer to paragraph 5.6.1.2 and clean all items as appropriate. Repeat steps 5.6.1.4 a through j until valve rod movement is smooth.

CAUTION

Do not over tighten thumbscrew or it may break.

- k. Install yoke cover (5) on gear box (6).
- l. Install thumbscrew (4). Tighten thumbscrew (4).
- m. Install end cap (2) on lock spring cap (3).
- n. Insert two screws (1). Tighten screws (1).

5.6.2 Gear Box Maintenance.

This task covers:

- | | |
|---------------------|------------------|
| 5.6.2.1 Disassembly | 5.6.2.3 Repair |
| 5.6.2.2 Inspection | 5.6.2.4 Assembly |
-

INITIAL SETUP

Tools

Tool Kit, General Mechanic's,
Automotive, Section III, Item 1,
Appendix B

Materials/Parts

Gasket (TM 10-4320-303-23P)
Cotter Pin (TM 10-4320-303-23P)

Equipment Conditions

125 GPM pumping assembly shutdown, refer to applicable technical manual.

Water Meter and Gear Box Assembly removed, paragraph 4.13.5.

Pilot Valve Assembly removed, paragraph 5.6.1.

General Safety Instructions

Do not work on equipment without following standard shop safety precautions.

5.6.2.1 Disassembly.

- a. Remove two cap screws (Figure 5-4, 1).
- b. Remove valve cap (2) from gear box cover (3).
- c. Remove register mechanism subassembly (4) and gasket (5).
- d. Loosen socket-head screw (6) and remove register gear (7) from main drive shaft (8).
- e. Remove four screws (9).
- f. Gently pry around edge of gear box cover (3) and remove gear box cover (3) from gear box (10).
- g. Remove gasket (11). Discard gasket (11).
- h. Remove crank arm pin (12). Turn crank arm assembly (13) away from spring lock sleeve (14).
- i. Remove crank arm assembly (13) from crank (15).
- j. Remove crank (15) and gear assembly (16).
- k. Remove cotter pin (17). Discard cotter pin (17).
- l. Remove drive bushing and gear assembly (18) from main drive shaft (8).
- m. Remove spring link coupling (19) from spring link cap (20).
- n. Remove spring link cap (20), lock washer (21), spring collar screw (22), spring (23), and flat washer (24).
- o. Remove spring screw (25) from spring link lock nut (26).
- p. Remove spring link lock nut (26) from spring lock sleeve (14).
- q. Loosen four socket-head screws (27).

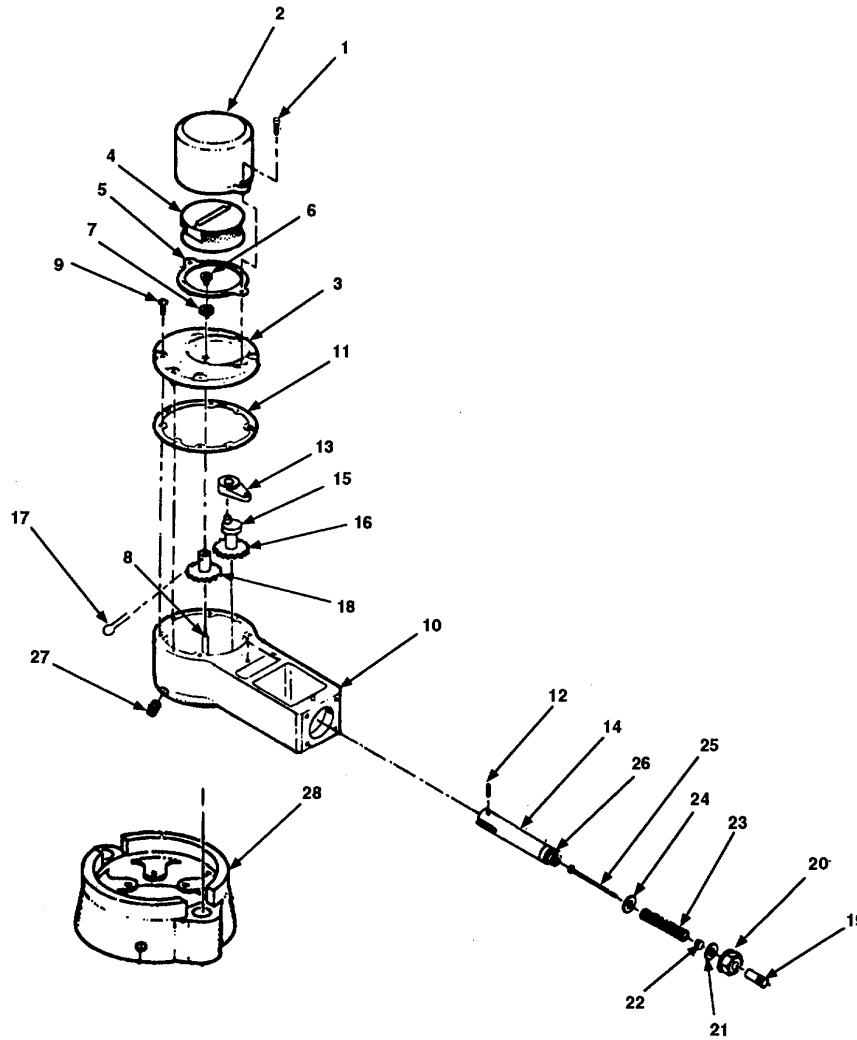


Figure 5-4. Gear Box Maintenance.

r. Remove gear box (10) from meter mounting cup (28).

5.6.2.2 Inspection.

- a. Inspect all components for cracks, holes, corrosion, or damage.
- b. Inspect all mounting hardware and other items for corrosion or damage.

5.6.2.3 Repair. Repair consists of replacing all damaged or defective components.

5.6.2 Gear Box Maintenance. (Continued)**5.6.2.4 Assembly.**

- a. Install gear box (10) on meter mounting cup (28).
- b. Insert four socket-head screws (27). Tighten screws (27).
- c. Install spring lock nut (26) on spring lock sleeve (27).
- d. Install spring screw (25) on spring lock nut (26).
- e. Install flat washer (24), spring (23), spring collar screw (22), lock washer(21), and spring cap link (20) on spring screw (25).
- f. Install spring link coupling (19) in spring link cap (20).
- h. Install drive bushing and gear assembly (18) on main drive shaft (8).
- i. Install new cotter pin (17) in main drive shaft (8).
- j. Install gear assembly (16) and crank (15).
- k. Install crank arm assembly (13) on crank (15).
- l. Align crank arm (13) in spring lock sleeve (14) and install crank arm pin(12).
- m. Install new gasket (11) and gear box cover (3) on gear box (10).
- n. Install four mounting screws (9). Tighten screws (9).
- o. Install register gear (7) on main drive shaft (8).
- p. Tighten socket-head screw (6).
- q. Install new gasket (5) and register mechanism subassembly (4) on gear boxcover (3).
- r. Install valve cap (2) on gear box cover (3).
- s. Install two screws (1). Tighten screws (1).

5.6.3 Water Meter Maintenance.

This task covers:

- | | |
|---------------------|------------------|
| 5.6.3.1 Disassembly | 5.6.3.3 Repair |
| 5.6.3.2 Inspection | 5.6.3.4 Assembly |
-

INITIAL SETUP

Tools

Tool Kit, General Mechanic's,
Automotive, Section III, Item 1,
Appendix B

Materials/Parts

Gasket (TM 10-4320-303-23P)

Equipment Conditions

125 GPM pumping assembly shutdown,
refer to applicable technical manual.

Equipment Conditions (Continued)

Gear Box removed, refer to paragraph 5.6.2.

General Safety Instructions

Do not work on equipment without following
standard shop safety precautions.

5.6.3.1 Disassembly.

- a. Remove two screws (Figure 5-5, 1).
- b. Remove meter mounting cup (2) from top casing (3).
- c. Remove six nuts (4) and bolts (5).
- d. Remove top casing (3) and gasket (6) from bottom casing (7). Discard gasket (6).
- e. Remove top gear (8), first intermediate gear (9), and intermediate pinion (10) from gear plate (11).
- f. Remove two gear plate screws (12) and gear plate (11).
- g. Remove rubber roller (13) from drive shaft (14).
- h. Remove drive shaft (14) from disc chamber top (15).
- i. Remove top disc chamber (15) from rubber disc (16).
- j. Remove diaphragm (17) from rubber disc (16).
- k. Remove rubber disc (16) and bottom disc chamber (18) from bottom casing (7).

5.6.3.2 Inspection.

- a. Inspect meter mounting cup (2), top casing (3), bottom casing (7), top disc chamber (15), and bottom disc chamber (18) for corrosion, cracks, holes, or damage.
- b. Inspect rubber roller (11), rubber disc (16), and diaphragm (17) for corrosion, cracks, tears, slices, or damage.
- c. Inspect all other components for corrosion, cracks, or damage.

5.6.3.3 Repair. Repair consists of replacing all damaged or defective components.

5.6.3 Water Meter Maintenance. (Continued)

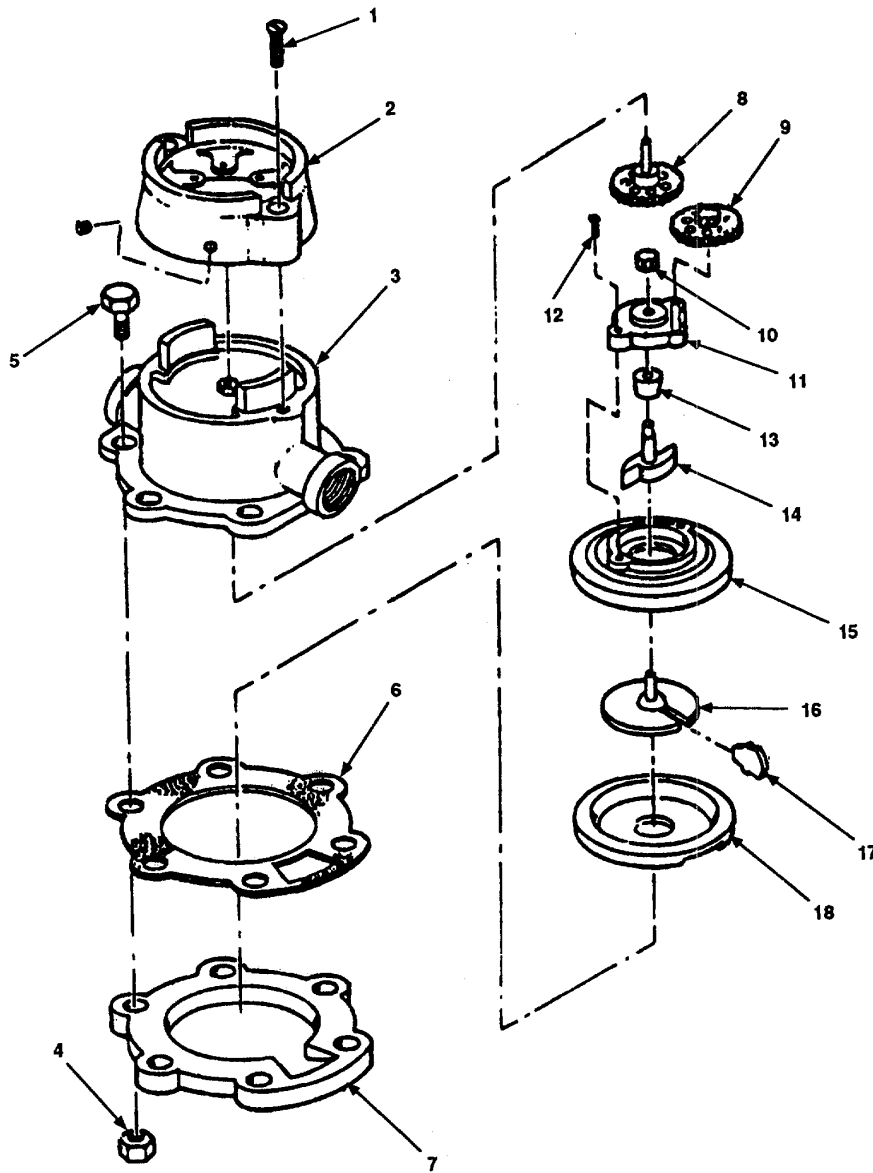


Figure 5-5. Water Meter Maintenance.

5.6.3.4 Installation.

- a. Install bottom disc chamber (18) and rubber disc (16) in bottom casing (7).

- b. Install diaphragm (17) in rubber disc (16).
- c. Install top disc chamber (15) on rubber disc (16).
- d. Install drive shaft (14) in top disc chamber (15).
- e. Install rubber roller (13) on drive shaft (14).
- f. Install gear plate (11) on drive shaft (14) and insert two screws (12). Tighten screws (12).
- g. Install intermediate pinion (10), first intermediate gear (9), and top gear (8) on gear plate (11).
- h. Place new gasket (6) and top casing (3) on bottom casing (7).
- i. Install six bolts (5) and nuts (4). Tighten nuts (4).
- j. Install meter mounting cup (2) on top casing (3).
- k. Install two screws (1). Tighten screws (1).

5.6.4 Pressure Regulating Valve Repair.

This task covers:

5.6.4.1 Disassembly

5.6.4.3 Assembly

5.6.4.2 Inspection

INITIAL SETUP

Tools

Tool Kit, General Mechanic's,
Automotive, Section III, Item 1,
Appendix B

Materials/Parts

Gasket (TM 10-4320-303-23P)

Equipment Conditions

125 GPM pumping assembly shutdown, refer to applicable technical manual.

Pressure Regulating Valve removed, paragraph 4.13.7.

General Safety Instructions

Do not work on equipment without following standard shop safety precautions.

5.6.4.1 Disassembly.

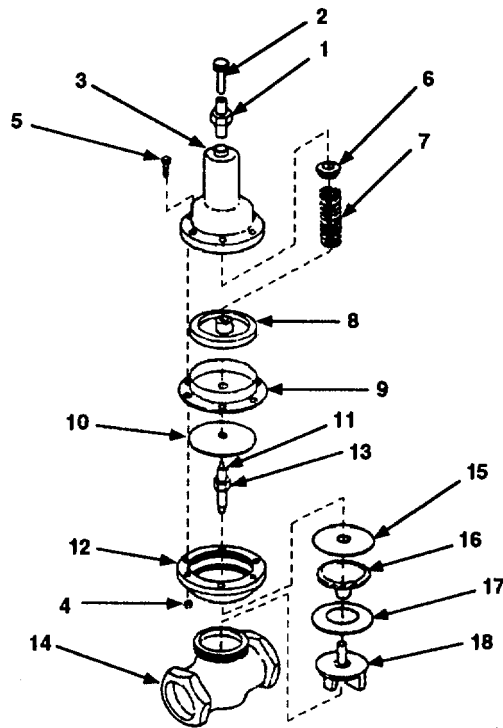


Figure 5-6. Pressure Regulating Valve Maintenance.

- a. Loosen jam nut (Figure 5-6, 1).
- b. Remove setscrew (2) and jam nut (1) from pressure valve cap (3).
- c. Remove six nuts (4) and bolts (5).

WARNING

Pressure regulating valve spring is under pressure. Slowly remove pressure valve cap to prevent flying components. Failure to obey this warning may result in personal injury or injury to personnel.

- d. Slowly remove pressure valve cap (3), seat (6), and spring (7).
- e. Remove valve piston (8), valve diaphragm (9), valve retainer disk (10), and connecting link (11) from pressure valve retainer (12).
- f. Remove nut (13) from connecting link (11).
- g. Separate valve piston (8), valve diaphragm (9), valve retainer disk (10), and connecting link (11).
- h. Remove pressure valve retainer (12) from body (14).
- i. Remove flat washer (15), disc guide (16), gasket (17), and valve disk (18) from body (14). Discard old gasket (17).

5.6.4.2 Inspection.

- a. Inspect pressure valve cap (3), pressure valve retainer (12), and body (14) for corrosion, cracks, holes, or damage.
- b. Inspect all other components for corrosion or damage.
- c. Replace all defective components.

5.6.4.3 Assembly.

- a. Install valve disc (18), new gasket (17), disc guide (16), and flat washer (15) in body (14).
- b. Place pressure valve retainer (12) on body (14).
- c. Assemble valve retainer disc (10), valve diaphragm (9), and valve piston (8) on connecting link (11).
- d. Install nut (13) on connecting link (11).
- e. Insert connecting link (11), valve retainer disk (10), valve diaphragm (9), and valve piston (8) in pressure valve retainer (12).
- f. Install spring (7), seat (6), and pressure valve cap (3).
- g. Align holes in pressure valve cap (3) with holes in pressure valve retainer (12).
- h. Secure pressure valve cap (3) and pressure valve retainer (12).
- i. Install six bolts (5) and nuts (4). Tighten nuts (4).
- j. Install setscrew (2) in pressure valve cap (3).
- k. Install jam nut (1).

5.6.5 Hypochlorination Unit Frame Assembly Repair.

This task covers:
5.6.5.1 Repair

INITIAL SETUP**Equipment Conditions**

Hypochlorination Unit Frame Assembly removed, paragraph 4.13.8.

General Safety Instructions

Do not work on equipment that is not securely stabilized to prevent sliding.

Do not work on equipment without following standard shop safety precautions.

5.6.5.1 Repair.**WARNING**

Do not work on equipment that is not securely stabilized to prevent sliding. Failure to do so may result in personal injury.

- a. Repair of hypochlorination unit frame assembly consists of welding cracked seams and frame members in accordance with MIL-STD-1261 and TM 9-237.

APPENDIX A

REFERENCES

A.1 SCOPE.

This appendix lists all forms, field manuals, technical manuals, and miscellaneous publications referenced in this manual.

A.2 FORMS.

Recommended Changes to Publications and Blank Forms	DA Form 2028
Recommended Changes to Equipment Technical Publications.....	DA Form 2028-2
Depreservation Guide for Vehicles and Equipment.....	DA Form 2258
Equipment Inspection and Maintenance Worksheet.....	DA Form 2404
Report of Discrepancy (ROD).....	SF 364
Product Quality Deficiency Report.....	SF 368

A.3 FIELD MANUALS.

NBC Contamination Avoidance	FM 3-3
NBC Protection	FM 3-4
Fixed Site Protection	FM 3-4-1
NBC Decontamination.....	FM 3-5
Field Behavior of NBC Agents.....	FM 3-6
Chemical Reference Handbook.....	FM 3-8
First Aid for Soldiers	FM 21-11

A.4 TECHNICAL MANUAL .

Operator's Manual for Welding, Theory and Applications.....	TM 9-237
Procedures for Destruction of Equipment to Prevent Enemy Use (Mobility Equipment Command)	TM 750-244-3
Operator's and Unit Maintenance Manual for 20,000 Gallon Collapsible Fabric Tank.....	TM 5-5430-226-12
Operator's Unit, Intermediate Direct Support and Intermediate General Support Maintenance (Including Repair Parts and Special Tools List) Compressor, Rotary, Air, DED, 250 CFM, 100 PSI, Trailer Mounted	TM 5-4310-452-14&P
Organizational, Direct Support, and General Support Repair Parts and Special Tools List for Tactical Water Distribution Equipment System (TWDS) Set 10-Mile Segment, Models 06749-0183-81, 110-00-0000, 919 and 10.....	TM 10-4320-303-23P

A.5 MISCELLANEOUS PUBLICATIONS .

Abbreviations for Use on Drawings, and in Specifications, Standards and Technical Documents	MIL-STD-12
Marking for Shipment and Storage	MIL-STD-129
Arc Welding Procedures for Structural Steels	MIL-STD-1261
Dictionary of United States Army Terms.....	AR 310-25
Army Logistics and Readiness.....	AR 700-138
Functional User's Manual for the Army Maintenance Management System (TAMMS)	DA Pam 738-750
Functional User's Manual for the Army Maintenance Management System-Aviation (TAMMS-A)	DA Pam 738-751
Occupational and Environmental Health.....	TB-MED-577

**APPENDIX B
MAINTENANCE ALLOCATION CHART (MAC)**

**SECTION I.
INTRODUCTION**

B.1 THE ARMY MAINTENANCE SYSTEM MAC.

B.1.1 Introduction. This introduction (Section I) provides a general explanation of all levels of maintenance and repair functions authorized at various maintenance levels under the standard Army Maintenance System concept.

B.1.2 Maintenance Allocation Chart Section II. The Maintenance Allocation Chart (MAC) in section II designates overall authority and responsibility for the performance of maintenance functions on the identified end item or component. The application of the maintenance functions to the end item or component will be consistent with the capacities and capabilities of the designated maintenance levels, which are shown on the MAC in column (4) as:

Unit - includes two subcolumns, C (operator/crew) and O (unit) maintenance

Direct support - includes an F subcolumn

General support - includes an H subcolumn

Depot - includes a D subcolumn

B.1.3 Tools and Test Equipment Introduction. Section III lists the tools and test equipment (both special tools and common tool sets) required for each maintenance function as referenced from section II.

B.1.4 Supplemental Instructions Introduction. Section IV contains supplemental instructions and explanatory notes for a particular maintenance function.

B.2 MAINTENANCE FUNCTIONS.

Maintenance functions are limited to and defined as follows:

B.2.1 Inspect. To determine the serviceability of an item by comparing its physical, mechanical, and/or electrical characteristics with established standards through examination (e.g., by sight, sound, or feel).

B.2.2 Test. To verify serviceability by measuring the mechanical, pneumatic, hydraulic, or electrical characteristics of an item and comparing those characteristics with prescribed standards.

B.2.3 Service. Operations required periodically to keep an item in proper operating condition, i.e., to clean (includes decontaminate, when required), to preserve, to drain, to paint, or to replenish fuel, lubricants, chemical fluids, or gases.

B.2.4 Adjust. To maintain or regulate, within prescribed limits, by bringing into proper or exact position, or by setting the operating characteristics to specified parameters.

B.2.5 Align. To adjust specified variable elements of an item to bring about optimum or desired performance.

B.2.6 Calibrate. To determine and cause corrections to be made or to be adjusted on instruments or test, measuring, and diagnostic equipment used in precision measurement. Consists of comparisons of two instruments, one of which is a certified standard of known accuracy, to detect and adjust any discrepancy in the accuracy of the instrument being compared.

B.2.7 Remove/Install. To remove and install the same item when required to perform service or other maintenance functions. Install may be the act of emplacing, seating, or fixing into position a spare, repair part, or module (component or assembly) in a manner to allow the proper functioning of an equipment or system.

B.2.8 Replace. To remove an unserviceable item and install a serviceable counterpart in its place. "Replace" is authorized by the MAC and assigned maintenance level is shown as the 3d position code of the SMR code.

B.2.9 Repair. The application of maintenance services¹, including fault location/troubleshooting², removal/installation, and disassembly/assembly³ procedures, and maintenance actions⁴ to identify troubles and restore serviceability to an item by correcting specific damage, fault, malfunction, or failure in a part, subassembly, module (component or assembly), end item, or system.

B.2.10 Overhaul. That maintenance effort (service/action) prescribed to restore an item to a completely serviceable/operational condition as required by maintenance standards in appropriate technical publication (i.e., DMWR). Overhaul is normally the highest degree of maintenance performed by the Army. Overhaul does not normally return an item to like new condition.

B.2.11 Rebuild. Consists of those services/actions necessary for the restoration of unserviceable equipment to a like new condition in accordance with original manufacturing standards. Rebuild is the highest degree of materiel maintenance applied to Army equipment. The rebuild operation includes the act of returning to zero those age measurement (e.g., hour/miles) considered in classifying Army equipment/components.

B.3 EXPLANATION OF COLUMNS IN THE MAC, SECTION II.

B.3.1 Column 1, Group Number. Column 1 lists functional group code numbers, the purpose of which is to identify maintenance significant components, assemblies, subassemblies, and modules with the next higher assembly.

B.3.2 Column 2, Component/Assembly. Column 2 contains the item names of components, assemblies, subassemblies, and modules for which maintenance is authorized.

B.3.3 Column 3, Maintenance Function. Column 3 lists the functions to be performed on the item listed in Column 2. (For detailed explanation of these functions, see paragraph B.2.)

B.3.4 Column 4, Maintenance Level. Column 4 specifies each level of maintenance authorized to perform each function listed in Column 3, by indicating work-time required (expressed as manhours in whole hours or decimals) in the appropriate subcolumn. This work-time figure represents the active time required to perform that maintenance function at the indicated level of maintenance. If the number or complexity of the tasks within the listed maintenance function vary at different maintenance levels, appropriate work-time figures are to be shown for each level. The work-time figure represents the average time required to restore an item (assembly, subassembly, component, module, end item, or system) to a serviceable condition under typical field operating conditions. This time includes preparation time (including any necessary disassembly/assembly time), troubleshooting/fault

¹ Services - inspect, test, service, adjust, align, calibrate, and/or replace.

² Fault location/troubleshooting - The process of investigating and detecting the cause of equipment malfunctioning; the act of isolating a fault within a system or unit under test (UUT).

³ Disassembly/assembly - The step-by-step breakdown (taking apart) of a spare/functional group coded item to the level of its least component that is assigned an SMR code for the level of maintenance under consideration (i.e., identified as maintenance significant).

⁴ Actions - welding, grinding, riveting, straightening, facing, machining, and/or resurfacing.

location time, and quality assurance time in addition to the time required to perform the specific tasks identified for the maintenance functions authorized in the maintenance allocation chart. The symbol designations for the various maintenance levels are as follows:

- C..... Operator or crew maintenance
- O..... Unit maintenance
- F..... Direct Support maintenance
- L..... Specialized Repair Activity (SRA)⁵
- H..... General support maintenance
- D..... Depot maintenance

B.3.5 Column 5, Tools and Test Equipment Reference Code. Column 5 specifies, by code, those common tool sets (not individual tools), common TMDE, and special tools, special TMDE, and special support equipment required to perform the designated function. Codes are keyed to tools and test equipment in Section III.

B.3.6 Column 6, Remarks. When applicable, this column contains a letter code, in alphabetic order, which is keyed to the remarks contained in Section IV.

B.4 EXPLANATION OF COLUMNS IN TOOL AND TEST EQUIPMENT REQUIREMENTS, SECTION III .

B.4.1 Column 1, Reference Code. The tool and test equipment reference code correlates with a code used in the MAC, Section II, Column 5.

B.4.2 Column 2, Maintenance Level. The lowest level of maintenance authorized to use the tool or test equipment.

B.4.3 Column 3, Nomenclature. Name or identification of the tool or test equipment.

B.4.4 Column 4, National Stock Number. The National Stock Number of the tool or test equipment.

B.4.5 Column 5, Tool Number. The manufacturer's part number, model number, or type number.

B-5 EXPLANATION OF COLUMNS IN REMARKS, SECTION IV .

B.5.1 Column 1, Remarks Code. The code recorded in Column 6, Section II.

B.5.2 Column 2, Remarks. This column lists information pertinent to the maintenance function being performed as indicated in the MAC, Section II.

⁵This maintenance category is not included in Section II, column (4) of the Maintenance Allocation Chart. To identify functions to this category of maintenance, enter a work time figure in the "H" column of Section II, column (4), and use an associated reference code in the Remarks column (6). Key the code to Section IV, Remarks, and explain the SRA complete repair application there. The explanatory remark(s) shall reference the specific Repair Parts and Special Tools List (RPSTL) TM which contains additional SRA criteria and the authorized spare/repair parts.

**SECTION II. MAINTENANCE ALLOCATION CHART
FOR
TACTICAL WATER DISTRIBUTION EQUIPMENT SYSTEM (TWDS)
10-MILE SEGMENT**

(1) GROUP NUMBER	(2) COMPONENT/ ASSEMBLY	(3) MAINTENANCE FUNCTION	(4) MAINTENANCE LEVEL					(5) TOOLS AND EQUIPMENT REF CODES	(6) REMARKS CODES
			UNIT						
			C	O	F	H	D		
00	Tactical Water Distribution Equipment System, 10-Mile Segment								
01	TWDS Supply Connection Items								
0101	Y-Connection, Reducer	Inspect Replace Repair	0.1	0.1 0.3 0.5			1 1		
02	Pumping Station								
0201	Valve, Butterfly, 6 inch, Gear Actuated	Inspect Replace Repair	0.1	0.1 0.2 0.6			1 1		
0202	Hose Assembly, 6 inches x 10, 20, and 75 feet	Inspect Replace Repair	0.1 0.4	0.2			1		
0203	600 GPM Pumping Assembly							A B	
03	10-Mile Segment Equipment								
0301	Hose Assembly, Collapsible, 6 inches x 500 feet	Inspect Replace Repair	0.1 0.4	0.2			1	A	
030101	Flaking Box Assembly	Inspect Replace Repair	0.1	0.1 0.2 0.2	0.3		1, 2	C	
0302	Swivel Joint	Inspect Replace	0.1	0.1 0.2			1		
0303	Valve Assembly, Pressure- Reducing	Inspect Replace	0.1	0.1 0.2			1		
030301	Control, Pressure- Reducing	Inspect Replace Repair		0.1 0.3	0.6		1 1, 2		

**SECTION II. MAINTENANCE ALLOCATION CHART
FOR
TACTICAL WATER DISTRIBUTION EQUIPMENT SYSTEM (TWDS) SET
10-MILE SEGMENT (continued)**

(1) GROUP NUMBER	(2) COMPONENT/ ASSEMBLY	(3) MAINTENANCE FUNCTION	(4) MAINTENANCE LEVEL					(5) TOOLS AND EQUIPMENT REF CODES	(6) REMARKS CODES
			UNIT						
			C	O	F	H	D		
030302	Valve Assembly, Main	Inspect		0.1					
		Replace		0.3			1		
		Repair			0.5		1		
030303	Skid Assembly	Inspect		0.1					
		Replace		0.5			1		
		Repair			1.0			C	
0304	Valve Assembly, Pressure Relief	Inspect	0.1	0.1					
		Replace		0.5			1		
		Repair		0.5			1		
04	Storage Assembly								
0401	Valve, Gate, 4 inches, Flanged	Inspect	0.1	0.1					
		Replace		0.3			1		
		Repair		0.5			1		
0402	Tank, Pillow, 20,000 Gallons						D		
05	Distribution Point								
0501	Pumping Assembly, 125 GPM						E		
0502	Hypochlori- nation Unit, 1955-1	Inspect	0.1	0.1					
		Replace		0.5			1		
		Repair		1.0				F	
050201	Hose Assemblies, Outlet, Pressure, Inlet, Drain, and Fill	Inspect		0.1					
		Replace		0.3			1		
		Repair		0.5			1		
050202	Strainer Assembly	Inspect		0.3					
		Replace		0.5			1		
		Service		0.3			1		
050203	Pilot Valve Assembly	Inspect		0.1					
		Replace			1.0		1		
		Repair			1.0		1, 2		
050204	Water Meter and Gear Box Assembly	Inspect		0.2					
		Replace		0.5			1		

**SECTION II. MAINTENANCE ALLOCATION CHART
FOR
TACTICAL WATER DISTRIBUTION EQUIPMENT SYSTEM (TWDS) SET
10-MILE SEGMENT (continued)**

(1) GROUP NUMBER	(2) COMPONENT/ ASSEMBLY	(3) MAINTENANCE FUNCTION	(4) MAINTENANCE LEVEL					(5) TOOLS AND EQUIPMENT REF CODES	(6) REMARKS CODES
			UNIT		DS	GS	DEPOT		
			C	O	F	H	D		
05020401	Gear Box	Inspect		0.2					
		Replace			1.0			1	
		Repair			1.0			1	
05020402	Water Meter	Inspect		0.2					
		Replace			1.0			1	
		Repair			1.0			1	
050205	Hypochlorinator Assembly	Inspect		0.1					
		Replace		0.5				1	
		Repair		0.8				1	
050206	Manifold Assembly	Inspect		0.1					
		Replace		0.5				1	
		Repair		0.8				1	
05020601	Pressure Regulating Valve	Inspect		0.1					
		Replace		0.5				1	
		Repair			1.0			1	
050207	Frame Assembly	Inspect		0.1					
		Replace		0.3				1	
		Repair		0.2	0.2				C
0503	Stand Assembly	Inspect	0.1	0.1					
		Replace		0.5				1	
		Repair		0.8				1	
0504	Comparator, Color	Inspect	0.1						
		Replace		0.3					
		Repair		0.5				1	
06	Suspension Kit	Inspect	0.1	0.1					
		Replace		0.1					
		Repair		0.5					G
07	Displacement and Evacuation Kit	Inspect	0.1	0.2					
		Replace		0.3					
		Repair		0.5					G
0701	Ball Inlet	Inspect		0.1					
		Replace		0.1					
		Repair		0.2					
0702	Ball Outlet	Inspect		0.1					
		Replace		0.1					
		Repair		0.2					
08	Packing Kit	Inspect	0.1	0.1					
		Replace		0.3					
		Repair		0.6					G

**SECTION II. MAINTENANCE ALLOCATION CHART
FOR
TACTICAL WATER DISTRIBUTION EQUIPMENT SYSTEM (TWDS) SET
10-MILE SEGMENT (continued)**

(1) GROUP NUMBER	(2) COMPONENT/ ASSEMBLY	(3) MAINTENANCE FUNCTION	(4) MAINTENANCE LEVEL					(5) TOOLS AND EQUIPMENT REF CODES	(6) REMARKS CODES
			UNIT		DS	GS	DEPOT		
			C	O	F	H	D		
0801	Bracket, Hose Retaining	Inspect		0.1				1	G
		Replace		0.3					
09	Repair Kit	Repair		0.2					
		Inspect	0.1	0.2					
		Replace		0.3					
10	Repair Sling Assembly	Repair		0.5					
		Inspect	0.1	0.1				1	
		Replace		0.3				1	
		Repair		0.5					

**SECTION III. TOOL AND TEST EQUIPMENT REQUIREMENTS
FOR
TACTICAL WATER DISTRIBUTION EQUIPMENT SYSTEM (TWDS) SET
10-MILE SEGMENT**

(1) TOOL OR TEST EQUIPMENT REF CODE	(2) MAINTENANCE LEVEL	(3) NOMENCLATURE	(4) NATIONAL/NATO STOCK NUMBER	(5) TOOL NUMBER
1	0	Tool Kit, General Mechanic's, Automotive	5180-00-177-7033	
2	0	Shop Equipment, Automotive Maintenance and Repair: Organizational Maintenance, Common No. 1	4910-00-754-0654	

**SECTION IV. REMARKS
FOR
TACTICAL WATER DISTRIBUTION EQUIPMENT SYSTEM (TWDS)
10-MILE SEGMENT**

(1) REFERENCE CODE	(2) REMARKS
A	Repair Kit, Hoseline, 6 inches Item 124, of Appendix C is used for repair/replacement of hoses of the Tactical Water Distribution Equipment System (TWDS), 10-Mile Segment.
B	Refer to applicable technical manual for maintenance procedures for the 600 Gallons Per Minute Pump.
C	Direct Support Maintenance repair consists of welding damaged components.
D	Refer to applicable technical manual for maintenance procedures for the 20,000 Gallon Water Storage Tank.
E	Refer to applicable technical manual for maintenance procedures for the 125 Gallons Per Minute Pump.
F	Refer to applicable technical manual for maintenance procedures for the Hypochlorination Unit Model: 1955-3 and applicable technical manual for the Hypochlorination Unit Model: A-506131.
G	Repair of this kit is limited to the replacement of damaged, missing, or expended items.

APPENDIX C

COMPONENTS OF END ITEM AND BASIC ISSUE ITEMS LISTS

SECTION I. INTRODUCTION

C.1 SCOPE.

This appendix lists components of the end item and basic issue items for the pump to help you inventory the items for safe and efficient operation of the equipment.

C.2 GENERAL.

The Components of End Item (COEI) and Basic Issue Items (BII) Lists are divided into the following sections:

C.2.1 Section II, Components of End Item. This listing is for information purposes only, and is not authority to requisition replacements. These items are part of the TWDS. As part of the end item, these items must be with the end item whenever it is issued or transferred between property accounts. Items of COEI are removed and separately packaged for transportation or shipment only when necessary. Illustrations are furnished to help you find and identify the items.

C.2.2 Section III, Basic Issue Items. These essential items are required to place the TWDS in operation, operate it, and to do emergency repairs. Although shipped separately packaged, BII must be with TWDS during operation and when it is transferred between property accounts. This list is your authority to request/requisition them for replacement based on authorization of the end item by the TOE/MTOE. Illustrations are furnished to help you find and identify the items.

C.3 EXPLANATION OF COLUMNS.

C.3.1 Column (1). The first column, Illus Number, gives you the number of the item illustrated.

C.3.2 Column (2). The second column, National Stock Number, identifies the stock number of the item to be used for requisitioning purposes.

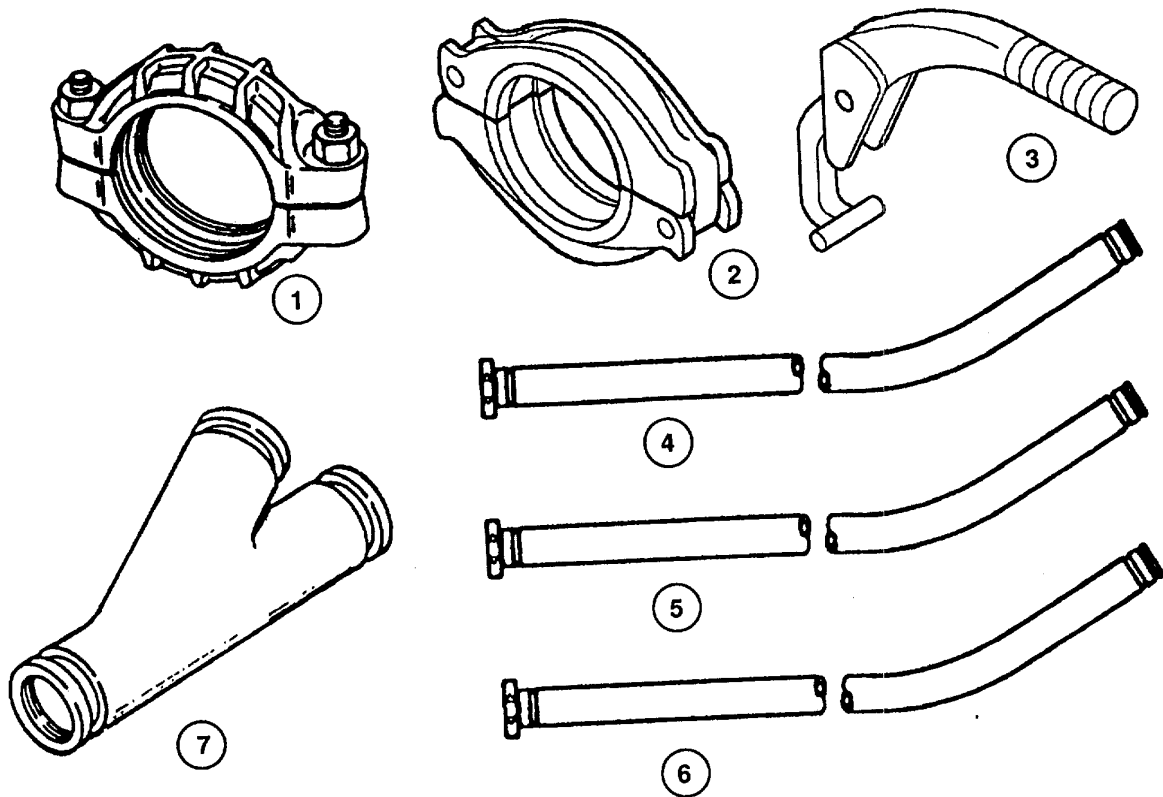
C.3.3 Column (3). The third column, Description and Usable On Code, identifies the Federal item name (in all capital letters) followed by a minimum description when needed. The last line below the description is the Commercial and Government Entity Code (CAGEC) (in parentheses) and the part number. If the item you need is not the same for different models of the equipment, a Usable On Code will appear on the right side of the description column on the same line as the part number. These codes are identified below:

<u>CODE</u>	<u>USED ON</u>
DTC	Model 06749-0183-81
DTQ	Model 110-00-0000
DTR	Model 919
EAM	Model 10

C.3.4 Column (4). The fourth column, U/I (unit of issue), indicates how the item is issued for the National Stock Number shown in column two.

C.3.5 Column (5). The fifth column, Qty Rqd, indicates the quantity required.

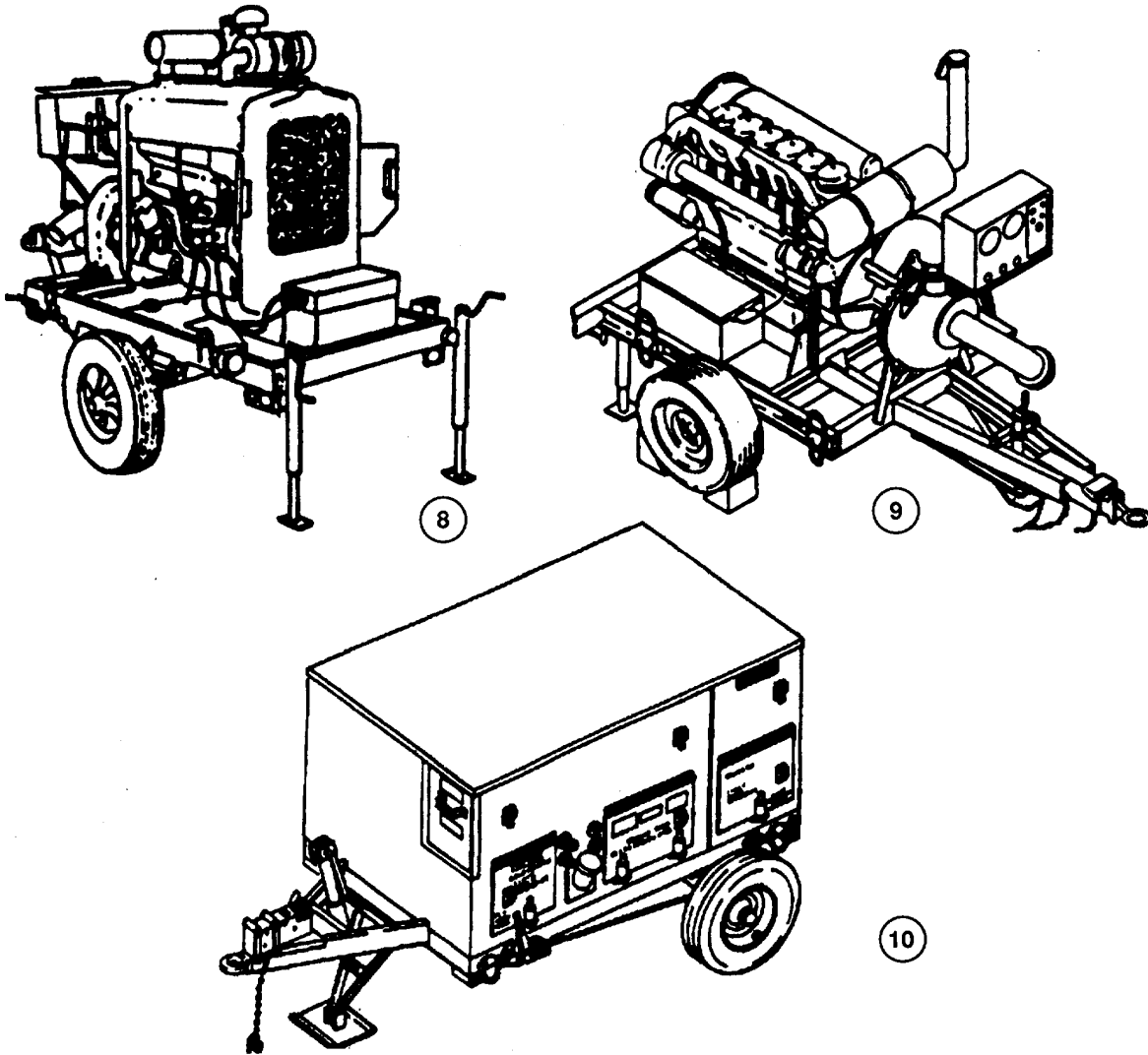
SECTION II. COMPONENTS OF END ITEM



(1) ILLUS NUMBER	(2) NATIONAL STOCK NUMBER	(3) DESCRIPTION CAGEC and Part Number	Usable On Code	(4) U/M	(5) Qty Rqd
1	4730-01-176-5772	PUMPING STATION COUPLING, CLAMP PIPE, 6 INCH (81349) M10387-1-D-11		EA	*
2	4730-01-270-6555	COUPLING, CLAMP, 6 INCH (79154) 6-791-A		EA	*
3	5120-01-270-7428	WRENCH, SPANNER (79154) 792		EA	*
4	4720-01-279-7772	HOSE ASSEMBLY, 6 INCH X 10 FEET (97403) 13225E9088-7		EA	6
5	4720-01-346-7216	HOSE ASSEMBLY, 6 INCH X 20 FEET (97403) 13225E9088-5		EA	6
6	4720-01-276-5952	HOSE ASSEMBLY, 6 INCH X 75 FEET (97403) 13225E9088-6		EA	6
7	4730-01-182-3449	PIPE FITTING, LATERAL GROOVED, 450, 6 INCH (81349) M10388-A18AK1C		EA	12

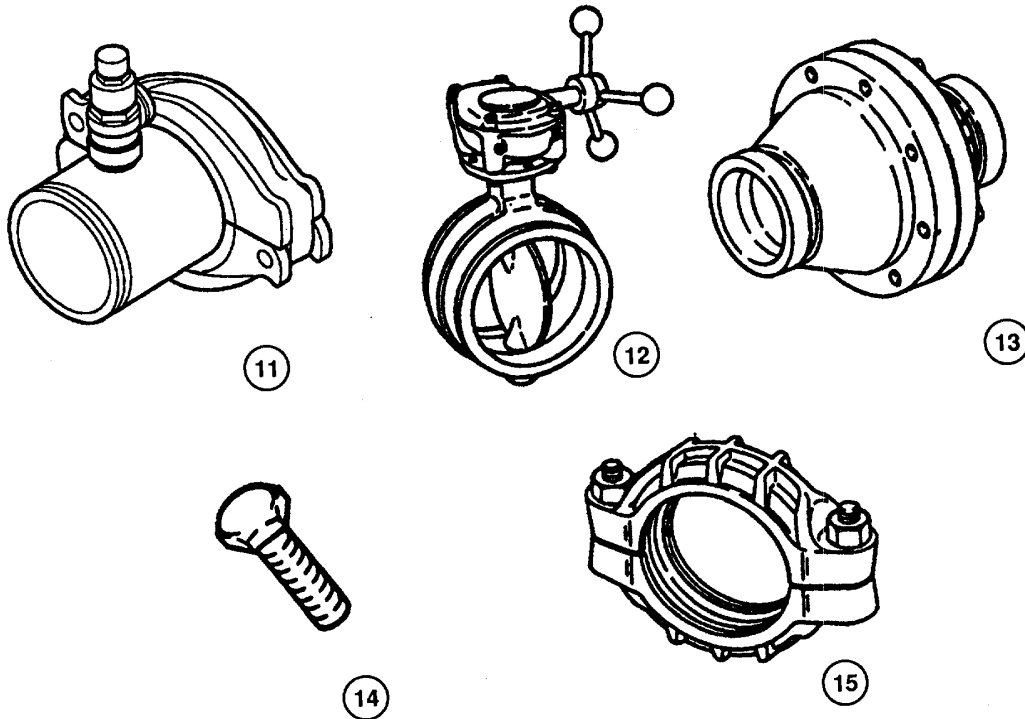
* See note 1 at end of Components of End Item table.

SECTION II. COMPONENTS OF END ITEM



(1) ILLUS NUMBER	(2) NATIONAL STOCK NUMBER	(3) DESCRIPTION CAGEC and Part Number	Usable On Code	(4) U/M	(5) Qty Rqd
8	4320-01-184-7494	PUMPING ASSEMBLY, WATER, 600 GPM, UNIT 609-A (97403) 13225E9088-3	DTC, DTQ	EA	6
9	4320-01-201-6937	PUMPING ASSEMBLY, WATER, 600 GPM, UNIT 609-C (97403) 46121-209	EAM	EA	6
10	4320-01-261-6470	PUMPING ASSEMBLY, WATER, 600 GPM, UNIT US636HCCD-1 (97403) PD80366	DTR	EA	6

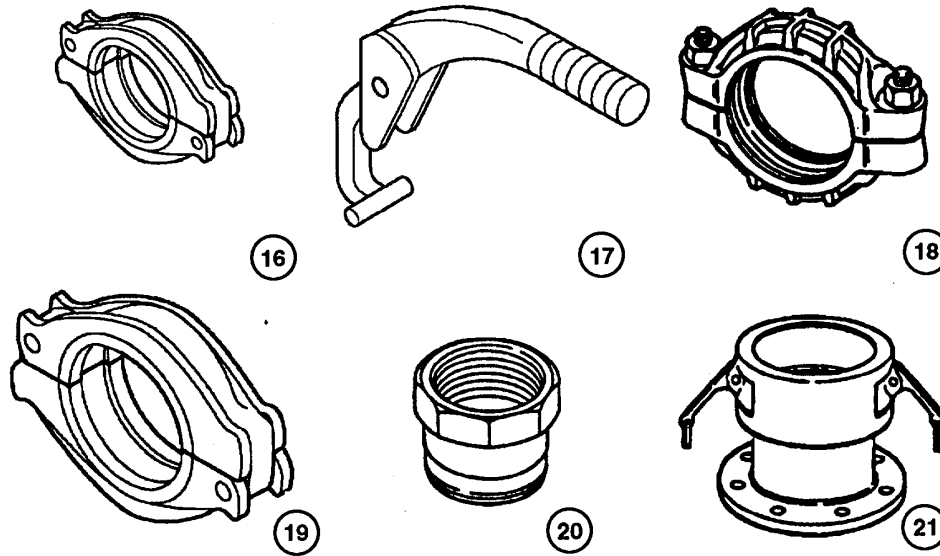
SECTION II. COMPONENTS OF END ITEM (CONTINUED)



(1) ILLUS NUMBER	(2) NATIONAL STOCK NUMBER	(3) DESCRIPTION CAGEC and Part Number	Usable On Code	(4) U/M	(5) Qty Rqd
11	4820-01-201-7138	VALVE ASSEMBLY, PRESSURE RELIEF, 6 INCH (97403) 13225E9196		EA	6
12	4820-01-186-0744	VALVE, BUTTERFLY, 6 INCH, GEAR ACTUATED (79154) 700E6IN		EA	18
13	4820-01-186-0738	VALVE, CHECK, EDPM, 6 INCH (79154) V-060-710-P-E3		EA	6
		STORAGE ASSEMBLIES			
14	5305-00-724-7236	BOLT, 0.375 16 UNC-2A X 3.25 INCHES (80204) B1821BH063C325N		EA	32
15	4730-01-177-5166	COUPLING, CLAMP PIPE, 4 INCH (81349) M10387-1-D-09		EA	*

* See note 2 at end of Components of End Item table.

SECTION II. COMPONENTS OF END ITEM

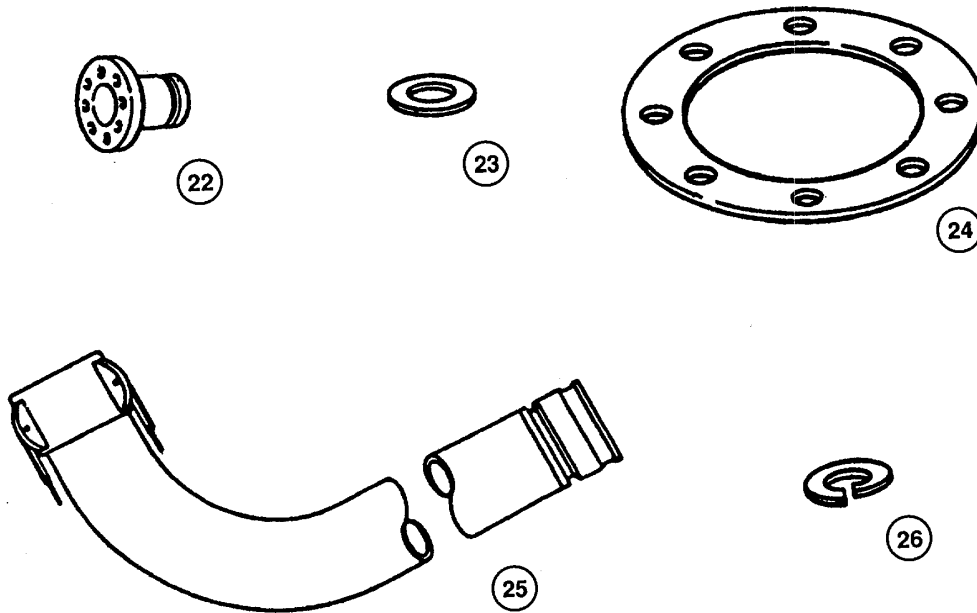


(1) ILLUS NUMBER	(2) NATIONAL STOCK NUMBER	(3) DESCRIPTION CAGEC and Part Number	Usable On Code	(4) U/M	(5) Qty Rqd
16	4730-01-270-6554	COUPLING, CLAMP, 4 INCH (79154) 4-791-A		EA	*
17	5120-01-270-7428	WRENCH, SPANNER (79154) 792		EA	
18	4730-01-176-5772	COUPLING, CLAMP PIPE, 6 INCH (81349) M10387-1-D-11		EA	**
19	4730-01-270-6555	COUPLING, CLAMP, 6 INCH (79154) 6-791-A		EA	**
20	4730-00-840-0796	COUPLING HALF, QUICK DISCONNECT MALE, 4 INCH (96906) MS27020-17		EA	2
21	4730-00-088-9286	COUPLING HALF, QUICK DISCONNECT FLANGED, FEMALE, 4 INCH (96906) MS27027-17		EA	2

* See note 2 at end of Components of End Item table.

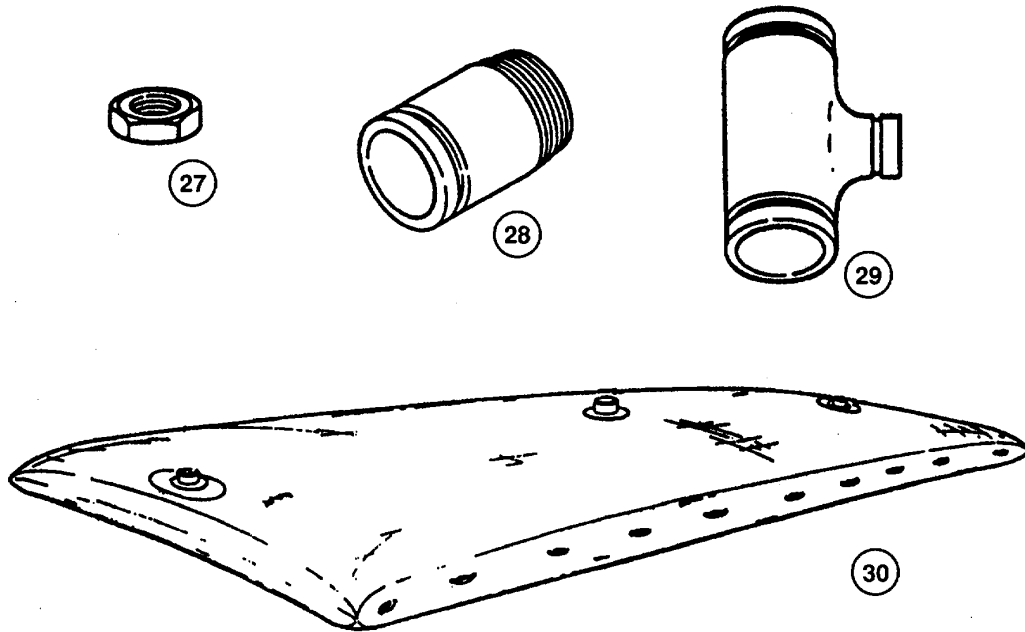
** See note 3 at end of Components of End Item table.

SECTION II. COMPONENTS OF END ITEM (CONTINUED)



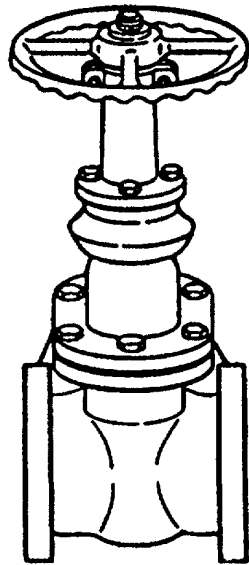
(1) ILLUS NUMBER	(2) NATIONAL STOCK NUMBER	(3) DESCRIPTION CAGEC and Part Number	Usable On Code	(4) U/M	(5) Qty Rqd
22	4730-00-840-5347	COUPLING HALF, QUICK DISCONNECT, 4 INCH, MALE (96906) MS27023-17		EA	2
23	5310-00-823-8803	FLAT WASHER, 0.046 ID X 0.812 OD (96906) MS27183-21		EA	64
24	5330-01-141-1864	GASKET, CLASS 150, 4 INCH NOMINAL (97403) 13220E1069-1		EA	4
25	4720-01-138-8986	HOSE ASSEMBLY, 4 INCH X 10 FEET (97403) 13225E9136-3		EA	8
26	5310-00-004-5034	WASHER, LOCK, 0.375 INCH (26916) 004-003005-059		EA	32

SECTION II. COMPONENTS OF END ITEM

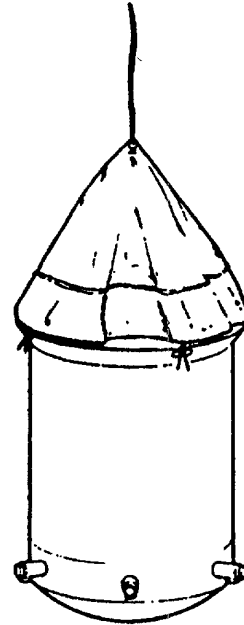


(1) ILLUS NUMBER	(2) NATIONAL STOCK NUMBER	(3) DESCRIPTION CAGEC and Part Number	Usable On Code	(4) U/M	(5) Qty Rqd
27	5310-00-763-8920	NUT, PLAIN, HEXAGON, 0.375 16 UNC-2B (96906) MS51967-20		EA	32
28		PIPE, FITTING, COUPLING, 4 INCH (81349) M10388-A07A11A6A		EA	2
29	4730-01-180-4057	TEE, PIPE, 6 X 6 X 4 INCH (81349) M10388-A-30-EB-1-A-6C		EA	2
30	5430-01-106-9678	TANK, STORAGE, 20,000 GALLONS (81349) M53029-20		EA	2

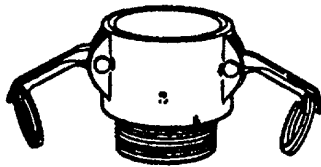
SECTION II. COMPONENTS OF END ITEM (CONTINUED)



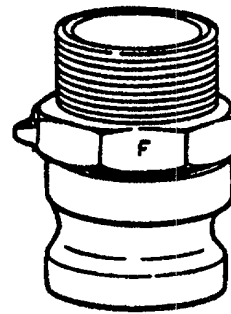
31



32



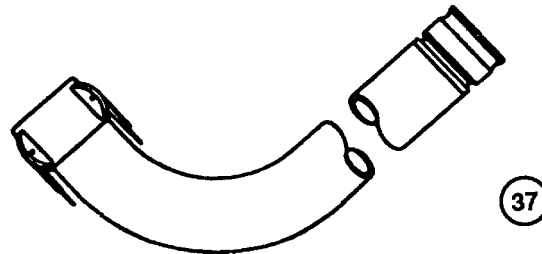
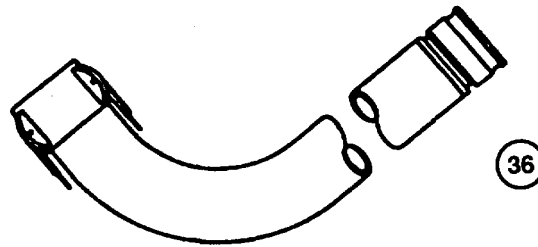
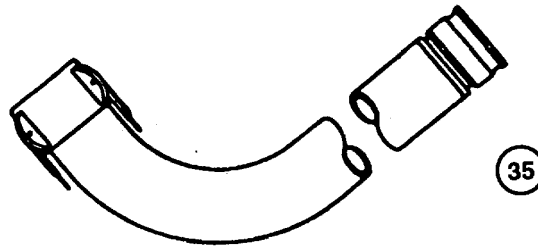
33



34

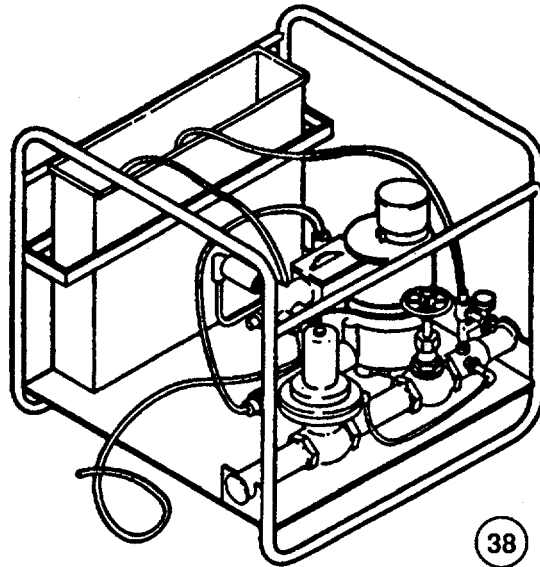
(1) ILLUS NUMBER	(2) NATIONAL STOCK NUMBER	(3) DESCRIPTION CAGEC and Part Number	Usable On Code	(4) U/M	(5) Qty Rqd
31	4820-01-159-0439	VALVE, GATE, 4 INCH, FLANGED (81718) OPW-676-FR4W DISTRIBUTION POINTS		EA	2
32	4610-01-117-8271	BAG, DRINKING WATER STORAGE, 36 GALLONS (81349) MIL-B-273		EA	4
33	4730-00-088-9285	COUPLING HALF, QUICK DISCONNECT (96906) MS27026-11		EA	6
34	4730-00-938-7997	COUPLING HALF, QUICK DISCONNECT (96906) MS27022-11		EA	6

SECTION II. COMPONENTS OF END ITEM

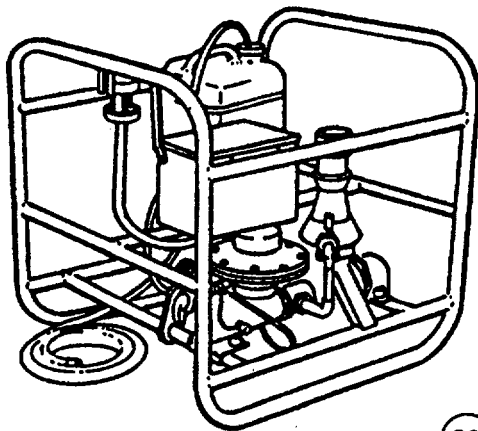


(1) ILLUS NUMBER	(2) NATIONAL STOCK NUMBER	(3) DESCRIPTION CAGEC and Part Number	Usable On Code	(4) U/M	(5) Qty Rqd
35	4720-01-163-3088	HOSE ASSEMBLY, 2 INCH X 10 FEET (97403) 13225E9136-1		EA	2
36	4720-01-138-8986	HOSE ASSEMBLY, 2 INCH X 20 FEET (97403) 13225E9136-2		EA	14
37	4720-01-163-4684	HOSE ASSEMBLY, 2 INCH X 20 FEET (97403) 13225E9135-2		EA	2

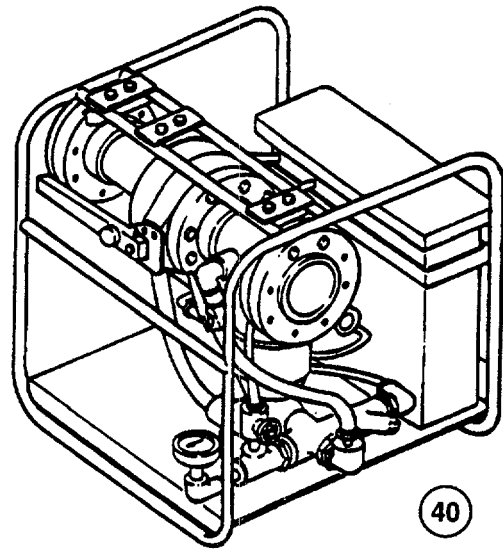
SECTION II. COMPONENTS OF END ITEM (CONTINUED)



38



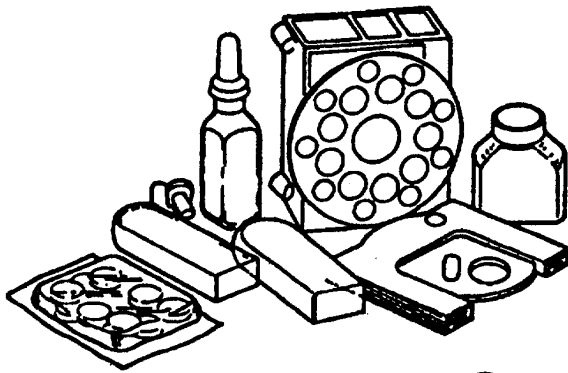
39



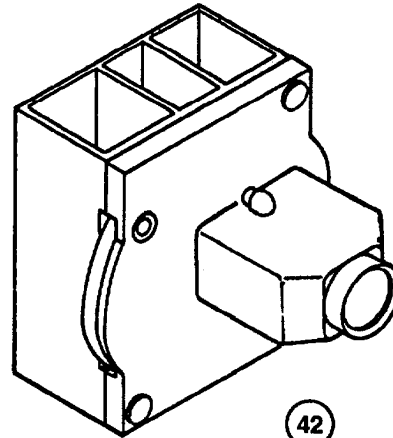
40

(1) ILLUS NUMBER	(2) NATIONAL STOCK NUMBER	(3) DESCRIPTION CAGEC and Part Number	Usable On Code	(4) U/M	(5) Qty Rqd
38	4610-00-937-6862	HYPOCHLORINATION UNIT, 1955-1 (09680) MIL-H-12732	DTC, DTR	EA	2
39		HYPOCHLORINATION UNIT, A-506131 (79172) A-506131	DTQ	EA	2
40	4610-01-250-3724	HYPOCHLORINATION UNIT, 1955-3 (31922) 1955-3	EAM	EA	2

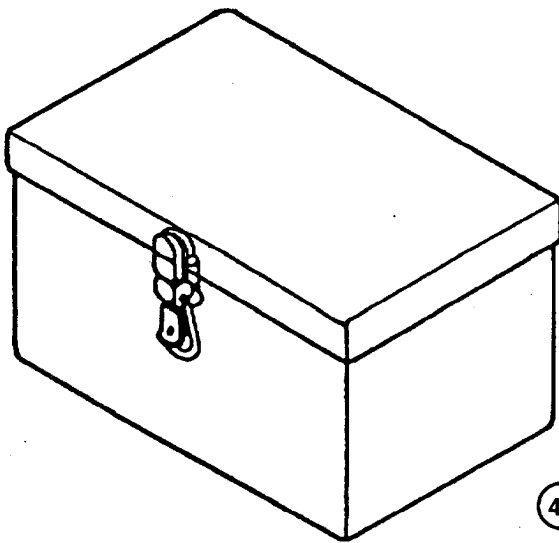
SECTION II. COMPONENTS OF END ITEM



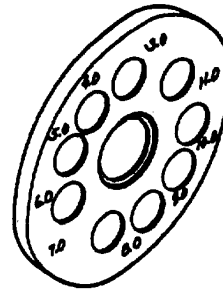
41



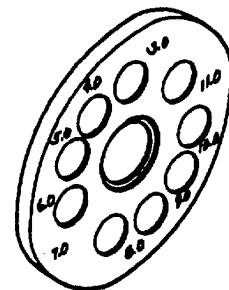
42



43



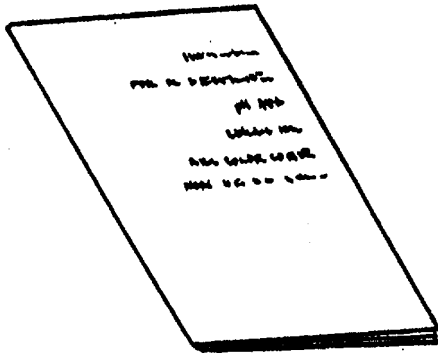
44



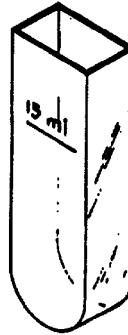
45

(1) ILLUS NUMBER	(2) NATIONAL STOCK NUMBER	(3) DESCRIPTION CAGEC and Part Number	Usable On Code	(4) U/M	(5) Qty Rqd
41	6630-01-044-0334	KIT, COMPARATOR, COLOR (12308) U25337		EA	2
42	6630-01-336-9215	COLOR COMPARATOR (97403) 13200E7400		EA	2
43		CONTAINER, KIT (97403) 13216E9016		EA	2
44		DISC, CHLORINE		EA	2
45		DISC, pH		EA	2

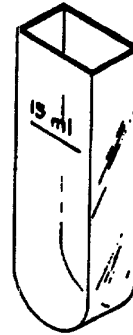
SECTION II. COMPONENTS OF END ITEM (CONTINUED)



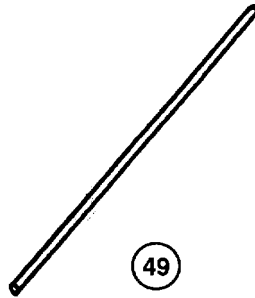
46



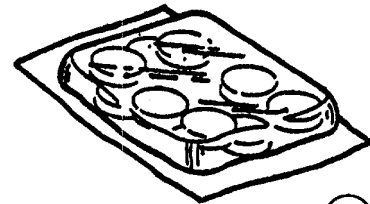
47



48



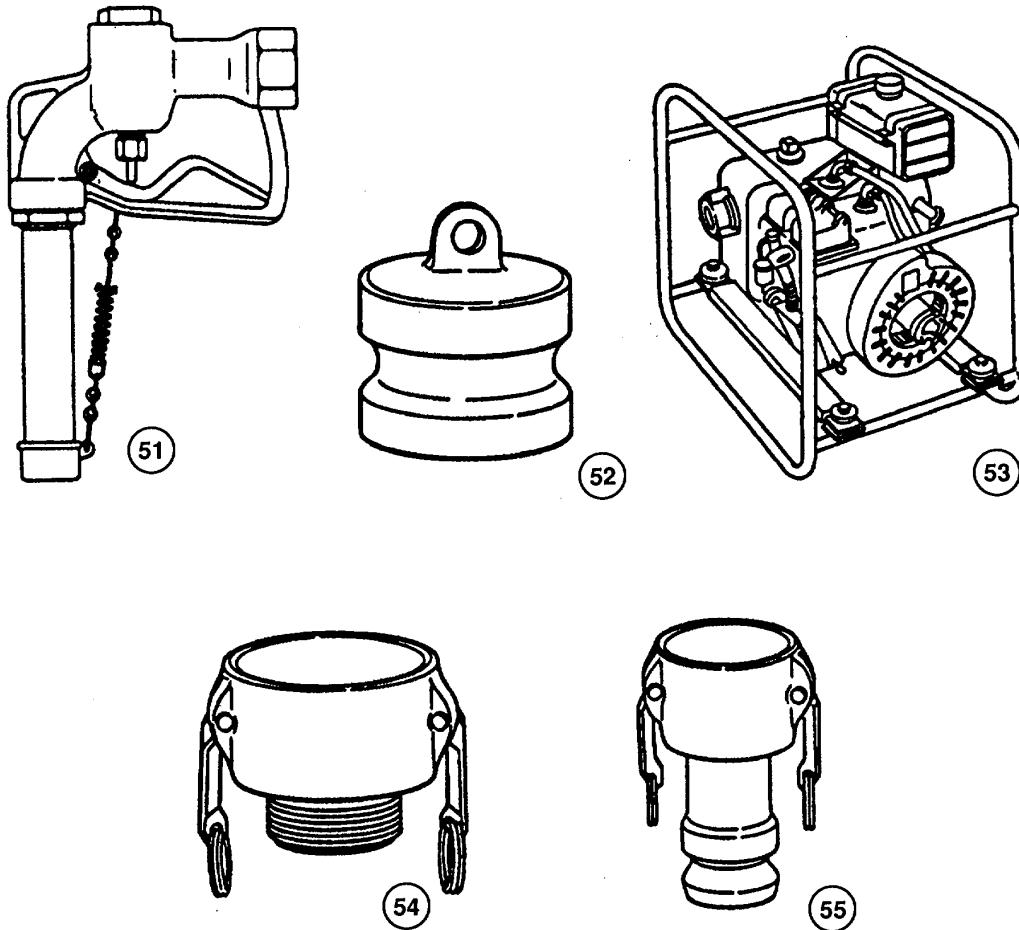
49



50

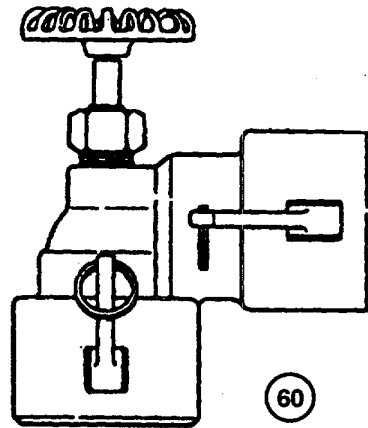
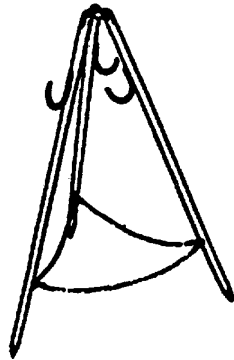
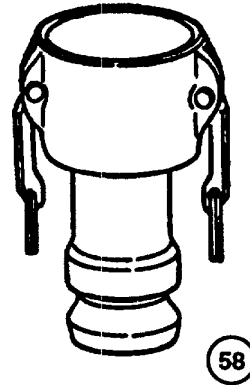
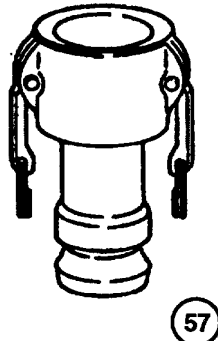
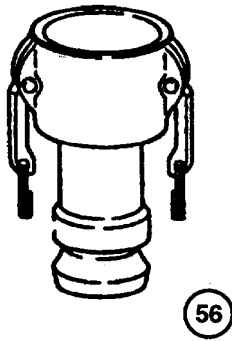
(1) ILLUS NUMBER	(2) NATIONAL STOCK NUMBER	(3) DESCRIPTION CAGEC and Part Number	(4) Usable U/M On Code	(5) Qty Rqd
46		INSTRUCTIONS	EA	2
47		SAMPLE CELLS	EA	4
48		SOLUTION, pH, 4 OUNCE	OZ	2
49		STIRRING ROD	EA	2
50		TABLETS, DPD	BX	2

SECTION II. COMPONENTS OF END ITEM



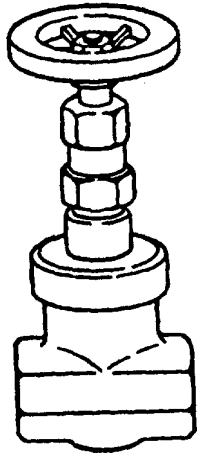
(1) ILLUS NUMBER	(2) NATIONAL STOCK NUMBER	(3) DESCRIPTION CAGEC and Part Number	Usable On Code	(4) U/M	(5) Qty Rqd
51	2910-01-188-8198	NOZZLE, 1-¼ INCH (81718) 190-GW		EA	4
52	4730-00-915-5127	PLUG, DUST, QUICK-DISCONNECT, 200-DP (96906) MS27029-11		EA	4
53	4320-00-542-3347	125 GPM PUMPING ASSEMBLY (97403) 13200E8800		EA	2
54	4730-01-192-1624	COUPLING HALF, QUICK-DISCONNECT (96906) MS49002-9		EA	4
55	4730-00-951-3297	REDUCER, QUICK-DISCONNECT (96906) MS49000-5		EA	4

SECTION II. COMPONENTS OF END ITEM (CONTINUED)

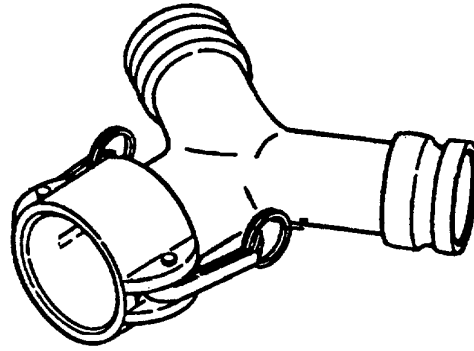


(1) ILLUS NUMBER	(2) NATIONAL STOCK NUMBER	(3) DESCRIPTION CAGEC and Part Number	Usable On Code	(4) U/M	(5) Qty Rqd
56	4730-00-951-3297	REDUCER, QUICK-DISCONNECT (96906) MS49000-11		EA	2
57	4730-01-186-0821	REDUCER, QUICK-DISCONNECT (96906) MS49000-19		EA	4
58	4730-01-064-0560	REDUCER, QUICK-DISCONNECT (96906) MS49000-17		EA	4
59	4930-01-120-7426	STAND ASSEMBLY, NOZZLE (97403) 13225E9140		EA	4
60	4820-01-167-6550	VALVE, ELBOW COUPLER, 2 INCH X 2 INCH (97403) 13219E0491		EA	4

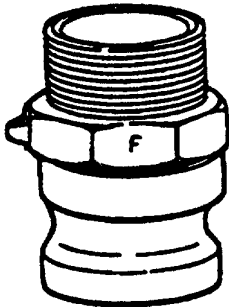
SECTION II. COMPONENTS OF END ITEM



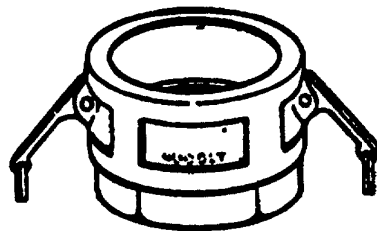
61



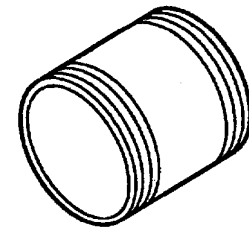
62



63



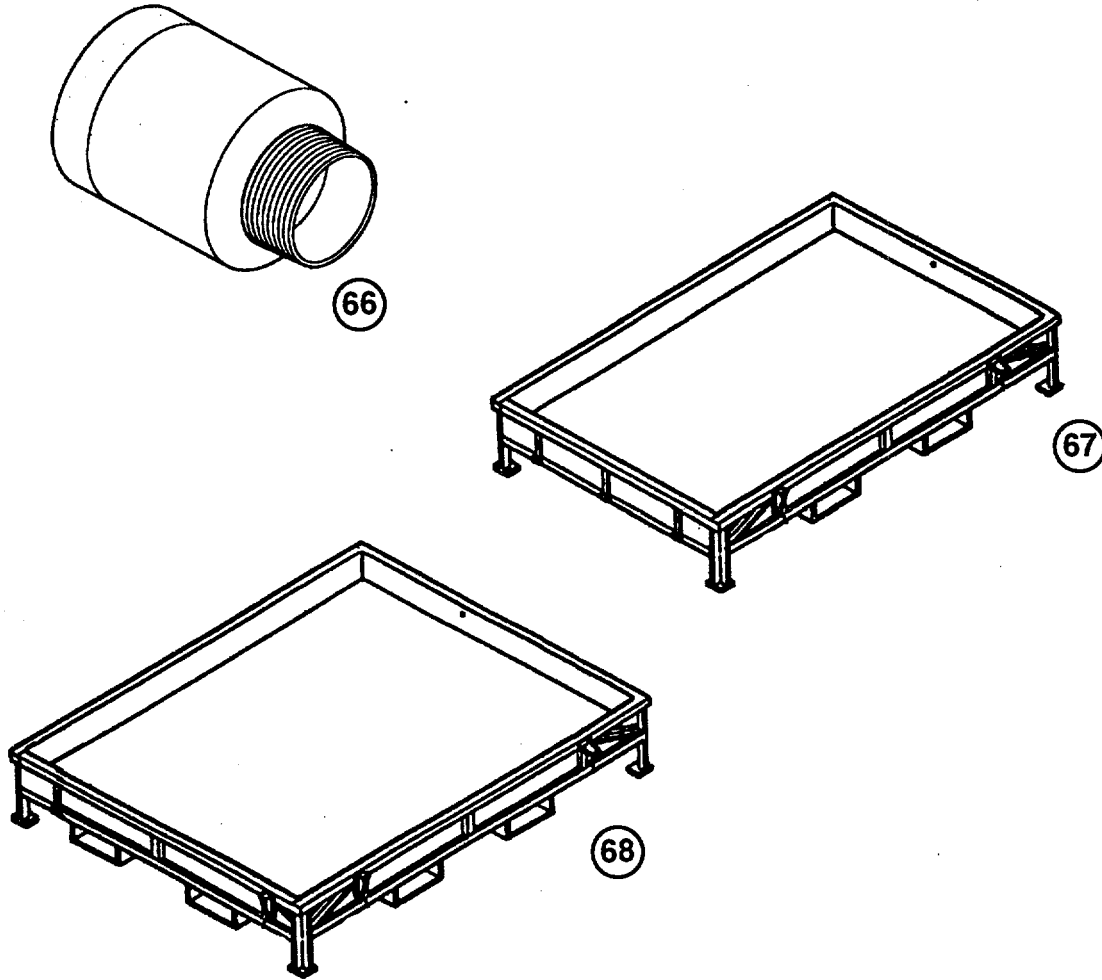
64



65

(1) ILLUS NUMBER	(2) NATIONAL STOCK NUMBER	(3) DESCRIPTION CAGEC and Part Number	Usable On Code	(4) U/M	(5) Qty Rqd
61	4820-00-810-4250	VALVE, GATE, 2 INCH (82666) B120-2"		EA	4
62	4730-01-068-5070	WYE, CONNECTION, QUICK-DISCONNECT (81718) 319K-2IN		EA	6
63	4730-00-840-0797	COUPLING HALF, QUICK DISCONNECT, MALE (96906) MS 27022-17		EA	2
64	4730-00-088-9286	COUPLING HALF, QUICK DISCONNECT, FEMALE (96906) MS 27024-17		EA	2
65		NIPPLE, 4 INCH DIAMETER, 6 INCHES LONG (81348) WW-N-351		EA	2

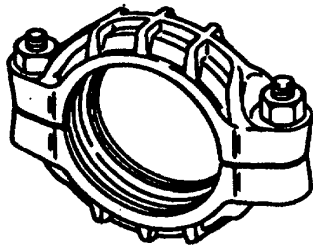
SECTION II. COMPONENTS OF END ITEM (CONTINUED)



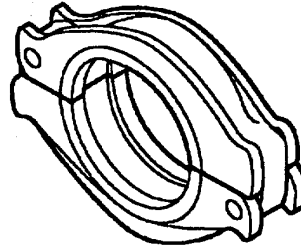
(1) ILLUS NUMBER	(2) NATIONAL STOCK NUMBER	(3) DESCRIPTION CAGEC and Part Number	Usable On Code	(4) U/M	(5) Qty Rqd
66		SWIVEL, HOSE (97403) 13225E9139-3 10-MILE HOSELINE SEGMENT		EA	4
67	4720-01-257-1423	BOX, FLAKING, 2-WAY (97403) 13225E9182-1		EA	*
68		ASSEMBLY, FLAKING BOX (97403) 13227E9787		EA	*

*See note 4 at end of Components of End Item table.

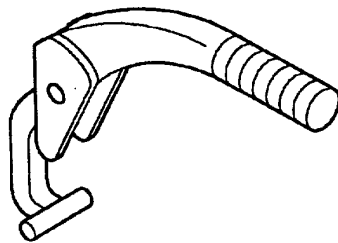
SECTION II. COMPONENTS OF END ITEM



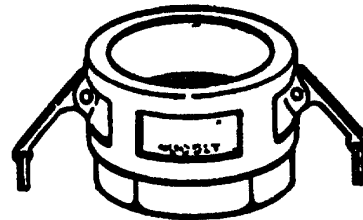
69



70



71

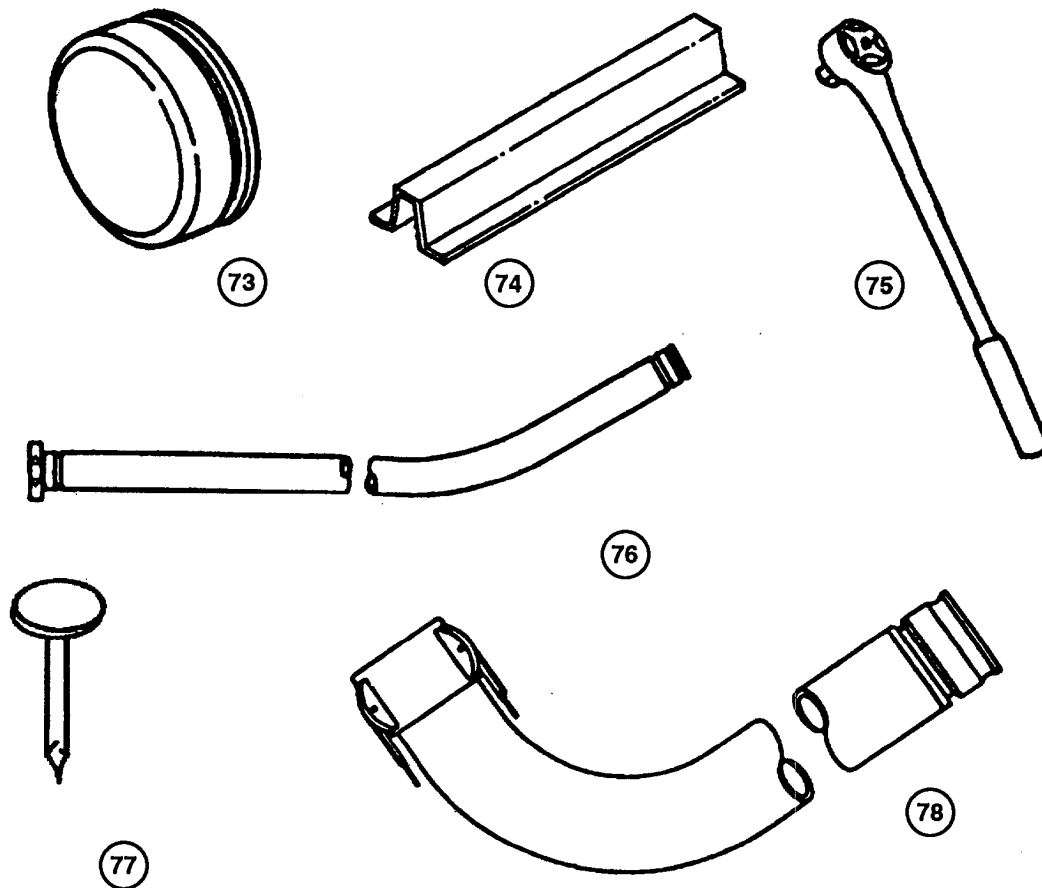


72

(1) ILLUS NUMBER	(2) NATIONAL STOCK NUMBER	(3) DESCRIPTION CAGEC and Part Number	Usable On Code	(4) U/M	(5) Qty Rqd
69	4730-01-176-5772	COUPLING, CLAMP PIPE, 6 INCH (82349) M10387-1-D-11		EA	
70	4730-01-270-6555	COUPLING, CLAMP, 6 INCH (79154) 6-791-A		EA	
71	5120-01-270-7428	WRENCH, SPANNER (79154) 792		EA	
72	4730-01-186-0817	COUPLING HALF, QUICK DISCONNECT, FEMALE, 6 INCH (96906) MS27024-19		EA	1

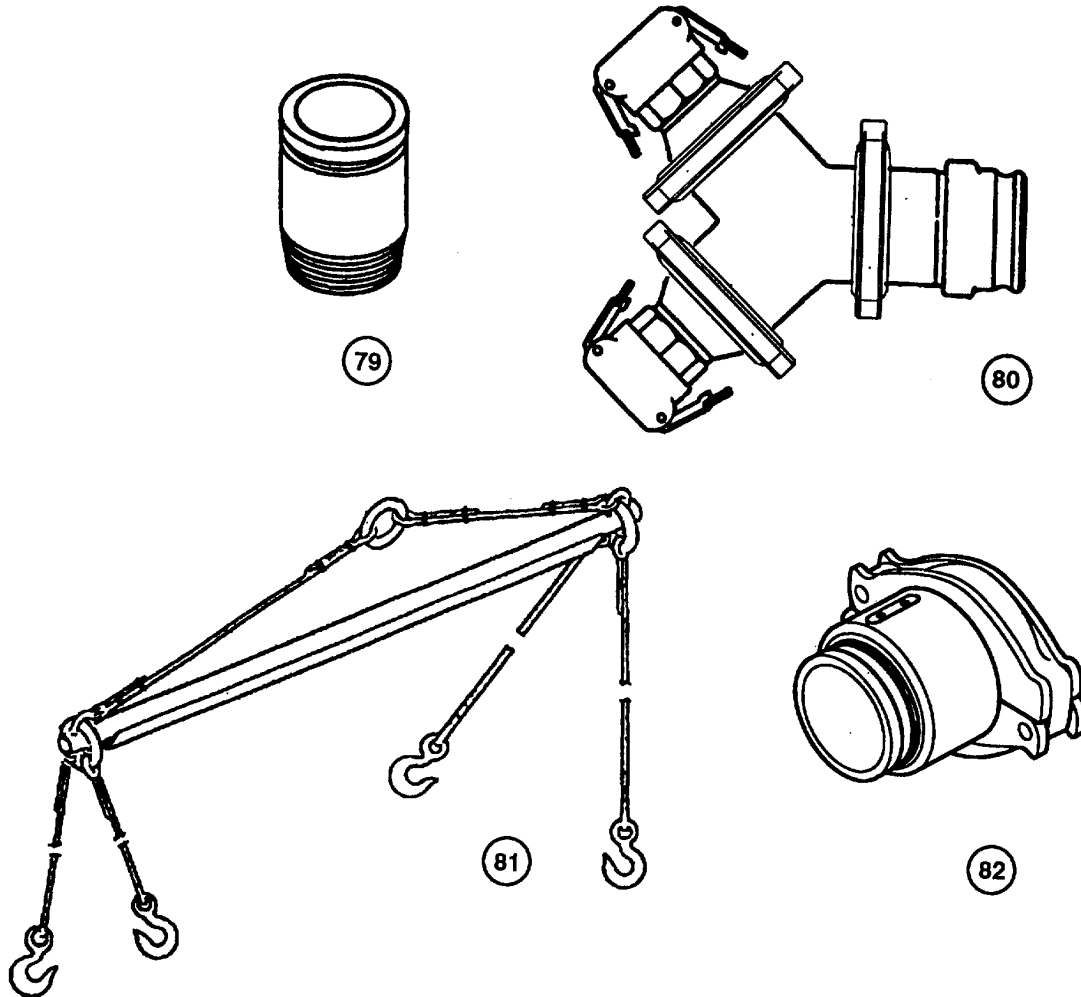
*See note 5 at end of Components of End Item table.

SECTION II. COMPONENTS OF END ITEM (CONTINUED)



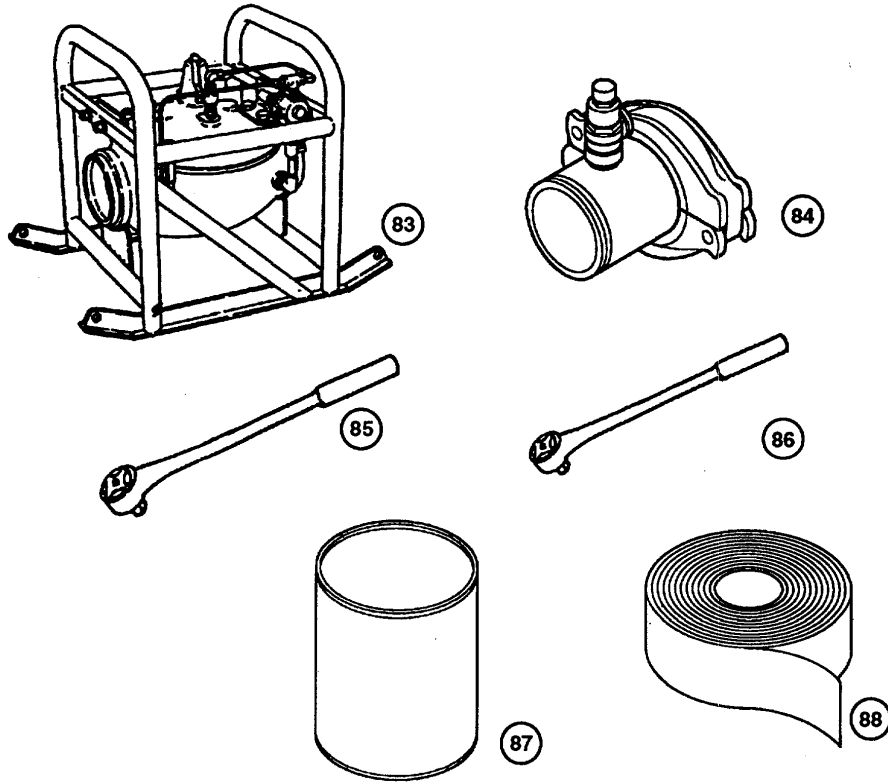
(1) ILLUS NUMBER	(2) NATIONAL STOCK NUMBER	(3) DESCRIPTION CAGEC and Part Number	Usable On Code	(4) U/M	(5) Qty Rqd
73		END CAP, GROOVED PIPE, 6 INCH (81349) M10388-A05AK1A		EA	1
74	3835-01-187-1556	GUARD, ROAD CROSSING, 6 INCH (97403) 13226E1576		EA	24
75	5120-00-249-1076	HANDLE, SOCKET WRENCH (77053) 9649		EA	4
76	4720-01-346-7216	HOSE ASSEMBLY, COLLAPSIBLE, 6 INCH X 500 FEET (97403) M53027-5000		EA	128
77		NAILS, STEEL ROOFING, 1-½ INCH (96906) MS90714-8B		EA	240
78	4720-01-163-4686	HOSE ASSEMBLY, 6 INCH X 10 FEET (97403) 13225E9135-6		EA	12

SECTION II. COMPONENTS OF END ITEM



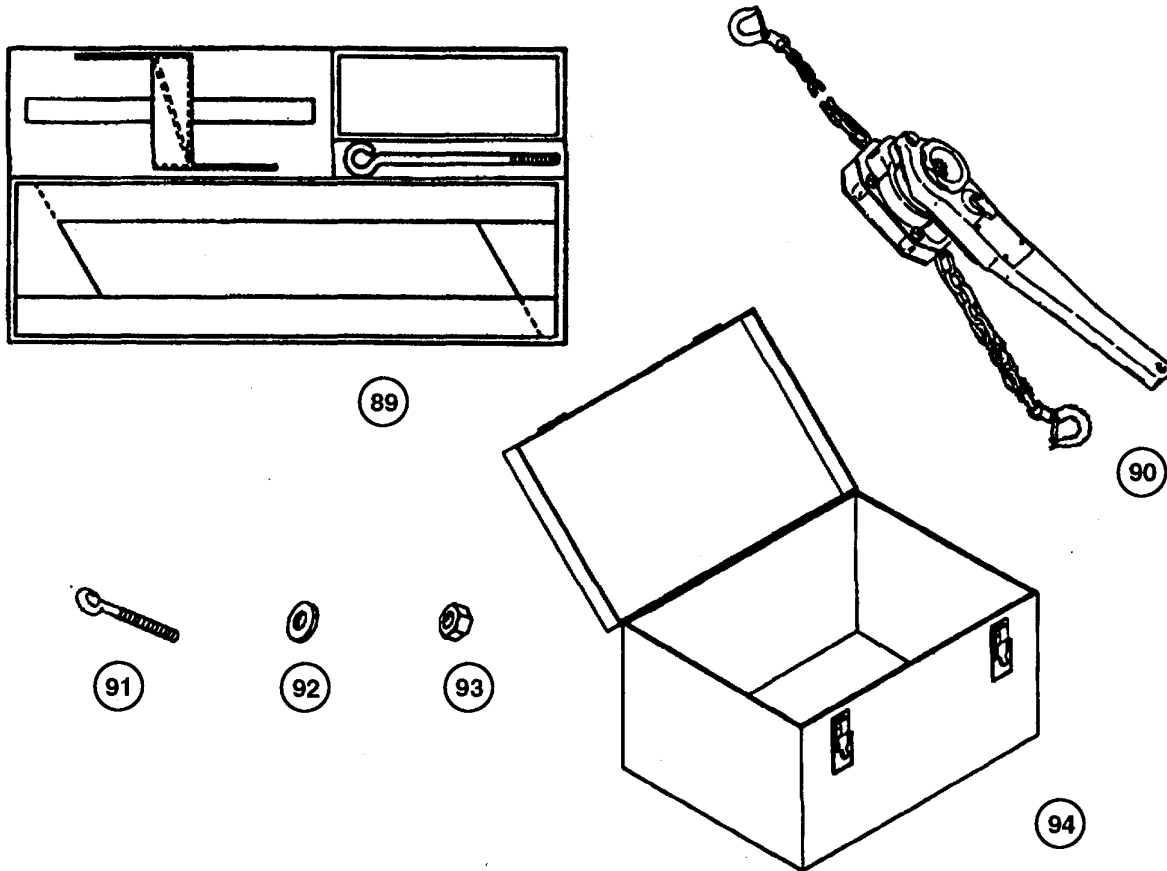
(1) ILLUS NUMBER	(2) NATIONAL STOCK NUMBER	(3) DESCRIPTION CAGEC and Part Number	(4) Usable U/M On Code	(5) Qty Rqd
79		PIPE FITTING, COUPLING, 6 IN. (81349) M10388-A07AKIA6A	EA	1
80		REDUCER, Y-CONNECTION, 6 X 4 X 4 IN. (97403) 13225E9190	EA	1
81	3940-01-199-4010	SLING, MULTIPLE (97403) 13226E1582	EA	1
82		SWIVEL JOINT ASSY, 6 INCH (97403) 13225E9195	EA	65

SECTION II. COMPONENTS OF END ITEM (CONTINUED)



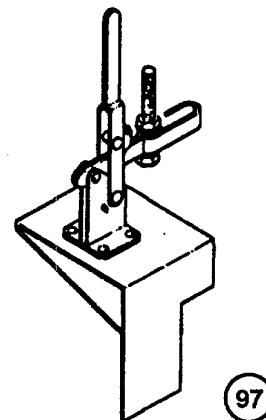
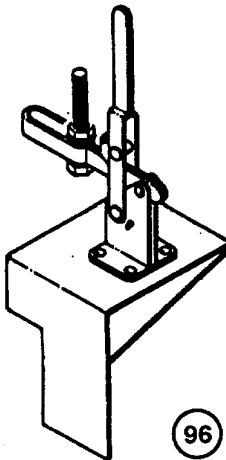
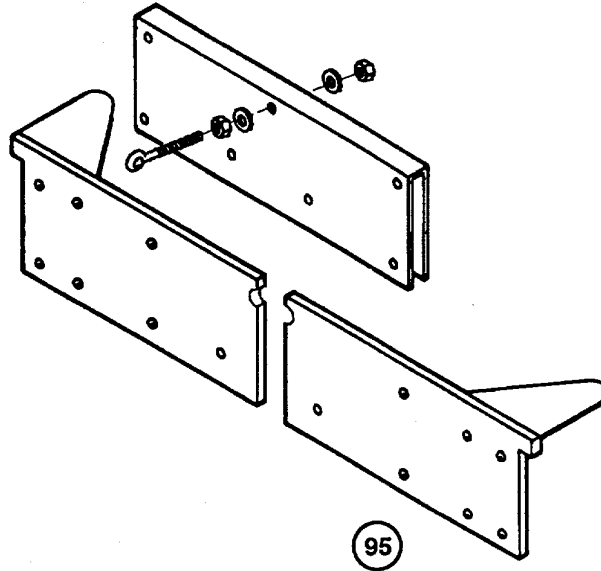
(1) ILLUS NUMBER	(2) NATIONAL STOCK NUMBER	(3) DESCRIPTION CAGEC and Part Number	Usable On Code	(4) U/M	(5) Qty Rqd
83	4820-01-264-6203	VALVE ASSEMBLY, PRESSURE REDUCING (97403) 13225E9090-13		EA	1
84	4820-01-201-7138	VALVE ASSEMBLY, PRESSURE RELIEF (97403) 13225E9196		EA	1
85		WRENCH, SOCKET, 1-¼ INCH (81348) GGG-W-641, TYPE II, CLASS 2		EA	2
86		WRENCH, SOCKET, 1-1/16 INCH (81348) GGG-W-641, TYPE I, CLASS 2		EA	2
87		LUBRICANT, GASKET, ONE-QUART CAN (97403) 13225E9192		EA	2
88	8030-00-889-3535	TAPE, ANTISEIZE, PTFE (80244) P5025-2R		EA	AR

SECTION II. COMPONENTS OF END ITEM



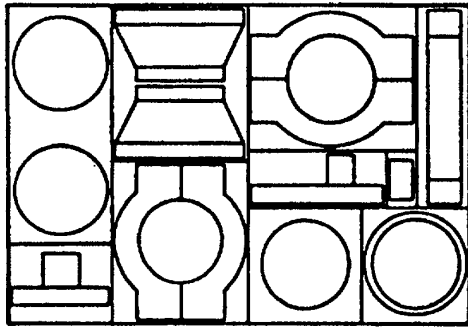
(1) ILLUS NUMBER	(2) NATIONAL STOCK NUMBER	(3) DESCRIPTION CAGEC and Part Number	Usable On Code	(4) U/M	(5) Qty Rqd
89		PACKING KIT, HOSELINE, 6 IN.			
90		CHAIN HOIST (81349) MIL-H-904		EA	1
91	5306-00-141-7179	BOLT, EYE (96906) MS27950-8		EA	2
92	5310-00-809-5998	WASHER, FLAT (96906) MS27183-18		EA	4
93	5310-01-338-7322	NUT, PLAIN, HEXAGON (96906) MS51967-14		EA	4
94		KIT CHEST, METAL		EA	1

SECTION II. COMPONENTS OF END ITEM (CONTINUED)

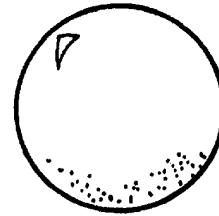


(1) ILLUS NUMBER	(2) NATIONAL STOCK NUMBER	(3) DESCRIPTION CAGEC and Part Number	Usable On Code	(4) U/M	(5) Qty Rqd
95	4610-01-355-8567	PULLBOARD ASSEMBLY (97403) 13226E1572		EA	2
96		HOSE RETAINING BRACKET, LEFT HAND (97403) 13225E9186		EA	2
97	5340-01-359-5640	HOSE RETAINING BRACKET, RIGHT HAND (97403) 13225E9187		EA	2

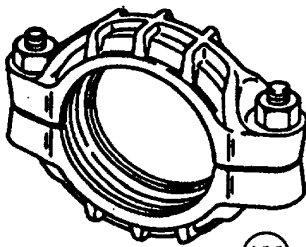
SECTION II. COMPONENTS OF END ITEM (CONTINUED)



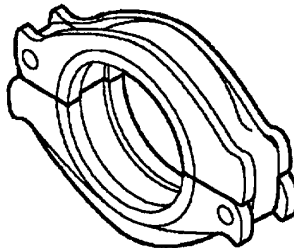
98



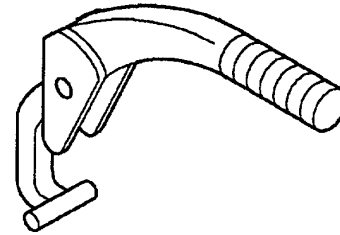
99



100



101

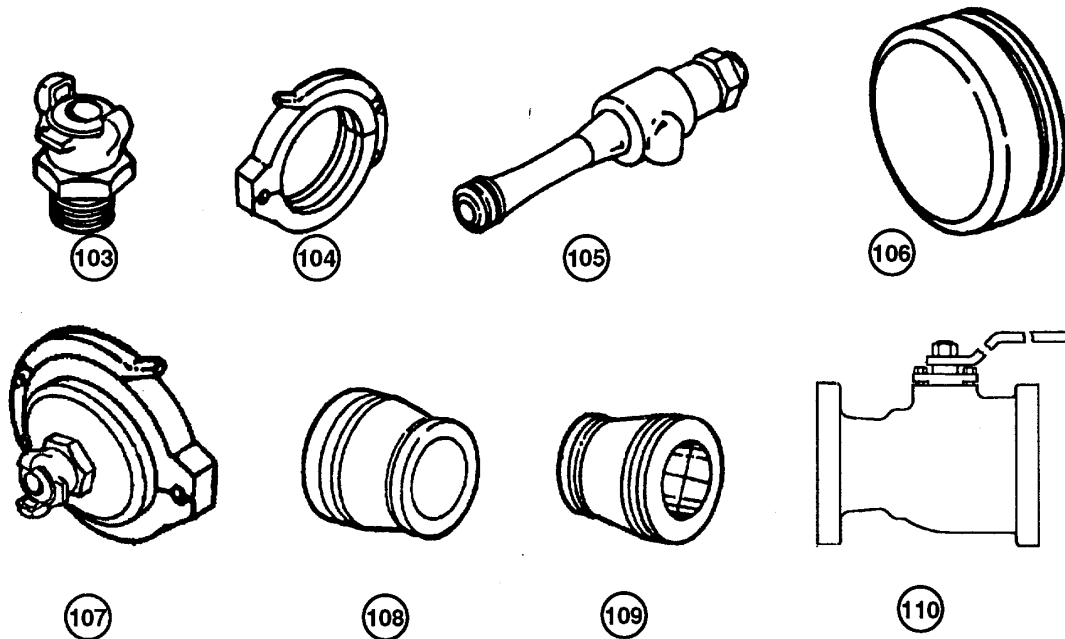


102

(1) ILLUS NUMBER	(2) NATIONAL STOCK NUMBER	(3) DESCRIPTION CAGEC and Part Number	Usable On Code	(4) U/M	(5) Qty Rqd
98		DISPLACEMENT AND EVACUATION KIT			
99		BALL, DISPLACEMENT, HOSELINE (97403) 13228E9872		EA	4
100	4730-01-176-5772	COUPLING, CLAMP PIPE, 6 INCH (81349) M10387-1-D-11		EA	*
101	4730-01-270-6555	COUPLING, CLAMP, 6 INCH (79154) 6-791-A		EA	*
102	5120-01-270-7428	WRENCH, SPANNER (79154) 792		EA	*

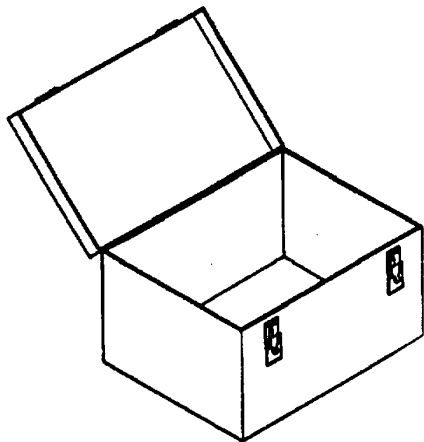
*See note 6 at end of Components of End Item table.

SECTION II. COMPONENTS OF END ITEM (CONTINUED)

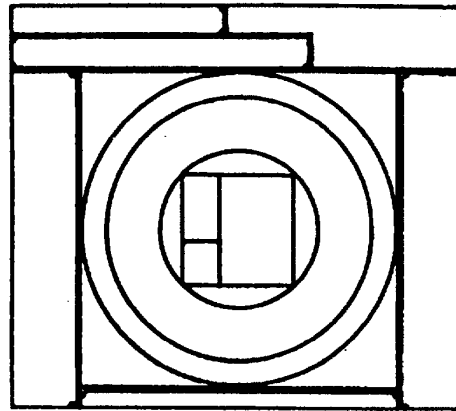


(1) ILLUS NUMBER	(2) NATIONAL STOCK NUMBER	(3) DESCRIPTION CAGEC and Part Number	Usable On Code	(4) U/M	(5) Qty Rqd
103	4730-00-844-9014	COUPLING HALF, QUICK DISCONNECT, PNEUMATIC (81348) WW-C-633-10-B		EA	4
104		COUPLER, SNAPJOINT, PIPE, 8 INCH (97403) 13226E1575-10		EA	2
105	4320-01-212-9621	EJECTOR ASSEMBLY (89117) GL-1		EA	2
106	4730-01-178-0317	CAP, PIPE, 6 INCH (81349) M10388-A05AKIC		EA	48
107		BALL INLET ASSEMBLY (97403) 13225E9198		EA	2
108	4730-01-350-3773	REDUCER, GROOVED PIPE, 8 INCH X 6 INCH (79154) 50A8X6		EA	2
109	4730-01-350-3773	REDUCER, GROOVED PIPE, 8 INCH X 6 INCH, MODIFIED AS BALL RECEIVER (79154) 50A8X6		EA	2
110		VALVE, BALL, 1 INCH NPT (81348) WW-V-35, TYPE II, COMP BZ, ST 3		EA	1

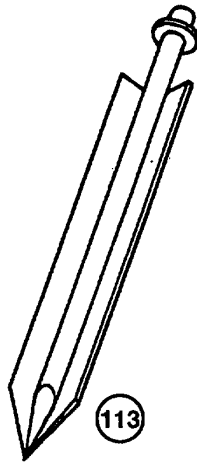
SECTION II. COMPONENTS OF END ITEM



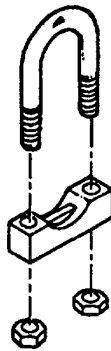
111



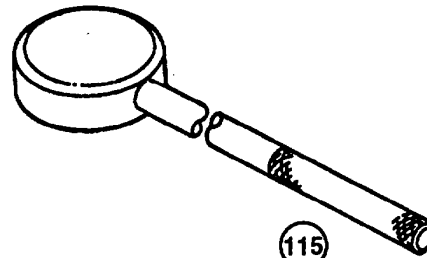
112



113



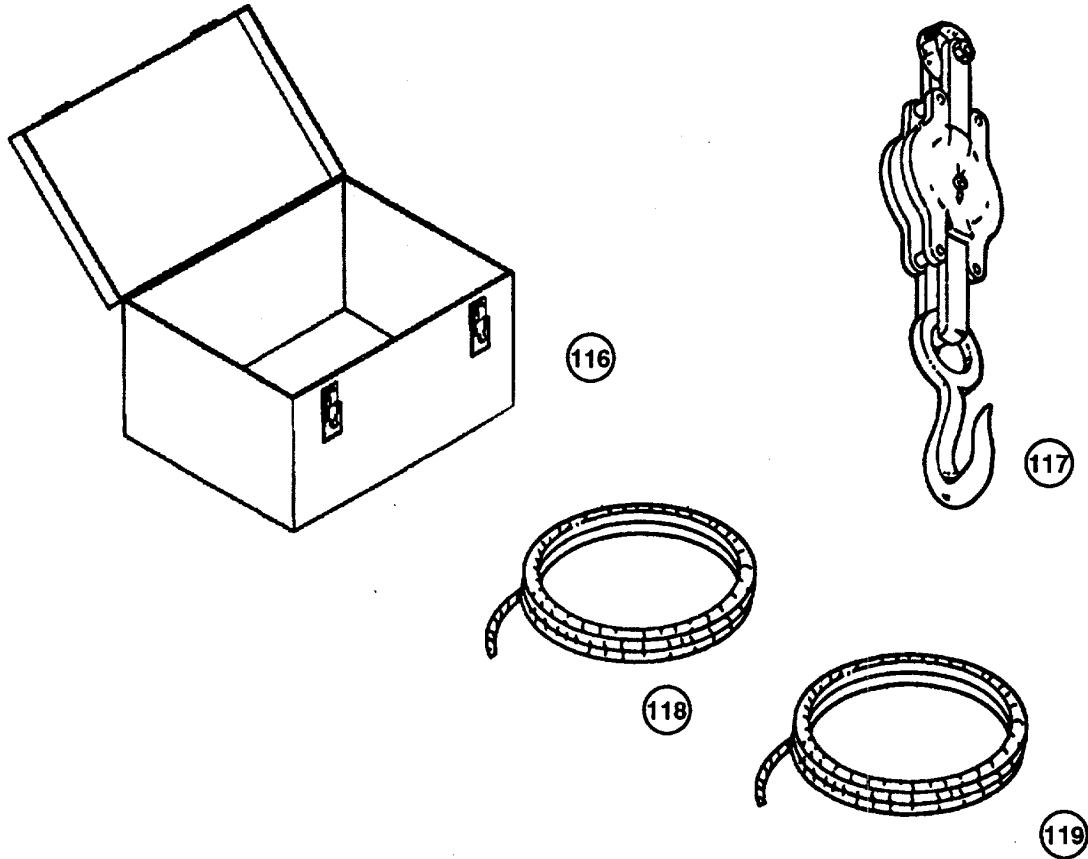
114



115

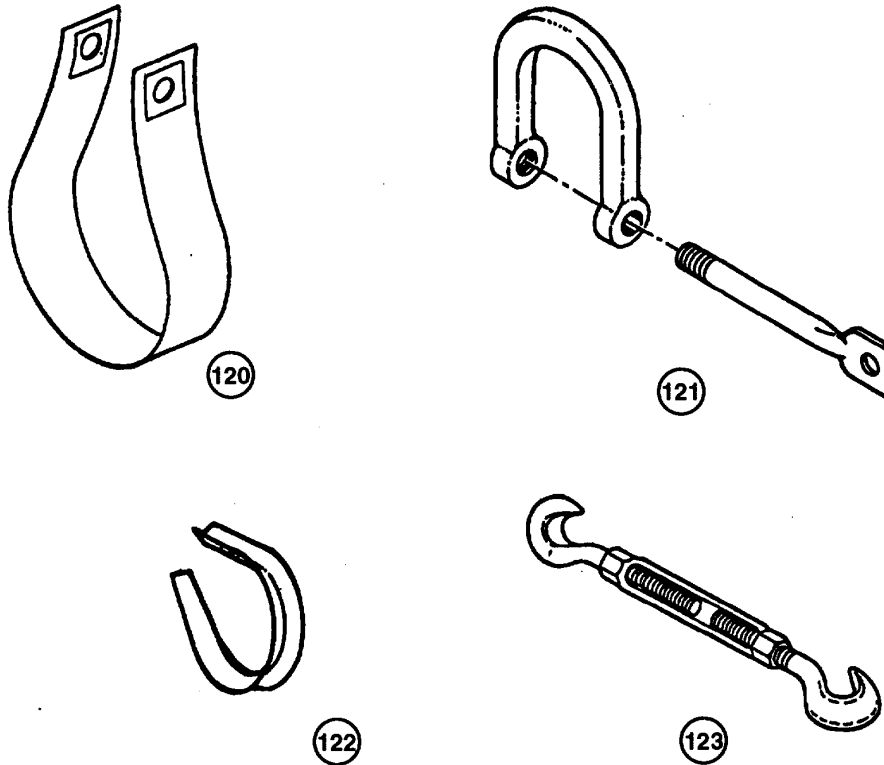
(1) ILLUS NUMBER	(2) NATIONAL STOCK NUMBER	(3) DESCRIPTION CAGEC and Part Number	Usable On Code	(4) U/M	(5) Qty Rqd
111		KIT, CHEST, METAL (63317) 100-04-011		EA	2
112		SUSPENSION KIT, HOSELINE, 6 INCH			
113	4030-01-206-5035	STAKE, GUY (97403) 13225E9188		EA	70
114	4030-01-259-2504	CLAMP, WIRE ROPE (71741) FF-C-450 TY 1 CL 2		EA	125
115		STAKE, DRIVING HEAD (97403) 13225E9189		EA	5

SECTION II. COMPONENTS OF END ITEM (CONTINUED)



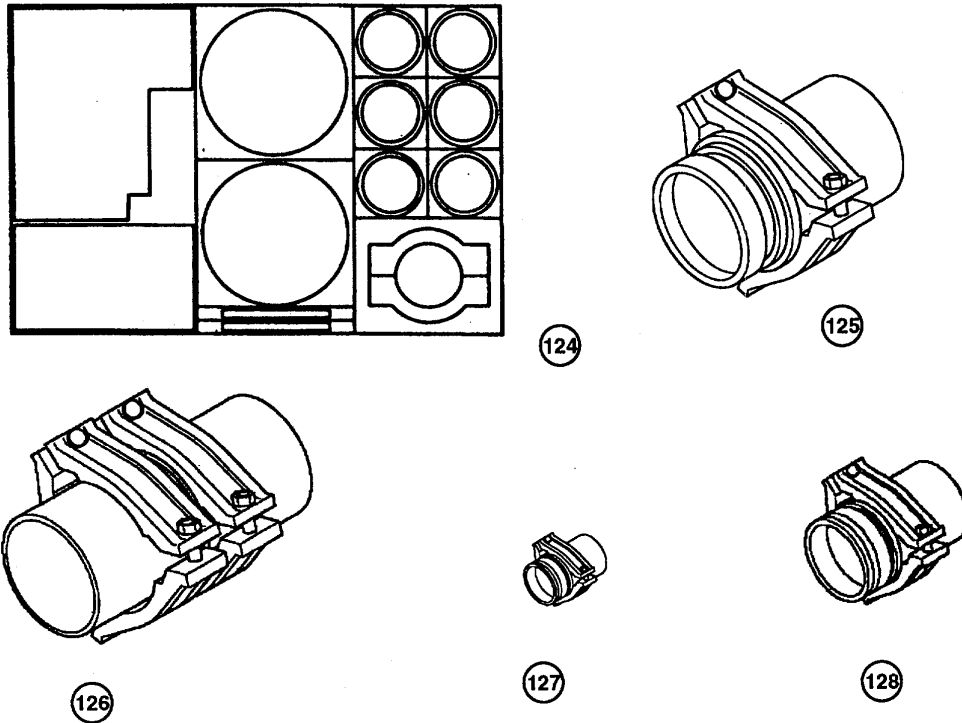
(1) ILLUS NUMBER	(2) NATIONAL STOCK NUMBER	(3) DESCRIPTION CAGEC and Part Number	Usable On Code	(4) U/M	(5) Qty Rqd
116		KIT CHEST, METAL (81348) PPP-B-636		EA	5
117		SNATCH BLOCK (81348) GGG-B-490 TYPE II, SINGLE SHEAVE		EA	20
118		ROPE, MANILA, ½ IN. X 300 FT (81349) T-R-605, TYPE M, CLASS 5		EA	5
119	4010-00-542-2257	ROPE, WIRE (81349) RR-W-410, TYPE 1, CLASS 2		EA	5

SECTION II. COMPONENTS OF END ITEM



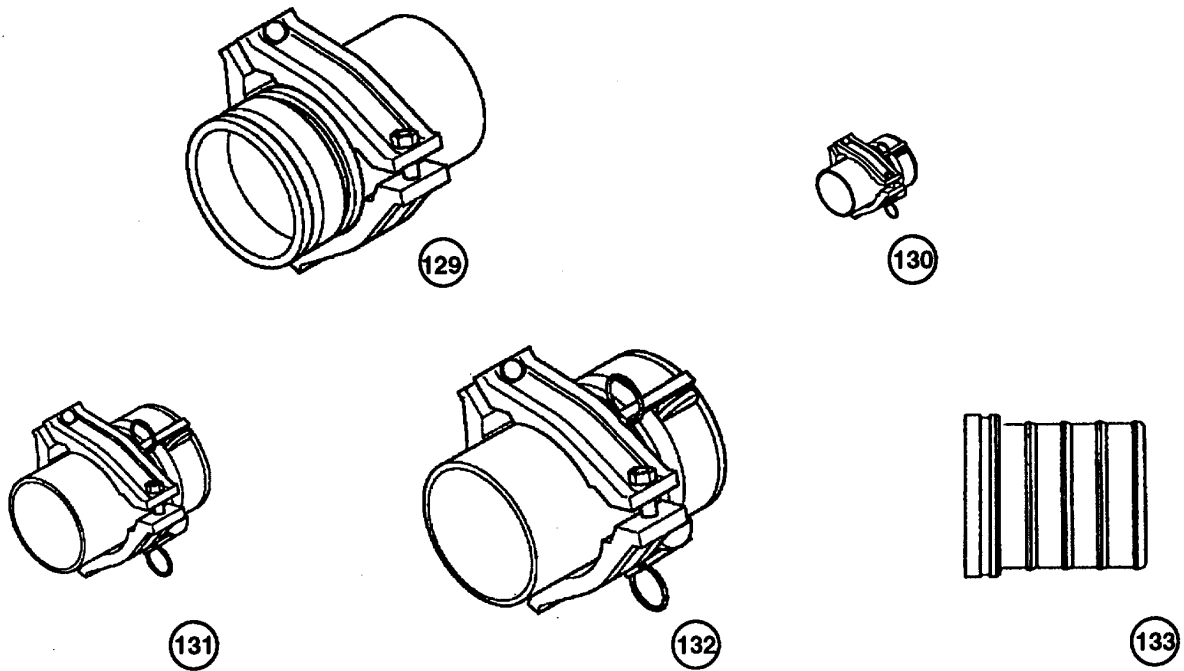
(1) ILLUS NUMBER	(2) NATIONAL STOCK NUMBER	(3) DESCRIPTION CAGEC and Part Number	Usable On Code	(4) U/M (5) Qty Rqd
120	4730-01-333-1899	SADDLE, 6 INCH (97403) 13226E1570	EA	300
121		SHACKLE, ½ INCH (81349) RR-C-271, TYPE IV, CLASS 2	EA	300
122		THIMBLE, WIRE ROPE, ½ INCH (81349) FF-T-276, TYPE II	EA	20
123		TURNBUCKLE, ½ INCH X 12 INCHES (81349) FF-T-791, TYPE 1, FORM 1, CLASS 5	EA	20

SECTION II. COMPONENTS OF END ITEM (CONTINUED)



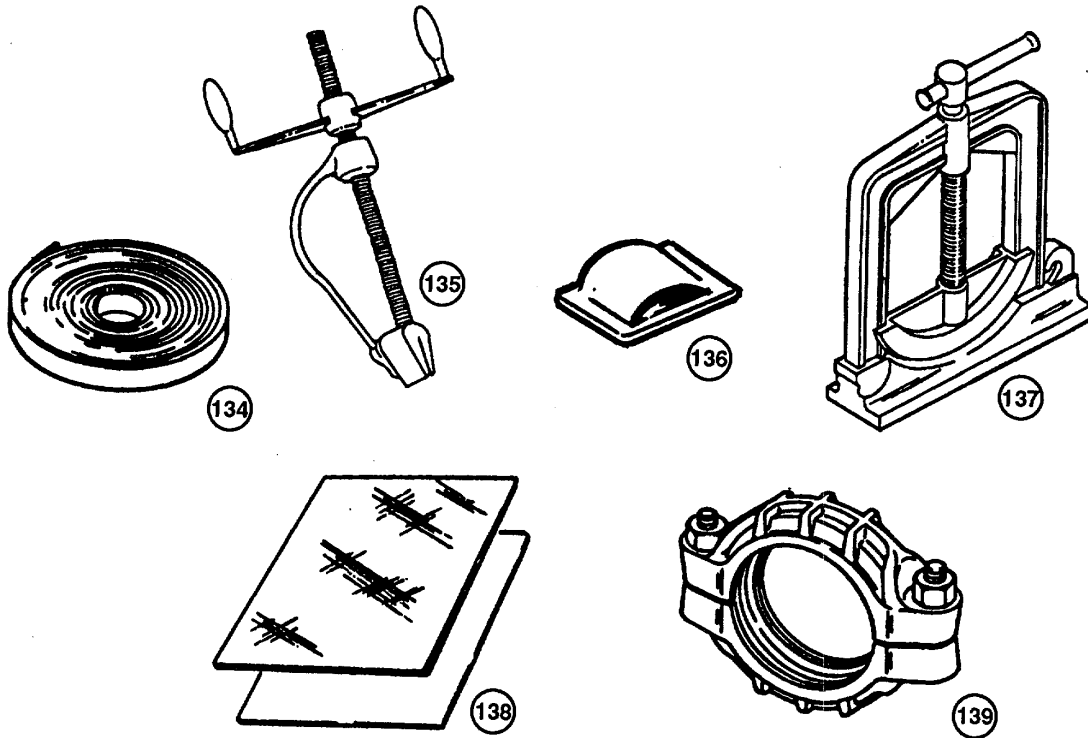
(1) ILLUS NUMBER	(2) NATIONAL STOCK NUMBER	(3) DESCRIPTION CAGEC and Part Number	Usable On Code	(4) U/M	(5) Qty Rqd
124	4730-01-199-4016	REPAIR KIT, HOSELINE, 6 IN. (97403) 13226E1581		EA	1
125		HOSE ADAPTER ASSEMBLY, GROOVED END, 6 IN. (79154) C060480AE0		EA	30
126		HOSE MENDER ASSEMBLY, GROOVED END, 6 IN. (74154) C060482AE0		EA	6
127		ADAPTER ASSEMBLY, HOSE, MALE, 2 IN. (79154) C020483AE0		EA	2
128		ADAPTER ASSEMBLY, HOSE, MALE, 4 IN. (79154) C040483AE0		EA	2

SECTION II. COMPONENTS OF END ITEM



(1) ILLUS NUMBER	(2) NATIONAL STOCK NUMBER	(3) DESCRIPTION CAGEC and Part Number	Usable On Code	(4) U/M	(5) Qty Rqd
129		ADAPTER ASSEMBLY, HOSE, MALE, 6 IN. (79154) C060483AE0		EA	2
130		ADAPTER ASSEMBLY, HOSE, FEMALE, 2 IN. (79154) C020484AE0		EA	2
131		ADAPTER ASSEMBLY, HOSE, FEMALE, 4 IN. (79154) C040484AE0		EA	2
132		ADAPTER ASSEMBLY, HOSE, FEMALE, 6 IN. (79154) C060484AE0		EA	2
133		ADAPTER, GROOVED PIPE, 6 IN. (81349) M10387ADII		EA	6

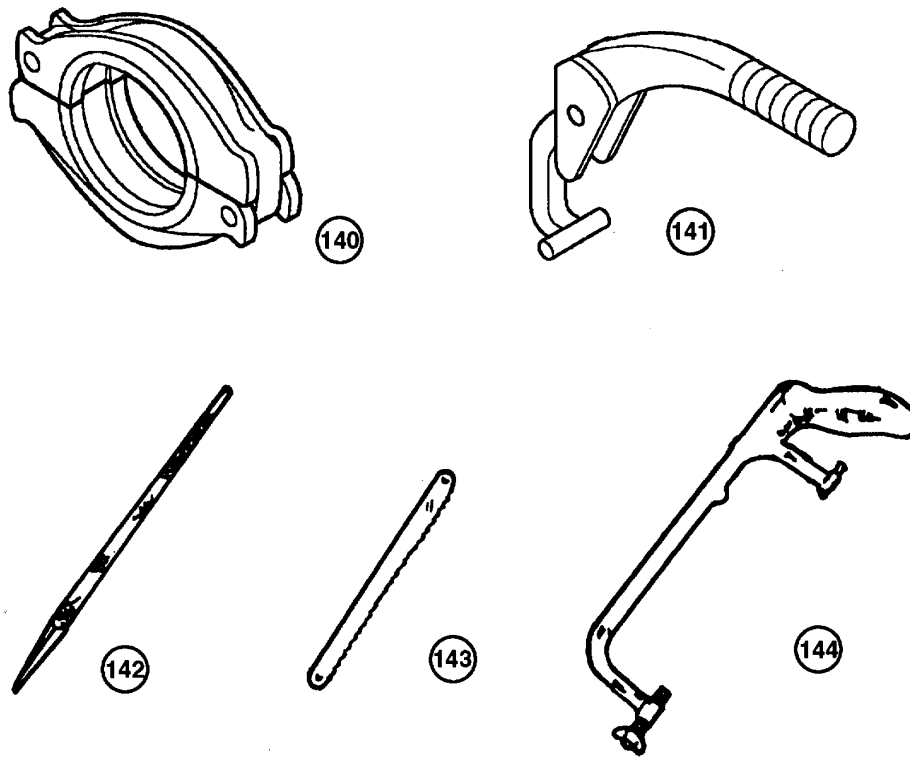
SECTION II. COMPONENTS OF END ITEM (CONTINUED)



(1) ILLUS NUMBER	(2) NATIONAL STOCK NUMBER	(3) DESCRIPTION CAGEC and Part Number	Usable On Code	(4) U/M	(5) Qty Rqd
135	3540-01-101-1625	SEALER, STEEL STRAP (70847) C001		EA	1
136		BUCKLE, BANDING, 3/4 IN.		EA	100
137	4730-01-359-7166	CLAMP, HOSE 6 IN.		EA	2
138	5350-00-584-4654	CLOTH, ABRASIVE (06565) EMERYCLOSEKOTE		EA	3
139	4730-01-176-5772	COUPLING, CLAMP, 6 INCH (81349) M10387-1-D-11		EA	*

*See note 7 at end of Components of End Item table.

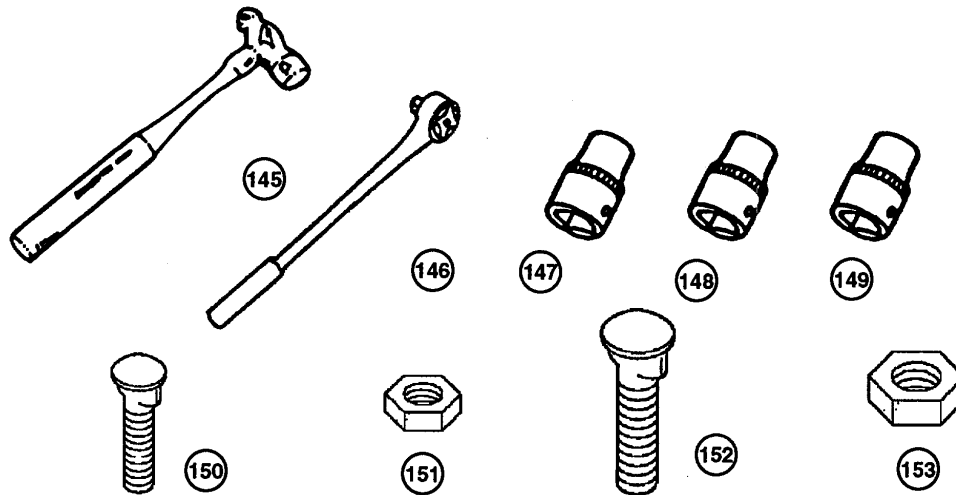
SECTION II. COMPONENTS OF END ITEM



(1) ILLUS NUMBER	(2) NATIONAL STOCK NUMBER	(3) DESCRIPTION CAGEC and Part Number	Usable On Code	(4) U/M	(5) Qty Rqd
140	4730-01-270-6555	COUPLING, CLAMP, 6 INCH (79154) 6-791-A		EA	*
141	5120-01-270-7428	WRENCH, SPANNER (79154) 792		EA	*
142		FILE, ½ ROUND, 8 INCH (43786) 00136		EA	1
143		HACKSAW BLADE, 10 INCH (78735) 00-106		EA	10
144		HACKSAW FRAME, ADJUSTABLE (03914) 70-865		EA	1

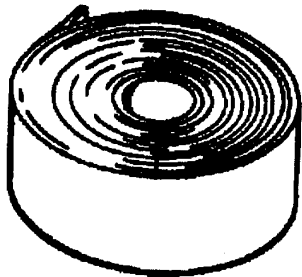
*See note 7 at end of Components of End Item table.

SECTION II. COMPONENTS OF END ITEM (CONTINUED)

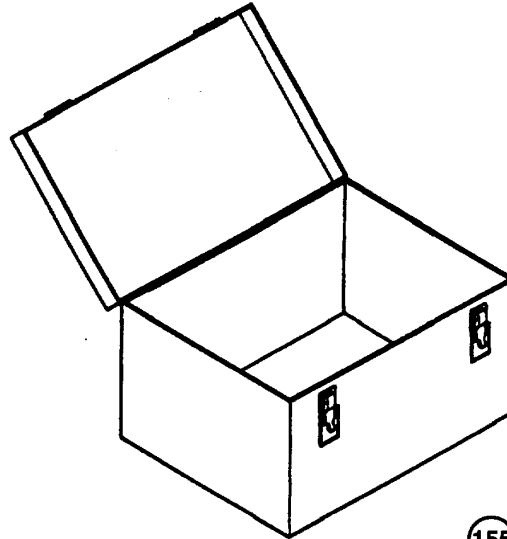


(1) ILLUS NUMBER	(2) NATIONAL STOCK NUMBER	(3) DESCRIPTION CAGEC and Part Number	(4) Usable U/M On Code	(5) Qty Rqd
145		HAMMER, BALL-PEEN, 6 INCH (39428) 5855A15	EA	1
146	5120-00-287-4152	HANDLE, SOCKET WRENCH 3/4 INCH DRIVE (39485) 547A51	EA	1
147		WRENCH, SOCKET, 3/4 DRIVE, 12 POINT, 1.25 OPENING (81348) GGG-W-641, TY II, CL 2, STY A	EA	1
148		WRENCH, SOCKET, 9/16, 12 POINT, 3/4 DRIVE (81348) GGG-W-641, TY II, CL 2, STY A	EA	5
149		WRENCH, SOCKET, 11/16, 12 POINT, 3/4 DRIVE (81348) GGG-W-641, TY II, CL 2, STY A	EA	5
150		BOLT, TRACK HEAD, 9/16 INCH (81346) ASTM A-449	EA	5
151		NUT, HEX, 9/16 INCH (81346) ASTM A-1449	EA	5
152		BOLT, TRACK HEAD, 11/16 (81346) ASTM A-449	EA	20
153		NUT, HEX, 11/16 (81346) ASTM A-449	EA	20

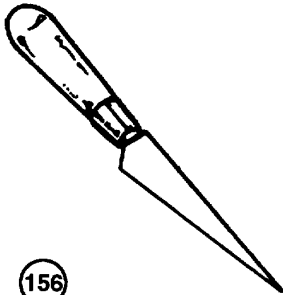
SECTION II. COMPONENTS OF END ITEM



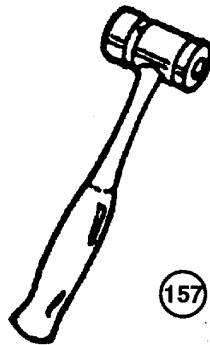
154



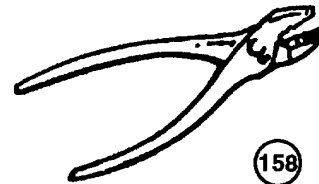
155



156



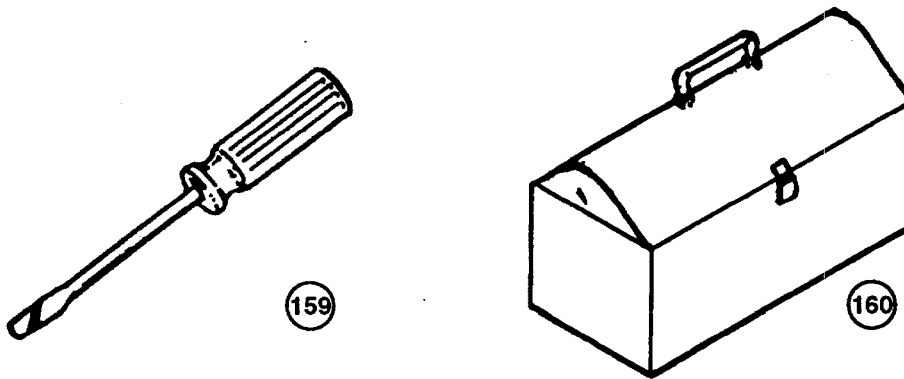
157



158

(1) ILLUS NUMBER	(2) NATIONAL STOCK NUMBER	(3) DESCRIPTION CAGEC and Part Number	Usable On Code	(4) U/M	(5) Qty Rqd
154		HOSE, RUBBER, 6 INCH X 15 FEET (19099) 53027-15AR		EA	2
155		KIT, CHEST, METAL (63317) 100-04-011		EA	1
156		KNIFE, RUBBER CUTTING, 8 X 1 INCH (29891) 60870		EA	1
157		MALLET, RUBBER, 32 OUNCE (03914) 69-490		EA	1
158		PLIERS, LINESMANS (81348) GGG-P-00471D-1		EA	1

SECTION II. COMPONENTS OF END ITEM (CONTINUED)

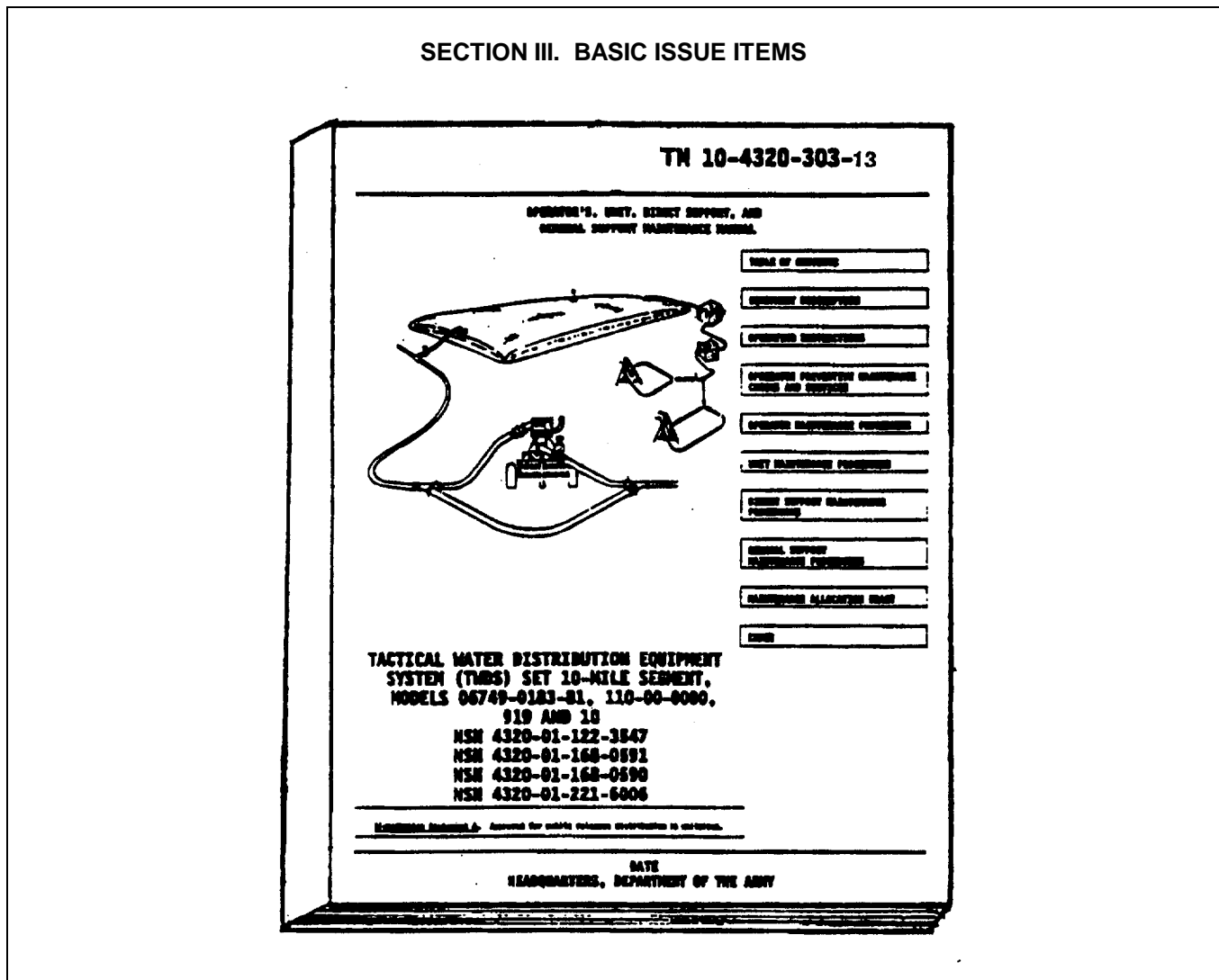


(1) ILLUS NUMBER	(2) NATIONAL STOCK NUMBER	(3) DESCRIPTION CAGEC and Part Number	Usable On Code	(4) U/M	(5) Qty Rqd
159		SCREWDRIVER, 6-½ INCH (63317) 100-10-003		EA	1
160	5140-01-248-2692	TOOL BOX, METAL (75206,) K-20/20		EA	1

NOTES

1. TWDS pumping stations may contain eight (8) 6 inch pipe coupling clamps, item 1, or eight (8) 6 inch coupling clamps, item 2. If pumping station contains item 2, it will also contain one (1) spanner wrench, item 3.
2. TWDS storage assemblies may contain one (1) 4 inch pipe coupling clamp, item 15, or one (1) 4 inch coupling clamp, item 16. If storage assembly contains item 16, it will also contain one (1) spanner wrench, item 17.
3. TWDS storage assemblies may contain one (1) 6 inch pipe coupling clamp, item 18, or one (1) 6 inch coupling clamp, item 19. If storage assembly contains item 19, it will also contain one (1) spanner wrench, item 17.
4. TWDS 10-mile hoseline segment may contain either 128 2-Way Flaking Boxes, item 66 or 54 Flaking Box Assemblies, item 67.
5. TWDS 10-mile hoseline segment may contain fifteen (15) 6 inch pipe coupling clamps, item 68, or fifteen (15) 6 inch coupling clamps, item 69. If 10-mile hoseline item 69, it will also contain one (1) spanner wrench, item 70.
6. TWDS displacement and evacuation kit may contain eight (8) 6 inch pipe coupling clamps, item 99, or eight (8) 6 inch coupling clamps, item 100. If displacement and evacuation kit contains item 100, it will also contain one (1) spanner wrench, item 101.

7. TWDS hoseline repair kit may contain three (3) 6 inch pipe coupling clamps, item 137, or three (3) 6 inch coupling clamps, item 138. If hoseline repair kit contains item 138, it will also contain one (1) spanner wrench, item 139.



(1) Illus Number	(2) National Stock Number	(3) Description CAGEC and Part Number	(4) Usable On Code U/M	(5) Qty Rqd
1		MANUAL, OPERATOR'S, UNIT, DIRECT SUPPORT, AND GENERAL SUPPORT MAINTENANCE MANUAL FOR TACTICAL WATER DISTRIBUTION EQUIPMENT SYSTEM (TWDS) SET 10-MILE SEGMENT, MODELS 06749-0183-81, 110-00-0000, 919, AND 10, TM 10-4320-303-13	EA	8

**APPENDIX D
ADDITIONAL AUTHORIZATION LIST**

SECTION I. INTRODUCTION

D.1 SCOPE.

This appendix lists additional items you are authorized for the support of the TWDS.

D.2 GENERAL.

This list identifies items that do not have to accompany the TWDS and that do not have to be turned in with it. These items are all authorized to you by CTA, MTOE, TDA, or JTA.

D.3 EXPLANATION OF LISTING.

National stock numbers, descriptions, and quantities are provided to help you identify and request the additional items you require to support this equipment. If item required differs for different models of this equipment, see the "Used On Code" for the applicable model or models. Codes used are:

<u>Code</u>	<u>Used On</u>
DTC	Model 06749-0183-81
DTQ	Model 110-00-0000
DTR	Model 919
EAM	Model 10

SECTION II. ADDITIONAL AUTHORIZED ITEMS LIST			
(1)	(2)	(3)	(4)
National Stock Number	Description CAGEC & Part Number	Usable On Code	Qty Auth
4310-01-158-3262	Compressor, Rotary, Air, DED, 250 cfm, 100 psi, Trailer Mounted, (33968) P/N P250W-D-M-H268	EA	1

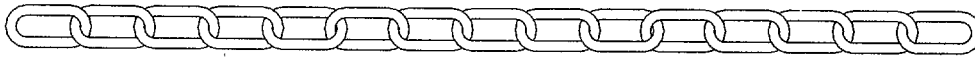


Figure F-2. Weldless Chain.

MATERIALS			
ITEM NO.	DESCRIPTION, CAGEC, AND PART NUMBER	QTY	NSN
1	Chain, Weldless (81384) RR-C-271	AR	

PROCEDURES:

1. Cut chain (1) to length such that legs of tripod assembly will separate between 34 and 35 inches when the tripod is deployed.

F-3/(F-4 Blank)

**APPENDIX E
EXPENDABLE AND DURABLE ITEMS LIST**

SECTION I. INTRODUCTION

E.1 SCOPE

This appendix lists expendable and durable items that you will need to maintain the TWDS. This listing is for informational purposes only and is not authority to requisition the listed items. These items are authorized to you by CTA 50-790, expendable items (except medical, class V repair parts, and Heraldic Items).

E.2 EXPLANATION OF COLUMNS

E.2.1 Column (1) - Item Number. This number is assigned to the entry in the listing referencing when required.

E.2.2 Column (2) - Level. This column identifies the lowest level of maintenance that requires the listed item.

C	- Operator/Crew
O	- Unit Maintenance
F	- Direct Support Maintenance
H	- General Support Maintenance

E.2.3 Column (3) - National Stock Number. This is the national stock number assigned the item; use it to request or requisition the item.

E.2.4 Column (4) - Description. Indicates the federal item name and, if required, a description to identify the item. The last line for each item indicates the Commercial and Government Entity Code (CAGEC) parentheses followed by the part number.

E.2.5 Column (5) - Unit of Measure (UM)/Unit of Issue (UI). This measure is expressed by a two character alphabetical abbreviation (eg., EA, IN, PR). If the unit of measure differs from the unit of issue as shown in the Army Master Data File (AMDF) requisition the lowest unit of issue that will satisfy your requirements.

SECTION II. EXPENDABLE AND DURABLE ITEMS LIST				
(1) Item Number	(2) Level	(3) National Stock Number	(4) Description	(5) (U/M)/ (U/I)
1	C	8415-01-333-4158	APRON, CHEMICAL (63531) 96-074	PG
2	C	6810-00-255-0472	CALCIUM HYPOCHLORITE POWDER (81348) O-C-114	DR
3	C	6550-01-285-0796	CHLORINE TEST, REAGENT (4E712)R-OOOC 1C	BT
4	C	8415-01-112-1885	GLOVES, CHEMICAL (79371) 36-124	EA
5	C		LUBRICANT, GASKET, POTABLE WATER SYSTEM (19853) 13225E9192	CN
6	C	6810-00-664-1622	pH INDICATOR SOLUTION (81349) MIL-T-17412	OZ
7	C	7920-00-205-1711	RAGS, WIPING (58536) A-A-2522	BE
8	O	6850-00-664-5685	SOLVENT, DRYCLEANING, TYPE I (58536)	QT
9	C	8030-00-889-3535	TAPE, ANTISEIZING (81349)	EA (SPOOL)

**APPENDIX F
ILLUSTRATED LIST OF MANUFACTURED ITEMS**

F.1 INTRODUCTION.

This appendix includes complete instructions for making items authorized to be manufactured or fabricated at unit maintenance level and direct support maintenance level.

A part number index in alphanumeric order is provided for cross-referencing the part number of the item to be manufactured to the figure which covers fabrication criteria.

All bulk materials needed for manufacture of an item are listed by part number or specification number in a tabular list on the illustration.

F.2 MANUFACTURED ITEMS PART NUMBER INDEX.

<u>Part Number of Manufactured Item</u>	<u>Applicable Figure</u>
100-56-001	F-1
RR-C-271	F-2

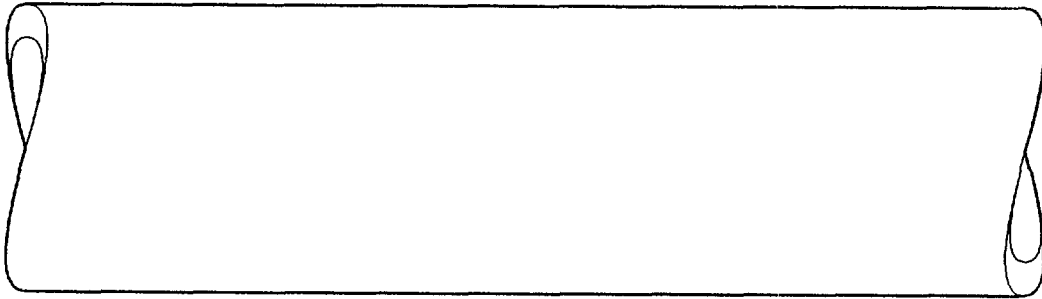


Figure F-1. Hose Material.

MATERIALS			
ITEM NO.	DESCRIPTION, CAGEC, AND PART NUMBER	QTY	NSN
1	Hose, Rubber (19099) 100-56-001	AR	

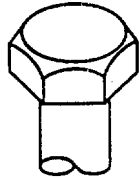
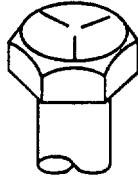


PROCEDURES:

NOTE

Always mark, score, and cut hose squarely. Do not leave ragged or uneven edges.

1. Cut hose (1), (2), or (3) to length of 10, 20, or 75 feet as required.
2. Refer to paragraph 3.4.1 and assemble hose assembly.

**APPENDIX G
TORQUE LIMITS**

SAE Grade Number	1 or 2	5	6 or 7	8
Quality of Material	Indeterminate	Minimum Commercial	Medium Commercial	Best Commercial
Capscrew Head Markings				

NOTE

Head marking may vary with different manufacturers.

Capscrew Body Size (Inches)-(Thread)		Torque Ft Lb (N•m)		Torque Ft Lb (N•m)		Torque Ft Lb (N•m)		Torque Ft Lb (N•m)	
1/4	20	5	(7)	8	(11)	10	(14)	12	(16)
	28	6	(8)	10	(14)			14	(19)
5/16	18	11	(15)	17	(23)	19	(26)	24	(33)
	24	13	(18)	19	(26)			27	(37)
3/8	16	18	(24)	31	(42)	34	(46)	44	(60)
	24	20	(27)	35	(47)			49	(66)
7/16	14	28	(38)	49	(66)	55	(75)	70	(95)
	20	30	(41)	55	(75)			78	(106)
1/2	13	39	(53)	75	(102)	85	(115)	105	(142)
	20	40	(56)	85	(115)			120	(163)
9/16	12	51	(69)	110	(149)	120	(163)	155	(210)
	18	55	(75)	120	(163)			170	(231)
5/8	11	83	(113)	150	(203)	167	(226)	210	(285)
	18	95	(129)	170	(231)			240	(325)
3/4	10	105	(142)	270	(366)	280	(380)	375	(508)
	16	115	(156)	295	(400)			420	(569)
7/8	9	160	(217)	395	(536)	440	(597)	605	(820)
	14	175	(237)	435	(590)			675	(915)
1	8	235	(319)	590	(800)	660	(895)	910	(1234)
	14	250	(339)	660	(895)			990	(1342)

CAUTION

If replacement capscrews are of a higher grade than originally supplied, use torque specifications for that placement. This will prevent equipment damage due to over torquing.

NOTE

Always use the torque values listed above when specific torque values are not available.

GLOSSARY

SECTION I. ABBREVIATIONS

COMMON ABBREVIATIONS.

The common abbreviations used in this manual are in accordance with MIL-STD-12D.

SPECIAL OR UNIQUE ABBREVIATIONS.

The following is a list of abbreviations and symbols that are used in this manual but are not listed in MIL-STD-12D.

ABBREVIATION	DEFINITION
°C.....	Degrees Celsius
°F.....	Degrees Fahrenheit
cm.....	Centimeters
CPC.....	Corrosion Prevention Control
DA.....	Department of the Army
EIR.....	Equipment Improvement Recommendation
GPM.....	Gallons Per Minute
hp.....	Horsepower
JP.....	Jet Petroleum
kg.....	Kilograms
kPA.....	KiloPascal
KW.....	Kilowatts
mm.....	Millimeters
pam.....	Pamphlet
ppm.....	Parts per Million
psig.....	Pounds per Square Inch Gauge
SF.....	Standard Form
SPM.....	Strokes per Minute
TAMMS.....	The Army Maintenance Management System
TAMMS-A.....	The Army Maintenance Management System - Aviation
tdh.....	total dynamic head
TM.....	Technical Manual
TWDS.....	Tactical Water Distribution Equipment System Set 10-Mile Segment

SECTION II. DEFINITION OF UNUSUAL TERMS

UNUSUAL TERMS.

This section provides definitions for terms used in this manual which are not defined in the United States Army Dictionary (AR 310-25). The term appears on the left of the hyphen, "-". The definition for the term appears immediately to the right of the hyphen, "-".

TERM	DEFINITIONS
Hoseline Packing	- filling of hoseline with water.
Hypochlorination for purification purposes.	- injection of large concentrations of chlorine into water
Hypochlorination Unit	- a mechanical assembly used to inject large concentrations of chlorine into potable water.

INDEX

A

Abbreviations, List of 1.12

Administrative Storage 4.23

Assemblies, Pumping, Trailer
 Mounted, Equipment Data for 1.17.1

Assemblies, Storage, Operation
 of 2.5.4

Assembly and Preparation
 for Use 2.3

Assembly of 10-Mile Hoseline
 Segment 2.3.8

Assembly of Distribution
 Points 2.3.7

Assembly of Storage
 Assemblies 2.3.6

Assembly, Boost Pumping
 Station 2.3.5

Assembly, Lead Pumping
 Station 2.3.4

Assembly, Pumping, 125 GPM,
 Equipment Data for 1.17.3

Assembly, Pumping, 125 GPM,
 Maintenance, Operator 3.6

Assembly, Storage, Functional
 Description of 1.19.2

Assembly, Storage, Operator
 Maintenance 3.5

Auxiliary Equipment, Operation
 of 2.7

B

Boost Pumping Station
 Assembly 2.3.5

Boost Pumping Station,
 Operation of 2.5.3

Boost Pumping Station,
 Operator's Controls and
 Indicators for 2.1.3

Boost Pumping Stations,
 Preparation for Movement of 2.8.4

Butterfly Valve Assembly,
 6 Inch Maintenance 4.10.2

C

Calibration 1.11

Capabilities and Features 1.14.2

Characteristics 1.14.1

Checking Unpacked Equipment 4.4.3

Collapsible Hose Assembly, 6
 Inch x 500 Foot, Replacement 4.11.1

Color Comparator
 Maintenance 4.13.10

Common Tools and Equipment,
 Direct Support Maintenance 5.1

Common Tools and Equipment,
 Unit Maintenance 4.1

Configuration, Equipment 1.18

C (Continued)

Controls and Indicators,
 Operator's 2.1

Corrosion Prevention and
 Control (CPC) 1.10

Coupling, Grooved Pipe, Removal
 and Installation 2.3.2

Coupling Clamp, Grooved-End Pipe
 Quick Disconnect, Removal and
 Installation 2.3.3

D

Data, Equipment 1.17

Decals and Instruction Plates 2.6

Decontamination, Nuclear,
 Biological, and Chemical
 (NBC) 2.10

Deprocessing Unpacked
 Equipment 4.4.4

Differences Between Models 1.16

Displacement and Evacuation
 Kit Maintenance 4.15

Distribution Point, Failure
 of 2.12.4

Distribution Point
 Maintenance 4.13

Distribution Point, TWDS,
 Control and Indicators for 2.1.5

Distribution Points,
 Assembly of 2.3.7

Distribution Points, Functional
 Description of 1.19.4

Distribution Points,
 Operation of 2.5.5

Distribution Points, Preparation
 for Movement of 2.8.6

Description, Functional 1.19

Destruction of Army Materiel
 To Prevent Enemy Use 1.3

Drain Fill Hose Assembly
 Maintenance 4.13.2

E

Emergency Procedures 2.12

Equipment, Checking Unpacked 4.4.3

Equipment, Common Tools and,
 Direct Support Maintenance 5.1

Equipment, Common Tools and,
 Unit Maintenance 4.1

Equipment Characteristics,
 Capabilities, and Features 1.14

Equipment Configuration 1.18

Equipment Data 1.17

Equipment, Deprocessing
 Unpacked 4.4.4

Equipment, Preliminary Servicing
 and Adjustment of 4.6

E (Continued)

Equipment Improvement
 Recommendation (EIR)..... 1.7

F

Failure of Distribution Point..... 2.12.4
 Failure of Storage Assembly..... 2.12.3
 Features, Capabilities and..... 1.14.2
 Fill Assembly Replacement 4.13.3
 Fill Hose Assembly
 Maintenance..... 4.13
 Flaking Box Assembly
 Maintenance..... 4.11.2
 Flaking Box Assembly Repair..... 5.4.1
 Fording..... 2.11
 Frame Assembly Replacement..... 4.13.8
 Functional Description 1.19

G

Gate Valve Assembly, 4 Inch
 Maintenance..... 4.12.1
 Gear Box Maintenance..... 5.6.2
 Glossary 1.13
 Grooved-End Pipe Quick
 Disconnect Coupling Clamp
 Removal and Installation 2.3.3
 Grooved Pipe Coupling Removal
 and Installation..... 2.3.2

H

Hose Assembly, 6 Inch, Repair..... 3.4.1
 Hose Assembly Replacement..... 4.10.3
 Hose Retaining Bracket
 Maintenance..... 4.16.1
 Hoseline, 10-Mile, Preparation
 for Movement of 2.8.2
 Hoseline, 10-Mile Segment,
 Functional Description of..... 1.19.3
 Hoseline, TWDS 10-Mile Segment,
 Operator's Control and
 Indicators for..... 2.1.2
 Hoseline, 10-Mile Segment,
 Assembly of 2.3.8
 Hoseline, 10-Mile Segment,
 Operator Maintenance of..... 3.4
 Hypochlorination Unit Frame
 Assembly Repair..... 5.6.5
 Hypochlorination Unit, Model
 1955-1, Maintenance..... 5.6
 Hypochlorination Unit, Model
 1955-1 Replacement And Repair 4.13.1
 Hypochlorination Units,
 Equipment Data for 1.17.4
 Hypochlorinator Assembly
 Maintenance..... 4.13.6

I

Initial Adjustment, Checks, and
 Self Test..... 2.4

I (Continued)

Inlet Hose Assembly
 Maintenance 4.13.2
 Installation Instructions..... 4.5
 Installation, Removal and,
 Grooved Pipe Coupling..... 2.3.2
 Installation, Removal and,
 Grooved-End Pipe Quick
 Disconnect Coupling Clamp 2.3.3
 Instruction Plates, Decals
 and 2.6
 Instructions, Installation..... 4.5
 Introduction to Unit PMCS
 Table 4.8

K

Kits, TWDS Support and Supply,
 Functional Description of 1.19.5

L

Lead Pumping Station Assembly 2.3.4
 Lead Pumping Station, Operation
 of 2.5.2
 Lead Pumping Station, Operator's
 Controls and Indicators for 2.1.1
 Lead Pumping Station,
 Preparation for Movement of 2.8.3
 Leakage Definitions, PMCS..... 2.2.5
 List of Abbreviations..... 1.12
 Location, Siting and..... 4.4.1
 Location and Description of
 Major Components..... 1.15
 Lubrication 3.1
 Lubrication, TWDS..... 4.7

M

Major Components, Location and
 Description of..... 1.15
 Main Valve Assembly Repair 5.5.2
 Maintenance, 10-Mile Segment
 Equipment 4.11
 Maintenance, Butterfly Valve
 Assembly, 6 Inch 4.10.2
 Maintenance, Color
 Comparator..... 4.13.10
 Maintenance, Displacement and
 Evacuation Kit 4.15
 Maintenance, Distribution
 Point 4.13
 Maintenance, Drain Hose
 Assembly 4.13.2
 Maintenance, Fill Hose
 Assembly 4.13.2
 Maintenance, Flaking Box
 Assembly 4.11.2
 Maintenance Forms, Records
 and Reports..... 1.2
 Maintenance, Gate Valve
 Assembly, 4 Inch. 4.12.1
 Maintenance, Gear Box 5.6.2

M (Continued)

Maintenance, Hose Retaining
 Bracket..... 4.16.1
 Maintenance, Hypochlorination
 Unit, Model 1955-1,..... 5.6
 Maintenance, Hypochlorinator
 Assembly 4.13.6
 Maintenance, Inlet Hose
 Assembly 4.13.2
 Maintenance, Manifold
 Assembly 4.13.7
 Maintenance, Outlet Hose
 Assembly 4.13.2
 Maintenance, Packing Kit 4.16
 Maintenance, Pilot Valve
 Assembly 5.6.1
 Maintenance, Pressure-Reducing
 Valve Assembly, Direct Support 5.5
 Maintenance, Pressure-Reducing
 Valve Assembly, Unit 4.11.5
 Maintenance, Pressure Regulator
 Hose Assembly 4.13.2
 Maintenance, Pressure Relief
 Valve Assembly..... 4.11.6
 Maintenance, Pumping Station,
 Operator..... 3.3
 Maintenance, Reducer
 Y-Connection 4.10.1
 Maintenance, Repair Kit 4.17
 Maintenance, Sling Assembly..... 4.18
 Maintenance, Stand Assembly..... 4.13.9
 Maintenance, Storage Assembly,
 Unit 4.12
 Maintenance, Strainer Assembly..... 4.13.4
 Maintenance, Suspension Kit..... 4.14
 Maintenance, TWDS Supply
 Connection Items 4.10
 Maintenance, Water Meter 5.6.3
 Manifold Assembly Maintenance 4.13.7
 Marking 4.21
 Materiel, Service Upon Receipt 4.4
 Models, Differences Between..... 1.16
 Movement, Preparation for 2.8

N

Nomenclature Cross-Reference..... 1.6
 Nuclear, Biological,
 and Chemical (NBC)
 Decontamination..... 2.10

O

Operating Procedures..... 2.5
 Operating Procedures, TWDS
 General 2.5.1
 Operation in Unusual Weather..... 2.9
 Operation of Auxiliary Equipment 2.7

O (Continued)

Operation of Boost Pumping
 Station 2.5.3
 Operation of Distribution Points..... 2.5.5
 Operation of Lead Pumping Station..... 2.5.2
 Operation of Storage
 Assemblies 2.5.4
 Operator's Controls and
 Indicators 2.1
 Outlet Hose Assembly
 Maintenance 4.13.2

P

Packing..... 4.20
 Packing Kit Maintenance..... 4.16
 Pilot Valve Assembly
 Maintenance 5.6.1
 Points, Distribution, Assembly
 of 2.3.7
 Points, Distribution, Functional
 Description of..... 1.19.2
 Preliminary Servicing and
 Adjustment of Equipment..... 4.6
 Preparation for Movement..... 2.8
 Preparation for Movement of
 10-Mile Hoseline 2.8.2
 Preparation for Movement of
 Boost Pumping Stations..... 2.8.4
 Preparation for Movement of
 Distribution Points..... 2.8.6
 Preparation for Movement of
 Lead Pumping Station..... 2.8.3
 Preparation for Movement of
 Storage Assemblies..... 2.8.5
 Preparation for Movement of
 TWDS, Procedures for..... 2.8.1
 Preparation for Storage or
 Shipment 1.4
 Preservation Procedures..... 4.19
 Pressure Gauge Assembly
 Replacement 4.13.3
 Pressure-Reducing Control
 Repair..... 5.5.1
 Pressure-Reducing Valve
 Assembly Maintenance,
 Direct Support..... 5.5
 Pressure-Reducing Valve
 Assembly Maintenance
 Unit..... 4.11.5
 Pressure-Reducing Valve
 Assembly Replacement..... 4.11.4
 Pressure-Reducing Valve
 Assembly Skid Assembly
 Repair..... 5.5.3
 Pressure Regulating Valve Repair..... 5.6.4
 Pressure Regulator Hose
 Assembly Maintenance..... 4.13.2
 Pressure Regulator Valve
 Replacement 4.13.7

P (Continued)

Pressure Relief Valve Assembly
 Maintenance.....4.11.6
 Procedures for Preparation
 for Movement of TWDS..... 2.8.1
 Procedures, Operating..... 2.5
 Pillow Tank, 20,000 Gallon
 Equipment Data for 1.17.2
 Pull Board Assembly Repair 4.16.2
 Pumping Assemblies, Trailer
 Mounted, Equipment Data for 1.17.1
 Pumping Assembly, 125 GPM
 Equipment Data for 1.17.3
 Pumping Assembly, 125 GPM,
 Maintenance, Operator..... 3.6
 Pumping Station, Boost, Assembly.....2.3.5
 Pumping Station, Boost,
 Operator's Controls and
 Indicators for2.1.3
 Pumping Station, Boost,
 Preparation for Movement of 2.8.4
 Pumping Station, Lead Assembly.....2.3.4
 Pumping Station, Lead, Operation of.....2.5.2
 Pumping Station, Lead,
 Operator's Controls and
 Indicators for2.1.1
 Pumping Station, Lead,
 Preparation for Movement of.....2.8.3
 Pumping Station Maintenance,
 Operator.....3.3
 Pumping Station Spacing, TWDS
 Site Location and..... 2.3.1
 Pumping Stations, Functional
 Description of 1.19.1

Q

Quality Assurance (QA)..... 1.5

R

Reducer Y-Connection
 Maintenance.....4.10.1
 Removal and Installation,
 Grooved Pipe Coupling 2.3.2
 Removal and Installation,
 Grooved-End Pipe Quick
 Disconnect Coupling Clamp..... 2.3.3
 Repair, 6 Inch Hose Assembly..... 3.4.1
 Repair, Flaking Box Assembly 5.4.1
 Repair, Hypochlorination Unit
 Frame Assembly 5.6.5
 Repair Kit Maintenance 4.17
 Repair, Main Valve Assembly 5.5.2
 Repair Parts, Direct Support
 Maintenance.....5.3
 Repair Parts, Unit
 Maintenance.....4.3
 Repair, Pressure-Reducing Control..... 5.5.1

Repair, Pressure-Reducing
 Valve Assembly Skid
 Assembly..... 5.5.3
 Repair, Pressure Regulating
 Valve 5.6.4
 Repair, Pull Board Assembly..... 4.16.2
 Replacement, Collapsible Hose
 Assembly, 6 Inch x 500
 Foot..... 4.11.1
 Replacement, Fill Assembly 4.13.3
 Replacement, Frame Assembly 4.13.8
 Replacement, Hose Assembly..... 4.10.3
 Replacement, Pressure Gauge
 Assembly..... 4.13.3
 Replacement, Pressure-Reducing
 Valve Assembly 4.11.4
 Replacement, Pressure Regulator
 Valve 4.13.7
 Replacement, Swivel Joint..... 4.11.3
 Replacement, Water Meter and
 Gear Box Assembly..... 4.13.5
 Replacement And Repair,
 Hypochlorination Unit, Model
 1955-1 4.13.1

S

Safety, Care, and :Handling..... 1.9
 Scope 1.1
 Segment, Hoseline, 10-Mile,
 Functional Description of 1.19.3
 Segment, Hoseline, 10-Mile,
 Operator Maintenance of 3.4
 Service Upon Receipt of
 Materiel..... 4.4
 Siting and Location..... 4.4.1
 Sling Assembly Maintenance 4.18
 Special Instructions,
 Operator PMCS 2.2.4
 Special Instructions,
 Unit PMCS..... 4.8.2
 Special Tools and Support
 Equipment, Direct Support
 Maintenance 5.2
 Special Tools, TIDE, and
 Support Equipment, Unit Maintenance.. 4.2
 Stand Assembly Maintenance..... 4.13.9
 Stations, Pumping, Functional
 Description of..... 1.19.1
 Storage 4.22
 Storage, Administrative 4.23
 Storage Assemblies, Assembly of..... 2.3.6
 Storage Assemblies, Operation of..... 2.5.4
 Storage Assemblies, Preparation
 for Movement of 2.8.5
 Storage Assembly, :Failure of 2.12.3
 Storage Assembly, :Functional
 Description of..... 1.19.2
 Storage Assembly Maintenance,
 Operator 3.5
 Storage Assembly Maintenance, Unit... 4.12

S (Continued)

Storage Assembly, TWDS,
 Controls and Indicators for 2.1.4
 Storage or Shipment,
 Preparation for 1.4
 Strainer Assembly Maintenance 4.13.4
 Suspension Kit Maintenance..... 4.14
 Swivel Joint Replacement..... 4.11.3

T

10-Mike Segment Equipment,
 Direct Support Maintenance..... 5.4
 10-Mile Segment Equipment
 Maintenance, Unit 4.11
 Tank, Pillow, 20,000 Gallon
 Equipment Data for..... 1.17.2
 Trailer Mounted Pumping
 Assemblies, Equipment
 Data for 1.17.1
 Troubleshooting, Operator 3.2
 Troubleshooting, Unit 4.9
 TWDS Distribution Point
 Controls and Indicators for 2.1.5
 TWDS General Operating
 Procedures..... 2.5.1
 TWDS Lubrication 4.7
 TWDS, Preparation for Movement,
 Procedures for..... 2.8.1
 TWDS Site Location and Pumping
 Station Spacing 2.3.1
 TWDS Storage Assembly, Controls
 and Indicators for..... 2.1.4
 TWDS Supply Connection Items
 Maintenance 4.10
 TWDS Support and Supply Kits,
 Functional Description of 1.19.5
 TWDS 10-Mile Hoseline Segment,
 Operator's Control and
 Indicators for..... 2.1.2

U

Unit PMCS Table, Introduction
 to..... 4.8
 Unpacking 4.4.2
 Unusual Weather, Operation in 2.9
 Use, Assembly and Preparation
 for 2.3

W

Warranty Information 1.8
 Water Meter Maintenance 5.6.3
 Water Meter and Gear Box
 Assembly Replacement..... 4.13.5

By Order of the Secretary of the Army:

Official:

MILTON H. HAMILTON
Administrative Assistant to the
Secretary of the Army
04680

GORDON R. SULLIVAN
General, United States Army
Chief of Staff

DISTRIBUTION:

To be distributed in accordance with DA FORM 12-25-E, block no. 6077, requirements for TM 10-4320-303-13.

These are the instructions for sending an electronic 2028

The following format must be used if submitting an electronic 2028. The subject line must be exactly the same and all fields must be included; however only the following fields are mandatory: 1, 3, 4, 5, 6, 7, 8, 9, 10, 13, 15, 16, 17, and 27.

From: "Whomever" <whomever@avma27.army. mil>
To: mpmtYoavma28@st-louis-emh7.army.mil

Subject: DA Form 2028

1. **From:** Joe Smith
2. **Unit:** home
3. **Address:** 4300 Park
4. **City:** Hometown
5. **St:** MO
6. **Zip:** 77777
7. **Date Sent:** 19-OCT-93
8. **Pub no:** 55-2840-229-23
9. **Pub Title:** TM
10. **Publication Date:** 04-JUL-85
11. **Change Number:** 7
12. **Submitter Rank:** MSG
13. **Submitter FName:** Joe
14. **Submitter MName:** T
15. **Submitter LName:** Smith
16. **Submitter Phone:** 123-123-1234
17. **Problem:** 1
18. **Page:** 2
19. **Paragraph:** 3
20. **Line:** 4
21. **NSN:** 5
22. **Reference:** 6
23. **Figure:** 7
24. **Table:** 8
25. **Item:** 9
26. **Total:** 123
27. **Text:**

This is the text for the problem below line 27.

RECOMMENDED CHANGES TO EQUIPMENT TECHNICAL PUBLICATIONS



THEN...JOT DOWN THE
DOPE ABOUT IT ON THIS FORM.
CAREFULLY TEAR IT OUT, FOLD IT
AND DROP IT IN THE MAIL.

SOMETHING WRONG WITH PUBLICATION

FROM: (PRINT YOUR UNIT'S COMPLETE ADDRESS)

DATE SENT

PUBLICATION NUMBER

PUBLICATION DATE

PUBLICATION TITLE

BE EXACT PIN-POINT WHERE IT IS

PAGE
NO.

PARA-
GRAPH

FIGURE
NO.

TABLE
NO.

IN THIS SPACE, TELL WHAT IS WRONG
AND WHAT SHOULD BE DONE ABOUT IT.

TEAR ALONG PERFORATED LINE

PRINTED NAME, GRADE OR TITLE AND TELEPHONE NUMBER

SIGN HERE

The Metric System and Equivalents

Linear Measure

1 centimeter = 10 millimeters = .39 inch
 1 decimeter = 10 centimeters = 3.94 inches
 1 meter = 10 decimeters = 39.37 inches
 1 dekameter = 10 meters = 32.8 feet
 1 hectometer = 10 dekameters = 328.08 feet
 1 kilometer = 10 hectometers = 3,280.8 feet

Weights

1 centigram = 10 milligrams = .15 grain
 1 decigram = 10 centigrams = 1.54 grains
 1 gram = 10 decigrams = .035 ounce
 1 dekagram = 10 grams = .35 ounce
 1 hectogram = 10 dekagrams = 3.52 ounces
 1 kilogram = 10 hectograms = 2.2 pounds
 1 quintal = 100 kilograms = 220.46 pounds
 1 metric ton = 10 quintals = 1.1 short tons

Liquid Measure

1 centiliter = 10 milliliters = .34 fl. ounce
 1 deciliter = 10 centiliters = 3.38 fl. ounces
 1 liter = 10 deciliters = 33.81 fl. ounces
 1 dekaliter = 10 liters = 2.64 gallons
 1 hectoliter = 10 dekaliters = 26.42 gallons
 1 kiloliter = 10 hectoliters = 264.18 gallons

Square Measure

1 sq. centimeter = 100 sq. millimeters = .155 sq. inch
 1 sq. decimeter = 100 sq. centimeters = 15.5 sq. inches
 1 sq. meter (centare) = 100 sq. decimeters = 10.76 sq. feet
 1 sq. dekameter (are) = 100 sq. meters = 1,076.4 sq. feet
 1 sq. hectometer (hectare) = 100 sq. dekameters = 2.47 acres
 1 sq. kilometer = 100 sq. hectometers = .386 sq. mile

Cubic Measure

1 cu. centimeter = 1000 cu. millimeters = .06 cu. inch
 1 cu. decimeter = 1000 cu. centimeters = 61.02 cu. inches
 1 cu. meter = 1000 cu. decimeters = 35.31 cu. feet

Approximate Conversion Factors

To change	To	Multiply by	To change	To	Multiply by
inches	centimeters	2.540	ounce-inches	newton-meters	.007062
feet	meters	.305	centimeters	inches	.394
yards	meters	.914	meters	feet	3.280
miles	kilometers	1.609	meters	yards	1.094
square inches	square centimeters	6.451	kilometers	miles	.621
square feet	square meters	.093	square centimeters	square inches	.155
square yards	square meters	.836	square meters	square feet	10.764
square miles	square kilometers	2.590	square meters	square yards	1.196
acres	square hectometers	.405	square kilometers	square miles	.386
cubic feet	cubic meters	.028	square hectometers	acres	2.471
cubic yards	cubic meters	.765	cubic meters	cubic feet	35.315
fluid ounces	milliliters	29.573	cubic meters	cubic yards	1.308
pints	liters	.473	milliliters	fluid ounces	.034
quarts	liters	.946	liters	pints	2.113
gallons	liters	3.785	liters	quarts	1.057
ounces	grams	28.349	liters	gallons	.264
pounds	kilograms	.454	grams	ounces	.035
short tons	metric tons	.907	kilograms	pounds	2.205
pound-foot	newton-meters	1.356	metric tons	short tons	1.102
pound-inches	newton-meters	.11296			

Temperature (Exact)

°F	Fahrenheit temperature	5/9 (after subtracting 32)	Celsius temperature	°C
----	------------------------	----------------------------	---------------------	----

This fine document...

Was brought to you by me:



[Liberated Manuals -- free army and government manuals](#)

Why do I do it? I am tired of sleazy CD-ROM sellers, who take publicly available information, slap “watermarks” and other junk on it, and sell it. Those masters of search engine manipulation make sure that their sites that sell free information, come up first in search engines. They did not create it... They did not even scan it... Why should they get your money? Why are not letting you give those free manuals to your friends?

I am setting this document FREE. This document was made by the US Government and is NOT protected by Copyright. Feel free to share, republish, sell and so on.

I am not asking you for donations, fees or handouts. If you can, please provide a link to liberatedmanuals.com, so that free manuals come up first in search engines:

<A HREF=<http://www.liberatedmanuals.com/>>Free Military and Government Manuals

– Sincerely
Igor Chudov
<http://igor.chudov.com/>