



# **AMD FirePro™ W9000 Graphics Accelerator**

User Guide

© 2012 Advanced Micro Devices Inc. All rights reserved.

The contents of this document are provided in connection with Advanced Micro Devices, Inc. ("AMD") products. AMD makes no representations or warranties with respect to the accuracy or completeness of the contents of this publication and reserves the right to discontinue or make changes to products, specifications, product descriptions or documentation at any time without notice. The information contained herein may be of a preliminary or advance nature. No license, whether express, implied, arising by estoppel or otherwise, to any intellectual property rights is granted by this publication. Except as set forth in AMD's Standard Terms and Conditions of Sale, AMD assumes no liability whatsoever, and disclaims any express or implied warranty, relating to its products including, but not limited to, the implied warranty of merchantability, fitness for a particular purpose, or infringement of any intellectual property right.

AMD's products are not designed, intended, authorized or warranted for use as components in systems intended for surgical implant into the body, or in other applications intended to support or sustain life, or in any other application in which the failure of AMD's product could create a situation where personal injury, death, or severe property or environmental damage may occur. AMD reserves the right to discontinue or make changes to its products at any time without notice.

USE OF THIS PRODUCT IN ANY MANNER THAT COMPLIES WITH THE MPEG-2 STANDARD IS EXPRESSLY PROHIBITED WITHOUT A LICENSE UNDER APPLICABLE PATENTS IN THE MPEG-2 PATENT PORTFOLIO, WHICH LICENSE IS AVAILABLE FROM MPEG LA, L.L.C., 6312 S. FIDDLERS GREEN CIRCLE, SUITE 400E, GREENWOOD VILLAGE, COLORADO 80111.

## Trademarks

AMD, the AMD Arrow logo, ATI, the ATI logo, AMD Athlon, AMD LIVE!, AMD Opteron, AMD Phenom, AMD Sempron, AMD Turion, AMD64, All-in-Wonder, AMD Avivo, AMD Catalyst, AMD CrossFire, AMD CrossFireX, AMD FirePro, AMD FireStream, AMD HyperMemory, AMD OverDrive, AMD PowerPlay, AMD PowerXpress, AMD Radeon, Remote Wonder, SurroundView, Theater, The Ultimate Visual Experience, Vari-Bright, and combinations thereof are trademarks of Advanced Micro Devices, Inc.

HyperTransport is a licensed trademark of the HyperTransport Technology Consortium.

HDMI is a licensed trademark of HDMI Licensing, LLC.

PCI Express and PCIe are registered trademarks of PCI-SIG Corporation.

Linux is a registered trademark of Linus Torvalds.

DirectX, Microsoft, Windows, and Windows Vista are registered trademarks of the Microsoft Corporation in the United States and/or other jurisdictions.

OpenCL is a trademark of Apple Inc. used by permission by Khronos.

Other product names used in this publication are for identification purposes only and may be trademarks of their respective companies.

Dolby Laboratories, Inc.

Manufactured under license from Dolby Laboratories.

Rovi Corporation

This device is protected by U.S. patents and other intellectual property rights. The use of Rovi Corporation's copy protection technology in the device must be authorized by Rovi Corporation and is intended for home and other limited pay-per-view uses only, unless otherwise authorized in writing by Rovi Corporation.

Reverse engineering or disassembly is prohibited.

## Disclaimer

While every precaution has been taken in the preparation of this document, Advanced Micro Devices, Inc. assumes no liability with respect to the operation or use of AMD hardware, software or other products and documentation described herein, for any act or omission of AMD concerning such products or this documentation, for any interruption of service, loss or interruption of business, loss of anticipatory profits, or for punitive, incidental or consequential damages in connection with the furnishing, performance, or use of the AMD hardware, software, or other products and documentation provided herein. Ensure that you have the latest documentation.

---

## Important Safety Instructions

**Note:** This product is for use only with compatible UL-listed personal computers that have installation instructions detailing user installation of this class of product.

**Read all instructions before beginning installation.** All safety and installation instructions should be read before the product is installed or operated.

**Retain all instructions.** Safety, installation, and operating instructions should be retained for future reference.

**Heed all warnings.** All warnings regarding the product and its operating instructions should be obeyed.

**Use appropriate grounding.**

### Caution:

For continued protection against the risk of electric shock and fire, install this accessory only in products equipped with a three-wire grounding plug, a plug having a third (grounding) pin. This is a safety feature. Do not remove the grounding pin of a three-pin plug.

**Attach product securely.** All product-securing screws or fasteners should be completely tightened in order to provide continuous bonding between the product and the PC chassis, as appropriate.



# Contents

---

<b>Chapter 1 Getting Started</b> .....	<b>1</b>
1.1 System Requirements .....	1
1.1.1 Requirements for AMD CrossFire Pro Technology .....	1
1.2 Recording Serial Numbers .....	2
<b>Chapter 2 Hardware and Software Installation</b> .....	<b>3</b>
2.1 Installation Overview .....	3
2.2 Installing a PCI Express Graphics Card .....	3
2.3 Installing Graphics Drivers and Software .....	5
2.3.1 AMD Drivers and Software .....	5
2.3.2 AMD Automatic Application Detection and Configuration .....	6
<b>Chapter 3 Display Configuration</b> .....	<b>7</b>
3.1 Baseplate Connections .....	7
3.2 Connecting Displays .....	7
3.2.1 Multiple Displays .....	8
3.3 Using Adapters .....	9
<b>Chapter 4 Using the Control Center Software</b> .....	<b>11</b>
4.1 Control Center Overview .....	11
4.2 Starting the Control Center Software .....	11
<b>Chapter 5 AMD CrossFire Pro Technology</b> .....	<b>13</b>
5.1 AMD CrossFire Pro Overview .....	13
5.2 Installing AMD CrossFire Pro Graphics Cards .....	13
<b>Chapter 6 Reference</b> .....	<b>17</b>
6.1 Product Features .....	17
6.1.1 Stereoscopic Glasses .....	17
6.1.2 Synchronization .....	18
6.1.3 Hydravision .....	23
6.1.4 DisplayPort Audio .....	24
6.2 Workstation Card Troubleshooting .....	24
6.2.1 Computer does not boot up properly .....	25
6.2.2 There is no display .....	25
6.2.3 There are screen defects .....	25

---

6.2.4	The screen image is off-center or there are odd colors.....	26
6.2.5	The operating system warns that the graphics card isn't properly configured.....	26
6.2.6	There are bus address or interrupt conflicts.....	26
6.3	Workstation Customer Care.....	27
6.3.1	Contact Information.....	27
6.3.2	Disclaimer.....	27
6.4	Workstation Warranty Service.....	27
6.4.1	Shipping.....	27
6.4.2	Limitations.....	28
6.5	International Compliance Information.....	28
6.5.1	FCC Compliance Information (USA).....	29
6.5.2	Industry Canada Compliance Statement (Canada).....	30
6.5.3	CE Compliance Information (European Union).....	30
6.5.4	Electrical Safety.....	31
6.5.5	VCCI ITE Compliance Information (Japan).....	31
6.5.6	KC Certification Information (Korea).....	32
6.5.7	BSMI Certification Information (Taiwan).....	33
6.5.8	C-Tick (Australia and New Zealand).....	34
6.5.9	Product Environmental Compliance.....	34
6.5.10	Waste Electrical and Electronic Equipment (WEEE) Directive Compliance (European Union).....	34

# Chapter 1

## Getting Started

---

Before you begin installing your new AMD FirePro™ W9000 graphics card (P/N: 102-C38801-xx), please make sure you have the proper system requirements and have completed the required preinstallation tasks as outlined in this chapter.

### 1.1 System Requirements

The following are minimum requirements for installing a single AMD FirePro™ W9000 graphics accelerator:

- AMD Opteron™, AMD Phenom™, AMD Athlon™, Intel Xeon, or Intel Core™ CPU.
- Motherboard with available ×16 lane PCI Express® connection slot and correct chipset driver.
- 1 GB of system memory.
- Internet connection or CD-ROM/DVD-ROM drive for installation software.
- 550-watt or better power supply with one PCIe® AUX 8-pin and one PCIe AUX 6-pin power connector.
- Windows® 7, Windows® 8, Windows Vista®, Windows® XP, or Linux® operating system (64-bit is recommended). Windows Vista, Windows 7, or Windows 8 is recommended for full feature functionality.
- High-resolution multi-sync or multi-frequency display(s). Use of three or more displays with AMD Eyefinity technology requires DisplayPort-capable displays or AMD Eyefinity validated dongles. For more information, see [Connecting Displays](#) (p. 7).

#### 1.1.1 Requirements for AMD CrossFire™ Pro Technology

The following are requirements for installing an additional graphics accelerator for AMD CrossFire™ Pro configurations:

- AMD CrossFire certified motherboard. For more information, see [support.amd.com/us/certified/Pages/certified-components.aspx](http://support.amd.com/us/certified/Pages/certified-components.aspx).
- A second AMD FirePro™ W9000 graphics accelerator.

- One AMD CrossFire internal bridge interconnect per additional accelerator (included).
- 850-watt or better power supply with four PCIe AUX 8-pin and two PCIe AUX 6-pin power connectors.

For an up-to-date listing of certified power supplies, see [support.amd.com/us/certified/power-supplies/Pages/listing.aspx](http://support.amd.com/us/certified/power-supplies/Pages/listing.aspx).

- Certified system case with good airflow and cooling (highly recommended).

## 1.2 Recording Serial Numbers

The serial number and 102 part number on the graphics card are required for product registration and warranty (proof of purchase may be required). They are located on a sticker on the back of the graphics card and are shown in boldface and underlined in the illustration below.

Record these numbers in the space provided below and retain for future use.

1. Remove the graphics card from packing.
2. Locate the white label on the back of the graphics card.
3. Record the serial number and 102 part number.

---

Figure 1–1 Typical Serial Number and 102 Part Number Arrangement



---

1	Serial number (S/N)
2	102 part number (P/N)

---



# Chapter 2

## Hardware and Software Installation

---

This chapter details how to install your graphics accelerator in your system as well as where to download associated software and drivers.

### 2.1 Installation Overview

Once you have determined that your system meets the minimum requirements, perform the following tasks to install your new graphics accelerator. Detailed installation instructions are provided in the following sections.

1. If you are replacing an existing graphics accelerator, uninstall the old graphics driver and software.

**Note:** If you are using a motherboard containing an on-board graphics solution and do not intend to use it as part of a multiple monitor display, disable it.

2. Turn off and disconnect your computer system.
3. If needed, remove any old graphics accelerator(s).
4. Install the new graphic accelerator.
5. Reassemble and connect your computer system and display(s).
6. Start the computer system and install the AMD FirePro™ drivers and configuration software.
7. Restart the computer system.

### 2.2 Installing a PCI Express Graphics Card

Please read all installation instructions completely before you begin.

If your computer has on-board graphics, you may need to disable it through the BIOS configuration. For more information, see your motherboard documentation.

**Note:** Always handle a graphics card with care when adding or removing it from your system.

- Never twist or bend your card.
- Avoid interference from the card's fan housing with mechanical hinges or clips inside your system's chassis.
- Make sure that the PCIe® card slot-locking mechanism on the motherboard is unlocked or open before inserting or removing a card. Please consult your motherboard manual for instructions, if necessary.

1. Turn off your computer, monitor(s), and other peripheral devices.

2. Unplug the computer's power cord, and then disconnect all cables from the back of the computer.

**Caution:**

Wait approximately 20 seconds after unplugging the power cord before disconnecting a peripheral cable or removing a component from the motherboard to avoid possible damage to the motherboard.

3. Remove the cover to your computer's case.

**Note:** If necessary, consult your computer's manual for help in removing the cover.

**Caution:**

Static electricity can seriously damage computer components. Discharge your body's static electricity by touching the power supply or the metal surface of the computer chassis before you touch any components inside your computer's case to avoid damaging them.

4. Unscrew or unfasten and remove any existing graphics card from your computer, if necessary.

**Caution:**

Make sure the PCIe card slot-locking mechanism is unlocked or open before trying to remove a graphics card. Failure to do so may damage the card and/or the motherboard. This locking mechanism may be hidden from view by a card's fansink.

Figure 2-1 Example PCIe Card Slot-locking Mechanism

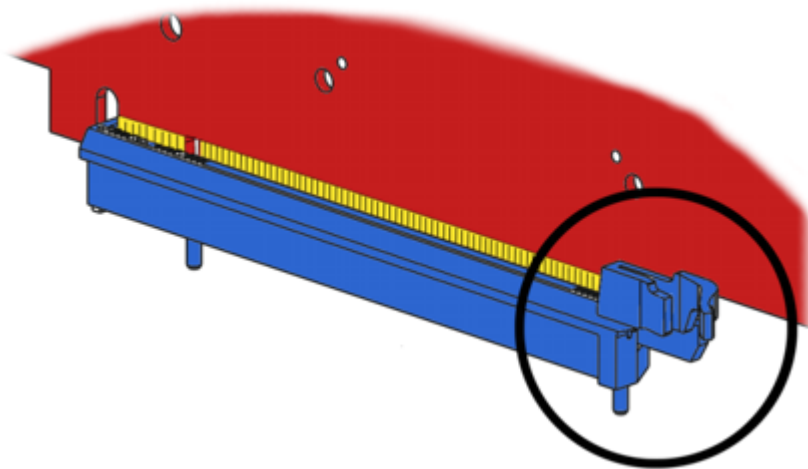

5. Locate the appropriate slot and, if necessary, remove the metal back-plate cover. Make sure all internal cables are clear of the slot.
6. Align your AMD FirePro graphics card with the PCIe slot and press it in firmly until the card is fully seated. You may need to hold open the PCIe card slot-locking mechanism with your finger when you seat the card.
7. Screw in or fasten the graphics card securely.

8. If your card requires supplementary power and must be connected directly to the power supply, locate the appropriate power connector cable (or cables) from the power supply and connect it (or them) to the graphics card's supplementary power connector(s), which are usually located in the upper corner of the card.  
**Note:** Before installing a card that requires a supplementary power connection, make sure your existing power supply has such a connection available.
9. Make sure no internal cables are interfering with components inside the computer (for example, a cooling fan) and replace the computer cover.
10. Reconnect any cables that were disconnected during installation and plug in the computer's power cord.
11. Turn on the monitor, and then your computer.

---

If you have properly installed your graphics card, operating system messages will appear and the boot procedure will proceed.

Your monitor will be running in a basic (VGA) video mode. Higher refresh rates are not available at this stage of the installation. Once you have installed the AMD FirePro drivers and software, you can use the Windows® **Display Properties** dialog to adjust your video settings and configure multiple monitors.

---

Proceed to install the software and drivers for your AMD FirePro graphics card.

## 2.3 Installing Graphics Drivers and Software

To install or remove the drivers and software, you must be logged on as a user with administrator rights.

Drivers and configuration software, which include the Control Center software application, are provided to both operate and take advantage of all the features of the graphics accelerator. For information on some the key features that are available for your product, see [Chapter 4 Using the Control Center Software \(p. 11\)](#).

### 2.3.1 AMD Drivers and Software

Drivers are small but important programs that enable an operating system to communicate with a piece of hardware, such as a graphics card.

When you install a new graphics card, you must also install the driver and configuration software the card requires to function properly.

You also need to install (or reinstall) your AMD FirePro drivers when you have reinstalled or upgraded your operating system or when you download updated drivers.

The latest drivers are available from AMD's Web site at: [support.amd.com/us/gpudownload/Pages/index.aspx](http://support.amd.com/us/gpudownload/Pages/index.aspx).

**Note:** When reinstalling drivers, always uninstall any previous drivers that are on your system, even if they are for the same graphics card. Always start "fresh."

## 2.3.2 AMD Automatic Application Detection and Configuration

AMD FirePro drivers offer automatic application detection and configuration, which enables the graphics driver to automatically detect an application when it starts and configure the graphics driver settings for optimal performance.

This detection feature works with multiple open applications. As you switch between multiple applications, the graphics settings are always automatically configured for maximum performance for the particular application currently running.

# Chapter 3

## Display Configuration

This chapter describes how to configure displays. It also lists available display connections for your graphics accelerator.

### 3.1 Baseplate Connections

The following figure shows the display connections available on your graphics accelerator.

**Note:** Baseplate may not appear exactly as depicted.

Figure 3-1 AMD FirePro™ W9000 Baseplate Connections

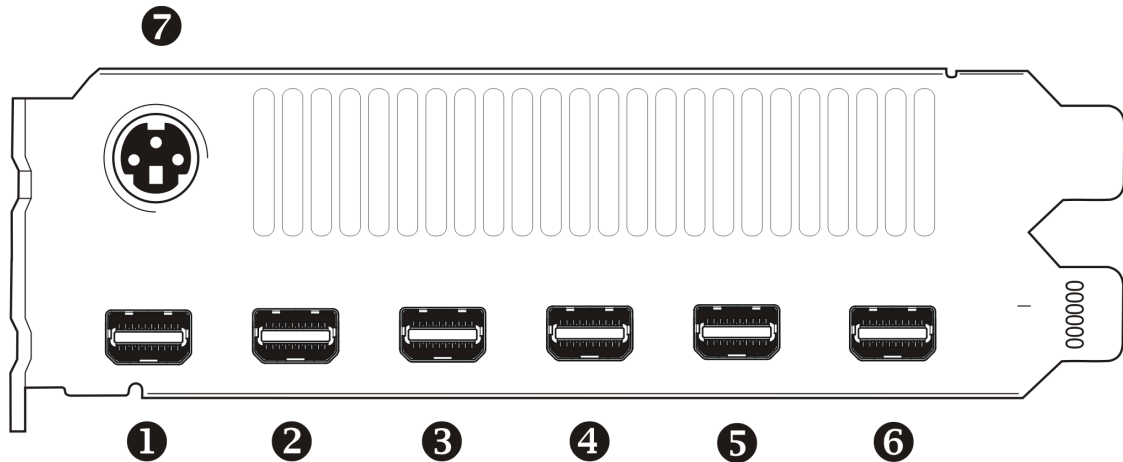

1	Mini DisplayPort 1.2 connection
2	Mini DisplayPort 1.2 connection
3	Mini DisplayPort 1.2 connection
4	Mini DisplayPort 1.2 connection
5	Mini DisplayPort 1.2 connection
6	Mini DisplayPort 1.2 connection
7	VESA 3-pin stereo sync connection for stereoscopic glasses

### 3.2 Connecting Displays

The following table lists the different ways you can connect displays to your card:

Table 3–1 Display Connection Options

Display	Connection Options
Mini DisplayPort display	Mini DisplayPort connection
DisplayPort display	Mini DisplayPort connection with Mini DisplayPort-to-DisplayPort connection
DFP (digital flat-panel) display	Mini DisplayPort connection with Mini DisplayPort-to-DVI adapter (single- or dual-link)
HDMI™ display	Mini DisplayPort connection with Mini DisplayPort-to-HDMI adapter
CRT (cathode ray tube) display	Mini DisplayPort connection with Mini DisplayPort-to-VGA adapter

**Note:** Adapters mentioned here may not be included with your AMD FirePro product.

Once displays are connected to the graphics card, you can control how they are currently configured as well as how Windows® desktops appear on the displays using the Control Center software application. Common configuration tasks include:

- Adding and removing displays
- Rotating displays
- Setting the main (primary) display
- Duplicating and extending desktops
- Arranging desktops

For more information, see [Chapter 4 Using the Control Center Software \(p. 11\)](#).

### 3.2.1 Multiple Displays

Your AMD FirePro™ W9000 graphics card provides display functionality for up to six displays through six Mini DisplayPort connections in Windows® 7, Windows® 8, Windows Vista®, or Linux®.

Your AMD FirePro™ W9000 graphics card Mini DisplayPort 1.2 connections support a maximum resolution of 4096 × 2304 pixels, and up to six displays.

Different types of displays can be combined within the following parameters:

- Your AMD FirePro™ W9000 has two clocks.
- Two displays connected with active adaptors (active single-link DVI, dual-link DVI, and VGA) can share a clock, while displays connected with passive adaptors (passive single-link DVI and HDMI) require a separate clock per device.
- Monitors connected via passive adapters must all have the same resolution and refresh rate.

The following table shows some examples of multiple display configurations; (A) indicates an active adapter is used and (P) indicates a passive adapter is used. Display abbreviations are mDP = Mini DisplayPort, DP = DisplayPort, sDVI = single-link DVI, and dDVI = dual-link DVI.

Table 3–2 Sample Display Configurations

Sample Display Configuration	mDP Connector	mDP Connector	mDP Connector	mDP Connector	mDP Connector	mDP Connector	Total Output
mDP-mDP-mDP-mDP-mDP-mDP	Native	Native	Native	Native	Native	Native	6
mDP-mDP-mDP-mDP-DP-DP	Native	Native	Native	Native	mDP to DP (P)	mDP to DP (P)	6
mDP-mDP-mDP-mDP-dDVI-dDVI	Native	Native	Native	Native	mDP to DVI (A)	mDP to DVI (A)	6
mDP-mDP-mDP-mDP-VGA-VGA	Native	Native	Native	Native	mDP to VGA (A)	mDP to VGA (A)	6
mDP-mDP-mDP-mDP-dDVI-VGA	Native	Native	Native	Native	mDP to DVI (A)	mDP to VGA (A)	6
mDP-mDP-mDP-mDP-HDMI	Native	Native	Native	Native	mDP to HDMI (P)	No connection	5
sDVI-sDVI-sDVI-sDVI-sDVI-sDVI	mDP to DVI (P)	mDP to DVI (P)	mDP to DVI (P)	mDP to DVI (P)	mDP to DVI (P)	mDP to DVI (P)	6
HDMI-HDMI	mDP to HDMI (P)	mDP to HDMI (P)	No connection	No connection	No connection	No connection	2

Adapters not included with your AMD FirePro™ W9000 can be purchased directly from AMD's Web site (<http://www.amd.com>) or through your local AMD resellers.

Active displays will supersede passive displays. For example, if you connect a DisplayPort display to a system that already has two passive single-link DVI displays, one of the single-link DVI displays will deactivate.

Additional configuration information can be found at:

<http://www.amd.com/us/products/workstation/graphics/ati-firepro-3d/Pages/ati-firepro-3d.aspx>

A list of compatible adapters/dongles for AMD FirePro products can be found at:

<http://support.amd.com/us/eyefinity/Pages/eyefinity-dongles.aspx>

**Important:** Windows® XP supports a maximum of two displays; for greater display functionality, you must use Windows 7, Windows 8, Windows Vista, or Linux.

### 3.3 Using Adapters

Your AMD FirePro product includes adapters to enable you to attach display types other than those included on the baseplate or cables.

Use the following procedure to attach a display using an adapter.

1. Turn off your computer and monitor.

2. Plug the adapter into the connection from the baseplate of your AMD FirePro product and tighten the thumbscrews (if there are any).
3. Connect your display's cable to the adapter and tighten the thumbscrews (if there are any).
4. Turn on your display first, then your computer.

Use the Control Center application to configure the new display, should you need to do so.



# Chapter 4

## Using the Control Center Software

---

### 4.1 Control Center Overview

The Control Center software application contains settings for configuring and fine-tuning your AMD product. Use it to manage desktops and displays, optimize your graphics processor for enhanced 3D application and video quality, and configure your CPU for improved power savings or system performance. You can also use the performance tools in the application to monitor and manage clock speed and memory use for your graphics card to ensure that your AMD product is configured and running as efficiently as possible.

The application provides a Standard View for guided configuration and an Advanced View for quick and easy access to all available features and settings. It also provides a search feature for finding specific pages, as well as the ability to bookmark pages by pinning them within the application.

The following is a list of common configuration tasks that can be completed using the application:

- Adding and removing displays
- Rotating displays
- Setting the main (primary) display
- Duplicating and extending desktops
- Arranging desktops
- Enabling and disabling 3D application and video settings

More information on the application and its available features are provided through the comprehensive Control Center help system.

**Note:** Feature availability varies between AMD products and operating systems.

### 4.2 Starting the Control Center Software

To start the Control Center software application in Windows®, use any of the following methods:

Table 4–1 Control Center Access Routes in Windows®

Access Route	Instructions
Windows Desktop	<ol style="list-style-type: none"> <li>1. Right-click anywhere on the desktop.</li> <li>2. From the shortcut menu that appears, click the Control Center option.</li> </ol>
Windows Start Menu	<ol style="list-style-type: none"> <li>1. Click <b>Start</b> on the Windows task bar.</li> <li>2. Click <b>All Programs</b> followed by the Control Center option.</li> </ol>
Windows Notification Area	<ol style="list-style-type: none"> <li>1. Right-click the Control Center icon in the Windows Notification Area.</li> <li>2. From the shortcut menu, click the Control Center option.</li> </ol>
Desktop Shortcut	If you chose to create a desktop shortcut to the Control Center application during the driver installation, double-click the shortcut.

To start the application in Linux®, type the command `amdcccle` in the terminal window.

To start the application with superuser privileges, do any of the following:

- Log on as a superuser before running the command `amdcccle`.
- Run the command `sudo amdcccle` and provide the superuser password when prompted.
- Run the command `amxdg-su -c amdcccle` and provide the superuser password when prompted.

**Note:** Certain Control Center settings can only be changed with superuser privileges.

# Chapter 5

## AMD CrossFire™ Pro Technology

---

**Note:** These features are only available for AMD FirePro™ W9000 graphics cards with AMD CrossFire™ Pro connections.

### 5.1 AMD CrossFire™ Pro Overview

AMD CrossFire Pro is a multi-GPU (graphics processing unit) high performance graphics platform. It enables two graphics processors installed in a single computer to work together to improve system performance.

Once your graphics cards have been installed, you can enable and configure AMD CrossFire Pro support using the Control Center software application.

### 5.2 Installing AMD CrossFire™ Pro Graphics Cards

These instructions assume that a PCIe® graphics card has already been successfully installed in the secondary slot (slot one), and that the primary slot (slot zero) is empty.

For an up-to-date listing of AMD CrossFire Pro certified motherboards and power supplies, see <http://support.amd.com/us/certified/Pages/certified-components.aspx>

1. Make sure the computer, monitor, and other peripheral devices are off.
2. Unplug the computer power cord and disconnect the monitor cable from the back panel of the computer.

**Caution:**

To avoid possible damage to the motherboard, wait approximately 20 seconds after unplugging the power cord before disconnecting a peripheral or removing a component from the motherboard.

3. Remove the computer cover.

If necessary, consult the computer manual for help removing the cover.

**Caution:**

Remember to discharge your body's static electricity by touching the power supply case or the metal surface of the computer chassis.

4. Locate the primary PCIe slot on the motherboard. If necessary, remove the corresponding back panel cover.

5. Align the new workstation card in the primary PCIe slot next to the existing graphics card and press firmly until the card is fully seated.

Figure 5-1 AMD FirePro™ Card Installation

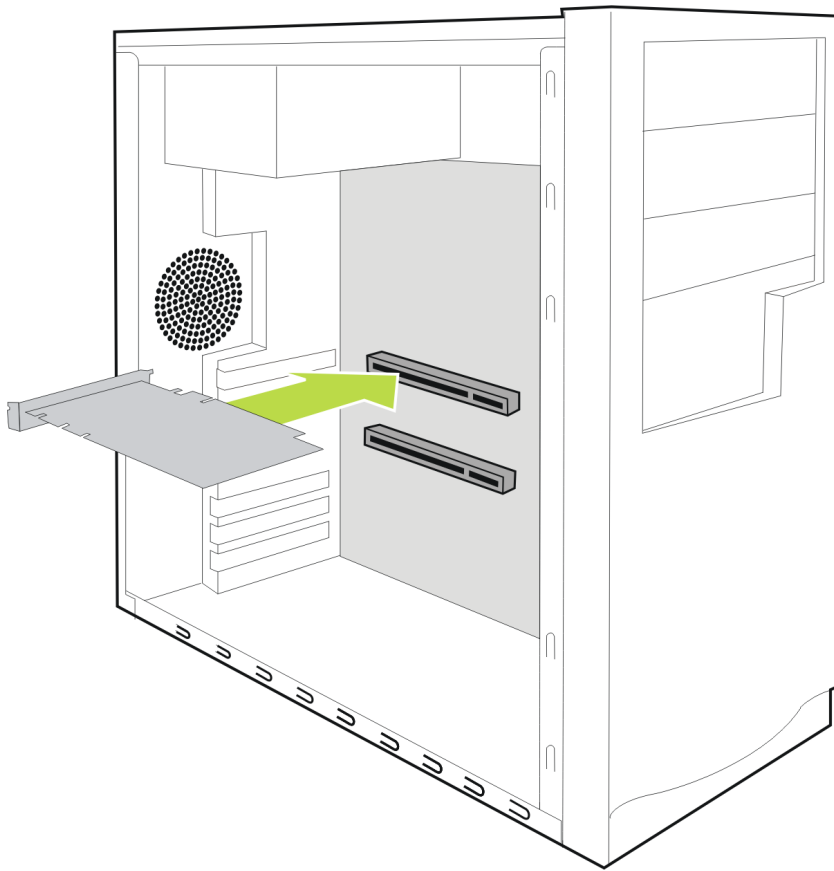

**Note:** You may need to hold open the PCIe card slot-locking mechanism with your finger when you seat the card.

6. Fasten the workstation card securely to the back panel.
7. Connect external power to the workstation card from the systems power supply, if necessary.

8. Connect the two AMD FirePro™ workstation cards using the AMD CrossFire Pro bridge interconnect.

Figure 5-2 AMD CrossFire™ Pro Interconnect Installation

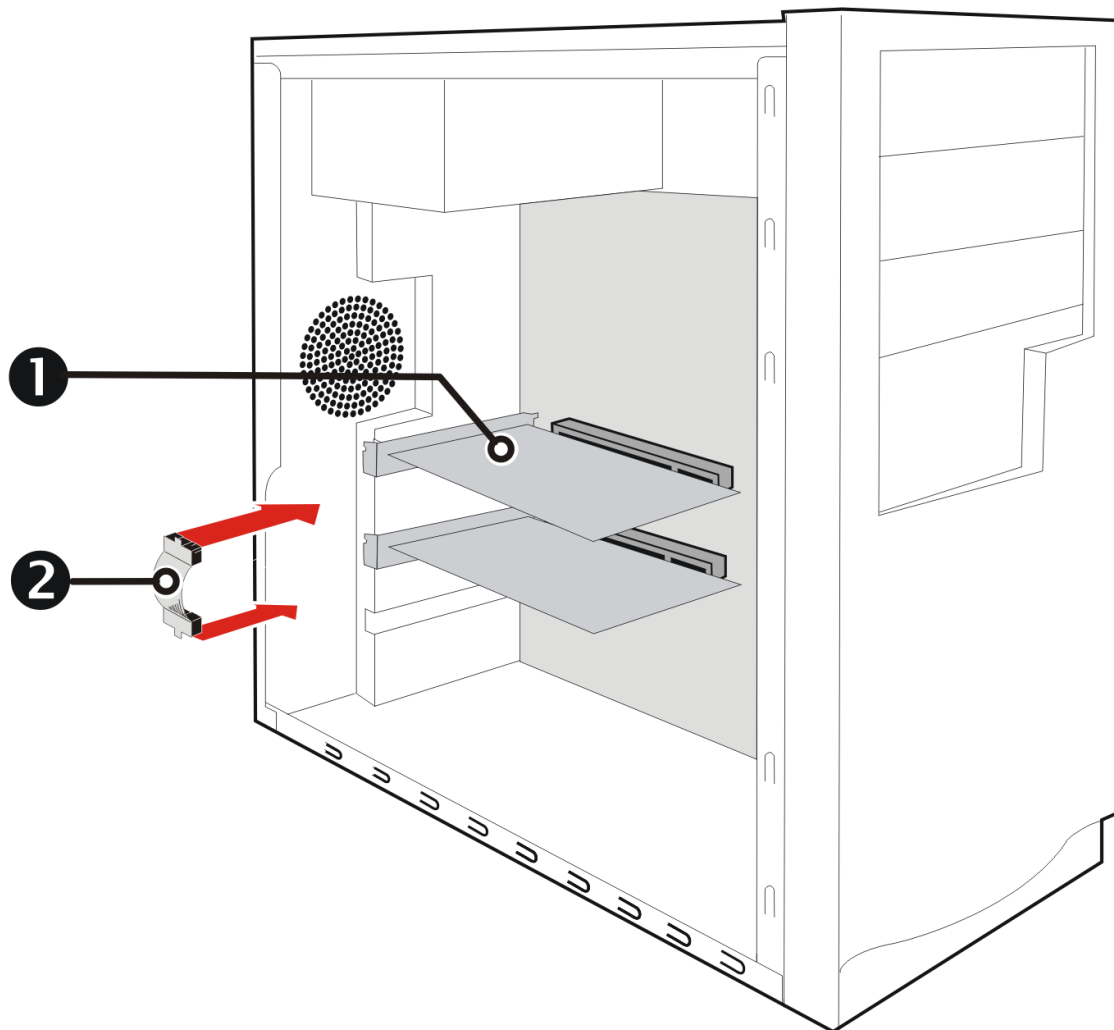

1	Newly installed AMD FirePro card
2	AMD CrossFire Pro Interconnect

9. Make sure that no cables are interfering with anything inside the computer (for example, a cooling fan) and then replace the computer cover.
10. Reconnect any cables you have disconnected and plug in the computer power cord.
11. Turn on the monitor and then the computer.



# Chapter 6

## Reference

---

This chapter provides notices, troubleshooting tips, and customer care, warranty, and standards-compliance information.

### 6.1 Product Features

This chapter describes some of the special features that are associated with the AMD FirePro™ W9000 product and are available through the Control Center software application.

**Note:** Feature availability varies between AMD FirePro™ products and operating systems.

#### 6.1.1 Stereoscopic Glasses

Your AMD FirePro graphics card can enable quad-buffer stereo display, which is used with special glasses to display images in 3D.

Quad buffering allows for smooth stereoscopic viewing under the following conditions:

- The **Enable Quad Stereo** option has been selected in the Control Center application through the **Workstation** aspect.

**Note:** You must reboot your system after enabling quad buffering for the first time.

- An appropriate quad buffer stereo mode has been selected in the Control Center application through the **Workstation** aspect.

**Note:** Refresh rates below 120 Hz will display noticeable “shutter” interference. Because many LCD displays cannot achieve a sufficient refresh rate, CRT displays are usually preferable.

##### 6.1.1.1 Quad Buffer Stereo Modes

The following modes are available:

- **Active Sync (Sync Signal Enabled):** Select this option for display devices connected to the active synchronization connector on the graphics card. The setting is selected by default.
- **Auto-Stereo (Vertical Interleaved):** Select this option for auto-stereo display devices that support vertically interleaved stereo image pairs.

- **Auto-Stereo (Horizontal Interleaved):** Select this option for auto-stereo display devices that support horizontally interleaved stereo image pairs.
- **Passive (Dual Head):** Select this option for passive stereo display devices that support dual video input.
- **Passive with Horizontal Invert (Dual Head):** Select this option for passive stereo display devices that support horizontally inverted stereo image pairs.
- **Passive with Vertical Invert (Dual Head):** Select this option for passive stereo display devices that support vertically inverted stereo image pairs.

The vertical and horizontal interleaved stereo modes are available only for graphics cards with auto-stereo support via a stereo 3D output.

Passive stereo modes can be enabled in Cloned Desktop mode only. When a passive stereo mode is selected, your system will automatically reboot and work in clone mode. Extended Desktop mode is not compatible with passive stereo modes.

## 6.1.2 Synchronization

### 6.1.2.1 Overview

In order for computing video applications to function properly with multiple displays or external video devices, special signal processing called “output locking” is required. Output locking synchronizes the display output of a GPU to a controlling signal, rather than allowing the display to refresh according to the state that a GPU finds itself in after being turned on. This controlling signal may be internally or externally generated, and function alone or in conjunction with other GPUs.

Output locking is required to ensure the video signals from multiple sources are synchronized, such as a video wall comprised of multiple small displays or when computer-generated graphics are combined with video from an external video camera.

**Genlock** (generator lock) is a type of output locking that synchronizes video outputs with an external reference signal generator.

**Framelock** is a synchronization method that uses output locking and also synchronizes 3D rendering on multiple GPUs.

Framelock and genlock for AMD FirePro workstation cards is provided by the ATI FirePro S400 synchronization module. Each synchronization module supports genlock and framelock for up to four GPUs per PC.

The following diagram shows the most important features of the S400.



Figure 6–1 ATI FirePro S400 Side View

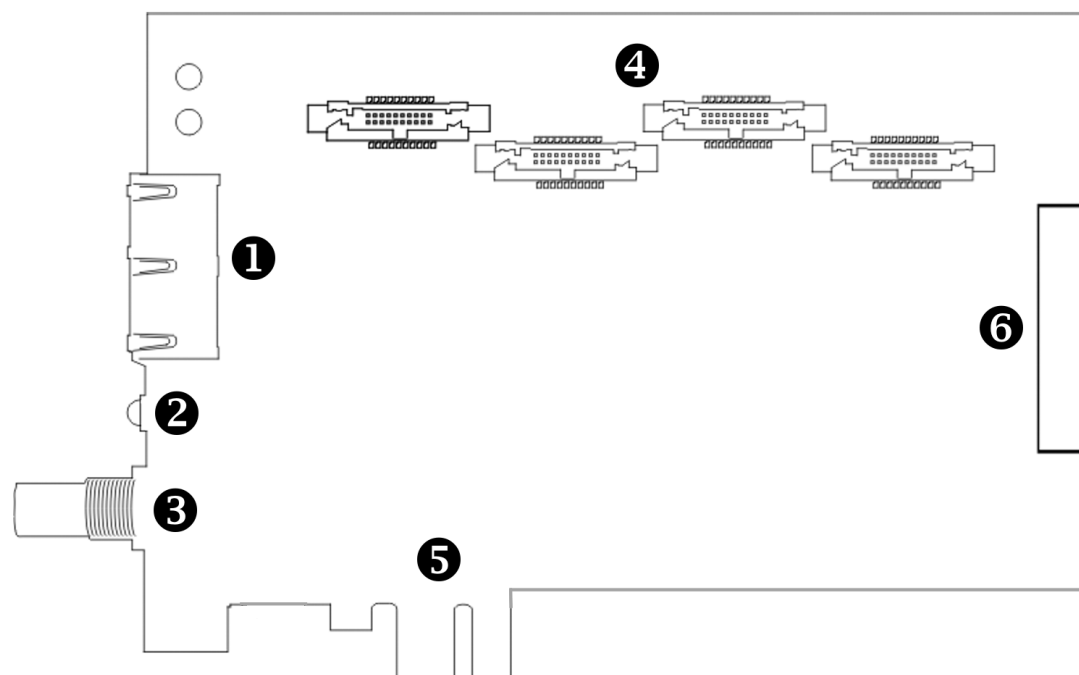

1	Two RJ-45 Connections for FrameLock
2	LED Indicator Light
3	BNC Connection for External Synchronization
4	Four Synchronization Module-to-GPU Connections
5	Physical Mounting (Unpowered)
6	SATA Power Connection

**Important:** Please note the following:

- The RJ-45 connections are **not** ethernet connections.
- The BNC connection should **not** be connected to a cable distribution system (or equivalent).

### 6.1.2.2 Genlock

Genlock is an example case of output locking.

Genlock refers to the ability to synchronize the pixel scanning of a GPU's display(s) to a synchronization signal that is generated outside the computer that the GPU is in. This ensures that video output sources from multiple video output devices (such as workstations, cameras, or video recorders) are combined or switched properly. Without proper synchronization, switching between sources may cause the picture to jump or be lost momentarily while the receiving device tries to lock to a new signal.

Genlock is commonly used in video post-production, nonlinear editing (NLE), and broadcast environment. Its use ensures that a workstation's graphics output is locked

to an externally generated signal, guaranteeing that devices (cameras, videotape recorders, character or title generators, and so on) work together effectively.

Typically, a workstation user plugs a “house sync” signal into the graphics board—typically set at NTSC (U.S.), PAL (Europe), or HDTV rates—instructing the graphics board to trigger various edges of the external sync signal. The house sync signal connects to the BNC connection on the AMD FirePro™ W9000.

The following diagram shows a single PC with four GPUs connected to an AMD FirePro™ W9000 synchronization module genlocked to an external signal generator.

Figure 6–2 Single PC with Four GPUs Genlocked to an External Signal Generator

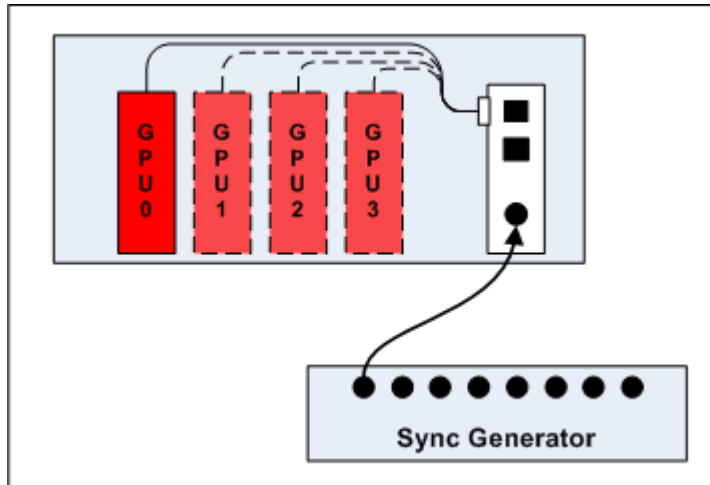

When a display device is genlocked, the rate at which pixels are shown on the display is matched to a timing signal generated by an external signal source. This type of synchronization can be used to coordinate the pixel scanning of displays connected to a single computer or displays connected across multiple computers.

A device providing a timing signal is known as a timing server, whereas a device using such a signal is known as a timing client.

**Timing Server.** A timing server provides the timing signal to which timing clients can be synchronized. The source of this signal can come from one of the following:

- A signal fed directly into the house sync (BNC) connection on the sync module.
- The display rate of a display device attached to the current computer.

**Timing Client.** A timing client synchronizes itself using the timing signal received from a timing server. Timing clients can be any number of the following:

- One or more displays attached to the current computer.
- Another computer connected downstream from the current computer via one or both of the RJ-45 connections on the sync module, essentially propagating the timing signal across a set of connected computers.

Use the **Workstation > Synchronization** page of Catalyst™ Control Center to select and configure timing clients and servers. You can also use this page to view the current status of external connections on the synchronization module.

**Note:** The settings on this page are available only if your computer is properly configured for synchronization. If necessary, follow the instructions on the page to correctly configure your computer.

### 6.1.2.3 Framelock

Framelock (sometimes called “frame synchronization”) refers to combining output locking with synchronized buffer swaps for 3D applications running across multiple windows. This type of synchronization can be used to coordinate the display of frames for applications on a single computer or across multiple computers. In framelocked systems with multiple computers, one (the timing server) is responsible for generating a synchronization signal for the others (the timing clients).

When graphics and video are displayed across multiple monitors on multiple computers, framelocked systems help maintain image refresh in sync. This allows images displayed on multiple monitors to create a large virtual canvas. For example, recent 4K resolution projection output devices require four DVI inputs to create one large 4K image.

Framelock is especially critical for stereo viewing, where the left and right fields must be in sync across all displays.

Framelock is most commonly used in simulation industries for displaying images to ensure seamless transition of objects from one window to another.

The following series of diagrams shows a variety of possible framelocking configurations.

The following image shows a single PC with four GPUs connected to an AMD FirePro™ W9000 synchronization module framelocked with an internal reference clock signal.

Figure 6–3 Single PC with Four GPUs Framelocked

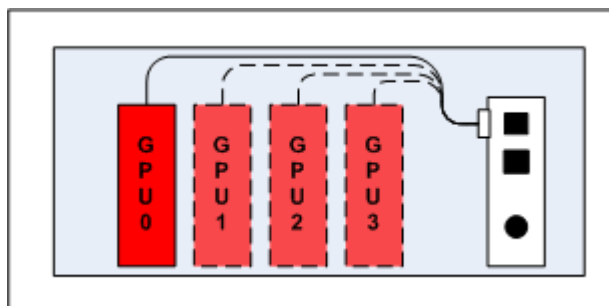

The following is an advanced framelock setup using two PCs with four GPUs each connected to an AMD FirePro™ W9000 synchronization module synchronized with an internal timing server running on one of the PCs.

Figure 6-4 Two PCs with Four GPUs Each Framelocked

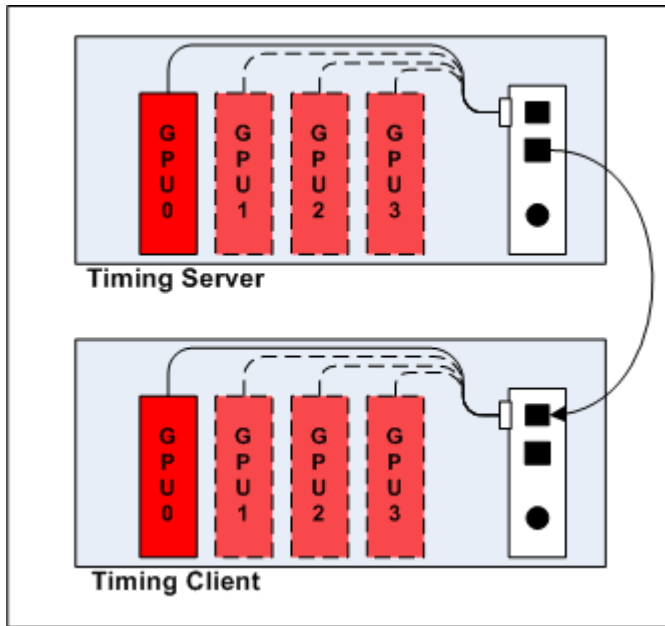

This diagram shows an advanced framelock and genlock setup using four PCs with four GPUs each; each computer is connected to an AMD FirePro™ W9000 synchronization module synchronized with an external signal generator.

Figure 6–5 Four PCs Framelocked and Genlocked

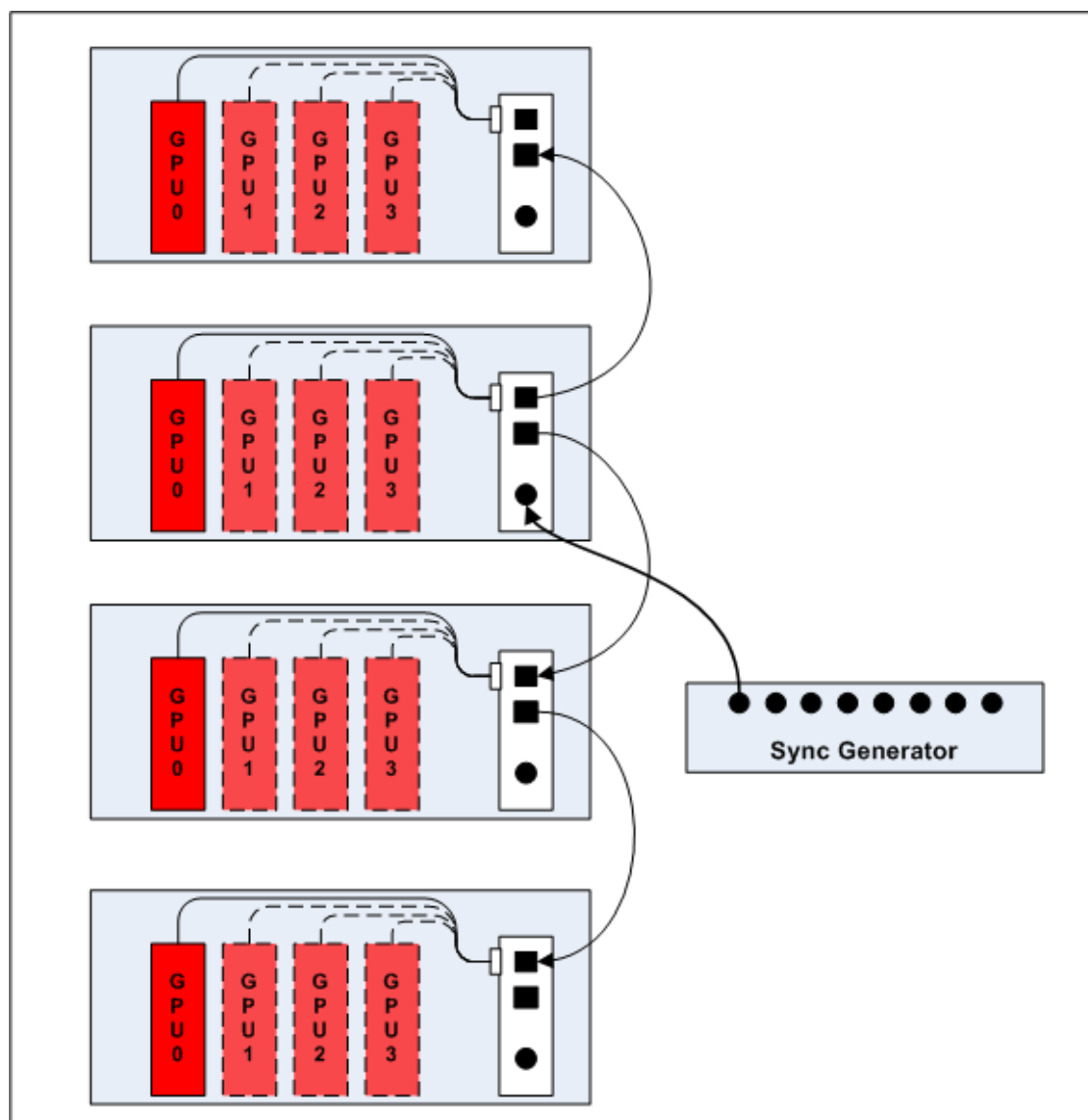

#### 6.1.2.3.1 Tips for Configuring Framelock

Framelock implementation is achieved using OpenGL extensions. For more information on whether your applications support these extensions, consult your software vendor.

Use the RJ-45 connections on the sync module to configure framelock across multiple computers. For framelock to be activated, all displays participating in a framelock configuration must be configured as active timing clients (through BNC/house sync or RJ-45).

For more information on synchronization features, see <http://ati.amd.com/products/workstation/synchronization.html>.

### 6.1.3 Hydravision

The **Hydravision** tab on the **Workstation** aspect of the Control Center application provides a number of display options.

### 6.1.3.1 Hydragrid

You can use HydraGrid to apply invisible grid layouts to desktops in single- and multi-display environments. When HydraGrid is enabled, application windows can be attached to individual cells in a grid, restricting their display to a specific area on a desktop.

HydraGrid preserves layouts on a per-user basis and is designed for window management across large, multiple, or virtual desktops.

**Note:** HydraGrid does not affect full-screen and non-resizable applications.

### 6.1.3.2 Desktop Manager

Desktop Manager contains options for configuring the behavior of application windows and dialogs in a multi-display environment. With Desktop Manager you can:

- Preserve and restore application window position and size.
- Maximize application windows across multiple displays.
- Reposition application dialog boxes.

**Tip:** To access the full capabilities of Desktop Manager, ensure you are working in a multi-display environment, as not all features are available in a single-display environment.

### 6.1.3.3 Multi Desktop

Using the Multi Desktop component of HydraVision, you can create and manage up to nine virtual desktops, each with their own display settings and background image. One desktop can be made visible at a time, while others can run in the background.

Using Multi Desktop, you can also:

- Switch between desktops using a mouse click or hot key.
- Run applications on a particular desktop or all desktops.
- Move running applications between desktops.
- Save, restore, and delete desktop profiles.

## 6.1.4 DisplayPort Audio

DisplayPort audio requires up-to-date graphics drivers, and the display device must support DisplayPort audio.

As with HDMI™, DisplayPort audio is enabled through Windows®. For more information, consult your Windows documentation.

## 6.2 Workstation Card Troubleshooting

The following troubleshooting tips may help if you experience problems.

More troubleshooting information can be found using the knowledgebase on the AMD Web site at <http://support.amd.com/>.

### 6.2.1 Computer does not boot up properly.

Verify that the installation instructions were properly followed. In particular, if external power is required, make sure that the external power cable (or cables) is properly connected.

Check that the card is properly installed in your system and connected to your monitor.

If you have problems during start-up, restart your computer in Safe Mode.

Check the system configuration utility of your operating system for the interrupt assignments.

Contact AMD's Customer Care or your local technical support.

### 6.2.2 There is no display.

Make sure the card is seated properly in its slot. If external power is required, make sure that the external power cable (or cables) is properly connected to the card.

Make sure that the monitor cable is securely fastened to the card.

Make sure that the monitor and computer are plugged in and receiving power.

If necessary, disable any built-in graphics capabilities on your motherboard. For more information, consult your computer's manual or manufacturer.

**Note:**

- Some manufacturers do not allow the built-in graphics to be disabled or to become the secondary display.
- If your system has built-in graphics capabilities, make sure that you uninstall the associated driver to prevent conflicts with AMD graphics drivers.

Make sure that you selected the appropriate monitor when you installed your enhanced driver.

Make sure that the display resolution and refresh rate settings you have selected are supported by the monitor you have connected.

### 6.2.3 There are screen defects.

Make sure your monitor supports the resolution and horizontal (kHz) and vertical (Hz) refresh rates as required by the graphics card. Check your current resolution, refresh rate, and color depth settings in the Settings and Monitor tabs in your Display Properties dialog.

**Caution:**

Ensure that both the graphics card and monitor support the resolution and refresh rates you select. Incompatible resolution/refresh rate selection may result in monitor damage. Refer to your monitor's documentation for recommended resolutions and refresh rates.

## 6.2.4 The screen image is off-center or there are odd colors.

Try adjusting the brightness, sharpness, contrast, and color balance controls of your monitor.

Try adjusting the centering and positioning controls of your monitor to position the picture on the screen.

Set the monitor's RGB inputs (and sync switches, if this option is available) to 75 Ohms, with the sync set to external.

**DFP monitor users:** Make sure that the DVI plug of your monitor data cable is digital-only (DVI-D), not integrated analog/digital (DVI-I). Refer to your monitor's documentation and contact your supplier or the manufacturer of the DFP monitor for information on how to obtain a suitable data cable plug.

If you need to use DisplayPort or Mini DisplayPort adapters other than the ones included with your graphics card, make sure that you use AMD Eyefinity validated dongles. For more information, see <http://support.amd.com/us/eyefinity/Pages/eyefinity-dongles.aspx>.

## 6.2.5 The operating system warns that the graphics card isn't properly configured.

Make sure that the display resolution and refresh rate settings you have selected are supported by the monitor you have connected.

Check the driver installation and make sure that all software is correctly loaded corresponding to your operating system and applications.

Reinstall the drivers for your graphics card.

## 6.2.6 There are bus address or interrupt conflicts.

Make sure that the I/O and memory addresses reserved for the graphics board are not used by other hardware devices. The integrated on-board VGA controller of your AMD FirePro card uses the following addresses (hex):

- **I/O Address:** Standard VGA I/O: 3B0-3DF
- **Memory Addresses:** Video RAM: A000-BFFF, Video ROM: C000-C7FF

You cannot change the addresses of your AMD FirePro card. In case of an address conflict, try to modify the I/O address of the add-on card that causes the conflict.

To support the special graphics processor on the AMD FirePro card, the system BIOS should automatically assign a system interrupt to the slot where the card is installed. However, there may be problems if your graphics card does not receive an interrupt or a system interrupt is used for more than one device. In case of problems, check the system configuration utility of your operating system for the interrupt assignments.



## 6.3 Workstation Customer Care

The AMD Customer Care Web site has number of helpful resources, including a knowledgebase of FAQs, warranty services, and the AMD FirePro Workstation Graphics Web Ticket Submission Page.

The Web site is complimentary and available at all times. The address is <http://support.amd.com>.

### 6.3.1 Contact Information

If you experience difficulties with your AMD FirePro product, you can contact AMD Customer Care in the following ways.

The latest contact information and tips for faster service can be found on the AMD Global Technical Support page at <http://support.amd.com/us/contacts/Pages/global-technical-support.aspx>.

### 6.3.2 Disclaimer

AMD Customer Care will work to resolve your issue and help you to get your product up and running. If your issue is not resolved, our technicians will determine whether the difficulty you are experiencing is the result of the product, whether your product contains a defect, and whether your product should be returned to AMD for warranty service.

AMD Customer Care is unable to assist with refunds, returns, or exchange-specific inquiries. If resolving the problem being experienced is critical to your decision to keep the product, it is your responsibility to ensure that you know and are within the period of time your reseller will allow for refunds, returns, or exchange.

AMD is not responsible for any expense incurred accessing Customer Care. It is expected that customers will review the expense associated with the available support options and will choose the method that best meets their needs and budget.

AMD Customer Care reserves the right to limit support options for products that are not registered or are at End of Life.

## 6.4 Workstation Warranty Service

For warranty service instructions visit <http://support.amd.com/us/warranty/Pages/SupportWarrantyServices.aspx> or contact one of our Customer Service Representatives.

### 6.4.1 Shipping

Before shipping any unit for repair, obtain an RMA number for warranty service.

When shipping your product, pack it securely, show the RMA and serial number of the product on the outside, and ship prepaid and insured.

AMD will not be held liable for damage or loss to the product in shipment.

Standard warranty service consists of repair upon receipt.

AMD reserves the right to replace the product with a serviced product at their sole discretion at any time.

You are responsible for the cost of shipping the product to AMD. AMD pays the cost of returning the product to you.

Products which are repaired under warranty are guaranteed for the remainder of the original warranty period. Repairing or exchanging a product does not start a new warranty period. If, at the time of repair, a product is already "out of warranty" or within the last 90 days of the warranty period, AMD will guarantee the repair for the full 90 days. All other terms and conditions of the original warranty apply.

## 6.4.2 Limitations

All warranties for this product, expressed or implied, will expire three (3) years from date of original purchase.

All accompanying cables and accessories are warranted for 90 days.

No warranties for this product, expressed or implied, shall extend to any person who purchases the product in a used condition.

The liability of AMD in respect of any defective product will be limited to the repair or replacement of such product. AMD may use new or equivalent-to-new replacement parts. Defective product will be sent in for repair or replacement only. AMD makes no other representations or warranties as to fitness for a particular purpose, merchantability or otherwise in respect of the product. No other representations, warranties or conditions, shall be implied by statute or otherwise. In no event shall AMD be responsible or liable for any damages, including but not limited to the loss of revenue or profit, arising:

- From the use of the product, as a result of any event, circumstance, action or abuse beyond the control of AMD; whether such damages be direct, indirect, consequential, special or otherwise and whether such damages are incurred by the person to whom this warranty extends or a third party
- From the loss of use of the product, as a result of any event, circumstance, action or abuse beyond the control of AMD; whether such damages be direct, indirect, consequential, special or otherwise and whether such damages are incurred by the person to whom this warranty extends or a third party.

Unauthorized repairs to an AMD board level product will void the warranty offered by AMD. AMD reserves the right to refuse to service any product which has been altered, modified, or repaired by non-AMD service personnel.

## 6.5 International Compliance Information

This section details the worldwide compliance information for this product, which is manufactured to be compliant in the regions where it is sold.

AMD products are either Class A or Class B compliant and are indicated accordingly on the compliance label for each product. The following regulatory information applies to Class A and Class B products.

## 6.5.1 FCC Compliance Information (USA)

### Class A

This device complies with Part 15 of the FCC Rules. Operation is subject to the following conditions: (1) this device may not cause harmful interference and (2) this device must accept any interference received, including interference that may cause undesired operation.

**Note:** This equipment has been tested and found to comply with the limits for a Class A digital device, pursuant to Part 15 of the FCC Rules. These limits are design to provide reasonable protection against harmful interference when the equipment is operated in a commercial environment. This equipment generates, uses, and can radiate radio frequency energy and, if not installed and used in accordance with manufacturer's instructions, may cause harmful interference to radio communications. Operation of this equipment in a residential area is likely to cause harmful interference in which case, the user will be required to correct the interference at his own expense.

### Warning:

Changes or modifications to this device not expressly approved by Advanced Micro Devices, Inc. could void the user's authority to operate the equipment.

FCC Part 15, Subpart B, Class A

### Class B

This product complies with FCC Rules Part 15. Operation is subject to the following conditions:

- This device may not cause harmful interference.
- This device must accept any interference received, including interference that may cause undesired operation.

This equipment has been tested and found to comply with the limits designed to provide reasonable protection against harmful interference in a residential installation. This equipment generates, uses and can radiate radio frequency energy and, if not installed and used in accordance with manufacturer's instructions, may cause harmful interference to radio communications. However, there is no guarantee that interference will not occur in a particular installation. If this equipment does cause harmful interference to radio or television reception, which can be determined by turning the equipment off and on, the user is encouraged to try to correct the interference by one or more of the following measures:

- Re-orient or relocate the receiving antenna.
- Increase the separation between the equipment and receiver.
- Connect the equipment to an outlet on a circuit different from that to which the receiver is connected.
- Consult the dealer or an experienced radio/TV technician for help.

The use of shielded cables for connection of the monitor to the graphics card is required to ensure compliance with FCC regulations. Changes or modifications to this unit not expressly approved by the party responsible for compliance could void the user's authority to operate this equipment.

**Caution:**

Changes or modifications not expressly approved by the party responsible for compliance could void the user's authority to operate the equipment.

FCC 15, Subpart B, Class B

**For further compliance information:**

Advanced Micro Devices, Inc.  
1 AMD Place  
P.O. Box 3453  
Sunnyvale, CA 94088-3453  
USA Tel: 408-749-4000

## 6.5.2 Industry Canada Compliance Statement (Canada)

**Class A**

This Class A digital apparatus complies with Canadian ICES-003.

Cet appareil numérique de la Classe A est conforme à la norme NMB-003 du Canada.

**Class B**

This Class B digital apparatus complies with Canadian ICES-003.

Cet appareil numérique de la Classe B est conforme à la norme NMB-003 du Canada.

## 6.5.3 CE Compliance Information (European Union)

**Class A****Warning:**

This is a Class A product. In a domestic environment this product may cause radio interference in which case the user may be required to take adequate measures.

EMC Directive 2004/108/EC

CISPR 22/EN 55022—Class A: Limits and methods of measurement of radio disturbance characteristics of Information Technology Equipment.

CISPR 24/EN 55024—Information Technology Equipment—Immunity Characteristics—Limits and Methods of Measurements

**Class B**

EMC Directive 2004/108/EC

CISPR 22/EN 55022—Class B: Limits and methods of measurement of radio disturbance characteristics of Information Technology Equipment.

CISPR 24/EN 55024—Information Technology Equipment—Immunity Characteristics—Limits and Methods of Measurements

## 6.5.4 Electrical Safety

Europe: The Low Voltage Directive–2006/95/EC

- EN 60950-1–Safety of Information Technology Equipment

USA/Canada:

- UL 60950-1 (Information Technology Equipment–Safety–Part 1: General Requirements)
- CSA C22.2 No. 60950-1 (Information Technology Equipment–Safety–Part 1: General Requirements)

International:

- IEC 60950-1 (Information Technology Equipment–Safety-Part 1: General Requirements)

To meet UL safety requirements, the computer's maximum room temperature should not exceed 40 °C.

This product complies with the PCI Express 300W Electromechanical Specification – please refer to the manufacturer for additional information. Other relevant input power data will also be available.



## 6.5.5 VCCI ITE Compliance Information (Japan)

**Class A**

この装置は、クラスA 情報技術装置です。この装置を家庭環境で使用すると電波妨害を引き起こすことがあります。この場合には使用者が適切な対策を講ずるよう要求されることがあります。

VCCI-A

Translation:

This is a Class A product based on the standard of the VCCI Council. If this equipment is used in a domestic environment, radio interference may occur, in which case, the user may be required to take corrective actions.

VCCI V-3

**Class B**



この装置は、クラスB 情報技術装置です。この装置は、家庭環境で使用することを目的としていますが、この装置がラジオやテレビジョン受信機に近接して使用されると、受信障害を引き起こすことがあります。

取扱説明書に従って正しい取り扱いをして下さい。

VCCI-B

Translation:

This is a Class B product based on the standard of the VCCI Council. If this is used near a radio or television receiver in a domestic environment, it may cause radio interference. Install and use the equipment according to the instruction manual.

VCCI V-3

### 6.5.6 KC Certification Information (Korea)



**Class A**

**A급 기기 (업무용 정보통신기기)**

이 기기는 업무용으로 전자파적합등록을 한 기기이오니 판매자 또는 사용자는 이 점을 주의하시기 바라며, 만약 잘못판매 또는 구입하였을 때에는 가정용으로 교환하시기 바랍니다.

Translation:

"Class A" Equipment (Business purpose info/telecommunications equipment)

As this equipment has undergone EMC registration for business purpose, the seller and/or buyer is asked to beware of this point and in case a wrongful sale or purchase has been made, it is asked that a change to household use be made.

KN22 and KN24

**Class B**

**B급기기(가정용 방송통신기기)**

이 기기는 가정용(B급)으로 전자파적합등록을 한 기기로서 주로 가정에서 사용하는 것을 목적으로 하며, 모든 지역에서 사용할 수 있습니다.

Translation:

"Class B" Equipment (Household purpose info/telecommunications equipment)

As this equipment has undergone EMC registration for household purpose, this product can be used in any area including residential area.

KN22 and KN24

### 6.5.7 BSMI Certification Information (Taiwan)

Class A

**警告使用者：**  
**這是甲類的資訊產品，在居住的環境中使用時，可能會造成射頻干擾，在這種情況下，使用者會被要求採取某些適當的對策。**

Translation:

This is a Class A Information Product, when used in residential environment, it may cause radio frequency interference, under such circumstances, the user may be requested to take appropriate countermeasures.



CNS13438

Class B



CNS13438

### 6.5.8 C-Tick (Australia and New Zealand)



ACMA — Australian Communications and Media Authority

- Radiocommunications Act 1992 (Australia)—per notices of section 182
- AS/ NZS CISPR 22

### 6.5.9 Product Environmental Compliance

This product may carry a marking similar to those below that indicates its level of compliance with China RoHS standards.



For information on China RoHS, EU RoHS, or EU REACH compliance, please refer to [Product Environmental Compliance](#) on the AMD Web site.

### 6.5.10 Waste Electrical and Electronic Equipment (WEEE) Directive Compliance (European Union)

This product was manufactured by Advanced Micro Devices, Inc.

