

HONDA

Power

Equipment

OPERATOR'S MANUAL

BC1000 BAGGER CART

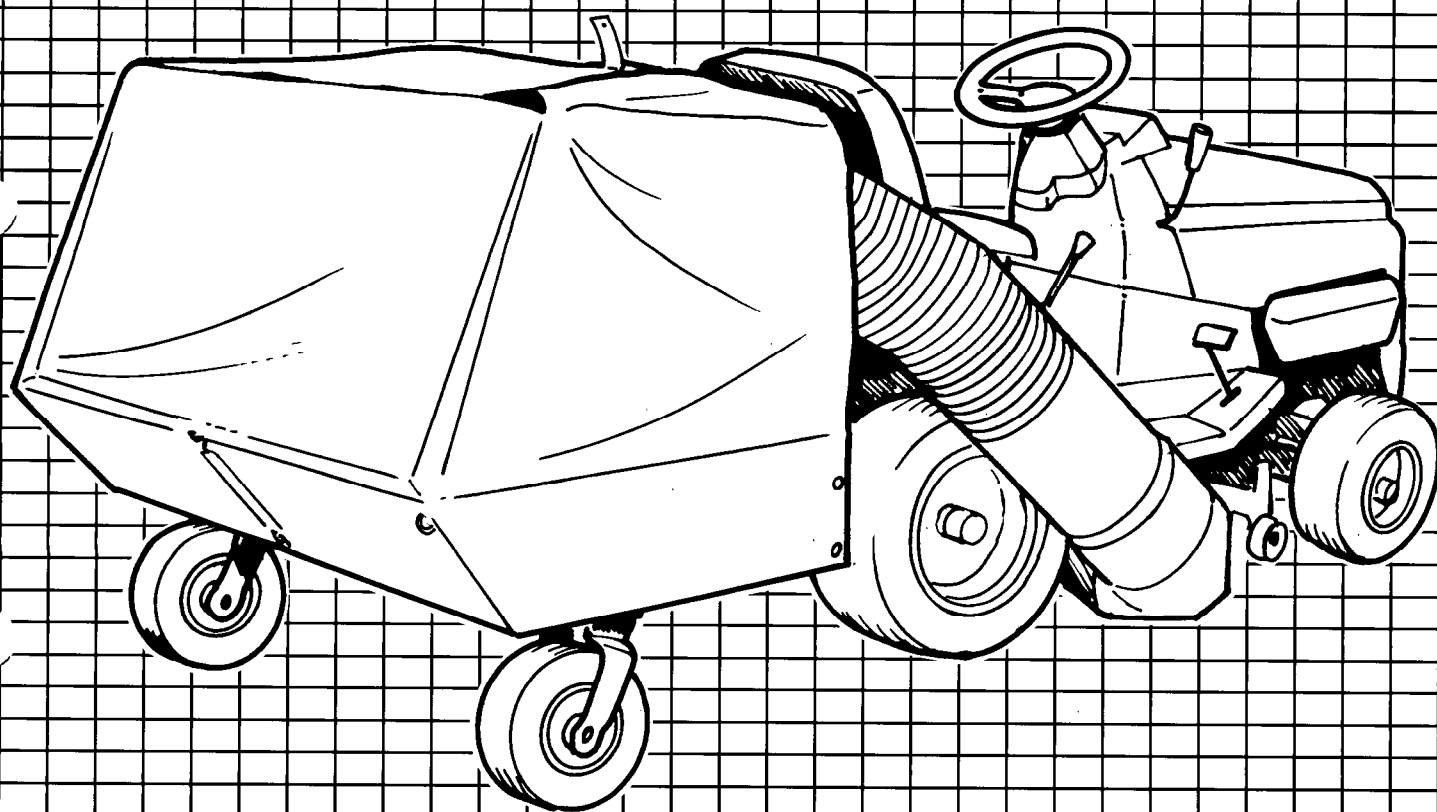

HONDA DEALER: PLEASE GIVE THIS PUBLICATION TO YOUR CUSTOMER

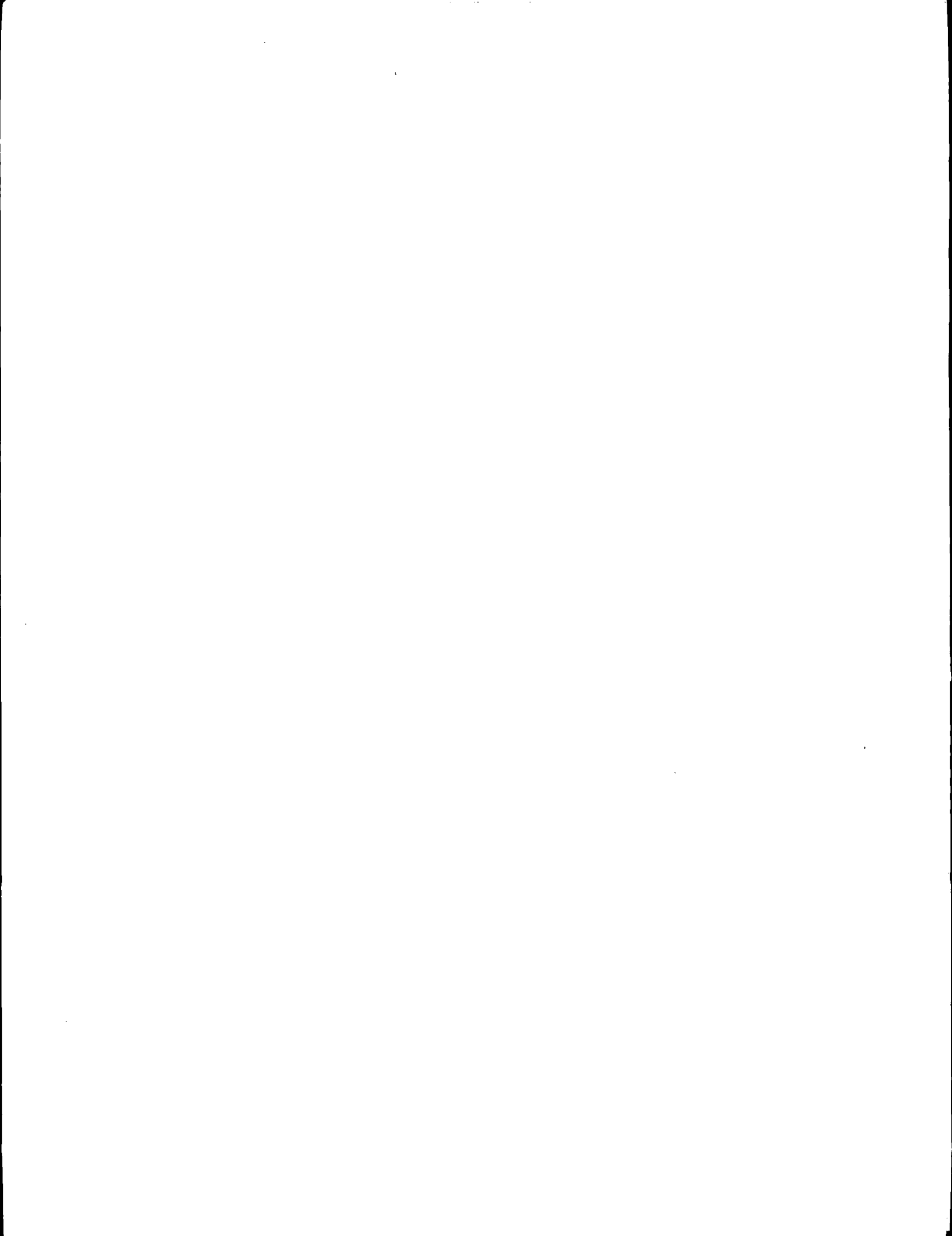

A FEW WORDS ABOUT SAFETY

Your safety and the safety of others are very important. And using this bagger cart is an important responsibility.

To help you make informed decisions about safety, we have provided operating procedures and other information on labels and in this manual. This information alerts you to potential hazards that could hurt you or others.

Of course, it is not practical or possible to warn you about all the hazards associated with operating a bagger cart. You must use your own good judgement.

You will find important safety information in a variety of forms, including:

- **Safety Labels**—on the bagger cart.
- **Safety Messages**—preceded by a safety alert symbol  and one of the following three words; **DANGER**, **WARNING**, or **CAUTION**.

These words mean:

DANGER

You **WILL** be **KILLED** or **SERIOUSLY HURT** if you don't follow instructions.

WARNING

You **CAN** be **KILLED** or **SERIOUSLY HURT** if you don't follow instructions.

CAUTION

You **CAN BE HURT** if you don't follow instructions

- **Safety Headings**—such as **IMPORTANT SAFETY INFORMATION**
- **Safety Sections**—such as **BAGGER CART SAFETY**
- **Instructions**—how to use this bagger cart correctly and safely.

This entire book is filled with important safety information—please read it carefully.

TABLE OF CONTENTS

SAFETY	2
SAFETY LABELS	2
CONTROLS	3
CONTROLS	3
BEFORE OPERATION	4
GENERAL	4
CHECK MOWING AREA	4
PROTECTIVE CLOTHING	4
INSPECT THE BAGGER CART	4
IMPORTANT SAFETY INFORMATION	5
IMPORTANT SAFETY INFORMATION	5
OPERATION	6
CONNECTING THE BAGGER CART	6
STARTING AND STOPPING	7
MOWING	7
USE AS A UTILITY CART	9
MAINTENANCE	10
MAINTENANCE SAFETY	11
MAINTENANCE SCHEDULE	12
ASSEMBLY	13
THE IMPORTANCE OF ASSEMBLY	13
IMPORTANT SAFETY PRECAUTIONS	13
REQUIREMENTS	14
TORQUE VALUES	14
HARDWARE MEASURING CHART	14
PARTS LIST	15
ASSEMBLY	17
TRANSPORTING / STORAGE	24
TRANSPORTING	24
STORAGE	24
SPECIFICATIONS	25
SPECIFICATIONS	25
PARTS	26
PARTS	26
ADDITIONAL INFORMATION	28
HONDA PUBLICATIONS	28
WARRANTY SERVICE INFORMATION	28

SAFETY LABELS

The label shown here contains important safety information. Please read it carefully. This label is considered a permanent part of your side blower. If the label comes off or becomes hard to read, immediately contact an authorized Honda servicing dealer for a replacement label.

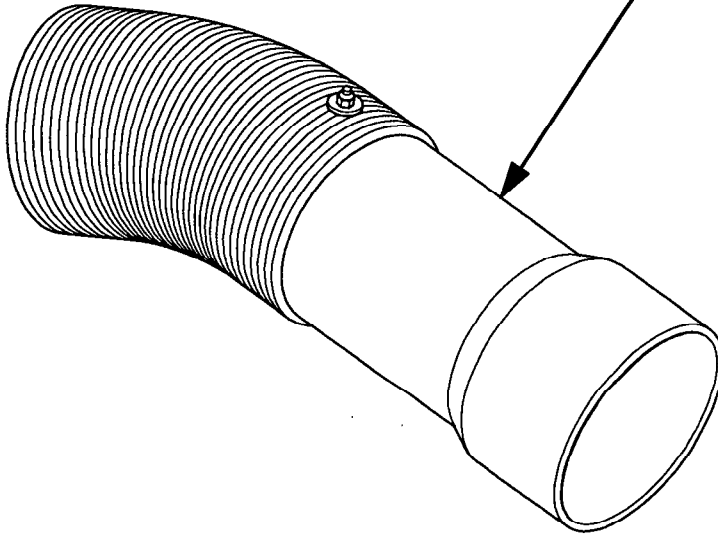

CONTROLS

This chapter shows the bagger cart control locations and it tells you how the bagger controls work. It only covers controls relating to the bagger cart. Have your Honda tractor owner's manual handy for reference while reading this chapter.

Rubber Strap

This rubber strap holds the cover open or closed. The strap connects to the frame washer to hold the cover closed, or the grommet strap to hold it open.

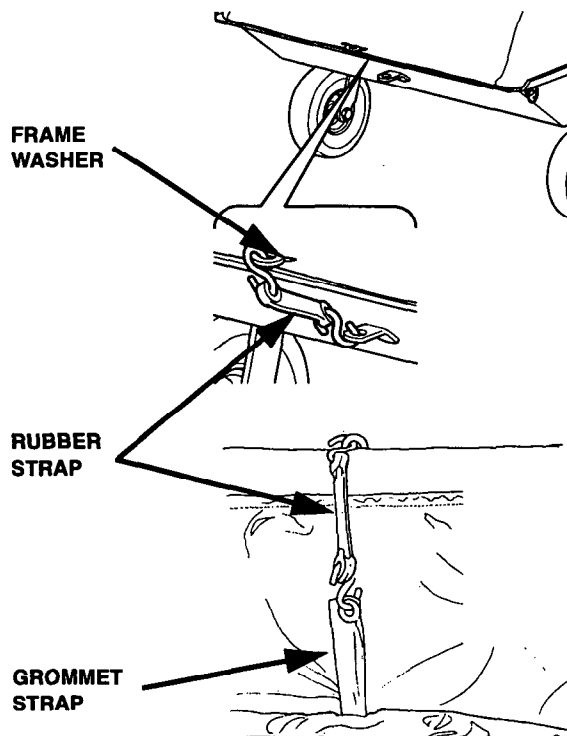

Dump Cloth

Use the dump cloth to empty the cart without tilting it. The dump cloth lets you pull the clippings out easily.

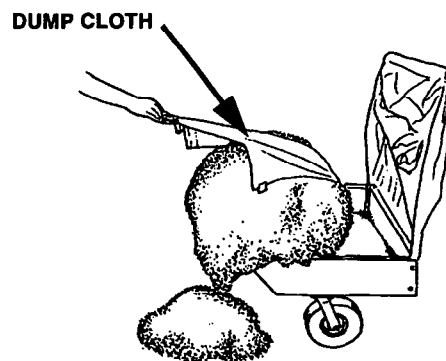

Latch Handle

The latch handle is used to release the cart bed from the frame, so the cart bed can be tilted.

Lift Handle

Use the lift handle to tilt the cart bed after the latch handle has been released.

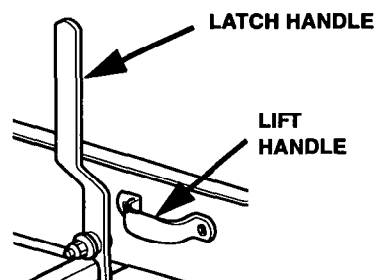

BEFORE OPERATION

GENERAL

For your safety, and to prolong the service life of your equipment, always inspect the bagger cart before each use. Refer to the MAINTENANCE SCHEDULE on page 12.

Perform the *Before Operation* checks listed in the tractor's manual.

CHECK MOWING AREA

For your safety and the safety of others, always inspect the area before mowing.

Objects

Anything which can be picked up by the mower deck is a potential hazard to you and others. Always remove any large debris from the mowing area.

Remove motor vehicles or other objects from the mowing area to prevent them from getting damaged.

People and Pets

People and animals near the mowing area can move into your path. Clear the area of pets, people, and especially children. Their safety is your responsibility.

PROTECTIVE CLOTHING

Be sure to wear protective clothing such as long pants and eye protection which can lower your risk of injury. Wear footwear that protects your feet. Wear ear protection to protect your hearing.

Do not wear loose fitting clothing, jewelry, scarves, ties, etc., which may get caught in moving parts. Tie up or restrain long hair.

Wear a dust mask when mowing in dusty conditions.

INSPECT THE BAGGER CART

Check the mounting bracket on the tractor, the clevis pins, spring clips and rubber straps and make sure they are all secure. Do not operate the bagger cart with any missing parts

Check the latch handle and make sure it has properly locked the cart bed to the frame.

Be sure the cover is secured down and the upper chute is properly attached before mowing.

IMPORTANT SAFETY INFORMATION

Before operating the lawn tractor with the bagger cart installed for the first time, please review the safety information in the lawn tractor owner's manual, and the previous chapter of this book, *BEFORE OPERATION*.

For your safety, avoid starting or operating the tractor's engine in an enclosed area such as a garage. Your tractor's engine exhaust contains poisonous carbon monoxide gas which can collect rapidly in an enclosed area and cause illness or death.

The following precautions are suggested to help prevent accidents. Most accidents can be avoided by observing certain precautions. Read the following precautions before operating the bagger cart to help prevent accidents. Equipment should be operated only by those who are responsible and instructed to do so.

Operator Responsibility

- Do not allow anyone to ride on the bagger cart.
- Always move the PTO lever/knob to OFF, shut the engine OFF, remove the ignition key, and wait for all moving parts to stop before leaving the operator's position, leaving the bagger cart unattended or inspecting the bagger cart.
- Be sure the area is clear of other people before operation. Stop the machine if anyone enters the area. Do not operate the bagger cart with children, pets or others nearby.
- Watch out for traffic when operating near or crossing roadways. Slow down before turning and approach blind corners cautiously.
- Always observe the area ahead. Avoid obstacles and stay away from holes, ditches, soft or steep embankments and other potentially dangerous areas.
- Wet surfaces reduce traction and stability. Always maintain proper traction.
- Stop the tractor's engine, then set the parking brake ON before connecting, disconnecting, or unloading the bagger cart.

Children

- Accidents can occur if the operator is not alert to the presence of children. Children are often attracted to the machine and the tractor's activity. Never assume that children will remain where you last saw them.
- Keep children out of the work area and under the watchful eye of another responsible adult.
- Be alert and turn off the machine if children enter the area.

Operation

- Read the tractor owner's manual carefully. Be thoroughly familiar with the controls and proper use of the tractor. Know how to stop the tractor and disengage the controls quickly.
- Refer to the tractor owner's manual for detailed instructions on starting the engine and parking.
- Always remain in the operator's seat of the tractor when operating the lawn tractor.
- If you strike a foreign object, move the PTO knob to OFF, shut the engine OFF, and remove the ignition key. Inspect for and repair any damage before operating the lawn tractor and bagger cart again.

OPERATION

CONNECTING THE BAGGER CART

Park the tractor on a flat, level surface. Set the parking brake and remove the ignition key to prevent accidental starting. The following instructions are for the HA4118 and HA4120 tractors only. Refer to the hitch kit installation instructions for other tractor models.

1. Lift the bagger cart frame towards the rear hitch. Install the two clevis pins and spring clips as shown.

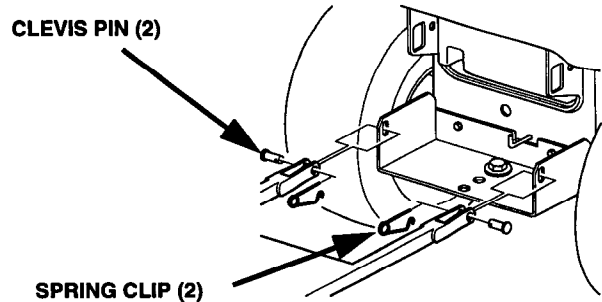

2. **HA4120 with the 48" Deck:** Lift the middle chute and install it on the lower chute on the side blower. Connect the rubber strap to the tension release lever.

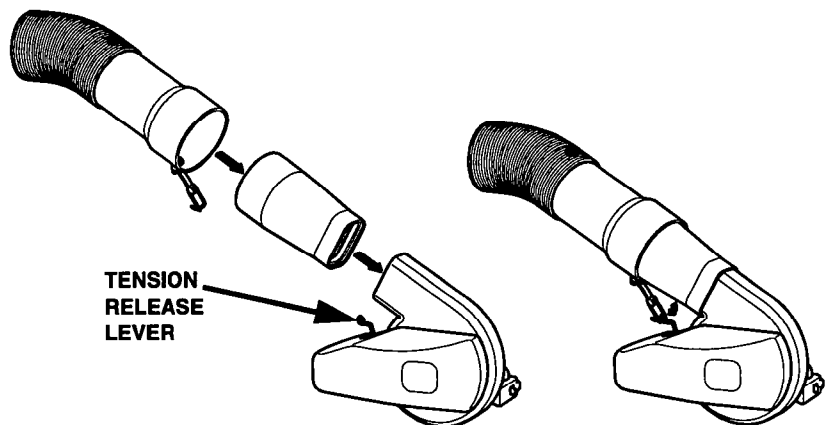

3. **HA4118 with the 38" Deck:** Lift the discharge guard, and install the lower chute onto the rear edge of the mower deck first, then turn the chute toward the front. Install the connector bracket and clip onto the mower deck. Slide the middle chute onto the lower chute, then connect the S-hook on the rubber strap to the eyelet on the lower chute.

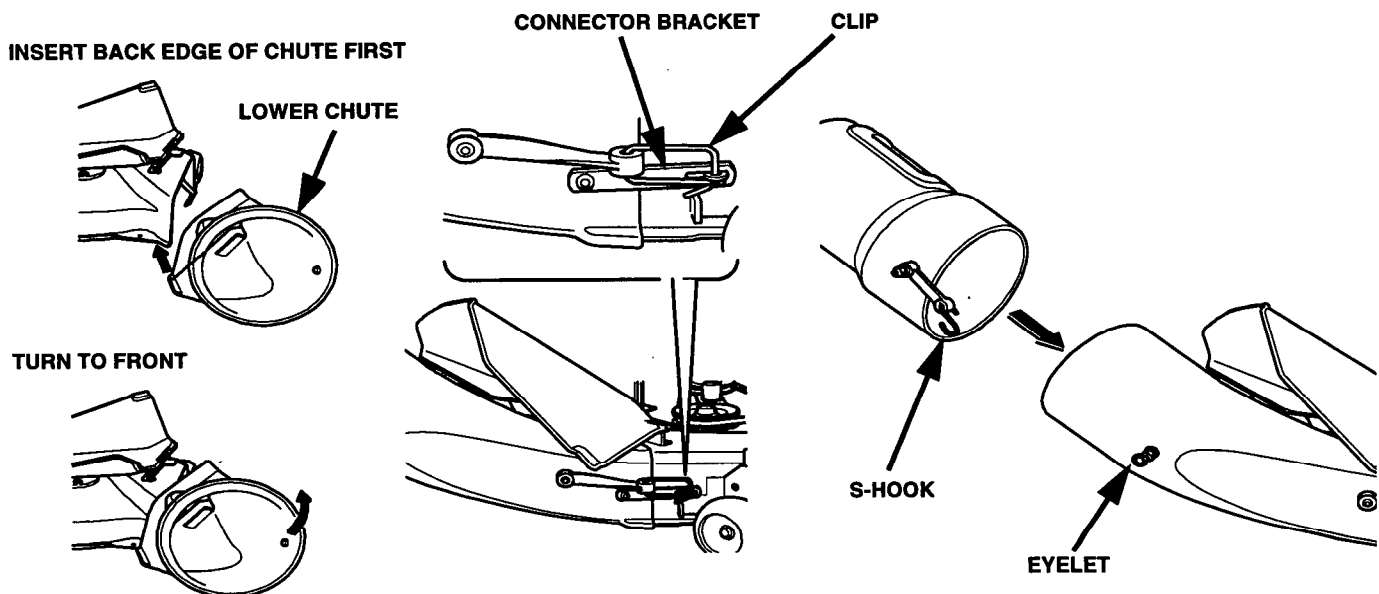

STARTING AND STOPPING

The bagger cart adds weight (especially when filled) that can change the way the tractor handles. Operate the tractor at a slower speed when using the bagger cart. This will make the tractor and bagger cart easier to operate and control. Start in a lower gear (or speed) and plan stops further in advance when using the bagger cart.

MOWING

The bagger cart holds a large amount of clippings that can change the way the tractor handles. The bagger cart works best when the tractor is driven at slower speed which will maximize the finished appearance of your lawn.

Slopes

Avoid operation on slopes, hills, ditches or other uneven terrain. Do not operate the tractor and bagger cart on a slope greater than 15 degrees. If you must mow on slopes, do it first, when the bagger cart is empty and dump the clippings before the cart becomes half-full.

Refer to the owner's manual for your tractor for more specific operational techniques when you must operate on a sloped surface.

Operation in Reverse

As a general rule, do not operate the bagger cart in reverse. If it is absolutely necessary to back up:

1. Move the PTO clutch lever/knob to OFF.
2. Check the area on the ground directly behind the bagger cart.
3. Continue to observe area behind the bagger cart while backing up.

Tips

Avoid using the bagger cart (or even mowing at all) when the grass is wet. Wet clippings can quickly clog the mower deck, and the lower, middle and upper chutes of the bagger cart.

Watch the window on the middle chute. If clippings aren't flowing past the window, the chute or mower deck may be clogged. See the next section on how to clear a clogged chute.

Make sure the mower deck blades are sharp. For sharpening guidelines, refer to the owner's manual for your tractor.

Always keep the throttle in the FAST position when mowing. This cuts the grass better, and helps blow the clippings out of the mower deck.

Clearing a Clog

At times, it is possible the chute may become clogged. If this happens, stop the lawn tractor, move the PTO knob/lever to OFF, set the parking brake ON, and remove the ignition key before attempting to clear a clog.

1. Disconnect the upper or lower rubber strap (as needed) from the middle chute. Use a stick (never your hands) to clear the clogged grass out of the chute(s).
2. Be sure to reattach all straps and chute parts before operating the tractor or bagger cart.

OPERATION

Emptying the Bagger Cart

Use the inspection window in the top cover to check the clipping level. When you see grass collecting at the window level, the cart must be emptied. Make sure the PTO clutch lever/knob is OFF. Back the tractor up to the location where you want to empty the clippings. Stop the tractor, set the parking brake ON, and remove the ignition key.

Unhook the rubber strap from the cover on the rear of the bagger cart. Pull the cover over the top of the frame, and hook the rubber strap to the grommet strap near the inspection window. This will hold the cover in place and out of your way when emptying the bagger cart.

Empty the clippings by using the dump cloth (if installed) or by tipping the cart bed:

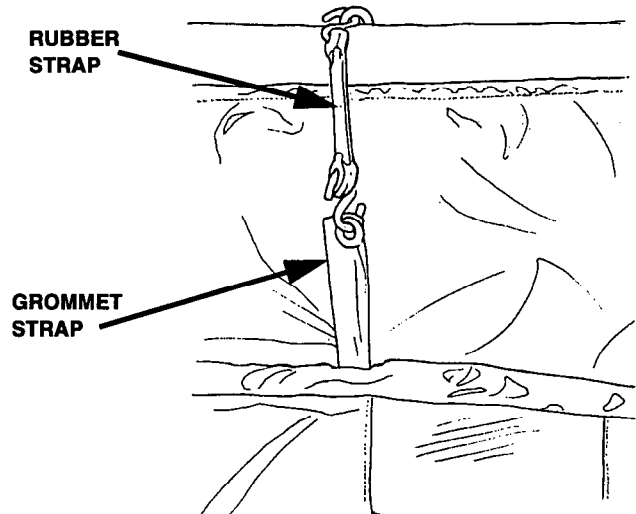

USING THE DUMP CLOTH:

1. Unhook the four plastic clips from the frame.
2. Pull the dump cloth away from the bagger cart using the fabric handles.
3. Hook the plastic clips back to the frame.

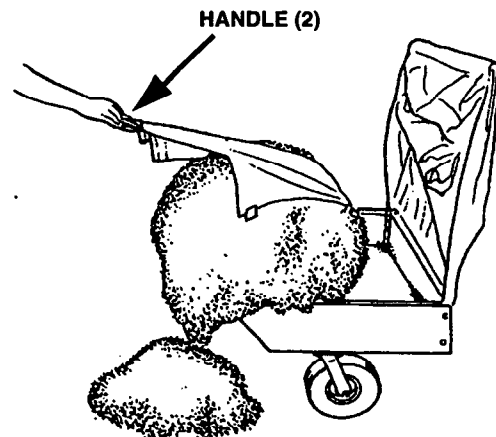
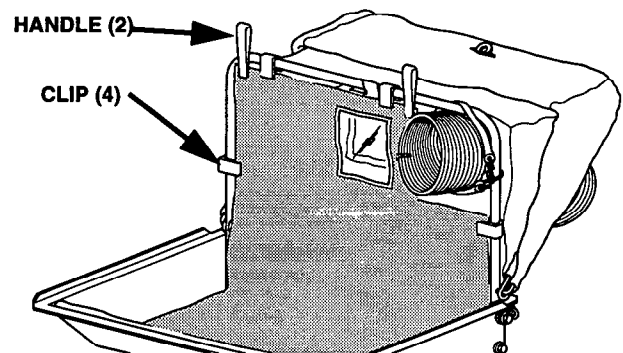

TIPPING THE CART BED:

1. Disconnect the middle chute (with the inspection window) from the lower chute.
2. Move the latch handle down to unlock the bagger cart bed. Grasp one of the lift handles, then tip the cart bed to dump the clippings.

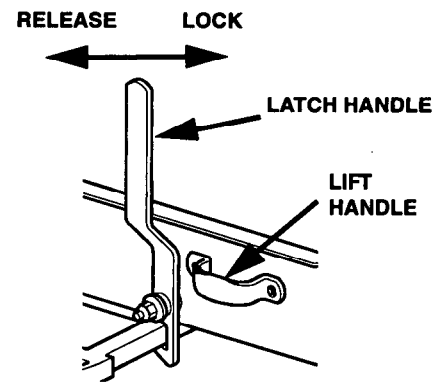
**USE AS A UTILITY CART**

The bagger cart can also serve as a light-duty utility cart for your tractor. For many applications, all you need do is roll up the cover and fasten it to the grommet strap (page 8). If the cover and / or dump cloth are in the way, refer to the *Assembly* section (page 17) and remove the cover and dump cloth as needed.

Using the Utility Cart

In general, follow the same operational guidelines for utility cart use as you would for the bagger cart.

- Make sure the load is secure and does not shift during use.
- Pay attention to the following weight and height limits, and never overload the utility cart.

MAXIMUM LOAD WEIGHT: 400 lbs. (181 kg)

MAXIMUM LOAD HEIGHT: 48 inches (1.2 m)

THE IMPORTANCE OF MAINTENANCE

Good maintenance is essential for safe, economical, and trouble-free operation.

WARNING

Improper maintenance, or failure to correct a problem before operation, can cause a malfunction in which you can be seriously hurt or killed.

Always follow the inspection and maintenance recommendations and schedules in this operator's manual and the owner's manual included with the tractor.

To help you properly care for your bagger cart, the following pages include a maintenance schedule, routine inspection procedures, and simple maintenance procedures using basic hand tools. Other service tasks that are more difficult, or require special tools, are best handled by professionals and are normally performed by a Honda technician or other qualified mechanic.

The maintenance schedule applies to normal operating conditions; consult an authorized Honda servicing dealer for recommendations applicable to your individual needs and use.

MAINTENANCE SAFETY

Some of the most important safety precautions follow. However, we cannot warn you of every conceivable hazard that can arise in performing maintenance. Only you can decide whether or not you should perform a given task.

WARNING

Failure to properly follow maintenance instructions and precautions can cause you to be seriously hurt or killed.

Always follow the procedures and precautions in this operator's manual and the owner's manual included with the tractor.

Safety Precautions

- Make sure the engine is off, ignition key is removed, PTO control lever/knob is in the OFF position and all moving parts have stopped before you begin any maintenance or repairs. This will eliminate several potential hazards:
 - **Carbon monoxide poisoning from engine exhaust.**
Be sure there is adequate ventilation whenever you operate the engine.
 - **Burns from hot parts.**
Let the engine and exhaust system cool before touching.
 - **Injury from moving parts.**
Do not run the engine unless the instruction tells you to do so. Even then, keep your hands, fingers, and clothing away. Do not run the engine when any protective guard or shield is removed.
- Read the instructions before you begin, and make sure you have the tools and skills required.
- To reduce the possibility of fire or explosion, be careful when working around gasoline. Use only a nonflammable solvent, not gasoline, to clean parts. Keep cigarettes, sparks, and flames away from all fuel-related parts.

Remember that an authorized Honda servicing dealer knows your bagger cart best and is fully equipped to maintain and repair it.

To ensure the best quality and reliability, use only new, genuine Honda parts or their equivalents for repair and replacement.

Do not alter or modify the bagger cart. If you have any questions, contact your dealer.

MAINTENANCE

MAINTENANCE SCHEDULE

Use the following maintenance schedule and the maintenance schedule shown in the tractor owner's manual.

ITEM	ACTION	INTERVAL		
		Before each use	Every 25 hours	Notes
Cover assembly	Inspect	●		
Tires	Check pressure	●		
Wheels	Lubricate		●	NLGI #2 grease

Cover Assembly

- Check the condition of the cover before each use. If the cover is torn, worn or otherwise damaged, replace it before using the bagger cart.
- Make sure the cover is not clogged with dirt or debris. The cover must be able to vent air for the best possible performance. Dirt and debris can also cause mold and rot which will cause premature wear of the cover fabric.
- Clean the cover with a standard garden hose. Pull out the dump cloth, and wash it at the same time. Allow the cover and dump cloth to fully dry before use. A wet cover or dump cloth will clog quickly and promote mold and rot.
- The cover is subject to deterioration and wear under normal use and it will eventually need to be replaced. Replace the cover with a genuine Honda bagger cart cover or equivalent. The cover must meet ANSI Standard B71.1.

Tires

- Check the tire air pressure before each use.

TIRE AIR PRESSURE: 30 psi (207 kPa).

Wheels

- Lubricate the wheels every 25 hours of use. There are grease fittings on each axle and swivel. One or two pumps of grease is usually sufficient.

WHEEL AND SWIVEL GREASE: NLGI #2 GENERAL PURPOSE GREASE

THE IMPORTANCE OF ASSEMBLY

Proper assembly is essential to operator safety and the reliability of the machine. Any error or oversight made by the technician assembling and servicing a unit can easily result in faulty operation, damage to the machine, or injury to the operator.

WARNING

Improper assembly can cause an unsafe condition that can cause your customer or others to be seriously hurt or killed.

Follow the procedures and precautions in installation instructions and shop manuals carefully

Some of the most important safety precautions are given below. However, we cannot warn you of every conceivable hazard that can arise in performing this installation. Only you can decide whether or not you should perform a given task

WARNING

Failure to properly follow assembly instructions and precautions can cause you to be seriously hurt or killed.

Follow the procedures and precautions in this manual carefully.

IMPORTANT SAFETY PRECAUTIONS

- Make sure you have a clear understanding of all basic shop safety practices and that you are wearing appropriate clothing and safety equipment. When performing this assembly, be especially careful of the following:
 - Read the instructions before you begin and be sure you have the tools and skills required to perform the tasks safely.
- Make sure the engine is off before you begin any maintenance or repairs. This will help eliminate several potential hazards:
 - Carbon monoxide poisoning from engine exhaust.**
Be sure there is adequate ventilation whenever you run the engine.
 - Burns from hot parts.**
Let the engine and exhaust system cool before touching.
 - Injury from moving parts.**
Do not run the engine unless the instruction tells you to do so. Even then, keep your hands, fingers, and clothing away. Do not run the engine when any protective guard or shield is removed.
- To reduce the possibility of a fire or explosion, be careful when working around gasoline or batteries. Use only a nonflammable solvent, not gasoline, to clean parts. Keep all cigarettes, sparks, and flames away from the battery and all fuel-related parts.

ASSEMBLY

REQUIREMENTS

A separate mounting kit is required to install this bagger cart. Some tractor models also require a side blower kit too. **DEALER:** Order other required kits from Honda Dealer Services:

Tractor model	Requirements	Honda Code
HA4118H38A	MKC4138A mounting kit	612400
HA4120H48A	MKC4148A mounting kit / BK4148A side-blower kit	612300 / 609800
other Honda models	See your Honda lawn tractor dealer for details.	



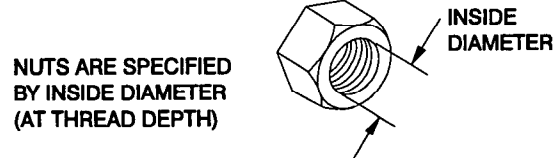
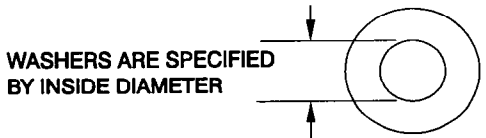
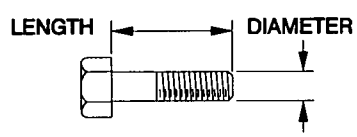
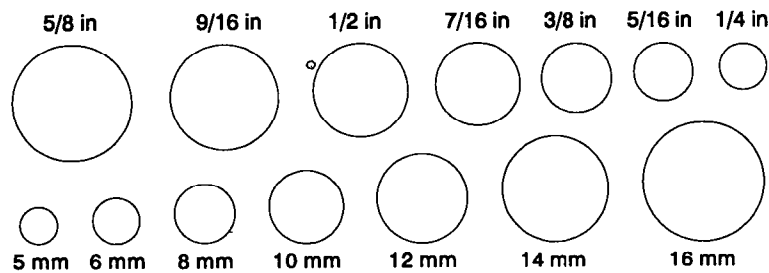
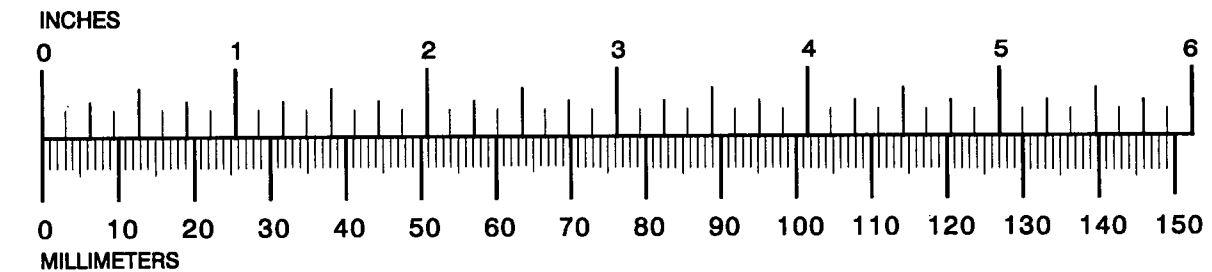

TORQUE VALUES

NUT AND BOLT DIAMETER	TORQUE VALUES		
	ft-lb	kg-m	N•m
8 mm bolts	15	2.1	21
1/4-inch nuts and bolts	7	1.0	10
5/16-inch nuts and bolts	14	1.9	19
3/8-inch nuts and bolts	25	3.5	34
1/2-inch nuts and bolts	60	8.3	81



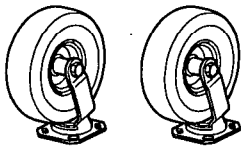
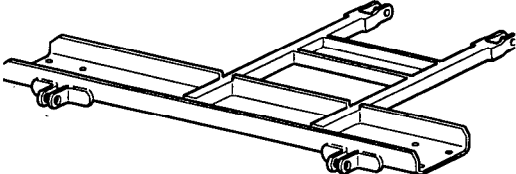
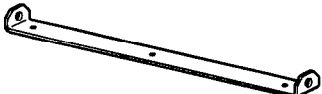
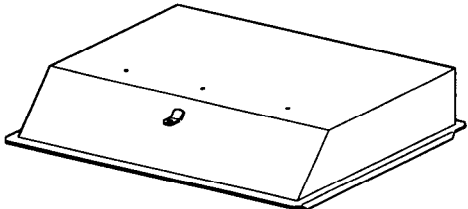

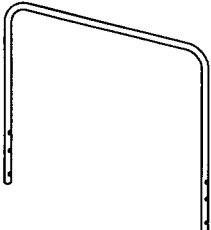
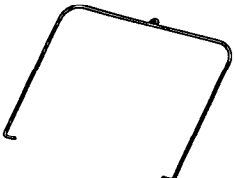

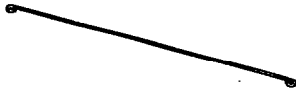
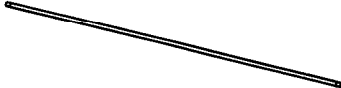



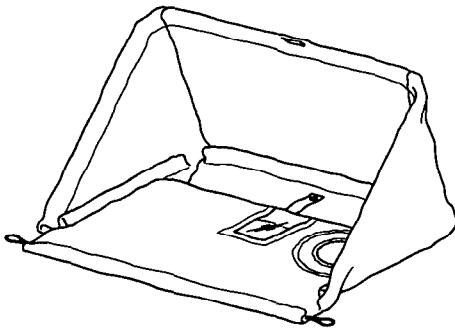
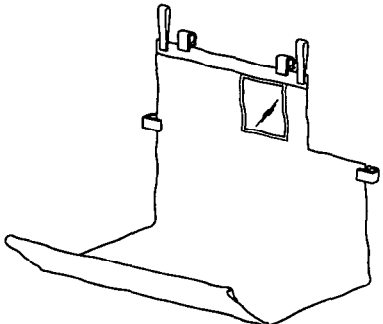







HARDWARE MEASURING CHART

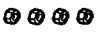

PARTS LIST

	Description	Qty.	Part Number
	Wheel assembly	2	81751-758-S61
	Frame	1	81741-758-S61
	U-bracket	1	81743-758-S61
	Cart bed	1	81711-758-S61
	Latch handle	1	81716-758-S61
	Lift handle	2	81718-758-S61
	Support tube	1	81721-758-S61
	Frame rod	1	81722-758-S61
	Support rod	1	81722-758-S61
	Straight rod	1	81724-758-S61
	Dump cloth rod	1	81734-758-S61

ASSEMBLY

	Cover	1	81726-758-S61
	Dump cloth	1	81731-758-S61
	Two-hook rubber strap	1	81246-758-S61
	Self-locking hex nut 3/8"-16	8	*
	Flat washer, 3/8"	10	*
	Hex nut, 5/16"	3	*
	Lock washer, 5/16"	3	*
	Hex bolt, 1/2"-13 x 1-1/4"	2	*
	Self-locking hex nut, 1/2"-13	2	*
	Hex bolt, 5/16"-18 x 1-1/4"	1	*
	Spring washer, 5/16"	2	90501-758-S61
	Flat washer, 5/16"	10	*
	Self-locking nut, 5/16"-18	1	*
	Hex nut, 1/4"-20	4	*
	Lock washer, 1/4"	4	*
	Self-locking nut, 5/16"-18	4	*
	Plastic spacer	2	*
	Hex bolt, 5/16"-18 x 1-1/2"	4	*
	Circle clip, 1-1/8"	4	90654-758-S61

* commercially available

ASSEMBLY

1. Install the wheel assemblies on the frame, using eight 3/8 x 1-inch hex bolts, eight 3/8 inch lock washers, and eight 3/8-inch lock nuts. Take care not to let the washers pinch the pivot seal on the wheel assembly. Torque the lock nuts to 15 ft-lb (3.5 kg-m, 34 N•m).
2. Apply grease to the grease fittings on the axles and swivels.

GREASE: NLGI #2 multi-purpose grease.

3. Inflate the tires
TIRE PRESSURE: 30 psi (207 kPa)

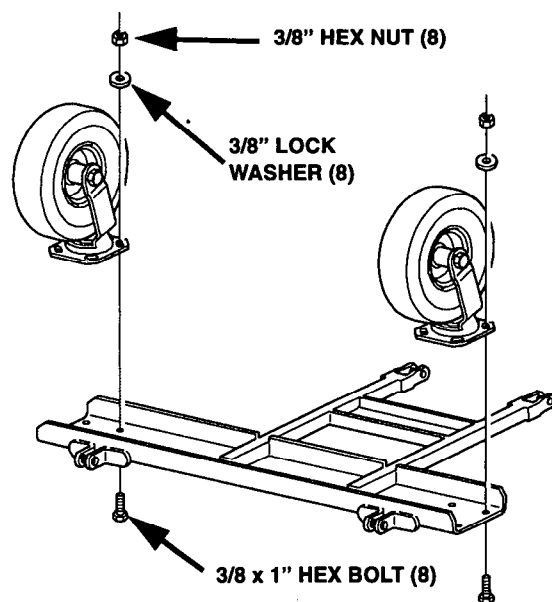

4. Install the U-bracket on the cart bed, using three 5/16 x 3/4-inch pan-head screws, three 5/16-inch flat washers, three 5/16 lock washers, and three 5/16 self-locking nuts. Torque the lock nuts to 14 ft-lb (1.9 kg-m, 19 N•m).

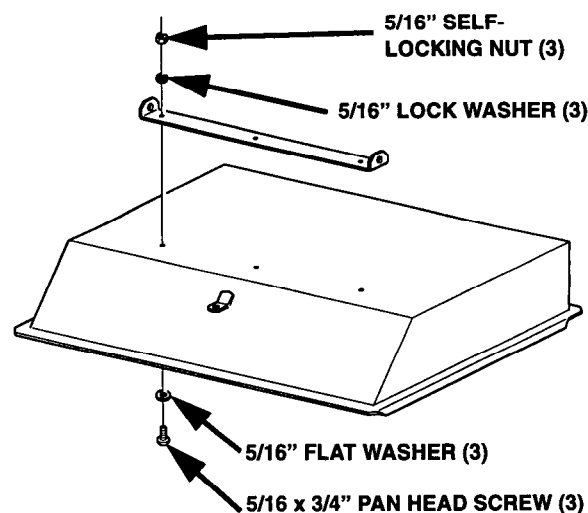

5. Turn the cart bed upside down. Install the frame on the U-bracket, using two 1/2 x 1-1/4-inch hex bolts and two 1/2-inch lock nuts. Torque the lock nuts to 60 ft-lb (8.3 kg-m, 81 N•m).

NOTICE

Overtightening the 1/2-inch lock nuts will bend the frame brackets.

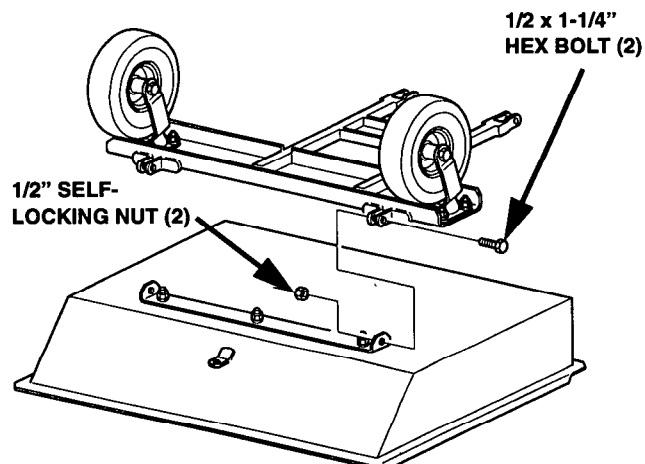

ASSEMBLY

6. Turn the cart bed right side up. Install the latch handle, using a 5/16 x 1-1/4-inch hex bolt, two 5/16 inch friction washers, two 5/16 inch flat washers, and a 5/16 inch self-locking nut (nylon insert).

When installing the hardware, position the friction washers with the cupped side toward the latch handle. Torque the self-locking nut enough so the latch handle will turn easily, but not move when released.

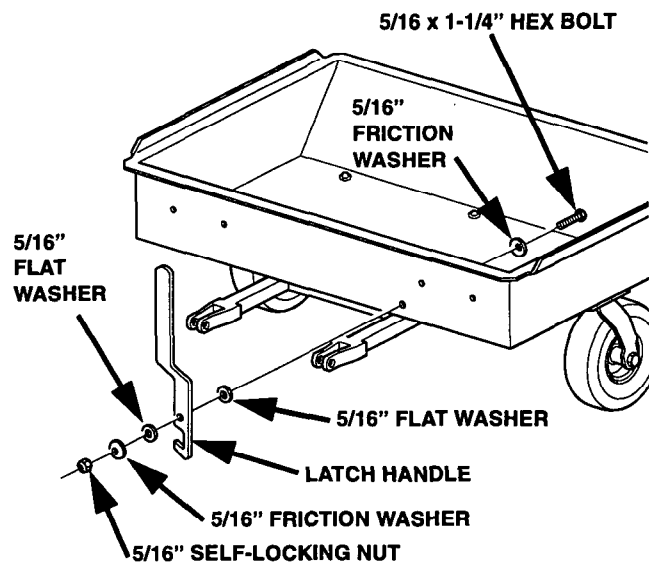

7. Install the lift handles using four 1/4 x 1/2-inch pan-head screws, four 1/4-inch lock washers, and four 1/4 inch nuts. Torque the lock nuts to 7 ft-lb (1.0 kg-m, 10 N•m).

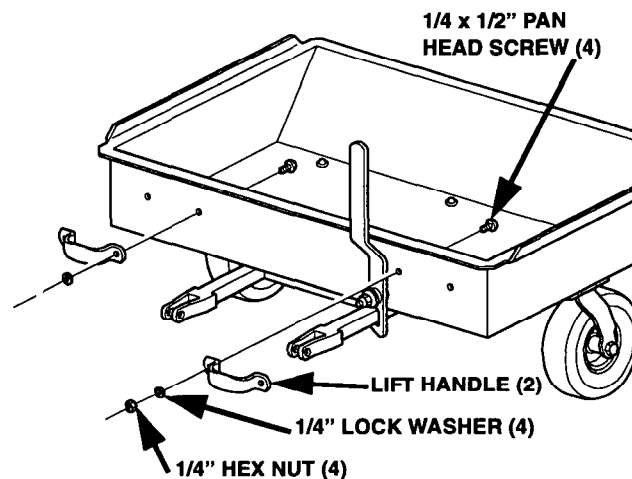

8. Install the support tube, using four 5/16 x 1-1/2-inch hex bolts, four 5/16-inch flat washers, two 5/16-inch plastic spacers, and four 5/16-inch lock nuts. Be sure the plastic spacers are installed on the top bolts only. Torque the lock nuts to 14 ft-lb (1.9 kg-m, 19 N•m).

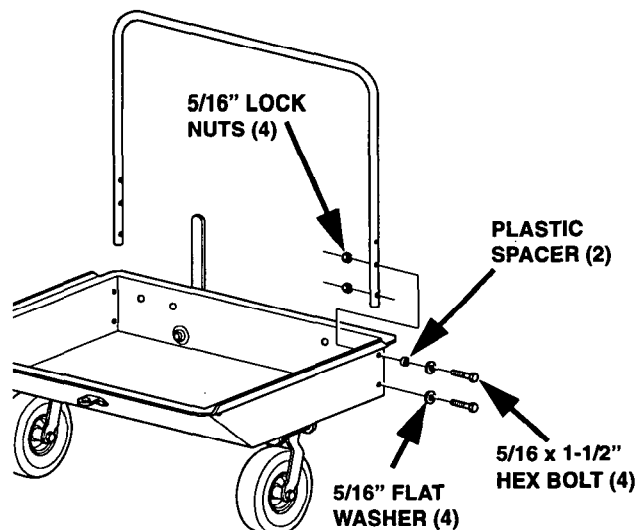

9. Thread the three rods through the cover as shown. It is easiest to install the frame rod first. When you do, make sure it is with the welded washer facing as shown.

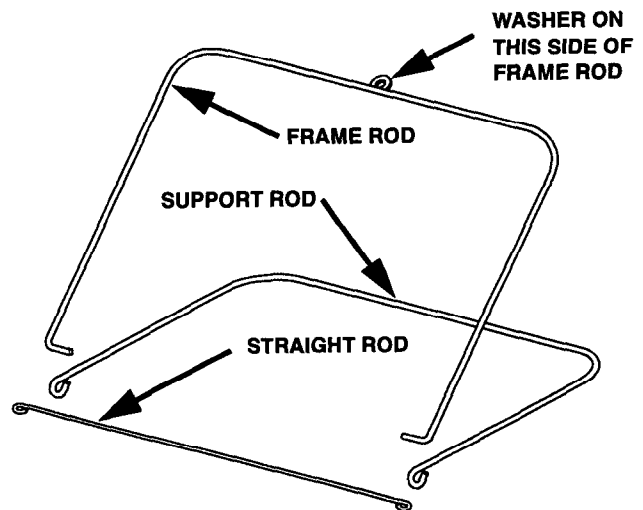

10. Hook the ends of the frame rod through the eyes in the ends of the support rod.

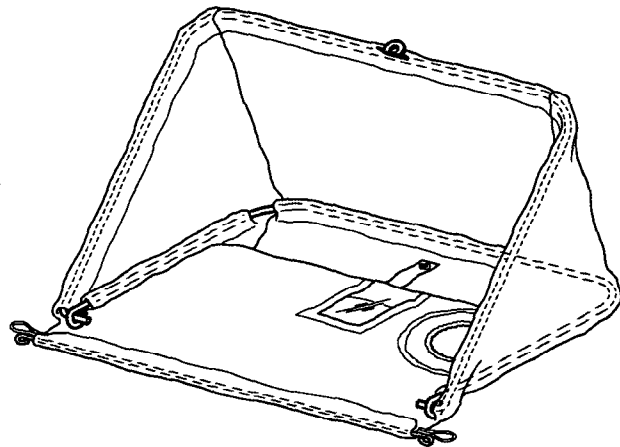

11. Insert the ends of the cover's frame rod through the holes in the cart's support tube.

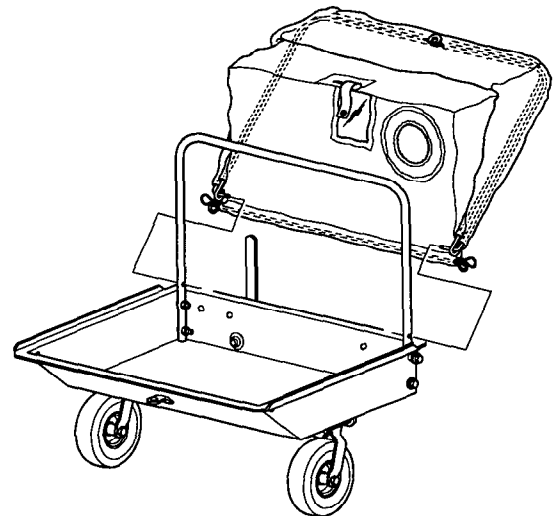

ASSEMBLY

12. Secure each end of the frame rod with a 3/8-inch flat washer and circle clip.
13. Attach the cover to the top of the support tube, using the grommet strap that is located next to the plastic window. Pull the strap over the top of the support tube, around and under the support tube, then through the slot in the front of the cover.
14. Attach the cover to the front corners of the cart by pulling the elastic loops through the eyes of the straight rod and hooking the loops over the cart bolts and onto the plastic spacers.

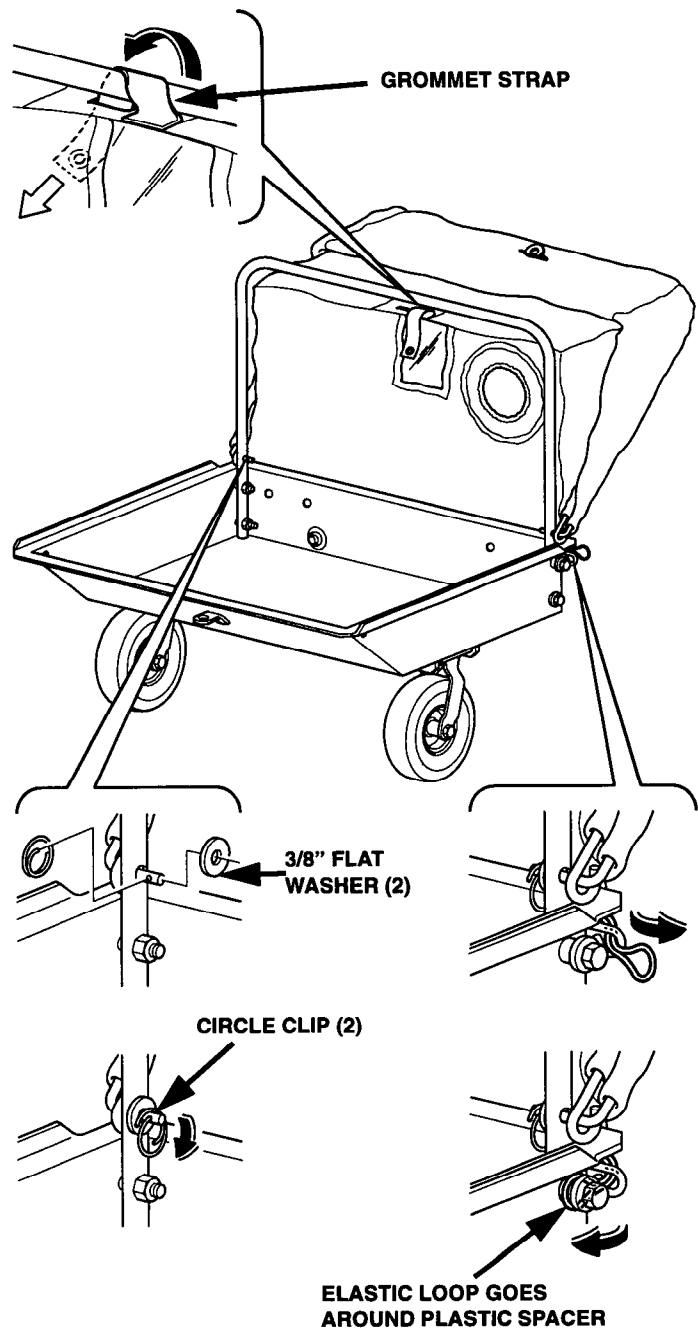

15. At this point, you need to install the upper flex tube supplied with the hitch kit for your tractor model. Push the flex tube through the gathered opening in the cover. There should be about 12-14 ribs in the flex tube pushed through the opening. Pay attention to the inspection window on the center section of the tube, so it remains facing the tractor operator.

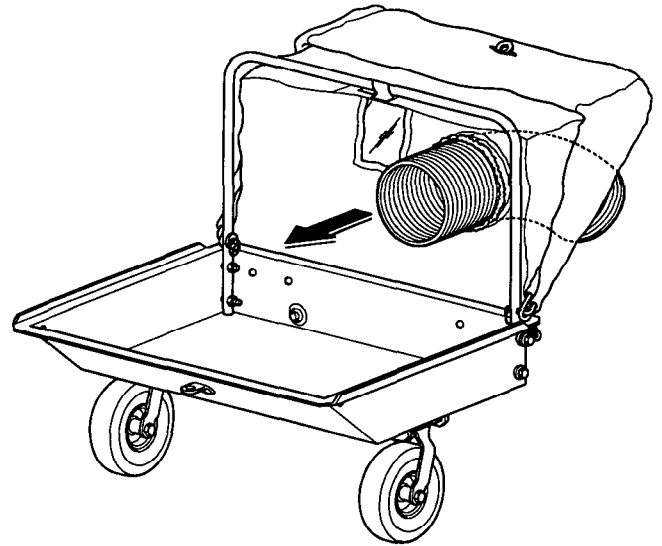

16. Raise the cover and tube up toward the frame. Install the rubber strap and S-hook as shown. the S-hook bends the flex tube slightly toward the cart's center, ensuring the clippings are evenly distributed.

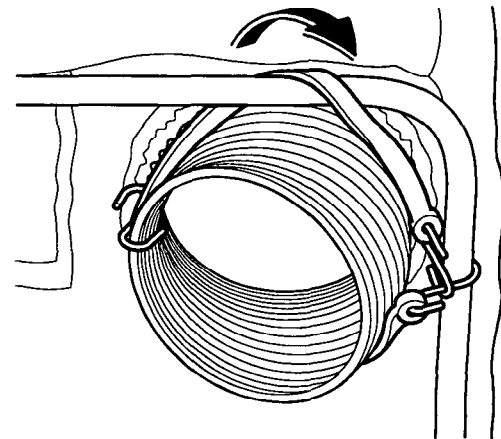
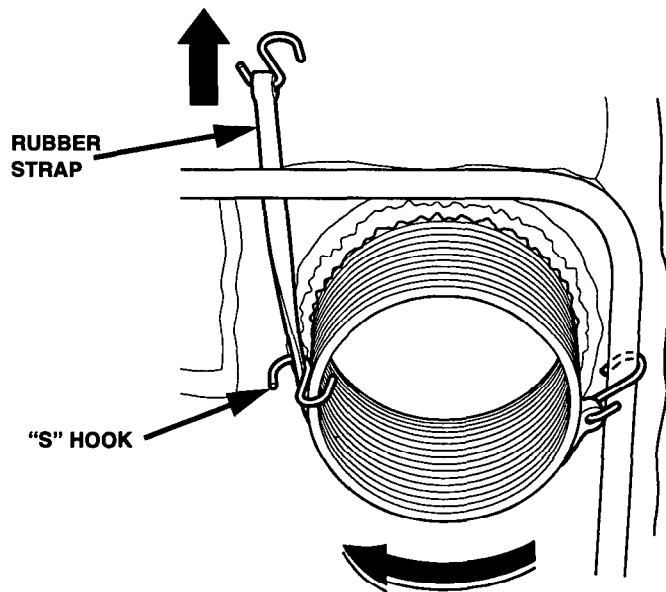

ASSEMBLY

17. Position the dump cloth with the flex tube cut-out at the right side of the cart. Thread the dump cloth rod through the cart, dump cloth sleeve and out the other side of the cart as shown. Secure each end of the rod by installing a circle clip outside of the cart bed.
18. Spread out the dump cloth in the cart bed, and hook the four plastic clips onto the support tube.

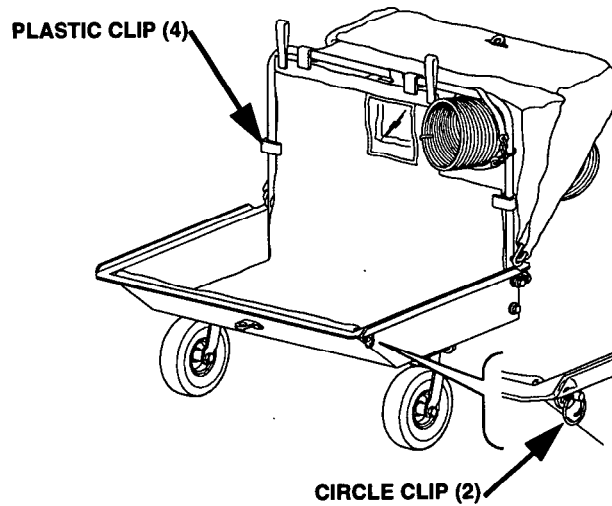
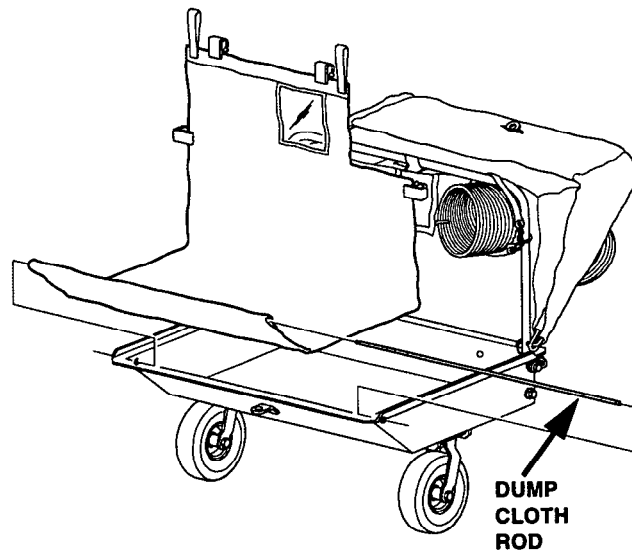

19. Install the rubber strap on the washer at the center of the cover frame rod. The open end of the hook must face the cart bed. Secure the upper hook to the frame rod by closing the hook loop with pliers. To hold the cover closed, hook the lower end to the cart bed as shown.
20. Install the HTA/Honda Power Equipment decal on the left side of the cart.

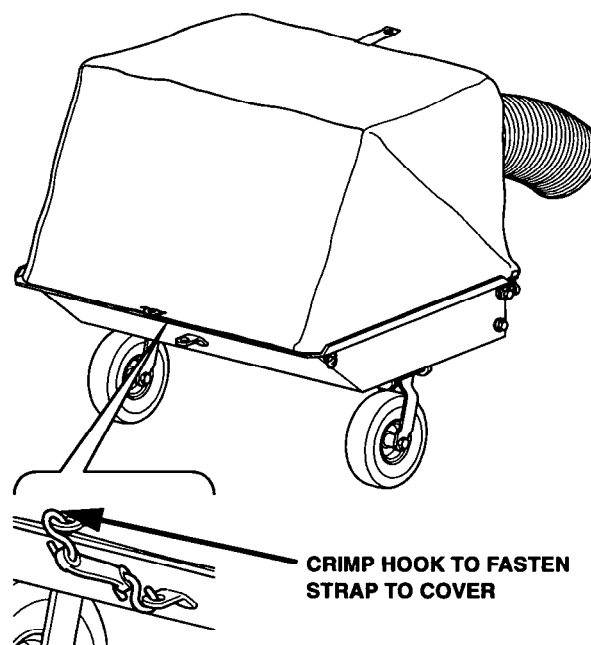

Continue Installation

To finish installing the bagger cart, follow the Installation Instructions supplied with the appropriate MKC-series kit (and side blower for 48-inch decks) for your tractor.

TRANSPORTING

Should you need to transport the bagger cart, remove the cover assembly if the cart is put on an open trailer or truck bed. The cover may blow off the cart or be damaged at highway speeds.

Use at least four tie-down straps to secure the cart to the transport vehicle. Do not connect straps to the cart bed, but use the frame, wheels and hitch instead.

STORAGE

Thoroughly clean and dry the entire bagger cart before storage. Dirt, clippings and other debris can trap moisture and promote rusting.

Sand away any rust spots and apply some touch-up paint to prevent additional rusting.

Verify the tires are fully inflated, and the wheels and swivels have been lubricated.

Pay close attention to the cover and dump cloth. Be sure they are completely clean and dry, or they may decay and mildew when stored.

Avoid storing the cover or dump cloth in direct sunlight, which can cause the fabric to wear prematurely.

Store the bagger cart in a dry location. Do not cover the bagger cart with a plastic sheet or other material than can trap moisture. This will promote rust.

SPECIFICATIONS

Dimensions		
Length	41 inches (1,041 mm)	
Width	46 inches (1,168 mm)	
Height	cover closed cover opened cart only	41.5 inches (1,054 mm) 51 inches (1,295 mm) 20 inches (508 mm)
Cart bed interior	length at top edge length at bottom edge width height	31 inches (787 mm) 24 inches (610 mm) 43.5 inches (1,105 mm) 7 inches (178 mm)
Capacities		
Clipping capacity (approximate)	17 bushels (600 liters)	
Cart bed interior volume	4.8 cubic feet (136 liters)	
Maximum cart bed weight capacity	400 pounds. (181 kilograms)	
Maximum load height	48 inches (1.2 meters)	
Other Specifications		
Tire size	4.10/3.50-4 (2 PR)	
Tire pressure	30 psi (207 kPa)	
Wheel and swivel grease	NGLI #2, general purpose grease	

PARTS

PARTS

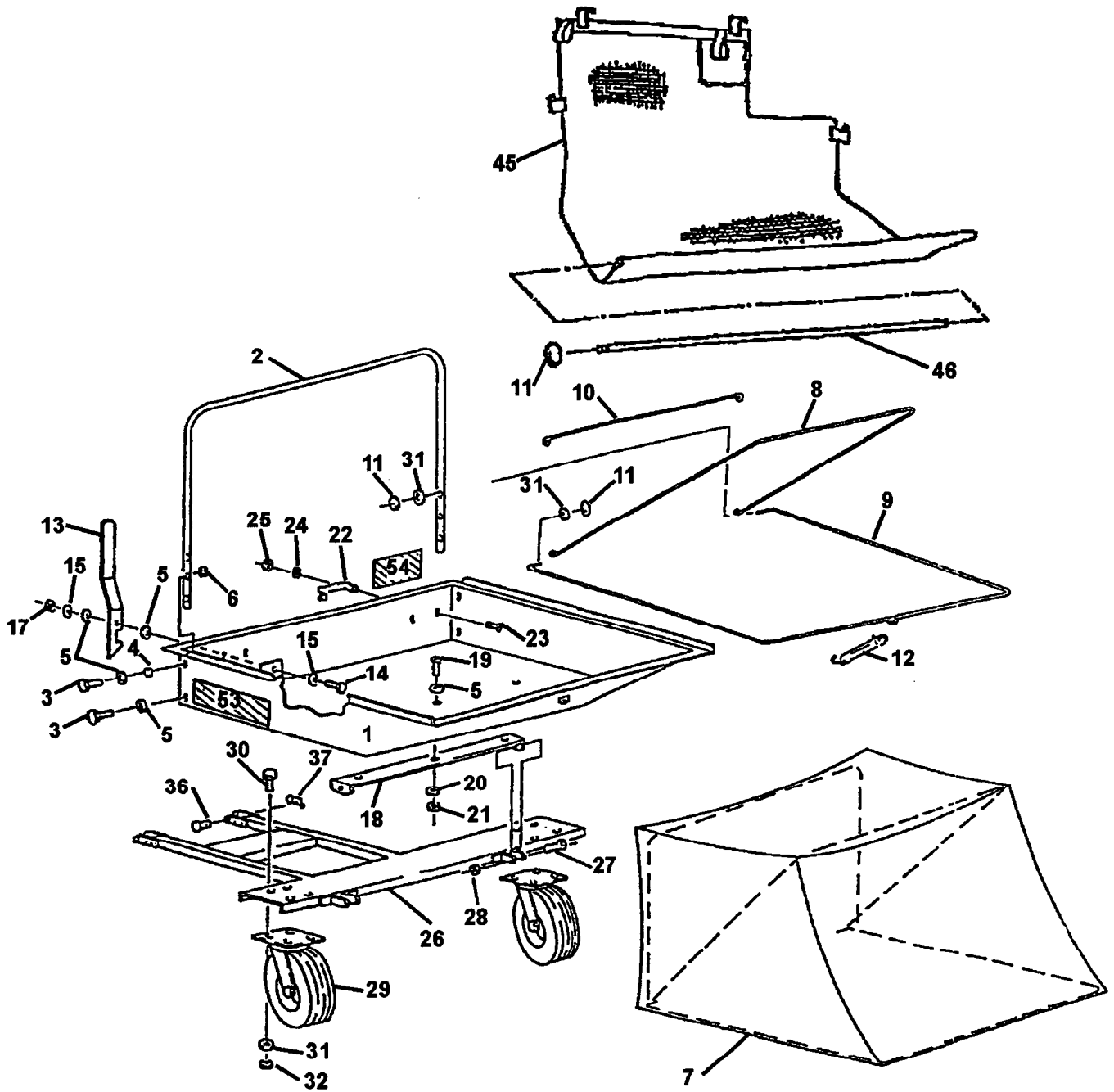

Ref	Description	Qty	Part number
1	BED, CART	1	81711-758-S61
2	TUBE, SUPPORT	1	81721-758-S61
3	BOLT, HEX 5/16 x 1-1/2"	4	*
4	SPACER, PLASTIC, 5/16"	2	
5	WASHER, FLAT, 5/16"	10	
6	NUT, LOCK, 5/16"-18	4	
7	COVER	1	81726-758-S61
8	ROD, SUPPORT	1	81722-758-S61
9	ROD, FRAME	1	81723-758-S61
10	ROD, STRAIGHT	1	81724-758-S61
11	CLIP, CIRCLE, 1-1/8"	4	90654-758-S61
12	STRAP, RUBBER (TWO HOOKS)	1	81246-758-S61
13	HANDLE, LATCH	1	81716-758-S61
14	BOLT, HEX, 5/16"-18 x 1-1/4"	1	*
15	WASHER, SPRING, 5/16"	3	90501-758-S61
16	NUT, NYLON INSERT LOCK 5/16"	1	*
17	U BRACKET	1	81743-758-S61
18	SCREW, PAN HEAD, 5/16"-18 x 3/4"	5	*
19	WASHER, LOCK, 5/16"	3	*
20	NUT, HEX, 5/16"-18	3	*
21	HANDLE, LIFT	2	81718-758-S61
22	SCREW, PAN HEAD, 1/4"-20 x 1/2"	4	*
23	WASHER, LOCK, 1/4"	4	*
24	NUT, HEX, 1/4"-20	4	*
25	FRAME	1	81741-758-S61
26	BOLT, HEX, 1/2"-13 x 1-1/4"	2	*
27	NUT, HEX LOCK, 1/2"-13	2	*
28	WHEEL, SWIVEL	4	81751-758-S61
29	BOLT, HEX, 3/8"-16	8	*
30	WASHER, FLAT 3/8"	10	*
31	NUT, HEX LOCK 3/8"-16	8	*
36	CLEVIS PIN	2	90751-758-S61
37	SPRING CLIP	2	90655-758-S61
45	DUMP CLOTH	1	81731-758-S61
46	ROD, DUMP CLOTH	1	81734-758-S61
53	DECAL, CAPACITY	1	87521-758-S61
54	DECAL, HTA	1	87520-758-S60

* commercially available

ADDITIONAL INFORMATION

HONDA PUBLICATIONS

An owner's manual, shop manual and parts listing are available for your tractor. Contact your authorized servicing Honda tractor dealer to order any of these publications.

WARRANTY SERVICE INFORMATION

Honda Power Equipment dealership personnel are trained professionals. They should be able to answer any question you may have. If you encounter a problem that your dealer does not solve to your satisfaction, please discuss it with the dealership's management. The Service Manager or General Manager can help. Almost all problems are solved in this way.

If you are dissatisfied with the decision made by the dealership's management, contact the Honda Power Equipment Customer Relations Office.

You can write to:

American Honda Motor Co., Inc.
Power Equipment Division
Customer Relations Office
4475 River Green Parkway
Duluth, GA 30096-2565

Or telephone:

(770) 497-6400 weekdays, 8:30 a.m. - 5:00 p.m. EST

When you call or write, please provide us the following information:

- Model and serial numbers (bagger cart and power unit)
- Name of the dealer who sold you the bagger cart
- Name and address of the dealer who services your bagger cart or midsize commercial mower
- Date of purchase
- Your name, address, and telephone number
- A detailed description of the problem

HONDA

PN: 31BC1600
HC: 6076368



Printed on
Recycled Paper