



User Manual

SCOIATTOLO 75 - 85



ATTENTION! PLEASE READ THIS MANUAL BEFORE USING THE MACHINE

**FIorentINI INDUSTRIALE S.r.l.
INDUSTRIAL CLEANING MACHINES**



INDEX

MACHINE DELIVERY	page 2
INTRODUCTION	2
TECHNICAL DESCRIPTION	3
GENERAL INFORMATION	4
MANUFACTURER RESPONSIBILITY	4
INTERVENTION REQUEST	4
TRANSPORT AND STOCKING	5
PACKED MACHINE HANDLING	5
UNPACKING THE MACHINE	5
UNPACKED MACHINE HANDLING	5
DESCRIPTION	6
DASHBOARD	6
SYMBOLS ON THE DASHBOARD	7
USING THE MACHINE	8
Safety Systems	8
Brake	9
Batteries Installation	9
Battery Charger Installation	10
Choosing the detergent	10
Starting and Preparing the Machine	10
Use of the machine	10
Detergent quantity	11
Water unload	11
Squeegee Adjustment	12
Brushes Replacement	13
Cleaned area width regulation	14
SAFETY, MAINTENANCE AND CONTROLS	15
GENERAL SEFATY RULES	15
DAILY MAINTENANCE RULES	16
Maintenance Plan	16
Batteries	17
Squeegee Blades Replacement	18
Suction Motor Maintenance	19
CONTROLS	20
Checking the Safety System	20
Checking the Electric System	20
Checking the Braking System	20
SUMMARY	21



MACHINE DELIVERY

AS SOON AS THE MACHINE IS DELIVERED, PLEASE CHECK THAT THERE IS NOT ANY DAMAGE DUE TO TRANSPORT.

IN CASE OF DAMAGE OR MISSING PARTS, PLEASE ADVISE IMMEDIATELY THE MANUFACTURER.

INTRODUCTION

THIS KIND OF SCRUBBER MACHINE CAN PERFECTLY WASH EVERY KIND OF FLOOR FROM EVERY KIND OF DIRT WITH AN EXCELLENT RESULT.

THIS IS WHY THE MACHINE MUST ALWAYS BE USED IN A CORRECT WAY AND MAINTAIN IT. PLEASE, READ CAREFULLY THIS USER AND MAINTAINANCE MANUAL.

THE MACHINE MUST ONLY BE USED FOR THE INDUSTRIAL CLEANING.

Pease, keep this manual for any future reference



TECHNICAL DESCRIPTION

DIMENSIONS	SCOIATTOLO 75	SCOIATTOLO 85
LENGHT	1360 mm	1360 mm
WIDTH	860 mm (with brushes protection)	860 mm (with brushes protection)
HEIGHT	1360 mm	1360 mm
WASHING BRUSHES	2	2
WASHING BRUSHES DIMENSIONS	Ø 380 mm	Ø 410 mm
CLEANED AREA WIDTH	750 mm	850 mm
SQUEEGEE WIDTH	950 mm	1050 mm
POLYETHYLENE SOLUTION TANK	160 lt.	
POLYETHYLENE RECOVERY TANK	155 lt.	
FRONT WHEEL DIAMETER	250 mm.	
REAR WHEEL DIAMETER	310 mm.	
TRACTION	electric	
WEIGHT WITHOUT OPERATOR ON BOARD		
WEIGHT WITHOUT BATTERIES	250 kg.	250 kg.
BATTERIES ROOM (LxWxH)	590x530x325 mm.	
ELECTRIC CHARACTERISTICS		
ENERGY SOURCE	Nr. 6 batteries (6V)	
VOLTAGE	36 V	
WASHING BRUSHES ENGINE	1000W 32A 2200rpm	
TRACTION DRIVING WHEEL	600w 21A 130rpm	
SUCTION ENGINE	850w 23A 16000rpm	
FUNCTIONS		
DRIVE	Operator on board	Operator on board
U-TURN LANE	2500 mm	
SQUEEGEE UP	electrical	
SQUEEGEE DOWN	mechanical by pedal	
SERVICE BRAKE	mechanical by pedal	
PARKING BRAKE	mechanical by pedal	
PERFORMANCES		
FORWARD SPEED	0 ÷6 Km/h	
BACKWARD SPEED	0 ÷4 Km/h	
MAXIMUM OVERCOMING SLOPE	10 %	
MAXIMUM OVERCOMING SLOPE FOR A U-TURN	5% A 1 Km/h	
CLEANED AREA (m ² /h)	4300 m ² /h	4700 m ² /h
ECOLOGICAL CHARACTERISTICS		
NOISE AT OPERATOR'S EAR	< 70 dB(A)	
NOISE AT OPERATOR'S SEAT	< 2.5 m/s ²	



GENERAL INFORMATION

MANUFACTURER RESPONSIBILITY

The manufacturer FIORENTINI is not responsible for any damage due to the no-acquaintance or no-fulfilment of the instructions of this manual. The same applies to changes, modifications, and/or the installation of accessories not authorized by FIORENTINI.

In particular, FIORENTINI is not responsible for any damage caused by:

- Natural calamity
- Erroneous manoeuvres
- No maintenance

Furthermore, the manufacturer is not responsible for any intervention not performed by FIORENTINI technicians except for ordinary maintenance.

INTERVENTION REQUEST

Intervention should be made after a careful analysis of the damage and its causes. In any case, when a damage occurs, it is necessary to give the following information to the authorized Service Centre:

- ?? Machine model;
- ?? Serial number (picture nr. 1);
- ?? A detailed description of the damage;
- ?? Check done;
- ?? Performed adjustments and their results;
- ?? Any other information considered useful for this purpose;
- ?? Customer address.

Fig. 1



FIORENTINI	MADE	CE
S.r.l.	IN	
	ITALY	
Mod. SCOIATT-80M	S.N.SCO-04-005	2004
V 36	Hz.	
Kg 480	A 70	W 2650



TRANSPORT AND STOCKING

PACKED MACHINE HANDLING

The machine is delivered in a special package, which is shown in picture nr. 2. The gravity centre is indicated on the package with a black arrow. The pallet must be forked in the middle of the side with the black arrow in order to avoid overturning. The case should be handled with extreme caution. It is forbidden to lay cases on each other.

Picture 2

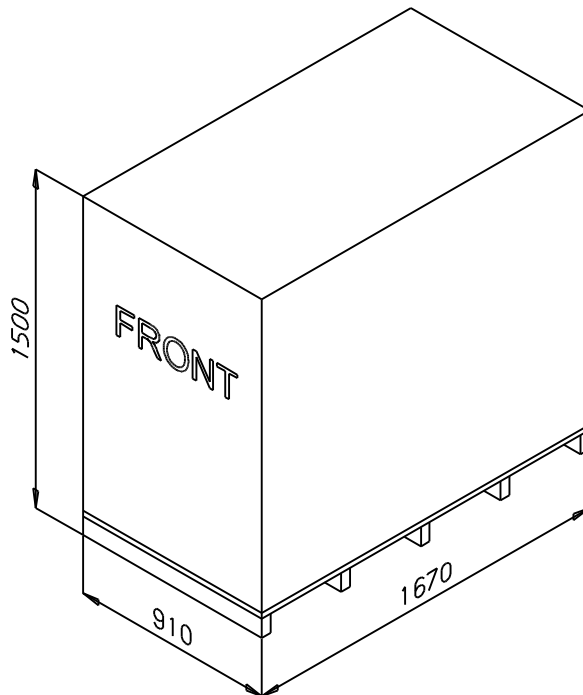

UNPACKING THE MACHINE

1. Cut the plastic bands. Pay attention to the spring back.
2. Remove the clips that fix the carton to the pallet.
3. If the case is made of plywood, remove the clips from the each side and the base.
4. Remove the plastic bands that hold the machine.
5. Place the machine on the floor.

UNPACKED MACHINE HANDLING

1. Check the machine and install the batteries if they are not installed.
2. If the machine has to be handled for a short transport, disconnect the battery cables. It is recommended to pack the machine again in its original case if it has to be handled for a longer transport.





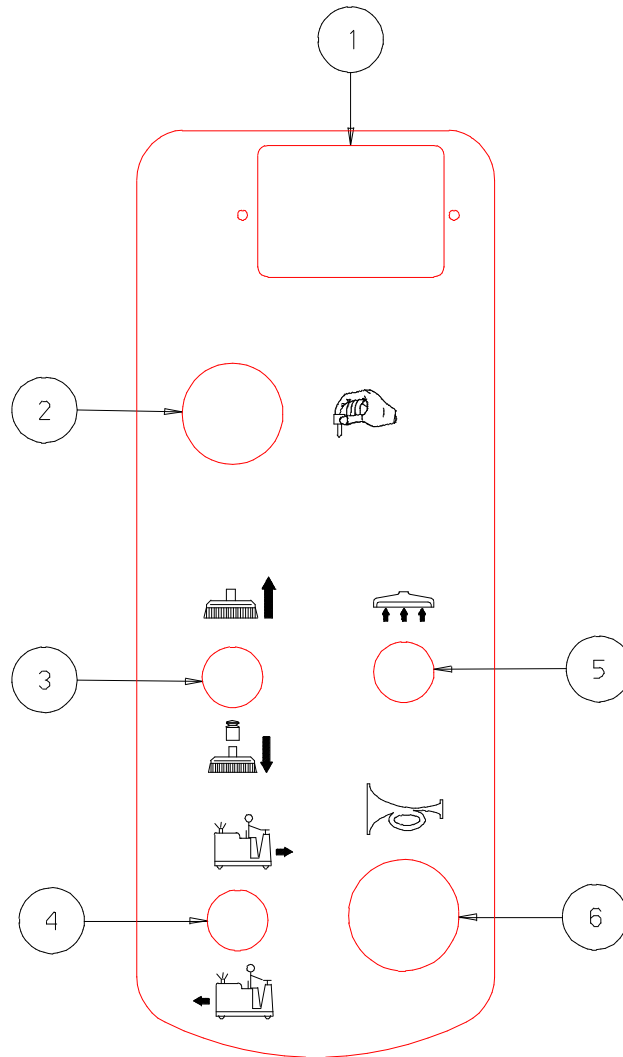

DESCRIPTION

DASHBOARD

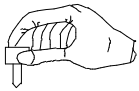

1	BATTERY CHARGER INDICATOR
2	KEY SWITCH
3	BRUSHES SWITCH
4	FORWARD/BACKWARD GEAR SELECTOR
5	SUCTION SWITCH
6	HORN

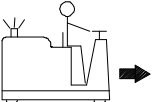
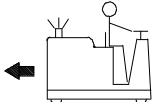
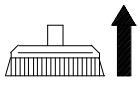
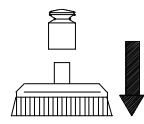
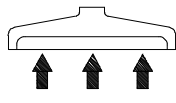
SYMBOLS ON THE DASHBOARD

0	Off	1	On
	Main switch		Horn
	Forward gear		Backward gear
	Washing brushes off		Washing brushes on
	Suction on		Suction off



USING THE MACHINE

SAFETY SYSTEMS

The machine is equipped with some safety systems.

Outlet (picture 3), it is the same used for the battery charger. In case of emergency, the operator must take the plug out of the outlet by means of its handle (picture 4).

Before using the machine, the operator must know how the safety system of the machine works. It is forbidden to plug in, if the problem has not been sorted completely out. If necessary, ask for a trained technician.

Float: the recovery tank is equipped with a float that stops the machine if the tank is too full. In this case, before restarting the machine the operator has to empty the recovery tank (see page 11). When the machine stops because the recovery tank is full, the battery charger indicator on the dashboard blinks six times.

Insufficient battery charge: The electronic card, that controls every function of the scrubber machine, is equipped with a safety system that stops all the machine functions (except for the traction) when the batteries autonomy is lower than 20%. In this way, the batteries lifetime lasts longer.



Picture 3



Picture 4

BRAKE

The machine is equipped with parking and service brake (picture 5).

- ?? The service brake is operated by the pedal placed on the right of the footboard (picture 1).
- ?? The parking brake is operated by means of the service brake pedal. The operator has to push this pedal completely down and do the opposite when he/she wants to release it.

STEERING WHEEL ADJUSTMENT

The machine steering wheel can be adjusted so that the operator can reach a proper position (picture 5).

- ?? In order to adjust the steering wheel position, the operator has to unscrew the knob placed on the left of the steering column. Then the operator has to move the steering wheel forward and backward until the best position is found. Finally, the operator has to screw the knob again in order to fix the steering wheel.

Picture 5

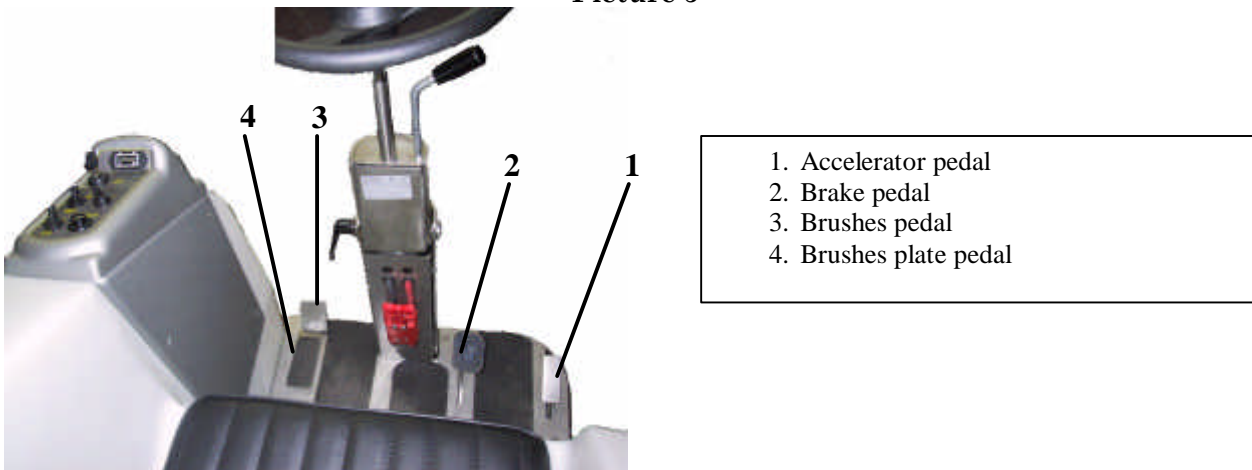

BATTERIES INSTALLATION

- ?? Pull the solution tank up in order to reach the batteries room;
- ?? Install the batteries in its room as shown in picture nr. 6 making sure that there are not any breaks or holes in the batteries boxes;
- ?? Never add distilled water after the batteries recharge;
- ?? Always clean the surfaces that are in contact with the connections;
- ?? Thanks to handles batteries handling is easier.



Picture 6



BATTERY CHARGER INSTALLATION

- ?? Install the battery charger in a ventilated and dry place, far from heat sources and corrosive substances;
- ?? Protect the mains with a delayed switch or with a fuse whose load is higher than the maximum absorption of the battery charger .
- ?? Do not invert the polarities of the battery charger outlet.

CHOOSING THE DETERGENT

For a good floor cleaning, it is important to choose the right detergent solution. A too strong detergent can compromise the machine lifetime. It is necessary to use a controlled foam detergent, or an antifoaming additive, in order to avoid damaging the suction engine. Otherwise, the operator can use vinegar to avoid foam and pour 50cc of it in the recovery tank before scrubbing.

STARTING AND PREPARING THE MACHINE

If the machine is connected with the battery charger, the operator must firstly disconnect the battery charger plug from the batteries one and connect the batteries plug with the power supply plug (see picture 4). Secondly, the operator must fill water lifting the recovery tank up and turning the cap. Now the operator can seat on the machine, start it and wash the surface.

USE OF THE MACHINE

The operator, thanks to his/her experience, has to choose the right type of brush and detergent for the surfaces that has to be cleaned and to decide if the floor needs a second washing.

Follow these instructions for a correct washing:

1. press the brushes motor switch;
2. press the solution solenoid valve switch;
3. press the suction switch.

By means of the accelerator pedal the washing brushes and the suction motor are activated. On the contrary, both the washing brushes and the suction engine are disactivated after a few seconds if the operator leaves the accelerator pedal. Before the surface is completely dry, the operator must switch the solution solenoid valve off because this is not activated/disactivated by the accelerator pedal.

The operator has to do a second washing if the surface is particularly dirty:

1. wash the surface with the squeegee up and the brushes down;
2. activate the brushes;
3. press the solution solenoid valve switch;
4. leave the solution on the surface to dissolve the dirt;
5. do a second washing with brushes and squeegee down, the suction activated and the solution solenoid valve opened.

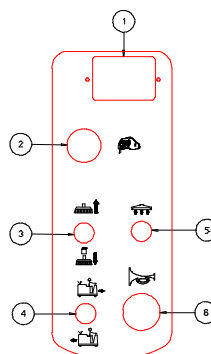

DETERGENT QUANTITY

During the cleaning the operator can control the detergent quantity by means of a cock, which is on the left of the machine frame.

Important: before checking the water quantity that flows to the brushes, make sure that the ignition key is not in the dashboard in order to avoid a casual starting of the machine.

Picture 7



1. water lever

WATER UNLOAD

The scrubber machine is equipped with two pipes for water discharge (pictures 8-a and 8-b):

If you need to discharge water from the tanks, you have to place the machine on a dump well, release the pipe of the tank and open the rubber cap at the end of the pipe itself.

Picture 8-a



Picture 8-b

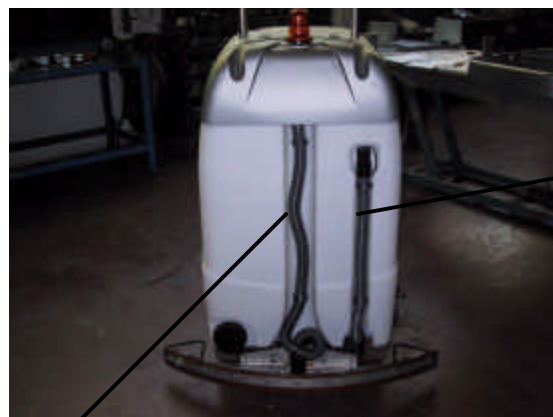

1. recovery tank discharge pipe
 2. suction squeegee pipe
 3. solution tank discharge pipe

SQUEEGEE ADJUSTMENT

The squeegee has to be well regulated in order to have a perfect dry system. This kind of squeegee can perfectly suck water, which flows into the suction pipe, but it must be parallel to the surface.

The operator has to follow the instructions below for the squeegee adjustment:

- ?? Replace the ignition key from the dashboard in order to avoid the casual starting of the machine.
- ?? By means of the knob (see detail nr. 1 in picture nr. 9) regulate the squeegee. The best squeegee pressure is reached when the corner of its blade is in contact with the floor and their inclination is between 45° and 60°.
- ?? Squeegee pressure regulation: the operator has to work on the squeegee driving wheels cam pins. The operator has to unloose the screw at the bottom of the pin by means of the spanner delivered with the machine. Afetrwards the operator has to tighten this screw again.

Picture 9

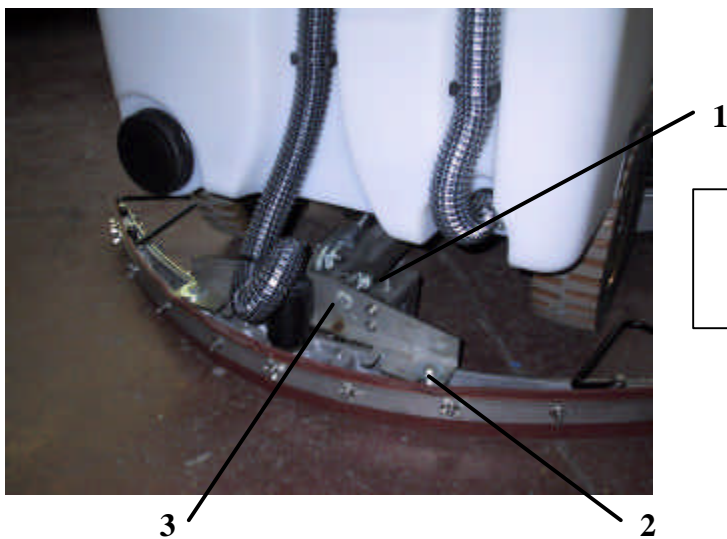

- | |
|--|
| <ol style="list-style-type: none">1. squeegee height screw2. squeegee fastening screw3. squeegee inclination screw |
|--|

BRUSHES REPLACEMENT

The operator has to follow the instructions below to replace the brushes (picture 10):

- ✂✂ Take the ignition key away from the dashboard in order to avoid a casual starting of the machine;
- ✂✂ Right side brush replacement: remove the case by means of the knob (see detail nr. 1 in picture nr. 10-a) and translate it outside. Translate counterclockwise the right brush and remove it;
- ✂✂ To set a new brush up: put the coupler pins under the brush support slots, pull the brush up and translate it (clockwise for the right brush and counterclockwise for the left one);
- ✂✂ Set again the brushes cases up and fix them by means of the knob.



1

Picture10-a



Picture 10-b

2

3

1. Protection brush knob
2. Brush
3. Brush protection



CLEANED AREA WIDTH REGULATION

Thanks to this scrubber machine, the cleaned area width can be regulated.

The operator can choose between 70 cm. or 80 cm., but only if the brushes, their protections and the propeller shaft of the reduction gear have been bought for both versions.

The operator has to follow the instructions listed below for machines with central brushes in order to regulate the cleaned area width.

- ?? Take the ignition key away from the dashboard in order to avoid a casual start of the machine;
- ?? Remove the brushes and the protection cases as shown in paragraph 'BRUSHES REPLACEMENT';
- ?? Remove the brushes plate and at the same time the hydraulic pipes and the electric cables;
- ?? Choose between the two brushes plate version and set up the right propeller shaft of the reductions gears;
- ?? Set the brushes plate up again, the hydraulic pipes and the electric cables;
- ?? Set the chosen brushes version up: Ø 380 brush for SCOIATTOLO 70 or Ø 410 brush for SCOIATTOLO 80;
- ?? Set the brushes protection cases up. They are the same for both versions.
- ?? Set the right squeegee up for the brush chosen version.



SAFETY, MAINTENANCE AND CONTROLS

GENERAL SAFETY RULES

The rules listed below must be carefully followed in order to avoid damages to the operator and/or the machine.

- ?? Read carefully the labels stucked on the machine and do not cover them for any reason;
- ?? Do not mix detergents of different kind in order to avoid the development of dangerous gases;
- ?? Do not use the machine in places with explosive substances;
- ?? Do not use the machine as a means of transport
- ?? Do not use acids which could damage the machine;
- ?? **Do not intake flammable liquids for any reason**
- ?? In case of fire, please use a powder extinguisher. Do not use water.
- ?? If the machine does not work in the correct way, please make sure that the defect is not caused by a lack of ordinary maintenance. On the contrary, please immediately contact FIORENTINI Service;
- ?? Before starting the machine again, please make sure that all fixed or removable protections are in their position;
- ?? Do not wash the machine with corrosive substances or with water jets;
- ?? Do not keep the machine in an environment with a temperature $< 3^{\circ} \text{C}$;
- ?? Avoid to leave the machine in a no-authorized place for the scrapping. In fact, the machine is made of materials that must be recycled and disposed in authorized centres;
- ?? The machine does not develop dangerous vibrations;
- ?? Keep always the machine far from kerbstones and drive slowly on surfaces with holes;
- ?? Make sure that there are no people near the machine during the cleaning;
- ?? Do not start the machine if it is under maintenance;
- ?? Do not drive too fast while turning, in particular on sloping surfaces;
- ?? **It is absolutely forbidden to touch the inferior side of the machine during the cleaning. If it is necessary, please keep the ignition key away from the dashboard;**
- ?? The operator must carefully read this manual and do not use alcohol or medicines before driving the machine;
- ?? **The machine cannot be used in places with dangerous substances and in particular with explosive atmospheres or with a bad microclimate;**
- ?? Please, disconnect the battery when the machine is not working.

Important: the operator has to have a sufficient knowledge of the Italian language.



Daily maintenance rules

While the operator is cleaning, maintaining the machine or replacing some of its parts, the ignition key must not be in dashboard.

MAINTENANCE PLAN

EVERY DAY

?? Clean the recovery tank and the suction engine filter

EVERY WEEK

?? Check if the squeegee pipes and the suction ones are clean

?? Check the squeegee rubber blades state

?? Check the water level of the batteries

EVERY MONTH

?? Check the filter of the solution tank

EVERY SIX MONTHS

?? Check the connection of the batterie cables

EVERY YEAR

?? Check the coal brushes of each engine

EVERY TWO YEARS

?? Check the safety devices

?? Check the electric system

BATTERIES

?? Keep the battery room open during the batteries recharge;

?? It is forbidden to use flames and/or to smoke near the batteries;

?? Pay attention to the battery acid;

?? Do not develop sparks near the batteries;

?? Pay attention to the batteries gazes, which can burst;

?? Do not invert battery polarities.

CHECKING THE BATTERY CHARGE

The operator has to check the batteries charge when the machine is on duty by means of the indicator on the dashboard, which shows:

?? Green light: charged battery

?? Yellow light: slightly charged battery

?? Red light: uncharged battery

HYDROMETRY

In order to check the batteries hydrometry the operator has to follow the instructions below:

1. By means of a hydrometre draw a small quantity of electrolyte so that the floater reaches the surface;
2. Make sure that the floater inside the hydrometre is not blocked;
3. For a new measurement, after having filled the batteries with distilled water, the operator has to wait until the liquid inside each battery becomes homogeneous.



WATER FILLING UP

1. Fill distilled water up in each battery cell before the recharge. The liquid inside the batteries has to be of 6 mm. over the plates;
2. The operator has to repeat the same operation every time the level decreases (every week).

CHARGE LIMITS

It is not necessary to recharge the batteries if the hydrometry, after a work day, is not under 1,24 (28 Bè). The highest suggested temperature is 45°C. If the electrolyte temperature increases more than 10/12 °C compared to the outside temperature, the batteries can be overcharged.

OFF DUTY OR INACTIVE BATTERIES

Inactive batteries loses their automatically their charge. If batteries do not continually work, the operator has to:

- ☒☒ Charge the batteries once a month with a 'final' stream intensity until gas is spread and the batteries voltage and weight are constant for 3-4 hours. This operation has to be done even if the absolute weight is high;
- ☒☒ Keep the batteries in a dry room.

BATTERIES TECHNICAL FEATURES

TENSION	V 6
CAPACITAY	240 A/h
PWEIGHT	28 Kg
DIMENSIONS (LxLxH)	240 x 180 h 280

BATTERY CHARGER TECHNICAL FEATURES

IN	V 230, Hz 50, A5
OUT	V 36, A 30

This battery charger can also charge batteries of a different brand.

BATTERIES DISPOSAL

Old batteries are toxic wastes and they have to be thrown in a suitable and authorized place for the batteries disposal. For a short storage, old batteries must be located in an authorized room. Moreover, they must be stored in sealed plastic tanks, whose capacity is not lower than the electrolyte.

SQUEEGEE BLADES REPLACEMENT

Squeegee blades must be replaced when their hedge is worn. A perfect hedge in the blade allows a perfect dry (picture 13).

Follow these instructions to replace the squeegee blades:

1. Remove the squeegee from the machine and lay it on a table;
2. Remove the internal and external knobs, the steel strips and the worn blades;
3. Set the new blades up, tighten the knobs and regulate the squeegee.

Picture 13

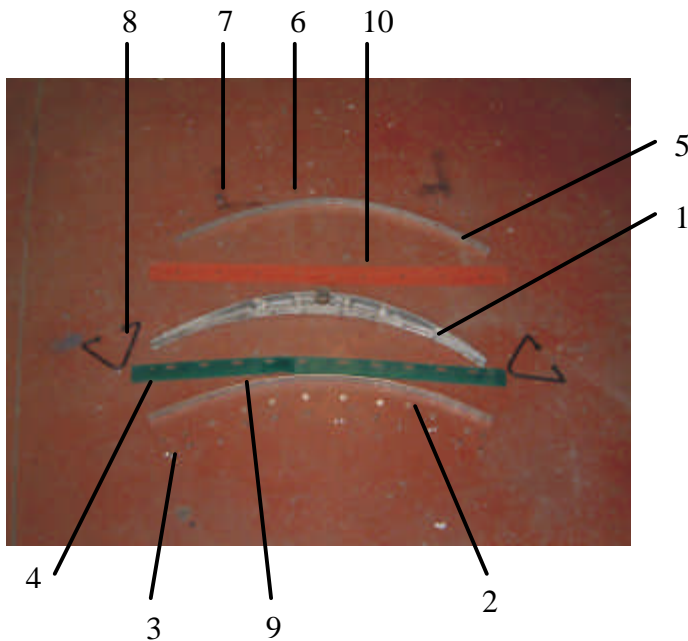

- | |
|------------------------|
| 1. Squeegee |
| 2. Washer |
| 3. Throttle |
| 4. Rear rubber blade |
| 5. Front steel |
| 6. Washer |
| 7. Throttle |
| 8. Side bumper |
| 9. Rear steel |
| 10. Front rubber blade |

SUCTION ENGINE MAINTENANCE

The suction motor has to be checked up and cleaned. Every six months motor brushes have to be checked and replaced if it is necessary.

In order to maintain the suction motor please follow the instructions below:

1. Take the ignition key off the dashboard, disconnect the plug, remove the steel plate that fixes the suction motor and the motor itself (picture 14);
2. Remove the sponge filter under the motor, wash it and put it again in its position;
3. Check the motor fan through the hole in the front side of the suction motor;
4. Remove the plastic cover, loosen the screws and both the brushes supports and check the motor brushes (see detail 2 in picture 5.1);
5. Do now the opposite operations to set everything up again.

Picture 14

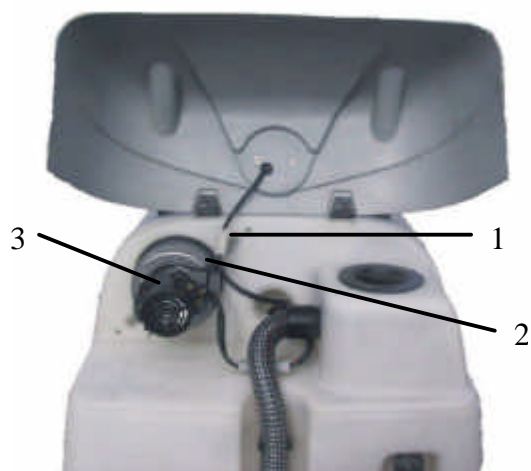

- | |
|---|
| <ol style="list-style-type: none">1. plug for cables connection2. coal brushes engine3. engine fastening plates |
|---|

Trained personnel only can service the machine and especially electric and electromechanical parts by means of suitable tools and equipments. Make reference to FIORENTINI S.r.l. only for service and spare parts.



CONTROLS

A trained technician has to check if the machine is safe and if it shows any particular damage or defect before the first starting or after changes and repair.

CHECKING THE SAFETY SYSTEM

Every year a trained technician has to check the safety device of the machine. In particular, the machine has to be completely overhauled every 5 years by a FIORENTINI technician.

CHECKING THE ELECTRIC SYSTEM

It is very important to check the electric system up every two years. Disconnected cables or burnt cables must be immediately replaced.

Interventions on the electric system must be carried out by a trained technician.











Every kind of intervention not explained in the operator manual must be carried out by FIORENTINI's technicians.

CHECKING THE BRAKING SYSTEM

The braking system has to be checked every 3 months.

DIAGNOSTIC

The electronic card is equipped with a particular system which shows the machine errors through quick flashings on the battery charger display placed on the dashboard. The number of switched on LEDs represents one of the errors listed below:

	10 Leds	Battery overvoltage
	9 Leds	***
	8 Leds	Defect on the control card
	7 Leds	Defect on the forward pedal
	6 Leds	Recovery tank full
	5 Leds	Defect on the suction engine
	4 Leds	***
	3 Leds	Defect on brushes engine
	2 Leds	Defect on the traction engine
	1 Led	Uninsufficient battery voltage



SUMMARY

	HOW OFTEN	TECHNICIAN
INSPECTION		
Safety devices	Every 2 years	Trained technician
Electric system	Every 2 years	FIORENTINI technician
Braking system	Every 3 months	Trained technician
Complete check up	Every 5 years	FIORENTINI technician
MAINTENANCE		
Recovery tank cleaning	Every day	Operator
Clean water tank	Every month	Operator
Suction motor filter	Every day	Operator
Suction pipes cleaning	Every week	Operator
Squeegee cleaning	Every week	Operator
Squeegee blades	Every week	Operator
Battery water level	Every week	Operator
Battery cables fixing	Every 6 months	Trained technician

fiorentini





Mat. n.
Serial no.
Nr. de serie

Data di spedizione
Shipment Date
Date de spedition

Distributed by:

ING. O. FIORENTINI s.r.l.

“THE BEST IN FLOOR MACHINES”

FILIALI:

20132 MILANO – Fax. 02/2592779

Via PalmaFIORENTINI 211/a – Tel. 02/27207783 - 2564810

00155 ROMA – Fax. 06/22754075

Via Carlo Carrà 13 – Tel. 06/22754040-2275060

STABILIMENTO:

50030 PIANCALDOLI (FI) – Fax. 055/817144

Loc. Rombola – Tel. 055/8173610