

User's Manual

PMM 7010

EMI Precompliance RECEIVER

Option 7010/00: 150 kHz ÷ 1000 MHz

Option 7010/01: 9 kHz ÷ 1000 MHz

Option 7010/02: 9 kHz ÷ 30 MHz

Option 7010/03: 9 kHz ÷ 3000 MHz

SERIAL NUMBER OF THE INSTRUMENT

You can find the Serial Number on the rear panel of the instrument.

Serial Number is in the form: 0000X00000.

The first four digits and the letter are the Serial Number prefix, the last five digits are the Serial Number suffix. The prefix is the same for identical instruments, it changes only when a configuration change is made to the instrument.

The suffix is different for each instrument.

NOTE:

© Names and Logo are registered trademarks of Narda Safety Test Solutions GmbH and L3 Communications Holdings, Inc. – Trade names are trademarks of the owners.

If the instrument is used in any other way than as described in this Users Manual, it may become unsafe

Before using this product, the related documentation must be read with great care and fully understood to familiarize with all the safety prescriptions.



To ensure the correct use and the maximum safety level, the User shall know all the instructions and recommendations contained in this document.

This product is a **Safety Class I** instrument according to IEC classification and has been designed to meet the requirements of EN61010-1 (Safety Requirements for Electrical Equipment for Measurement, Control and Laboratory Use).

In accordance with the IEC classification, the battery charger of this product meets requirements **Safety Class II** and **Installation Category II** (having double insulation and able to carry out mono-phase power supply operations).









This product has a **Pollution Degree II** normally only non-conductive pollution occurs. Occasionally, however, a temporary conductivity caused by condensation must be expected.





The information contained in this document is subject to change without notice.

EXPLANATION OF ELECTRICAL AND SAFETY SYMBOLS :

 You now own a high-quality instrument that will give you many years of reliable service. Nevertheless, even this product will eventually become obsolete. When that time comes, please remember that electronic equipment must be disposed of in accordance with local regulations. This product conforms to the WEEE Directive of the European Union (2002/96/EC) and belongs to Category 9 (Monitoring and Control Instruments). You can return the instrument to us free of charge for proper environment friendly disposal. You can obtain further information from your local Narda Sales Partner or by visiting our website at www.narda-sts.it.

	Warning, danger of electric shock		Earth
	Read carefully the Operating Manual and its instructions, pay attention to the safety symbols.		Unit Earth Connection
	Earth Protection		Equipotential

EXPLANATION OF SYMBOLS USED IN THIS DOCUMENT :

	DANGER	The DANGER sign draws attention to a potential risk to a person's safety. All the precautions must be fully understood and applied before proceeding.
	WARNING	The WARNING sign draws attention to a potential risk of damage to the apparatus or loss of data. All the precautions must be fully understood and applied before proceeding.
	CAUTION	The CAUTION sign draws attention against unsafe practices for the apparatus functionality.
	NOTE:	The NOTE draw attention to important information.

Contents

Explanation of electrical and safety symbols.....	Page II
General safety considerations and instructions.....	X
EC Conformity Certificate.....	XI
1. General Information	Page
1.1 Documentation.....	1-1
1.2 Operating Manual changes.....	1-1
1.3 Introduction to PMM 7010.....	1-1
1.4 Instrument Items.....	1-2
1.5 Optional accessories.....	1-2
1.6 Other accessories.....	1-2
1.7 Main Specifications.....	1-3
1.8 Front Panel.....	1-5
1.9 Rear Panel.....	1-6
1.10 Functional Description.....	1-7
1.11 Ultra fast measurement: a unique feature of the PMM 9010.....	1-7
1.12 Emission measurement.....	1-8
2 Installation	Page
2.1 Introduction.....	2-1
2.2 Initial Inspection.....	2-1
2.3 Packing and Unpacking.....	2-1
2.4 Preparation for Use.....	2-1
2.5 Power supply.....	2-1
2.5.1 To replace the mains connector of the universal adapter.....	2-1
2.5.2 Indication of the Power status with LINE led.....	2-2
2.6 Environment.....	2-2
2.7 Return for Service.....	2-2
2.8 Equipment Cleaning.....	2-2
2.9 Equipment ventilation.....	2-2
2.10 Hardware Installation.....	2-3
2.11 Using an Artificial Mains Network (AMN or LISN).....	2-4
2.12 Using Pulse Limiter.....	2-4
2.13 Using Current and Voltage Probes.....	2-4
2.14 Using Antennas and other Transducers.....	2-4
2.15 The User Port.....	2-5
2.16 HXYZ 9170 Triple Loop Antenna remote cable Configuration for 7010...	2-6
2.17 PMM LISNs Three phase Remote cable configuration for PMM 7010 (L3-25 excluded).....	2-7
2.18 PMM L3-25 remote cable Configuration for PMM 7010.....	2-8
3 Setup and Panel Instructions	Page
3.1 Introduction.....	3-1
3.2 Operating mode.....	3-1
3.2.1 SWEEP MODE.....	3-1
3.2.2 ANALYZER MODE.....	3-2
3.2.3 MANUAL MODE.....	3-2
3.3 Detectors.....	3-3
3.3.1 RSM-AVG Definition.....	3-3
3.3.2 RSM-AVG Activation Procedure (option).....	3-3
3.3.3 C-AVG Definition.....	3-4
3.3.4 Smart detector.....	3-4
3.4 RBW Filters.....	3-5
3.4.1 MIL Filter.....	3-5
3.5 Hold time.....	3-6

4. Applications	Page
4.1 Measuring the EMI Voltage.....	4-1
4.1.1 Measuring Principle with a LISN.....	4-1
4.1.2 Coupling Networks.....	4-1
4.1.2.1 AMN.....	4-2
4.1.2.2 Current probe.....	4-3
4.1.2.3 Voltage probe.....	4-3
4.1.3 Test setup.....	4-4
4.1.4 Guidance on a preliminary Measuring Procedure.....	4-4
4.1.5 Remarks and hints for Measuring.....	4-5
5. Updating firmware and Activation code Utility	Page
5.1 Introduction.....	5-1
5.2 System requirements	5-1
5.3 Preparing the Hardware.....	5-1
5.4 Software installation.....	5-1
5.5 To transfer data.....	5-3
5.6 7010 WrDongle utility	5-5
6 PMM 9010-RMA Rack Mount Adapter for Rack 19”	Page
6.1 Introduction.....	6-1
6.2 Instruments Items.....	6-1
6.3 Optional accessories.....	6-1
6.4 PMM 9010-RMA Main Specifications.....	6-2
6.5 PMM 9010-RMA Front view.....	6-2
6.6 PMM 9010-RMA Inside view.....	6-3
6.7 Rack requirements.....	6-4
6.8 Required equipment.....	6-4
6.9 Moving chassis.....	6-4
6.10 Installation guidelines	6-5
6.11 Installing the PMM 9010-RMA.....	6-6
6.12 Use of the PMM 9010-RMA with PMM 9010.....	6-7
7 Remote control	Page
7.1 Introduction	7-1
7.2 Communication	7-1
7.3 Protocol	7-1
7.4 Format	7-1
7.5 PMM 7010 COMMANDS	7-2
7.5.1 QUERY Commands	7-2
7.5.2 SETTING Commands	7-5
7.5.3 Analyzer Reply	7-16
7.5.3.1 Reply example	7-16
7.5.4 Sweep Structure	7-18
7.5.5 Procedure to read a measure stored by the PMM 9010	7-21

Figures

Figure		Page
1-1	Front Panel 7010.....	1-5
1-2	Rear Panel 7010.....	1-6
2-1	PMM Emission Suite and 7010 initial screen showing the last sweep.....	2-3
2-2	HXYZ 9170 remote cable configuration for 7010.....	2-6
2-3	PMM LISN three phase remote cable configuration for 7010.....	2-7
2-4	PMM L3-25 remote cable configuration for PMM 7010.....	2-8
4-1	AMN Principle: a) Δ -type or T-type LISN ; b) V-type LISN.....	4-2
4-2	Example of test Setup for RFI Voltage Measurements.....	4-3
6-1	Front view 9010-RMA.....	6-2
6-2	Inside view 9010-RMA.....	6-3
6-3	PMM 9010-RMA with 9010 Instrument.....	6-7

Tables

Table		Page
1-1	Main Specifications 7010.....	1-3
6-1	Main Specifications 9010-RMA.....	6-2



SAFETY RECOMMENDATIONS AND INSTRUCTIONS

This unit has been designed and tested in Italy, according to IEC 348 standard and has left the manufacturer's premises in a state fully complying with the safety standards ; in order to maintain the unit in a safe state and to ensure safe operation, the following instructions must be reviewed and fully understood before operation.

- When the unit is to be permanently cabled, first connect an uninterruptible protective earth ground conductor before making any other connections.
- If the unit is to be connected to other equipment or accessories, prior to energizing either unit verify that a common ground exists between them.
- For permanently cabled unit without built-in fuses, automatic circuit breakers or similar protective facilities, the power supply line shall be provided with fuses or protections rated to the unit.
- Verify that the unit is set to match the available mains voltage and correct fuse rating is installed before applying power.
- The Safety Class I units provided with disconnectible AC supply cable and plug may only be operated from a power socket with protective earth ground connection.
- Any interruption or loosening of the protective earth ground conductor, either inside or outside the unit or in an extension cable will cause a potential shock hazard that could result in personal injury.
- The protective earth ground conductor shall not be interrupted intentionally.
- To avoid electrical shock do not remove protections or covers of the unit , refer to qualified NARDA Servicing Center for maintenance of the unit.
- To maintain adequate protection against fire hazard, replace fuses only with others of the same type and rating;
- Observe safety regulations and rules and also the additional safety instructions specified in this manual for prevention of accidents.

EC Conformity Certificate

(in accordance with the Directives: EMC 2004/108/EEC and Low Voltage 2006/95/EEC)

This is to certify that the product: PMM 7010 EMI CISPR Receiver
Produced by: NARDA Safety Test Solution
Via Benessea 29/B
17035 Cisano sul Neva (SV) – ITALY

complies with the following European Standards :
Safety: CEI EN 61010-1 (2001)
EMC: EN 61326-1 (2007)

This product complies with the requirements of Low Voltage Directive 2006/95/EEC and with the EMC Directive 2004/108/EEC.

NARDA Safety Test Solution

This page has been left blank intentionally

1 – General Information



1.1 Documentation

Enclosed with this manual are:

- a service questionnaire to send back to NARDA in case an equipment service is needed
- an accessories checklist to verify all accessories enclosed in the packaging.

1.2 Operating Manual Changes

Instruments manufactured after the printing of this manual may have a serial number prefix not listed on the title page; this indicates that instruments with different Serial Number prefix may be different from those documented in this manual.

1.3 Introduction to PMM 7010

PMM 7010 is a EMI receiver, a precompliance system to measure conducted and radiated interferences from: 150 kHz up to 1000 MHz (Option 7010/00), 9 kHz up to 1000 MHz (Option 7010/01), 9 kHz up to 30 MHz (Option 7010/02) and 9 kHz up to 3000 MHz (Option 7010/03).

All measurements performed by the PMM 7010 are according to the most accepted standards like: IEC, CISPR, EN (EuroNorm), FCC, VDE,...

Thanks to its built-in Line Impedance Stabilization Network (LISN), PMM 7010 is able to autonomously measure and characterize DUTs for the conducted emissions.

The PMM 7010 has been designed adopting an innovative philosophy made possible only in the recent years by the availability of superior technology components. This equipment is fully digital but the input first RF conversions and therefore combines into a pure EMI Receiver and Signal Analyzer the precision and accuracy of a numeric approach, with flexibility and user friendly approach typical of a modern instrument.

1.4 Instrument Items

PMM 7010 includes the following items:

- EMI Receiver
- External power supply/battery charger;
- Flexible black cover/accessories holding;
- RS232 cable, 2m;
- USB cable, 2m;
- Operating manual;
- PMM 7010 Utility Software on CD;
- Certificate of Compliance;
- Return for Repair Form.

1.5 Optional accessories

PMM 7010 can be used with several optional accessories, the most common being the following:

- PMM 9010-RMA Rack Mount Adapter for Rack 19"
- L2-16B: single phase AMN, 16A;
- L3-32: four lines, 3-phase, 32A LISN, (50Ω//5 Ω+50μH);
- L3-64: four lines, 3-phase, 63A LISN, (50Ω//5 Ω+50μH);
- L3-64/690: four lines, 3-phase, 63A LISN, (50Ω//5 Ω+50μH);
- L3-100: four lines, 3-phase, 100A LISN, (50Ω//5 Ω+50μH);
- L1-150M: single line LISN, 150A (50Ω//1 Ω+5μH);
- L1-150M1: single line LISN, 150A (50Ω//1 Ω+5μH);
- L1-500: single phase, 500A LISN, (50Ω//5 Ω+50μH);
- L3-500: four lines, 3-phase, 500A LISN, (50Ω//5 Ω+50μH);
- L2-D: Delta LISN for telecom, 2A, 150Ω
- SBRF4 RF Switching Box (Switching Box for LISNs and Loop Antennas)
- LISN Service Kit (AC-BNC adapter for LISNs verification and calibration)
- SHC-1: 35 dB CISPR Voltage probe, 1500Ω;
- SHC-2: 30 dB CISPR Voltage probe, 1500Ω;
- RA-01: Rod Antenna (10 kHz – 30 MHz);
- BC-01: Biconical Antenna (30 – 200 MHz)
- LP-02: Log Periodic Antenna (200 MHz – 3 GHz)
- LP-03: Log Periodic Antenna (800 MHz – 6 GHz)

1.6 Other accessories

Of course, the PMM 7010 can be used with other accessories available on the market, like:

- LISNs, any type;
- Antennas and Loops;
- Near Field Probes;
- Various TEM/GTEM Cells;
- HXYZ 9170 Triple Loop Antenna .

1.7 Main Specifications

Table 1-1 lists the PMM 7010 performance specifications.

The following conditions apply to all specifications:

- The ambient temperature shall be -5°C to 45°C

TABLE 1-1 Main Specifications	
Electrical Characteristics	Performance Limits
Frequency range	150 kHz to 1 GHz (Option 00) 9 kHz to 1 GHz (Option 01) 9 kHz to 30 MHz (Option 02) 9 kHz to 3 GHz (Option 03)
Resolution Frequency accuracy	10 Hz < 3 ppm
RF input VSWR 10 dB RF att. 0 dB RF att. Attenuator Pulse Limiter	Z_{in} 50 Ω , N fem. < 1,2; < 2 over 1 GHz < 1,2; <1,4 over 30 MHz; < 2 over 1 GHz 0 dB to 35 dB (5dB steps) 0 dB to 50 dB (2dB steps) over 30 MHz Built in up to 30 MHz
Max input level Sinewave AC voltage Pulse spectral density	(without equipment damage) 140 dB μ V (2 W) 100 dB μ V/MHz
Preselector (Permanent built-in)	9 kHz to 30 MHz 30 MHz to 1 GHz 1 GHz to 3 GHz
IF bandwidth 6dB bandwidth CISPR 16-1-1	 1 (Opt. 01, 02, 03), 3, 10, 30, 100, 300 kHz, 1 MHz (Opt. 03) 200 Hz (Opt. 01, 02, 03), 9 kHz and 120 kHz
Noise level (Att. 0 dB, 50 Ω term., Hold Time 1 s)	0,009 to 0,15 MHz (200 Hz RBW) < 0 dBuV (QP) (-130 dBm/Hz) < -3 dBuV (AV) (-133 dBm/Hz) 0,15 to 30 MHz (9 kHz RBW) < 14 dBuV (QP) (-128 dBm/Hz) < 7 dBuV (AV) (-135 dBm/Hz) 30 to 1000 MHz (120 kHz RBW) < 14 dBuV (QP) (-144 dBm/Hz) < 7 dBuV (AV) (-151 dBm/Hz)

	1000 to 2700 MHz < 16 dBuV (AV) (-151 dBm/Hz) (1 MHz RBW) 2700 to 3000 MHz < 19 dBuV (AV) (-148 dBm/Hz) (1 MHz RBW)
Spurious response (Att 0dB, 50Ω term, det. PK, Hold time 10 ms)	< 20 dBμV; < 23 dBμV over 2700 MHz
Detectors	Peak, Quasi-peak, Average, RMS, RMS-Average (optional), C-Average, Smart Detector function
Level measuring time (hold time)	0,2 ms to 120 s (CISPR 16-1-1 as default)
Display units With PMM Emission Suite SW (80 to 200 dB selectable dynamic)	dBm, dBμV, dBμA, dBpW, dBμV/m, dBμA/m, dBpT,
Measurement accuracy S/N > 20 dB	9 kHz to 1 GHz ± 1,0 dB 1 GHz to 3 GHz ± 1,5 dB
CISPR 16-1-1 conformity	Standard compliant QP detector down to 20 Hz PRF
Demodulation	AM – FM Internal loudspeaker
I/O Interface	USB 2.0; RS-232; User Port (drives PMM LISNs and accessories)
Operating temperature	-5 °C to 45 °C
Power supply	12 Vdc, 0,8A (AC universal adapter)
Built-in LISN	
Frequency range	9 kHz to 30 MHz
Continuous rated output current	16 A
Max permissible operating voltage	250 Vac – 350 Vdc
EUT supply frequency range	DC to 60 Hz
CISPR equivalent circuit	50 Ω // (5 Ω + 50 μH)
EUT Power connector	Schuko 2P+E
Artificial Hand	4 mm socket
Dimensions (W x H x D)	235 x 105 x 335 mm
Weight	5,0 kg

1.8 Front Panel



Fig. 1-1 7010 Option 00 Front Panel

Legend from left to right:

- **Line** Power led
- **DATA RX-TX** Leds which show the serial communication status
- **RF INPUT** N female RF Input connector
- **RF IN** This led indicates if the signal source is from the internal LISN or from the N connector
- **L1 – L2** These two leds indicate the line of the internal LISN under investigation.
- **Artificial Mains Network 16A** It is the mains socket where the supply of the EUT must be connected to measure its conducted emissions. The line comes through the internal LISN and is capable of handling 16A of max current.
- **Artificial Hand** standard 4 mm socket
- **Earth ground connector**

1.9 Rear Panel



Fig. 1-2 7010 Option 00 Rear Panel

Legend from left to right:

- **Product Label and Serial Number**
- **Mains socket to connect the EUT to the mains through the internal LISN.**
- **Earth ground connector**
- **USER PORT** User I/O Port
- **Fan** Cooling Fan controlled by firmware
- **RS232** 9 pin, DB9 connector
- **On-Off switch** Power switch
- **USB** Fully functional USB 2.0 Port
- **Power Supply** Power Supply Input to power the apparatus.

1.10 Functional Description

The PMM 7010 features a completely new receiver architecture based on the most recent DSP and FPGA technology.

1.11 Fast and precise measurement

This measurement system has been designed for use on any PC with the Windows™ operating system.

The PMM 7010 pre-compliance measurement system allows the designer to measure the conducted and radiated interferences of a prototype under test as part of the daily routine.

In the CISPR bands A (9 kHz ÷ 150 kHz), B (150 kHz ÷ 30 MHz), C (30 ÷ 300 MHz) and D (300 ÷ 1000 MHz) the standards requires the use of specially shaped 200 Hz, 9 kHz, and 120 kHz filters.

Thanks to its architecture and to the large internal computation capability, the PMM 7010 can perform the entire band test in a short time.

This feature is not only useful to greatly increase the productivity of the test lab, but also to make better and more comprehensive analysis in case the disturbance to be evaluated is somehow intermittent and with an irregular repetition rate.

PMM 7010 makes use of internal numerically modelled filters in compliance with the norms, using FFT and FIR techniques.

1.12 Emission measurements

All electric and electronic devices are potential generators of Electro-Magnetic Interference (EMI).

The term EMI thus refers to the electromagnetic energy emitted by a device which propagates itself along cables or through the air and couples with other devices that are present in the surroundings.

These electromagnetic fields (conducted or radiated interferences) may generate interfering currents and voltages into nearby equipment and therefore can cause possible malfunctions.

In order to prevent and control such interferences there are nowadays a number of national and international standards, like IEC and CISPR, which specifies limits and methods of tests. Moreover, within the European Union the application of several European Norms on Electromagnetic Compatibility is enforced by law and therefore the commercialization and use of all the electric and electronic equipment is subject to the measurement of the EMC characteristics, which must be within well defined limits.

The design approach adopted for the PMM 7010 is that the instrument shall be innovative, full compliant with all the relevant standards and at the same time simple and reliable to use, to be the base building block for any possible emission system to measure and evaluate any electric or electronic device from the very first design stages to the final certification.

The need to precisely measure the conducted and radiated EMI noises forces the equipment manufactures to use reliable equipment to verify the limits imposed by the relevant standards and/or enforced by local rules.

In this view the PMM 7010 receiver is the ideal solution from prototype debugging to final certification, as it fully meets all the performance criteria dictated by these standards, although it remains small, lightweight and very easy to use.

The PMM 7010 Utility control software permits an immediate use of the instrument without any training or special difficulties: the operator can concentrate just on analyzing the measurement results.

Moreover, the PMM 7010 software has also been designed for a fast and easy installation on any PC with the Windows™ operating system and with at least one free USB or Serial Port.

The device under test (DUT) must be installed according to the procedures indicated in the constructor's manual and normal operating conditions respected.

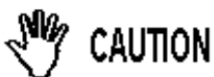

Be sure not to overload PMM 7010: the input signal should not exceed the maximum level indicated in the main specifications in chapter 1. Also do not apply any signal to RF generator output connector.

2 - Installation

2.1 Introduction

This section provides the information needed to install your PMM 7010. It includes the information pertinent to initial inspection and power requirements, connections, operating environment, instrument mounting, cleaning, storage and shipment.

2.2 Initial Inspection

When receiving the equipment, first inspect the shipping cardbox for any damages.

If the shipping box is damaged, it should be kept until the contents of the shipment have been checked for completeness and the instrument has been checked mechanically and electrically.

2.3 Packing and Unpacking

Verify the availability of all the shipped items with reference to the shipping check list enclosed with the Operating Manual.

Notify any damage to the forwarder personnel as well as to your NARDA Representative.



WARNING

To avoid further damage, do not turn on the instrument when there are signs of shipping damage to any portion of it.

2.4 Preparation for Use



WARNING

This is a Safety Class I apparatus, and it is also equipped with protective/functional earth terminals on the rear and front panels. A good safety/functional ground connection should be provided before to operate the system.

2.5 Power Supply

The universal adapter supplied with the receiver can work at either 50 Hz or 60 Hz with a supply voltage rated between 100 and 240 Volt.

It is supplied with different connectors to fit all the possible outlets in accordance with the various National standards.



Power supply: DC, 12 V, ~ 800 mA
=> DC Connector

2.5.1 To replace the mains connector of the universal adapter

To replace the mains connector, simply remove the one installed on the battery charger sliding it off, and insert the one that fits the outlets in use.

2.5.2 Indication of the Power status with LINE led

When the wall universal adapter is connected to the PMM 7010 and the power is switched ON the LINE led lights up.

After just a short time since the power has been switched on, the PMM 7010 is ready for use.

2.6 Environment

The operating environment of the receiver is specified to be within the following limits:

- Temperature -5 °C to +45 °C
- Humidity < 90% relative
- Altitude 4000 meters

The instrument should be stored and shipped in a clean, dry environment which is specified to be within the following limitations:

- Temperature -40 °C to + 50 °C
- Humidity < 95% relative
- Altitude 15.000 meters

2.7 Return for Service

If the instrument should be returned to NARDA for service, please complete the service questionnaire enclosed with the Operating Manual and attach it to the instrument.

To minimize the repair time, be as specific as possible when describing the failure. If the failure only occurs under certain conditions, explain how to duplicate the failure.

If possible, reusing of the original packaging to ship the equipment is preferable.

In case other package should be used, ensure to wrap the instrument in heavy paper or plastic.

Use a strong shipping box and use enough shock absorbing material all around the equipment to provide a firm cushion and prevent movement in the shipping box; in particular protect the front panel.

Seal the shipping box securely.

Mark the shipping box FRAGILE to encourage careful handling.

2.8 Equipment Cleaning

Use a clean, dry, non abrasive cloth for external cleaning of the equipment.

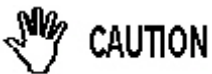

To clean the equipment do not use any solvent, thinner, turpentine, acid, acetone or similar matter to avoid damage to external plastic or display surfaces.

2.9 Equipment ventilation

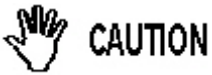

To allow correct equipment ventilation ensure that the vent grids on the rear panel and on the bottom of the receiver are free by any obstructing object.



In order to avoid the unwanted tripping of the protection devices, an insulation transformer shall always be used between the mains supply and the built-in LISN.

2.10 Hardware Installation

PMM 7010 is delivered from factory ready to use. Remove the receiver from its cardboard shipping box, connect properly the universal power supply and switch ON the Power button.

In this way the LINE Led lights up to indicate the receiver is correctly powered.

To avoid unwanted starts and stops, the Power button is placed in an adequate recess.

After having been switched ON, the PMM 7010 boots with its internal BIOS and runs the firmware which manages the receiver.

At the beginning the instrument performs a diagnostic test to check if everything is working properly.

The boot sequence is very fast and the receiver is ready to use in a few seconds after having switched the ON button.

When the initial sequence is completed the receiver is ready to be controlled by the PC, running the PMM Emission Suite software.

The main screen shows the last sweep.

Connect the output of any LISN, or antenna, or absorbing clamp or any other transducers to the RF input, or use the internal LISN for conducted emissions test.

When using a PMM LISN, it is possible to control from the receiver the lines of the LISN and automatically switch between them connecting a special cable between the User Port of the receiver and the LISN remote control input.

Press the button to the "0" position to switch the apparatus OFF.

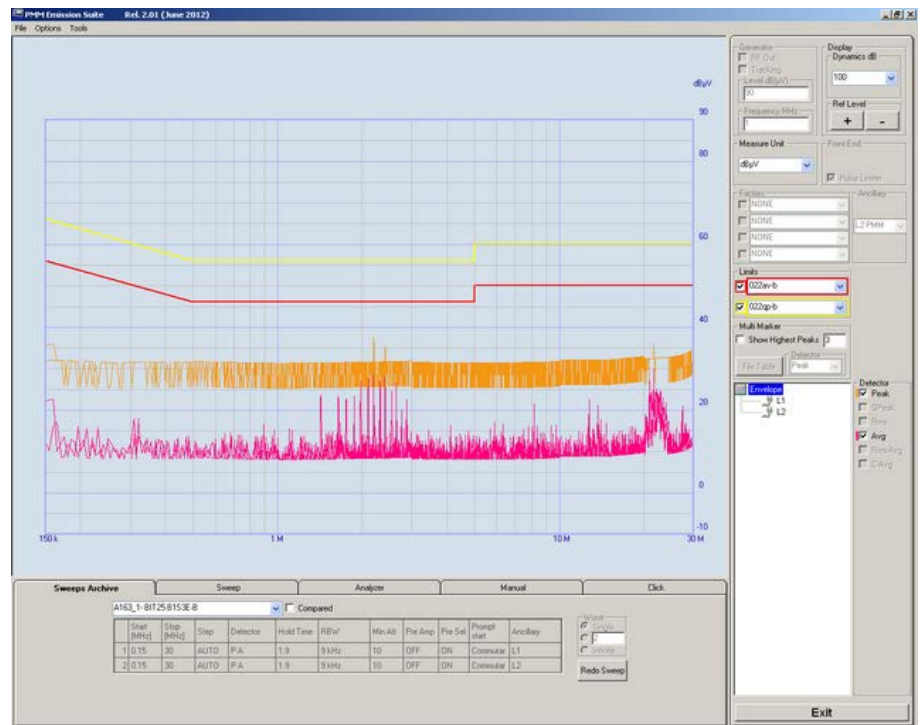

Fig. 2-1 PMM Emission Suite and 7010 initial screen showing the last sweep.

2.11 Using an Artificial Mains Network (AMN or LISN)

When the PMM 7010 receiver is connected to a LISN to perform conducted interference measurements of the EUT, the RF output of the LISN shall be connected to the RF input of the receiver. In order to switch automatically between the lines of the LISN, it shall be connected to the User Port of the receiver thanks to the dedicated cable supplied with the LISN .

If the built-in LISN is to be used, all the connections and commutations are already done internally and automatically.

Using PMM Emission Suite software it is possible to carry out an automatic measurement on all mains lines and get the worst case.



WARNING

In order to avoid the unwanted tripping of the protection devices, an insulation transformer shall always be used between the mains supply and a LISN.

2.12 Using the Pulse Limiter

The built in pulse limiter is a useful device to protect the input of the receiver from transient over voltages. Sometime the conducted disturbances entering the receiver through the LISN are too high - even if they cannot be seen on the PMM 7010 because they are out of measurement bandwidth - and the associate energy is high enough to damage the input circuit.

The pulse limiter has been integrated in the system as a protection of the input from unexpected pulses.



CAUTION

When using an external Artificial Mains Network, to reduce the probability of damages caused by transient voltage pulses always disconnect the PMM 7010 RF input before switching Equipment Under Test supply ON or OFF.

2.13 Using Current and Voltage Probes

When a LISN cannot be used – e.g. when measurements have to be made on terminals other than the mains ones, such as load or command terminals, sensitive to inserted capacities for example, or when LISNs of adequate current capabilities aren't available, or when the line voltage is too high – a current or voltage probe can be used.

The characteristics of these probes, and some advises on their uses, are given in §5 of CISPR 16-1-2.

The CISPR voltage probe contains a resistor with a minimum resistance of 1500 ohm, in series with a capacitor of negligible reactance vs. the resistance (in the 150 kHz to 30 MHz range), and it is insulated at least up to 1500V.

All these probes have an insertion loss and a frequency response that can be stored in the PMM Emission Suite, so that the actual readings of the receiver can be automatically corrected by these characteristics values.

2.14 Using Antennas and other Transducers

In the frequency range from 9 kHz to 1000 MHz any other transducer can be used to pick-up and measure RF conducted and radiated emissions, like active and passive loop antennas, rod, dipole, biconical and log periodic antennas, near field probes etc.

The characteristics of these transducers are usually specified in the relevant standards (e.g. Military or Automotive Standards).

Their use with PMM 7010 is very easy, as it's enough to enter their response with the frequency into the memory of the PMM Emission Suite to have the readings automatically corrected. When the cable is not calibrated together with the transducer, even the cable loss can be entered.

Up to four factors can be used together at the same time.

2.15 The User Port

The PMM 7010 features on the rear panel a programmable User Port that can be used to drive external devices or, more generally, to output signals and data.

The User Port can easily be programmed and managed; the connector has the following hardware connection:

PIN #	Signal
1	nc
2	nc
3	+ 12 VDC (max 50 mA)
4	OUT 0
5	OUT 2
6	nc
7	nc
8 and 9	nc
10	IN 0
11	GND
12	OUT 1
13	nc
14	nc
15	nc

Data output (OUT 0 to OUT 2) and input (IN 0) are opto-coupled TTL level with max. 1 mA draining.

Every other detail about User Port functionality is described in a separate and more specific manual, available upon request.

2.16 Schwarzbeck Model HXYZ 9170 Triple Loop Antenna Remote Cable configuration for PMM 7010

The following figure shows the HXYZ 9170 Triple Loop Antenna remote cable pin configuration. This cable can be requested to Narda or arranged locally.

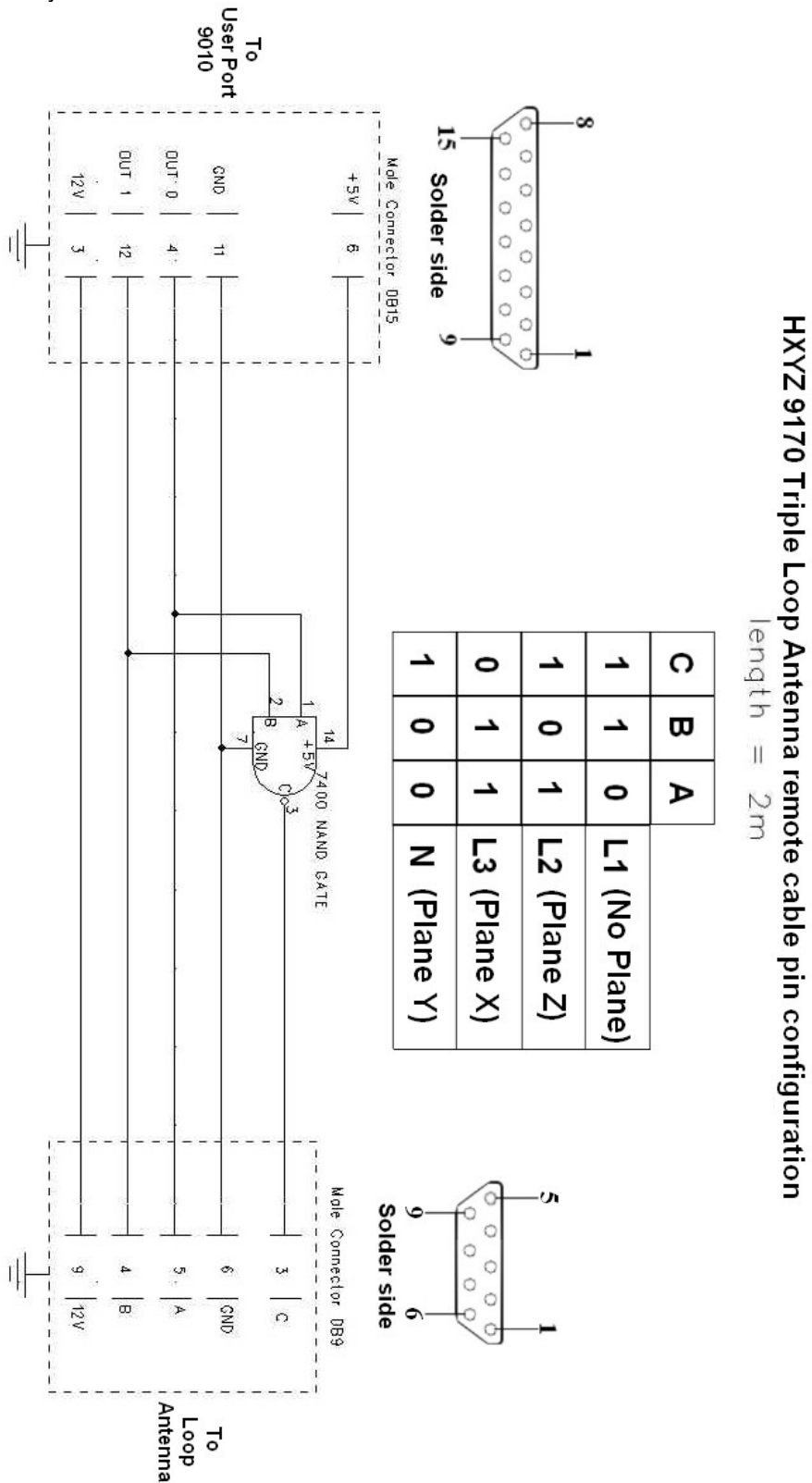

Fig. 2-2 HXYZ 9170 remote cable configuration for PMM 7010

**2.17 PMM LISNs
Three Phase
Remote Cable
configuration
for PMM 7010
(L3-25 excluded)**

The following figure shows the LISN remote cable pin configuration. The cable can be requested to Narda or arranged locally.

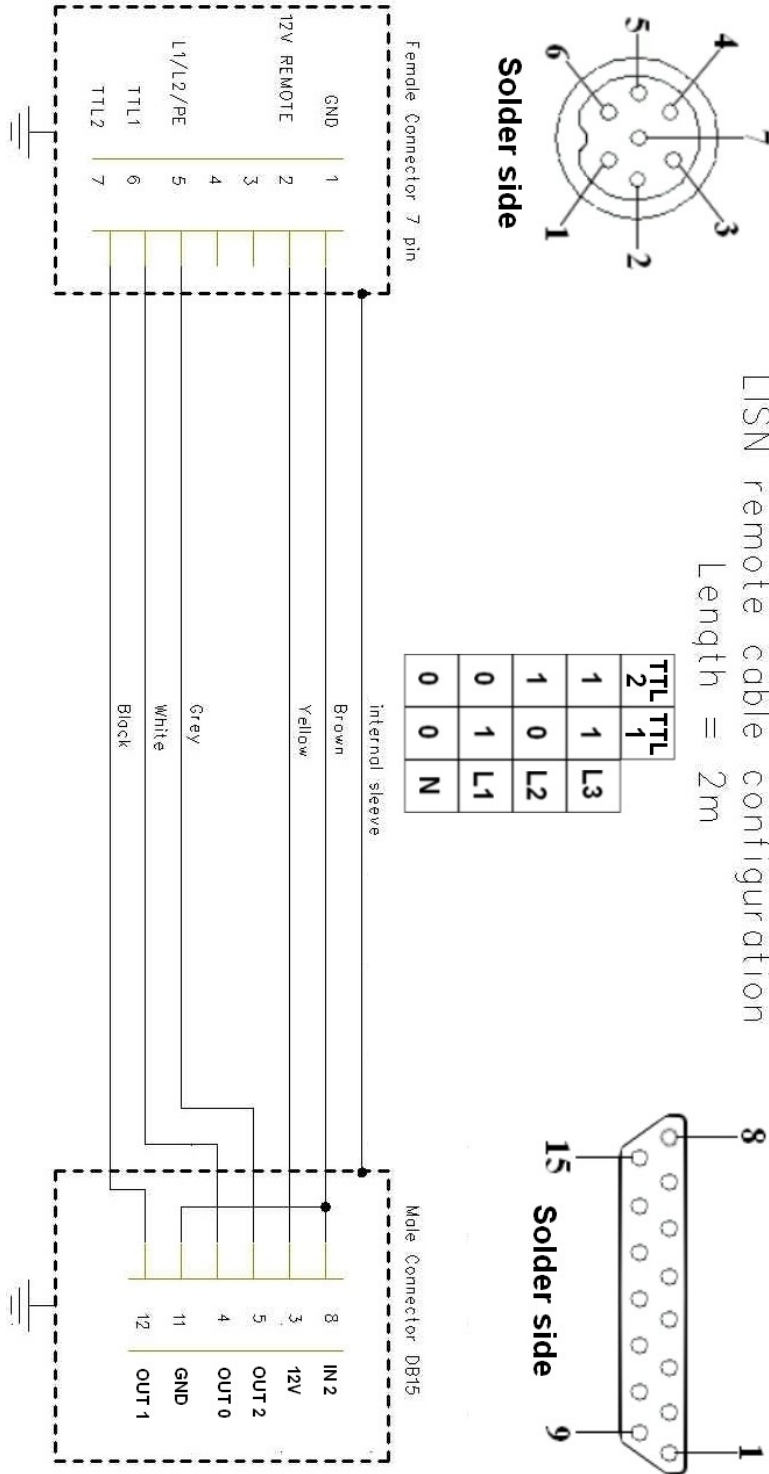

Fig. 2-3 PMM LISN three phase remote cable configuration for PMM 7010

2.18 PMM L3-25 Remote Cable configuration for PMM 7010

The following figure shows the LISN remote cable pin configuration. The cable can be requested to Narda or arranged locally.

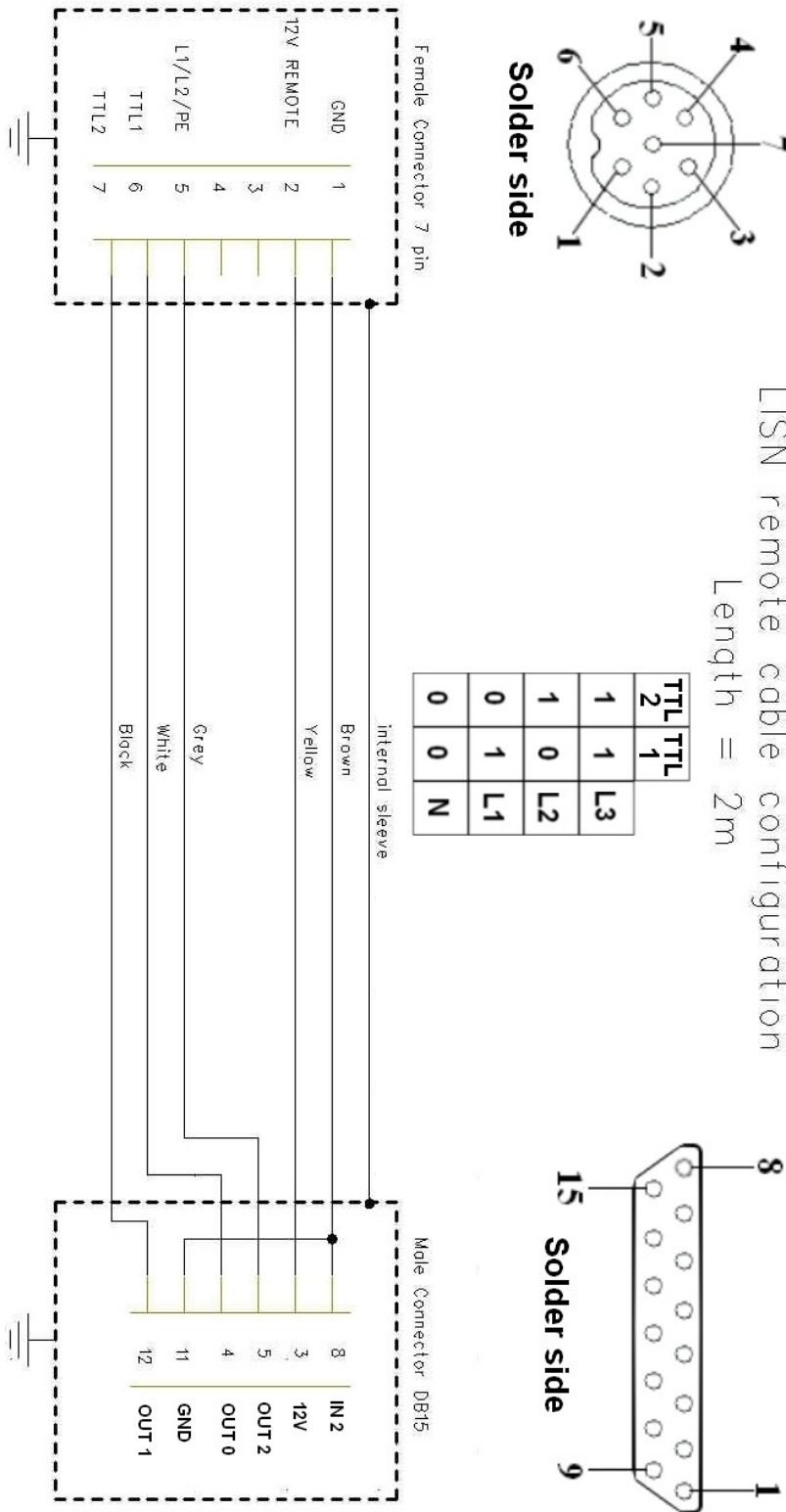

Fig. 2-4 PMM L3-25 remote cable configuration for PMM 7010

3 – Operating Instructions

3.1 Introduction

The PMM 7010 EMI Receiver needs to be driven by a PC through an USB or RS232 serial connection.

The system is provided with a specifically developed software called PMM Emission Suite, which installer utility is stored in the CD shipped together with the instrument.

Please refer to the PMM Emission Suite Manual for any information and instruction concerning the operation of the software.

The **Sweep mode** is used to operate the PMM 7010 as a powerful scanning EMI receiver. To enter in this mode it's enough to depress the Sweep soft key on the main screen, and immediately the scan setup window pops up and allows the operator to set the parameters for the scan. All the automatic settings (RBW, frequency step, etc.) refer to the CISPR standard.

Operating Manual Changes



Instruments manufactured after the printing of the User's manual may have a serial number prefix not listed on the title page; this indicates that instruments with different Serial Number prefix may be different from those documented in the manual itself.

3.2 Operating Modes

Under the control of the PMM Emission Suite PC Software it is possible to use the receiver in different modes of operation.

3.2.1 SWEEP MODE

The **Sweep Mode** is the most common way to perform measurements in the EMI environment.

The Sweep mode is used to operate the PMM 7010 as a powerful scanning EMI receiver. To enter in this mode it's enough to depress the Sweep soft key on the main screen, and immediately the scan setup window pops up and allows the operator to set the parameters for the scan. All the automatic settings (RBW, frequency step, etc.) refer to the CISPR standard.

In Sweep mode the Peak, QPeak, C-Rms, RMS, C-Avg, Avg detectors are available.

All the relevant information are reported on the screen.

In this way the User can see which detector is in use and the relevant hold time; if the function "Smart Detector" is activated and which one; if the input attenuation is Automatic or Manual and the set attenuation and the Minimum attenuation.

On the right it is possible to choose the Reference level. During the scan, in the center above the graph the actual frequency measured is displayed and continuously updated.

Below the graph the start and the stop frequency, and loaded limits, if any.

When the sweep has been executed, on the bottom of the screen the most important sweep parameters are repeated.

3.2.2 ANALYZER MODE

To enter the **ANALYZER Mode** it's enough to depress the Analyzer soft key on the main screen.

In this mode the receiver works as a powerful Spectrum Analyzer and the display shows the "spectrum analysis" in the frequency domain.

The analysis is done at the selected span frequency.

Using the marker facility the User can accomplish a very accurate measurement of the signals either in frequency as well as in level.

On the screen of the Analyzer Mode all the relevant information are reported.

So that the User can see which detector is in use and the relevant hold time; if the input attenuation is Automatic or Manual and the set attenuation and the Minimum attenuation.

Near the the graph there is the Reference level, the Resolution bandwidth and the span value.

Below the graph the start, center and stop frequency.

A proper box is dedicated to the marker indication, with actual frequency and level of the marker.

3.2.3 MANUAL MODE

The **MANUAL mode** is a very useful feature to manually control the receiver and to deeply investigate electrical signals modifying the parameters of receiver exactly as per the needs of the Test Engineer.

It is possible, for example, to observe the signals exceeding the limits frequency by frequency; evaluating their levels measured simultaneously with 4 different detectors (Peak, QuasiPeak, Average and RMS); listening to them after a demodulation, etc.

To enter in **.Manual Mode** press the key in the main menu, and immediately the first Manual window opens.

In manual mode the levels corresponding to the detectors in use are displayed both in analogue and in digital format, and exactly as for the other operating modes, all the relevant information are reported on the screen.

The User can see the resolution bandwidth, the longest hold time associated to the detectors in use; if the input attenuation is Automatic or Manual and the set attenuation and the Minimum attenuation.

Also the Demodulator can be switched on and set to AM or FM, and the audio volume regulated as wished and represented by a simple bar.

Then there are three or fours vertical bars representing the detectors and indicating in analogue and digital (the figures below each bar) the level measured; on top of the bars the relevant detector, the unit in use and the tuned frequency. The analogue scale of the analogue bars is set automatically by the software in accordance with the Reference Level set.

NOTE

In case an **OVERLOAD** indication occurs it is necessary to add an external attenuator to carry on the measurement without overpassing the declared limit for continuous power or spectral density.

Using 0 dB attenuation PMM 7010 has no input protection.

This is a potentially dangerous condition for the input stage of the receiver.

Use 0 dB attenuation only if you are very sure that your input signal is less than 0,5 Vpp (or 106 dB μ V).

CAUTION

Before to apply an unknown signal to PMM 7010 receiver, use an oscilloscope or a wide band RF voltmeter to measure it. In any case set Min. ATT at 10 dB and select the maximum available attenuation.

If needed, add an external coaxial attenuator on the input signal line.

3.3 Detectors

PMM 7010 has been designed to allow the use of many kinds of detectors. CISPR Standard has introduced the application of two detectors that are derived from the Root Mean Squared and from the Average ones.

3.3.1 RMS-AVG Definition

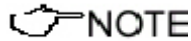

The RMS-Average detector is a payment special function implemented in the PMM 7010 receiver.

RMS-Average detector is manufactured under license of Rohde & Schwarz GmbH & Co. KG.

The RMS-Average detector, according to the CISPR 16-1-1 standard, supplies a reading of the input signal that is weighted, for repeated pulses, such that for a constant indication, the relationship between amplitude and repetition frequency is in accordance with the following rule:

The Amplitude is proportional to (repetition frequency)^{-1/2}

The value is the maximum level during the measurement time (Hold Time) and the averaging is carried out with a lowpass filter of the 2nd order to simulate a mechanical instrument.

The calibration is in reference to the RMS value of an unmodulated sine wave signal.

3.3.2 RMS-AVG Activation Procedure (option)

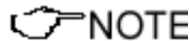

To enable the RMS-AVG Detector use the 7010 Set code Utility.

For further information on software installation refer to the “Updating firmware and Activation code Utility” chapter.

When the 40 Digit Serial Code is sent to the instrument by the Dongle Code Window, selecting the **Write RMS-AVG Dongle** button.

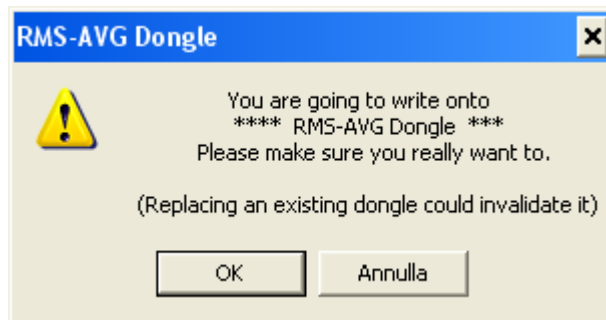

Then press OK to confirm.

The software will inform that the Dongle Code has been successfully stored. Press Ok to close the program.

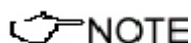

If the Dongle code is not valid an error message appears.

3.3.3 C-AVG Definition

CISPR 16-1-1 defines the Average detector as designed to indicate the weighted average value of the maximum value of the envelope of the signal passed through the pre-detector stages:

up to 1000 MHz, is defined as the response of the measuring receiver to pulses of repetition rate n Hz and impulse area of $1,4/n$ mVs emf at 50Ω source impedance that shall be equal to the response to an unmodulated sine-wave signal at the tuned frequency having an emf with rms value of 66 dB μ V.

The value of n shall be 500 for Band B, and 5000 for Bands C and D.

The average detector is useful to measure narrowband signals to overcome problems associated with either modulation content or the presence of broadband noise.

When the Average is measured according to CISPR 16-1-1, the maximum value of the linear mean envelope during the measurement interval is shown. The detector is used, for example, to measure pulsed sinusoidal signals with a low pulse repetition rate. It is calibrated with the rms value of an unmodulated sine wave signal. Averaging is carried out with lowpass filters of the 2nd order (simulating a mechanical instrument).

3.3.4 Smart Detector

The **Smart Detector** is an innovative special function implemented in the PMM 7010 receiver with the purpose of reducing the test time and increasing the productivity of the lab.

This function works only when at least one limit is loaded, therefore remember to enable a limit to run the Smart detector function.

Selecting one out of the five **Smart detectors** the receiver will execute the scan using at first the Peak detector and, if a peak value is found over the selected limit minus a **Margin** set with the specific button, the reading is re-measured and displayed with the chosen (C-Avg, AVG, C-Rms, RMS or QPeak) detector.

Obviously this way of operation results in a much faster scan sweep and moreover it immediately draws the attention of the test Engineer to the most critical points. The limit associated to the Margin is displayed as a bold colored line and is automatically selected by the receiver depending which Smart detector is chosen; for example, if a Smart QP is selected, the associated QP limit line will be displayed as a bold colored line.

It is immediately clear that this function is very useful to dramatically reduce test time and increase the productivity of the test lab.

To deselect the Smart Detector function simply select a single detector.

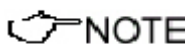

The weighting time must be properly set in the Hold Time window to allow the Smart detectors functions to operate as intended.

The Hold Time is the measurement time the receiver takes to value the input signal and form result weighted by the selected detector.

When using the **C-Avg** (CISPR-Average) or the **C-RMS** (CISPR-RMS) detector, since for definition they are characterized by a long time constant, the minimum measurement time should be set long enough to allow a correct measurement.

For this reason, **when unknown signal are to be measured, the Hold Time should be at least 1000ms** to correctly weight signals pulsed at a rate of 5 Hz or faster.

 **NOTE**

With the Peak, RMS and AVG detectors the smallest settable measurement time depends on the RBW.
If several detectors are used contemporarily the Hold Time should be set to meet the requirement of the slowest one, so that the results of the measurement are correct for all them.

When a frequency change or an attenuation variation occurs, PMM 7010 waits automatically the time needed to the internal circuits to overcome the transient before the measurement time starts again.

3.4 RBW Filters

The **Resolution Bandwidth** box is used to select the bandwidth of the measuring filter.

The drop-down menu allows the User to select from the list, the filter desired. These filters are mathematically modeled using digital techniques and, concerning the 9 and 120 kHz, they are compliant to the CISPR 16-1-1 standard.

Other additional -6dB bandwidth filters are also available: please refer to the instrument specifications paragraph for the complete list.

3.4.1 MIL Filters

The 10 kHz and 100 kHz provided filters are MIL-STD-461E (they are not optional but always available).

 **NOTE**

When a non-CISPR filter is selected, the Quasi Peak, C-RMS and C-AVG detectors are disabled.

3.5 Hold Time

The Hold Time (expressed in milliseconds) represents the time the receiver uses to “take a snapshot” of the incoming signal and to measure it with the chosen detector. When selecting a detector, the default hold time value is automatically loaded, but in some cases this time is not appropriate, e.g. when the interference signals have a low repetition rate or when the standard impose a proper measurement time.

In this case it could happen that the PMM 7010 sees a high input signal and therefore tries to set the proper attenuation automatically increasing the value or the input attenuators. However, when the input attenuation is set the signal is gone, so the receiver lowers the attenuation, but then a new peak arrives, and so on and so forth...

On the other hand, if the Hold Time is too high the PMM 7010 cannot properly follow the signals.

In this situation the Hold Time value should be manually set to find a correct compromise.

To set the Hold Time to the lowest possible value (this value dynamically depends from the measurement conditions), enter the figure 0; if a value lower than the allowed is entered, the lowest possible value is automatically selected.

The max. Hold Time that can be set is 30 sec (30.000 ms).

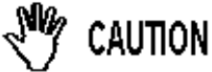

Be sure not to overload PMM 7010: the input signal should not exceed the maximum level indicated in the main specifications in chapter 1. Also do not apply any signal to RF generator output connector.



The weighting time must be properly set in the Hold Time window to allow the desired detectors to operate as intended.

4 – Applications

4.1 Measuring the EMI Voltage

ElectroMagnetic Interference (EMI) voltage measurements on power supply lines or on signal lines are carried out by means of "Coupling Networks" (e.g. LISNs) or other transducers (e.g. antennas, voltage probes). The frequency range is dictated by the applicable standard, however it is generally limited from 9 kHz to 30 MHz in commercial applications, while for measurements on other equipment/accessories - e.g. military, automotive, information technology and communication equipment (ITE), ISDN devices, etc. - the frequency range extends down to 20 Hz and up to 200 MHz, depending the relevant standards.

Nevertheless, the most common tests in the frequency range covered by PMM 7010 are certainly the conducted measurements, done with the help of a LISN, and the radiated ones, for which various types of antennas can be used.

4.1.1 Measuring Principle with a LISN

In the case of a system with two floating conductors, the EMI voltages of the two conductors relative to each other and with reference to the ground form a vector system where three kind of RFI voltages are present (sometime EMI is also referred as RFI: Radio Frequency Interference). They are:

- Symmetrical (or differential mode) voltages. These RFI components are measured between the two conductors. They behave like the wanted signal on the forward and return lines.
- Asymmetrical (or common mode) voltages. These EMI components are measured between the electrical midpoint of the two conductor voltages and reference ground. Usually these are the components most likely to cause interference effects.
- Unsymmetrical voltages. These RFI components are measured from each line conductor and the reference ground. They consist of symmetrical and asymmetrical components. The measurement of these RFI voltages is the easiest to do and the most commonly performed.

Indeed, for practical reasons, Standards mostly specify the measurements of unsymmetrical voltages instead of the theoretically more meaningful common mode EMI, but the standard doesn't necessarily reflect the real life exactly as it is: it shall be a common practice reference aiming to create a database of fully comparable results.

See figure 7-1 for a graphic explanations of these differences between the EMI voltages.

Some Regulations require both measurement of symmetrical and asymmetrical RFI voltages, also defining separate and different limits for them.

4.1.2 Coupling Networks

Coupling Networks are electrical interfaces which allow to "transfer" the quantity to be measured (e.g. EMI voltages or currents) from the lines under test to the receiver.

Some types of Coupling Networks are: AMN (Artificial Mains Network), also known as "LISN" (Line Impedance Stabilization Network), Current Probe and Voltage Probe. Again, Fig. 7-1 also shows the AMN principle.

The PMM 7010 is already equipped with a built-in LISN.

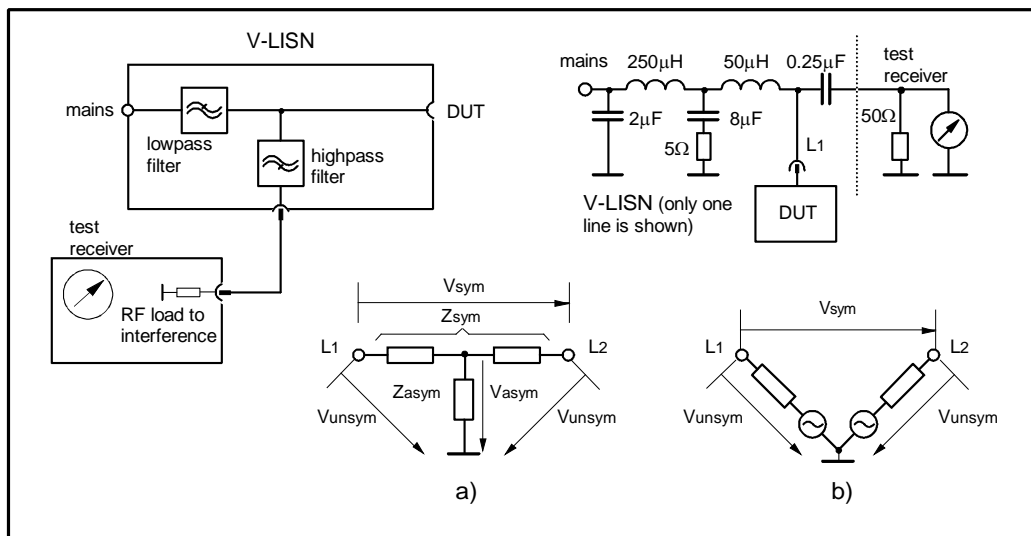

Fig. 4-1 AMN Principle: a) Δ -type or T-type LISN ; b) V-type LISN

4.1.2.1 AMN

AMNs are usually classified depending their configuration: V-type Networks, Δ -type Networks, T-type Networks.

- The V-type Network is used for measuring the unsymmetrical RFI voltage on AC and DC supply line. Standard impedances specified by CISPR and other international standards are $50\Omega // 50\mu\text{H} + 5\Omega$ and $50\Omega // 5\mu\text{H} + 1\Omega$.
- The Δ -type Network is used for measuring the symmetrical RFI voltage on balanced telecommunication lines. It is generally designed to permit switchover between symmetrical and asymmetrical RFI measurements. Its use is limited; Standards usually specify the T-type Network instead. The most common impedance for Δ -type Network is 150Ω .
- The T-type Network is used for measuring the asymmetrical RFI voltage on balanced (electrically symmetrical) audio frequency, control and data lines. Standard impedance is 150Ω as well.

An Artificial Mains Network shall be designed in order to:

1. terminate each line (power, signal, etc.) of the EUT (Equipment Under Test) with a standardized impedance;
2. permit the feeding of the EUT with the proper supply voltage and current or with the signal and data required for operations;
3. isolate the side of the test circuit where EMI voltages are measured against interference coming from mains network or from the auxiliary equipment supplying the EUT with the required data;
4. provide a suitable test point – to be connected to the test receiver - to pick up the RFI voltages from the conductor under test;
5. ensure that the impedance of the source (power, signal) is not varied in a significant way, otherwise EUT response to the interference may change.

4.1.2.2 Current Probe

Current Probes may be Clamp-on Probes or Fixed-ring Probes. Current Probes are used to measure differential or common mode RFI currents. In some cases it may be important to make a distinction between the two kinds of current flowing in a system.

RFI current measurements with Current Probes may be required, for example, when measuring EMI from shielded lines or from complex wiring systems, when finding interference sources among other sources in a system, when performing compliance to some Standards, etc.

4.1.2.3 Voltage Probe

Voltage Probes include Active Probes and Passive Probes. Active Probe has a very high input impedance $Z_{in} > 100 \text{ K}\Omega // < 10 \text{ pF}$. Passive Probe has a standard impedance $Z_{in} = 1,5 \text{ K}\Omega // < 10 \text{ pF}$.

Voltage Probe is used for measuring the unsymmetrical RFI voltage when it is not possible to carry out measurement by interconnecting an Artificial V-type Network. Such situation may occur, for example, when measuring on lines on which only small loads are permissible (control and signal lines), when measuring on a EUT (Equipment Under Test) which would not operate correctly using V-type LISN or a DUT (Device Under Test) requiring very high power supply current for which no V-type LISN is available.

For diagnostic or design purposes on high impedance circuits, Voltage Probe may be used to determine, for example, noisy components or conductors that cause interference on CMOS PC boards. Some Regulations give statements when Voltage Probe are to be used and specify relevant setup and RFI voltage limits.

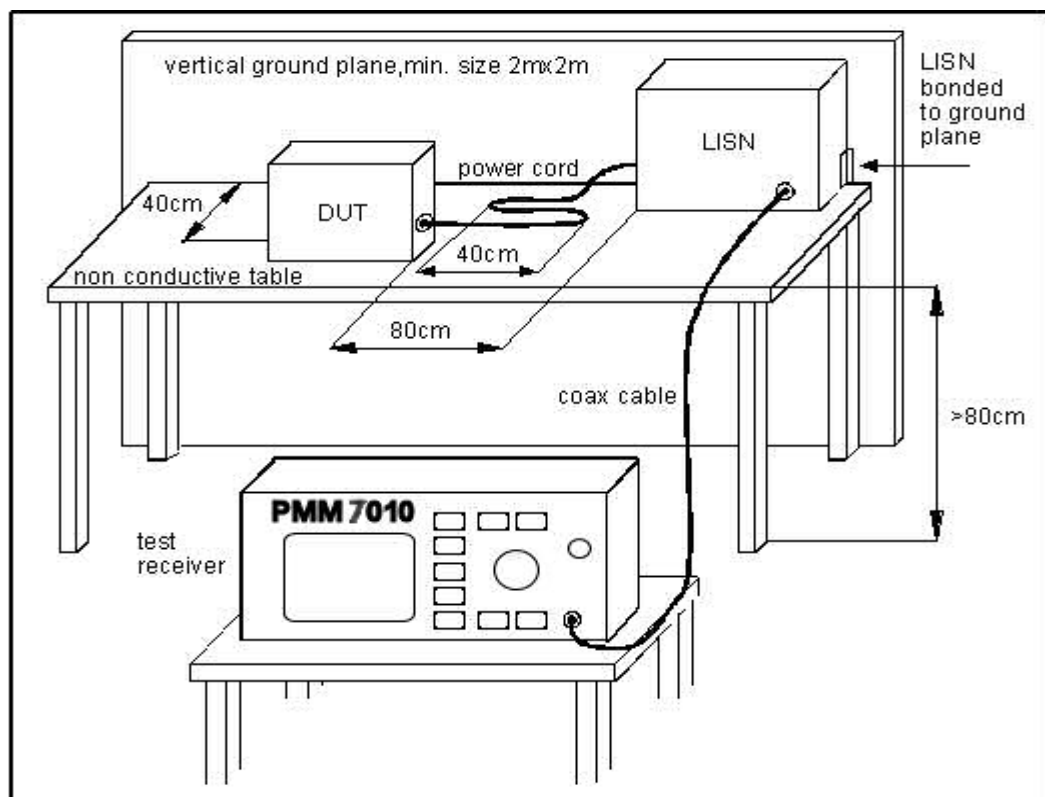

Fig. 4-2 Example of Test Setup for RFI Voltage Measurement

4.1.3 Test Setup

Fig. 7-2. shows an example of test setup for RFI voltage measurement. The DUT is placed 0,4 m from an horizontal or vertical earthed conducting surface of at least 2 m x 2 m in size.

A table top DUT is placed 0,8 m from the LISN and at least 0,8 m from any other earthed conducting surface. If the measurements are made in a shielded room, the DUT shall be placed 0,4 m from one of the walls of the room.

The LISN shall be bonded to the reference conducting surface.

A Floor standing DUT is placed 0,1 m above an horizontal earthed conducting surface of at least 2 m x 2 m in size. This size shall be exceeding by at least 0,5 m the projection of the DUT on the conducting surface. The power cable should be 1m long; longer cable should be centrally bundled for at least 40 cm.

DUTs without a PE (Protective Earth) conductor and manually operated DUTs shall be measured in conjunction with an auxiliary screen or an "Artificial Hand", as duly specified in the relevant standards.

All the details and information on the test setup are written on the latest version of the applicable Standard.

4.1.4 Guidance on a preliminary Measuring Procedure

A step-by-step example of a conducted test manually performed is the following:

1. Switch ON the PMM 7010 and enter in **Sweep** Mode pressing the relevant button;
2. Select **Display** and then **120dB**; Reference Level should be between 110 and 135 dB μ V; press **Esc**;
3. Touch the **Measure** key, then **Freq B Band**;
4. Then **Level, Input** and set the Minimum Attenuation to 10 dB and the Attenuation is automatic; press **Esc**;
5. The **Pulse Limiter** is always enabled to protect the input from voltage spikes;
6. Enter in the **Detector** menu and select **Peak**; press **Esc** two times;
7. Connect the internal LISN or any other suitable transducer to the RF input, selecting the proper phase/line whenever applicable;
8. With the EUT switched OFF touch **Exec Sweep** and wait until the first scan has been finished;
9. Carry out an overview of the whole spectrum and check the by executing a pre-measurement with peak detector that the ambient RF disturbances are at least 20 dB below the desired emission levels;
10. If the ambient noises are low enough continue to the next step, otherwise take all the necessary steps to reduce the ambient disturbances (e.g. go to a shielded room, etc.);
11. Switch ON the EUT and then **Measure, Exec Sweep** again and wait until the scan has been finished;
12. Enter in the **Display** menu and adjust the Dynamic Range and the Reference Level to the most convenient visualization;
13. If the results are satisfactory select **Marker, Peak** and then either **Analyzer** or **Tune** to enter respectively in Spectrum Mode or in Manual Mode and deeply investigate the highest signals;
14. If the results of the scan need to be refined, select a **Limit**, if appropriate, and then **Measure, Level** and **Smart Detector** (if a limit has been loaded);
15. In the **Smart Detector** menu check the best combination among those listed; enter a **Margin**, if needed; press **Esc**;
16. **Exec Sweep** again and repeat from step #12.

4.1.5 Remarks and Hints for Measuring

To avoid errors caused by ambient interference, measurements should be carried out inside a properly shielded room. Different sites, like basements or other rooms with low ambient interferences, are often sufficient for a preliminary evaluation.

Conducted measurements do not strictly require any anechoic environment, while radiated tests may need it if so specified by the relevant standard.

Using the PMM Emission Suite SW running on an external PC it is possible to make automatic measurements and to automatically select LISNs lines (with the built-in LISN or any external PMM LISN), etc.

This page has been left blank intentionally

5 – Updating firmware and Activation code Utility

5.1 Introduction

The PMM 7010 features a simple and user-friendly method for updating its internal firmware through a Personal Computer (PC).

The “**WrDongle**” embedded in the FW Upgrade Tool is used for the **Options** activation procedure.

This section provides all the information required for easy updating.

5.2 System requirements

The minimum requirements to allow the software to operate properly are the following:

- 486 Processor or Pentium
- 16 Mb of RAM
- at least 10 Mb of free space on hard disk
- 1 free Serial Port (RS-232), or, alternatively, a USB/RS-232 Adapter with related driver
- Windows Operating System™ 98/2000/XP/Vista/Win7

5.3 Preparing the Hardware

Turn off the PMM 7010 and connect the RS-232 cable supplied with the apparatus directly or through a USB/RS-232 Adapter separately purchased (once related driver has been properly installed), to the 9 pin socket situated on the back panel of PMM 7010 on one side and to a free RS232 port (or USB in case of Adapter’s use) on the PC side.

The first free RS-232 port will be automatically detected by the Firmware Update Program during installation. In case of troubles please check port assignments on the PC through the Control Panel utility.

5.4 Software Installation

The Update Firmware and 7010 WrDongle executable programs are provided together with the 7010 Software Utility, burned on a CD-ROM and included in PMM 7010 Receiver package; anyway it’s always possible to check for newer releases and download them from official NARDA Italy Web Site Support page.



The User must have administrator privileges to install the 7010SeriesUp software in Windows 7; right click on the program .exe file and click on “Run as administrator” to temporarily run the program or application as an administrator until close it (Windows 7 also allows to mark an application so that it always runs with administrator rights).

Once the **7010SeriesUp Setup** has been installed in the PC, another item is created in the Programs list at Start Menu, which is “**PMM Emission Suite**”, from where the “**7010SeriesUp**” and “**WrDongle**” programs must be run from.

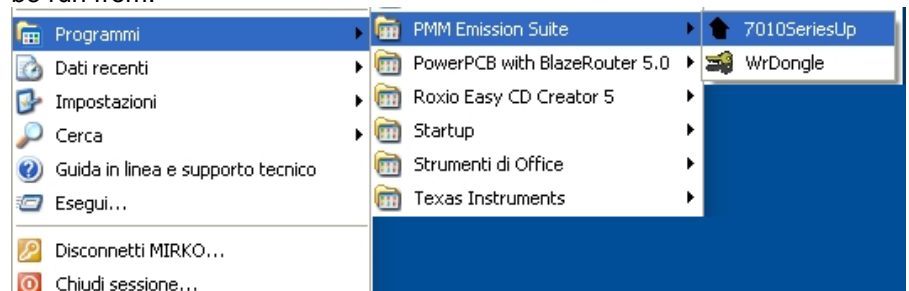

Click on “7010SeriesUp” (7010SeriesUp.exe) once for running the update program, so getting the following window:



Two firmware components can be updated by this application: Firmware, which is the receiver internal program, and FPGA, to update the internal programmable logic.

The **7010FW.ldr** file required for Firmware updating and the **main7010.bin** file for FPGA are automatically stored in the same directory of the **7010SeriesUp.exe**, otherwise just copy them there before performing the upgrade.

Be sure the power to the PMM 7010 is stable and reliable before performing the FW Upgrade, otherwise the upgrade progress could not terminate properly.



WARNING

Anyway, even in case of failure, the internal BIOS will never be corrupted and you'll just need to repeat the procedure once more (this is a unique feature!).

Should FW Upgrade procedure stop before reaching the 100% completion that will have not to be considered a trouble but simply an intermediate step: in this case please switch OFF and ON the receiver and repeat the FW Upgrade procedure once more until the end. Always cycle power OFF and ON again after every FW Upgrade.

Choose the COM port from the pulldown menu.



Press **RS232** button or **Enter** key to set the com port.

The program will display the following window:

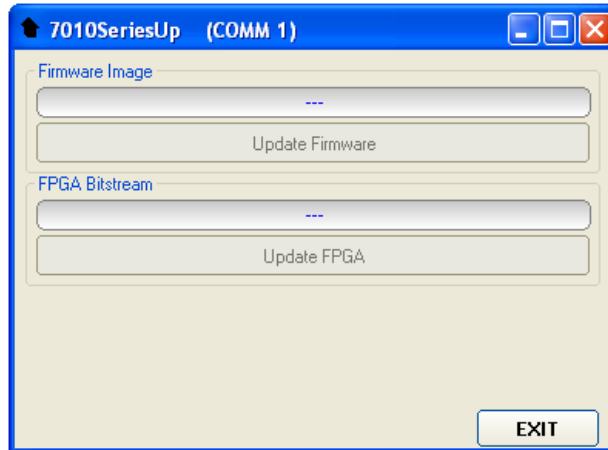

5.5 To transfer data

To start the process simply switch PMM 7010 on, select **Update Firmware** or **Update FPGA** button, and wait until the automatic transfer is completed.

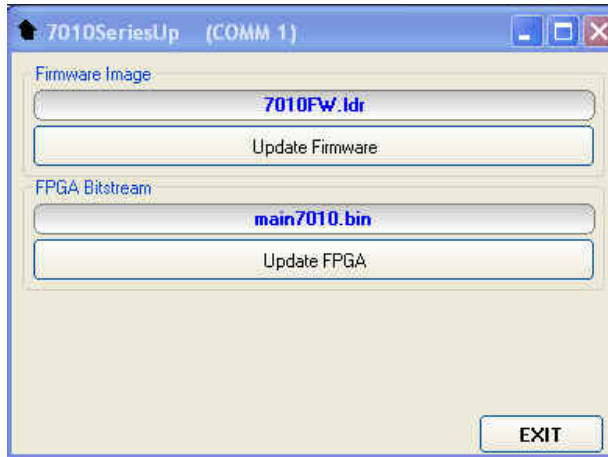

During the firmware storing procedure, a blue bar will progress from left to right in the window of the PC, showing percentage of downloading time by time until 100%.

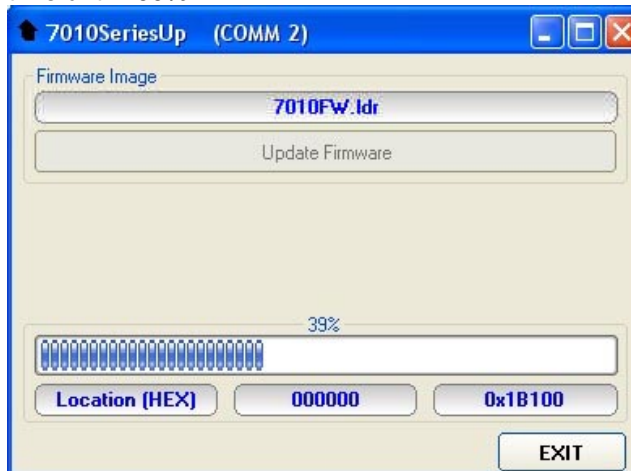

In the meanwhile on the 7010 front panel the DATA RX and TX led will blink to indicate a serial communication is going on.

When FW download finishes, following message appears to show that everything was properly completed:



The length of the file can change with the version.

In case of failure, an error message is showed instead.

After Firmware Update is successfully completed, switch OFF and then ON again the PMM 7010, looking at screen, and then perform Auto-calibration.

It is now possible to disconnect the cable connected to the PC, with the PMM 7010 receiver either switched On or Off.

 NOTE

To obtain up-to-date Firmware or PC Utility for PMM 7010, the user can contact his NARDA distributor or download it directly from Support area of EMC Product Range on the following Web Site: www.narda-sts.it.

5.6 7010 WrDongle utility

The **WrDongle** utility allows to enable the function ordered such Options using the **40 Digit Activation Code** received from NARDA Italy.

Turn on the PMM 7010 and connect it to a free USB or RS232 port of the PC.

Browse for All Programs from the Start Menu and reach the “**WrDongle**” executable link:

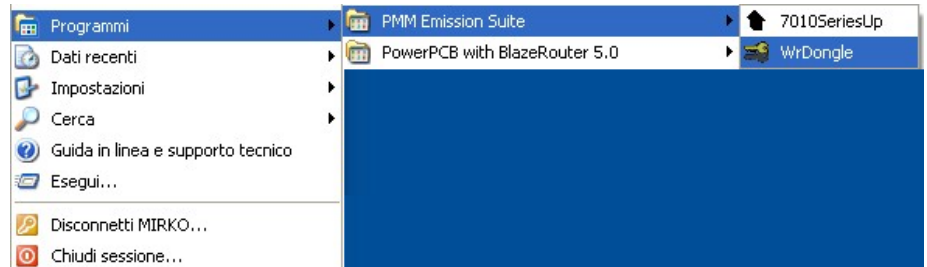

Main window displayed after the program **WrDongle** has been run:



Select **USB** or **RS232** communication port.

In case of RS232 communication, choose the COM port from the pulldown menu.

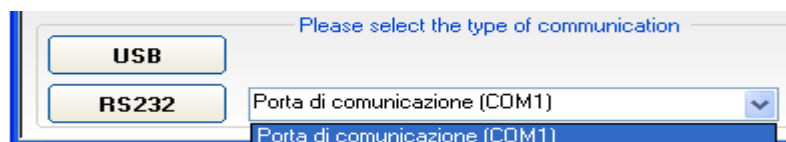

Press **RS232** button or **Enter** key to set the com port.

The program will display the following window:

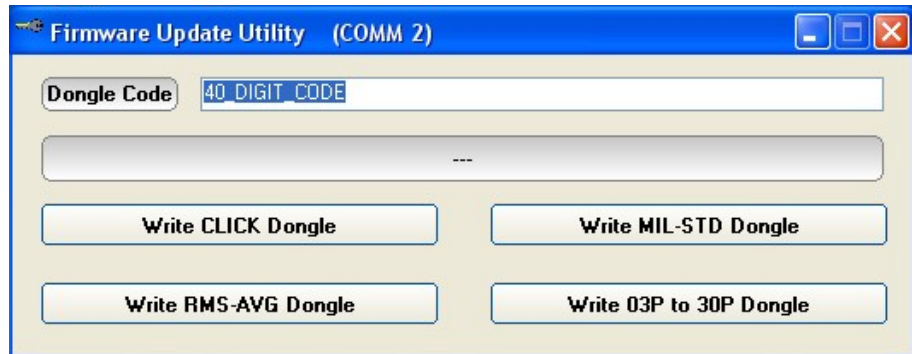

Copy and paste the **40 Digit Activation Code** to the “Dongle Code” input field and press the button below related to the specific Option:

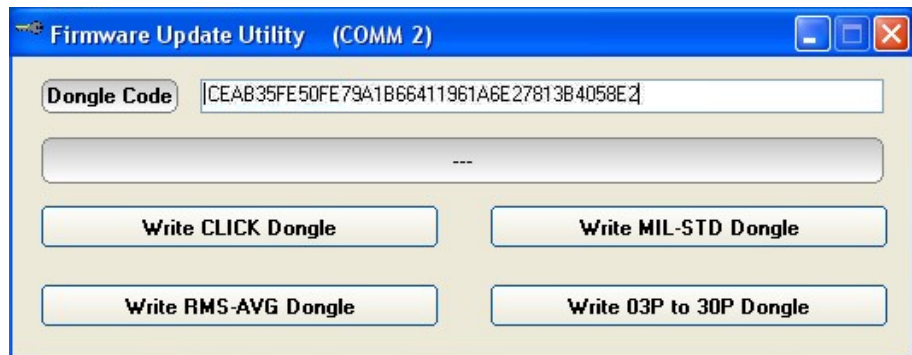

In case of failure, an error message is showed instead.

Always cycle OFF and ON the receiver to properly initialize the function.

 **NOTE**

With the PMM 7010 the only option available is the RMS-AVG standard CISPR detector.

For further information on activation procedure refer to the “RMS-AVG detector”.

6 – PMM 9010-RMA Rack Mount Adapter for Rack 19” (Option)



6.1 Introduction

A **19-inch rack** is a standardized frame or enclosure for mounting multiple equipment modules. Equipment designed to be placed in a rack is typically described as **rack-mount** or simply **chassis**; the height of the electronic modules is standardized as multiples of 1.75 inches (44.5 mm) or one rack unit or "U". Each module has a front panel that is 19 inches (482.6 mm) wide, including edges that protrude on each side which allow the module to be fastened to the rack frame with screws.

6.2 Instrument Items

PMM 9010-RMA Rack Mount Adapter includes the following items:

- Rack Mount kit (screws, plastic round washers and cage nuts).
- Return for Repair Form.

6.3 Optional accessories

PMM 9010-RMA Rack Mount Adapter can be used with several optional accessories, the most common being the following:

- PMM 9010 EMI Receiver 10 Hz ÷ 30 MHz;
- PMM 9010/03P EMI Receiver 10 Hz ÷ 300 MHz;
- PMM 9010/30P EMI Receiver 10 Hz ÷ 3 GHz;
- PMM 9010/60P EMI Receiver 10 Hz ÷ 6 GHz;
- PMM 7010 EMI Receiver 9 kHz ÷ 3 GHz

**6.4 PMM 9010-RMA
Main Specifications**

Table 6-1 lists the PMM 9010-RMA specifications.

TABLE 6-1 Technical Specifications	
Environment temperature	0° to 40°C
Rack unit	3U
Dimensions	483 x 410 x 132,5 mm (WxDxH)
Weight	5,5 Kg (without instruments)

6.5 PMM 9010-RMA Front view

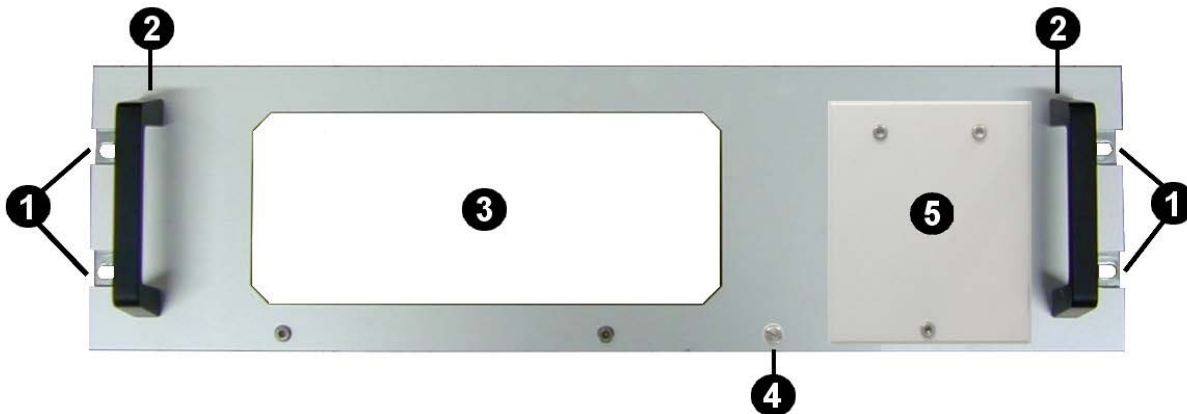

Fig. 6-1 Front view

Legend::

- 1 – Holes Flanges used to fix the Rack Mount to the Rack
- 2 – Handles used to carry the Rack Mount
- 3 – PMM 9010, 9010/03P/30P/60P or 7010 window
- 4 – Milled knob used to fix the frontal panel to the Rack
- 5 – Cover for future implementation

6.6 PMM 9010-RMA Inside view



Fig. 6-2 Inside view

Legend::

- **1** – Round holes of service
- **2** – Rectangular holes used to put 9010, 9010/03P/30P/60P or 7010 Instrument;
- **3** – 9010, 9010/03P/30P/60P or 7010 straps;
- **4** – Rectangular holes for future implementation;
- **5** – Straps for future implementation.

6.7 Rack Requirements The rack must be of the following type:

- Standard 19 inch (483 mm) with mounting rails that conform to English universal hole spacing per section 1 of ANSI/EIA-310-D-1992.
- The minimum vertical rack space per chassis must be 3U (rack units), equal to 3 inches (132,5 cm).

6.8 Required Equipment Before you begin the installation, ensure that you have the following items:

- Crosshead screwdriver (not provided)
- Flat-blade screwdriver or rack-insertion tool (not provided)
- Tape measure and level (not provided)
- Rack Mount kit (provided)

6.9 Moving chassis When lifting the chassis, be aware of its weight, and follow these guidelines:

- Disconnect all power and external cables before lifting the chassis.
- Remove all instruments from the chassis before lifting.

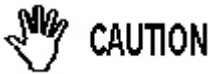

- **Make sure that the milled knob well locking.**
- Using the two handles, lift the PMM 9010-RMA slowly keeping your back straight. Lift with your legs, not with your back. Bend at the knees, not at the waist.

6.10 Installation guidelines

When installing the chassis, follow these guidelines:

- Plan your site configuration and prepare the site before installing the chassis.
- Ensure that there is adequate space around the rack to allow for servicing the chassis and for airflow.
- If the rack has wheels, ensure that the brakes are engaged or that the rack is otherwise stabilized



WARNING

- For a round hole (tapped) rack, use clip nuts with M6 x 16 screw (not provided).

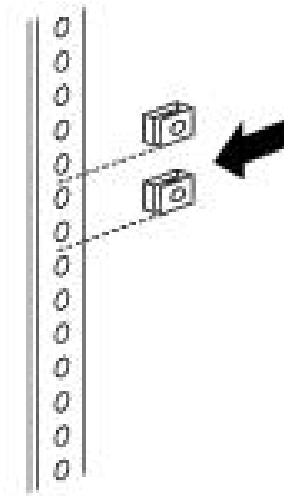

WARNING

- For a square hole (untapped) rack (shown below), use M6 x 16 screws, plastic round washers head screws and M6 cage nut (provided).



6.11 Installing the PMM 9010-RMA

This section describes how to install the PMM 9010-RMA Rack Mount Adapter:

- Insert the cage nuts behind the vertical rails with respect to the Rack Unit Boundary and the distance show below:

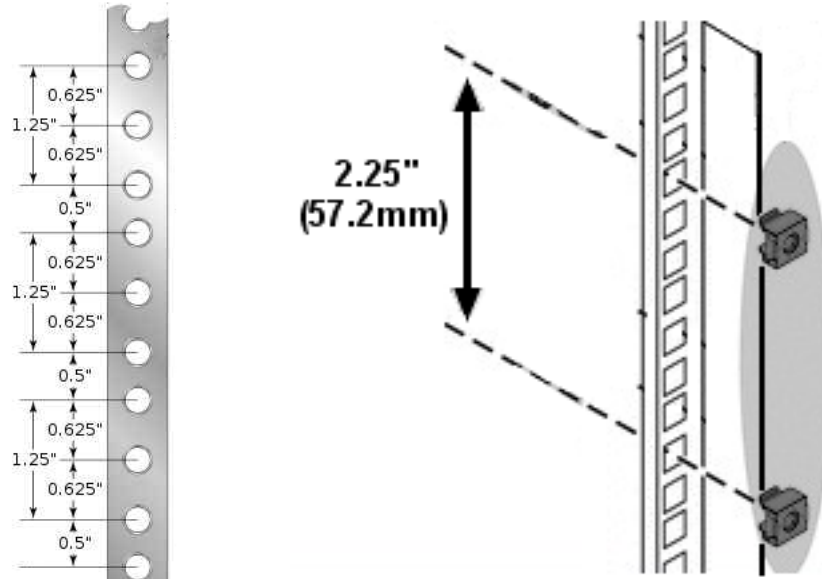

- You can use a rack-insertion tool or a flat-blade screwdriver to install the cage nuts.

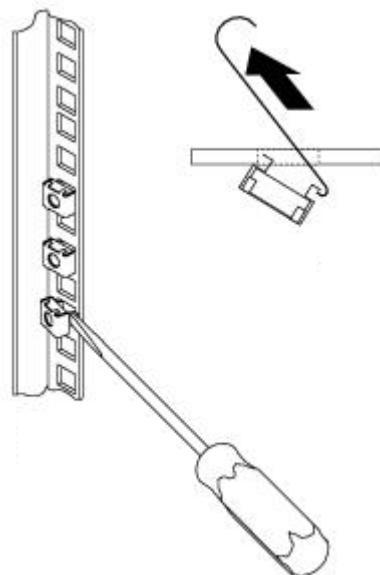

- Insert the chassis into the rack.
- Slide the chassis into the rack until the front flange is flat against the cage nuts.
- Using the four screws and black plastic washers, fix the chassis by its flanges to the rack.

**6.12 Use of the
PMM 9010-RMA
with
PMM 9010**

The following procedure is indifferently referred to the 9010, 9010/03P/30P/60P or 7010.

This section provides the information needed to install your 9010 or 7010 Instrument on the PMM 9010-RMA Rack Mount Adapter.

- Remove the frontal panel from the Rack unscrewing the milled knob without loosing it completely.
- Using the handles, open the PMM 9010-RMA slowly.
- Place the instrument by the rectangular holes and drag the instrument in contact with the frontal panel.
- To ensure the necessary stability, the instrument must be fastened to the unit using the straps.
- Connect the cables on the rear panel (see "Installation" chapter for further information)
- To fix the rear cables to the Rack Mount insert plastic straps by of the round holes.
- Using the handles, close the PMM 9010-RMA slowly.



Fig. 6-3 PMM 9010-RMA with 9010 Instrument

This page has been left blank intentionally

7 – Remote control

7.1 Introduction

PMM 7010 has been designed to allow remote control operations through its either RS232 or USB (Rear) ports.

When using RS232 you can use only one instrument connected to PC serial port. If using USB you can connect other instruments to the free RS232 port and the PMM 7010 Receiver to the USB 2.0.

PMM 7010 uses the same commands protocol for both communications.

7.2 Communication

Half duplex communication is implemented. The RS232 port has a DB-9 female connector and the USB 2.0 has a USB-B connector.

A built-in automatic tool identify the type of communication used.

The communication is at 115200 bit/sec with 8 bit words, one start bit, one stop bit and no parity

(115200 N 8 1).

7.3 Protocol

Be aware that only the PC can send the commands. PMM 7010 will answer when is inquired only.

The communication uses strings with variable byte width. The characters used inside the strings are in ASCII format (00 - 127) at 7 bits. The most significant bits are ignored in reception and set to 0 during transmission.

Every string starts with the special character “#” and stops with “*”.

7.4 Format

Commands are made of ASCII string delimited character “#” (0x23) and the character “*” (0x2A)

Replies are terminated with <CR><LF> (\r\n)



All the following examples are indifferently referred to the PMM 7010.

7.5 PMM 7010 COMMANDS Following are Commands to control and set various operating modes of PMM 7010, that can be distinguished in two main groups:

- Query Commands
- Setting Commands

7.5.1 Query COMMANDS

Query COMMANDS	
Command	Description
?IDN	This query command ?IDN* sends back a string containing information about model, release and date of firmware. Note that two <LF> are appended to the string before the terminator Example of reply: IDN=7010/03-FW - 1.09 11/06/14<LF><LF>
?S/N	This query command ?S/N* sends back a string containing serial number internally stored by manufacturer. Example of reply: S/N=000WE50327
?FPGA	This query command ?FPGA* sends back a string containing information about version of FPGA. Note that two <LF> are appended to the string before the terminator Example of reply: FPGA=0x14<LF><LF>
?UHT	This query command ?UHT* sends back a string expressing the actual hold time currently or lastly used Example of reply: UHT=1.9ms
?MAF	This query command ?MAF* sends back a string expressing the tuning frequency, in exponential notation, for manual mode. Unit is fixed MHz. Example of reply: MAF= 1.50000e+07 which means that the tuned frequency in manual mode is 15MHz
?MHT	This query command ?MHT* sends back a string expressing the HOLD TIME for manual mode. Unit is fixed ms. Example of reply: MHT= 1000 ms which means that the hold time in manual mode is 1000ms (or 1s)
?RBW	This query command ?RBW * sends back a string expressing the selected RBW. The reply is made of 3 fields: <ol style="list-style-type: none"> 1. RBW=AUTO (7010 automatically selects the suitable RBW according the tuned frequency) or RBW=MAN (Operator selects manually the RBW) 2. Id identify the RBW as follows: <ul style="list-style-type: none"> ○ 1 →300kHz ○ 2 →100kHz ○ 3 →30kHz ○ 4 →10kHz ○ 5 →3kHz ○ 6 →9kHz (Cispr 16-1) ○ 7 →200Hz (Cispr 16-1) (Option) ○ 8 →1kHz (Option) ○ Only for Radiated <ul style="list-style-type: none"> ▪ 10 →120kHz (Cispr 16-1) ▪ 9 →1MHz (Option) 3. RBW NickName (a mnemonic name) Example of reply: RBW=AUTO 6 (9k_CISPR) which means that selection is automatically made by 7010, the RBW id is 6 (9kHz (Cispr 16-1)). (9k_CISPR) is the nickname to quickly identify it

?CRA	<p>This query command #?CRA* sends back a string telling whether RMS-AVG detector is available. Reply is:</p> <ul style="list-style-type: none"> • CRA=N/A if RMS-AVG detector is NOT available • CRA=OK if RMS-AVG detector is available
?DET	<p>This query command #?DET* sends back a string reporting the six detector for manual mode. Unit is fixed dBμV. Each value is separated by a semicolon. The order is Peak; Qpeak; RMS;AVG;C-RMS:C-AVG In case Qpeak is not available (RBW other than 9kHz [only for Band B] ,120kHz) Qpeak field is replaced by the string "----". In case C-RMS or C-AVG is not available (RBW other than 9kHz,120kHz) respective field is replaced by the string "----".</p> <p>An additional string "OVER;" is appended at the end whenever an over range condition occurred Example of reply: DET=23.22;17.09;16.23;11.36,16.01,15.50; (which means Peak=23.22; Qpeak=17.09; RMS=16.23;AVG=11.36;C-RMS=16.01;C-Avg=15.50) Example of reply (No Cispr filter selected, over range shown): DET=17.20;-----;11.98;9.57;-----;-----;OVER;</p>
?TAT	<p>This query command #?TAT * sends back a string expressing MinAtt value. The reply is a string representing the minimum reachable value of attenuator in dB Example of reply: TAT=10 which means that MinAtt is 10dB</p>
?MAT	<p>This query command #?MAT * sends back a string expressing the Attenuator status for Manual mode. The reply is made of 2 fields:</p> <ul style="list-style-type: none"> • MAT=AUTO (7010 automatically selects the most suitable attenuator to get best dynamic range) or MAT=MAN (the operator selects manually the attenuator) • Value (in dB) of current attenuator <p>Example of reply: MAT=AUTO; 20 which means that the Attenuator is now switched to 20dB automatically by 7010</p>
?3PR	<p>This query command #?3PR * sends back a string expressing whether the apparatus is a PMM 7010 and in which mode. The reply is either:</p> <ul style="list-style-type: none"> • 3PR =CON (The PMM 7010 is ready for conducted frequency range) • 3PR =RAD (The PMM 7010 is ready for radiated frequency range) • 3PR=NUL (The PMM 7010 is not ready)
?DMD	<p>This query command #?DMD * sends back a string expressing the status of demodulator. The reply is either:</p> <ul style="list-style-type: none"> • DMD=Off (The Demodulator is OFF) • DMD =AM (The Demodulator is On and demodulating AM) • DMD =FM (The Demodulator is On and demodulating FM)
?DMV	<p>This query command #?DMV * sends back a string expressing the volume of demodulator. The reply is made of the string "DMV=" followed by the magnitude of volume ranging from 0 to 100</p> <ul style="list-style-type: none"> • DMV=50 (The Demodulator Volume is 50)
?ART	<p>This query command #?ART* sends back a string expressing the Start frequency, in exponential notation, for analyzer mode. Unit is fixed MHz. Example of reply: ART = 1.500000e+07 which means that the start frequency in Analyzer mode is 15MHz</p>
?AOP	<p>This query command #?AOP* sends back a string expressing the Stop frequency, in exponential notation, for analyzer mode. Unit is fixed MHz. Example of reply: AOP = 3.000000e+07 which means that the Stop frequency in Analyzer mode is 30MHz</p>

?ACE	<p>This query command #?ACE* sends back a string expressing the Center frequency, in exponential notation, for analyzer mode. Unit is fixed MHz. Example of reply: ACE = 1.500000e+07 which means that the Center frequency in Analyzer mode is 15MHz</p>
?ASP	<p>This query command #?ASP* sends back a string expressing the Spanfrequency, in exponential notation, for analyzer mode. Unit is fixed MHz. Example of reply: ASP = 3.000000e+07 which means that the Span frequency in Analyzer mode is 30MHz</p>
?AAT	<p>This query command #?AAT * sends back a string expressing the Attenuator status for Analyzer mode. The reply is made of 2 fields:</p> <ul style="list-style-type: none"> • AAT =AUTO (7010 automatically selects the most suitable attenuator to get best dynamic range) or AAT =MAN (operator selects manually the attenuator) • Value (in dB) of current attenuator <p>Example of reply: AAT =AUTO; 20 which means that the Attenuator is now switched to 20dB automatically by 7010</p>
?ADT	<p>This query command #?ADT * sends back a string expressing the detector used for Analyzer mode. The reply can be:</p> <ul style="list-style-type: none"> • ADT =Peak • ADT =Avg • ADT =Rms
?AHT	<p>This query command #?AHT* sends back a string expressing the HOLD TIME for Analyzer mode. Unit is fixed ms. Example of reply: AHT= 1000 ms which means that the hold time in Analyzer mode is 1000ms (or 1s)</p>
?UPP	<p>This query command #?UPP* sends back a string expressing the status of input PIN of the User Port.</p> <p>Example of reply: UPP= 1 means that user port pin is high level</p>
?CFA	<p>This query command #?CFA* sends back a string in the format CFA=n,(LABEL) where n is the ID of the conversion factor as shown in 7010 menu and LABEL is its temporary name as it was last labelled. If No conversion factor is active the reply is: CFA= NONE</p> <p>Example of reply: CFA=1,(PROBE) means that conversion factor 1 is active and it was last named as PROBE</p>
?LSN	<p>This query command #?LSN* sends back a string showing which Band B input is selected in the format: LSN=n Where n can be:</p> <ul style="list-style-type: none"> • 0 → Input on N connector • 1 → Input on 7010 internal LISN L1 • 2 → Input on 7010 internal LISN L2 <p>Example of reply: LSN=0</p>
?TMP	<p>This query command #?TMP* sends back a string showing the temperature expressed in <u>Celsius</u> (°C) .</p> <p>Example of reply: TMP= 40.50</p>

7.5.2 SETTING Commands

Setting COMMANDS	
Command	Behaviour
SLSN n	<p>This setting command #SLSN n* sets the input for Band B according to the argument 'n' as follows:</p> <ul style="list-style-type: none"> • 0 → Input on N connector • 1 → Input on 7010 internal LISN L1 • 2 → Input on 7010 internal LISN L2 <p>'n' higher than '2' is ignored and SERR message sent back</p> <p>The reply is LSN =OK which acknowledges the command has been granted or LSN =SERR if the command has been ignored. Example: #SLSN 0* switches the input for radiated to 'N' connector Example: #SLSN 2* switches the input for radiated to the 7010 built-in LISN Line-2</p>
SMAF f	<p>This setting command sets the tuning frequency for manual mode. The string (f) can be in exponential form and should be expressed in Hz. The reply is MAF=OK which acknowledges the command has been granted or MAF=SERR if the command has been ignored. When the command is granted the 7010 goes to manual mode automatically Example: #SMAF150e3* Sets the manual frequency to 150kHz</p>
SMHT h	<p>This setting command sets hold time for manual mode. The string (h) should be expressed in ms. The reply is MHT=OK which acknowledges the command has been granted or MHT=SERR if the command has been ignored. When the command is granted the 7010 goes to manual mode automatically. Example: #SMHT 1500* Sets the hold time, for manual mode, to 1500 ms (or 1.5s)</p>
SRBW b	<p>This setting command sets RBW. The argument (b) should be a string representing the RBW as follows:</p> <ul style="list-style-type: none"> ○ 0 →RBW is Automatic so that the 7010 automatically selects the suitable RBW according to the tuned frequency ○ 1 →300kHz ○ 2 →100kHz ○ 3 →30kHz ○ 4 →10kHz ○ 5 →3kHz ○ 6 →9kHz (Cispr 16-1) ○ 7 →200Hz (Cispr 16-1) (Option) ○ 8 →1kHz (Option) ○ Only for Radiated <ul style="list-style-type: none"> ▪ 10 →120kHz (Cispr 16-1) ▪ 9 →1MHz (Option) <p>The reply is RBW =OK which acknowledges the command has been granted or RBW =SERR if the command has been ignored. Example: #S RBW 3* sets the RBW to 30kHz and disables Auto RBW mode Example: #S RBW 0* turn the RBW mode in Automatic</p>
SMAN	<p>This setting command puts the 7010 in manual mode. The reply is always MAN=OK which acknowledges the command has been granted. The 7010 goes to manual mode. Example: #SMAN *</p>

SMANP	<p>This setting command puts the 7010 in manual mode and sets the default value to the following settings:</p> <ul style="list-style-type: none"> • RBW Automatic • Attenuator Automatic • MinAtt=10 dB • Preselector On • Preamplifier OFF • Hold Time =1000ms • Pulse Limiter = OFF • TG=OFF <p>The reply is always MANP=OK which acknowledges the command has been granted. The 7010 goes to manual mode. Example: #SMANP*</p>
STAT b	<p>This setting command sets MinAtt to the value indicated by (b) which range from 0dB to the maximum the 7010 can set and must be in step of 5dB. The reply is TAT=OK which acknowledges the command has been granted or TAT =SERR if the command has been ignored. Example: #STAT 10*</p>
SMAT a	<p>This setting command sets Attenuator, for Manual Mode, to the value indicated by (a) which can be 0 to 35 (55). Automatic Attenuator feature is disabled. If (a) is a negative figure then the Automatic Attenuator feature is turned on. The reply is MAT=OK which acknowledges the command has been granted or MAT =SERR if the command has been ignored. When the command is granted the 7010 goes to manual mode automatically. Example: #SMAT 15* (set attenuator to 15dB and disable Automatic Attenuator feature) Example: #SMAT -1* (Enable Automatic Attenuator feature)</p>
SDMD	<p>This setting command switches the Demodulator; according the parameter (a) which can be AM, FM or OFF. The reply is DMD =OK which acknowledges the command has been granted or DMD =SERR if the command has been ignored. Example: # DMD FM* Example: # DMD OFF*</p>
SDMV v	<p>This setting command sets the volume of demodulator. The string (v) should be in the range of 0 to 100. The reply is DMV =OK which acknowledges the command has been granted or DMV =SERR if the command has been ignored. Example: #SDMV 50* Sets the volume of demodulator to half of the audio power.</p>

SAFF start,stop	<p>This setting command sets both Start and Stop frequency for Analyzer mode. The strings (Start and Stop) can be in exponential form and should be expressed in Hz. The reply is AFF=OK which acknowledges the command has been granted or AFF =SERR if the command has been ignored.</p> <p>Example: #SAFF 150e3,30e6* Sets the Start frequency to 150kHz and Stop frequency to 30MHz for Analyzer mode</p>
SART f	<p>This setting command sets the Start frequency for Analyzer mode. The string (f) can be in exponential form and should be expressed in Hz. The reply is ART=OK which acknowledges the command has been granted or ART =SERR if the command has been ignored.</p> <p>Example: #SART 150e3* Sets the Start frequency, for Analyzer mode, to 150kHz</p>
SAOP f	<p>This setting command sets the Stop frequency for Analyzer mode. The string (f) can be in exponential form and should be expressed in Hz. The reply is AOP=OK which acknowledges the command has been granted or AOP =SERR if the command has been ignored.</p> <p>Example: #SAOP 10e6* Sets the Stop frequency, for Analyzer mode, to 10MHz</p>
SAAT a	<p>This setting command sets Attenuator, for Analyzer Mode, to the value indicated by (a) which can be 0 to 35 (55). Automatic Attenuator feature is disabled. If (a) is a negative figure then the Automatic Attenuator feature is turned on. The reply is AAT=OK which acknowledges the command has been granted or AAT =SERR if the command has been ignored.</p> <p>Example: # AAT 15* (set attenuator to 15dB and disable Automatic Attenuator feature) Example: # AAT -1* (Enable Automatic Attenuator feature)</p>
SADT b	<p>This setting command sets the detector for Analyzer Mode. The argument (b) should be a index representing the detector as follows:</p> <ul style="list-style-type: none"> ○ 1 →Peak ○ 2 →Avg ○ 3 →Rms <p>The reply is SADT =OK which acknowledges the command has been granted or SADT =SERR if the command has been ignored. Example: # SADT 1* sets the detector to Peak for Analyzer Mode</p>
SAHT h	<p>This setting command sets hold time for Analyzer mode. The string (h) should be expressed in ms. The reply is AHT=OK which acknowledges the command has been granted or AHT =SERR if the command has been ignored. Example: #S AHT 1500* Sets the hold time, for Analyzer mode, to 1500 ms (or 1.5s)</p>

SAGO	<p>This setting command puts the 7010 in Analyzer mode. The reply is always SAGO=OK, which acknowledges the command has been granted, followed by an array, variable in size, representing the reply. Please refer to “Analyzer Reply” section for details of the response. The 7010 goes to Analyzer mode.</p> <p>The 7010 goes to Analyzer mode. Example: #SAGO*</p>
SSTP	<p>This setting command stops abruptly a running sweep in Analyzer mode. The reply is always STP=OK, which acknowledges the command has been granted</p>
SLIM n	<p>This setting command sets the Margin to be used with Smart Detector function. The argument (n) in the range of -20 to 20. The reply is LIM =OK which acknowledges the command has been granted or LIM =SERR if the command has been ignored. Example: #SLIM 2* Sets the threshold of smart detector to 2 dB below the limit.</p>
SLIW n,freq;lev	<p>This setting command is used for setting the custom limit frequency by frequency. It consists of three fields as follows:</p> <ul style="list-style-type: none"> • n Is the index of frequency being written and it should range from 0 to 15 • freq Is the frequency, expressed in Hz (exponential notation allowed), being written • lev Is the level of the limit and is expressed in dBμV <p>The procedure to set a custom limit on PMM7010 is the following:</p> <ul style="list-style-type: none"> • Send as many commands as the frequency points of limit are in upwards order. • Terminate (and make it active) by sending the command SLIE <p>Here is an example how to make a custom limit on PMM7010:</p> <ul style="list-style-type: none"> • #SLIW 0, 150e3; 66 * Send the first line 150kHz 66 dBμV • #SLIW 1, 500e3; 56 * Send the second line 500kHz 56 dBμV • #SLIW 2, 5e6; 56 * Send the third line 5MHz 56 dBμV • #SLIW 3, 5e6; 60 * Send the fourth line 5MHz 60 dBμV • #SLIW 4, 30e6; 60 * Send the fifth line 30MHz 60 dBμV <ul style="list-style-type: none"> • #SLIE Custom CISPR 14-1 * Send the name and make the limit active <p>Note that all the higher indexes in the limit are cleared. Therefore, a limit must be made in upwards order otherwise all points, having a higher index previously written, are cleared. It is responsibility of the user to make sure the data sent are correct and coherent.</p> <p>The reply is SLIW =OK which acknowledges the command has been granted or LIW =SERR if the command has been ignored.</p>

<p>SLDW n,freq; levq,leva</p>	<p>This setting command is used for setting the custom double value limit frequency by frequency. It consists of four fields as follows:</p> <ul style="list-style-type: none"> • n Is the index of frequency being written and it should range from 0 to 15 • freq Is the frequency, expressed in Hz (exponential notation allowed), being written • levq Is the level of the limit which refers to QPeak and is expressed in dBμV • leva Is the level of the limit which refers to the alternate detector and is expressed in dBμV <p>The purpose of this command is to have a double value limit that can be used along with smart detector function when sweeping by the command SSFD:</p> <p>The procedure to set a custom double value limit on PMM7010 is the following:</p> <ul style="list-style-type: none"> • Send as many commands as the frequency points of limit are in upwards order. • Terminate (and make it active) by sending the command SLIE <p>Here is an example how to make a custom limit on PMM7010:</p> <ul style="list-style-type: none"> • #SLDW 0, 150e3; 66,56 * Send the first line 150kHz 66 dBμV • #SLDW 1, 500e3; 56,46 * Send the second line 500kHz 56 dBμV • #SLDW 2, 5e6; 56,46 * Send the third line 5MHz 56 dBμV • #SLDW 3, 5e6; 60,50 * Send the fourth line 5MHz 60 dBμV • #SLDW 4, 30e6; 60,50 * Send the fifth line 30MHz 60 dBμV • #SLIE Custom Double * Send the name and make the limit active <p>Note that all the higher indexes in the limit are cleared. Therefore, a limit must be made in upwards order otherwise all points, having a higher index previously written, are cleared.</p> <p>It is responsibility of the user to make sure the data sent are correct and coherent.</p> <p>The reply is SLDW =OK which acknowledges the command has been granted or LDW =SERR if the command has been ignored.</p>
<p>SLIE name</p>	<p>This setting command is used for naming the custom limit and making it active or deactivating it. The command is made of the string LIE (the command itself) and a string which represents the name of the limit it will be shown. Sending a LIE with no argument (Limit name) deactivates all limit active, if any. This command is intended for making a custom limit into PMM7010. For further information see command SLIW.</p> <p>When the command is received the limit is checked and, if data (frequency and level) are coherent, the command is granted by replying SLIW =OK otherwise the replay is SLIW =SERR</p> <p>Example: # SLIE Custom Limit* checks the data previously loaded by SLIW commands, names the limit as "Custom Limit" and activates it</p> <p>Example: # SLIE * deactivates any limits</p>

<p>SSFW n,freq</p>	<p>This setting command is used for creating a Frequency-Scan-Tab frequency by frequency. It is made of two fields as follows:</p> <ul style="list-style-type: none"> • n Is the index of frequency being written and it should range from 0 to 99 • freq Is the frequency, expressed in Hz (exponential notation allowed), being written <p>The procedure to make and use a Frequency-Scan-Tab on PMM7010 is the following:</p> <ul style="list-style-type: none"> • Send as many commands SSFW as frequency points of table are in upwards order. • Send the command SSFD with step size set to zero <p>Here is an example how to make a Frequency-Scan-Tab on PMM7010:</p> <ul style="list-style-type: none"> • #SSFW 0, 150e3 * Set the first freq to 150kHz • # SSFW 1, 500e3 * Set the second freq to 500kHz • # SSFW 2, 5e6* Set the third freq to 5MHz • # SSFW 3, 6e6* Set the fourth freq to 6MHz • # SSFW 4, 30e6 * Set the fifth freq to 30MHz <p>Note that all the higher indexes in the Frequency-Scan-Tab are cleared. Therefore, a Frequency-Scan-Table must be made in upwards order. All points, having a higher index previously written, are cleared.</p> <p>Note that only the present frequencies will be tuned and measured as all remaining will be completely neglected. Hence, it is responsibility of the user to make sure the data sent are correct and coherent.</p> <p>The reply is SSFW =OK which acknowledges the command has been granted or SSFW =SERR if the command has been ignored.</p>
<p>SSFD FreqStart; FreqStop; FreqStep; Detector; HoldTime; Rbw; MinAtt; Preamp; Preselector; ScanHoldT</p>	<p>Arguments are as follows:</p> <ul style="list-style-type: none"> • FreqStart = Sweep Start Frequency expressed in Hz • FreqStop = Sweep Stop Frequency expressed in Hz • FreqStep = Sweep Step Frequency expressed in Hz <ul style="list-style-type: none"> ○ If FreqStep > 0 then a standard sweep, tuned step by step, is made ○ If FreqStep = 0 then the sweep will be made by tuning all the frequencies which are listed in Frequency-Scan-Tab (which it must have been written previously by command SSFW). • Detector. In non –smart mode, any combination of the following detectors can be used and combined. All the detectors set will be measured and sent out. However, in Smart Mode only one detector at time, in addition to PEAK which is always present, can be set. <ul style="list-style-type: none"> ○ Non Smart Mode (All detectors can be indicated at once). Order is not important. <ul style="list-style-type: none"> ▪ P →Peak ▪ Q Peak ▪ N C-Rms ▪ A →Avg ▪ R →Rms ▪ C →C-Avg ○ Smart Mode (No more than 2 detectors can be indicated at once) <ul style="list-style-type: none"> ▪ S → Smart Mode (this must be the first in the string) ▪ Q Peak ▪ N C-Rms ▪ A →Avg ▪ R →Rms ▪ C →C-Avg

(Continued)

SSFD FreqStart;
FreqStop;
FreqStep;
Detector;
HoldTime; Rbw;
MinAtt; Preamp;
Preselector;
ScanHoldT

- **HoldTime** = Hold Time for each step and it is expressed in ms. Note that in case of Smart Mode HoldTime is used only when the disturbance is measured again by the alternative detector as minimum time, depending on the Rbw set, is used for the fast scan.
- **Rbw**. This is the index of Rbw to be used for the scan. Neither automatic selection, nor automatic switch is performed. The user must issue a suitable Rbw index. Index are as follows:
 - 1 →300kHz
 - 2 →100kHz
 - 3 →30kHz
 - 4 →10kHz
 - 5 →3kHz
 - 6 →9kHz (Cispr 16-1)
 - 7 →200Hz (Cispr 16-1) (Option)
 - 8 →1kHz (Option)
 - Only for Radiated
 - 10 →120kHz (Cispr 16-1)
 - 9→1MHz (Option)
- **MinAtt** = Minimum attenuation allowed during sweeping. This parameter ranges from 0 (no limitation) to the maximum the 7010 can set. This parameter is normally used to avoid switching up the sensitivity in order to either protect the input from high spikes or to prevent switching down the attenuation when, for instance, the limit is so high that it would be only waste of time.
- **Preamp**. This Parameter switches the Preamplifier On or Off according to its content as follows.
 - **On**. It turns ON the preamplifier.
 - **Off**. It turns Off the preamplifier.
- **Preselector**. This Parameter switches the Preselector On or Off according to its content as follows.
 - **On**. It turns ON the Preselector.
 - **Off**. It turns Off the Preselector.
- **ScanHoldT** = Hold Time used in Smart Mode when tuning for Peak for each step and it is expressed in ms. Note that this is used only in case of Smart Mode and not in standard sweep. This parameter is not compulsory and can be omitted if not required. In case it is not present, minimum time is taken.

This command triggers a free sweep (no automatic items are selected) based on the provided parameters. After this command has been received, all parameters issued in the command itself are checked out and, if coherent, a sweep starts otherwise the related error is notified and the sweep is not triggered.

Moreover, using the Frequency-Scan-Tab, the user has the capability of tuning only those frequencies which are suspected skipping thus the remainder. Hence, saving a lot of time.

After the command has been received, the 7010 replies by sending a string which reflects the status of parameter check as follows:

- **SFD=OK<RC><LF>** No error in parameters and sweep started.
- **SFD=ERR 1<RC><LF>** An Error was found in **start** or **stop** frequencies. Errors can be one of the following:
 - Start Frequency lower than minimum allowed frequency
 - Stop Frequency higher than maximum allowed frequency
 - Start Frequency higher than Stop Frequency
- **SFD=ERR 2<RC><LF>** An Error was found in **step** frequency. Step is either
 - Too small.
 - Is equal to zero (use of Frequency-Scan-Tab) but there are less than

(Continued)

SSFD FreqStart;
FreqStop;
FreqStep;
Detector;
HoldTime; Rbw;
MinAtt; Preamp;
Preselector;
ScanHoldT

two frequencies in the table

- **SFD=ERR 3<RC><LF>** An Error was found in **detector**. Errors can be one of the following:
 - Invalid Detector or no detector found. Detectors must be indicated by 'P', 'Q', 'R', 'A', 'N' and 'S' only
 - Smart Mode selected but no active limit
 - Smart Mode selected but no alternative detector
 - Smart Mode selected but more than two alternative detector indicated
- **SFD=ERR 4<RC><LF>** An Error was found in **HoldTime** value. **HoldTime** is either too big (>10s) or negative.
- **SFD=ERR 5<RC><LF>** An Error was found in **RBW**. Errors can be one of the following:
 - Unsuitable RBW for the active unit (for instance 200HZ Rbw while Downconverter is active)
 - Unsuitable RBW for the detector previously selected (for instance 100kHz Rbw and QuasiPeak selected).
- **SFD=ERR 6<RC><LF>** An Error was found in **MinAtt** value. Errors can be one of the following:
 - **MinAtt** value is negative
 - **MinAtt** value is higher than maximum available attenuation
 - **MinAtt** value is not in step of 5
- **SFD=ERR 7<RC><LF>** An Error was found in **Preamp** string. **Preamp** string can be either **ON** or **OFF** only. String is not case sensitive.
- **SFD=ERR 8<RC><LF>** An Error was found in **Preselector** string. **Preselector** string can be either **ON** or **OFF** only. String is not case sensitive.

Once the sweep is started, the 7010 sends the value of each detector chosen in the command. Each detector is made of a Little Endian 16 bit integer which represents the value of that particularly tuned frequency. The value is expressed in **hundredth of dBm**. Therefore, for each step, there will be a packet of **n** detectors (**n *2** bytes). The order of detectors is fixed and is not related to the order issued in the command. For instance, PAQ is equivalent to QAP as well as RA is same as AR. The order of detector is as follows (from the first to the last):

1. Peak (which is always present)
2. QPeak (QuasiPeak)
3. RMS
4. AVG (Average)
5. C-RMS
6. C-AVG

Special meaning has the value **NOLEVEL, -32700** (Hex 8044), which informs that the detector has not been measured. This happens, for example, in Smart mode where the alternative detector is taken only for those frequencies the Peak was above the limit.

After having terminated all steps and sent all data, the string **SFD_END<RC><LF>** is then sent informing the user there are no more data left.

Any started sweep can be stopped by sending the command **ASBK** which abruptly terminates it.

In case the sweep was prematurely terminated by the command **ASBK**, the end of sweep (which will not contain all expected data) is **SBK=OK<RC><LF>**

<p>(Continued)</p> <p>SSFD FreqStart; FreqStop; FreqStep; Detector; HoldTime; Rbw; MinAtt; Preamp; Preselector; ScanHoldT</p>	<p>Here is an example of the command: #SSFD 1e6;10e6;10e3;PAR;0;6;10;OFF;ON* Which triggers a sweep from 1 MHz to 10 MHz using a step of 5 kHz. Detectors are Peak, AVG and RMS. The hold time will be the minimum suitable (automatically adjusted by the unit). RBW is 9kHz. MinAtt is 10 dB which means that the attenuator will not switch below 10 dB attenuation. Preamplifier is OFF while the Preselector is turned on. Here, for each step there will be a packet of 3 detectors per step (Peak, AVG and RMS in this order) counting thus 6 bytes (3 * 2) per step.</p> <p>Here is another example: #SSFD 9e3;150e3;50;SPQ;1000;7;10;OFF;ON;100* Which triggers a sweep from 9kHz to 150kHz using a step of 50 Hz. Detector is Smart QuasiPeak using a hold time of 1s in re-measuring those frequencies which value was over the limit scanned using 100ms holdtime . RBW is 200Hz. MinAtt is 10 dB which means that the attenuator will not switch below 10 dB attenuation. Preamplifier is OFF while the Preselector is turned on. In this case, as all the needed conditions are matched , FFT is used to perform the Peak scan. Here, for each step there will be a packet of 2 detectors per step (Peak and QuasiPeak in this order) counting thus 4 bytes (2 * 2) per step. Of course, most of QuasiPeak value will be populated by NOLEVEL as QuasiPeak will be measured only for few frequencies (the ones which value is above the limit).</p>
<p>SCFW n,freq;lev</p>	<p>This setting command is used for creating a conversion factor frequency by frequency. It consists of three fields as follows:</p> <ul style="list-style-type: none"> • n Is the index of frequency being written and it should range from 0 to 499 • freq Is the frequency, expressed in Hz (exponential notation allowed), being written • lev Is the level of the limit and is expressed in dB <p>The procedure to creating a conversion factor on PMM7010 is the following:</p> <ul style="list-style-type: none"> • Send as many commands as the frequency points of limit are in upwards order. • Terminate (and make it active) by sending the command SFCE <p>Here is an example how to make a custom limit on PMM7010:</p> <ul style="list-style-type: none"> • #SCFW 0, 150e3; -1 * Send the first line 150kHz -1 dB • # SCFW 1, 500e3; 0 * Send the second line 500kHz 0 dB • # SCFW 2, 5e6; 1.2 * Send the third line 5MHz +2 dB • # SCFW 3, 50e6; 1.1 * Send the fourth line 50MHz +1.1 dB • # SCFW 4, 300e6; 1 * Send the fifth line 300MHz +1 dB <ul style="list-style-type: none"> • #SCFE 2,Probe* Save it permanently as #2 into 7010 and name it as "PROBE" <p>Note that all the higher indexes in the conversion factor are cleared. Therefore, a conversion factor must be made upwards otherwise all points, having a higher index previously written, are cleared. It is responsibility of the user to make sure the data sent are correct and coherent.</p> <p>The reply is SCFW =OK which acknowledges the command has been granted or LCFW =SERR if the command has been ignored.</p>

SCFE n, name	<p>This setting command is used for saving the conversion factor (made by SCFW). The command is made of the string:</p> <ul style="list-style-type: none"> • FCE (the command itself), • n is the index and should be 0 (other index are ignored) • name which is a string representing the name of it <p>This command is intended for creating a conversion factor into PMM7010. For further information see command SCFW. When the command is received the conversion factor is checked and, if data (frequency and level) are coherent, the command is granted by replying SCFW =OK otherwise the replay is SCFW =SERR</p> <p>Example: #SCFE 0,Probe* checks the data previously loaded by SCFW commands, names it as "Probe" and activates it.</p>
SCFA	<p>This setting command deactivates the conversion factor (if any). The reply is: CFA=OK (OFF)</p>
ASBK	<p>This command aborts a sweep currently in progress previously started by command SSFD. The reply is either:</p> <ul style="list-style-type: none"> • SBK=OK which means the sweep has been stopped and all setting commands are available again. • SBK=SERR which informs that the sweep was not in need to be stopped
ASPA	<p>This command suspends a sweep currently in progress previously started by command SSFD. There is no reply unless a sweep is not in progress in which case the reply is:</p> <ul style="list-style-type: none"> • SPA=SERR which informs that the sweep was not in need to be paused
ASRE	<p>This command resumes a sweep previously paused by command ASPA. There is no reply unless a sweep is not in progress in which case the reply is:</p> <ul style="list-style-type: none"> • SRE=SERR which informs that the sweep was not in need to be resumed
SUPP n	<p>This setting command #SUPP n* outputs on the User Port bit by bit the argument n . Each Pin has its own contribution according to its index as follows:</p> <p>OUT0= 2⁰ OUT1= 2¹ OUT2= 2²</p> <p>Thus, the argument sent is the sum of each weighted contribution The reply is UPP=OK which acknowledges the command has been granted or UPP=SERR if the command has been ignored (IE argument >31).</p> <p>Example: SUPP 5 will set:</p> <ul style="list-style-type: none"> • user port pins OUT0 and OUT2 to high level • user port pins OUT1 to low level

S3PRC	<p>This setting command #S3PRC * sets the PMM 7010 to conducted mode (BAND B). The reply is:</p> <ul style="list-style-type: none"> • 3PR=OK (The PMM 7010 has been set for conducted mode) • 3PR =BERR (The command has been ignored for the following: <ul style="list-style-type: none"> • The instrument is not idling and therefore cannot switch to a different mode. In such an event, stop the current process (Manual, Analyzer or Sweep) and put it back to Idle. • 3PR =SERR (The command contains a syntax error)
S3PRR	<p>This setting command #S3PRR * sets the PMM 7010 to radiated mode (BANDS C, D and E). The reply is:</p> <ul style="list-style-type: none"> • 3PR=OK (The PMM 7010 has been set for radiated mode) • 3PR =BERR (The command has been ignored for the following: <ul style="list-style-type: none"> • The instrument is not idling and therefore cannot switch to a different mode. In such an event, stop the current process (Manual, Analyzer or Sweep) and put it back to Idle. • 3PR =SERR (The command contains a syntax error)

7.5.3 Analyzer Reply

The PMM 7010 replies to the command “**SAGO**” sending back an array of bytes which contains all the information needed to draw a sweep. Typically, the user should first send the PMM 7010 all the setting commands to insure the receiver is correctly set on the wanted parameters and then read the reply. Just as an example, the user could send the following commands:

7.5.3.1 Reply example

#SAAT -1*	Set Attenuator Automatic mode
#SAPA Off*	Switch Preampfier OFF
#SPLM a*	Switch Pulse Limiter OFF
#SAFF 150e3,30e6*	Sets the Start frequency to 150kHz and Stop frequency to 30MHz
#SAHT 2*	Sets the hold time to 2 ms
#SADT 2*	Sets the detector to AVG
.....	More Command
.....	More Command
#SAGO *	Start Sweep in Analyzer Mode

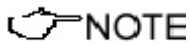

The PMM7010 replies by sending a 48 bytes header followed by a variable size array of integer (the size depends on frequency settings) as follows:

HEADER			
ID Byte	Value	Meaning	
1	A	The first 8 Bytes are just a fixed header and acknowledge the command	
2	G		
3	O		
4	=		
5	O		
6	K		
7	0x13 (CR)		
8	0x10 (LF)		
9	Start Frequency	Little Endian 32 bit Float figure representing the start frequency of sweep	
10			
11			
12			
13	Stop Frequency	Little Endian 32 bit Float figure representing the Stop frequency of sweep	
14			
15			
16			
17	Step Frequency	Little Endian 32 bit Float figure representing the step frequency of sweep	
18			
19			
20			
21	Reserved	...	
...	...		
26	...		
27	Attenuator		Little Endian 16 bit integer representing the attenuator used
28			
29	Reserved	...	
...		
48		

***** End of Header ***** (continued) From here all figures represent the level referred to the tuned frequency And are expressed in hundredth of dBm		
49	Level Fstart	Little Endian 16 bit integer representing the level referred to start frequency.
50		
51	Level Fstart +Fstep	Little Endian 16 bit integer representing the level referred to start frequency plus step frequency
52		
51	Level Fstart +2*Fstep	Little Endian 16 bit integer representing the level referred to start frequency plus 2 * step frequency
52		
....
....
nn	Level Fstop	Little Endian 16 bit integer representing the level referred to Stop frequency
nn+1		

 **NOTE** The number of levels replied is calculated by the formula $1+(Fstop-Fstart)/Fstep$. However, because of the different approximation in managing floating point figures, please note that the number of received levels may slightly differ specially with big difference in (Fstop-Fstart).

It is always possible to terminate a sweep before its natural end by sending the command SSTOP.

7.5.4 Sweep Structure

The PMM 7010, in order to optimize memory, stores measures (sweeps) in dynamic mode. This means that a single sweep does not have a fixed size but it varies depending on the sweep itself. Moreover, in order to have a sweep made of different steps (as for example band A and band B), often sweeps are split into two single sweeps. Basically, the higher the span, the wider the size of sweeps. Here below there is a comprehensive description of the structure in which a sweep is stored by the PMM 7010.

The full structure is obtained by the reply to the command “**?FSF n**”.

The PMM7010 replies by first sending a **Little Endian 32 bit long representing the size of the array**, then a 512 bytes main header plus an additional 512 bytes sweeps header followed by a variable size array of integer (the size depends on frequency settings) as follows:

ID Byte	Mnemonic	Meaning
1	Size of data	Little Endian 32 bit long representing the size in byte of full sweep
2		
3		
4		

Main Header		
ID Byte	Mnemonic	Meaning
1	Start Frequency	Little Endian 32 bit Float figure representing the start frequency of full sweep
2		
3		
4		
5	Stop Frequency	Little Endian 32 bit Float figure representing the Stop frequency of full sweep
6		
7		
8		
9	NumSweep	Little Endian 16 bit integer representing the number of single sub-sweeps forming the full sweep
10		
11	Detector	Little Endian 16 bit integer representing the detector used
12		
13	Reserved	
...
498		
499	Conversion Factor	Null terminated string containing the name of the conversion factor used
...		
512		
***** End of Main Header *****		

Sweeps header		
Sweep #n		
ID Byte	Mnemonic	Meaning
513+(n-1)*32	Start Frequency Sub1	Little Endian 32 bit Float figure representing the start frequency of sub-sweep #1
514+(n-1)*32		
515+(n-1)*32		
516+(n-1)*32		
517+(n-1)*32	Stop Frequency Sub1	Little Endian 32 bit Float figure representing the Stop frequency of sub-sweep #1
518+(n-1)*32		
519+(n-1)*32		
520+(n-1)*32		
521+(n-1)*32	Step Frequency Sub1	Little Endian 32 bit Float figure representing the Step frequency of sub-sweep #1
522+(n-1)*32		
523+(n-1)*32		
524+(n-1)*32		
525+(n-1)*32	OffRec1	Little Endian 32 bit long representing the address of the array level of sub-sweep #1 This figure must be multiplied by 2
526+(n-1)*32		
527+(n-1)*32		
528+(n-1)*32		
529+(n-1)*32	LenRec1	Little Endian 32 bit long representing the size (in 16 bit words) of current sub-sweep #1 This figure must be multiplied by 2
530+(n-1)*32		
531+(n-1)*32		
532+(n-1)*32		
533+(n-1)*32	Detector Sub1	Little Endian 16 bit integer representing the detector used #1 The meaning of each individual bit is : <ul style="list-style-type: none"> o 0x0001 --> Peak o 0x0002 --> Avg o 0x0004 --> RMS o 0x0008 --> QPeak o 0x0010 --> C-Rms o 0x0020 --> C-Avg o 0x0200 --> Smart Avg o 0x0400 --> Smart RMS o 0x0800 --> Smart QPeak o 0x1000 --> Smart C-Rms o 0x2000 --> Smart C-Avg
534+(n-1)*32		
535+(n-1)*32	Reserved	
...
544+(n-1)*32		

 **NOTE**

Then, the arrays containing the level related to the tuned frequencies can be interpreted using the data OffRec and LenRec (respectively OffRec1, LenRec1 for sweep 1 and OffRec2, LenRec2 for sweep 2) as follows:

Level Array		
From here all figures represent the level referred to the tuned frequency And are expressed in hundredth of dBm		
OffRecn+1	Level Fstart Peak	Little Endian 16 bit integer representing the level referred to start frequency of sub sweep n.
OffRecn +2		
OffRecn +3	Level Fstart Alternate Detector	Little Endian 16 bit integer representing the level of the alternate detector referred to start frequency of sub sweep n.
OffRecn +4		
OffRecn +5	Level Fstart +Fstep	Little Endian 16 bit integer representing the level referred to start frequency of sub sweep n plus step frequency of sub sweep n.
OffRecn +6		
OffRecn +7	Level Fstart +Fstep Alternate Detector	Little Endian 16 bit integer representing the level of the alternate detector referred to start frequency of sub sweep n plus step frequency of sub sweep n.
OffRecn +8		
OffRecn +9	Level Fstart +2*Fstep	Little Endian 16 bit integer representing the level referred to start frequency of sub sweep n plus 2* step frequency of sub sweep n.
OffRecn +10		
OffRecn +11	Level Fstart +2*Fstep Alternate Detector	Little Endian 16 bit integer representing the level of the alternate detector referred to start frequency of sub sweep n plus 2* step frequency of sub sweep n.
OffRecn +12		
....
....
OffRecn + (2*LenRecn) +1	Level Fstop	Little Endian 16 bit integer representing the level referred to Stop frequency of sub sweep n.
OffRecn + (2*LenRecn) +2		
OffRecn + (2*LenRecn) +3	Level Fstop Alternate Detector	Little Endian 16 bit integer representing the level of the alternate detector referred to Stop frequency of sub sweep n.
OffRecn + (2*LenRecn) +4		

- 7.5.5 Procedure to read a measure stored by PMM 7010**
1. Send the command **#?FSF n *** .
 2. Wait for the size of array
 3. Wait for the first 1024 bytes in order to get both main and sweeps header
 4. Read the relevant data concerning Start, Stop of full sweep as well as single sub-sweeps if they are more than one.
 5. Go to the offset OffRec1 (OffRec1 *2) in the received buffer and read all the LenRec1 levels.
 6. If the number of Sub-Sweeps is 2, go to the offset OffRec2 in the received buffer and read all the LenRec2 levels.
 7. Next Address is (OffRec2+ LenRec1)*2

This page has been left blank intentionally

Caro cliente

grazie per aver acquistato un prodotto NARDA! Sei in possesso di uno strumento che per molti anni ti garantirà un'alta qualità di servizio. NARDA riconosce l'importanza del Cliente come ragione di esistenza; ciascun commento e suggerimento, sottoposto all'attenzione della nostra organizzazione, è tenuto in grande considerazione. La nostra qualità è alla ricerca del miglioramento continuo. Se uno dei Suoi strumenti NARDA necessita di riparazione o calibrazione, può aiutarci a servirla più efficacemente compilando questa scheda e accludendola all'apparecchio.

Tuttavia, anche questo prodotto diventerà obsoleto. In questo caso, ti ricordiamo che lo smaltimento dell'apparecchiatura deve essere fatto in conformità con i regolamenti locali. Questo prodotto è conforme alle direttive WEEE dell'Unione Europea (2002/96/EC) ed appartiene alla categoria 9 (strumenti di controllo). Lo smaltimento, in un ambiente adeguato, può avvenire anche attraverso la restituzione del prodotto alla NARDA senza sostenere alcuna spesa. Può ottenere ulteriori informazioni contattando i venditori NARDA o visitando il nostro sito Web www.narda-sts.it.

Dear Customer

thank you for purchasing a NARDA product! You now own a high-quality instrument that will give you many years of reliable service. NARDA recognizes the importance of the Customer as reason of existence; in this view, any comment and suggestion you would like to submit to the attention of our service organization is kept in great consideration. Moreover, we are continuously improving our quality, but we know this is a never ending process. We would be glad if our present efforts are pleasing you. Should one of your pieces of NARDA equipment need servicing you can help us serve you more effectively filling out this card and enclosing it with the product.

Nevertheless, even this product will eventually become obsolete. When that time comes, please remember that electronic equipment must be disposed of in accordance with local regulations. This product conforms to the WEEE Directive of the European Union (2002/96/EC) and belongs to Category 9 (Monitoring and Control Instruments). You can return the instrument to us free of charge for proper environment friendly disposal. You can obtain further information from your local NARDA Sales Partner or by visiting our website at www.narda-sts.it.

Servizio richiesto: *Service needed:*

Solo taratura Riparazione Riparazione & Taratura Taratura SIT Altro:
 Calibration only Repair Repair & Calibration Certified Calibration Other:

Ditta:

Company:

Indirizzo:

Address:

Persona da contattare:

Technical contact person:

Telefono:

Phone n.

Modello:

Equipment model:

Numero di serie:

Serial n.

Accessori ritornati con l'apparecchiatura: **Nessuno** **Cavo(i)** **Cavo di alimentazione** **Altro:**
 Accessories returned with unit: *None* *Cable(s)* *Power cable* **Other:**

Sintomi o problemi osservati: *Observed symptoms / problems:*

Guasto: **Fisso** **Intermittente** **Sensibile a:** **Freddo** **Caldo** **Vibrazioni** **Altro**
 Failure: *Continuous* *Intermittent* **Sensitive to:** *Cold* *Heat* *Vibration* *Other*

Descrizione del guasto/condizioni di funzionamento:

Failure symptoms/special control settings description:

Se l'unità è parte di un sistema descriverne la configurazione:

If unit is part of system please list other interconnected equipment and system set up:

