

SEALEVEL®

DIO-16.LCPI USER MANUAL



ITEM# 8012

Contents

BEFORE YOU GET STARTED	4
WHAT'S INCLUDED	4
ADVISORY CONVENTIONS	4
OPTIONAL ITEMS	5
INTRODUCTION	7
FEATURES.....	7
OTHER SEALEVEL PCI DIGITAL I/O PRODUCTS	8
SOFTWARE INSTALLATION	9
WHERE TO GET SEALEVEL SOFTWARE	9
WINDOWS INSTALLATION.....	9
GUIDED SOFTWARE INSTALLATION	10
MANUAL SOFTWARE INSTALLATION.....	12
LINUX INSTALLATION	13
PHYSICAL INSTALLATION	15
PROGRAMMING FOR WINDOWS	17
SAMPLES AND UTILITIES.....	17
PROGRAMMING FOR LINUX.....	17
DIRECT HARDWARE CONTROL.....	17
REGISTER LAYOUT	18
READING THE INPUTS	18
READING THE OUTPUTS.....	18
WRITING THE OUTPUTS	18
INTERRUPT CONTROL.....	18
INTERRUPT MODE SELECT TABLE	19
INTERRUPT READ.....	19
INPUT PORTS	20
INPUT PORT PIN ASSIGNMENTS (DB-44 FEMALE).....	20
OUTPUT PORTS (REED RELAY).....	21
OUTPUT PORTS (REED RELAY) PIN ASSIGNMENTS (DB-44 FEMALE).....	21
POWER AND GROUND PIN ASSIGNMENTS (DB-44 FEMALE).....	22
DB-37 MALE PIN ASSIGNMENT	23
TECHNICAL SPECIFICATIONS	25
INPUT PORTS	25
OUTPUT RELAYS.....	25
PCB DIMENSIONS.....	25
ENVIRONMENTAL SPECIFICATIONS.....	26
POWER REQUIREMENTS.....	26
MANUFACTURING.....	26
APPENDIX A - TROUBLESHOOTING	27
SOFTWARE.....	27
HARDWARE	28
BIOS.....	29
DEVICE MANAGER VERIFICATION	29
TROUBLESHOOTING/VERIFICATION UTILITIES FOR SEAIO CLASSIC PRODUCTS	30
SEAIO DEVICE DRIVER CONFIGURATION	34

CARD SELECTION CONFIGURATION	34
APPENDIX B - HANDLING INSTRUCTIONS.....	37
ESD WARNINGS	37
APPENDIX C - EXAMPLE CIRCUITS.....	38
INPUT CIRCUIT	38
OUTPUT CIRCUIT.....	38
APPENDIX D - 8012 PCB DRAWING	39
APPENDIX E - HOW TO GET ASSISTANCE.....	40
TECHNICAL SUPPORT	40
WARRANTY	41
WARRANTY POLICY.....	41
NON-WARRANTY REPAIR/RETEST	41
HOW TO OBTAIN AN RMA (RETURN MERCHANDISE AUTHORIZATION).....	41

Before You Get Started

WHAT'S INCLUDED

The DIO-16.LPCI is shipped with the following items. If any of these items is missing or damaged, please contact Sealevel for replacement.

- DIO-16.LPCI Adapter
- Item# 8012 ships with Low Profile PCI bracket
- Item# 8012S ships with a Standard PCI bracket
- Sealevel Seal/O Software CD

ADVISORY CONVENTIONS



Warning - The highest level of importance used to stress a condition where damage could result to the product or the user could suffer serious injury.



Important - The middle level of importance used to highlight information that might not seem obvious or a situation that could cause the product to fail.



Note - The lowest level of importance used to provide background information, additional tips, or other non-critical facts that will not affect the use of the product.



High Voltage Warning - USE EXTREME CAUTION!



High voltages will be present on the Seal/O family of products when high voltage is connected. Never handle the printed circuit board when high voltage signals are connected to the board.

OPTIONAL ITEMS

Depending upon your application, you are likely to find one or more of the following items useful for interfacing the DIO-16.LPCI to real-world signals.

All items can be purchased from our website (<http://www.sealevel.com>) or by calling +1 864-843-4343.

Cables

DB44 Male to DB44 Female, 72" Extension Cable (Item# CA185)	
<p>The CA185 is a standard DB44M to DB44F extension cable. Extend a DB44 cable or locate a piece of hardware where it is needed with this six foot (72") cable. The connectors are pinned one-to-one so the cable is compatible with any device or cable with DB44 connectors. The cable is fully shielded against interference and the connectors are molded to provide strain relief. Dual metal thumbscrews secure the cable connections and prevent accidental disconnection.</p>	
DB44 Male to BD37 Male, 72" Cable (Item# CA206)	
<p>DB44 Male to DB37 Male Cable, 72 in Length - for 8012. The CA206 is useful for interfacing the DB44 connector on the 8012 to the DB37 connector on the TB02 terminal block.</p>	

Terminal Blocks

Terminal Block – DB37 Male and DB37 Female to 27 Screw Terminals (Item# TB02)

The TB02 terminal block can be used to break out serial and digital DB37 connectors to screw terminals for easy field wiring. The terminal block was designed with both DB37 male and female connectors, therefore; it can be used with any DB37 board regardless of the board's port gender.



Terminal Block Kit – DB37 Male and DB37 Female to 27 Screw Terminals (Item# TB02-KT)

The TB02-KT terminal block can be used to break out serial and digital DB37 connectors to screw terminals for easy field wiring. The terminal block was designed with both DB37 male and female connectors, therefore; it can be used with any DB37 board regardless of the board's port gender. The TB02-KT ships with a RoHS compliant TB02 terminal block, a 6 piece of slotted Snap Track, and two DIN-rail mounting clips.



Cable & Terminal Block Kit

Terminal Block Kit – TB02 + CA206 Cable (Item# KT111)

Terminal Block KT111 simplifies field wiring requirements by creating a direct connection between a TB02 terminal block and the 8012 board. The KT111 includes the TB02 terminal block, CA206 cable, ST101 Snap Track and STDIN mounting clips.



Reference Book

The Digital I/O Handbook – A Practical Guide to Industrial Input and Output Applications (Item# REF101)

Renowned technical author Jon Titus and president and CEO of Sealevel Systems, Tom O'Hanlan, clearly explain real-world digital input/output implementation from both a hardware and software perspective. Whether you are a practicing engineer or a student, *The Digital I/O Handbook* will provide helpful insight you will use again and again.



Introduction

The DIO-16.LPCI provides 8 optically isolated inputs and 8 reed relay SPST (single pole-single throw) outputs. The inputs protect the PC and other sensitive equipment from spikes and ground loop current that can be generated in industrial environments, while the outputs provide high quality, long life, low current (10 Watt maximum), dry contact switch closures. Reed relays are well suited for low current applications. The relays are normally open, and will close when energized.

The board meets the requirements for the MD1 "Low Profile" specification as defined by the PCISIG in the PCI 2.2 Specifications Low Profile Addendum. The DIO-16.LPCI also features Universal Bus (3.3 and 5.0V) operation.

The DIO-16.LPCI is designed to be used with a variety of Operating Systems including Windows, Linux and DOS. The Seal/O API (Application Programming Interface) included on the CD shipped with the DIO-16.LPCI provides a variety of useful high-level function calls implemented as a Windows dynamic link library (.DLL) and as a Linux static library (.a). In addition to the API, Seal/O includes a device driver, sample code, and utilities to simplify software development.

FEATURES

- Eight optically isolated inputs optimized for +5V
- Eight Reed relay outputs (SPST)
- Highly reliable 10VA Reed relays
- MD1 Low Profile and Universal Bus (3.3V and 5V) compatible
- Power (+5V and +12V) and ground provided on connector
- Seal/O Classic software supports Windows and Linux Operating Systems

OTHER SEALEVEL PCI DIGITAL I/O PRODUCTS

Product	Item#	Description
PIO-32.PCI	8010	32 TTL Inputs/Outputs
PIO-48.PCI	8005	48 TTL Inputs/Outputs
PIO-96.PCI	8009	96 TTL Inputs/Outputs
REL-16.PCI	8003	16 Reed Relay Outputs
DIO-32.PCI	8004	16 Reed Relay Outputs/16 Opto-isolated Inputs
DIO-32.PCI	8004H	16 Reed Relay Outputs/16 Opto-isolated Inputs (10-30V)
ISO-16.PCI	8006	16 Opto-isolated Inputs
ISO-16.PCI	8006H	16 Opto-isolated Inputs (10-30V)
REL-32.PCI	8007	32 Reed Relay Outputs
PLC-16.PCI	8011	8 Form C Relay Outputs/8 Opto-isolated Inputs
DIO-32.PCIE	8004e	16 Reed Relay Outputs/16 Opto-isolated Inputs
DIO-32.PCIE	8004He	16 Reed Relay Outputs/16 Opto-isolated Inputs (10-30V)

Software Installation



This section contains helpful information pertaining to the installation of supported Sealevel Systems, Inc. software packages. First, the process of acquiring the software is discussed. Next, the installation is detailed in a step-by-step guide for Windows and Linux operating systems.

WHERE TO GET SEALEVEL SOFTWARE

All Sealevel products are shipped with media containing the installers for each software package available. If the media is otherwise unavailable or if desired, the current versions of Sealevel software packages can be obtained from the Sealevel website (see following instructions). If you already have the Sealevel software, proceed to the Windows or Linux installation section.

1. Sealevel software for Windows and Linux operating systems is available at these links:
 - [Software for Windows](#)
 - [Software for Linux](#)
2. Choose the link for the desired software package and click on the 'Download File' link to download the current driver.
3. Proceed to the Manual Software Installation guide for your operating system.

WINDOWS INSTALLATION

-  Do not connect the hardware until the software has been successfully installed.
-  To install Sealevel software, you must log in as an administrator or have administrator privileges in Windows.

GUIDED SOFTWARE INSTALLATION

- Insert the Sealevel media into your PC.
- If the 'AutoRun' feature is enabled for this media the software will automatically launch.
- Otherwise, navigate to the root directory of the media and double-click the 'autorun.exe' application to launch the installation window.
- Select 'Install' as demonstrated in the image below.



- Type the part number for your adapter in the text box and press the 'Enter' key, or click on the drop box to scroll from the listing to select your product.

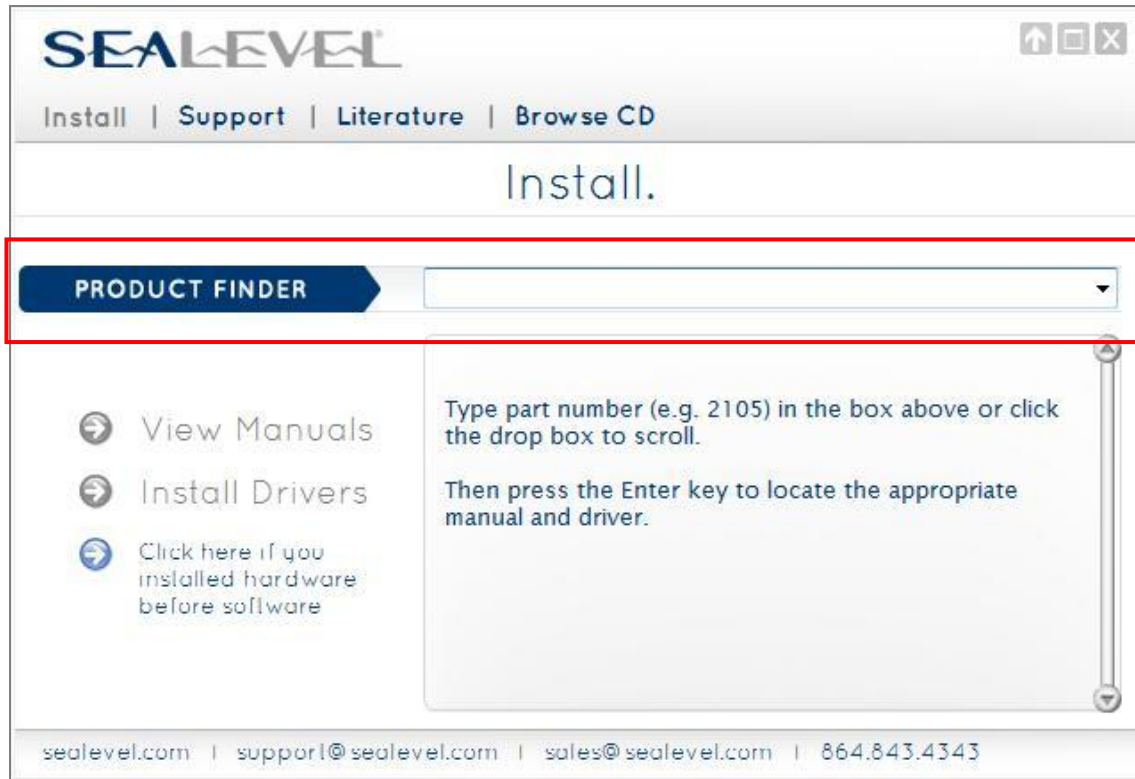

If you installed your hardware prior to loading/installing the software, please click on the ['Click here if you installed hardware before software'](#) link and follow the listed instructions.

1. Click the 'Install Drivers' button to launch the Installation Wizard.
2. When the 'InstallShield Wizard' window appears, click the 'Next' button to initiate the software installation.
3. When the 'License Agreement' window appears, accept the terms and click 'Next' to continue. You can click the 'Print' button to print out a copy of the agreement for your records. If you do not accept the terms of the agreement, the installation will stop.
4. When the 'Ready to Install the Program' window appears, click the 'Install' button to install the software onto the hard drive of your computer. The files will be automatically installed into the 'C:\Program Files' folder on your computer. Some versions of Windows will halt the installation and provide you with a dialog box which will ask you for permission for the installer to make changes to your



computer. Click on the “Allow” button to continue installation of your Sealevel software.

5. The setup file will automatically detect the operating environment and install the proper components. Next follow the information presented on the screens that follow. Once the installation is complete, close the disk installation window.
6. Refer to the Physical Installation section to connect and install your hardware.

MANUAL SOFTWARE INSTALLATION

1. To install a software package from the Sealevel media, browse the Sealevel Systems media 'Software' directory. For example:
Software\SealO\Windows\SealO Installer.exe
2. If you are using Windows Vista or newer operating systems, *right* click on the installer executable and choose 'Run as Administrator'. If you are using an operating system prior to Windows Vista, double click on the executable to launch the InstallShield and initiate the driver installation.
3. Please refer to step six above in the Guided Software Installation section and follow the remaining installation steps.

LINUX INSTALLATION

-  Most Sealevel Linux software is distributed as source code. To use the software, it must be compiled. Refer to the README file in each package for system prerequisites.
-  You must have administrative privileges to install the software. It is not necessary to have administrative privileges to build or use the software.
-  All command syntax is case sensitive.

1. Insert the Sealevel media into your PC.
2. If your desktop environment does not auto-mount the media, you will need to do so manually using the `mount` command. You may need administrative privileges for the `mount` command to succeed.
3. Next change to the Sealevel media directory. For example, if the mount point of your optical drive is `/cdrom`:

```
$ cd /cdrom/Software/SeaIO/Linux
```

4. Copy `[package name].tar.gz` to your home directory by typing:

```
$ cp SeaIO_X.Y.Z.tar.gz ~
```

5. Change to your home directory by typing:

```
$ cd
```

6. Extract the software from the compressed archive by using:

```
$ tar -zxvf SeaIO_X.Y.Z.tar.gz
```

7. Change to the package directory by typing:

```
$ cd seaio
```

8. Compile the software from source by typing:

```
$ make
```

9. Elevate permission level by changing to root:

```
$ su
```

Or use the 'super user do' command:

```
$ sudo -s
```

10. Install the drivers by typing:



```
$ make install
```

11. If the package contains drivers, refer to the documentation for your package to find the command that will load your drivers. For example, the Seal/O package uses:

```
$ seaioload
```

At this point, the driver has enabled the hardware and it is ready to use. You now have the option to run a test utility on it. Test utilities were compiled in Step 8, and they are located in the package's folder named `seai0/utilities/` and installed globally in Step 10 to: `/usr/bin`.

Physical Installation

-  The Sealevel adapter can be installed in an ISA/PCI/PCIe expansion slot.
-  5V keyed PCI cards will not fit or work in 3.3V keyed PCI slots.

ISA Card Edge (5V)

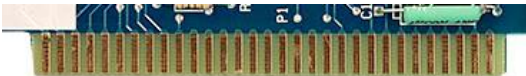

PCI Bus Card Edge (5V)





Universal PCI Bus Card Edge (3.3 and 5V)



PCI Express x1



-  Do not install the adapter in the machine until the product software has been fully installed.
-  To prevent damage from improper handling, please reference Appendix A - ESD Handling Instructions.

1. Turn off PC power. Disconnect the power cord.
2. Remove the PC case cover.
3. Locate an available ISA/PCI/PCIe slot and remove the blank metal slot cover.
4. Gently insert the ISA/PCI/PCIe adapter into the slot. Make sure that the adapter is seated properly.
5. Replace the screw you removed for the blank and use it to secure the adapter bracket into the slot. This is required to ensure FCC Part 15 compliance.
6. Replace the cover.
7. Connect the power cord.

Programming the DIO-16.LPCI

Sealevel's Seal/O software is provided to assist in the development of reliable applications for the Sealevel Systems family of digital I/O adapters. Included on the Seal/O CD are driver functions for use in accessing the I/O as well as helpful samples and utilities.

PROGRAMMING FOR WINDOWS

The Seal/O API (Application Programmer Interface) provides a variety of useful high-level function calls implemented in a Windows dynamic link library (DLL). The API is defined in the help file (Start/Programs/SealO/SealO Help) under "Application Programmers Interface". This help file also includes detailed information dealing with installation / removal of the software and information about latency, logic states, and device configuration.

For C language programmers we recommend using the API to access the DIO-16.LPCI. If you are programming in Visual Basic, using the ActiveX control included with Seal/O is advised.

SAMPLES AND UTILITIES

A variety of sample programs and utilities (both executable and source code) are included with Seal/O. Further documentation on these samples can be found by selecting "Start/Programs/SealO/Sample Application Description". Information about where the files are physically stored on your disk is also included in this same file.

PROGRAMMING FOR LINUX

Seal/O for Linux consists of two major parts: a kernel module and a library. The kernel module is a simple IO pass-through device, allowing the library to handle the more sophisticated functions provided to Seal/O users. It is provided in a 'tarball' format and can easily be compiled and included in the kernel build.

DIRECT HARDWARE CONTROL

In systems where the user's program has direct access to the hardware (DOS) the tables that follow give the mapping and functions that the DIO-16.LPCI provides. The DIO-16.LPCI provides two parallel input/output (I/O) ports. The ports are organized as ports A and C. Port A is an input port interfaced to optically-isolated inputs, while port C is the reed relay output port.

REGISTER LAYOUT

Reference the following sections for more information about the meaning and use of the registers available.

Address	Mode	Mode	D7	D6	D5	D4	D3	D2	D1	D0
Base+0	Input Port A	RD	PAD7	PAD6	PAD5	PAD4	PAD3	PAD2	PAD1	PAD0
Base+2	Output Port C	RD/WR	PCD7	PCD6	PCD5	PCD4	PCD3	PCD2	PCD1	PCD0
Base+5	Interrupt Status	RD/WR	IRQEN	IRQST	0	0	0	0	IRC1	IRC0

READING THE INPUTS

The inputs are active Low. If no voltage is applied across one of the differential inputs it returns a one on that bit. If an AC or DC voltage is applied it returns a zero on that bit.

READING THE OUTPUTS

The relay ports return the ones complement of the value that is currently being used to drive the relays. When using the API the actual value is returned not the complement of the value.

WRITING THE OUTPUTS

The output ports are the only ports that can be written. The relays on a standard DIO-16.LCPI are normally open. To close a relay a one must be written to the appropriate bit.

INTERRUPT CONTROL

When enabled, interrupts are generated on Port A bit D0.

IRQEN	Interrupt enable	1 = enabled	0 = disabled (0 on power up)
IRC0	Interrupt mode select, see table below		
IRC1	Interrupt mode select, see table below		

INTERRUPT MODE SELECT TABLE

Interrupt source is Base+5 bits D1 and D0. When selecting the Interrupt Type, always disable interrupts prior to changing or setting states. This will help prevent inadvertent or unexpected interrupts from occurring.

IRC1	IRC0	Interrupt Type
0	0	Low Level
0	1	High Level
1	0	Falling Edge
1	1	Rising Edge



When using the High and Low Level interrupts, an interrupt occurs when input D0 changes to either a High or Low state. This will cause the computer to remain in an interrupt state until the input state changes.

INTERRUPT READ

Reading the Interrupt Status port (Base+5) clears any interrupt pending.

IRQST	(D0) Interrupt Status	1 = interrupt pending, 0 = none
-------	-----------------------	---------------------------------

INPUT PORTS

Port A is an 8 bit input port connected to optically isolated input sensors. Each sensor can be used to interface a voltage input and then sense whether the voltage is on or off. Each sensor is isolated (with respect to a common ground) from every other sensor, and is also isolated with respect to the host PC ground. This means that signals such as low-level AC line voltage, motor servo voltage, and control relay signals can be 'sensed', or read by the PC, without the risk of damage due to ground loops or ground faults.

Each sensor input pair has a current limiting resistor that is used to limit the input current to the opto-isolator. The opto-isolator has two 'back-to-back' diodes internally. This allows AC or DC signals to be sensed, regardless of polarity. When the applied voltage is high enough to cause the LED in the opto-isolator to turn-on, the output of the opto-isolator goes low (0 volts) and the signal is read as a low logic level (binary 0) by the PC. When the input signal is too low to turn on the opto-isolator, the output goes high and the port bit is read by the PC as a high logic level (binary 1).

The input impedance of each isolated input is approximately 560 ohms (factory default). The opto-isolator requires approximately 3mA to turn on. The maximum input current is 20mA.



The input circuits are not intended for monitoring 120-volt AC circuits. In addition to being too high a voltage for the circuits, it is dangerous to have that high a voltage on the card.

INPUT PORT PIN ASSIGNMENTS (DB-44 FEMALE)

Port A Bit	Port A Pins
0	2,40
1	3,41
2	4,36
3	5,37
4	6,38
5	7,42
6	8,43
7	9,44

DB-44 Input Application Example Wired on Connector

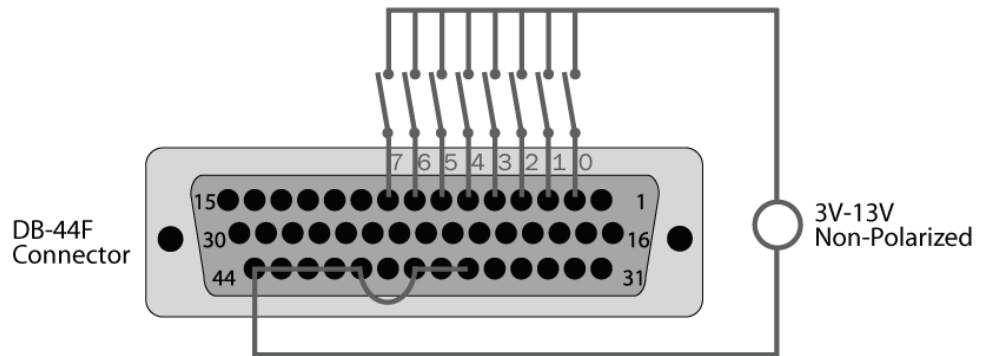

The above diagram is representative of how dry contact inputs (or current / voltage sources) can be monitored by the optically isolated inputs. When switch 1 above is closed, it will allow current to flow from the power source, into pin 3 of the DB-44, through the optocoupler, out pin 41, and back to the power source. If the current flow is between 3 and 20 milliamps, this input will be read as logic “0”. All the input associated with all open switches will be read as logic “1”.

In the diagram above, pins 36-38, and 40-44 are joined, providing a common return path for the optocouplers. In this case, the interconnections are being made on the connector itself. In the DB-37 diagram below the return path is supplied external to the connector. Also for complete electrical isolation, each input / output pair can be powered from an individual power source with no common present.

OUTPUT PORTS (REED RELAY)

Reed relays provide very high quality, long life, low current (10 Watt maximum), dry contact switch closures. Reed relays are not suited for high current applications, and can be destroyed by inductive load switching, where a spark occurs across the contacts internally. The relays are normally open, and close when energized.

OUTPUT PORTS (REED RELAY) PIN ASSIGNMENTS (DB-44 FEMALE)

Port C Bit	Relay	Port C Pins
0	K3	10,28
1	K2	11,29
2	K1	12,30
3	K5	13,31
4	K4	14,32
5	K6	15,33
6	K7	16,34
7	K8	17,35

DB-44 Output Application Example Wired on Connector

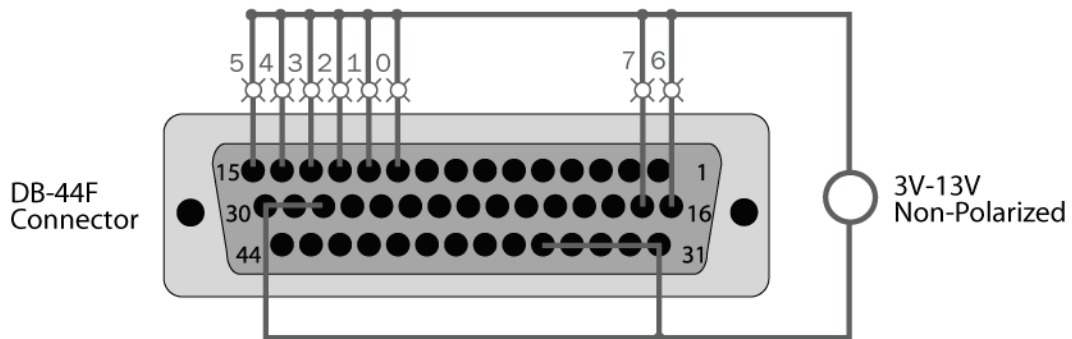

The above diagram is representative of how lights (or other devices) can be controlled by the relay outputs. When relay 2 on the card is closed, it will allow current to flow from the power source, into pin 12 of the DB-44, through the relay, out pin 30, and back to the power source thereby turning the light labeled “2” on.

In the diagram above, pins 28-30 and 31-35 of the connector are joined, providing a common return path for the circuit. In this case the interconnections are being made on the connector itself. In the DB-37 diagram below the return path is supplied external to the connector. For complete electrical isolation, each relay can be wired to an independent isolated circuit.

POWER AND GROUND PIN ASSIGNMENTS (DB-44 FEMALE)

Ground	22,23,24
+ 5 Volts	39
+ 12 Volts	1

DB-37 MALE PIN ASSIGNMENT

Via optional DB-44 Male to DB-37 Male 6' cable, Part Number CA206

Bit	Port A Pins	Port C Pins
0	2,20	10,28
1	3,21	11,29
2	4,22	12,30
3	5,23	13,31
4	6,24	14,32
5	7,25	15,33
6	8,26	16,34
7	9,27	17,35
GND	18,36,37	
+12V	1	
+5V	19	

DB-37 Input Application Example Wired from Connector

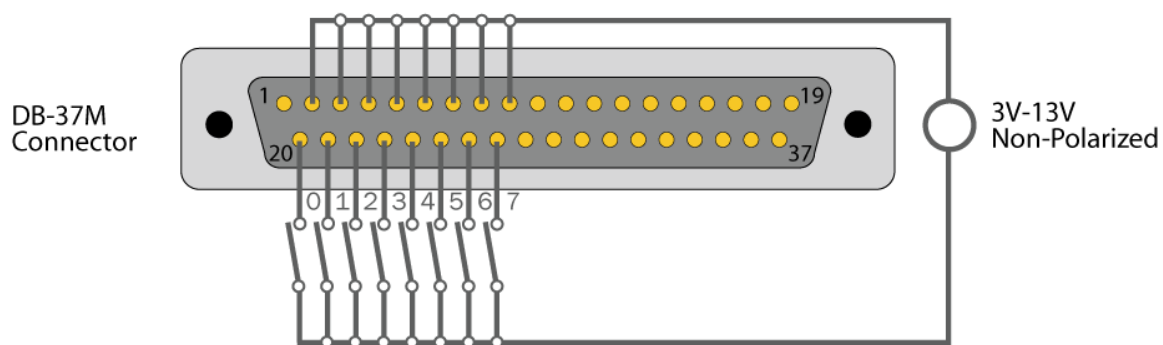

The diagram is representative of how dry contact inputs (or current / voltage sources) can be monitored by the optically isolated inputs. When switch 1 above is closed, it will allow current to flow from the power source, into pin 3 of the DB-37, through the optocoupler, out pin 21, and back to the power source. If the current flow is between 3 and 50 milliamps, this input will be read as logic "0". All the input associated with all open switches will be read as logic "1".

The above diagram shows that the common path to the optocouplers is provided external to the connector. The common path can be provided at the connector as shown in the DB-44 diagram above. Also for complete electrical isolation, each input / output pair can be powered from a individual power source with no common present.

DB-37 Output Application Example Wired from Connector

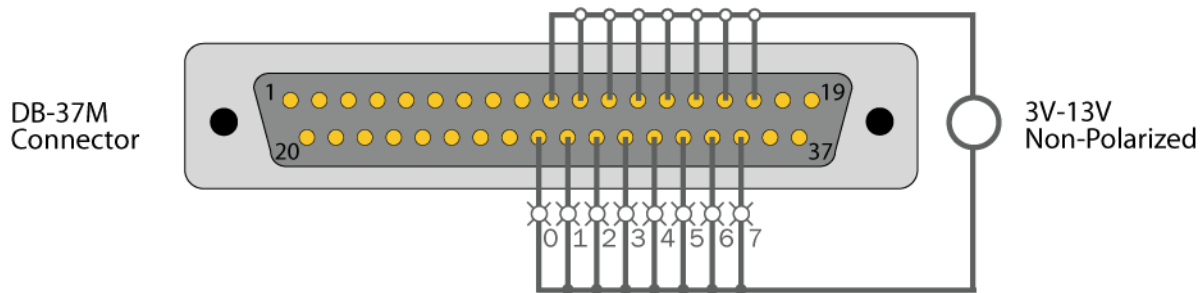

The diagram above diagram is representative of how lights (or other devices) can be controlled by the relay outputs. When relay 2 on the card is closed, it will allow current to flow from the power source, into pin 12 of the DB-37, through the optocoupler, out pin 30, and back to the power source thereby turning the light labeled "2" on.

The above diagram shows the common path to all the relays is provided external to the connector. The common path can be provided at the connector as shown in the DB-44 diagram above. For complete electrical isolation, each relay can be wired to an independent isolated circuit.

Technical Specifications

INPUT PORTS

Turn On Current	3mA
Isolator Diode Drop	1.1VDC
Resistor Power Max	.25W
Absolute Maximum Input Range	3-13VDC/VAC
Recommended Input Range	3-10VDC/VAC

OUTPUT RELAYS

Contact Max Power Rating	10W
Contact Voltage Max	10VDC/VAC
Contact Current Max	.5A AC/DC RMS
Contact Resistance, Initial	.10Ω
Rated Life: Low Load	200 Million Closures
Rated Life: Maximum Load	100 Million Closures
Contact Speed: Operate	.5mS
Contact Speed: Release	.2mS
Contact Speed: Bounce	.5mS
Max Operating Speed	600 Hz

PCB DIMENSIONS

Length	Width (Including Gold fingers)
4.7" (12.0 cm)	2.5" (6.4 cm)

ENVIRONMENTAL SPECIFICATIONS

Specification	Operating	Storage
Temperature Range	0°C - 70°C (32°F - 158°F)	40°C - 105°C (-58°F - 221°F)
Humidity Range	10 to 90% R.H. Non-Condensing	10 to 90% R.H. Non-Condensing

POWER REQUIREMENTS

+5VDC @ 280mA	+12VDC (optional)
---------------	-------------------

MANUFACTURING

All Sealevel Systems printed circuit boards are built to UL 94V0 rating and are 100% electrically tested. These printed circuit boards are solder mask over bare copper.

Appendix A - Troubleshooting

Following these simple troubleshooting steps can eliminate most common problems.



To install Sealevel Systems Software and hardware in Windows, you must log in as an administrator or have administrator privileges.

SOFTWARE

Installation

First, install the software driver and then install the I/O adapter. If the I/O adapter was installed first, complete the 'uninstall/reinstall' steps.

Next, verify that your Sealevel Software is properly installed. This places the required installation files in the correct locations. In Windows it will be located here: **Start – All Programs – SeaIO**

Uninstall/Reinstall

1. Install the most current Sealevel Software.



To obtain the most current software package from Sealevel's website, download from here:

- [Sealevel Software Drivers](#)
2. Navigate to the Device Manager (*right* click on 'My Computer' and choose 'Manage', then 'Device Manager').
 3. Look for the Seal/O Device category and expand it to expose the Sealevel adapter.
 4. *Right* click on the listed adapter and choose 'Uninstall'.
 5. Click on 'Actions' and choose 'Scan for hardware changes'.
 6. This will prompt the PC to scan and locate the Sealevel I/O adapter and properly initiate the installation and driver association.

HARDWARE

1. With the system powered down, verify the I/O adapter is seated properly into the slot.
2. Sealevel ISA and PCI Digital I/O adapters require 5V on the bus from the power supply.
3. Sealevel Universal PCI Digital I/O adapters are 3.3V signal compliant. The I/O adapter requires 5V on the bus for proper operation.

ISA Card Edge (5V)

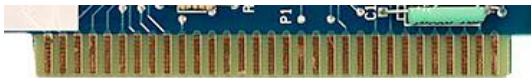

PCI Bus Card Edge (5V)



Universal PCI Bus Card Edge (3.3 and 5V)



PCI Express Card Edge



4. If a slot seems unresponsive, power the system down and install the I/O adapter on a different slot on the motherboard.
5. If your motherboard contains more than four PCI slots, it may have more than one PCI bridge to support the additional slots. Install our adapter in the first bank of PCI slots as these are supported by the PCI bridge closest to the CPU.
6. Install the Sealevel Software and I/O adapter in another computer.

BIOS

1. ISA bus devices require selecting available addressing and IRQ options in the computer systems BIOS. The IRQ selection must be set to 'Legacy Devices' in the BIOS setup menu.
2. For ISA bus adapters, the address selection on the digital I/O adapter must correspond to an address that is currently available in the operating system.
3. PCI and PCIe adapters are automatically assigned addressing and IRQs by the system BIOS based on availability. Ensure that available IRQs are set to PCI/PNP (this represents 'Plug and Play').
4. If hardware installation issues persist, remove other bus level devices from your system to verify if this corrects the problem.

DEVICE MANAGER VERIFICATION

Once your Sealevel Software is installed, verify the I/O adapter is properly enumerated. Navigate to the Device Manager for verification and configuration.

To access the Device Manager, right click on 'My Computer' and choose 'Manage'. When the Computer Management menu appears, choose 'Device Manager'.

TROUBLESHOOTING/VERIFICATION UTILITIES FOR SEAIO CLASSIC PRODUCTS

These three utilities were designed to verify the functionality of your Sealevel digital I/O adapters.

To access these utilities navigate to: Start - All Programs - SeaIO.

VB Test

This utility allows the setting and clearing of individual relays and groups of relays. It also offers timed activation of relays and monitoring of input signals.

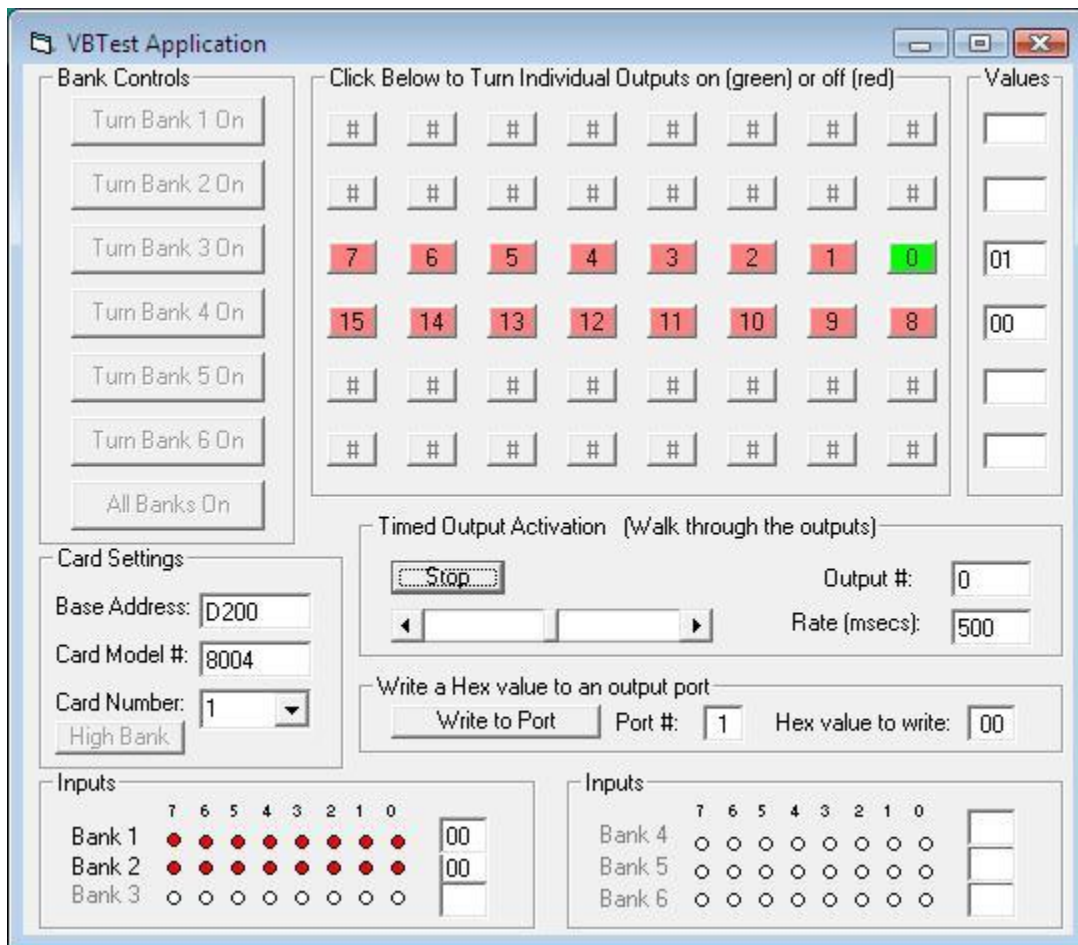

VCTEST

This utility allows the setting and clearing of individual relays. It also offers monitoring of input signals.

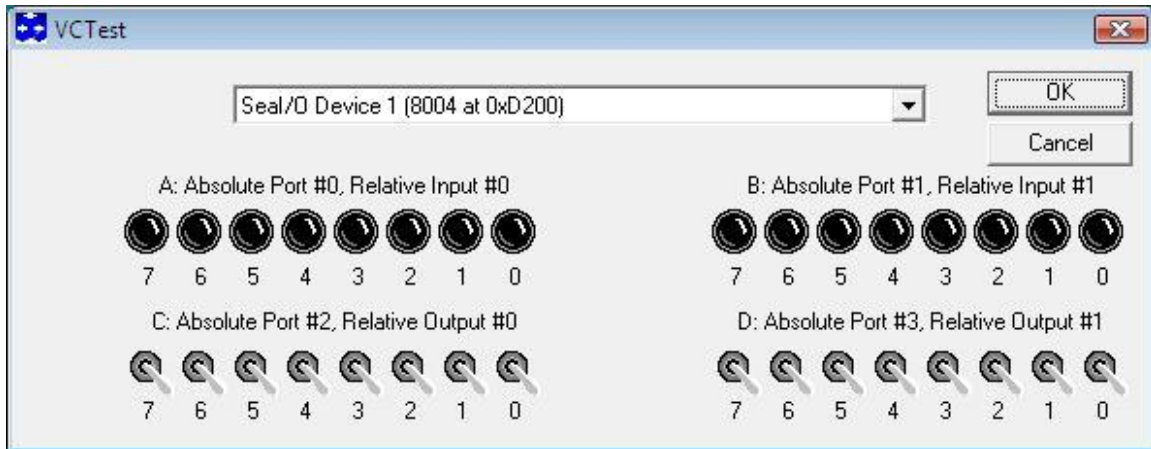

SealOTST

This utility is a Win32 console application designed for testing all calls to the driver. This utility is very useful for verifying proper SealO driver configuration and hardware adapter settings. A main menu offers choices for reading and writing ports, and setting and clearing relays. This utility also demonstrates the use of the NotifyInputChange API call.

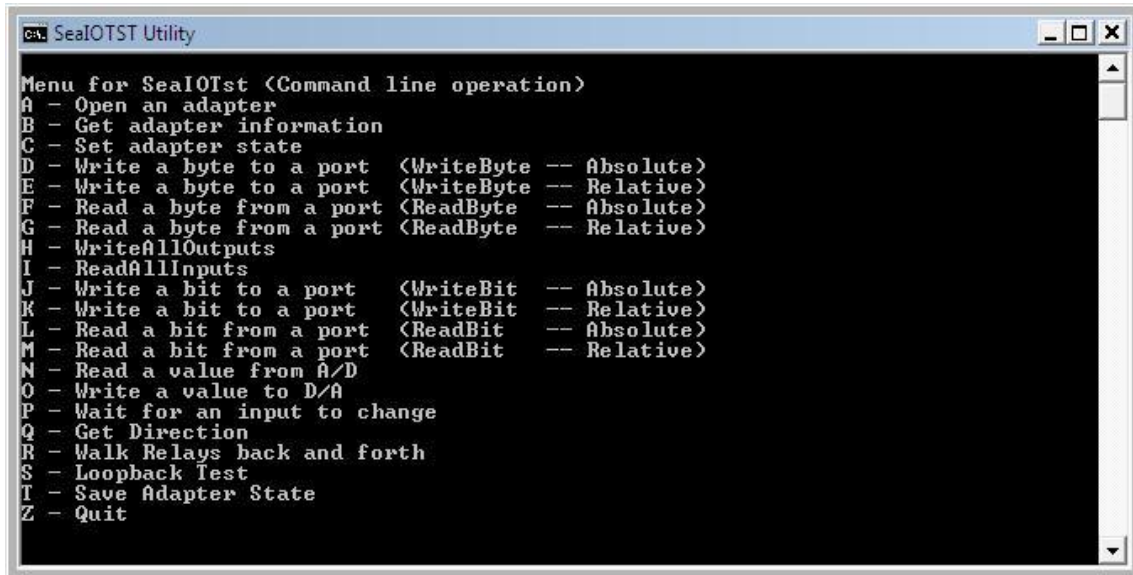

Seal/O Classic Hardware

This is an example of a properly enumerated Seal/O digital I/O adapter in Windows Device Manager.

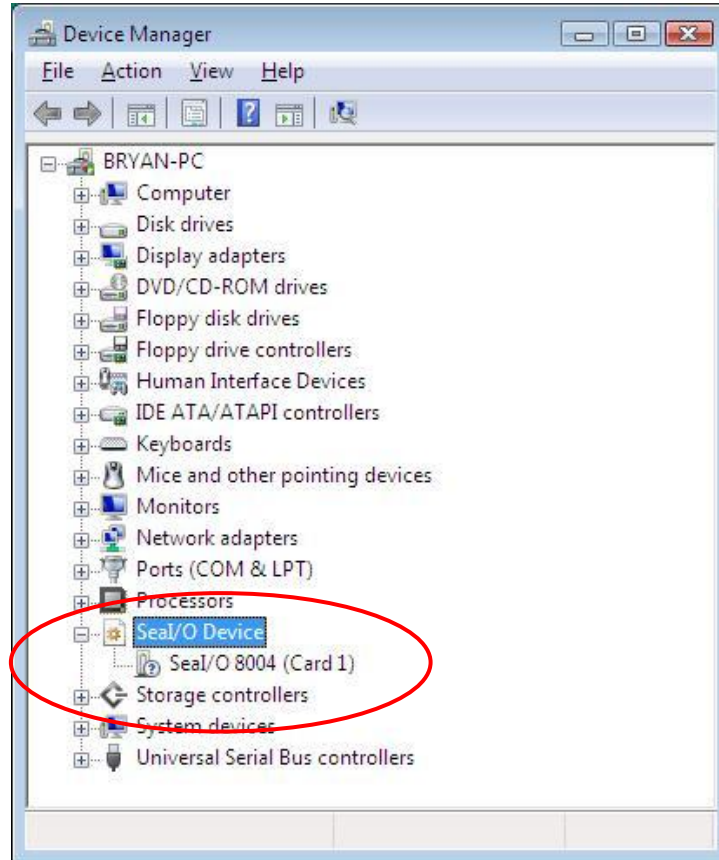

Right click on the adapter line item under the Seal/O Device category and choose 'Properties'. This will show the Properties dialog box, as seen below.

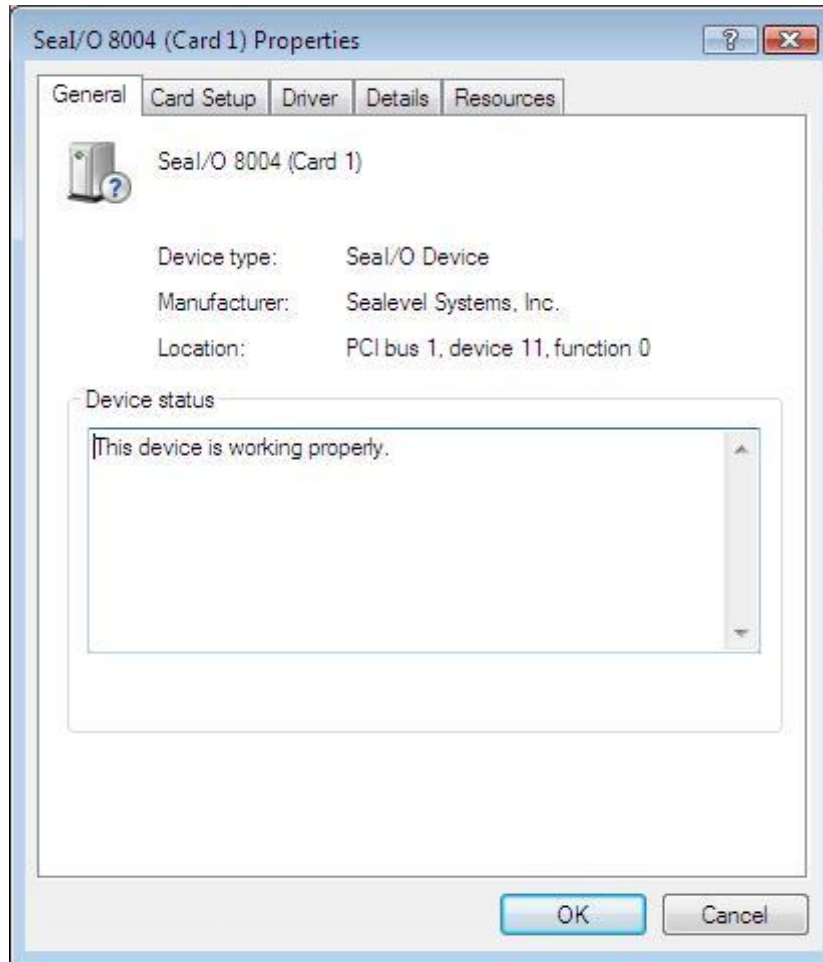

This verifies that the Seal/O digital I/O adapter (8004) is correctly enumerated.

- N** To properly configure your digital I/O adapter, please click on the 'Card Setup' tab and refer to the Configuration section of this manual.

SealO Device Driver Configuration

Configure your Seal/O adapter device driver settings by navigating to the Device Manger and opening the Properties dialog box for the installed Seal/O adapter device.

Choose the Card Setup tab. The example below shows a Seal/O 8004 adapter.

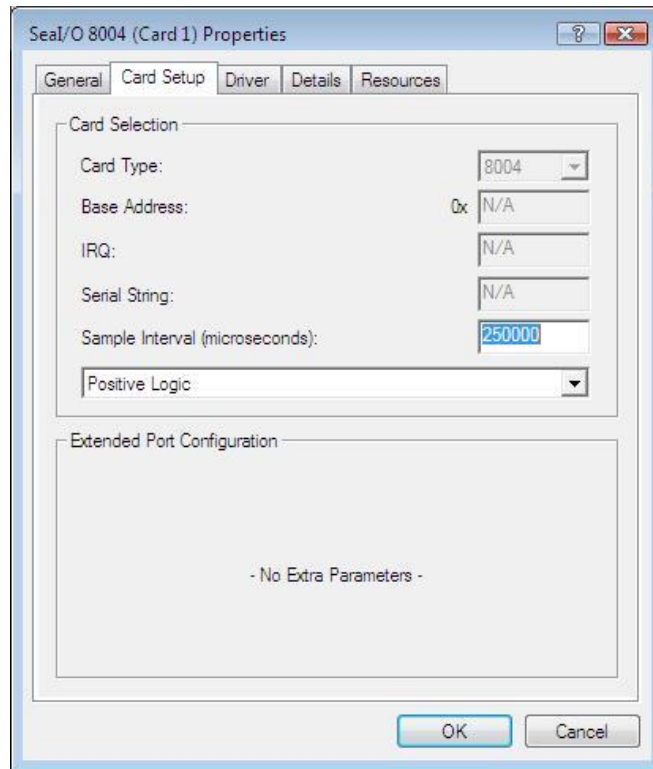

CARD SELECTION CONFIGURATION

Sample Interval

This parameter sets the time interval for the timer used by the device driver to check the adapter for input state changes. To use, your application must invoke the SealO_NotifyInputChange overlapped API device driver call. The default value on installation is 250,000 microseconds (250 milliseconds).



Setting the sampling rate below 10,000 microseconds is not recommend as this can heavily tax the host processor. When the Sample Interval parameter is non-zero, the driver to periodically look at the inputs to see when one changes. When an input changes, the driver will complete the previously issued overlapped call. The driver utilizes a recurring timer to notify it to look at the inputs. The period of time (in microseconds) that occurs between passes of the driver looking at the inputs is specified in the Sample Interval box.

Additional information on Sample Interval can be located in the SealIO Software Information Help file found here: Start - All Programs - SealIO - SealIO Help - Device Configuration.

Logic States

The combo box allows selection of the type of logic that the driver will use: Positive or Negative. The default selection is Positive logic.



The original SealIO API treated devices as if they had active low inputs. This behavior has been revised. The current SealIO API returns inputs as active high.

Legacy SealIO calls are: SealIO_ReadReg and SealIO_WriteReg functions.

Their counterparts are: SealIO_ReadByte, SealIO_WriteByte, SealIO_ReadBit, SealIO_WriteBit, SealIO_WriteAllOutputs and SealIO_ReadAllInputs.

These functions should be used exclusively by new applications.

Positive Logic

PIO cards

Inputs: If the input threshold voltage has not been met the API returns a 0.
If the input threshold voltage has been met the API returns a 1.

Outputs: If a 0 is written to the port the output is 0v.
If a 1 is written to the port the output is 3-5v.

DIO cards

Inputs: If the input threshold voltage has not been met the API returns a 0.
If the input threshold voltage has been met the API returns a 1.

Outputs: If a 0 is written to the port the relay is de-energized.
If a 1 is written to the port the relay is energized.

Negative Logic

PIO cards

Inputs: If the threshold voltage has not been met the API returns a 1.
If the input threshold voltage has been met the API returns a 0.

Outputs: If a 0 is written to the port the output is 3-5v.
If a 1 is written to the port the output is 0v.

DIO cards

Inputs: If the input threshold voltage has not been met the API returns a 1.
If the input threshold voltage has been met the API returns a 0.

Outputs: If a 0 is written to the port the relay is energized.
If a 1 is written to the port the relay is de-energized.

Additional information for Positive and Negative logic choices can be located in the SealO Software Information Help file found here: Start - All Programs - SealO - SealO Help - Logic States.

Appendix B - Handling Instructions

ESD WARNINGS

Electrostatic Discharges (ESD)

A sudden electrostatic discharge can destroy sensitive components. Proper packaging and grounding rules must therefore be observed. Always take the following precautions:

1. Transport boards and cards in electrostatically secure containers or bags.
2. Keep electrostatically sensitive components in their containers, until they arrive at an electrostatically protected workplace.
3. Only touch electrostatically sensitive components when you are properly grounded.
4. Store electrostatically sensitive components in protective packaging or on anti-static mats.

Grounding Methods

The following measures help to avoid electrostatic damages to the device:

1. Cover workstations with approved antistatic material. Always wear a wrist strap connected to a properly grounded workplace.
2. Use antistatic mats, heel straps, and/or air ionizers for more protection.
3. Always handle electrostatically sensitive components by their edge or by their casing.
4. Avoid contact with pins, leads, or circuitry.
5. Turn off power and input signals before inserting and removing connectors or connecting test equipment.
6. Keep work area free of non-conductive materials such as ordinary plastic assembly aids and Styrofoam.
7. Use field service tools such as cutters, screwdrivers, and vacuum cleaners that are conductive.

Appendix C – Example Circuits

INPUT CIRCUIT

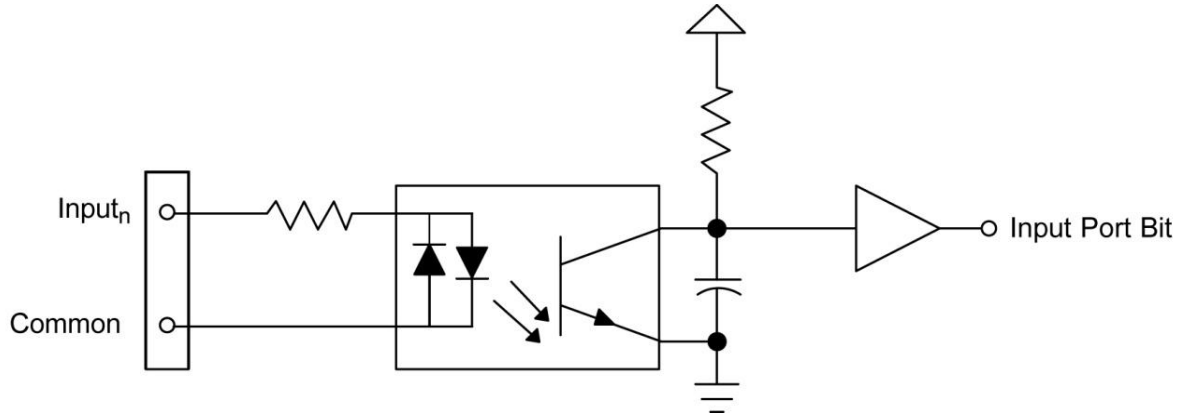

OUTPUT CIRCUIT

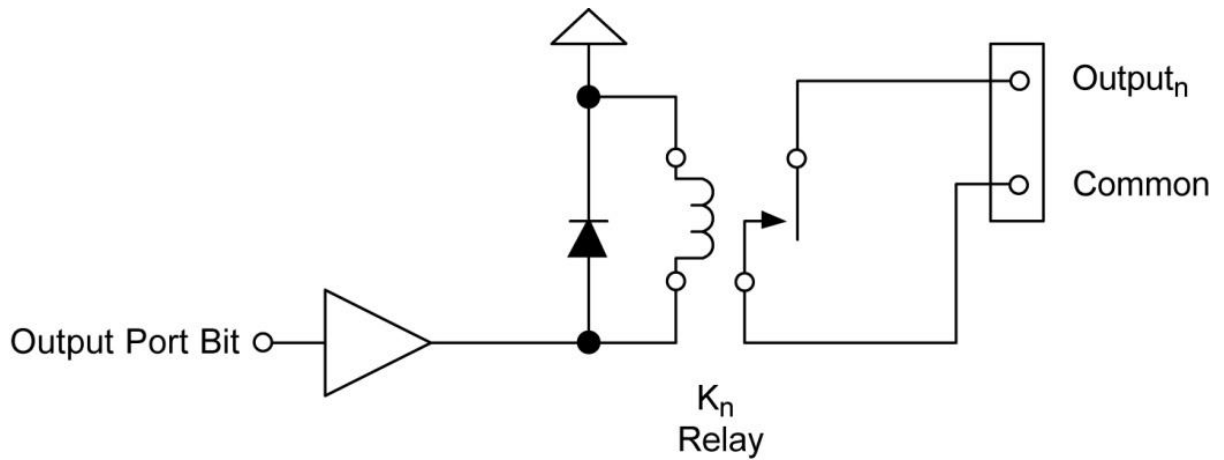

Appendix D – 8012 PCB Drawing

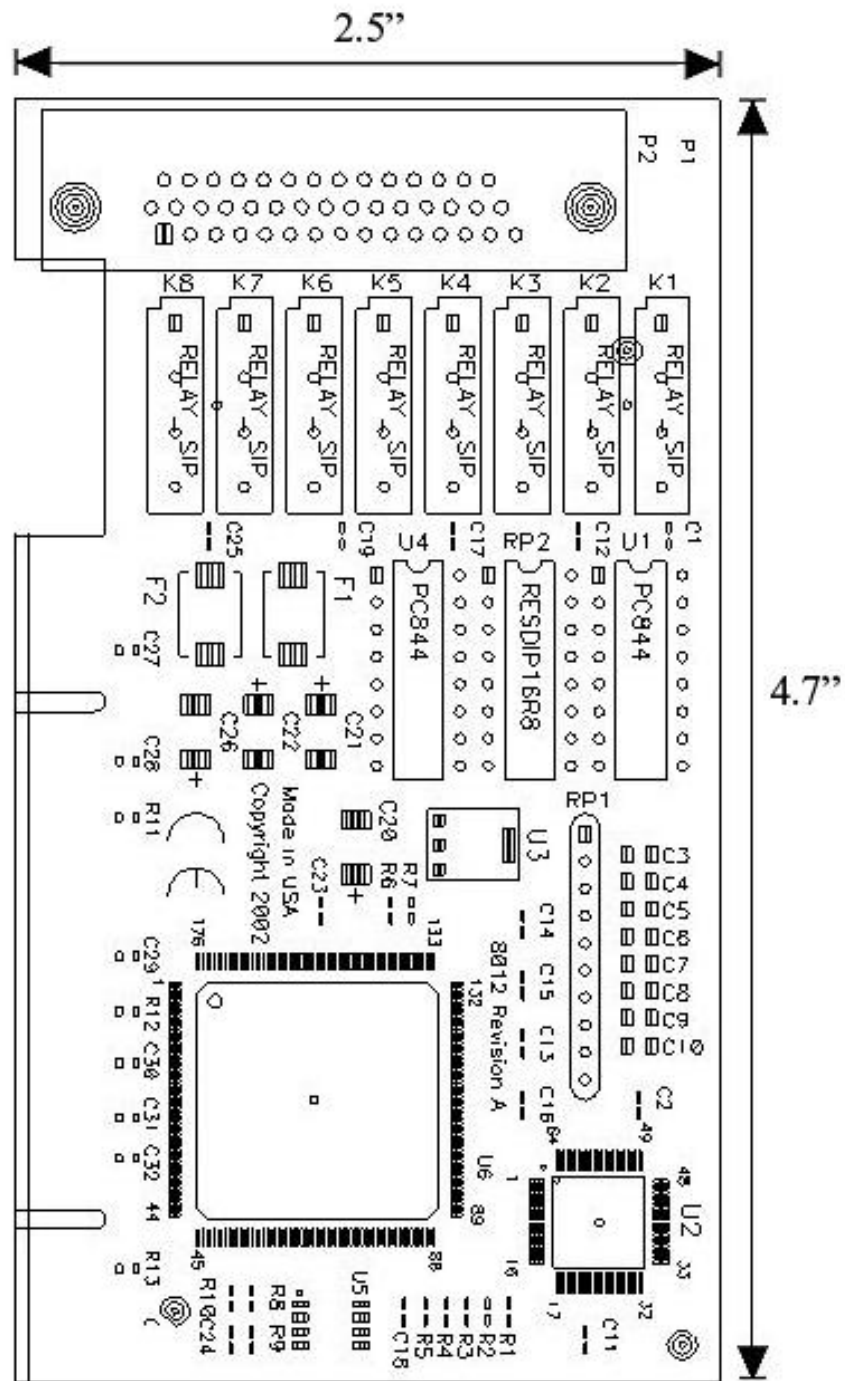

Appendix E - How to Get Assistance

When calling for technical assistance, please have the device installed and ready to run diagnostics. If possible, have your user manual and current settings ready.

The Sealevel website is an excellent resource located at www.sealevel.com. The most current software updates and user manuals are available via our homepage by clicking on the 'Drivers' or 'Manuals' links located under 'Technical Support.' Manuals and software can also be downloaded from the product page for your device.

The FAQ section of our website answers many common questions. Refer to this helpful resource by visiting www.sealevel.com/faq.asp.

TECHNICAL SUPPORT

Monday - Friday
8:00 am to 5:00 pm EST
Phone: +1 (864) 843-4343
Email: support@sealevel.com

Warranty

Sealevel's commitment to providing the best I/O solutions is reflected in the Lifetime Warranty that is standard on all Sealevel manufactured I/O products. Relio™ industrial computers are warranted for a period of two years and the Relio™ R9 family is warranted for a five year period from date of purchase. We are able to offer this warranty due to our control of manufacturing quality and the historically high reliability of our products in the field. Sealevel products are designed and manufactured at its Liberty, South Carolina facility, allowing direct control over product development, production, burn-in and testing. Sealevel achieved ISO-9001:2000 certification in 2002.

WARRANTY POLICY

Sealevel Systems, Inc. (hereafter "Sealevel") warrants that the Product shall conform to and perform in accordance with published technical specifications and shall be free of defects in materials and workmanship for the warranty period. In the event of failure, Sealevel will repair or replace the product at Sealevel's sole discretion. Failures resulting from misapplication or misuse of the Product, failure to adhere to any specifications or instructions, or failure resulting from neglect, abuse, accidents, or acts of nature are not covered under this warranty.

Warranty service may be obtained by delivering the Product to Sealevel and providing proof of purchase. Customer agrees to insure the Product or assume the risk of loss or damage in transit, to prepay shipping charges to Sealevel, and to use the original shipping container or equivalent. Warranty is valid only for original purchaser and is not transferable.

This warranty applies to Sealevel manufactured Product. Product purchased through Sealevel but manufactured by a third party will retain the original manufacturer's warranty.

NON-WARRANTY REPAIR/RETEST

Products returned due to damage or misuse and Products retested with no problem found are subject to repair/retest charges. A purchase order or credit card number and authorization must be provided in order to obtain an RMA (Return Merchandise Authorization) number prior to returning Product.

HOW TO OBTAIN AN RMA (RETURN MERCHANDISE AUTHORIZATION)

If you need to return a product for warranty or non-warranty repair, you must first obtain an RMA number. Please contact Sealevel Systems, Inc. Technical Support for assistance:

Available	Monday – Friday, 8:00AM to 5:00PM EST
Phone	864-843-4343
Email	support@sealevel.com