

User Manual

Keysight Instrument Rack

E7590A- 1.3 m

E3661B- 1.6 m

E3662B- 2.0 m

Notices

© Keysight Technologies, Inc. 2015

No part of this manual may be reproduced in any form or by any means (including electronic storage and retrieval or translation into a foreign language) without prior agreement and written consent from Keysight Technologies, Inc. as governed by United States and international copyright laws.

Manual Part Number

5967-9318

Edition

Third Edition, August 2015

Printed in

Malaysia

Published by

Keysight Technologies, Inc.
900 S. Taft Ave.
Loveland, CO 80537 USA

Trademarks

PICMG[®], Compact PCI[®] are registered trademarks of the PCI Industrial Computer Manufacturers Group.

AdvancedTCA[®] and ATCA are registered trademarks of the PCI Industrial Computer Manufacturers Group.

PCI-SIG[®], PCI Express[®], and PCIe[®] are registered trademarks of PCI-SIG.

Technology Licenses

The hardware and/or software described in this document are furnished under a license and may be used or copied only in accordance with the terms of such license.

Declaration of Conformity

Declarations of Conformity for this product and for other Keysight products may be downloaded from the Web. Go to <http://keysight.com/go/conformity>.

You can then search by product number to find the latest Declaration of Conformity.

U.S. Government Rights

The Software is “commercial computer software,” as defined by Federal Acquisition Regulation (“FAR”) 2.101. Pursuant to FAR 12.212 and 27.405-3 and Department of Defense FAR Supplement (“DFARS”) 227.7202, the U.S. government acquires commercial computer software under the same terms by which the software is customarily provided to the public. Accordingly, Keysight provides the Software to U.S. government customers under its standard commercial license, which is embodied in its End User License Agreement (EULA), a copy of which can be found at <http://www.keysight.com/find/sweula>. The license set forth in the EULA represents the exclusive authority by which the U.S. government may use, modify, distribute, or disclose the Software. The EULA and the license set forth therein, does not require or permit, among other things, that Keysight: (1) Furnish technical information related to commercial computer software or commercial computer software documentation that is not customarily provided to the public; or (2) Relinquish to, or otherwise provide, the government rights in excess of these rights customarily provided to the public to use, modify, reproduce, release, perform, display, or disclose commercial computer software or commercial computer software documentation. No additional government requirements beyond those set forth in the EULA shall apply, except to the extent that those terms, rights, or licenses are explicitly required from all providers of commercial computer software pursuant to the FAR and the DFARS and are set forth specifically in writing elsewhere in the EULA. Keysight shall be under no obligation to update, revise or otherwise modify the Software. With respect to any technical data as defined by FAR 2.101, pursuant to FAR 12.211 and 27.404.2 and DFARS 227.7102, the U.S. government acquires no greater than Limited Rights as defined in FAR 27.401 or DFAR 227.7103-5 (c), as applicable in any technical data.

Warranty

THE MATERIAL CONTAINED IN THIS DOCUMENT IS PROVIDED “AS IS,” AND IS SUBJECT TO BEING CHANGED, WITHOUT NOTICE, IN FUTURE EDITIONS. FURTHER, TO THE MAXIMUM EXTENT PERMITTED BY APPLICABLE LAW, KEYSIGHT DISCLAIMS ALL WARRANTIES, EITHER EXPRESS OR IMPLIED, WITH REGARD TO THIS MANUAL AND ANY INFORMATION CONTAINED HEREIN, INCLUDING BUT NOT LIMITED TO THE IMPLIED WARRANTIES OF MERCHANTABILITY AND FITNESS FOR A PARTICULAR PURPOSE. KEYSIGHT SHALL NOT BE LIABLE FOR ERRORS OR FOR INCIDENTAL OR CONSEQUENTIAL DAMAGES IN CONNECTION WITH THE FURNISHING, USE, OR PERFORMANCE OF THIS DOCUMENT OR OF ANY INFORMATION CONTAINED HEREIN. SHOULD KEYSIGHT AND THE USER HAVE A SEPARATE WRITTEN AGREEMENT WITH WARRANTY TERMS COVERING THE MATERIAL IN THIS DOCUMENT THAT CONFLICT WITH THESE TERMS, THE WARRANTY TERMS IN THE SEPARATE AGREEMENT SHALL CONTROL.

Keysight Technologies does not warrant third-party system-level (combination of chassis, controllers, modules, etc.) performance, safety, or regulatory compliance unless specifically stated.

Safety Information

CAUTION

A CAUTION denotes a hazard. It calls attention to an operating procedure or practice that, if not correctly performed or adhered to, could result in damage to the product or loss of important data. Do not proceed beyond a CAUTION notice until the indicated conditions are fully understood and met.

WARNING

A WARNING denotes a hazard. It calls attention to an operating procedure or practice, that, if not correctly performed or adhered to, could result in personal injury or death. Do not proceed beyond a WARNING notice until the indicated conditions are fully understood and met.

Safety Information

The following general safety precautions must be observed during all phases of operation of this instrument. Failure to comply with these precautions or with specific warnings or operating instructions in the product manuals violates safety standards of design, manufacture, and intended use of the instrument. Keysight Technologies assumes no liability for the customer's failure to comply with these requirements.

General

Do not use this product in any manner not specified by the manufacturer. The protective features of this product must not be impaired if it is used in a manner specified in the operation instructions.

Before Applying Power

Verify that all safety precautions are taken. Make all connections to the unit before applying power. Note the external markings described under "Safety Symbols".

Ground the Instrument

Keysight chassis' are provided with a grounding-type power plug. The instrument chassis and cover must be connected to an electrical ground to minimize shock hazard. The ground pin must be firmly connected to an electrical ground (safety ground) terminal at the power outlet. Any interruption of the protective (grounding) conductor or disconnection of the protective earth terminal will cause a potential shock hazard that could result in personal injury.

Do Not Operate in an Explosive Atmosphere

Do not operate the module/chassis in the presence of flammable gases or fumes.

Do Not Operate Near Flammable Liquids

Do not operate the module/chassis in the presence of flammable liquids or near containers of such liquids.

Cleaning

Clean the outside of the Keysight module/chassis with a soft, lint-free, slightly dampened cloth. Do not use detergent or chemical solvents.

Do Not Remove Instrument Cover

Only qualified, service-trained personnel who are aware of the hazards involved should remove instrument covers. Always disconnect the power cable and any external circuits before removing the instrument cover.

Keep away from live circuits

Operating personnel must not remove equipment covers or shields. Procedures involving the removal of covers and shields are for use by service-trained personnel only. Under certain conditions, dangerous voltages may exist even with the equipment switched off. To avoid dangerous electrical shock, DO NOT perform procedures involving cover or shield removal unless you are qualified to do so.

DO NOT operate damaged equipment

Whenever it is possible that the safety protection features built into this product have been impaired, either through physical damage, excessive moisture, or any other reason, REMOVE POWER and do not use the product until safe operation can be verified by service-trained personnel. If necessary, return the product to an Keysight Technologies Sales and Service Office for service and repair to ensure the safety features are maintained.

DO NOT block the primary disconnect

The primary disconnect device is the appliance connector/power cord when a chassis used by itself, but when installed into a rack or system the disconnect may be impaired and must be considered part of the installation.

Do Not Modify the Instrument

Do not install substitute parts or perform any unauthorized modification to the product. Return the product to an Keysight Sales and Service Office to ensure that safety features are maintained.

In Case of Damage

Instruments that appear damaged or defective should be made inoperative and secured against unintended operation until they can be repaired by qualified service personnel

CAUTION

Do NOT block vents and fan exhaust: To ensure adequate cooling and ventilation, leave a gap of at least 50mm (2") around vent holes on both sides of the chassis.

Do NOT operate with empty slots: To ensure proper cooling and avoid damaging equipment, fill each empty slot with an AXle filler panel module.

Do NOT stack free-standing chassis: Stacked chassis should be rack-mounted.

All modules are grounded through the chassis: During installation, tighten each module's retaining screws to secure the module to the chassis and to make the ground connection.

WARNING

Operator is responsible to maintain safe operating conditions. To ensure safe operating conditions, modules should not be operated beyond the full temperature range specified in the Environmental and physical specification. Exceeding safe operating conditions can result in shorter lifespan, improper module performance and user safety issues. When the modules are in use and operation within the specified full temperature range is not maintained, module surface temperatures may exceed safe handling conditions which can cause discomfort or burns if touched. In the event of a module exceeding the full temperature range, always allow the module to cool before touching or removing modules from the chassis.

Safety Symbols







CAUTION

A CAUTION denotes a hazard. It calls attention to an operating procedure or practice, that, if not correctly performed or adhered to could result in damage to the product or loss of important data. Do not proceed beyond a CAUTION notice until the indicated conditions are fully understood and met.

WARNING

A WARNING denotes a hazard. It calls attention to an operating procedure or practice, that, if not correctly performed or adhered to, could result in personal injury or death. Do not proceed beyond a WARNING notice until the indicated conditions are fully understood and met.

Products display the following symbols:

-  Warning, risk of electric shock
-  Refer to manual for additional safety information.
-  Earth Ground.
-  Chassis Ground.
-  Alternating Current (AC).
-  Standby Power. Unit is not completely disconnected from AC mains when switch is in standby.
-  Antistatic precautions should be taken.
- CAT I IEC Measurement Category I, II, III, or IV
- CAT II
- CAT III
- CAT IV

For localized Safety Warnings, Refer to Keysight Safety document (p/n 9320-6792).



The CSA mark is a registered trademark of the Canadian Standards Association and indicates compliance to the standards laid out by them. Refer to the product Declaration of Conformity for details.



Notice for European Community: This product complies with the relevant European legal Directives: EMC Directive (2004/108/EC) and Low Voltage Directive (2006/95/EC).



The Regulatory Compliance Mark (RCM) mark is a registered trademark. This signifies compliance with the Australia EMC Framework regulations under the terms of the Radio Communication Act of 1992.

ICES/NMB-001

ICES/NMB-001 indicates that this ISM device complies with the Canadian ICES-001.



This symbol represents the time period during which no hazardous or toxic substance elements are expected to leak or deteriorate during normal use. Forty years is the expected useful life of this product.



South Korean Class A EMC Declaration. This equipment is Class A suitable for professional use and is for use in electromagnetic environments outside of the home.

A 급 기기 (업무용 방송통신기자재) 이 기기는 업무용 (A 급) 전자파적합기기로서 판매자 또는 사용자는 이 점을 주의하시기 바라 며 , 가정외의 지역에서 사용하는 것을 목적으로 합니다.



Waste Electrical and Electronic Equipment (WEEE) Directive 2002/96/EC

This product complies with the WEEE Directive (2002/96/EC) marking requirement. The affixed product label (see below) indicates that you must not discard this electrical/electronic product in domestic household waste.

Product Category: With reference to the equipment types in the WEEE directive Annex 1, this product is classified as a "Monitoring and Control instrumentation" product.

Do not dispose in domestic household waste.

To return unwanted products, contact your local Keysight office for more information.



Contents

Safety and Regulatory Information	7
Safety Warnings	7
Grounding	7
Leakage Current	8
Power Limitations	8
Cabinet Stability	8
Acoustics - (Germany)	8
Accessories	9
Intended Use of Equipment	9
Cleaning	9
Description	10
Electrical and Environmental Specifications	10
Physical Specifications	11
Dimensions	12
Ventilation and Heat Dissipation	15
Cable Access	16
Standard Racks	16
Top	16
Side Panels	16
Rear Door	17
Mounting Columns	17
Support Rails	18
Rack Lifting Hooks	18
Anti-tip Stabilizer	19
Casters	19
Levelers	19
PDU	19
PDU Install Kit	19
Extractor Fan	19
Filler Panels	20
Ballast	20
Monitor Mount Kit	20
Support Rails	20
VXI Rail	20
Non-Keysight Rail	21
Set Up	22
Floor Space and Loading	22
Rack Space	22
Equipment Installation Guidelines	22
Cooling	23
Weight and Balance	24
Slide-Mounted Products	24
Work Surface/Keyboard	25
Acoustic Considerations	27
Estimating Total Noise	28
Procedures	29
Receiving	29

Unpacking and Handling	29
Repackaging the Rack for Shipment	32
Removal and Replacement	33
Rear Door Removal	33
Rear Door Replacement	33
Top Cap Removal	33
Top Cap Replacement	33
Side Cover Removal	34
Side Cover Replacement	34
Forehead Assembly Removal	34
Forehead Assembly Replacement	34
Base Cover Removal	35
Base Cover Replacement	35
Anti-tip Stabilizer Removal	35
Anti-tip Stabilizer Replacement	35
Rear Door Hinge Removal	35
Rear Door Hinge Replacement	36
Rail Removal	36
Rail Replacement	36
Leveler or Caster Removal	36
Leveler or Caster Replacement	37
Ballast Removal	37
Ballast Replacement	37
Door Bumper	37

Safety and Regulatory Information

For your protection, this product has been tested for conformance to various national and international regulations and standards. The scope of this regulatory testing includes electrical and mechanical safety, electromagnetic emissions, immunity, ESD, acoustics, and hazardous materials.

Where required, certifications are obtained from third party test agencies. Certification marks appear on the product label. In addition, various regulatory bodies require information under the headings below.

Please refer to the *Safety Information* guide provided with the instrument rack for additional important information.

This product and related documentation must be reviewed for familiarization with safety markings and instructions before operation.

WARNING

The **WARNING** sign denotes a hazard. It calls attention to a procedure, practice, or situation which, if not done correctly or adhered to, could result in injury. Do not proceed beyond a **WARNING** sign until the indicated conditions are fully understood and met.

CAUTION

The **CAUTION** sign denotes a hazard. It calls attention to an operating procedure, practice, or situation which, if not done correctly or adhered to, could damage or destroy part or the entire product. Do not proceed beyond a **CAUTION** sign until the indicated conditions are fully understood and met.

Safety Warnings

The following warnings and cautions are applicable to all Keysight racks. Please observe all safety precautions and warnings.

Grounding

This product has not been evaluated for connection to an IT power system, an AC distribution system having no direct connection to earth (ground), according to EN60950.

WARNING

This is a safety class I product and has a protective earthing (grounding) terminal. There must be an un-interruptible safety earth ground from the main power source to the product's input wiring terminals, power cord, or supplied cord set. Whenever it is likely that the protection has been impaired, disconnect the power cord until the ground has been restored.

Leakage Current

WARNING

Due to types of products that can be installed in this cabinet, there is a risk of high leakage current (3.5 mA). Reliable ground circuit continuity is vital for safe operation of this product. To reduce the risk of electric shock, earth (ground) connection is essential before connecting the power supply. Never operate this cabinet with the ground conductor disconnected.

Power Limitations

CAUTION

To reduce the risk of overload, do not load any single PDU with more than a maximum of 16 Amperes. In addition, do not load a single NEMA 5-15 or IEC-320 receptacle with more than 15 Amperes.

Cabinet Stability

WARNING

To reduce the risk of cabinet instability, install counter ballast at the bottom-rear of the cabinet before installing any computer components.

CAUTION

To reduce the risk of cabinet instability, fully extend the stabilizer before extending any devices. Extend only one device at a time. Do not stand or sit on any extended device. Qualified service personnel should do all non-operator servicing.

Acoustics - (Germany)

Acoustic noise (a weighted sound pressure level LpA) measured at the operator's position, normal operation to ISO 7779.

Laemangabe (Schalldruckpegel LpA) gemessen an Arbeitsplatz bei normalem Betrieb nach DIN 45635, Teil 19.

Accessories

With extractor fan accessory: 61 dB (LpA) For information about rack accessories and compatibility, see the *Keysight Enclosures Solutions Product Catalog* at www.keysight.com/find/racks on the Web, or contact your Keysight Sales Representative.

This product is designed for use with specific electrical accessories (i.e., PDUs and fans). The use of any other accessory is not recommended or supported.

CAUTION

This product is designed for use with specific electrical accessories (i.e., PDUs and fans). The use of any other accessory is not recommended or supported.

WARNING

Do not attempt to open or repair the Power Distribution Unit (PDU). There are no replaceable parts inside the PDU. If the power cord or switch cord is frayed, cut, or damaged, replace the entire PDU.

Intended Use of Equipment

The Keysight E7590A, E3661B, and E3662B Instrument Racks are intended to be used, along with the recommended accessories, for the installation of standard 19-inch rack mounted instruments from Keysight and other manufacturers.

Cleaning

Disconnect the power from the instrument rack before cleaning the instrument rack and accessories. Use only a damp cloth to clean the surfaces of the instrument rack and accessories.

Description

The Keysight 19-inch Electronics Industries Association (EIA) racks, options, and accessories are designed specifically to meet the needs of instrumentation customers and make installing devices in rack mounting systems simple.

The instrument racks consist of a welded, cold-rolled steel frame with removable top, sides, and rear door, casters, leveling feet and an anti-tipping mechanism as shown in Figure 1. Internally, rails that hold your equipment lock into slots in the vertical mounting columns. These plus keyed slots provide for quick and accurate placement.

Electrical and Environmental Specifications

The electrical and environmental specifications for the instrument racks, shown in the table below, depend on the power distribution unit (PDU) option selected:

Option AW1:No PDU

Option AW3:100-120V, 50/60 Hz PDU Option AW5:200-240V, 50/60 Hz PDU

Model Number	E3661B-AW1 E3662B-AW1 E7590A-AW1	E7590A-AW3	E7590A-AW5	E3661B-AW3 E3662B-AW3	E3661B-AW5 E3662B-AW5
Input	-	100-120V, 50/60 Hz	200-240V, 50/60 Hz	100-120V, 50/60 Hz	200-240V, 50/60 Hz
Output	-	100-120V, 50/60 Hz, 16A 1-IEC 320 C13 Receptacle	200-240V, 50/60 Hz, 16A 6-IEC 320 C13 Receptacles	100-120V, 50/60 Hz, 16A 1-IEC 320 C13 Receptacle	200-240V, 50/60 Hz, 16A 1-IEC 320 C19 10-IEC 320 C13 Receptacles
Operating Temperature	0° C to 55° C	0° C to 55° C	0° C to 55° C	0° C to 55° C	0° C to 55° C
Operating Humidity	5% to 80% RH, non- condensing	5% to 80% RH, non- condensing	5% to 80% RH, non- condensing	5% to 80% RH, non- condensing	5% to 80% RH, non- condensing
Operating Environment	Indoor Location	Indoor Location	Indoor Location	Indoor Location	Indoor Location

NOTE

100-120V, 50/60 Hz racks (Option AW3) are supplied with a power cord terminated with a NEMA 5-20P plug to fit a 20A receptacle.

200-240V, 50/60 Hz racks (Option AW5) are supplied without a power plug—the PDU power cord is un-terminated. The installer must install the correct plug for the country of installation.

All racks (Option AW3 or AW5) must be connected to a dedicated 20A circuit.

Physical Specifications

The physical specifications for the racks are listed below.

Rack	Height	Width	Depth	Weight
E7590A	1.3 m / 51.9 in	.6 m/23.6 in	.905 m/35.6 in	140.6 kg/310 lbs
E3661B	1.6 m / 63.8 in	.6 m/23.6 in	.905 m/35.6 in	161 kg/355 lbs
E3662B	2.0 m / 79.5 in	.6 m/23.6 in	.905 m/35.6 in	177 kg/390 lbs

All rack models can be loaded with a total of 1800 pounds of equipment.

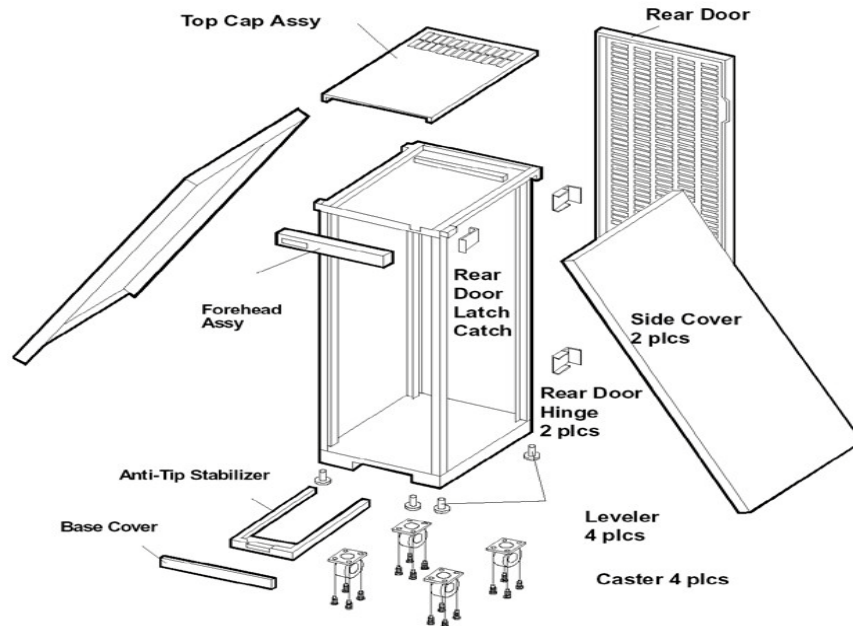

Figure 1 Exploded view of Keysight Rack

Dimensions

The side view in Figure 2 shows valid dimensions for the E7590A, E3661B and E3662B.

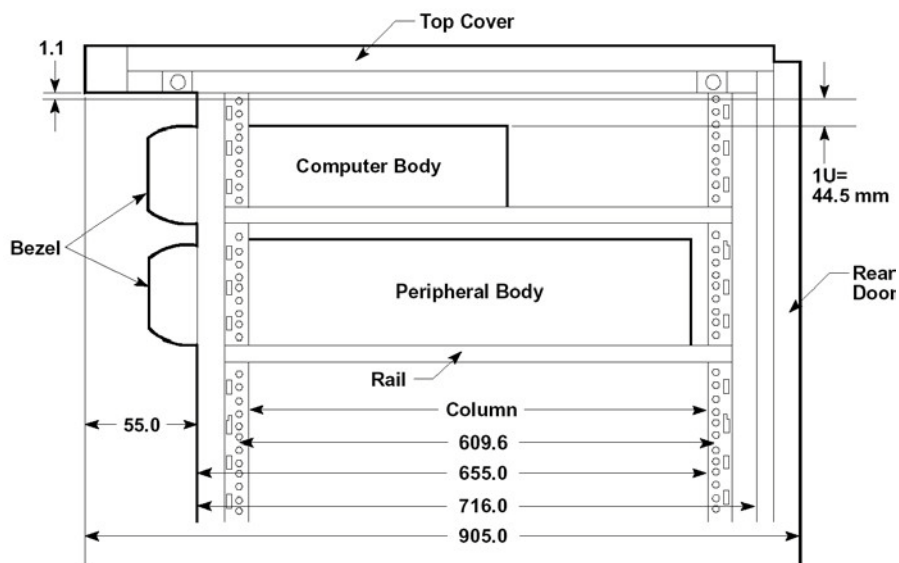

Figure 2 Side View of Top of Rack with Installed Components

The dimensions of the E7590A are shown in Figures 3. All dimensions are in millimeters.

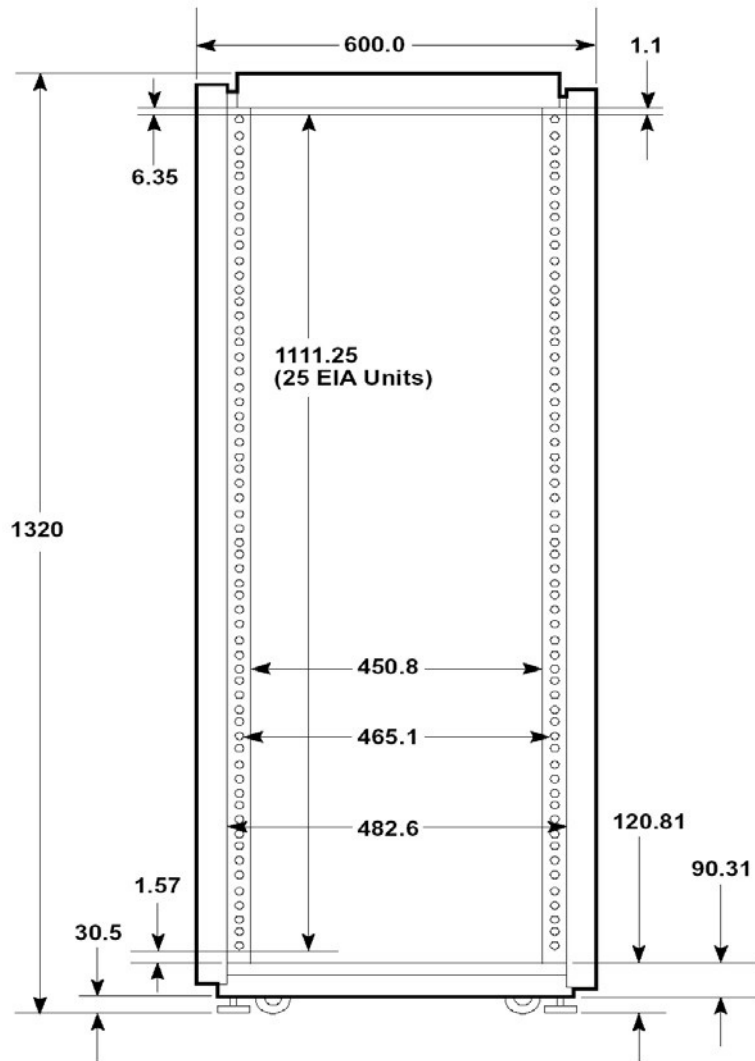

Figure 3 E7590A Dimensions – Front View

The dimensions of the E3661B are shown below.

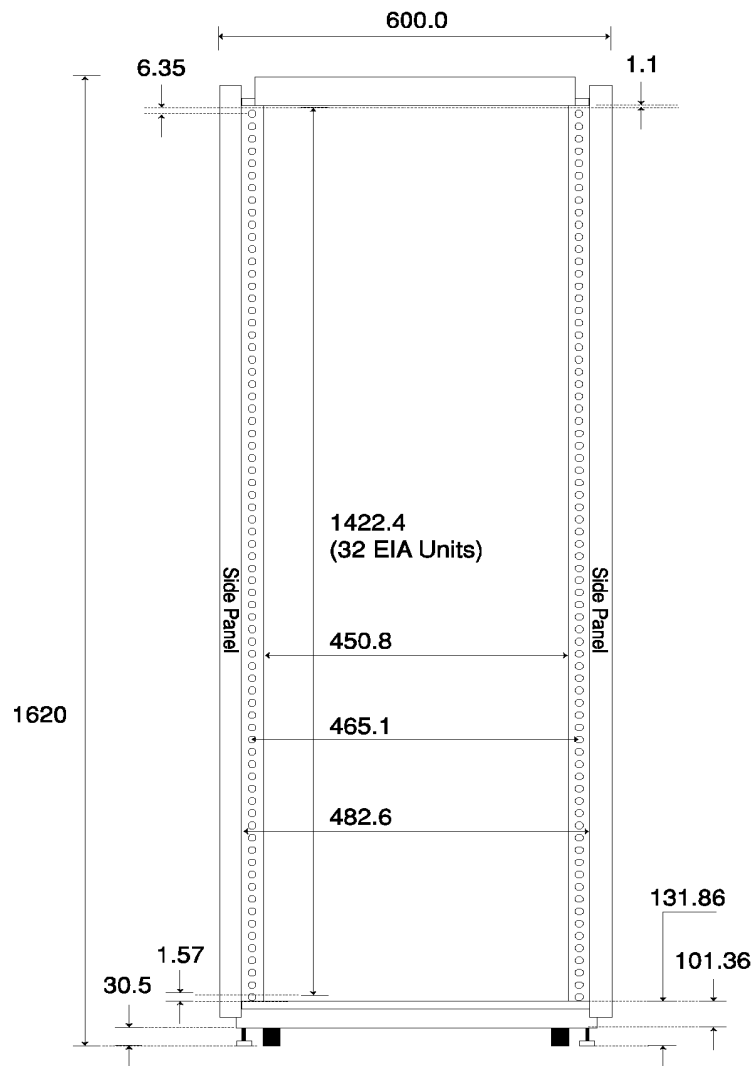

Figure 4 E3661B Dimensions— Front View

The dimensions of the E3662B are shown below.

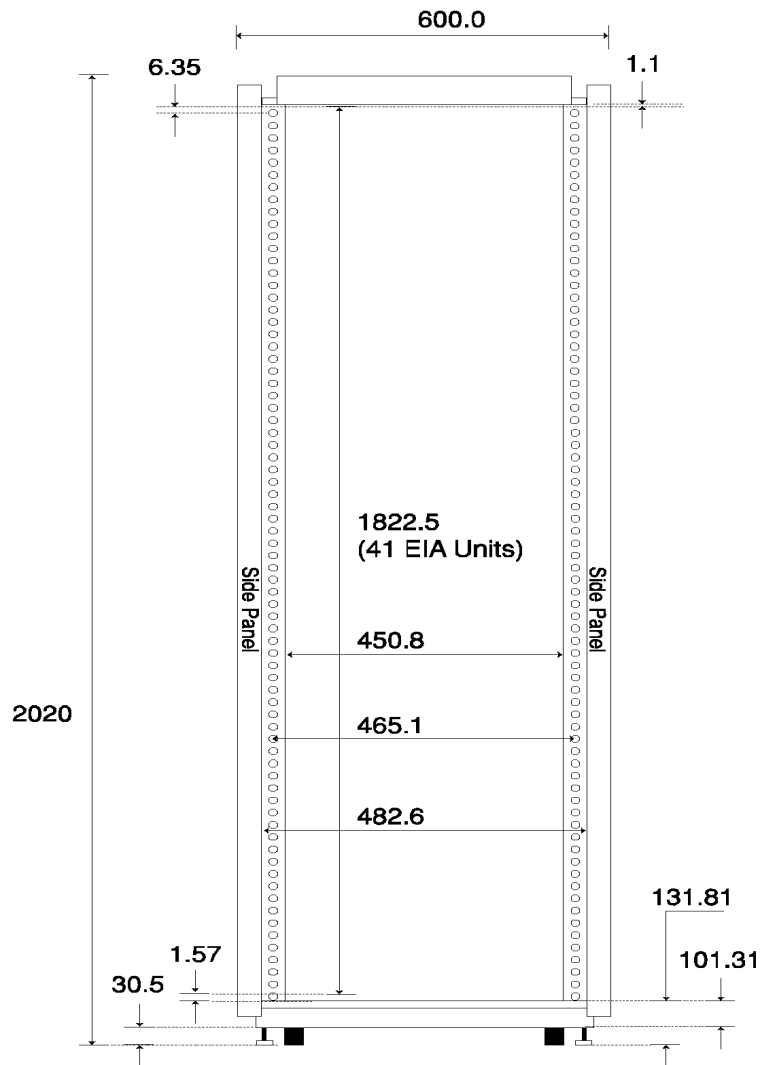

Figure 5 E3662 Dimensions— Front View

Ventilation and Heat Dissipation

Air is primarily drawn through the opening at the bottom of the rear door. Through convection, the heated air rises to the exhaust. By either simple convection, or a combination with an optional extractor fan, the heated air exhausts through the vented top cap, illustrated in Figure 6.

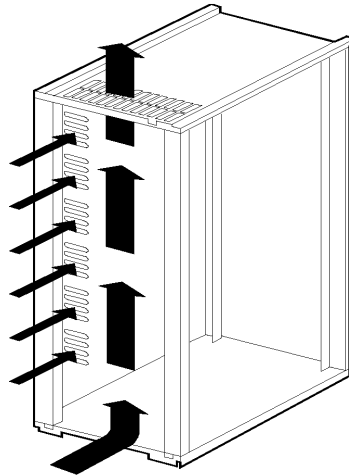

Figure 6 Air Flow through the rack.

When the proper system is installed, internal temperature rise is typically less than 15 °C (27 ° F) over ambient temperature.

NOTE

Keysight recommends that you monitor the internal temperature of the rack. The internal temperature should not exceed the heat rating of any installed instruments.

Cable Access

The base of the rack stops 100 mm short of the rear door, providing an access path for power and signal cables.

Standard Racks

The following parts are included with every Keysight instrument rack.

Top

The top of the rack incorporates a ventilation path through the roof of the rack and the convection current heat exit for the heat generated by the installed equipment.

Side Panels

Lift up-and-off side panels allow fast and easy access from either side for installation, servicing, and removal of equipment. The top cap need not be removed to remove side panels.

Rear Door

Standard is a right-opening, vented rear door with a lockable slam latch and sheet metal catch providing ventilation and security. The rear door can be mounted to open from either the left or the right.

Mounting Columns

The rack columns are a folded design. Running up the inside of the fold is rectangular mounting slots for the rails, in screw holes for securing the rails. The hole placement is chosen to conveniently place EIA racks. Every fifth rectangular hole is slotted to make counting easier. See Figure 7.

The mounting columns bolt into the corners of the frame, and then accept supporting rails into pre-configured mounting slots. Each of two rails attaches between the front and rear columns. The equipment is then mounted on a pair of support rails that run from front to back.

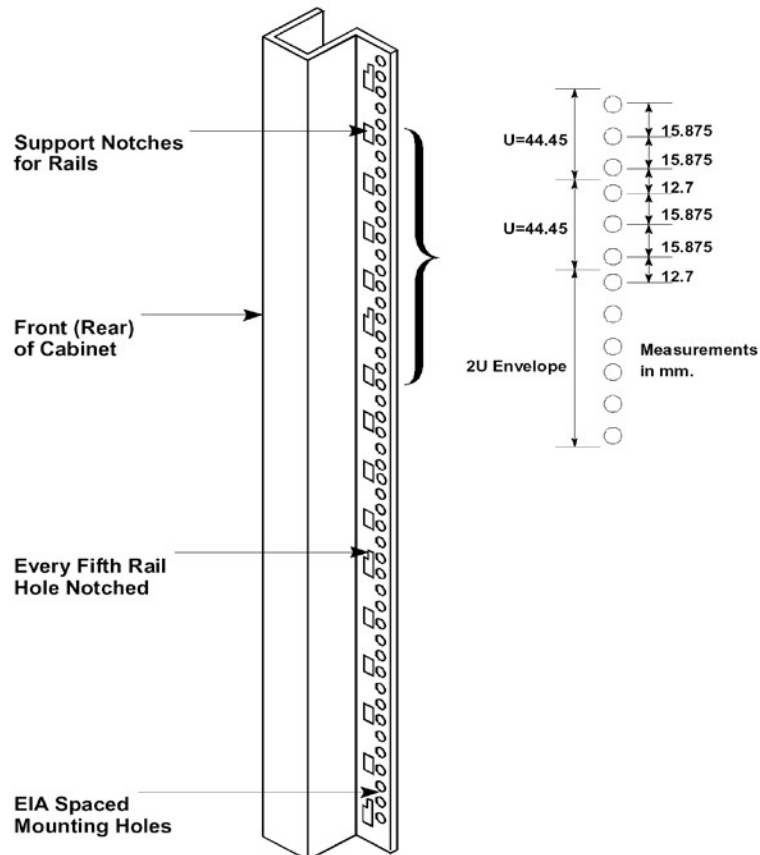

Figure 7 Vertical Mounting Columns

Each product or device installed requires one or more EIA unit increments. One standard EIA rack mount increment is equal to 44.45 mm (1.75 in).

Support Rails

Equipment is supported in the rack by support rails running from front to back. The rails are screwed to the vertical columns. See Figure 7 for an illustration of a System II rail. System II rails are used with any instrument that conforms to Keysight System II product specifications, and are the standard support rail.

Only after securing a pair of rails with screws can equipment be installed.

The mounting slots in the columns are positioned to make support rail placement convenient in EIA units. Additionally, they are marked to make matching the heights of matching support rails easy.

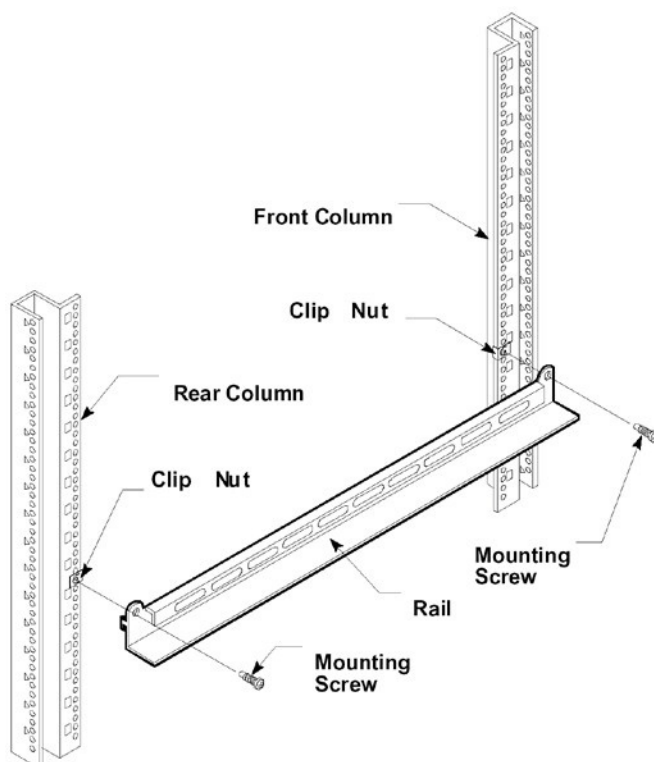

Figure 8 System II Rail with Support Columns and Attaching Hardware

Rack Lifting Hooks

Four lifting hooks are fitted to the top of the rack. Together, they can support the weight of a rack loaded to maximum recommend gross weight. Each hook is capable of supporting 227 kg (500 lbs). Maximum recommended gross weight is 816 kg (1800 lbs).

Anti-tip Stabilizer

Standard on each Keysight rack is a retractable anti-tip stabilizer mechanism. Located at the bottom center of the rack, it provides temporary additional stability when installing or removing equipment components. The anti-tip stabilizer should also be used when slide-mounted components are in their extended position.

WARNING

The stability work sheets should be used whenever a new system is configured, or a change to a system is made, to assure rack stability.

NOTE

Use the ballast accessory (P/N C2790A) when permanent additional stability is required. See the worksheets in Appendix A to determine your ballast requirements.

Casters

Each Keysight rack is provided with four, 3-inch diameter, smooth rolling, heavy-duty casters to facilitate moves over short distances.

CAUTION

A fully loaded cabinet's maximum gross weight of 816kg (1800 lbs) can overload a raised floor.

Levelers

Levelers are located in each corner to level and stabilize the rack. For maximum accuracy, use a level while adjusting the feet.

PDU

A 110V (option AW3) or 220V (option AW5) PDU can be ordered with each rack. A maximum of two PDUs can be installed in one rack.

PDU Install Kit

A PDU installation kit is installed at the factory for the above PDU – each installation kit has the capability for installation of a second PDU. A second PDU can be ordered and installed by the customer.

Extractor Fan

An extractor fan assembly can be ordered and consists of two 100 cubic feet per minute tube-axial fans attached to a fan tray. The fan assembly is attached to the top-rear of the rack frame.

Filler Panels

To ensure adequate cooling in racks using extractor fans, all unused front panel space must be covered with blank filler panels and the rear door must be closed.

Filler panels are made from 1.57 mm (0.062 in) aluminum formed to give the thickness of standard 4.7 (0.187 in) distance from the panel mounting flange. The panels are supplied with EIA/IEC mounting holes and attaching hardware.

The filler panels are designed for use with the rack with EIA/IEC mounting holes and attaching hardware. They can be ordered in 7 different sizes measured in EIA units, mm, or in.

Ballast

Ballast is available in 30 lb. kits, and may be required when using slide-mounted products and/or keyboard/work surface products. Use the stability work sheets in the Procedures chapter to determine ballast requirements.

CAUTION

Do not ship racks with ballast installed.

CAUTION

Always mount ballast in the rear of the rack.

NOTE

The anti-tip assembly is not a substitute for ballast.

Monitor Mount Kit

An optional monitor mounting kit is available.

Support Rails

Two optional support rail types are available.

VXI Rail

VXI rails are used with Keysight VXI mainframe equipment.

Non-Keysight Rail

Non-Keysight rails are used with any non-Keysight products that mount at the bottom of the EIA envelope. The Non-Keysight rails extend lower into the EIA envelope than the standard and the VXI rails.

Set Up

This chapter defines the floor loading requirements and set up guidelines.

Floor Space and Loading

Observe floor loading requirements (especially raised floors) and ensure adequate space before moving your Keysight rack, and all safety items while moving.

At maximum gross weight, the floor must be able to support 677-kg/ sq cm (2000 lb./sq in).

WARNING

It is the customer's responsibility to determine the floor loading capacities at the installation site, and for the entire route when moving. Failure to do so could result in personal injury and/or equipment damage.

Because the weight is concentrated on the four casters, a maximum weight rack requires a reinforced floor. Keysight Technologies recommends removing components and moving them separately when moving a rack over a floor (especially a raised floor) of unknown capacity.

WARNING

Heavily loaded racks may require reinforced tiles or a structure on a raised floor.

Rack Space

Select a location for the rack that will afford adequate space for the door to open freely, and slide-mounted equipment to be extended.

The rack requires a minimum of 600 mm for rear door clearance.

Equipment Installation Guidelines

Several guidelines should be kept in mind when installing equipment into racks. The two main considerations are weight and balance (for slide-mounted equipment), and heat dissipation. This section includes some worksheets for calculating the weight and balance for slide mounted products and an optional work surface. A discussion of acoustic considerations is also included.

Always install equipment from the bottom to the top to keep the center of gravity as low as possible. The order that you put them should be based on how well a given piece of equipment promotes or impedes heat removal, if heat removal is an issue.

In the event that scratches are incurred during equipment installation, note that touch up paint is available in a spray can via part number 6010-1522C.

Cooling

Instrument racking influences airflow in two significant ways: the proximity to the rear of the rack, and placement of the highest heat-producing pieces of equipment. Equipment protruding the closest to the back should be placed lower, to prevent them from trapping heat and creating eddy currents as shown in Figure 9.

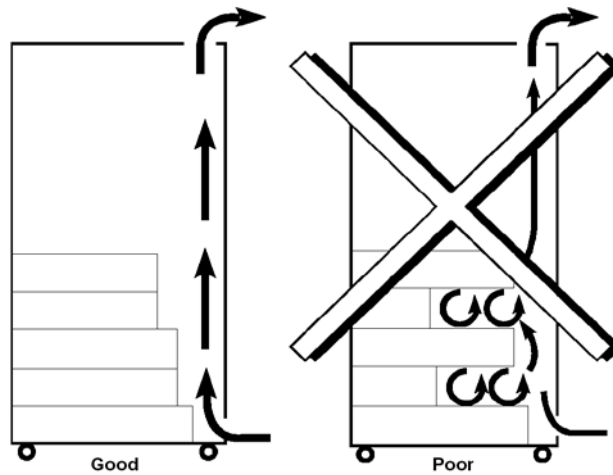

Figure 9 Good and Bad Examples of Equipment Racking Vs Cooling

Components generating the most heat should be placed closest to the top to avoid heating the equipment above it as the generated heat rises in the convection current. Figure 10 shows projected temperature with and without the extractor fan.

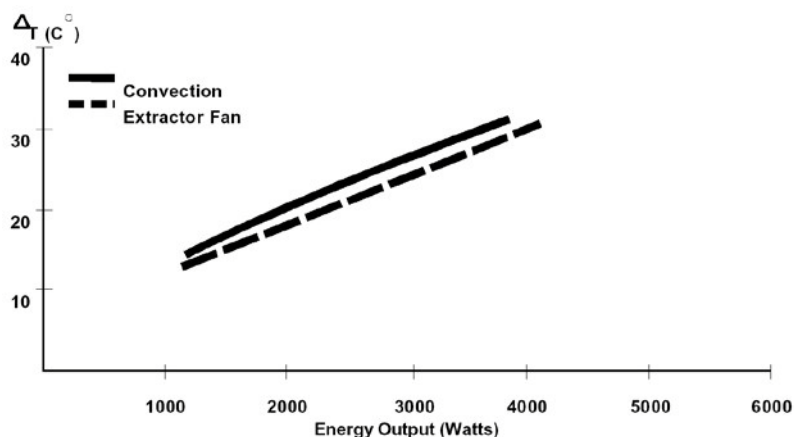

Figure 10 Projected Temperature Vs Energy Output

To ensure adequate cooling in systems using an extractor fan assembly, all unused front panel space must be covered with blank filler panels and the rear door must be closed.

Weight and Balance

Slide-mounted products and work surface/keyboard products need weight and balance calculations performed to determine the need for ballast to reduce the risk of cabinet instability. The worksheets for both are provided on the following pages. If both slide-mounted and work surface/keyboard products are being used, calculate both and add the results.

Slide-Mounted Products

To reduce the risk of rack instability when operator serviceable, slide-mounted products are installed, use the following worksheet to determine the need for additional counterweight ballast. If there are no operator serviceable, slide-mounted products in the rack, this worksheet can be ignored.

An operator serviceable, slide mounted product is defined as any product which can be extended from the rack for servicing without requiring the use of any tool. A product requiring the use of a tool to facilitate servicing or extending the product is the definition of trained service personnel serviceable only. When a trained service personnel serviceable only product is extended, the use of the rack stabilizer assembly is required, but counterweight ballast is not. See Figure 11.

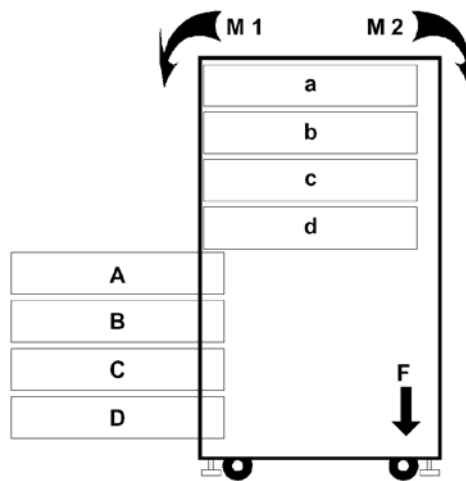

Figure 11 Moment Illustration for Slide Mounted Products

Weight and balance worksheet:

- 1 Total the weight of operator serviceable slide-mounted products: A=_ lbs; B= lbs; C=lbs; D=lbs; . . .
- 2 Total the weight of all fixed and trained service personnel serviceable products:

a=lbs; b=lbs; c=lbs; d=lbs; . . .

- 3 Calculate the moment for both the operator serviceable slide-mounted products (M1) and the fixed and trained service personnel serviceable products (M2) totals from above:

$$M1 = (A + B + C + D + . . .) * 1.25 \text{ ft} = \text{ft/lbs}$$

$$M2 = 16.1 \text{ ft/lbs} + (a + b + c + d + . . .) * 1.00 \text{ ft} = \text{ft/lbs}$$

If M1 is less than or equal to M2, no additional counter weight is needed.

If M1 is greater than M2, use the formulas below to determine the required counter weight.

- 4 Determine required counter weight if M1 is greater than M2:

$$\text{Force (in lbs)} = M1 - M2 \text{ ft/lbs (2.05 ft = amount of force @ 2.05 ft)}$$

Each ballast kit weighs 30 lbs

Work Surface/Keyboard

To reduce the risk of rack instability when using a work surface as illustrated in Figure 12, use the following worksheet to determine the need for additional counterweight ballast. If there are no work surfaces or keyboard mounting kits in the rack, this worksheet can be ignored.

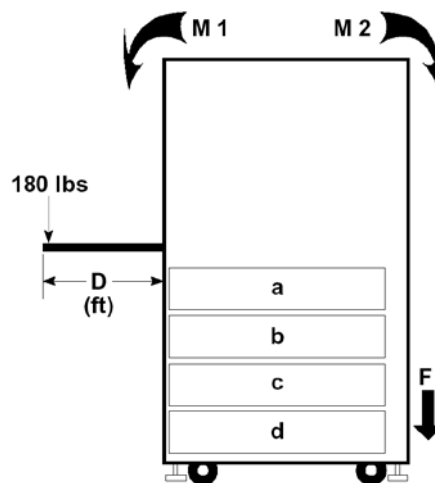

Figure 12 Moment Illustration for Work Surface

Weight and Balance Worksheet:

1. Total the weight of the keyboard/work surface product: D=ft
2. Total the weight of all fixed and trained service personnel serviceable slide-mounted products:
a=lbs; b=lbs; c=lbs; d=lbs; . . .
3. Calculate the moment for both the (M1) and the fixed and trained service personnel serviceable slide-mounted products (M2) totals from above:

$M1 = 180 \text{ lbs} * D \text{ ft} = _ \text{ft/lbs} = \text{moment of rack with 180 lbs of force applied at D feet}$

$M2 = 254.00 \text{ ft/lbs} + (a + b + c + d + . . .) * 1.00 \text{ ft} = \text{ft/lbs}$

If M1 is less than or equal to M2, no additional counter weight is needed.

If M1 is greater than M2, use the formulas below to determine the required counter weight.

4. Determine required counter weight if M1 is greater than M2:

Force (in lbs) = $M1 - M2 \text{ ft/lbs} (2.05 \text{ ft} = \text{amount of force @ } 2.05 \text{ ft})$
 Force (in lbs) = $M1 - M2 \text{ ft/lbs} (\text{Height of drawer at its center.})$

CAUTION

The anti-tip stabilizer is not a substitute for ballast. Use the anti-tip mechanism when loading or unloading equipment.

The first consideration, after leveling the rack on the leveling feet, and extending the anti-tip mechanism, is to load the rack from the bottom to the top.

Acoustic Considerations

Airborne audible noise is a primary concern for most system configurations. Noise from forced convection thermal management solutions such as the extractor fan is directly proportional to the volume of air passing through the rack.

Total system noise should be considered during the design phase, as it can affect areas where the system can be used, operator comfort and safety, and impact federal and regulatory agency compliance requirements for noise output.

Individual product noise can augment (increase) system noise above extractor fan ratings due to constructive (additive) interference between various in-place frequencies, and decrease below the extractor ratings if destructive (subtractive) interference is present.

Total system noise is impossible to calculate completely accurately. Therefore, system acoustic performance should be measured to ensure that acoustic goals are met. However, assuming the worst case (constructive) noise levels, some general estimating guidelines can be used to combine noise levels of system products used together. Acoustic sound power and pressure data are logarithmic (not linear). Thus:

$$50 \text{ dB} + 44 \text{ dB} = 51 \text{ dB}$$

Below are two examples to illustrate the point.

Example 1. What is the estimated sound power output of my two-component system if component 1 contributes 50 dB, and component 2 contributes 65 dB? Original equation with variable x.

$$50 \text{ dB} + 65 \text{ dB} = x \text{ dB}$$

Divide the entire equation by 10. $50/10 \text{ dB} + 65/10 \text{ dB} = x/10 \text{ dB}$

Write the equation in powers of 10 (dB units are Log base 10 units). $10^5 + 10^{6.5} = 10^{x/10}$

Evaluate the left side of the equation. $100,000 + 3,162,277.66 = 10^{x/10}$

$$3,262,277.6 = 10^{x/10}$$

Take the log of both sides of the equation (return to dB units). $\log(3,262,277.66)$
 $\text{dB} = x/10 \text{ dB}$

6.51 dB = $x/10$ dB Now solve for x:

$$x = 65.1 \text{ dB}$$

Thus, adding 50 dB to 65 dB results in a 0.1 dB increase in noise.

Example 2. What is the maximum estimated noise level of a product I want to install if the system is currently rated at 65 dB and my limit is 70 dB?

Original equation with variable x. $x \text{ dB} = 70 \text{ dB} - 65 \text{ dB}$

Divide by 10.

$$x/10 \text{ dB} = 70/10 \text{ dB} - 65/10 \text{ dB} \quad x/10 \text{ dB} = 7.0 \text{ dB} - 6.5 \text{ dB}$$

$$x/10 \text{ dB} = 0.5 \text{ dB}$$

Write the equation in powers of 10 (dB units are Log base 10 units). $10_{x/10} = 10_{0.5}$

Take the log of both sides of the equation (return to dB units). $x/10 \text{ dB} = \log(0.5)$
 $= 6.837 \text{ dB}$

Solve for x. $x = 68.37 \text{ dB}$

More than double the noise is required to increase the total noise from 65 dB to 70 dB.

Estimating Total Noise

For a quick estimate of total noise from two sources, see Figure 13 if the two dB levels are within 16 dB of each other. If the difference is greater than 16 dB, the effect of the lower noise level is negligible (zero for calculations).

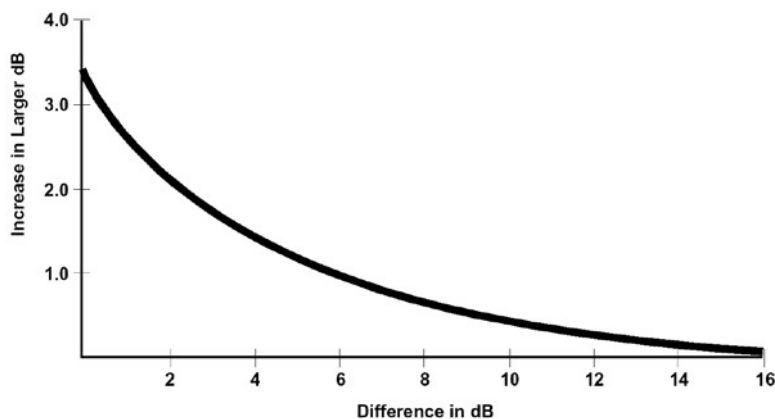

Figure 13 Estimating System Noise

For example, the combination of a 50 dB noise and a 54 dB noise has a difference of 4 dB. Using Figure 13, 4 dB difference results in adding 1.4 dB to the higher noise, resulting in an estimated 55.4 dB total noise.

Procedures

This chapter describes unpacking and repackaging the Keysight rack for shipment, and common procedures such as positioning racks, removal and replacement procedures.

Receiving

This section contains information pertaining to unpacking, inspection, and reshipment.

Make sure that all doors, elevators, and passageways in route to the site are large enough to accommodate the rack.

The packaged physical specifications for the racks are listed below.

Rack	Height	Width	Depth	Weight
E7590A	1.52 m / 60 in	.76 m/ 30 in	1.7 m / 67 in	140.6 kg/310 lbs
E3661B	1.8 m / 72 in	.76 m/ 30 in	1.7 m / 67 in	161 kg/355 lbs
E3662B	2.2 m / 87.5 in	.76 m/ 30 in	1.7 m / 67 in	177 kg/390 lbs

Floor elevators and lifting equipment must be of sufficient capacity.

If the rack package is damaged upon receipt, request that the carrier's agent be present when the protective covering is removed. Inspect the rack for damage (scratches, dents, bent pieces, etc.). If the rack is damaged notify the carrier and the nearest Keysight Technologies Sales and Service office immediately.

CAUTION

Do not lift an unpackaged rack with a fork lift.

Unpacking and Handling

The lifting brackets supplied with the rack are suitable for lifting the rack when fully loaded.

Use the following procedure to remove the rack from the shipping base. One person can perform this procedure.

- 1 Cut the poly strap bands around the shipping container. See Figure 14.

WARNING

Wear protective glasses while cutting the plastic bands around the shipping container. These bands are under tension. When cut, they can spring back and cause serious eye injury.

- 2 Lift the cardboard top cap from the shipping box.
- 3 Remove the corrugated wrap from the pallet.
- 4 Remove the packing materials.

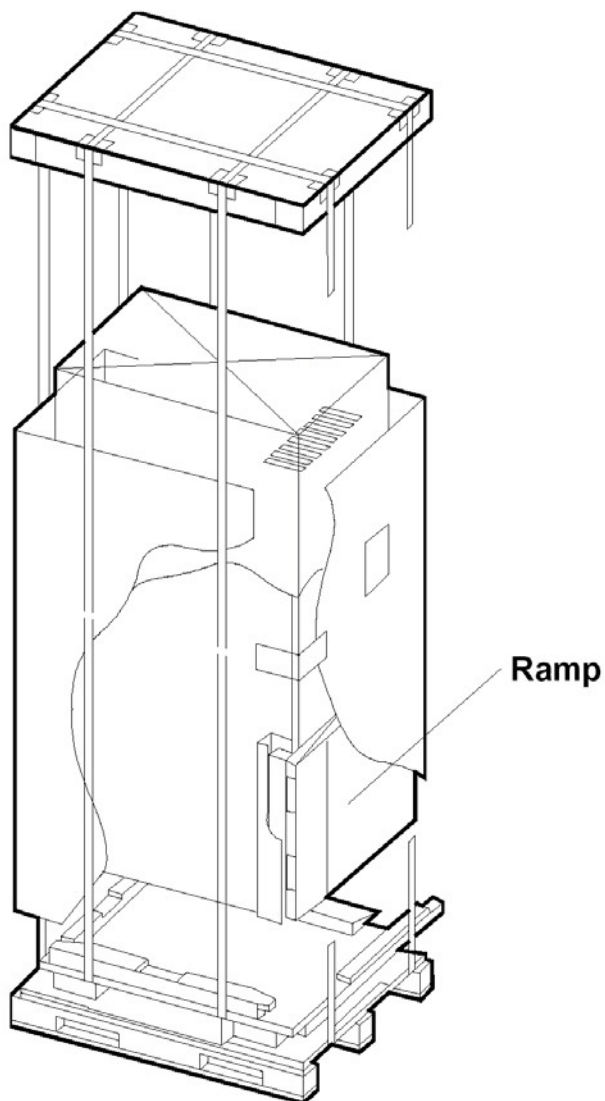

Figure 14 Lifting the Packing Lid Off

- 5 Remove the folded ramp from the side of the rack.
- 6 Remove the two bolts (1) holding the anti-roll block in place at the bottom-rear (see Figures 15). Remove the block.

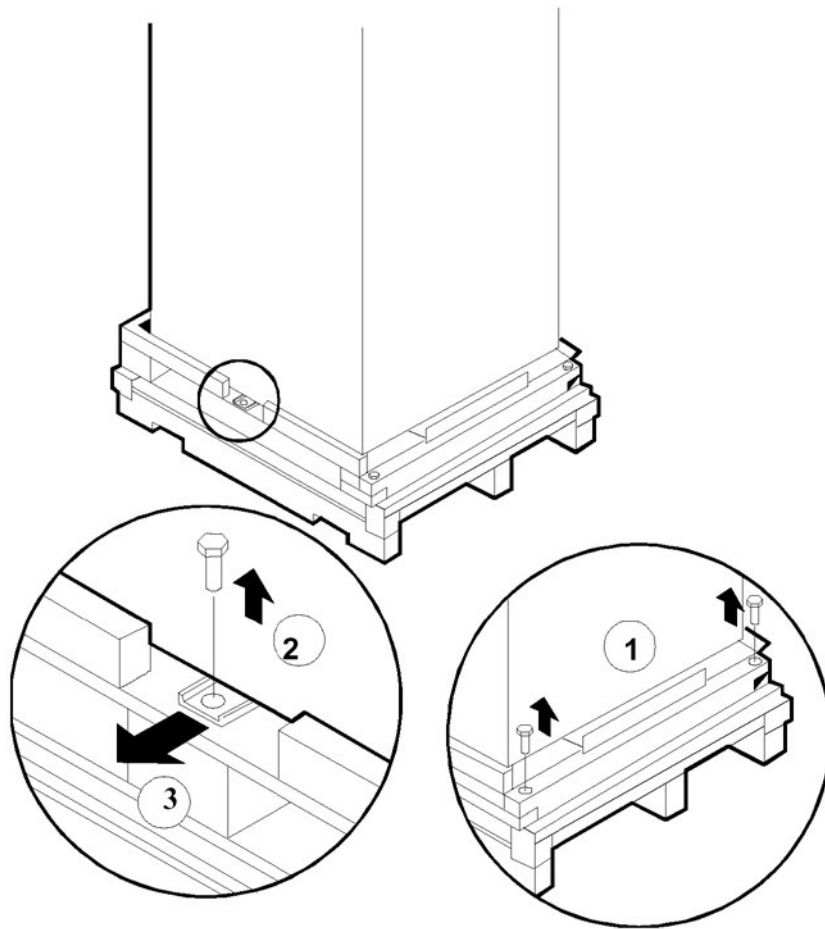

Figure 15 Unclamping

- 7** Remove the bolts (2), one on each side, from the shipping clamp at the bottom of the frame. They are bolted to the pallet.
- 8** Remove the clamp (3).
- 9** Unfold and position the ramp so that the block of wood under the ramp locks into the edge of the pallet, with the strip of wood forming a lip. This holds the ramp in place while the rack is moved across the pallet and down the ramp. See Figure 16.

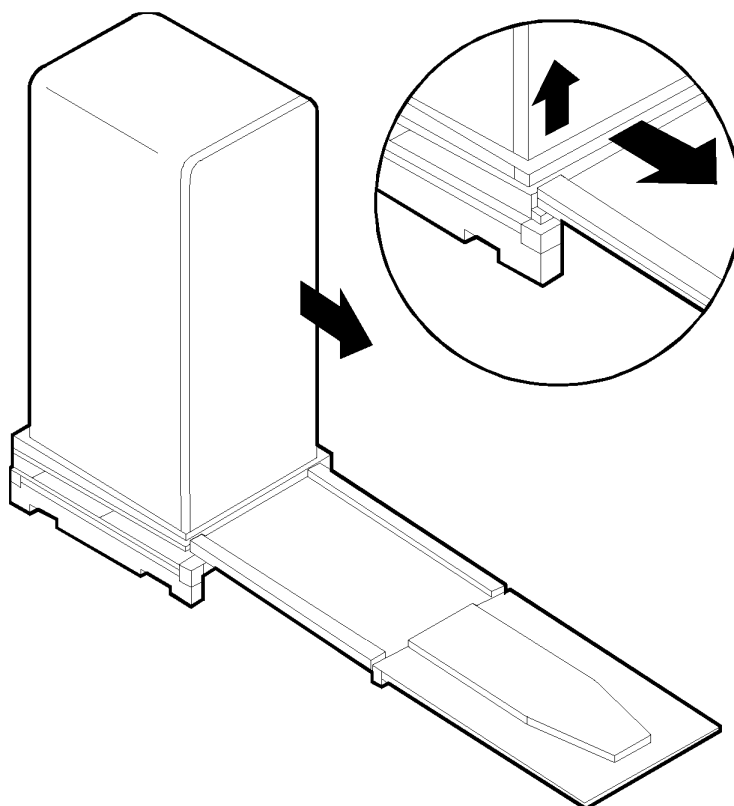

Figure 16 Positioning the Ramp

10 Raise the leveling feet all the way up before moving the rack.

WARNING

Make sure that the leveling feet on the rack are raised before you roll the rack down the ramp, and any time you roll the rack on the casters.

Repackaging the Rack for Shipment

Use the original packing material to repack the empty rack for shipment.

Before shipment, securely place a tag on the container (and equipment) to identify the owner and the service to be performed. Include the rack model number.

To repack the rack, follow the repackaging checklist below, and refer to the unpacking instructions for details.

- 1** Assemble the original Keysight packing materials.
- 2** Connect the loading ramp to the pallet.

- 3** Raise the leveling feet.
- 4** Push the rack up the ramp, front first.
- 5** Secure the rack to the pallet with the shipping clamps, shipping block, and rear door support.
- 6** Place the anti-static bag over the rack.
- 7** Place the top cap packing material and loading/unloading ramp on top of the rack.
- 8** Place the corrugated wrap around the rack.
- 9** Put the box top on the box.
- 10** Secure the top to the pallet with top-to-bottom plastic bands.

Removal and Replacement

This section provides removal and replacement procedures for the standard assembly.

Rear Door Removal

- 1** Open rear door.
- 2** Disconnect the bonding wire from the door.
- 3** Grasp the rear door support and lift the door straight up and away from the cabinet.

Rear Door Replacement

- 1** Hold the rear door by the support column.
- 2** Align the door hinge pins over the rack hinge holes.
- 3** Lower the door onto the rack hinge.
- 4** Reconnect the door onto the rack hinge.

Top Cap Removal

- 1** Open the rear door all the way.
- 2** Remove the two outside mounting screws at the top-rear of the rack.
- 3** From the rear of the rack, pull the top cap toward the back a few inches.
- 4** Lift the top cap from the rack.

Top Cap Replacement

- 1** Open the rear door all the way.
- 2** From the rear of the rack, place the top cap between the side covers and slide it forward until it stops.

- 3 Insert and tighten the two mounting screws at the top-rear.
- 4 Close the rear door.

Side Cover Removal

- 1 Remove the two mounting screws at the bottom of the rack.
- 2 On the right-side cover, open the rear door and remove the two mounting screws on the upper door hinge (that secure the hinge to the side panel).
- 3 Grasp the sides of the side cover and pull it up and away from the rack.

Side Cover Replacement

- 1 Grasp the sides of the side cover and align it with the rack at a vertical angle with the bottom out and the top toward the top of the rack.
- 2 Hook the top of the side cover over the top of the rack.
- 3 With the side cover up flush against the frame, replace the two mounting screws at the bottom of the rack.
- 4 On the right-side cover, insert and tighten the two mounting screws on the upper door hinge (that secure the hinge to the side panel).

Forehead Assembly Removal

- 1 Turn the power OFF. Disconnect AC power to the rack.
- 2 Remove top cap assembly (refer to top cap removal).
- 3 Unplug the PDU harness(es) from the back of the main power switch (if present).
- 4 Remove the three mounting screws behind the forehead assembly.
- 5 Lift the forehead assembly up and away from the rack frame.

Forehead Assembly Replacement

- 1 Align the forehead assembly at the top of the rack frame, so the three mounting holes match the frame holes, and the mounting hooks on each side engage the mounting slots.
- 2 Insert the three mounting screws through the frame into the forehead assembly.
- 3 If appropriate, attach the PDU harness(es) to the main power switch terminals. Slip-on connectors mate with spade terminals on the back of the switch. Ensure each connector is fastened.

CAUTION

Connections from the PDU front panel switch harness and the switch in the forehead must be made correctly to ensure normal PDU operation. Failure to do so can result in PDU failure or inconsistent PDU operation.

- 4 Replace the top cap (refer to top cap replacement).
- 5 If appropriate, connect AC power to the cabinet.
- 6 Turn the main power switch ON.

Base Cover Removal

- 1 Remove the mounting screw located on the top edge, center, of the base cover.
- 2 Pull the base cover away from the bottom of the rack.

Base Cover Replacement

- 1 Align the base cover at the bottom of the rack and roll the base cover until the mounting holes in the rack and base cover align.
- 2 Insert and tighten the mounting screw.

Anti-tip Stabilizer Removal

- 1 Extend the anti-tip stabilizer until it stops.
- 2 Lift the two sidebars that go into the rack frame, and pull the stabilizer away from the rack.

Anti-tip Stabilizer Replacement

- 1 Align the two extension arms with the opening at the bottom of the rack, and insert the arms at an angle. This allows the stop tabs to go into the rack cavity for the stabilizer.
- 2 Push the anti-tip stabilizer all the way into the rack.

Rear Door Hinge Removal

- 1 Remove the rear door (refer to Rear Door Removal).
- 2 Remove the two mounting screws from the rack column (on the upper hinge, also remove the two mounting screws in the side panel), and lift the door hinge away.

Rear Door Hinge Replacement

- 1 Align the door hinge with the pressed nuts in the rear rack column.
- 2 Insert and tighten the two mounting screws through the hinge into the column (on the upper hinge, also insert the two mounting screws into the side panel).

Rail Removal

This procedure is also used to remove a rail clamp.

- 1 Remove the component mounted on the rail being removed.

NOTE

Be sure to tag the cables disconnected for easy reconnection.

- 2 Remove the two rail mounting screws.
- 3 Lift the rail out of its notches in the support columns.
- 4 To remove the rail clamp, remove the clamp screw and slide the clamp out of the rail groove.

Rail Replacement

- 1 Slide the rail clamp onto the rail.
- 2 Insert the rail tabs into the appropriate support column notches.
- 3 Insert and tighten the two mounting screws through the rail into the clip nuts on the column.
- 4 Reinstall the component.
- 5 Slide the rail clamp up to the rear of the component and insert the clamp screw.

Leveler or Caster Removal

- 1 Turn the rack power switch OFF.
- 2 Disconnect AC power to the rack.
- 3 Carefully move the rack to an area with enough room to allow the rack to be laid on its side.
- 4 Remove all equipment components from the rack.
- 5 Carefully lay the rack on its side.
- 6 Unscrew the leveler, or remove the castor by removing the four mounting nuts and pulling the castor off.

Leveler or Caster Replacement

- 1 With the rack on its side, screw in the leveler, or place the castor over the four mounting studs and attach with the four mounting nuts.
- 2 Carefully lift the rack to the upright position.
- 3 Install all equipment components.
- 4 Return the rack to its install site.
- 5 Reconnect AC power.

Ballast Removal

Remove the two screws holding the ballast on the rear rack columns. Use caution not to drop the ballast when removing these screws.

CAUTION

The ballast weighs 30 lbs and can damage equipment or cause personal injury if dropped.

Ballast Replacement

Attach the ballast to the rear columns using the two screws. Ballast should be installed at the bottom of the rack, resting adjacent to the rear base. If ballast cannot be installed at the base of the rack, it can be installed using the rack shelf.

Install additional ballast adjacent to each other so that they provide support for each other.

NOTE

If ballast cannot be installed at the bottom of the rack, it can be installed using the plain rack shelf. The plain rack shelf can support up to four ballast (120 lbs) units. Remove ballast before moving or shipping a rack.

Door Bumper

The rear and front door bumpers are self-adhesive rubber bumpers stuck to the door. Remove by prying off with a flat bladed screwdriver. Apply by peeling off the adhesive cover and pressing into place.



This information is subject to change
without notice
© Keysight Technologies 2015
Edition 3 August 2015
Published in USA



5967-9318

www.keysight.com