

PFK9-series

High precision weighing platforms

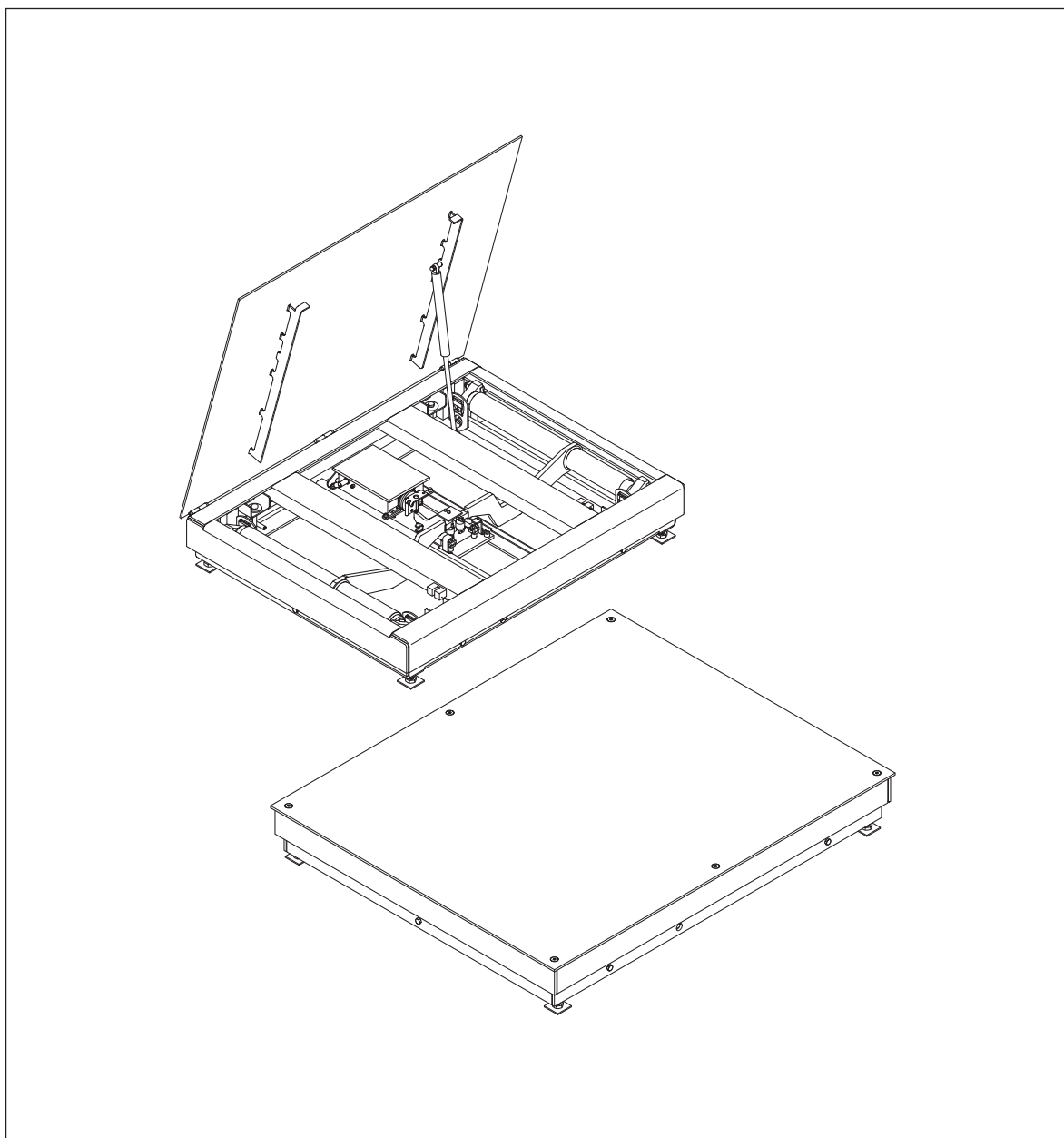

METTLER TOLEDO

METTLER TOLEDO Service

Congratulations on choosing the quality and precision of METTLER TOLEDO. Proper use of your new equipment according to this User manual and regular calibration and maintenance by our factory-trained service team ensures dependable and accurate operation, protecting your investment. Contact us about a service agreement tailored to your needs and budget. Further information is available at www.mt.com/service.

There are several important ways to ensure you maximize the performance of your investment:

1. **Register your product:** We invite you to register your product at www.mt.com/productregistration so we can contact you about enhancements, updates and important notifications concerning your product.
2. **Contact METTLER TOLEDO for service:** The value of a measurement is proportional to its accuracy – an out of specification scale can diminish quality, reduce profits and increase liability. Timely service from METTLER TOLEDO will ensure accuracy and optimize uptime and equipment life.
 - **Installation, Configuration, Integration and Training:**
Our service representatives are factory-trained, weighing equipment experts. We make certain that your weighing equipment is ready for production in a cost effective and timely fashion and that personnel are trained for success.
 - **Initial Calibration Documentation:**
The installation environment and application requirements are unique for every industrial scale so performance must be tested and certified. Our calibration services and certificates document accuracy to ensure production quality and provide a quality system record of performance.
 - **Periodic Calibration Maintenance:**
A Calibration Service Agreement provides on-going confidence in your weighing process and documentation of compliance with requirements. We offer a variety of service plans that are scheduled to meet your needs and designed to fit your budget.

Contents

1	Safety information for operation in the Ex area	4
2	Installation.....	6
2.1	Preparatory work	6
2.2	Setting up	7
2.3	Levelling	12
2.4	Pit installation.....	13
2.5	Lengthening and installing connection cable.....	13
2.6	Equipotential bonding in hazardous areas	14
2.7	Connecting PFK98_APW weighing platforms	15
2.8	Commissioning	17
3	Configuration possibilities	18
3.1	General information.....	18
3.2	Configuration data in the factory setting	19
4	Planning assemblies.....	20
4.1	Notes on planning.....	20
4.2	Preload range.....	20
4.3	Mounting possibilities.....	21
4.4	Opening possibilities	25
5	Dimensions	29

1 Safety information for operation in the Ex area



- ▲ The PFK9-series high precision weighing platforms are approved for operation in Zone 2 (gases), Zone 22 (dusts) and DIV 2 hazardous areas. There is an increased risk in injury and damage when using the explosion-protected weighing platforms in a potentially explosive atmosphere. Special care must be taken when working in such hazardous areas.
 - ▲ Any protective foils present in the hazardous area, e.g. on the load plate, must always be removed.
- Competence**
- ▲ In hazardous areas, the weighing platforms may only be installed, maintained and repaired by authorized METTLER TOLEDO service personnel.
- Ex approval**
- ▲ No modifications may be made to the weighing platform and no repair work may be performed on the system modules. Any weighing platform or system modules that are used must comply with the specifications contained in the installation instructions. Non-compliant equipment jeopardizes the intrinsic safety of the system, cancels the "Ex" approval and renders any warranty or product liability claims null and void.
 - ▲ The safety of the weighing system is only guaranteed when the weighing system is operated, installed and maintained in accordance with the respective instructions.
 - ▲ Also comply with the following:
 - the instructions for the system modules,
 - the regulations and standards in the respective country,
 - the statutory requirement for electrical equipment installed in hazardous areas in the respective country,
 - all instructions related to safety issued by the owner.
 - ▲ The explosion-protected weighing system must be checked to ensure compliance with the requirements for safety before being put into service for the first time, following any service work and every 3 years, at least.
- Operation**
- ▲ Prevent the build-up of static electricity. Always wear suitable working clothes when operating or performing service work in a hazardous area. Avoid strong mechanical rubbing of the powder-coated surfaces against any material when operating in Zone 22.
 - ▲ Do not use protective coverings for the devices.
 - ▲ Avoid damage to the system components.
 - ▲ If system damage occurs, the system must be put out of operation immediately.
 - ▲ Damaged system components must be replaced immediately.

- Installation**
- ▲ Only install or perform maintenance work on the weighing system in hazardous areas if the following conditions are fulfilled:
 - the intrinsically safe characteristic values and zone approval of the individual components are in accord with one another,
 - the owner has issued a permit ("spark permit" or "fire permit"),
 - the area has been rendered safe and the owner's safety coordinator has confirmed that there is no danger,
 - the necessary tools and any required protective clothing are provided (danger of the build-up of static electricity).
 - ▲ The certification papers (certificates, manufacturer's declarations) must be present.
 - ▲ Lay cabling fixed and securely, bending radius > 5 x cable diameter.
 - ▲ Do not cut through cables.

Additional requirements for Zones 2/22 or DIV 2

- ▲ The explosion protected PFK9-series high precision weighing platforms may only be operated in hazardous areas of Zone 2 (gases), Zone 22 (dusts) and DIV 2 in conjunction with weighing terminals that have the appropriate approval and interface specification.
- ▲ The connection cable may not be separated from the weighing terminal while it is energized.
- ▲ Tighten the knurled nut of the M12 connection cable with a tightening torque of 10 Nm.
- ▲ Before setting up the system secure the connection between weighing terminal and weighing platform.

2 Installation

2.1 Preparatory work

2.1.1 Selecting installation location

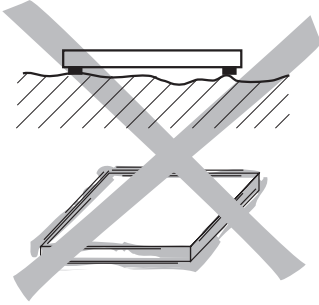

- ▲ The foundation at the installation location must be capable to safely support the weight of the weighing platform at its support points when it carries the maximum load. At the same time, it should be so stable that no vibrations occur during weighing operations. These requirements also apply when the weighing platform is integrated in conveying systems and the like.
- ▲ Ensure that the ground at the installation location is even.
- ▲ Ensure that there are no vibrations from machines near the installation site.
- ▲ Ensure that there are no drafts at the installation site.

2.1.2 Ambient conditions

- Use powder-coated/hot galvanized weighing platforms only in a dry environment.
- In a damp environment, in wet operation or when working with chemicals: Use stainless-steel weighing platforms.

2.1.3 Accessories

- Completely unpack the accessories provided with the weighing platform.
 - 1 bottle of oil, suitable for foodstuffs
 - 1 set of measuring data signs for selectable configurations
 - Optional: ACC409xx-SICSpro-IDNet converter (incl. identcard kit) additionally provided for sizes D, E, ES:
 - 4 eye bolts in a bag
 - 2 eye bolts in a bag additionally provided for weighing platforms with foldable load plate:
 - 1 handle

2.2 Setting up

2.2.1 Size C

Setting up



CAUTION

Danger of injury due to the heavy load plate.

- ▲ Always ask a second person to help removing the load plate.
- ▲ Wear gloves when removing the load plate.

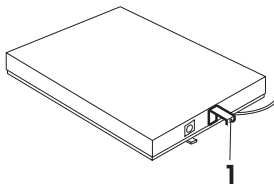

1. Remove the load plate by pivoting the two side handles (1) outward.
2. Lift the weighing platform off the transport pallet and set it down at the installation location.

Be careful when lifting it off the pallet to prevent the lever mechanism which is open at the bottom from being damaged.

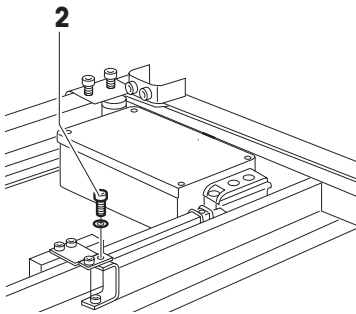

3. Unscrew and remove the yellow locking screw (3).
4. Loosen the lever lock and remove the transport lock.

Note

Keep the locking elements for use for transporting the weighing platform in the future.

Routing the connection cable

The connection cable is stored inside the weighing platform during transport for protection.

1. Route out the connection cable under the base frame.
2. Replace the load plate (3) so that the symbol ● is located above the level indicator.
3. Make sure that the load supports (4) in the corners of the weighing platform are vertical.

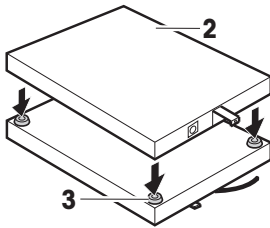

2.2.2 Sizes D / E / ES

Setting up



CAUTION

Danger of injury due to the heavy load plate.

- ▲ Always move the weighing platforms with the aid of a second person or with an appropriate tool.
- ▲ Wear gloves.

NOTICE

Damage to the lever mechanism when using forklift trucks because the lever mechanism is open at the bottom.

- ▲ Move up the load forks of the forklift truck and hang the weighing platform on them as described.

Setting up weighing platforms with fixed load plate

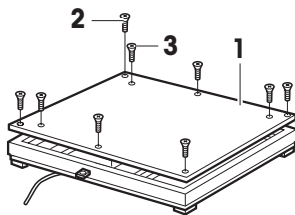

1. Lift off the load plate (1) after unscrewing the 6 or 8 screws (2). The eye bolts (3) can be screwed into the threads after removing the blind screws as lifting aid. Depending on the shipping warehouse or the model ordered, the load plate may also be included in separate packing. Then the mounting screws and the blindscrews are supplied in the accessories bag.

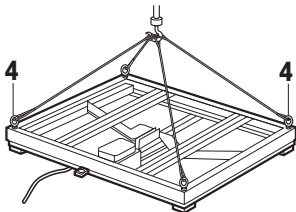

2. Lift the weighing platform off the transport pallet. To do this, screw the four eyebolts (4) provided into the threads at the corners of the load plate mounting device and lift off the weighing platform with a crane, block and tackle or similar equipment and set it down at the installation location.

Setting up weighing platforms with foldable load plate

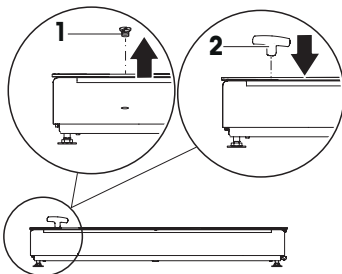

1. Use a screwdriver to screw out the cover screw (1).
2. Turn the handle (2) clockwise into the exposed thread until it stops.

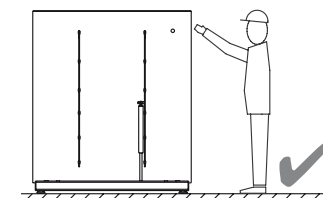

3. Position yourself on the right-hand side next to the weighing platform.

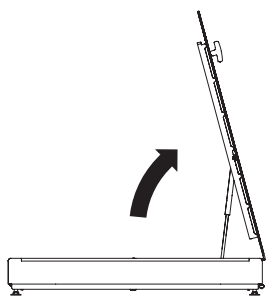

- Pull the load plate up using the handle.



DANGER

Danger of injury due to shutting load plate.

- ▲ Ensure that the pneumatic spring has extended completely.

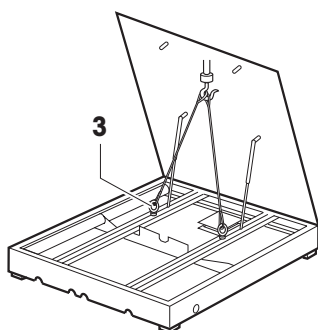

- Lift the weighing platform off the transport pallet. To do this, screw the two eyebolts (3) provided (they are located on the inside on the level indicator side) into the threads of the load frame and lift off the weighing platform with a crane, block and tackle or similar equipment and set it down at the installation location.
- Remove the eye bolts.

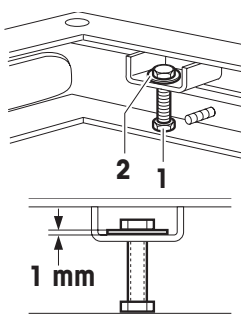

Releasing lift-off locks and removing transportation locks

- Loosen the nuts (1) at all 4 corners.
- Screw up the locking screws (2) and adjust evenly to approx. 1 mm clearance at all 4 corners.
- Retighten the nuts (1).

4. Remove the lever lock (3) by unscrewing 2 screws.
5. Remove the transportation lock (4).

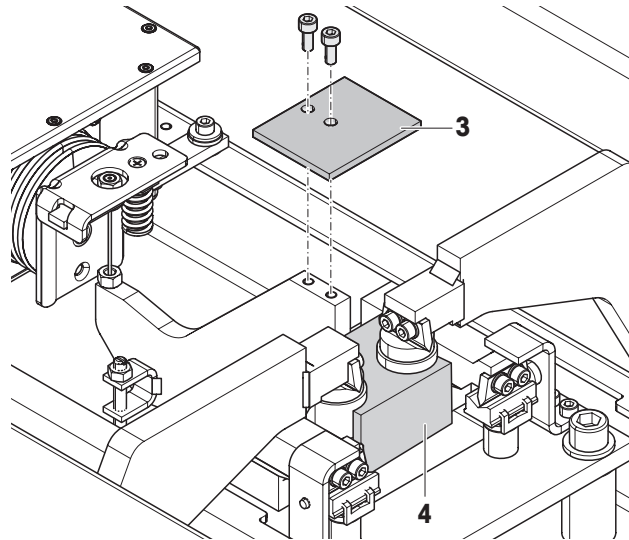

6. Mount the lever lock (3) with 2 screws.

Routing the connection cable

The connection cable (1) is stored inside the weighing platform during transport for protection. Depending on the conditions at the installation location, the connection cable can be routed out as follows:

- Below the weighing platform on the floor
Ideal with the recessing installation of the weighing platform. In the case of above-floor installation protective cable bridges can be laid up to under the weighing platform.
- Through the base frame

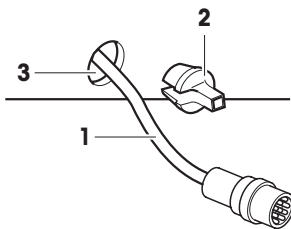

1. Remove the rubber grommet (2) from the hole (3) in the base frame and pull through the connection cable (1).
2. Push the slotted rubber grommet (2) over the cable and insert it in the hole (3).

Closing weighing platforms with fixed load plate

1. Put on the load plate (4) and mount it with the screws (5) (quick-release locks).
2. Screw the blind screws into the threads.

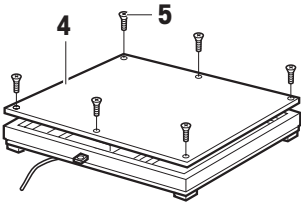

Closing weighing platforms with foldable load plate

1. Position yourself on the right-hand side next to the weighing platform.

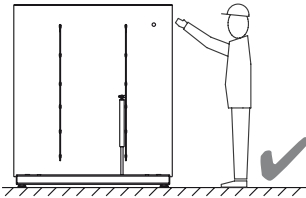

2. Press the load plate down using the handle.

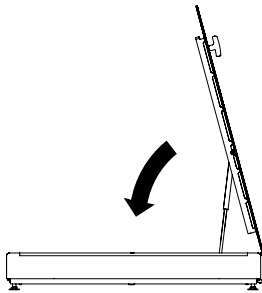

3. Ensure that the load plate latches in and lies evenly on the load frame.
4. Turn out the handle (1) counter-clockwise.
5. Screw the cover screw (2) into the load plate.

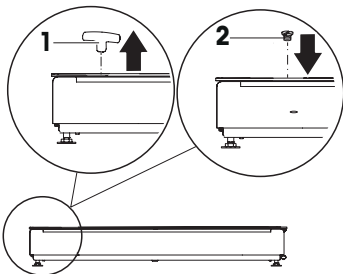

2.3 Levelling

Notes

- Only weighing platforms that have been levelled precisely horizontally provide accurate weighing results.
- Redo levelling when the weighing platform has been moved.

2.3.1 Size C

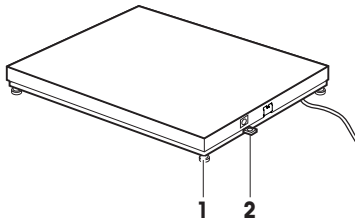

1. Level the weighing platform with the 4 foot bolts (1) using the level indicator (2): The air bubble of the level indicator must come to rest within the ring marking.
 - With recessed weighing platforms lift off the load plate.
 - Use a spanner to adjust the height of the foot bolts.
2. Ensure even contact of the foot bolts. Every foot must stand safely and must have full contact with its entire surface. Check the stability of the weighing platform by pressing down on or rocking it at the corners.
3. With recessed weighing platforms put on the load plate.

2.3.2 Sizes D / E / ES

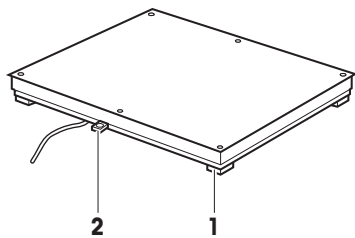

1. Level the weighing platform with the 4 foot bolts (1) using the level indicator (2): The air bubble of the level indicator must come to rest within the ring marking.
 - Lift off or open the load plate.
 - Use a screwdriver to adjust the height of the foot bolts underneath the holes (3).
2. Ensure even contact of the foot bolts. Every foot must stand safely and must have full contact with its entire surface. Check the stability of the weighing platform by pressing down on or rocking it at the corners.

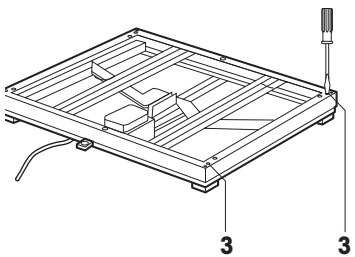

3. Check the over all height.
 - Put a ruler diagonally over corners I and III and check levelness with a water level.
 - Adjust the height of the cornes with a screwdriver until they are even.
 - Repeat this procedure for cornes II and IV.

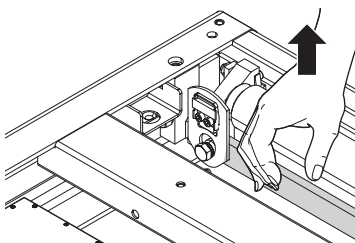
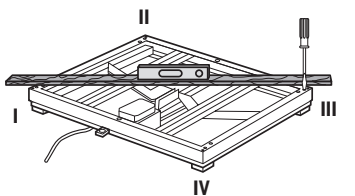

4. Lift up the load frame at all 4 corners manually. The force needed should be approximately the same for all 4 corners.
 - If the force is considerably lower at one corner than at the other corners: Heighten the corresponding corner.
 - If the force is considerably higher at one corner than at the other corners: Lower the corresponding corner.
5. Put on or close the load plate.

2.4 Pit installation

The mounting material and detailed instructions for constructing the pit are included with the "Quick pit for PFK9-series, size C" or "Quick pit for PFK9-series, sizes D / E / ES" installation kit. The proper construction of the pit according to these instructions is a requirement.

2.4.1 Size C

1. Carefully lower the weighing platform into the pit. When doing so, also pull the cable into the empty pipe or cable conduit.
2. Adjust the height of the support feet so that the load plate is flush with the floor.

2.4.2 Sizes D / E / ES

1. Lift off or open the load plate and route out the connection cable under the weighing platform, see Section 2.2.2.
2. Slowly lower the weighing platform into the pit by the eye bolts. When doing so, also pull the cable into the empty pipe or cable conduit.
3. Release the lift-off lock, see Section 2.2.2.
4. Adjust flushness with the floor.

To do this, lay spacers (size D: 6 mm, sizes E / ES: 8 mm) on the load frame at the corners and adjust flush with the upper edge of the pit frame.

Adjust the height of the support feet.

5. To level, see section 2.3.2.
6. Center the weighing platform in the pit with 6 or 8 clamping screws (1) and clamp them firmly in place. Lock the bolts (1) on the inside of the base frame with the nuts (2).
7. Either put on the load plate and screw on firmly or fold down the load plate.

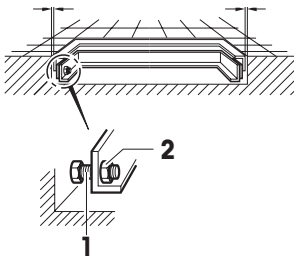
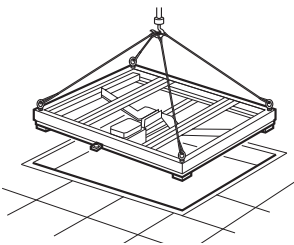

2.5 Lengthening and installing connection cable

The connection cable may be lengthened.

Standard version up to 100 m

Ex version up to 50 m

- Route the connection cable directly out of the weighing platform to the weighing terminal or the ConBloc (PBK98_APW weighing platforms only).

CAUTION

If the cable is laid in a pipe, ensure that the pipe is of a sufficient diameter.

2.6 Equipotential bonding in hazardous areas

The equipotential bonding must be installed by a professional electrician when using the weighing platform in hazardous areas. METTLER TOLEDO Service only has a monitoring and consulting function here.

→ Connect equipotential bonding (PA) of all devices (weighing platform and service terminal) in accordance with the country-specific regulations and standards. In the process, make sure that all device housings are connected to the same potential via the PA terminals.

Location of the equipotential bonding clamp for size C

→ Mount the equipotential bonding clamp on the base frame alongside the load cell.

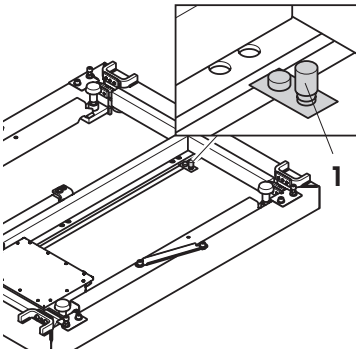

Location of the equipotential bonding clamp for size D / E / ES

→ Mount the equipotential bonding clamp (1) on the base frame.

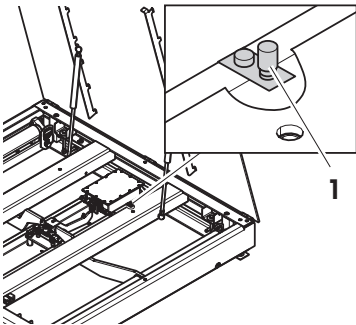

Equipotential bonding clamp

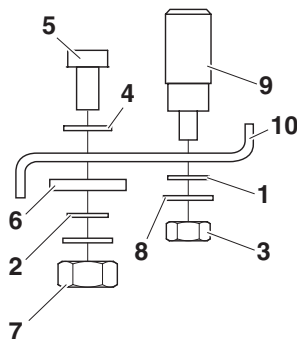

- 1 Serrated lock washer A 4.3 DIN 6798
- 2 Serrated lock washer A 5.3 DIN 6798
- 3 Hexagonal lock nut M4 DIN 934
- 4 Washer 5.3 DIN 125, 2 pcs
- 5 Cheese head screw M5x16 DIN 912
- 6 Base frame
- 7 Hexagonal lock nut M5 DIN 934
- 8 Washer 4.3 DIN 125
- 9 Equipotential bonding clamp
- 10 Equipotential bonding plate

Mounting materials are enclosed with the weighing terminal for hazardous areas, e.g. IND690xx.

2.7 Connecting PFK98_APW weighing platforms

2.7.1 Typical configurations

To connect the PFK98-APW weighing platform to its environment, the ConBlock / ConBlock IP66 is recommended.

Direct connection to the PLC

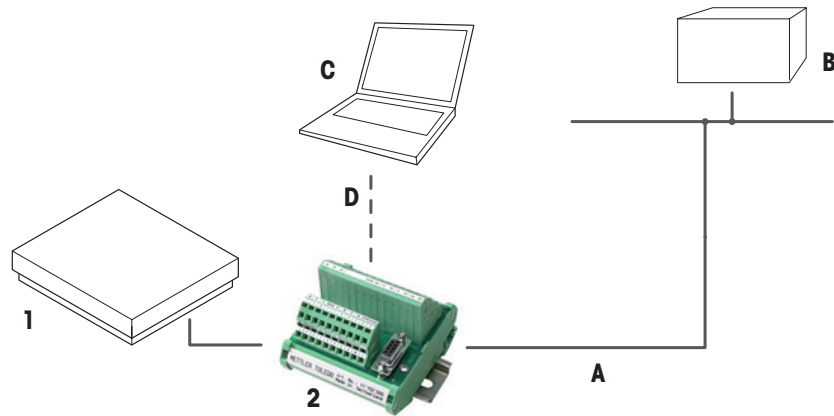

Connection to the PLC via Fieldbus module

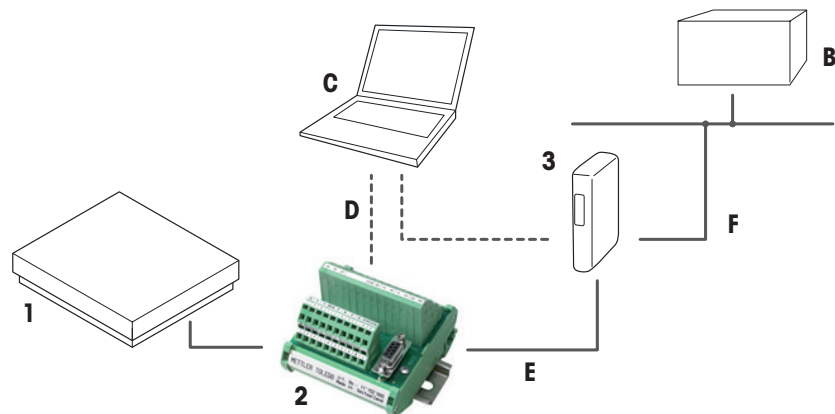

METTLER TOLEDO components

- 1 PFK98_APW weighing platform
- 2 ConModule connection module / ConBlock IP66 connection module with IP66 housing
- 3 Fieldbus module (Profibus, Profinet, DeviceNet, Ethernet/IP, CC-Link)

Customer components

- A Connection cable to PLC, RS232 or RS422/RS485
- B PLC
- C PC or laptop (for configuration and service purpose)
- D Standard RS232 cable (DB9 male/female)
- E Cable, 1 m, D-Sub 9 male <--> open ends
- F Fieldbus cable

2.7.2 Installation with weighing platforms used in hazardous areas



EXPLOSION HAZARD

ConBlock / ConBlock IP66 is not approved for hazardous areas.

- ▲ Only install the ConBlock / ConBlock IP66 in the safe area.
- ▲ Always use a suitable safety barrier to separate equipment located in the hazardous area from the safe area.

2.7.3 ConBlock / ConBlock IP66 connection

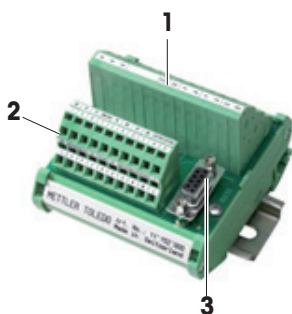

- 1 System connection side: 10 terminals
- 2 Weighing platform connection side: 2 x 10 terminals
- 3 RS232 interface (D-Sub 9), for configuration and servicing

ConBlock connections – weighing platform side

The PFK98_APW weighing platform is delivered with a 12 wire open end cable. The corresponding terminals of the ConBlock are identified by the wire color and the respective pin designation.

Pin	J	D	H	T	F	K	G	E	A	O
Color	–	–	–	–	–	–	–	–	white	brown and green
Signal	–	–	–	–	–	–	–	–	V DC	GND

Pin	L	U	P	C	R	B	S	N	M	Shield
Color	orange	black	purple	violet	blue	red	grey	pink	yellow	braid
Signal	Tx+	Rx+	Tx–	Rx–	CTS	GND INT	RTS	RXD	TXD	Shield

ConBlock connections – system side

The connection terminal strip is grouped according to the following functions: RS232 and RS422/RS485 interface, input voltages and digital inputs and outputs.

RS232		RS422 (in)		RS422 (through)		Power	–	–	–
RXD	RTS	Rx+	Tx+	Rx+	Tx+	V DC	–	–	–
TXD	CTS	Rx–	Tx–	Rx–	Tx–	GND	–	–	–
GND INT	Shield	Shield		Shield		PE	–	–	–

RS422 / RS485 configuration

The RS422 interface is directly available via the connection terminals. For the RS485 configuration, the following signals must be connected:

- A–: Tx– and Rx–
- B+: Tx+ and Rx+

Load cell connector

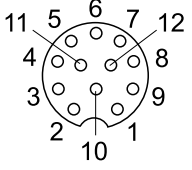
Connector M12	Pin	Load cell signal		Color
	1	V DC in		White
	2	GND in		Brown
	3	GND in		Green
	4	TXD (RS232)		Yellow
	5	RTS (RS232)		Grey
	6	RXD (RS232)		Pink
	7	CTS (RS232)		Blue
	8	GND (RS232)		Red
	9	TX+ (RS422)	B+ (RS485)	Orange
	10	TX- (RS422)	A- (RS485)	Purple
	11	RX+ (RS422)	B+ (RS485)	Black
	12	RX- (RS422)	A- (RS485)	Violet
	Shield			Braid

2.8 Commissioning

2.8.1 Switching on

→ Switch on the weighing system at the final location only.

When switching on the weighing system for the first time, it will perform an automatic geo code adjustment using the calibration weight which is integrated in the load cell.

2.8.2 PBK9APW-series adjustment

In order to reach maximum precision, the weighing platforms of the PBK9APW-series must be adjusted according to the following sequence:

1. Perform an internal adjustment using SICS command C9.
2. For a user specific adjustment use the following SICS commands: C1, C2, C6, C8.

Note

This sequence is automatically performed if you do adjustment with the "Test & Adjustment" menu of the "APW-Link" software.

3 Configuration possibilities

3.1 General information

3.1.1 MultiInterval

MultiInterval precision means automatic switchover of the numerical increment (readability) in dependence on the applied load.

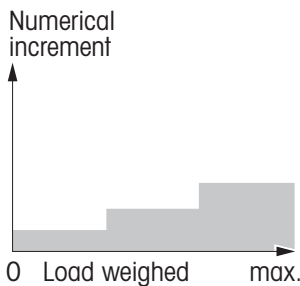

3.1.2 Single Range and High Resolution

Single Range and High Resolution mean that the numerical increments (readability) remain the same across the entire weighing range.

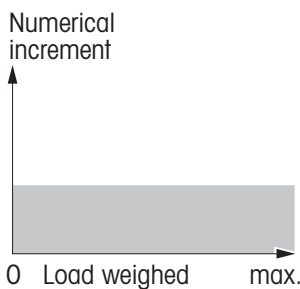

3.1.3 Additional setting options

- All other adjustment variables (adjustment to the weighing process and vibrations, as well as adjustment of stability monitoring and the zero point correction) are adjusted to the usual user conditions, however, they can be changed in the Scale menu of the weighing terminal if necessary.
- When ordering the IDNet option, the ACC409xx-SICSpro-IDNet converter including the identcard kit and a set of measuring data signs for the selectable configurations is delivered.
- If the standard configuration does not meet your needs, it is possible to reconfigure the weighing platform with the terminal. To do this, see the terminal operating instructions.
- Apply the selected configuration corresponding to the factory-mounted measuring data sign to the Identcard, and the Max-Min sign near the IDNet terminal display.
- When the configuration is changed, it is also possible to change the preload range in addition to the weighing range and the readability.

3.2 Configuration data in the factory setting

PFK989-	C300	C600	D600	D1500
Maximum capacity	300 kg	600 kg	600 kg	1500 kg
Max1 / e1	100 kg / 10 g	200 kg / 20 g	200 kg / 20 g	500 kg / 50 g
Max2 / e2	200 kg / 20 g	500 kg / 50 g	500 kg / 50 g	1000 kg / 100 g
Max3 / e3	300 kg / 50 g	600 kg / 100 g	600 kg / 100 g	1500 kg / 200 g
Zero-setting range	± 6 kg	± 12 kg	± 12 kg	± 30 kg
Preload range (typical)	54 kg	108 kg	108 kg	270 kg

PFK98 -	E1500	E3000	ES1500	ES3000
Maximum capacity	1500 kg	3000 kg	1500 kg	3000 kg
Max1 / e1	500 kg / 50 g	1000 kg / 100 g	500 kg / 50 g	1000 kg / 100 g
Max2 / e2	1000 kg / 100 g	2000 kg / 200 g	1000 kg / 100 g	2000 kg / 200 g
Max3 / e3	1500 kg / 200 g	3000 kg / 500 g	1500 kg / 200 g	3000 kg / 500 g
Zero-setting range	± 30 kg	± 60 kg	± 30 kg	± 60 kg
Preload range (typical)	270kg	540 kg	270kg	540 kg

4 Planning assemblies

4.1 Notes on planning

Due to their design characteristics, the weighing platforms are suitable for installation in conveying systems. The following specifications and dimensional drawings form the basis for the design of the required assemblies.

- The weighing platform may only be supported by the support feet, and never by the frame or lever parts.
- The weighing platform may only be permanently installed on the support feet.
- Moving or rotating parts on the weighing platform must be designed so that they do not affect the weighing result. Balance rotating parts.
- The load plate must be free on all sides so that there is no connection between the load plate and permanently mounted parts, even by falling parts or dirt deposits.
- Lay cables or hoses between the weighing platform and other machine parts so that they do not exert any force on the weighing platform.

CAUTION

When mounting assemblies, make sure that no metal chips get into the weighing platform.

→ Remove the load plate from the weighing platform before working on the load plate.

4.2 Preload range

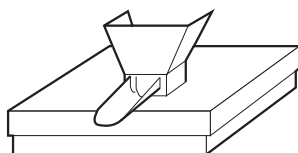

The weight of the structural parts permanently mounted on the weighing platform is referred to as "preload". The preload is electrically compensated in the weighing platform so that the full weighing range is available. The maximum preload (or the zero-setting range) that can be compensated depends on the configured weighing range.

For the preload range of the individual weighing platform refer to section "3.2 Configuration data in the factory setting" on page 19.

CAUTION

The assemblies must already be mounted when connecting the weighing platform.

4.3 Mounting possibilities

Mounting possibilities PFK98_-C300 / PBK998_-C600

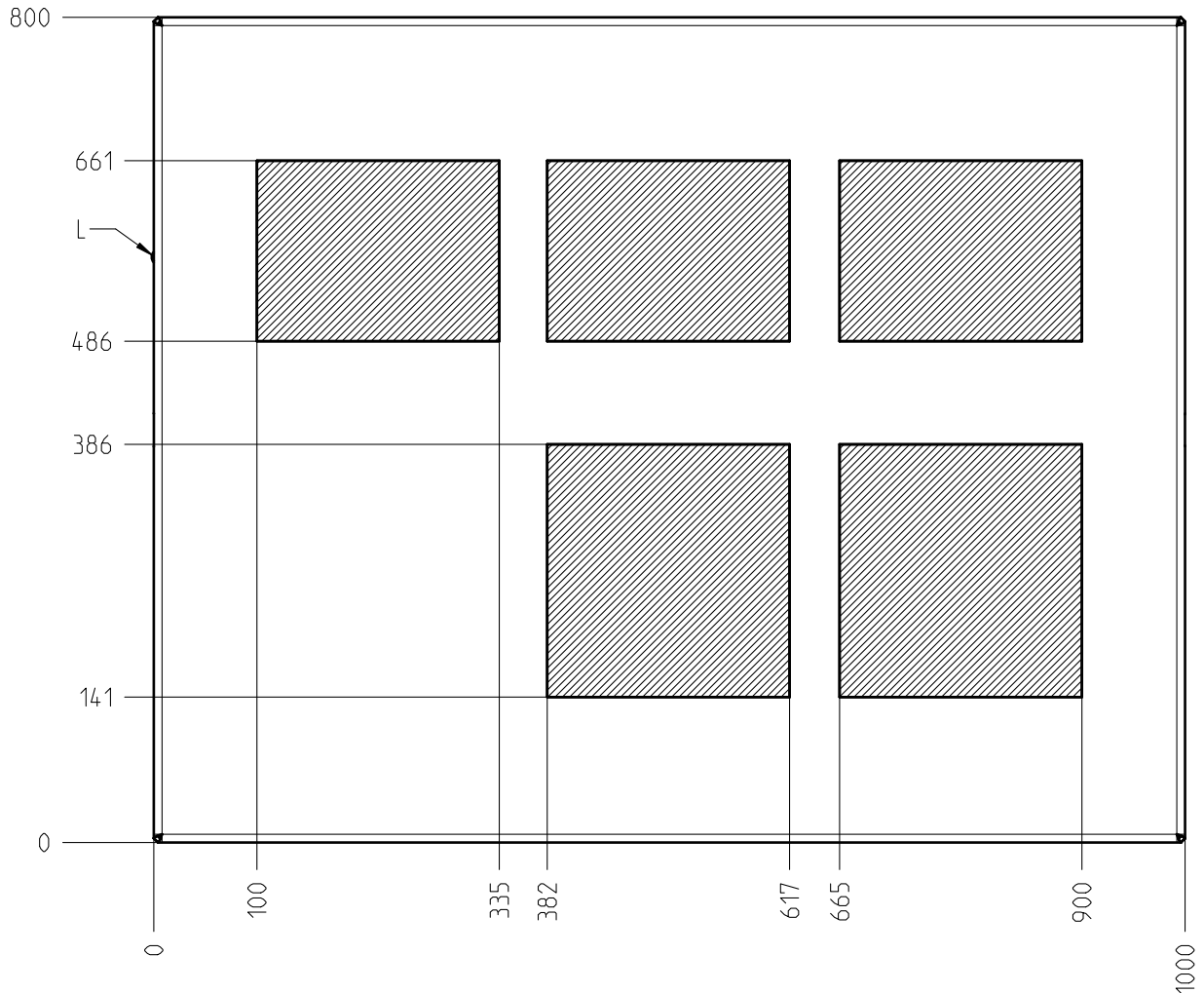

L Level bubble

Dimensions in mm

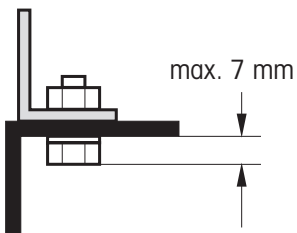

- Bridge assemblies can be mounted in the shaded areas.
Recommended mounting type: Bolting on, welding on.
- Remove the load plate and drill through for this purpose.
- Mounting parts (e.g. bolts and nuts) may extend to a maximum of 7 mm beyond the underside of the load plate.

Technical version: 11/2014

Mounting possibilities PFK98_-D600 / PBK998_-D1500

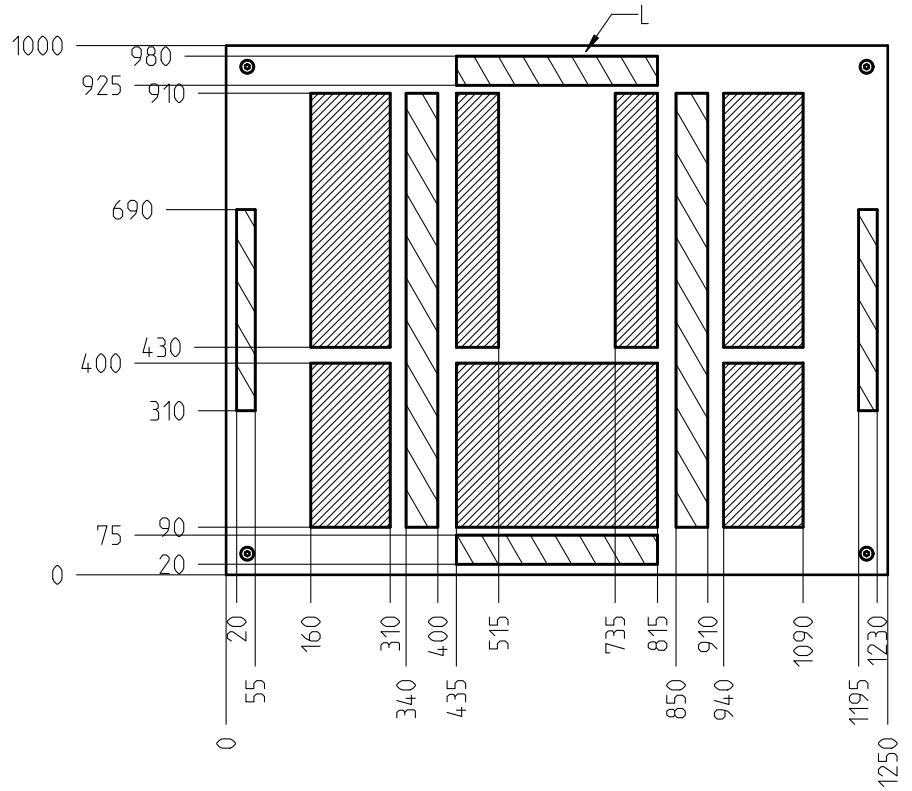

L Level bubble

Dimensions in mm

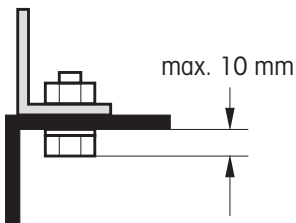

- Bridge assemblies can be mounted in the shaded areas.
Recommended mounting type: Bolting on, welding on.
- Remove the load plate and drill through for this purpose.
- Mounting parts (e.g. bolts and nuts) may extend to a maximum of 10 mm beyond the underside of the load plate.

Technical version: 11/2014

Mounting possibilities PFK98_-E1500 / PBK998_-E3000

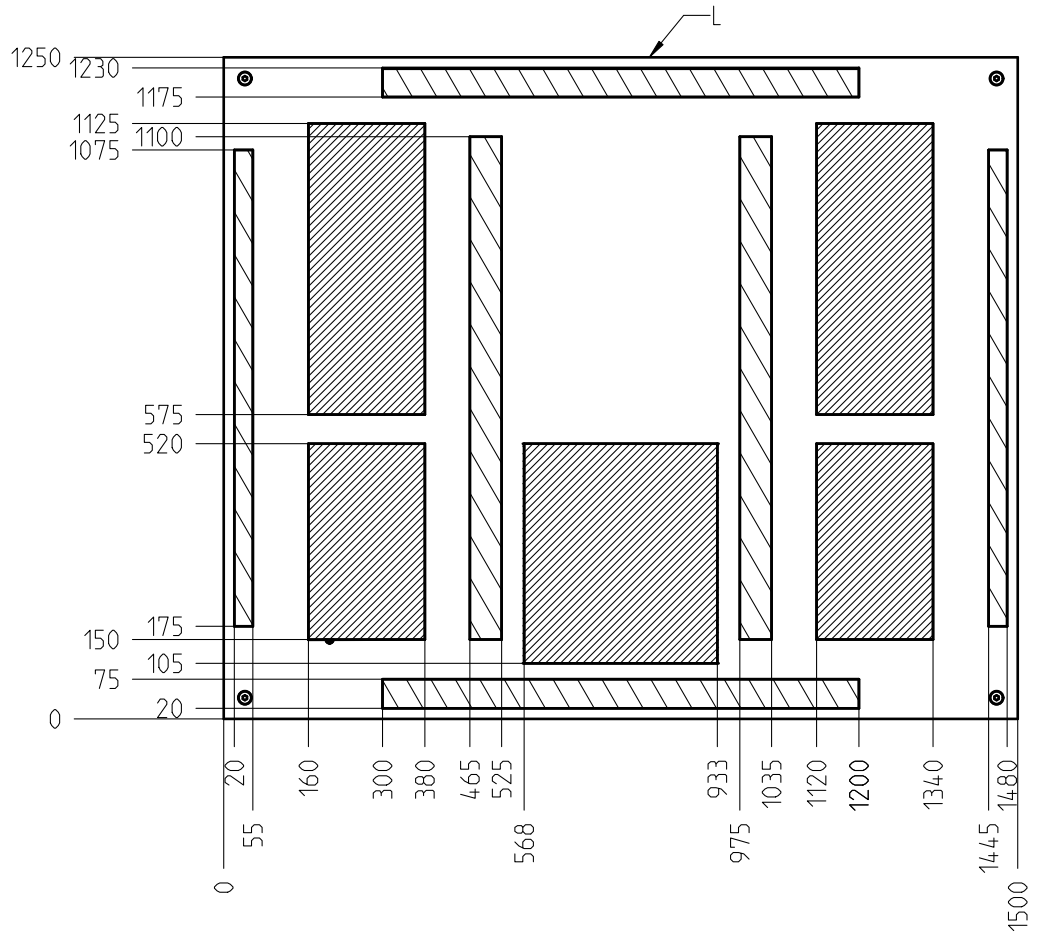

L Level bubble

Dimensions in mm

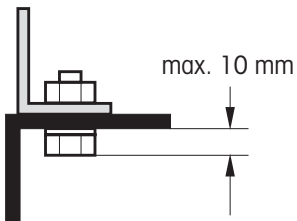

- Bridge assemblies can be mounted in the shaded areas. Recommended mounting type: Bolting on, welding on.
- Remove the load plate and drill through for this purpose.
- Mounting parts (e.g. bolts and nuts) may extend to a maximum of 10 mm beyond the underside of the load plate.

Technical version: 11/2014

Mounting possibilities PFK98_-ES1500 / PBK998_-ES3000

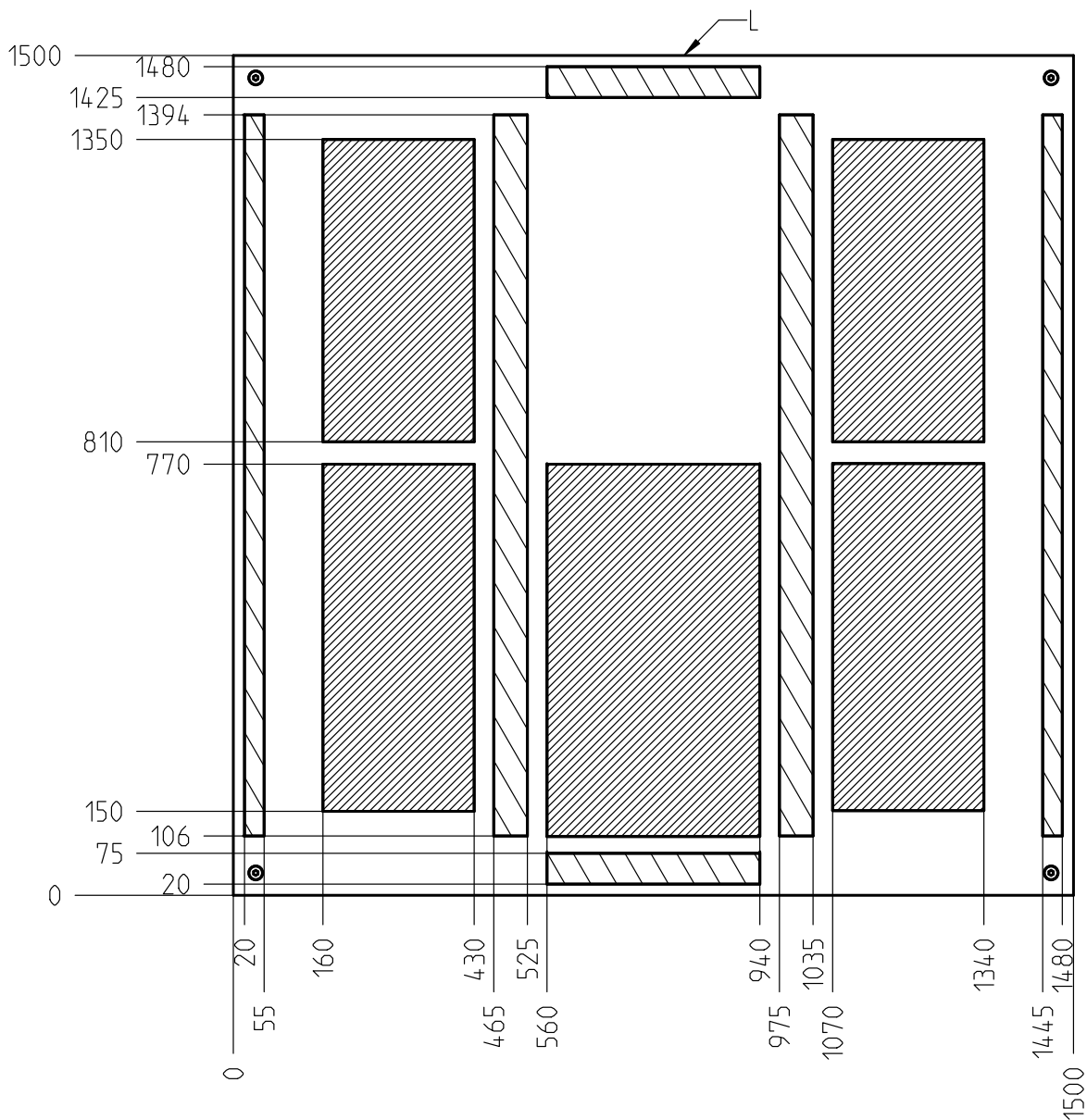

L Level bubble

Dimensions in mm

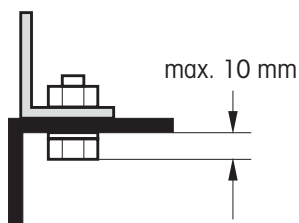

- Bridge assemblies can be mounted in the shaded areas.
Recommended mounting type: Bolting on, welding on.
- Remove the load plate and drill through for this purpose.
- Mounting parts (e.g. bolts and nuts) may extend to a maximum of 10 mm beyond the underside of the load plate.

Technical version: 11/2014

4.4 Opening possibilities

Opening possibilities PFK98_-C300 / PBK998_-C600

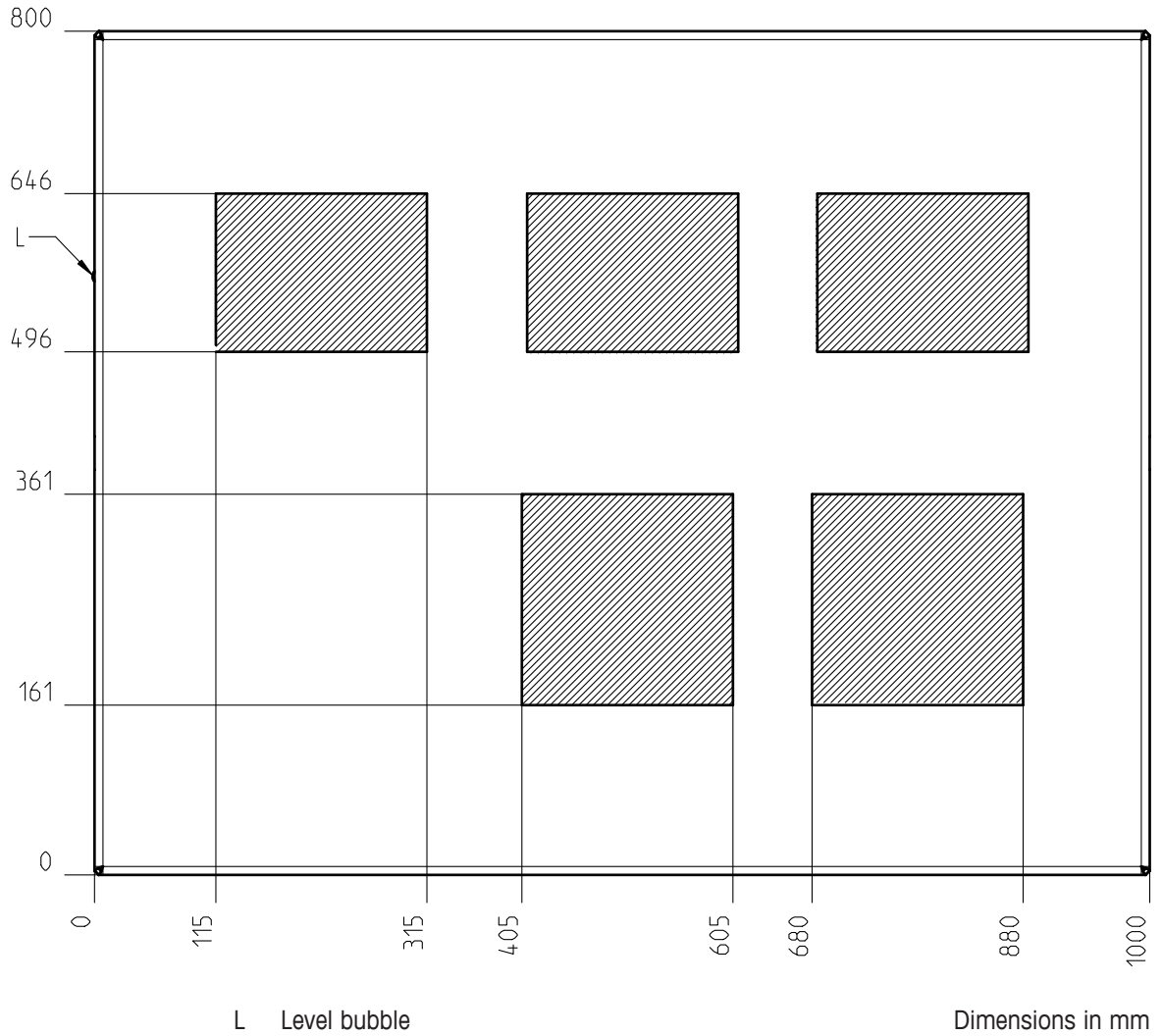

Technical version: 11/2014

Opening possibilities PFK98_-D600 / PBK998_-D1500

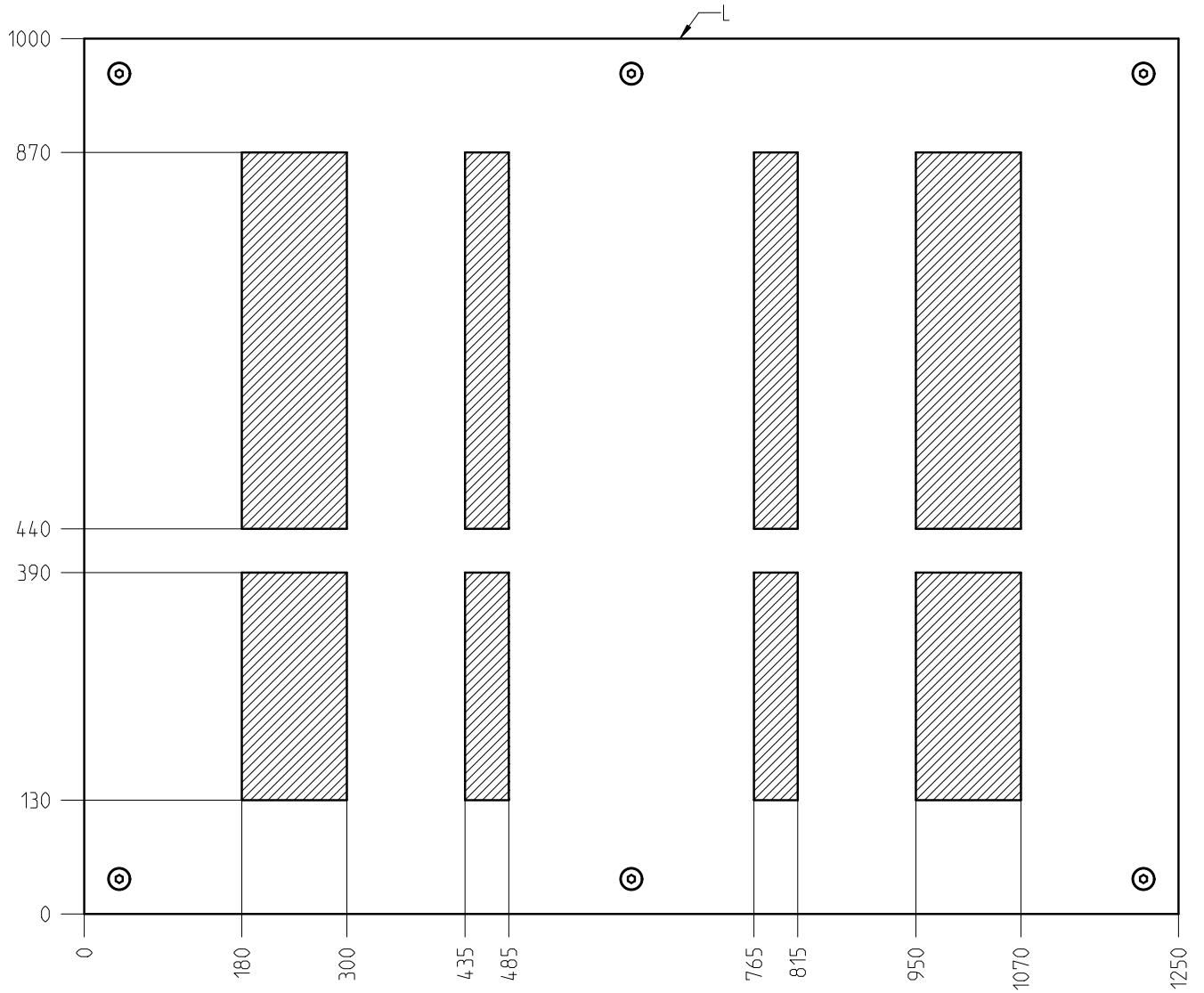

L Level bubble

Dimensions in mm

Technical version: 11/2014

Opening possibilities PFK98_-E1500 / PBK998_-E3000

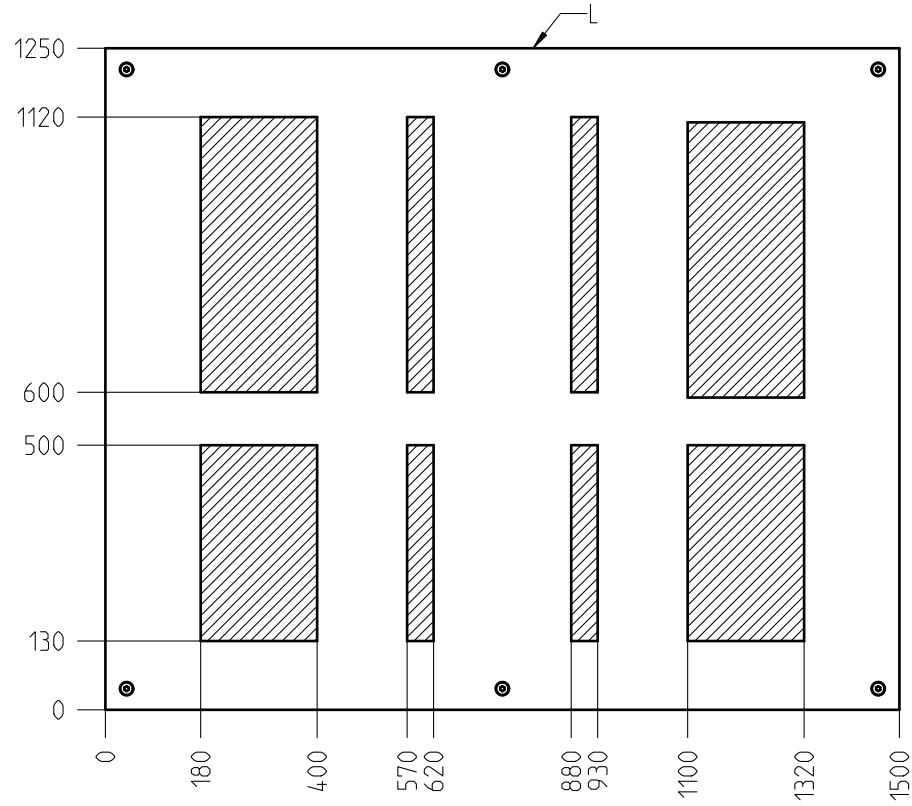

L Level bubble

Dimensions in mm

Technical version: 11/2014

Opening possibilities PFK98_-ES1500 / PBK998_-ES3000

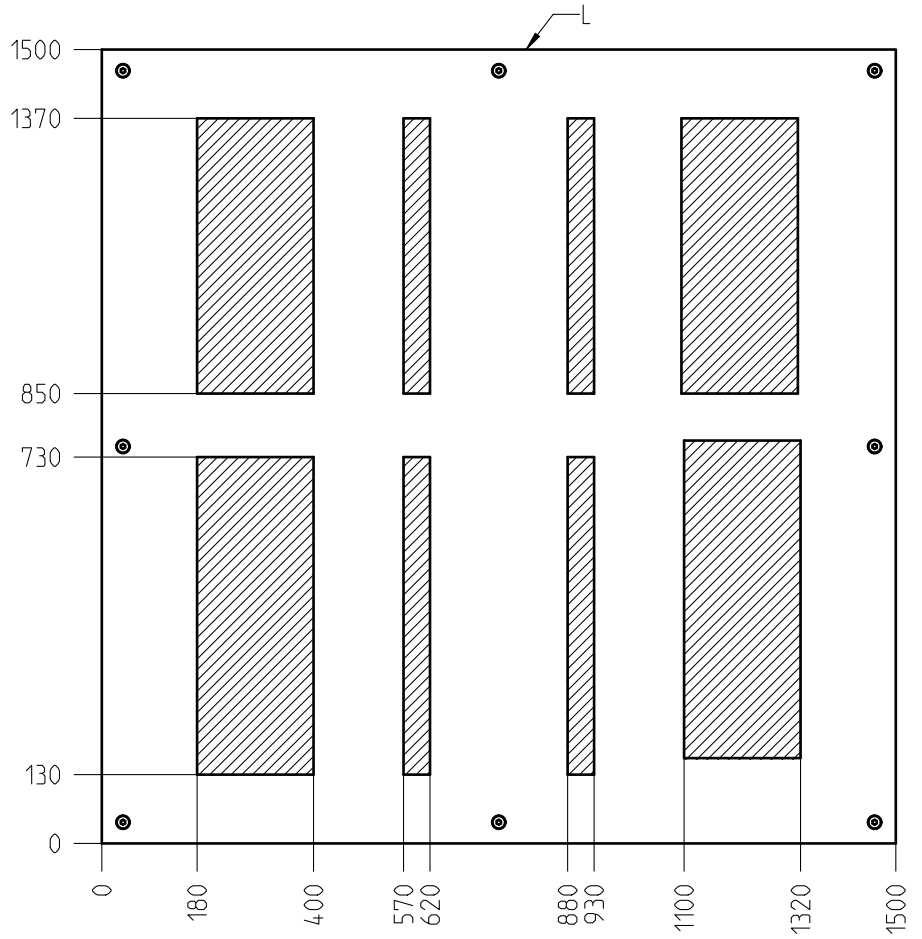

L Level bubble

Dimensions in mm

Technical version: 11/2014

5 Dimensions

Dimensions PFK98_-C300 / PBK998_-C600

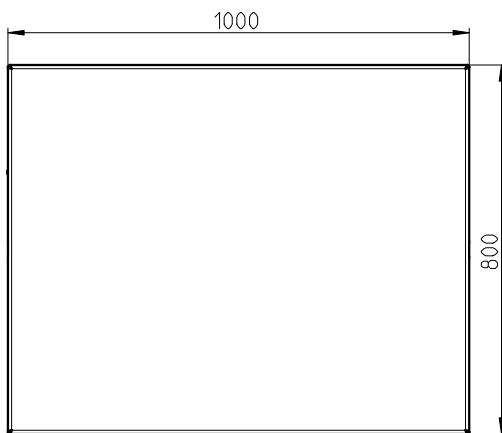
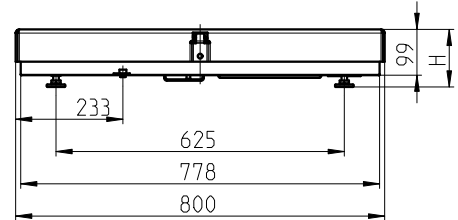
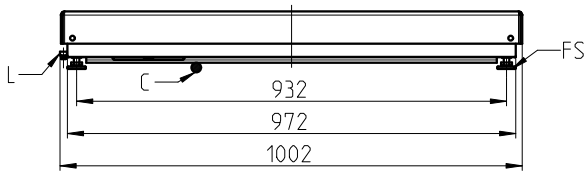

Dimensions in mm

- H Adjustable with 4 foot bolts
Min. H = 115 mm
Max. H = 140 mm
- FS Foot bolt
Required area D = 40 mm dia.
Spanner size = 19 mm
Thread = M10
- C Cable connection
- L Level bubble

Technical version: 11/2014

Dimensions PFK98_-D600 / PBK998_-D1500

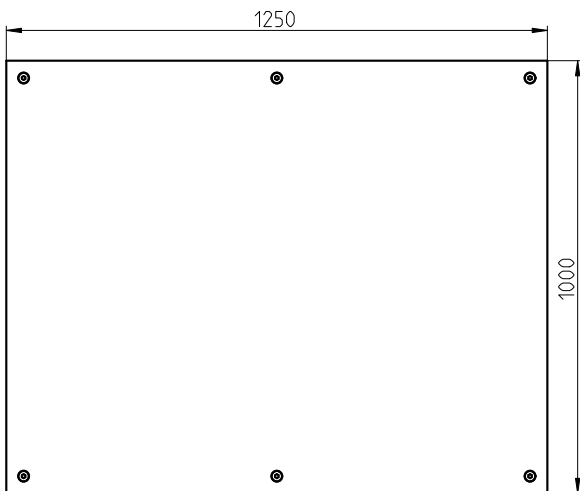
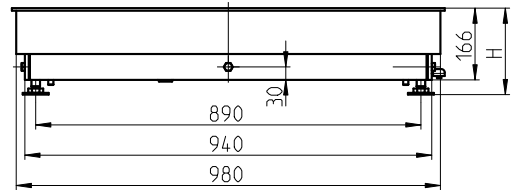
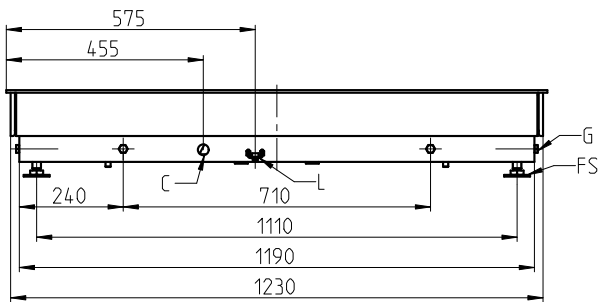

Dimensions in mm

- H Adjustable with 4 foot bolts
Min. H = 180 mm
Max. H = 205 mm
- FS Foot bolt
Required area D = 60 x 60 mm.
Spanner size = 30 mm
Thread = M12
- C Cable connection
- L Level bubble

Technical version: 11/2014

Dimensions PFK98_-E1500 / PBK998_-E3000

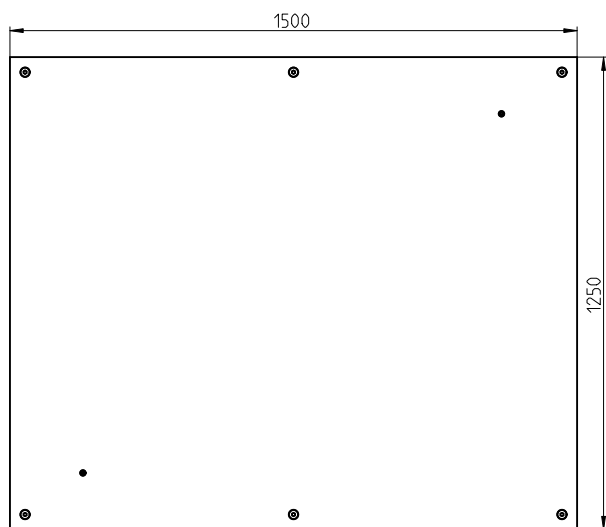
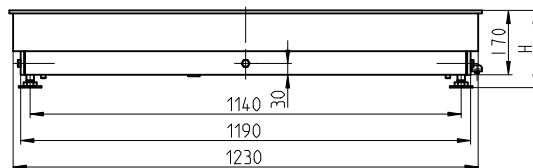
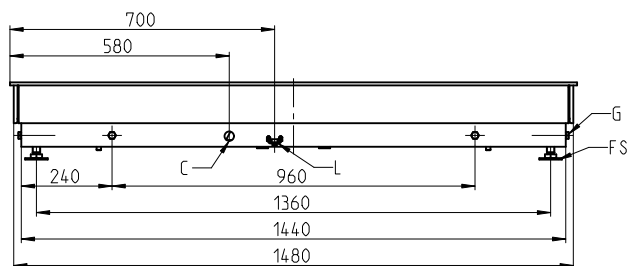

Dimensions in mm

- H Adjustable with 4 foot bolts
Min. H = 182 mm
Max. H = 207 mm
- FS Foot bolt
Required area D = 60 x 60 mm
Spanner size = 30 mm
Thread = M12
- C Cable connection
- L Level bubble

Technical version: 11/2014

Dimensions PFK98_-ES1500 / PBK998_-ES3000

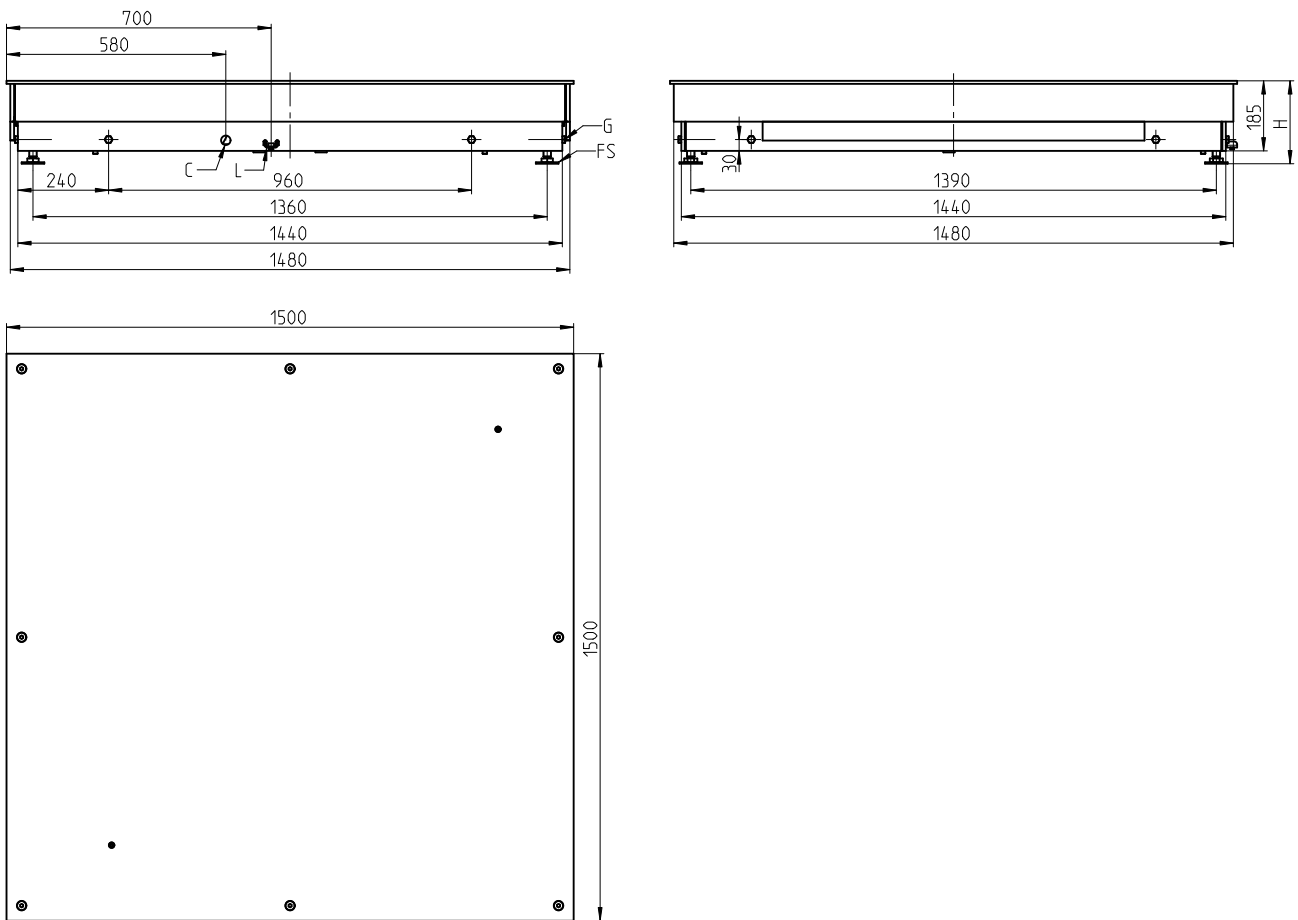

Dimensions in mm

- H Adjustable with 4 foot bolts
Min. H = 197 mm
Max. H = 222 mm
- FS Foot bolt
Required area D = 60 x 60 mm
Spanner size = 30 mm
Thread = M12
- C Cable connection
- L Level bubble

Technical version: 11/2014

www.mt.com/support

For more information

Mettler-Toledo (Albstadt) GmbH

D-72458 Albstadt

Tel. +49 7431-14 0

Fax +49 7431-14 232

www.mt.com

Subject to technical changes

© Mettler-Toledo (Albstadt) GmbH 07/2015

30233015B en



* 3 0 2 3 3 0 1 5 B *