

SCREW AIR COMPRESSOR CONTROLLER

MAM6090

USER

MANUAL

Shenzhen Plot Electronic Co., Ltd

Address: 4-5F,5 Bldg,Highstar Industry Park,Gangtou Community,
Bantian,Longgang District,Shenzhen City, China

Telephone: (+86 0755) 83173599 / 83172822 Postal code: 518129

Fax: (+86 0755) 83172966

E-mail: plt@pltsz.com

Web site: www.pltsz.com

VOTE OF THANKS

Thank you for your trustworthy and select of PLOT air compressor controller !

Shenzhen Plot Electronic Co., Ltd specializes on the manufacture and R&D of air compressor controller. We are devoted to win customer trust through our high quality products and service.

We try our best to ensure the completeness and correctness of the manual, but PLOT Company shall reserve the rights for continuous research and improvement on its products and assume no obligation for the modification and improvement on the previously delivered products. The design of products is subject to the change without notice.

Please feel free to contact our after-sale service center if you encounter any problem with our product.

You are always welcome to make suggestions and advice!

NOTICE



Please read all the operation manual before operating the set and keep this manual for further reference.



Installation of MAM** compressor controller can be performed only by professional technicians.**



Installation position shall be considered carefully in order to ensure good ventilation and reduce electromagnetic interference.



Wiring shall be performed respectively according to regulations for heavy and weak current to reduce electromagnetic interference.



RC snubber must be connected to the two terminals of coil (such as AC contactor ,valve, etc),which are controlled by relay output.



Port connection shall be inspected carefully before power on.



Correct ground connection (the third ground)can help increase product capacity of resisting signal interference.



Set rated current of motor: the max current of motor/1.2.

Features:

- **Multiple run mode optional.**
- **7 inch color screen ,with button and touch penal.**
- **Support real time power consumption and accumulative power consumption measurement.**
- **Scheduled on/off function and scheduled pressure function optional**
- **More accurate in writing frequency to control inverter through 485 communication**
- **Free to control all inverter supporting MODBUS RTU protocol.**
- **Open phase ,current overload ,current unbalance ,high voltage, low voltage protection for motor.**
- **High integration, high reliability, high cost performance**

Contents

1, Basic Operation	6
1.1 Button Explanation	6
1.2 Indicator explanation	8
1.3, Status Display and Operation	8
1.4 Run Parameter	9
1.5 User Parameter	11
1.6, Factory Parameter	14
1.7, Calibration Parameter	16
1.8, Block Parameter	17
1.9, Hardware Parameter	18
1.10 Maintenance Parameter	18
1.11 Inverter Set	19
1.12 Touch Calibration	21
1.13 Scheduled P	21
1.14 Scheduled On-Off	21
1.15 History Record	21
1.16 Motor VSD	22
1.17 Fan VSD	24
1.18 Date	26
1.19 Operation Authorization and Password	26
2, Controller Function and Technical Parameter	27
3, Model and Specifixation	28
3.1 Model Explanation	28
3.2 Power Specification Sheet for Corresponding Motor	28
4, Installation	29
4.1 Mechanical Installation	29
4.2 Controller Installation	29
5, Alarm function	32
5.1, Air Filter Alarm	32
5.2, Oil Filter Alarm	32
5.3, O/A Separator Alarm	32
5.4, Lubricant Alarm	33
5.5, Grease Alarm	33
5.6, Discharge High Temperature Alarm	33
6, Controller Protection	33
6.1 Motor Protection	33
6.2, Protection of Discharge Temperature High	33
6.3, Protection of Air Compressor Anti-reversal	33
6.4, Protection of Air compressor Open Phase	34
6.5, Protection of Air Pressure High	34
6.6, Protection of Sensor Fault	34
7, Trouble Shooting	34
8, Block Control and Network Communication	35
8.1 Block Control:	35

8.2 Network Communication.....	36
9, Inverter Control	36
10,Schematic Diagram.....	39
10.1PF.....	39
10.2PF /VSD.....	40
10.3FAN VSD.....	41
10.4MOTOR /FAN VSD	42
10.5SOFT START	43

1, Basic Operation

1.1 Button Explanation



Picture 1.1.1

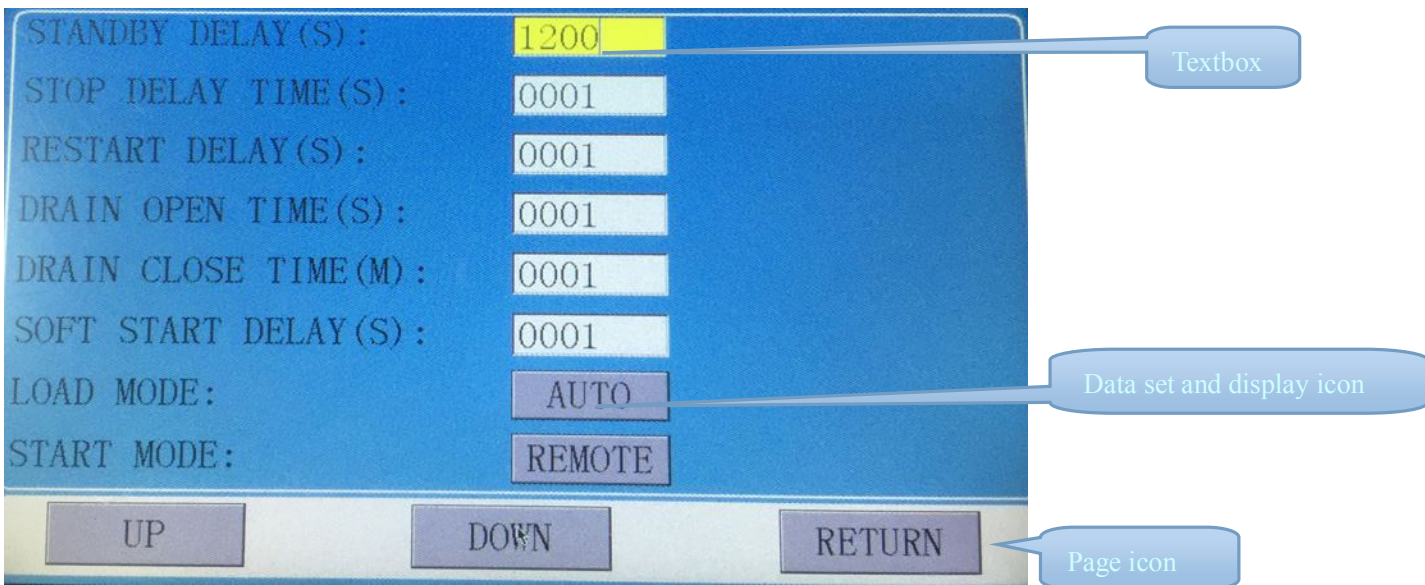



Start Button:

- When compressor is at stop status, press this button to start the compressor.
- When compressor is set as master (No.1) in block status ,press this button to start the compressor and activate block mode function at the same time.



Stop Button:

- When the compressor is at running status, press this button to stop the compressor;
- When compressor is set as master (No.1) in block status, press this button to stop compressor and block function as well;



Set Button; Load / Unload Button:

- When the compressor is at running status ,press this button to load or unload ;
- When modifying data in textbox, press this button to save data and exist modification status
- When cursor is at any page icon, press this button to execute the corresponding function.



Return Button / Reset Button:

- When the controller is at alarm and stop status, press this button for 5s to reset.
- When modifying data, press this button to exist data setting mode;
- When viewing the menu, press this button to return to previous menu;



Move Left Button:

- When checking data in textbox, press this button to enter data modifying mode, data starts to blink from right to left .
- When modifying data in textbox, press this button to move the cursor to the left data
- When modifying data in data set and display icon, press this button to modify and save the data
- When cursor is in the page icon, press this data to move to the previous icon.



Move Right Button/Enter Button:

- When checking data in textbox, press this button to enter data modifying mode, data starts to blink from left to right .
- When modifying data in textbox, press this button to move the cursor to the right data
- When modifying data in data set and display icon, press this button to modify and save the data
- When cursor is in the page icon, press this data to move to the next icon.



Move Down Button / Decreasing Button:

- When checking the data, press this button to move downward the cursor to next icon;
- When modifying data in textbox, press this button to decrease the current data
- When the current page is at run parameter, press this button to swift to the next page



Move Up Button/Increasing Button:

- When checking the data, press this button to move downward the cursor to precious icon;
- When modifying data in textbox, press this button to increase the current data

➤ When the current page is at run parameter, press this button to swift to the precious page

1.2 Indicator Explanation

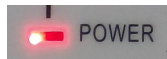

Power:

Indicator is alight when controller is powered on



Run:

Indicator is alight when motor is running

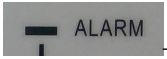

Alarm:

Indicator is blinking when controller is alarming;

Indicator is alight when compressor is alarm and stop;

Indicator is off after error is cleared and reset.

1.3, Status Display and Operation

The display screen will show as below after power on and display “MAM-6090” for a while:



After 5 seconds, the menu will switch as below:

This icon means scheduled on/off function is activated
 This icon means auto restart function is activated
 This icon means block function is activated
 Press move left or move right button to execute corresponding function
 To prevent interference, it will take 0.2S to take effect ion after press start or stop icon
 This icon means scheduled P function is activated
 This icon means remote function is activated
 This icon means computer

User can enter the below menu through clicking MENU icons on the screen or press button”



Blue means the cursor is now in this icon

User can enter the corresponding menu through clicking these icons on the screen or press button”S”

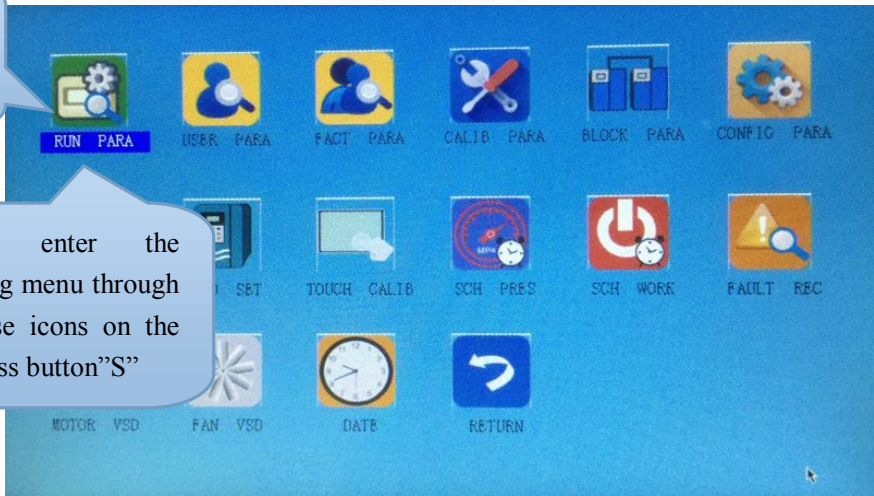

1.4 Run Parameter

Click“RUN PARAMETER”to check the relative data and set below

Menu	Preset Data	Function
STAGE 2 P	00.25MPa	Display stage 2 pressure
STAGE 2 T	-0025°C	Display stage 2 temperature
STAGE 1 P	00.00 MPa	Display stage 1 pressure
STAGE 1 T	-0050°C	Display stage 1 temperature
OIL FILTER	0020H	Record total running time of oil filter.
O/A SEPERATOR	0020H	Record total running time of O/A separator.
AIR FILTER	0020H	Record total running time of air filter .
LUBE	0020H	Record total running time of lubricant.
GREASE	0020H	Record total running time of grease.
SERIAL NO.	12345678	
MOTOR CURRENT	A: 000.0A B: 000.0A C: 000.0A	Display motor current
FAN CURRENT	A: 000.0A B: 000.0A C: 000.0A	Display fan current
PRODUCTION DATE	2016-12-01	
THIS RUN TIME	0000: 00: 00	Record compressor this run time

THIS LOAD TIME	0000: 00: 00	Record compressor this load time
SOFTWARE EDITION	CK0135M0010	
CHECK	0000 0000	
INPUT STATE	<p>1 2 3 4 5 6 7 8 9 10</p> <p>● ● ● ● ● ● ● ● ● ●</p> <p>1:In accordance with No.24 digital input state; 2:In accordance with No.23 digital input state; 3:In accordance with No.22digital input state; 4:In accordance with No.21 digital input state; 5:In accordance with No.20digital input state; 6:In accordance with No.19digital input state;</p> <p>Red circle of input state means terminal is connected; Orange circle of input state means terminal is disconnected</p>	
OUTPUT STATE	<p>1 2 3 4 5 6 7 8 9 10</p> <p>● ● ● ● ● ● ● ● ● ●</p> <p>1: In accordance with No.43 digital output state; 2: In accordance with No.42 digital output state; 3: In accordance with No.41 digital output state; 4: In accordance with No.40digital output state; 5: In accordance with No.39digital output state; 6: In accordance with No.37digital output state;</p> <p>Red circle of input state means terminal is connected; Orange circle of input state means terminal is disconnected</p>	
MOTOR RATED SPEED	0000 RPM	Display motor actual speed based on the calculation of motor frequency read
MOTOR RATED POWER	000.0 Hz	Display the output frequency of current motor inverter
MOTOR OUTPUT CURRENT	000.0 A	Display the output current of current motor inverter
MOTOR OUTPUT VOLTAGE	000.0 V	Display the output voltage of current motor inverter
MOTOR OUTPUT POWER	000.0 Kw	Display the real time output power of current motor inverter
MOTOR THIS POWER CONSUMPTION	0000000.0Kw.H	Display the accumulative this power consumption based on the motor inverter real time output power
MOTOR TOTAL POWER CONSUMPTION	0000000.0Kw.H	Display the accumulative total power consumption based on the motor inverter real time output power
MOTOR STATE DISCRPTION	0000	Display in the controller motor status area based on the running status register data reads from motor inverter

ERROR DISCRIPTION	0000	Display in the controller error area based on the running error register data read from motor inverter
WRITE FREQUENCY	000.0	Display the motor frequency based on PID calculation
FAN SPEED	0000 RPM	Display the fan real time speed based on the fan frequency read
FAN OUTPUT FREQUENCY	000.0 Hz	Display the output frequency of current fan inverter
FAN OUTPUT CURRENT	000.0 A	Display the output current of current fan inverter
FAN OUTPUT VOLTAGE	000.0 V	Display output voltage of current fan inverter
FAN OUTPUT POWER	000.0 Kw	Display the real time output power based on the current fan inverter.
FAN THIS POWER CONSUMPTION	000000.00Kw.H	Display the accumulative this power consumption based on the fan inverter real time output power
FAN TOTAL POWER CONSUMPTION	000000.00Kw.H	Display the accumulative total power consumption based on the fan inverter real time output power
FAN STATE DISCRIPTION	0000	Display in the controller fan status area based on the running status register data reads from fan inverter
ERROR DISCRIPTION	0000	Display in the controller error area based on the running error register data read from fan inverter
WRITE FREQUENCY	000.0	Display the frequency based on the PID calculation
PF MOTOR ØUI	000000.0Kw.H	
PF MOTOR THIS POWER CONSUMPTION	0000000.0Kw.H	When set as PF, Display the compressor this time power consumption(FYI)
PF MOTOR TOTAL POWER CONSUMPTION	0000000.0Kw.H	When set as PF, Display the motor total power consumption(FYI)
PF FAN ØUI	000000.0 Kw.H	
PF FAN THIS POWER CONSUMPTION	0000000.0Kw.H	When set as FAN PF, Display the fan this time power consumption(FYI)
PF FAN TOTAL POWER CONSUMPTION	0000000.0Kw.H	When set as FAN PF, Display the fan total power consumption(FYI)

1.5User Parameter

User parameter is used to store relative data. User password is required for modification.

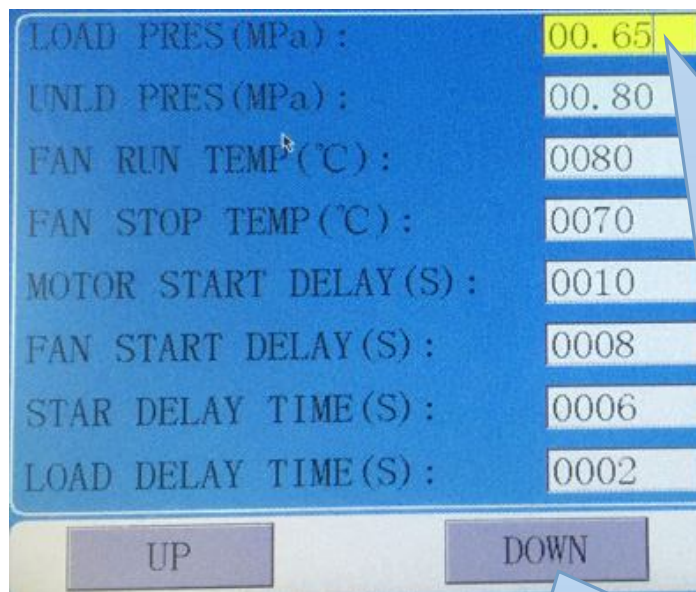

Touch operation: (base is yellow)

1, When the cursor is fixed here ,you can revise the parameter by clicking the data box directly if the password has been verified already

2, If the password is not verified yet, a password verification box will prompt .Button operation shows as below

1, In data checking mode, press left or right button to enter data modification mode;

2, In data checking mode, press up or down button to move the cursor to next icon;

3, In data modification mode, press up or down button to revise current data;

4, In data modification mode, press left or right button to move the cursor to next data bit

When the cursor is in page icon, press “S” to execute corresponding function

Main function is below:

Menu	Preset Data	Function
LOAD P (MPa):	00.65	1,In AUTO load mode , compressor will load if pressure is below this set data 2,In STANDBY mode, compressor will start if the pressure is below this set data
UNLOAD P (MPa):	00.80	1,Compressor will unload automatically if air pressure is above this set data 2.This data should be set above LOAD P ,also should be set below UNLD P LIM
FAN START T (°C):	0080	Fan will start if DISC T is above this set data
FAN STOP T (°C):	0070	Fan will stop if DISC T is below this set data
MOTOR START DELAY (S):	0008	Set the MOTOR START TIME. Record time when motor is activated, controller will not start overload protection during this time to avoid impulse starting current stopping the motor.
FAN START DELAY (S):	0003	Set the FAN START TIME. Record time when fan is activated, controller will not start overload protection during this time to avoid impulse starting current stopping the fan.
STAR DELAY (S):	0006	Interval time from star start to delta start.
LOAD DELAY (S):	0002	Unloading in this set time after enter delta running
STANDBY DELAY (S):	0600	When unloading continuously, compressor will automatically stop and enter to standby status if over this set time
STOP DELAY (S):	0010	For NORMAL STOP operation, compressor will stop after it continuously unloads over this set time

RESTART DELAY (S):	0100	Machine can start only over this set time at any case(after normal stop, standby or alarm &stop)
DRAIN OPEN TIME (S) :	0002	Auto drain control, continuously drain time
DRAIN CLOSE TIME (M):	0060	Auto drain control, continuously drain interval time
SOFT START DELAY (S):	0006	Controller starts LOAD DELAY TIME after SOFT-START DELAY (this data is only available in SOFT START mode)
LOAD MODE:	MANUAL/AUTOMATIC	MANUAL : only when the pressure is above UNLD P, compressor will unload automatically .For any other case ,the Load/Unload function can only be executed by pressing “load/unload” key. AUTOMATICAL: the load/unload function can be executed by the fluctuation of AIR P automatically
START MODE:	LOCAL/REMOTE	LOCAL :only the button on the controller can turn on and turn off the machine. REMOTE: both the button on the controller and the remote control button can turn on and turn off the machine; Note: When one input terminal is set as REMOTE START ENABLE, start mode is controlled by hardware status. It is remote when terminal is close, it is local when terminal is open. In this case, the set here is not available.
RUN MODE:	PF/MOTOR VSD/FAN VSD/MOTOR FAN VSD/SOFT START	Choose the corresponding compressor run mode according to customer requirement and choose the corresponding schematic diagram for reference.
COM ADD:	0001	Set the communication address in COMPUTER or BLOCK mode. This address is unique for every controller in net
BACKLIGHT ADJUSTMENT :	0001	Adjust the backlight, the higher the data, the brighter the display(from level 1 to level 4)
COM MODE:	COMPUTER/BLOCK/DISABLE	DISABLE: communication function is not activated. COMPUTER: compressor can communicate with computer or DCS as slave according to MODBUS-RTU. Baud rate:9600;Data format:8N1;Parity bit: even parity check BLOCK: compressors can work in a net
PRESSURE UNIT:	MPa/PSI/BAR	MPa: pressure unit displays as MPa PSI: pressure unit displays as PSI BAR: pressure unit displays as BAR
TEMPERATURE UNIT:	°C/°F	°C:temperature unit displays as °C °F :temperature unit is displays as °F
LANGUAGE:	CHINESE/ENGLISH	ENGLISH: Displays in English CHINESE: Displays in Chinese
USER PASSWORD:	****	User could modify the user password by old user password or factory password

SLEEP BACKLIGHT	0007	Adjust the backlight when no operation in a long time
-----------------	------	---

1.6,Factory Parameter

Factory parameter is used to store relative data. Factory password is required for check and modification.

The modification of factory parameter is same with customer parameter. Main function is below.

Menu	Preset Data	Function
MOTOR RATED CURRENT (A):	Maximum motor overload data /1.2	When the current of motor is more than 1.2 times of the set data , the unit will stop for overload feature. (see table2.1.1)
FAN RATED CURRENT (A):	Maximum fan overload data/1.2	When the current of fan is more than 1.2 times than the set data , the unit will stop for overload feature.
STAGE 1 ALARM T (°C):	0105	When stage 1 alarm temperature reaches this set data, compressor will alarm
STAGE 2 STOP T (°C):	0110	When stage 2 alarm temperature reaches this set data, compressor will alarm and stop
STAGE 1 ALARM T	0105	When stage 1 alarm temperature is higher than this set data, compressor will alarm
STAGE 2 STOP T	0115	When stage 2 stop temperature is higher than this set data, compressor will alarm and stop
STAGE 2 STOP P (MPa):	00.90	When stage 2 stop pressure reaches this set data ,compressor will alarm and stop
STAGE 1 STOP P (MPa): :	01.00	When stage 1 stop pressure is higher than this set data, compressor will alarm and stop
UNLD P LIM (MPa):	00.85	This data is the maximum of UNLD P. The UNLD P in the customer parameter must be set no higher than this data.
CURRENT UNBALANCE:	0006	When $\text{MAX -MIN CURRENT} \geq (1 + \text{SET DATA} * \text{MIN CURRENT} / 10)$,the unbalance protection is activated ,compressor will alarm and stop, reporting MOTOR CURR UNBAL If the set data ≥ 15 , the unbalance protection will not be activated.
OPEN PHASE PROT (S):	002.0	If OPEN PHASE protection ≥ 20 seconds, OPEN PHASE protection is not activated
FAULT RECORD RESET:	****	Input"8888"and press "set" button to clear all the history fault record.
ALARM LONG STOP (H):	0000	When controller detects oil filter, air filter, O/A separator lubricant and grease running over the max time and alarm over the data set, compressor will alarm and stop

MAX RUN TIME (H):	0000	1, When the compressor is in a stop status and the TOTAL RUN TIME is over this MAX TIME set, compressor will alarm and stop, reporting USER MISTAKE 2, Set the data to '0000', this function is not activated.
FACTORY PASSWORD 2:		Set a FACTORY PASSWORD which can be modified.
HIGH VOLTAGE (V):	0410	When voltage is detected higher than HIGH VOLTAGE, the controller will alarm and stop When set as 0000, HIGH VOLTAGE protection function is not activated.
LOW VOLTAGE(V):	0350	When voltage is detected lower than LOW VOLTAGE, the controller will alarm and stop When set as 0000, LOW VOLTAGE protection function is not activated.
VSD COM OVERTIME (S):	002.0	Record time when controller sent first data, if controller failed to receive the feedback from inverter within this set time, controller is regarded overtime and will send command again.
VSD COM INTERRUPT (S):	0020	If controller failed to receive feedback from inverter for this set time, VSD COM is interrupted.
VSD COM RESTORE:	0015	After VSD COM is interrupted, and controller receives the correct data more than this set times, VSD COM is regarded restored.
SCHEDULED ON/OFF:	DISABLE/ENABLE	ENABLE: SCHEDULED ON/OFF is valid DISABLE: SCHEDULED ON/OFF is invalid
SET P SECTION :	DISABLE/ENABLE	ENABLE: S SET P SECTION is valid DISABLE: SET P SECTION is invalid
TOTAL RUN TIME (H):	000100 H:00M	Revise total run time
TOTAL LOAD TIME (H)	000095 H:00M	Revise total load time
LOW TEMP PRO (°C)	-0050	After power on,if the temperature is detected lower than the set data,it is not allowed to turn to.Two minutes after power on, if the temperature is detected lower than the set data,it is reported temperature sensor fault and stop.
AUTO RESTART	DISABLE/ENABLE	Set the function of auto restart after power on again
PF MOTOR POWER COEF	1.72	Set the coefficient for the calculation of motor power.
MOTOR PF POWER CONSUMPTION (Kw.H)	0000000.0	Set and modify the motor power consumption in PF mode
PF FAN POWER COEF	1.72	Set the coefficient for the calculation of fan power.
FAN PF POWER CONSUMPTION (Kw.H)	000000.00	Set and modify the fan power consumption in PF mode

FREQ SELECT	50HZ	Set the power frequency
OIL PRES DIFF ALARM (MPa)	00.15	In loading mode,when air pressure and tank pressure are all above 0.5Mpa,and tank pressure-air pressure- line pressure resistance> oil pres diff alarm, controller will alarm
OIL PRES DIFF STOP (MPa)	00.20	In loading mode,when air pressure and tank pressure are all above 0.5Mpa,and tank pressure-air pressure- line pressure resistance> oil pres diff stop, controller will stop
REAR BEARING ALARM T (°C)	0000	When rear bearing stop temperature is above this set data, compressor will alarm
REAR BEARING STOP T (°C)	0001	When rear bearing stop temperature is above this set data, compressor will alarm and stop
LINE PRESSURE RESISTANCE (MPa)	00.05	line pressure resistance
SERIAL NO.	12345678	Factory serial number
PRODUCTION DATE	2015-01-01	Factory production date

1.7,Calibration Parameter

Calibration parameter is used to store relative data. Calibration password is required for check and modification. Main function is below.

Menu	Preset Data	Function
MOTOR A COEF	1.000	Input the coefficient to calibrate current. Controller display current=sample current*coefficient. The range of coefficient: 0.800-2.000
MOTOR B COEF	1.000	
MOTOR C COEF	1.000	
FAN A COEF	1.000	
FAN B COEF	1.000	
FAN C COEF	1.000	
T 1 COEF	1.000	Input the coefficient when calibrate discharge temperature. Controller display temperature=sample temperature*coefficient. The range of coefficient: 0.800-2.000
T 2 COEF	1.000	Note:this parameter is reserved in MAM6090
T 3 COEF	1.000	
T 4 COEF	1.000	
T 5 COEF	1.000	
T 6 COEF	1.000	
P 1 COEF	1.000	Input the coefficient to calibrate air pressure. Controller display pressure =sample pressure*coefficient. The range of coefficient:0.800-2.000
P 2 COEF	1.000	Note:this parameter is reserved in MAM6090
P COEF	1.000	Input the coefficient to calibrate air pressure. Controller display pressure =sample pressure*coefficient. The range of coefficient:0.800-2.000

P1 RANGE (MPa)	0002	
P2 RANGE (MPa)	0002	
T 1 ZERO	0002	Calibrate controller temperature zero. Calibrate temperature to -20°C when controller pressure sensor terminal connects the resistance in accordance with -20°C. For the calibration of temperature, it is required to calibrate T zero first and then calibrate coefficient
T 2 ZERO	0002	Note:this parameter is reserved in MAM6090
T 3 ZERO	0002	
T 4 ZERO	0002	
T 5 ZERO	0002	
T 6 ZERO	0002	
P 1 ZERO	0002	When AIR P is below this set value, the pressure is displayed as 0.00.It is used to avoid air pressure transmitter from increasing.
P 2 ZERO	0002	When P 2 is below this set value, the pressure is displayed as 0.00.It is used to avoid pressure zero from increasing.
P1 RANGE	0002	
P2 RANGE	0002	
PHASE PROT (V)	000.9	If the Three phase voltage is detected lower than the data set here, controller will report PHASE WRONG If PHASE PROT =0 second, PHASE PROT is not activated
OPEN PHASE PROT (V)	000.0	If the open phase voltage is detected lower than the data set here,controller will report PHASE WRONG If OPEN PHASE protection =0 second, OPEN PHASE protection is not activated Note:this parameter is reserved in MAM6090
MOTOR CURR RATIO	020	Motor rated current/5
FAN CURR RATIO	001	Fan rated current /2.5
STANDBY		For manufacturer calibration

1.8, Block Parameter

Block parameter is used to store relative data. Block password is required for check and modification. Main function is below.

Menu	Preset Data	Function
BLOCK NUMBER	0002	Number of air compressors in block net
BLOCK LOAD P (MPa)	00.63	In BLOCK mode, one compressor will start or load when master AIR P is below this set data
BLOCK UNLOAD P (MPa)	00.78	In BLOCK mode, one compressor will stop or unload when master AIR P is above this set data
BLOCK DELAY (S)	0020	In BLOCK mode, when master sends two commands continuously, second command signal delays for this set data

TURN TIME (M)	0060	When master pressure is between BLOCK LOAD P and BLOCK UNLD P, master determines slave to work alternatively after working over this set time
BLOCK MODE	PF-PF VSD-PF VSD-VSD	PF-PF:PF compressor and PF compressor work in block mode VSD-PF: VSD compressor and PF compressor work in block mode VSD-VSD: VSD compressor and VSD compressor work in block mode

1.9,Hardware Parameter

Hardware parameter is used to set the function from 17~24 31 32 33 terminals. Main function is below

Menu	Preset Data	Function
24 TERMINAL:	EMERGENCY	NO FUNCTION/EMERGENCY/REMOTE ON/REMOTE OFF/REMOTE INCHING/KEEP REMOTE / LACK WATER (N.C.)/REMOTE LOAD/REMOTE START ENABLE/REMOTE LOAD/UNLD /TANK HIGH T (N.C.)/ COIL HIGH T (N.C.)/ BEARING HIGH T (N.C.)/ ELEC FAULT (N.C.)/MOTOR OVLD (N.C.)/FAN OVLD (N.C.)/OIL BLOCK (N.C.)/ OIL BLOCK (N.O.)/ O/A BLOCK (N.C.)/O/A BLOCK (N.O.)/AIR FILTER BLOCK (N.C.)/AIR FILTER BLOCK (N.O.)/ AIR FAULT (N.C.)/DRYER FAULT (N.C.)/ MOTOR INV FAULT (N.O.)/ MOTOR INV FAULT (N.C.)/ FAN INV FAULT (N.O.)/ FAN INV FAULT (N.C.)。 Note: User can set different digital input function
23 TERMINAL:	/	
22 TERMINAL:	LACK WATER	
21 TERMINAL:	OIL FILTER	
20 TERMINAL:	O/A SEPERATOR	
19 TERMINAL:	AIR FILTER	
18 TERMINAL:	MULTIFUNCTIONAL	
17 TERMINAL:	REMOTE ON-OFF	
33 RELAY FUNCTION:	RUN	NO FUNCTION/ALARM/RUN/FAULT/READY/REMOTE/ START MOTOR INVERTER/START FAN INVERTER Note: User can set different relay output function
32 RELAY FUNCTION:	FAULT	
31 RELAY FUNCTION:	ALARM	

1.10Maintenance Parameter

Maintenance parameter is used to store maintenance data. Maintenance password is required for check and modification. Main function is below.

Menu	Preset Data	Function
OIL FILTER RUN TIME(H)	0000	Record total running time of oil filter. If changing new oil filter, the data should be reset by manual operation.

O/A SEPERATOR RUN TIME(H)	0000	Record total running time of O/A separator. If changing new O/A separator, the data should be reset by manual operation
AIR FILTER RUN TIME(H)	0000	Record total running time of air filter .If changing new air filter, the data should be reset by manual operation
LUBRICANT RUN TIME(H)	0000	Record total running time of lubricant. If changing new lubricant, the data should be reset by manual operation
GREASE RUN TIME (H)	0000	Record total running time of grease. If changing new grease, the data should be reset by manual operation
OIL FILTER MAX RUN TIME (H)	2000	1, Alarm prompt when total running time of oil filter is above the set data . 2,Set this data to “0000” , alarm function for oil filter running time is not activated
O/A SEPERATOR MAX RUN TIME(H)	2000	1, Alarm prompt when total running time of O/A separator is above the set data. 2,Set this data to “0000” ,alarm function for O/A separator running time is not activated
AIR FILTER MAX RUN TIME (H)	2000	1, Alarm prompt when total running time of air filter is above the set data. 2,Set this data to “0000” , alarm function for air filter running time is not activated
LUBRICANT MAX RUN TIME (H)	2000	1, Alarm prompt when total running time of lubricant is above the set data. 2, Set this data to “0000”, alarm function for lubricant running time is not activated.
GREASE MAX RUN TIME (H)	2000	1, Alarm prompt when total running time of grease is above the set data. 2,Set this data to “0” , alarm function for grease running time is not activated

1.11 Inverter Set

Inverter set is used to set inverter data. Inverter password is required for check and modification. Main function is below.(The following chart is an example of Shneider inverter ATV61、ATV71)

Menu	Preset Data	Function
INVERTER NAME:	0ATV61	Set inverter name, communicate any inverter supporting modbus
RUN(W) ADD1:	2135	Corresponding address 1 of inverter start command
RUN VALUE:	0001	This data is inverter start data (please refer to communication chapter in inverter manual for different inverter.)
RUN(W) ADD2:	2135	Corresponding address 2 of inverter start command
RUN VALUE:	0001	This data is inverter start data (please refer to communication chapter in inverter manual for different inverter.)

STOP(W) ADD:	2135	Corresponding address of inverter stop command
RUN VALUE:	0001	This data is inverter start data (please refer to communication chapter in inverter manual for different inverter.)
RESET(W) ADD:	2135	Corresponding address of inverter reset command
RUN VALUE:	0001	This data is inverter start data (please refer to communication chapter in inverter manual for different inverter.)
FREQ(W) ADD:	2136	Corresponding register address of inverter running frequency source
FREQ(R) =	$REC * 0001 \div 0001$	The REC value is frequency value with one decimal. Use formula to transfer to corresponding value based on different inverter and send it to inverter. Example: 50HZ running frequency, REC value:500 For inverter with write frequency of 2 decimals, formula: $REC * 0001 \div 0010$ For inverter with write frequency of 1 decimal, formula: $REC * 0001 \div 0001$ For the inverter whose max output frequency is in corresponding with 10000, the formula : $REC * 0020 \div 0001$
STATE(R) ADD:	2135	Read inverter running status address
RUN S =	R AND $0001 = 0001$	Check if inverter has run the formula (please refer to communication chapter in inverter manual)
COM FORM	8N1-N	Set the data format of controller and inverter communication. This set should be consistent with inverter communication format 8N1-N: 1start bit,8 data bits,1 stop bit, no parity bit 8N1-E: 1start bit,8 data bits,1 stop bit, even parity bit 8N1-O: 1start bit,8 data bits,1 stop bit, odd parity bit 8N2-N: 1start bit,8 data bits,2 stop bit, no parity bit Note: Communicate with inverter, the baud rate is fixed:9600
FREQ(R) ADD	0C82	Read inverter frequency address (refer to inverter manual)
FREQ(R) =	$REC * 0001 \div 0001$	Calculate inverter frequency formula. Controller will transfer the frequency to one decimal.
VOLT(R) ADD	0C88	Read inverter voltage address
VOLT(R) =	$REC * 0001 \div 0001$	Calculate inverter voltage formula. Controller will transfer the voltage to one decimal
CURR(R) ADD	0C84	Read inverter current address
CURR(R) =	$REC * 0001 \div 0001$	Calculate inverter current formula. Controller will transfer the current to one decimal
POWE(R) ADD	0C8B	Read inverter power address

POWE(R)	REC*S*0001÷01 00	Calculate inverter power formula. Controller will transfer the power to one decimal
ERR ADD	6500	Read inverter error address
ERR S =	R AND 0000≠0000	Inverter reports error formula or not
EMERGENCY ADD	2135	Corresponding add of inverter emergency stop command
RUN VALUE	0001	This data is inverter start data (please refer to communication chapter in inverter manual for different inverter.)

1.12 Touch Calibration

Touch calibration is used to adjust touch accuracy. Touch calibration password is required for adjustment. After entering touch calibration menu, use fingertip or other tool with sharp head to click A ,B ,C ,D in sequence. Press “S” button to restart and save the modification ; If user wants to calibrate again, press reset button and reset following precious step.

1.13 Scheduled P

Scheduled P is used to set scheduled pressure. Scheduled P password is required for check and modification. Main function is below.

Menu	Preset Data	Function
LOAD P (MPa):	00.65	During P START TIME and P STOP TIME, compressor will load if AIR P is below this set data
UNLOAD P (MPa):	00.80	During P START TIME and P STOP TIME, compressor will unload if AIR P is above this set data
SCHEDULED VSD P (MPa):	00.70	During P START TIME and P STOP TIME, set AIR P in VSD mode to keep running stable. When pressure is fluctuated around this data, controller will adjust operating frequency of inverter to control the pressure close to this data(This data is only available in MOTOR VSD or MOTOR/FAN VSD mode)
P START TIME	00:00	Set this data to activate P SECTION SEL function. Set this data to “0”, this function is not activated
P STOP TIME	00:00	Set this data to activate P SECTION SEL function. Set this data to “0”,this function is not activated

1.14 Scheduled On-Off

Scheduled On-Off is used to set one week scheduled on-off time, four period is allowed to set in one day. Scheduled On-Off password is required for check and modification. Main function is below. When set to 00:00, the correspondent function is invalid.

1.15 History Record

Record history fault for user to find causes and solutions. 100 items are allowed to record.

1.16 Motor VSD

Motor VSD is used to set Motor VSD data. Motor VSD password is required for check and modification.

Main function is below.

Menu	Preset Data	Function
VSD P (MPa)	00.70	Set AIR P in VSD mode to keep running stable. When pressure is fluctuated around this data, controller will adjust operating frequency of inverter to control the pressure close to this data(This data is only available in MOTOR VSD or MOTOR/FAN VSD mode)
MOTOR UP SPEED	1000	Restrict PID calculations in case the frequency increasing too fast which cause motor speeding up too fast
MOTOR DN SPEED	1000	Restrict PID calculations in case the frequency decreasing too fast which cause motor slowing down too fast
MOTOR RATED POWER (KW)	022.0	Set MOTOR RATED POWER in order to calculate actual power in VSD mode(This data is only available in MOTOR VSD or MOTOR/FAN VSD mode)
MOTOR RATED SPEED (RPM)	1500	Set MOTOR RATED SPEED at 50HZ in order to calculate the actual speed in VSD mode (This data is only available in MOTOR VSD or MOTOR/FAN VSD mode)
MOTOR INT INITIAL	0020	When detected $AIR P < (PID TARGET P - INTEGRAL SCALE)$ or Detected $AIR P > (PID TARGET P + INTEGRAL SCALE)$ Integral calculation is based on this data
MOTOR INT SCALE (Mpa)	00.20	$(PID TARGET P - INTEGRAL SCALE) < detected AIR P < (PID TARGET P + INTEGRAL SCALE)$,INTEGRAL GAIN works
MOTOR POWER COEF	0.800	Coefficient to calculate motor power
MOTOR PROP GAIN	0050	Track speed of PID TARGET P , the bigger the data, the faster the track; the smaller the data, the slower the track
MOTOR INT GAIN	0060	Track the speed of PID TARGET P and STEADY STATE ERROR, the bigger the data ,the faster the track and smaller the STEADY-STATE ERRORS; the smaller the data ,the slower the track and bigger the STEADY-STATE ERRORS
MOTOR DIFF GAIN	0000	Track the hysteresis system(such as temperature) ,it is not used very often and normally set as “0000”
MOTOR MAX FREQ (HZ)	180.0HZ	The maximum operating frequency in loading status
MOTOR MIN FREQ (HZ)	040.0HZ	In the process of adjustment, The minimum operating frequency when pressure is over the LOAD P pressure and not reach the UNLD P
MOTOR UNLD FREQ (HZ)	0035.0HZ	Permitted operating frequency in UNLD MODE

MOTOR INVERTER ADD	0001	Set the MOTOR VSD ADD and keep it consistent with VSD COM ADD
MOTOR PID CYCLE (S)	000.8S	Set the PID calculation interval time to adjust motor speed.
MOTOR INVERTER MODEL	ATV61	Controller can prestore at most 10 different inverter communication address (Inverter should support MODBUS RTU protocol for communication)
MOTOR STOP MODE	SLOW/FREE	<p>1、 INVERTER START MODE to COM ON-OFF: SLOW: When controller receives stop command, INLET VALVE terminals will open. Controller sends stop command to inverter to slow stop inverter FREE: When controller receives stop command, INLET VALVE terminals will open. Controller sends write frequency through RS485. Controller frequency will decrease and send stop command to inverter 1S before stop delay finished.</p> <p>2、 INVERTER START MODE to TERMINAL ON-OFF: SLOW: When compressor receives stop command, INLET VALVE terminals will open and MOTOR INVERTER RUN terminal will open. The compressor will stop according to STOP DELAY set. FREE: When compressor receives stop command, Inlet valve will open. MOTOR INVERTER RUN terminal will keep closed to control inverter frequency decreasing and it will open until 1 S before STOP DELAY finishes</p>
INVERTER START MODE	COM / TERMINAL	<p>COM ON-OFF : Start or stop inverter through RS485 TERMINAL ON-OFF: Start or stop inverter through digital input Note: 1, Controller set should be accordance with INVERTER START MODE 2, When controller is set to PF/VF mode, terminal 12 functions as inverter control terminal so only COM ON-OFF is available to control inverter</p>
INVERTER START NO.	0006	Maximum allowable time Controller sends start command to inverter with no response.
INVERTER STOP NO.	0006	Maximum allowable time Controller sends stop command to inverter with no response.
VSD MOTOR POWER CONSUMPTION Kw.H	0000000.0	Set the accumulative motor VSD running power consumption.
MOTOR INVERTER DELAY(S)	1.0	Press start button, motor sends start command to inverter after this set time.
CONSTANT POWER PRESSURE 1(MPa)	0.60	In constant power running mode, when pressure is above the data set here, Max output frequency is set as CONSTANT POWER FREQUENCY1

CONSTANT POWER PRESSURE 2(MPa)	0.70	In constant power running mode, when pressure is above the data set here, Max output frequency is set as CONSTANT POWER FREQUENCY2
CONSTANT POWER PRESSURE 3(MPa)	0.80	In constant power running mode, when pressure is above the data set here, Max output frequency is set as CONSTANT POWER FREQUENCY3
CONSTANT POWER PRESSURE 4(MPa)	0.90	In constant power running mode, when pressure is above the data set here, Max output frequency is set as CONSTANT POWER FREQUENCY4
CONSTANT POWER PRESSURE 5(MPa)	1.00	In constant power running mode, when pressure is above the data set here, Max output frequency is set as CONSTANT POWER FREQUENCY5
CONSTANT POWER PRESSURE 6(MPa)	1.10	In constant power running mode, when pressure is above the data set here, Max output frequency is set as CONSTANT POWER FREQUENCY6
CONSTANT POWER PRESSURE 7 (MPa)	1.20	In constant power running mode,when pressure is above the data set here, Max output frequency is set as CONSTANT POWER FREQUENCY7
CONSTANT POWER FREQUENCY 1(HZ)	180.0	See Note1:
CONSTANT POWER FREQUENCY 2(HZ)	160.0	
CONSTANT POWER FREQUENCY 3(HZ)	140.0	
CONSTANT POWER FREQUENCY 4(HZ)	120.0	
CONSTANT POWER FREQUENCY 5(HZ)	100.0	
CONSTANT POWER FREQUENCY 6(HZ)	80.0	
CONSTANT POWER FREQUENCY 7(HZ)	60.0	

Note 1: In constant power running mode

CONSTANT POWER PRESSURE 1<= CONSTANT POWER PRESSURE 2<= CONSTANT POWER PRESSURE 3<= CONSTANT POWER PRESSURE 4<= CONSTANT POWER PRESSURE 5<= CONSTANT POWER PRESSURE 6<= CONSTANT POWER PRESSURE 7

Note 2: CONSTANT POWER FREQUENCY 1>= CONSTANT POWER FREQUENCY 2>= CONSTANT POWER FREQUENCY 3>= CONSTANT POWER FREQUENCY 4>= CONSTANT POWER FREQUENCY 5>= CONSTANT POWER FREQUENCY 6>= CONSTANT POWER FREQUENCY 7

Note 3: Suppose M>N, When CONSTANT POWER PRESSURE N set to 00.00, CONSTANT POWER PRESSURE M and CONSTANT POWER FREQUENCY M, the set is invalid.

Note 4: When constant power function is not required,set CONSTANT POWER PRESSURE to 00.00MPa

1.17 Fan VSD

Fan VSD is used to set Fan VSD data. Fan VSD password is required for check and modification. Main

function is below.

Menu	Preset Data	Function
FAN VSD T (°C)	0078°C	In VSD mode, set DISC T to keep running stable. When DISC T is fluctuated around this data, controller will adjust operating frequency of fan inverter to control DISC T close to this data(This data is only available in FAN VSD or MOTOR/FAN VSD mode)
MAX VSD T (°C)	0085°C	When DISC T is above or equal to this data, control fan inverter output frequency to FAN MAX FREQ(This data is only available in FAN VSD or MOTOR/FAN VSD mode)
FAN UP SPEED	1000	Restrict PID calculations in case the frequency increasing too fast which cause fan speeding up too fast
FAN DN SPEED	1000	Restrict PID calculations in case the frequency decreasing too fast which cause fan slowing down too fast
FAN RATED POWER	001.5KW	Set FAN RATED POWER to calculate the actual fan power in FAN VSD mode(This data is only available in FAN VSD or MOTOR/FAN VSD mode)
FAN RATED SPEED	1500RPM	Set the corresponding fan speed in 50HZ to calculate actual fan speed in FAN VSD mode((This data is only available in FAN VSD or MOTOR/FAN VSD mode)
VSD FAN START T (°C)	0070°C	VSD fan will start if DISC T is above this set data(This data is only available in FAN VSD or MOTOR/FAN VSD mode)
VSD FAN STOP T (°C)	0065°C	VSD fan will stop if DISC T is below this set data(This data is only available in FAN VSD or MOTOR/FAN VSD mode)
FAN INT INITIAL	0020	When detected $DISC T < (PID TARGET T - INTEGRAL SCALE)$ or Detected $DISC T > (PID TARGET T + INTEGRAL SCALE)$ Integral calculation is based on this data
FAN INT SCALE (°C)	0005°C	$(PID TARGET T - INTEGRAL SCALE) < detected DISC T < (PID TARGET T + INTEGRAL SCALE)$,INTEGRAL GAIN works. Beyond this range, INT INITIAL works.
FAN PROP GAIN	0100	Track speed of PID TARGET T , the bigger the data, the faster the track and the less stable the data; the smaller the data the slower the track and the slower the adjustment
FAN INT GAIN	0020	Track the speed of PID TARGET T and steady state error, the bigger the data ,the faster the track and smaller the steady-state errors; the smaller the data ,the slower the track and bigger the steady-state errors
FAN DIFF GAIN	0000	Normally set as“0000”, this function is not activated
FAN MAX FREQ (HZ)	050.0HZ	In the process of adjustment, The maximum operating frequency when temperature is over the VSD work temperature
FAN MIN FREQ (HZ)	010.0HZ	In the process of adjustment, The minimum operating frequency when temperature is below the VSD work temperature

VSD FAN POWER COEF	0.900	Coefficient to calculate VSD fan power
FAN INVERTER ADD	2	Set the FAN VSD ADD and keep it consistent with VSD COM ADD
FAN PID CYCLE (S)	001.5S	Set the PID calculation interval time to adjust fan speed.
FAN INVERTER MODEL	ATV31	Choose inverter protocol
FAN INVERTER START MODE	COM/ TERMIN AL	Set fan inverter start mode
VSD FAN ELEC (Kw.H)	000000.00	VSD fan power consumption

1.18 Date

Check and set time

1.19 Operation Authorization and Password

Controller provides multiple passwords and access management. According to different levels of passwords, controller provides different levels of operating authorization, details as following:

1.19.1 CUSTOMER PASSWORD: factory set:

Permissions: Allows to modify all CUSTOMER PRAMETER.

1.19.2 FACTORY PASSWORD: fixed:

Permissions: Allows to modify all CUSTOMER PRAMETER.

Permissions: Allows to modify BASIC PARAMETER, MOTOR VSD PARAMETER, FAN VSD PARAMETER in FACTORY PARAMETER

1.19.3 CALIBRATE PASSWORD: fixed:

Permissions: Allows to modify all CALIBRATE PARAMETER

1.19.4 BLOCK PASSWORD:

Permissions: Allows to modify all BLOCK PARAMETER

1.19.5 HARDWARE CONFIG PASSWORD: fixed:

Permissions: Allows to modify all HARDWARE CONFIG

1.19.6 MAINTENANCE PARAMETER PASSWORD

Permissions: Allows to modify all MAINTENANCE PARAMETER.

1.19.7 INVERTER SET PASSWORD:

Permissions: Allows to modify all INVERTER SET

1.19.8 TOUCH CALIBRATION PASSWORD

Permissions: Allows to modify TOUCH ACCURACY

1.19.9 SCHEDULED P PASSWORD

Permissions: Allows to modify all SCHEDULED P PARAMETER.

1.19.10 SCHEDULED ON/OFF PASSWORD

Permissions: Allows to modify all SCHEDULED ON-OFF PARAMETER

1.19.11 MOTOR VSD PASSWORD: fixed:

Permissions: Allows to modify all MOTOR VSD PARAMETER

1.19.12 FAN VSD PASSWORD: fixed:

Permissions: Allows to modify all FAN VSD PARAMETER

2,Controller Function and Technical Parameter

2.1 Ambient temperature: $-20^{\circ}\text{C} \sim +60^{\circ}\text{C}$; Humidity: $\leq 98\%$;

2.2 Digital input& output: 8 points of digital input (function optional) , 10 points of digital relay output

2.3 Analog input& output: 3 points of Pt100 temperature input. 2 point 4-20mA pressure input,2 groups of three phases current input (CT provided)

2.4 Input voltage of phases: 380V/ 220V.

2.5 High voltage, low voltage protection.

2.6 Controller operation power supply: AC16-28V、20VA

2.7 Measurement :

2.7.1 DISC T: $-50 \sim 350^{\circ}\text{C}$, Accuracy: $\pm 1^{\circ}\text{C}$.

2.7.2 Running time: 0~999999H.

2.7.3 Current: 0~999.9A.

2.7.4 Pressure: 0~1.60MPa. Accuracy; 0.01Mpa.

2.8 Phase anti-reversal protection: When compressor is at stop mode and detects phase reversal, response time $\leq 1\text{s}$

2.9 Motor protection: This controller provides open phase, unbalance and overload protection to motor, and also, provides overload protection to fan.

2.9.1, Open phase protection: When any phase opens, the response time equals to set time; This function is not activated when OPEN PHASE PROTECTION time is set over 20s

2.9.2, Unbalance protection: when MAX-MIN current $\geq \text{SET DATA} * \text{MIN current}/10$,respond time is 5s;

2.9.3, Protection features of overload (time unit: second), please see following table (table 2.9.3.1) for your reference. Multiple= $I_{\text{actual}} / I_{\text{set}}$, response time is shown in following table (table 2.9.3.1) according to overload multiples from 1.2 times and 3.0 times .

$I_{\text{actual}}/I_{\text{set}}$ Time parameter	≥ 1.2	≥ 1.3	≥ 1.5	≥ 1.6	≥ 2.0	≥ 3.0
Response time (S)	60	48	24	8	5	1

Table 2.9.3.1 curve table for protection of motor

2.10 Temperature protection: when actual temperature measured is higher than temperature set; response

time≤2s;

2.11 Contact capacity of output relay: 250V,5A; Contact endurance :500000 times

2.12 Current error is less than 1.0% .;

2.122 points of RS485communication port. 1 point is for block mode or computer communication.

The other point is for inverter communication like reading inverter run parameter, controlling inverter on-off or adjusting inverter frequency.

2.14 Remote control compressor: When set as REMOTE, user can remotely control the compressor.

3,Model and Specifixation

3.1 Model explanation

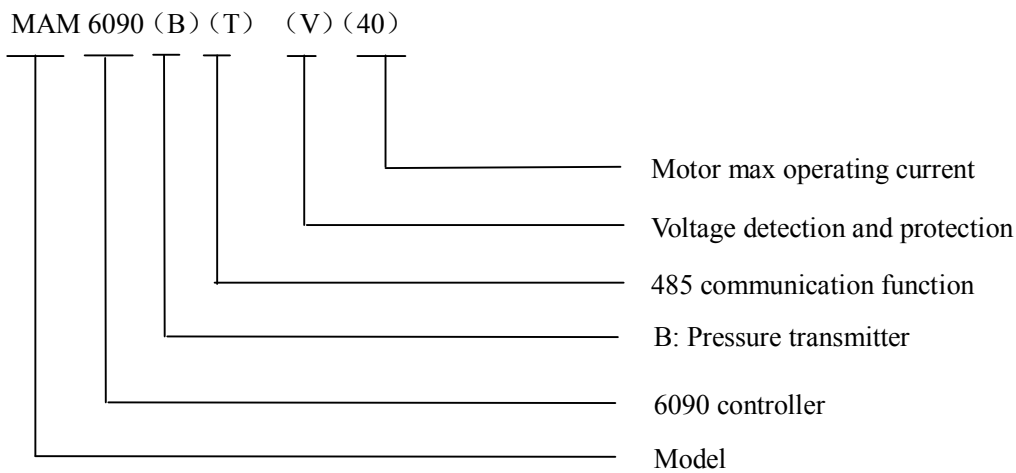

3.2 Power specification sheet for corresponding motor.

Specification	Current range (A)	Corresponding main motor power (KW)	Remark	Description
MAM6090 (20)	8~20	Below 11		Fan has three levels of current, such as 0.2-2.5A, 1-5A and 4-10A, determined-by current of motor
MAM6090 (40)	16~40	11-18.5		
MAM6090 (100)	100	22-45		
MAM6090 (200)	200	55-90		
MAM6090 (400)	400	110		
MAM6090 (600/5)	600/5	200-250	With CT	

Table 3.2.1 Power specification sheet for corresponding motor

4,Installation

4.1 Mechanical Installation

The CT shall be installed at a place where the current of motor cable can be measured, thus, controller can be set according to instructions on motor nameplate, and the detailed dimension is shown as below:

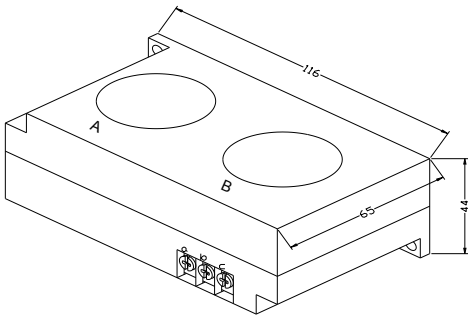

Picture 4.1.1, Structural dimension of CT1 (φ36hole)

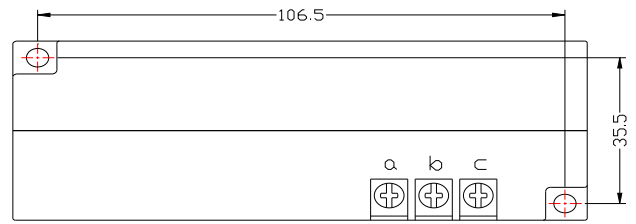

Picture 4.1.2, Installation dimension of CT1

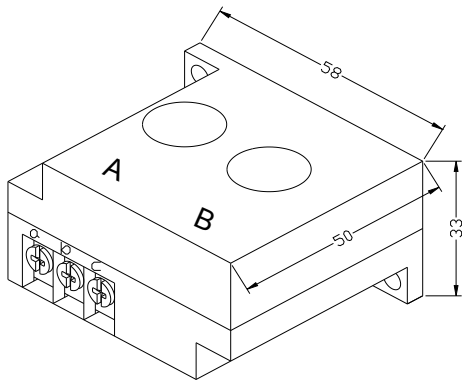

Picture 4.1.3, Structural dimension of CT2 (φ10hole)

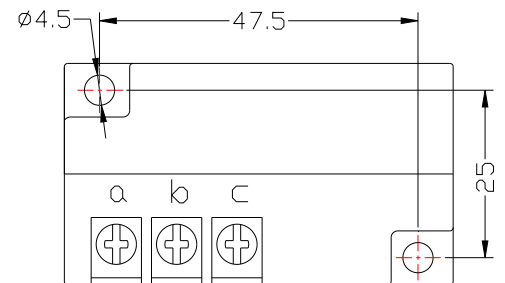

Picture 4. 1.4, Installation dimension of CT2

4.2 Controller Installation

When install the controller, room should be left around controller for wiring. The specific dimension is shown as below:

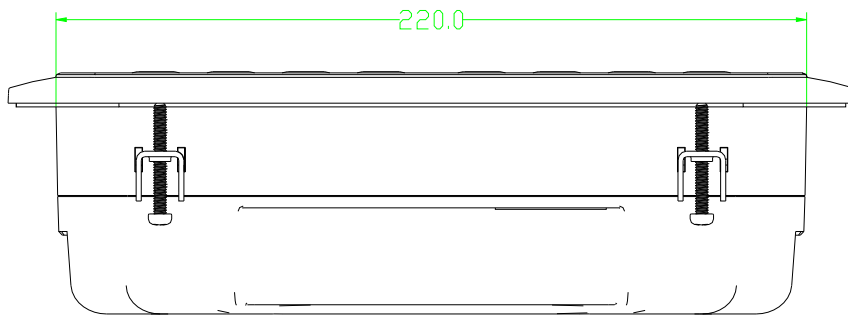
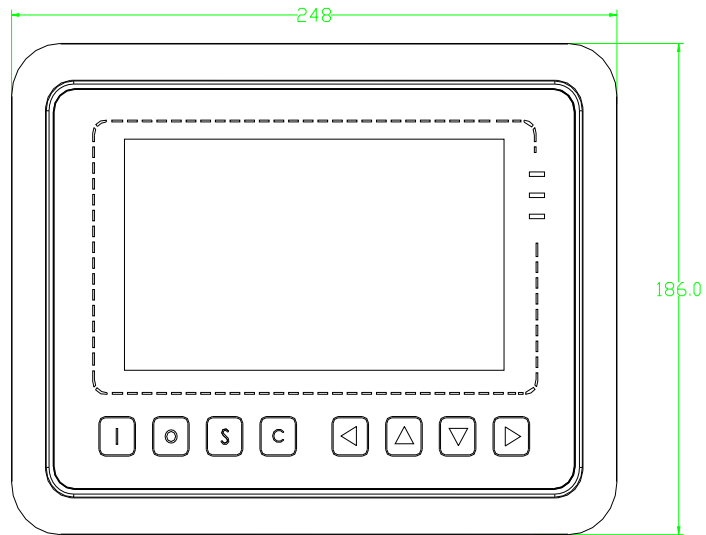
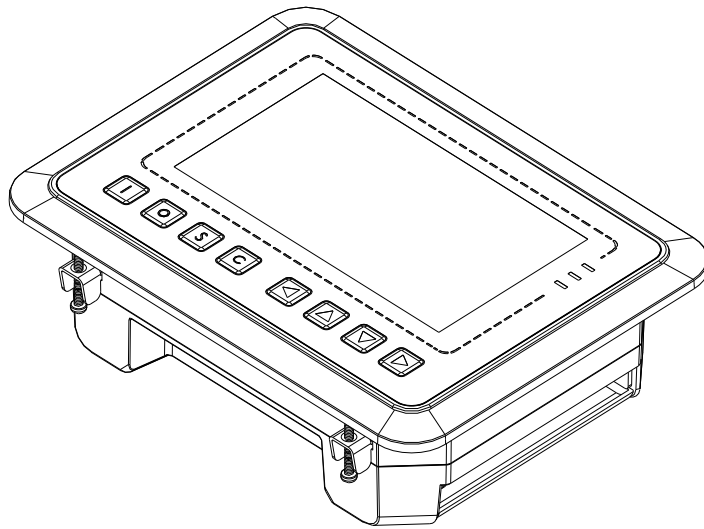

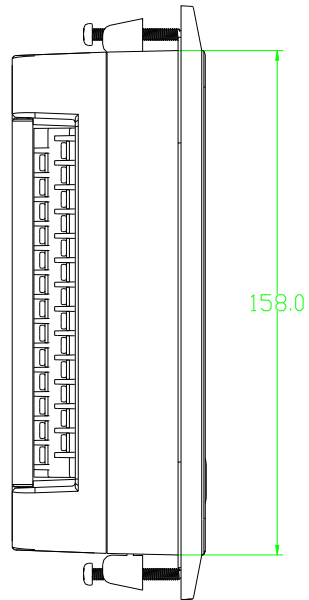
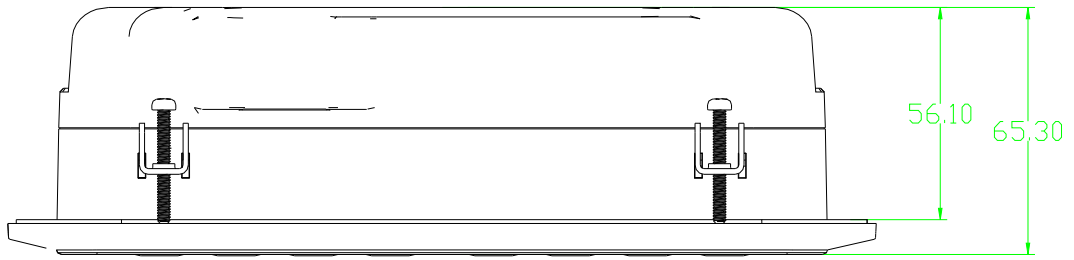

4.2.1 Controller structure dimension

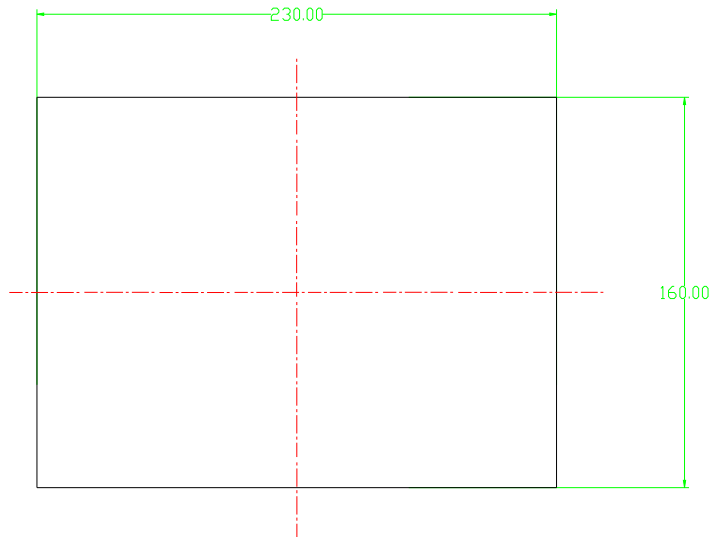

Picture 4.2.3 Hole size

Note: Though rear cabinet is 220mm, the hole size should be at least 230mm. After connect the cable in the rear cabinet, there will be about 10-15mm more space requested. You can save the step of dispatch cable when install controller.

5,Alarm function

5.1,Air Filter Alarm

- ①. Air filter block check. (In HARDWARE CONFIG , there is air check function set in digital input terminal)
The monitor displays AIR BLOCK by checking pressure differential switch close.
- ②. Air filter running time alarm
The text displays AIR TIME END when running time of the air filter is exhausted.

5.2,Oil Filter Alarm

- ①. Oil filter block check. (In HARDWARE CONFIG, there is oil check function set in digital input terminal)
The monitor displays OIL BLOCK by checking pressure differential switch close.
- ②. Oil filter running time alarm
The text displays OILTIME END when running time of the oil filter is exhausted.

5.3,O/A Separator Alarm

- ①. O/A separator block check. (In HARDWARE CONFIG, there is O/A check function set in digital input terminal)

The monitor displays O/A BLOCK by checking pressure differential switch close.

- ②. O/A filter running time alarm

The text displays O/A TIME END when running time of the oil filter is exhausted.

5.4,Lubricant Alarm

The text displays LUBE TIME END when running time of the lubricant is exhausted.

5.5,Grease Alarm

The text displays GREASE TIME END when running time of the grease is exhausted.

5.6, Stage 2 Temperature High Alarm

The text displays STAGE 2 T HIGH when DISC T is higher than STAGE 2 ALARM T set in FACTORY PARAMETER.

6,Controller Protection

6.1 Motor Protection

MAM6090 compressor controller provides overload, open phase, unbalance, high voltage, low voltage protection to motor and overload protection to fan.

Electronic failure	Failure Display	Reason
Overload	Display “:MOTOR/FAN CURR OVLD”	Overload, bearing wear and other mechanical failure
Open phase	Display “MOTOR CUR OPEN PHASE”	Power supply, contactor and open phase of motor
Current Unbalance	Display “MOTOR CURR UNBAL”	Poor contact of contactor, inside open loop of motor
High Voltage	Display “HIGH VOLTAGE”	Motor voltage high
Low Voltage	Display “LOW VOLTAGE”	Motor voltage low

6.2,Protection of Discharge Temperature High

When DISC T is above the STOP DISC T, the controller will alarm and stop the machine. THIS FAULT displays DISC T HIGH

6.3,Protection of Air Compressor Anti-reversal

When compressor is at stop status and three phases sequence is not in order, THIS FAULT displays PHASE WRONG1, and the controller cannot start the motor. Change the position of any arbitrary two phase power lines and check the rotation of motor.

6.4, Protection of Air compressor Open Phase

When compressor is at stop status and open phase is detected, THIS FAULT displays PHASE WRONG2, and the controller cannot start the compressor. Check the three phase.

6.5, Protection of Stage 2 P High

When the Stage 2 P is above the MAX LIM P, the controller will alarm and stop the machine. THIS FAULT displays STAGE 2 P HIGH.

6.6, Protection of Sensor Fault

When pressure sensor or temperature sensor is disconnected, the controller will alarm and stop the machine. THIS FAULT displays **SENSOR FAULT.

7, Trouble Shooting

Failure	Reason	Solution
High discharge temperature	Bad vent condition, Oil shortage etc.	Check the vent condition and lubricant amount etc.
Temperature Sensor Failure	Cable broken or PT100 failure	Check the wiring and PT100
High Pressure	Pressure too high or the pressure sensor failure	Check the pressure and the pressure sensor
Pressure Sensor Failure	Cable broken, Sensor failure or the cables connect reversely	Check the wiring and pressure transmitter
Open Phase	Power open phase or the contactor failure	Check the power and contactors
Overload	Voltage too low, tubes block, bearing wear off or other mechanical failure or wrong set data etc.	Check the set data, voltage, bearings, tubes and other mechanical system.
Unbalance	Current unbalance, contactor failure or the internal open loop of the motor	Check the power, contactor and the motor
Wrong Phase Sequence	Phase sequence reversal or open phase	Check the wiring
Motor overload during start	Master start time set to less than the star delta delay time	Reset the master start time longer than star delay + 2 seconds
Main Contactor shakes frequently	The emergency stop button is loose or controller is reset by	Check if the coil of contactor connects with RC snubber or not

	interference	
Inverter communication fault	Wrong set of relatively parameter of controller and inverter; Communication cable loose	Check the set data ;Check the cable

8, Block Control and Network Communication

8.1 Block Control:

MAM6090 controller can work in block mode with MAM series compressor (with communication function).16 pieces compressors can work together in a net at most. Block mode can be set as VSD –VSD,PF-PF or VSD- PF .The cable connection for block mode control is as below....1,2 terminals (RS485 terminal) are used for block mode.

In BLOCK PARAMETER SET menu, set as VSD-VSD or PF-PF, master chooses compressor to work according to the TOTAL RUN TIME. Compressor with shorter running time is chosen to start and compressor with longer running time is chosen to stop with priority.

In BLOCK PARAMETER SET menu,, set as VSD-PF, master works first, other compressors work according to the TOTAL RUN TIME. Compressor with shorter running time is chosen to start and compressor with longer running time is chosen to stop with priority.

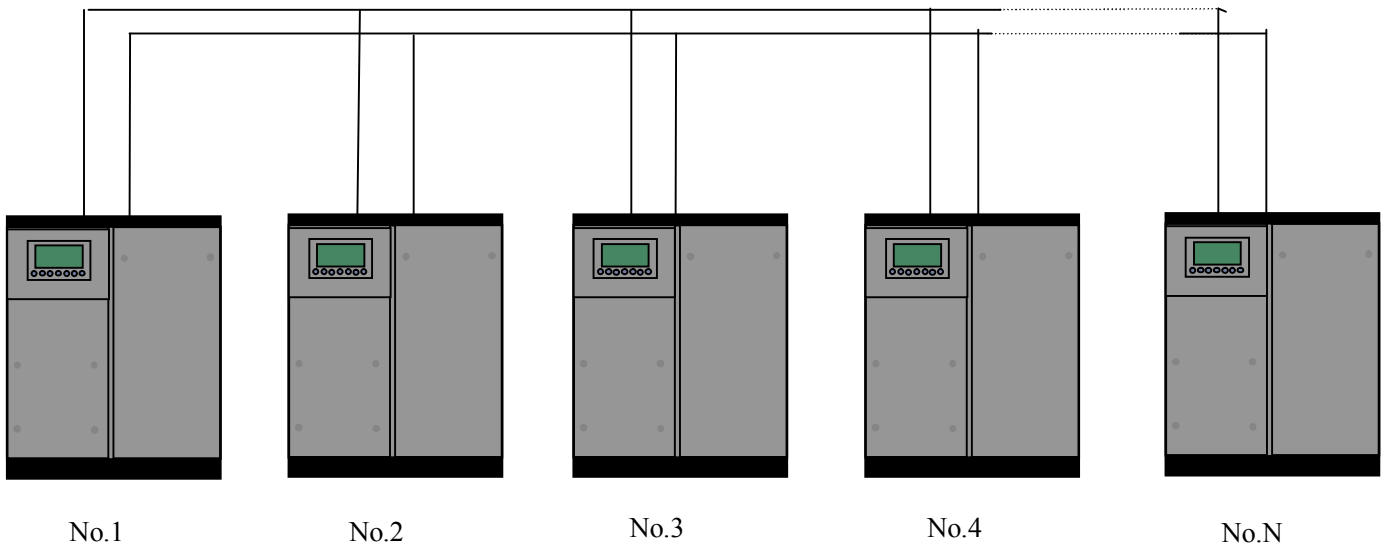

Picture8.1.1.1

Compressor with COM ADD 0001 is master, others are slave. Any one MAM series compressor can be set as master or slave.

8.1.1 Block Control Set:

8.1.2.1 Set as Master:

Set the COM ADD in USER PARAMTER to 001

According to user requirement, set COM MODE, BLOCK NUMBER, TURN TIME, BLOCK LOAD P, BLOCK UNLD P, BLOCK DELAY , BLOCK MODE .After set, controller needs to be powered off and restart to save setting.

8.1.2.2 Set as Slave:

When MAM6090 controller serves as slave, it is only necessary to set COM MODE as BLOCK, COM ADD can be set from 2-16 in sequence according to the quantity of compressors, .BLOCK STATUS set as SLAVE.

8.1.2 Start, Stop Block mode:

Make sure block cables connect correctly, also the parameter of compressor in block mode is set correctly. Activate master, master controls the compressor in net automatically according to the AIR P detected. When manually stop the master, block control stops at the same time, thus, master will no longer send command to compressors in net.

8.2 Network Communication

MAM6090 controller supports MODBUS RTU protocol and can serve as slave when connects with other equipment .It is supports 03、 06、 16 MODBUS command. Communication baud rate: 9600BPS, 1 start bit, 8 data bits, 1 stop bits and even parity. For MODBUS register address, please see MODBUS communication manual.

9, Inverter Control

485 communication control

There is one spare port for RS485 to communicate with inverter. User can start or stop controller through RS485,it transfers the output frequency based on PID calculation to inverter through 485 port. This is how to adjust inverter output frequency and realize constant pressure and temperature. The baud rate is fixed as 9600BPS when RS485 control inverter. Different inverter data format can be set in INVERTER SET in FACTORY PARAMETER. MOTOR INVERTER is suggested to be set as 0001, FAN INVERTER is suggested to be set as 0002.

In order to be compatible with different inverter, set the item such as CURR(R) ADD, VOLT(R) ADD, FREQ(R) ADD , POWE(R) ADD, RUN (W) ADD, ERR STATE(R) ADD, FREQ(W) , RESET(W) ADD. For different inverter, amplification of current, voltage, frequency, power is different. Write a formula to every parameter to transfer current, voltage, frequency, power of inverter to one digit data.

Relative parameter introduction is as below, please take the Schneider 67,71 inverter as example.

Item	Data Set	Explanation
INVERTER NAME:	0ATV61	Set inverter name
RUN(W) ADD1:	2135	Corresponding address 1 of inverter start command
RUN VALUE:	0001	This data is inverter start data (please refer to communication chapter in inverter manual for different inverter.)
RUN(W) ADD2:	2135	Corresponding address 2 of inverter start command

RUN VALUE:	0001	This data is inverter start data (please refer to communication chapter in inverter manual for different inverter.)
STOP(W) ADD:	2135	Corresponding address of inverter stop command
RUN VALUE:	0001	This data is inverter start data (please refer to communication chapter in inverter manual for different inverter.)
RESET(W) ADD:	2135	Corresponding address of inverter reset command
RUN VALUE:	0001	This data is inverter start data (please refer to communication chapter in inverter manual for different inverter.)
FREQ(W) ADD:	2136	Corresponding register address of inverter running frequency source
FREQ(R) =	$REC * 0001 \div 0001$	The REC value is frequency value with one decimal. Use formula to transfer to corresponding value based on different inverter and send it to inverter. Example: 50HZ running frequency, REC value:500 For inverter with write frequency of 2 decimals, formula: $REC ** 0001 \div 0010$ For inverter with write frequency of 1 decimal, formula: $REC ** 0001 \div 0001$ For the inverter whose max output frequency is in corresponding with 10000,the formula : $REC * 0020 \div 0001$
STATE(R) ADD:	2135	Read inverter running status address
RUN S =	R AND $0001 = 0001$	Check if inverter has run the formula(please refer to communication chapter in inverter manual)
COM FORM	8N1-N	Set the data format of controller and inverter communication. This set should be consistent with inverter communication format 8N1-N: 1start bit,8 data bits,1 stop bit, no parity bit 8N1-E: 1start bit,8 data bits,1 stop bit, even parity bit 8N1-O: 1start bit,8 data bits,1 stop bit, odd parity bit 8N2-N: 1start bit,8 data bits,2 stop bit, no parity bit Note: Communicate with inverter, the baud rate is fixed:9600
FREQ(R) ADD	0C82	Read inverter frequency address(refer to inverter manual)
FREQ(R) =	$REC * 0001 \div 0001$	Calculate inverter frequency formula. Controller will transfer the frequency to one decimal.
VOLT(R) ADD	0C88	Read inverter voltage address
VOLT(R) =	$REC * 0001 \div 0001$	Calculate inverter voltage formula. Controller will transfer the voltage to one decimal
CURR(R) ADD	0C84	Read inverter current address
CURR(R) =	$REC * 0001 \div 0001$	Calculate inverter current formula. Controller will transfer the current to one decimal

POWE(R) ADD	0C8B	Read inverter power address
ERR S =	R AND 0000≠0000	Inverter reports error formula or not
EMERGENCY ADD	2135	Corresponding add of inverter emergency stop command
RUN VALUE	0001	This data is inverter free stop data (please refer to communication chapter in inverter manual for different inverter.)

Firstly, controller sends 0 to corresponding register of“STATE(R) ADD” through inverter. After delay for a while, sends 1 to corresponding register of“RUN1(W) ADD”. After another delay, reads“ RUN S”register, and judges if the inverter is running based on the set formula. Calculate the output frequency based on the comparison of pressure detected and pressure set and send this value to corresponding address of“FREQ(R) ADD” through formula operation.

Schneidel inverter parameter set:

1、CON |AD2-

|AD1-|ADD :1

|EBr :96

|EFO :8N1

|EEO :15

CTL- |Fr1 :ndb

|rln

|PST

|CHCF :IO

|CD1 : ndb

Flt- |PTC-

|rST- |rSF :C107

10, Schematic Diagram

10.1PF

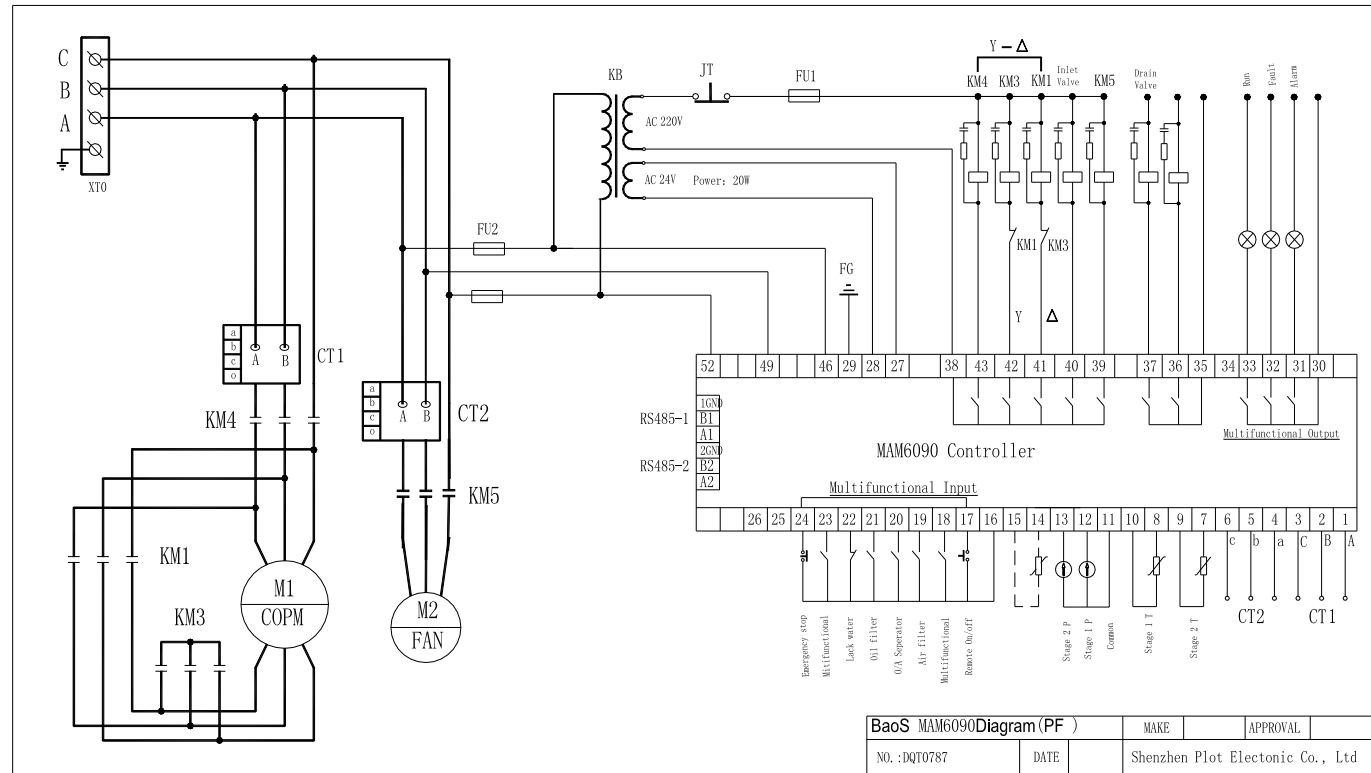

10.2PF /VSD

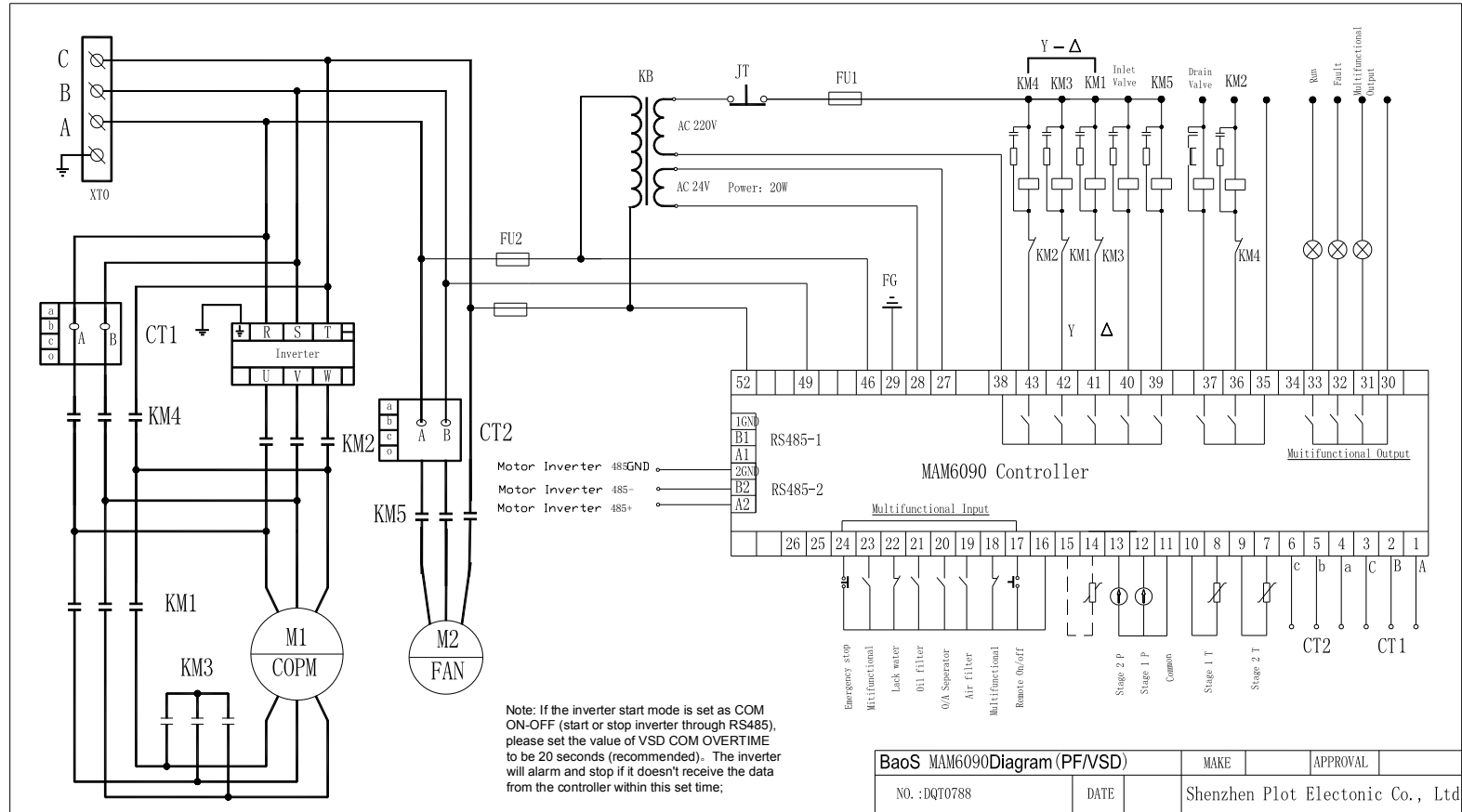

10.3 FAN VSD

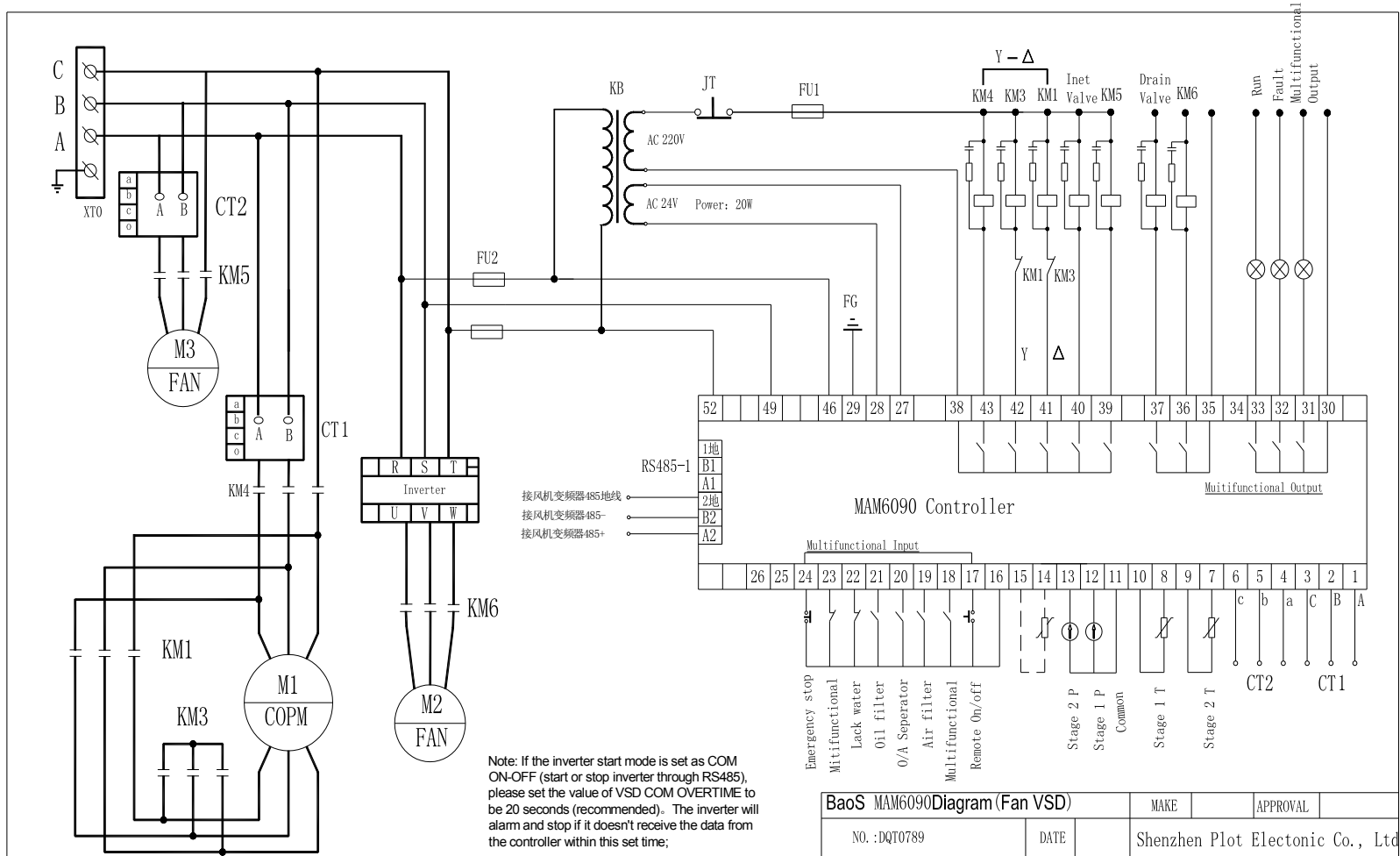

10.4MOTOR /FAN VSD

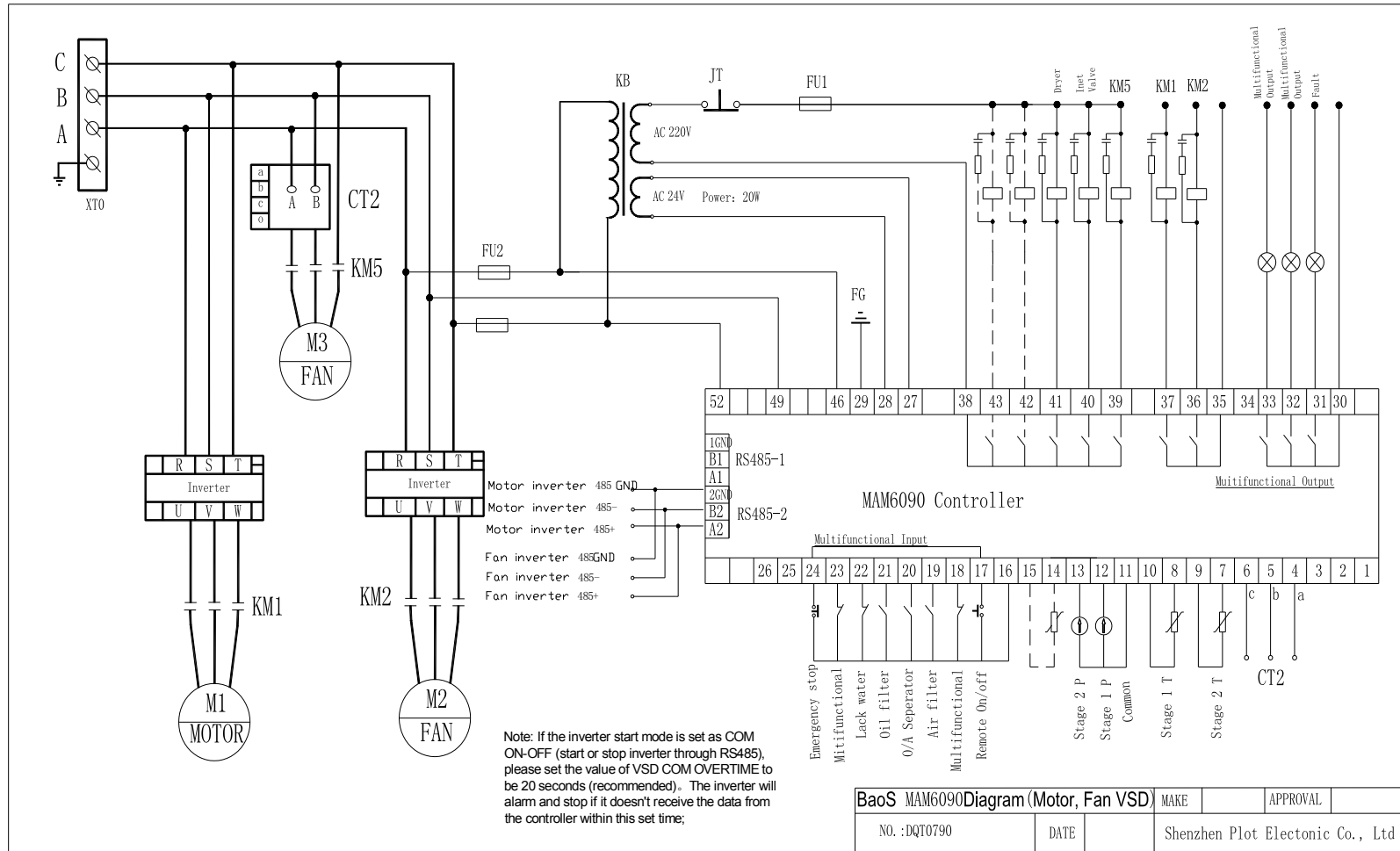

10.5SOFT START

